



Specification for

Class II oxy-acetylene welding of carbon steel pipework for carrying fluids

ICS 25.160.10

Committees responsible for this British Standard

The Welding Standards Committee, under whose direction this British Standard was prepared, consists of representatives from the following:

Aluminium Federation
 Associated Metal Workers Union
 Associated Offices Technical Committee*
 British Compressed Gases Association
 British Constructional Steelwork Association
 British Railways Board
 British Shipbuilders
 British Steel Industry*
 Crown Agents for Oversea Governments and Administrations
 Health and Safety Executive*
 Institution of Civil Engineers
 Institution of Electrical Engineers
 Institution of Production Engineers
 Institution of Structural Engineers
 Lloyd's Register of Shipping
 Ministry of Defence
 Process Plant Association
 Society of British Aerospace Companies Limited
 Society of Motor Manufacturers and Traders Limited
 Water-tube Boilermakers' Association*
 Welding Institute*
 Welding Manufacturers Association*

The organizations marked with an asterisk in the above list, together with the following, were directly represented on the Technical Committee entrusted with the preparation of this British Standard:

British Gas Corporation
 British Non-ferrous Metals Federation
 Electricity Supply Industry in England and Wales
 Engineering Equipment Users Association
 Heating and Ventilating Contractors' Association
 Institute of Plumbing
 Institution of Gas Engineers
 Institution of Mechanical Engineers
 Joint Industry Board for Plumbing Mechanical Engineering Services in England and Wales
 Oil Companies Materials Association
 Power Generation Association
 Stainless Steel Fabricators Association of Great Britain
 United Kingdom Atomic Energy Authority
 Individual firms

This British Standard, having been prepared under the direction of the Welding Standards Committee, was published under the authority of the Board of BSI and comes into effect on 26 February 1982

© BSI 05-1999

First published September 1955
 First revision February 1982

ISBN 0 580 12507 6

Amendments issued since publication

Amd. No.	Date of issue	Comments
4503	March 1984	
5166	July 1986	
9749	February 1998	Indicated by a sideline in the margin

Contents

	Page
Committees responsible	Inside front cover
Foreword	iii
<hr/>	
Section 1. General	
1 Scope	1
2 References	1
3 Parent metals	1
4 Filler rods	1
5 Equipment	1
6 Welding technique	1
7 Proximity of welds	1
8 Fusion faces	1
9 Assembly for welding	2
10 Cold pull	2
11 Heat treatment	2
12 Inspection	2
<hr/>	
Section 2. Butt joints	
13 General	2
14 All types of butt joint	2
15 Gusseted bends	4
<hr/>	
Section 3. Branches	
16 General	6
17 All types of branches	6
18 Set-on branches	8
19 Set-in branches	8
20 Extruded branches	11
21 Forged fittings	11
<hr/>	
Section 4. Sleeve joints and socket-welding fittings	
22 General	11
23 Sleeve joint details	11
24 Socket joint details	12
<hr/>	
Section 5. Structural attachments	
25 General	13
26 Welding procedure	13
<hr/>	
Section 6. Flanges	
27 General	13
28 Welding neck flanges	13
29 Welded-on flanges	14
<hr/>	
Section 7. Inspection requirements	
30 Requirements for visual examination of completed welds	14
31 Testing of completed welds	15
32 Non-destructive testing of butt joints	15
<hr/>	
Section 8. Rectification of faulty welds	
33 Removal of faults	16
34 Preparation for re-welding	16
35 Re-welding	17
<hr/>	
Section 9. Welding procedure approval	
36 General	17
37 Attachments to thin pipes	18

	Page
Section 10. Welder approval	
38 General	18
39 Branch connections and flange attachments	18
40 Attachments to thin pipes	18
<hr/>	
Appendix A Classes of operating conditions	19
Appendix B Items for agreement between the contracting parties	19
Appendix C Welding techniques	19
<hr/>	
Figure 1 — Thick to thin sections	4
Figure 2 — Segmental bends	5
Figure 3 — Cut-and-shut bend	6
Figure 4 — Curved or “easy sweep” branch joint	7
Figure 5 — Minimum height of flanged branches	7
Figure 6 — Details of set-on branches	9
Figure 7 — Details of set-in branches	10
Figure 8 — Extruded branch	11
Figure 9 — Forged fittings for branch joints	11
Figure 10 — Sleeve joints	12
Figure 11 — Fillet welds for sleeve joints	12
Figure 12 — Socket joint	13
Figure 13 — Welding neck flange	14
Figure 14 — “Slip on” hubbed welded-on flange	14
Figure 15 — Partial cut-out in rectification of faulty welds	16
Figure 16 — Rightward (or backward) technique	20
Figure 17 — Blowpipe and rod angles for all-position rightward technique	21
Figure 18 — Leftward technique	21
Figure 19 — Multi-layer technique. Pipe horizontal	22
Figure 20 — Block-welding technique	22
<hr/>	
Table 1 — Sizing and alignment	3
Table 2 — Drifting of pipe ends	3
Table 3 — Preparation of ends	4
<hr/>	

Foreword

This revision of this British Standard has been prepared under the direction of the Welding Standards Committee. It embodies the technical developments that have taken place since the standard was first published in 1955. BS 2640:1955 is now withdrawn. On common aspects the standard has generally been aligned with BS 1821 and BS 2971.

Although for carbon steels with not more than 0.25 % carbon either this standard or BS 1821 may be used according to whether class II or class I welding is required, it is recommended that carbon steels with a carbon content exceeding 0.25 % and all alloy steels be welded in accordance with the requirements of BS 1821 irrespective of the operating conditions. Because of its increased use for quality control purposes, non-destructive testing has been introduced as an optional requirement together with the allied acceptance levels. These levels are based upon experience of what can be achieved commercially on class II work. While no scientific basis is implied, it is known that such levels represent welds in pipework that have given satisfactory service life and therefore of a quality that may be regarded as class II.

The relevant application standard, where it exists, should specify whether class II welding of pipework is required, but the factors to be taken into account in coming to such a conclusion are the operating conditions of the pipework, the degree of inspection and the acceptance requirements. (See also Appendix A.)

The following are companion standards to this standard:

BS 1821, *Class I oxy-acetylene welding of ferritic steel pipework for carrying fluids.*

BS 2633, *Class I arc welding of ferritic steel pipework for carrying fluids.*

BS 2971, *Class II arc welding of carbon steel pipework for carrying fluids.*

BS 4204, *General requirements for the flash welding of steel pipes and tubes for pressure and other high duty applications.*

BS 4677, *Class I arc welding of austenitic stainless steel pipework for carrying fluids.*

Inspecting authority. The term “inspecting authority” refers to that competent independent body or association which verifies compliance with this standard.

Pipe dimensions. Unless otherwise qualified, for the purposes of this British Standard “pipe diameter” relates to the specified value of the outside diameter and “pipe thickness” relates to the specified value of the wall thickness of the pipe in the as supplied condition.

It has been assumed in the drafting of this standard that the execution of its provisions is entrusted to appropriately qualified and experienced people.

A British Standard does not purport to include all the necessary provisions of a contract. Users of British Standards are responsible for their correct application.

Compliance with a British Standard does not of itself confer immunity from legal obligations.

Summary of pages

This document comprises a front cover, an inside front cover, pages i to iv, pages 1 to 22, an inside back cover and a back cover.

This standard has been updated (see copyright date) and may have had amendments incorporated. This will be indicated in the amendment table on the inside front cover.

Section 1. General

1 Scope

This British Standard specifies requirements for both shop and site class II oxy-acetylene welding of joints in carbon steel pipework of a thickness not exceeding 10 mm intended to carry fluids.

Attention is particularly drawn to Appendix B which lists items for agreement between the contracting parties.

2 References

The titles of the standards publications referred to in this standard are listed on the inside back cover.

3 Parent metals

This standard relates to pipes and attachments made from carbon steel containing not more than 0.25 % carbon that comply with the requirements of:

BS 1387

BS 3059-1-320

BS 3059-2-360 and 3059-2-440

BS 3601-320, 3601-360 and 3601-410

BS 3602-1-360, 3602-1-410 and 3602-1-460

BS 3602-2-410 and 3602-2-460

BS 3606-320 and 3606-440

The use of equivalent alternative steels to those complying with the above standards is permitted. The material used for pipes and fittings shall be fully suitable for the service conditions.

While the requirements and limitations of this standard apply also to the welding of cast parts, additional precautions in inspection and welding procedure that may be necessary to deal with the presence of non-metallic inclusions or porosity, shall be subject to agreement between the purchaser and the manufacturer.

4 Filler rods

Filler rods of type A2 or A3 complying with the requirements of BS 1453 shall be used.

5 Equipment

All welding equipment shall be in good condition and such as to enable the welder to maintain the correct neutral flame at all times.

Where necessary, staging and protection from the weather shall be provided to enable the welding operation to be performed properly.

6 Welding technique

Welding shall be carried out by any of the techniques described in Appendix C subject to the limits imposed in Table 3.

7 Proximity of welds

The design of joints shall be such as to provide adequate access for the deposition of weld metal to meet the requirements of this standard.

Joints where more than two welded seams meet should be avoided. If the design cannot avoid this, then appropriate precautions shall be taken which shall be agreed between the manufacturer, the purchaser and the inspecting authority.

8 Fusion faces

The fusion faces and the adjacent material shall be free from moisture, scale, rust, paint, grease or other foreign matter immediately prior to welding.

Certain proprietary protective coatings are specially formulated with the intention that they should not interfere with subsequent welding. The use of such coatings is not excluded by the requirements of this clause, but if so required by the purchaser the manufacturer shall demonstrate by means of specimen welds that the coating does not affect the quality of the weld.

9 Assembly for welding

To maintain the specified alignment and gap during welding (see Table 1 and Table 3) the pipes to be welded shall be securely held in position by mechanical means, welded-on bridge pieces or tack welding. If tack welding is adopted, the tack welds shall be either melted out during welding or made as part of the main weld and of the same quality as that weld.

It is appreciated that there may be difficulty in complying strictly with the specified requirements for the root gap. Slight modifications imposed by practical considerations shall be subject to agreement between the purchaser and the manufacturer.

10 Cold pull

Where the effects of thermal expansion in service are to be counteracted by "cold pull" during erection of the pipe assembly, the "cold pull" shall be maintained during welding, post-weld heat treatment (if any) and cooling.

Before applying "cold-pull" to a joint, all other joints in the pipe assembly shall have been welded, subjected to any post-weld heat treatment, inspected and accepted.

11 Heat treatment

It is advisable for the purchaser in all cases to inform the manufacturer of the use to which the pipework will be put. Normalizing or other post-weld heat treatment is not required for welded joints in pipework covered by this standard, unless the purchaser states in the enquiry and order that welds are to be heat treated in which case all details relating to such heat treatment shall be agreed between the contracting parties.

12 Inspection

The purchaser or his representative shall have access at all reasonable times to those parts of the works or site engaged on the preparation, fabrication and testing of the pipe assemblies which he has ordered.

Section 2. Butt joints¹⁾

13 General

Section 1 of this standard details the basic procedure requirements with which all welded joints between pipes and fittings shall comply. These basic requirements are supplemented by the specific requirements detailed in this section 2. Both section 1 and section 2 of this standard shall be applied in determining the full procedure requirements.

14 All types of butt joint

14.1 Matching of ends. The bores of the ends of adjacent pipes shall preferably, for welding purposes, match exactly, but in any case shall not differ at any diameter by more than the amounts specified in Table 1, whilst the alignment shall be within the limits specified in that table.

NOTE 1 The difference in thickness that can be tolerated between adjacent pipes for oxy-acetylene welding decreases with increasing pipe thickness.

NOTE 2 It is recognized that the ends of pipes and welding fittings will be supplied to standard tolerances and may not match, especially if placed together at random. Additional workmanship may therefore be required to ensure the alignment specified in Table 1.

¹⁾ In this section the term "pipe" is intended to cover pipes and fittings, (e.g. welding neck flanges, forged tees, welding elbows).

The welding of pipe joints in accordance with this standard shall include the proper sizing or matching by the welding contractor of the pipe ends at each joint, if necessary, before welding. (See also Figure 1(a).) Matching shall be effected by selection, drifting, machining or by the use of a suitable expander. If drifting is employed, a slow taper drift shall be used under the conditions specified in Table 2.

When drifting or expanding hot, the pipes shall be heated to a temperature either within the range 900 °C to 975 °C or within the range 500 °C to 620 °C.

Wherever the thickness is reduced by drifting, machining or expanding, the thickness at every point in the circumference clear of the weld preparation shall be not less than the design thickness for the particular pipe. Any machining shall run out smoothly at a taper not steeper than 1 in 4 [see Figure 1(b) and Figure 1(c)].

NOTE 3 If the maximum permissible amount of machining is insufficient to match the ends, drifting should be employed, but a combination of drifting or expanding, with machining within the permitted limits, may also be used.

14.2 Preparation of pipe ends. The joint preparation for the pipe ends shall comply with the requirements of Table 3 appropriate to the welding technique adopted.

NOTE Although Table 3 provides for the welding of pipes with square cut ends, this requires a greater degree of skill on the part of the welder.

The ends shall be prepared by sawing, machining, grinding, machine gas cutting or by hand flame cutting with subsequent filing or grinding if necessary.

For pipes which are intended to be in axial alignment, the plane of the ends shall be square with the axis of the pipe. For pipes which are intentionally out of axial alignment, the plane of the joint shall bisect the angle between adjacent pipes.

Table 1 — Sizing and alignment

Outside diameter		Maximum permissible difference in internal diameter	Maximum out of alignment at the bore
Over	Up to and including		
mm	mm	mm	mm
—	42.4	1.0	1.0
42.4	114.3	2.0	1.0
114.3	—	3.0	2.0

Table 2 — Drifting of pipe ends

Outside diameter		Amount of expansion as percentage of diameter	Condition for expansion
Over	Up to and including		
mm	mm		
—	323.9	Not more than 3 %	Hot or cold (as desired)
		Over 3 %	Hot
323.9	—	All values	Hot

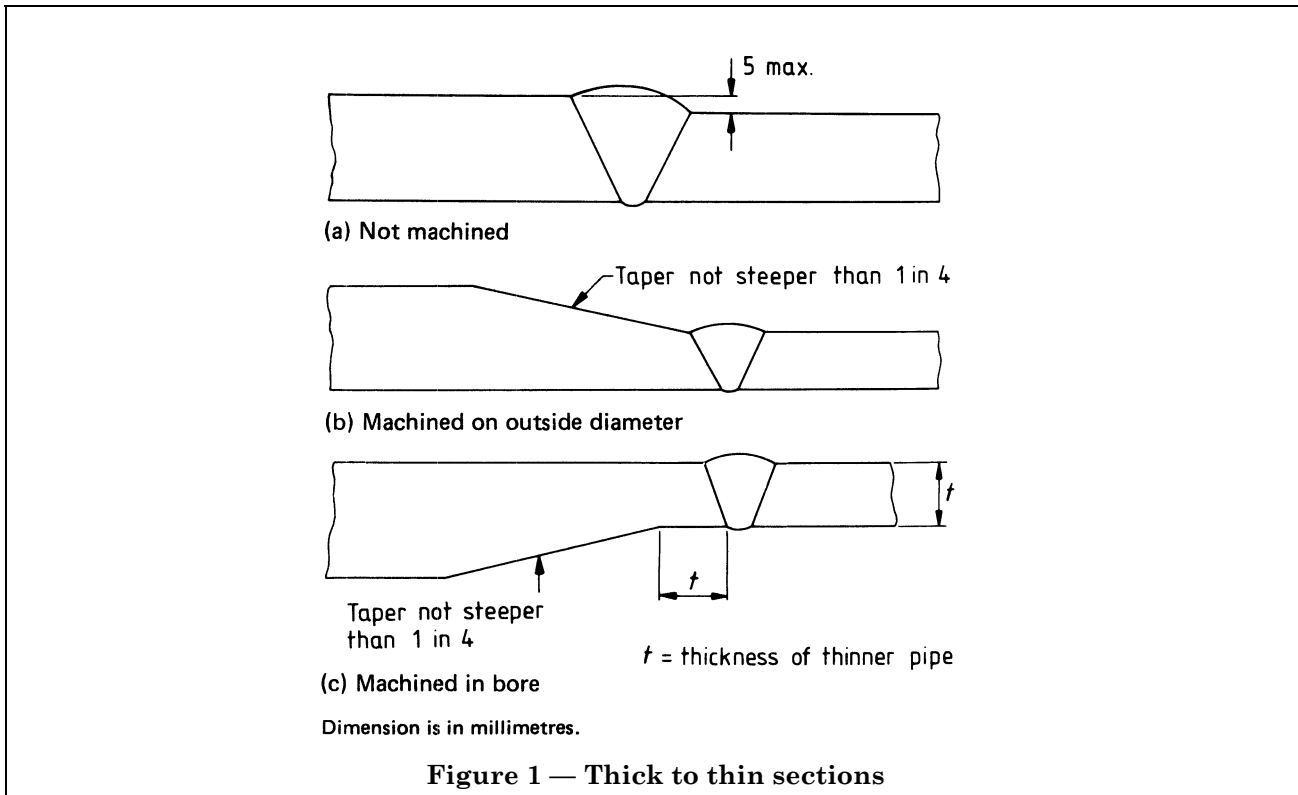

Table 3 — Preparation of ends

Technique	Thickness	Included angle of bevel	Root gap after tacking	Root face
Leftward	mm Less than 4.5	0°	mm 2.5 to 3.0	Not to exceed 1.6 mm where used
	4.5 to 5.5 inclusive	80° to 90°	2.0 to 3.0	
Rightward	Less than 5.0	0°	2.5 to 3.0	
	5.0 and over	60° to 70°	3.0 to 4.0	
All position rightward	Less than 5.0	0°	2.5 to 3.0	
	5.0 and over	50° to 60°	3.0 to 4.0	
Multilayer	—	60° to 80°	2.5 to 5.0	
Block welding	Over 5.0	60° to 80	2.5 to 5.0	

15 Gusseted bends

15.1 General. The service conditions for which gusseted bends may be used shall be the subject of agreement between the purchaser, the manufacturer and the inspecting authority, except where an application standard permits the use of such bends.

Gusseted bends are of the following types:

- Segmental*: separate pieces of pipe cut at an angle and welded together.
- Cut-and-shut*: wedge shaped pieces cut from one side of a pipe, the pipe pulled round until the cut edges come to the correct welding position and then welded.

15.2 Preparation

15.2.1 General. The preparation of any gusset for any gusseted bend shall be done by cutting the pipe end to the correct angle followed by the weld preparation as specified in 14.2.

To prepare the gussets for welding, all spatter, oxide and ragged edges shall be removed from the prepared edge and the bore of the pipes, the correct gap shall be set and the gussets tacked in position.

15.2.2 Segmental bends. The planes of ends of the separate pieces of pipe prepared for welding to form a segmental bend shall be inclined at the same angle to the axis of the piece.

The change of angle of the centreline at each cut shall not exceed approximately 30° except that right angle bends of radius equal to the inside diameter of the pipe made from pipe not exceeding 88.9 mm outside diameter may be made with a minimum to two cuts (see Figure 2).

For segmental right angle bends of radius equal to the inside diameter of the pipe, the dimensions of the segments at the throat of the bend shall be shown in Figure 2. The width of the segment at the throat of the bend measured at the outside diameter of the pipe shall not be less than 16.5 mm.

15.2.3 Cut-and-shut bends. A cut-and-shut bend shall have the angle of cut equally disposed about a line at right angles to the axis of the pipe (see Figure 3).

15.3 Welding procedure. A weld in a gusseted bend shall be treated as a butt weld and the requirements of clauses 9 and 13 and 14.2 shall apply.

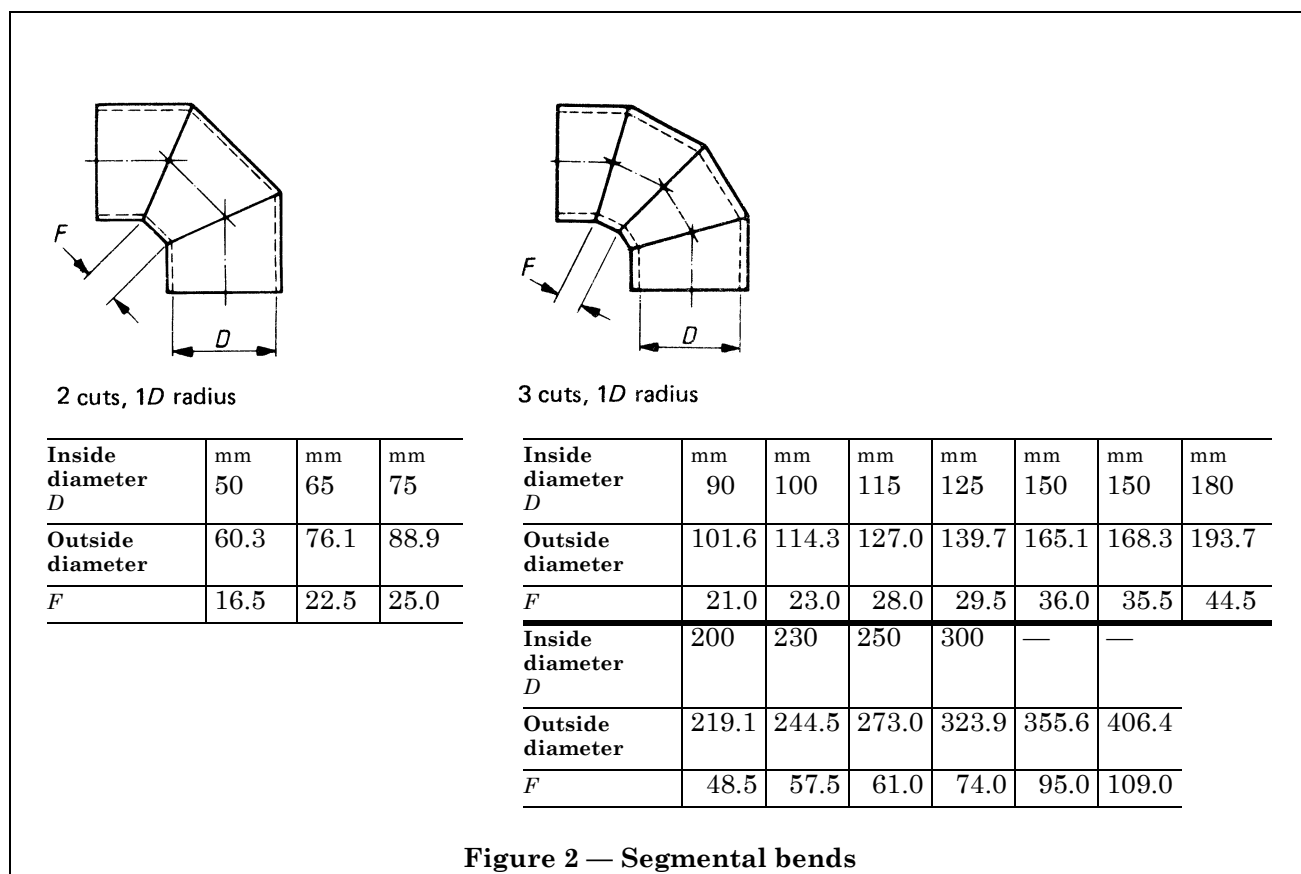

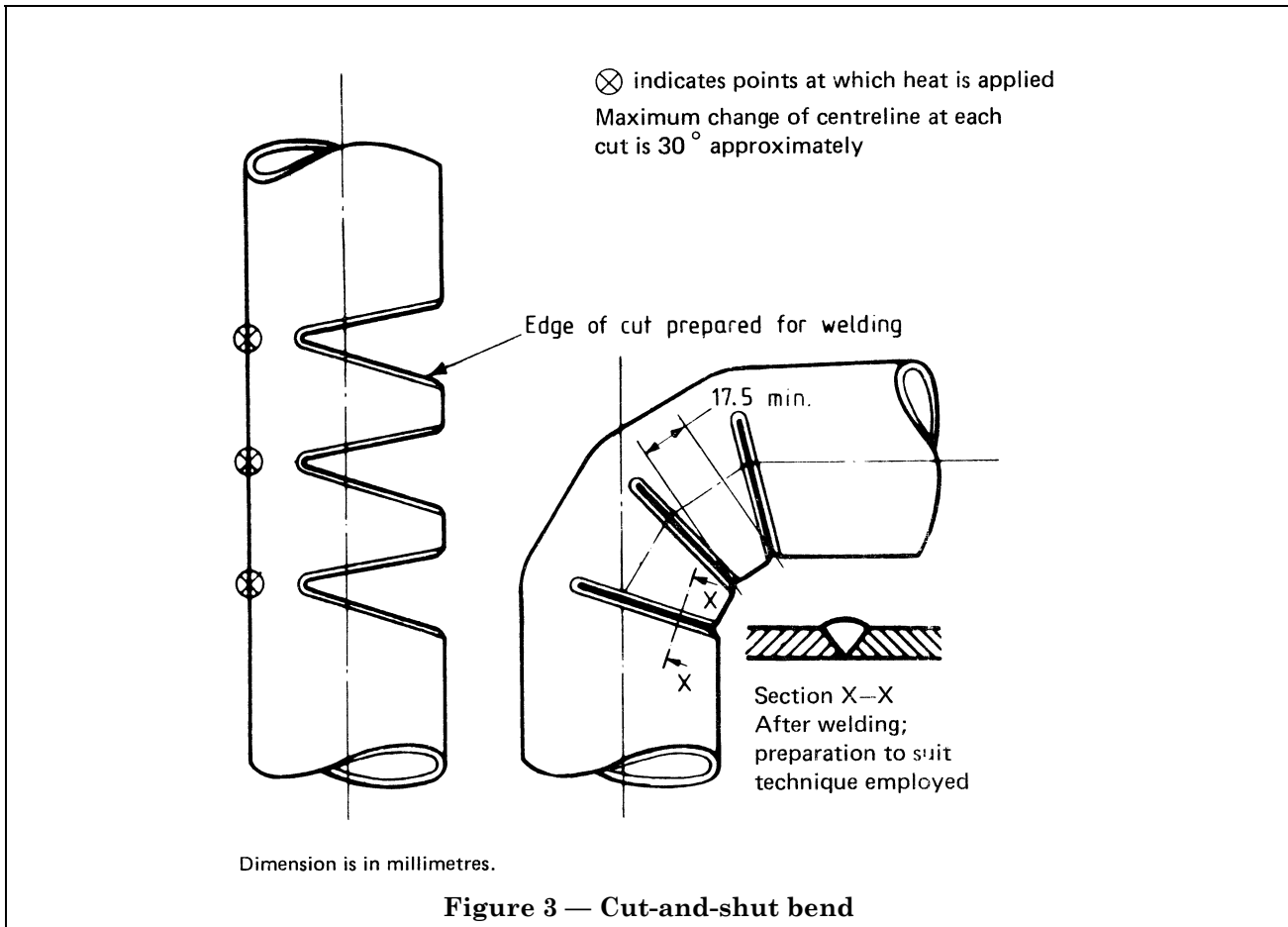

Section 3. Branches

16 General

Section 1 of this standard details the basic procedure requirements with which all welded joints between pipes and fittings shall comply. For branches that are made from pipe, tube or bar, the basic requirements are supplemented by the specific requirements detailed in this section 3. Both section 1 and section 3 of this standard shall be applied in determining the full procedure requirements.

NOTE 1 Any devices attached for the purposes of compensation should generally be welded by the metal-arc process (see BS 2971).

NOTE 2 It is preferable that branches should be fabricated at the works. Under site conditions, special precautions may have to be taken to prevent scale and oxide from the cutting operation lodging in the pipe.

17 All types of branches

17.1 Angle of branch. In view of the additional difficulty involved in making a satisfactory joint at the intersection of two pipes not at right angles, for branch pipes sloping away from a main, preference shall be given to using a right angle branch and a bend to give the required slope.

Where a sloping branch has to be connected directly to the main, the angle between the centreline of the main and that of the branch shall be not less than 60°. See Figure 4 for the case of a curved branch joint.

NOTE Owing to the difficulty of access for oxy-acetylene welding, sloping branches in which the angle between the main and the branch is less than 60° do not come within the scope of this standard.

17.2 Spacing of branches. Spacing of branches on the main pipe shall be such that there is adequate access for satisfactory welding. (See also clause 7.)

17.3 Minimum height of flanged branches. The shortest distance between the outside of the main pipe and the face of the flange shall be not less than one-half of the flange diameter or 100 mm, whichever is the greater (see Figure 5).

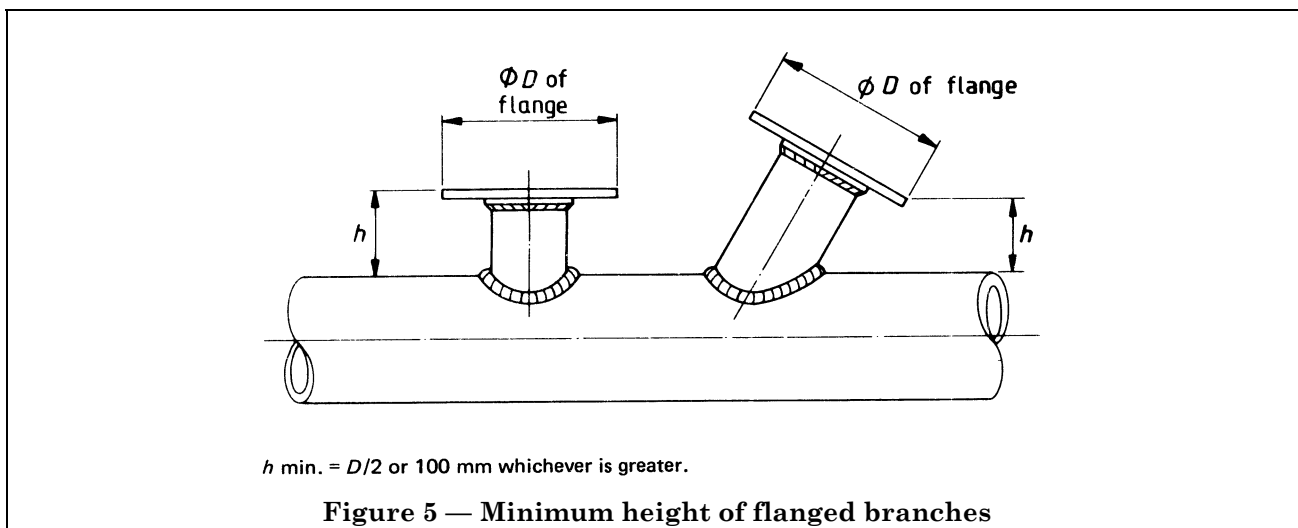
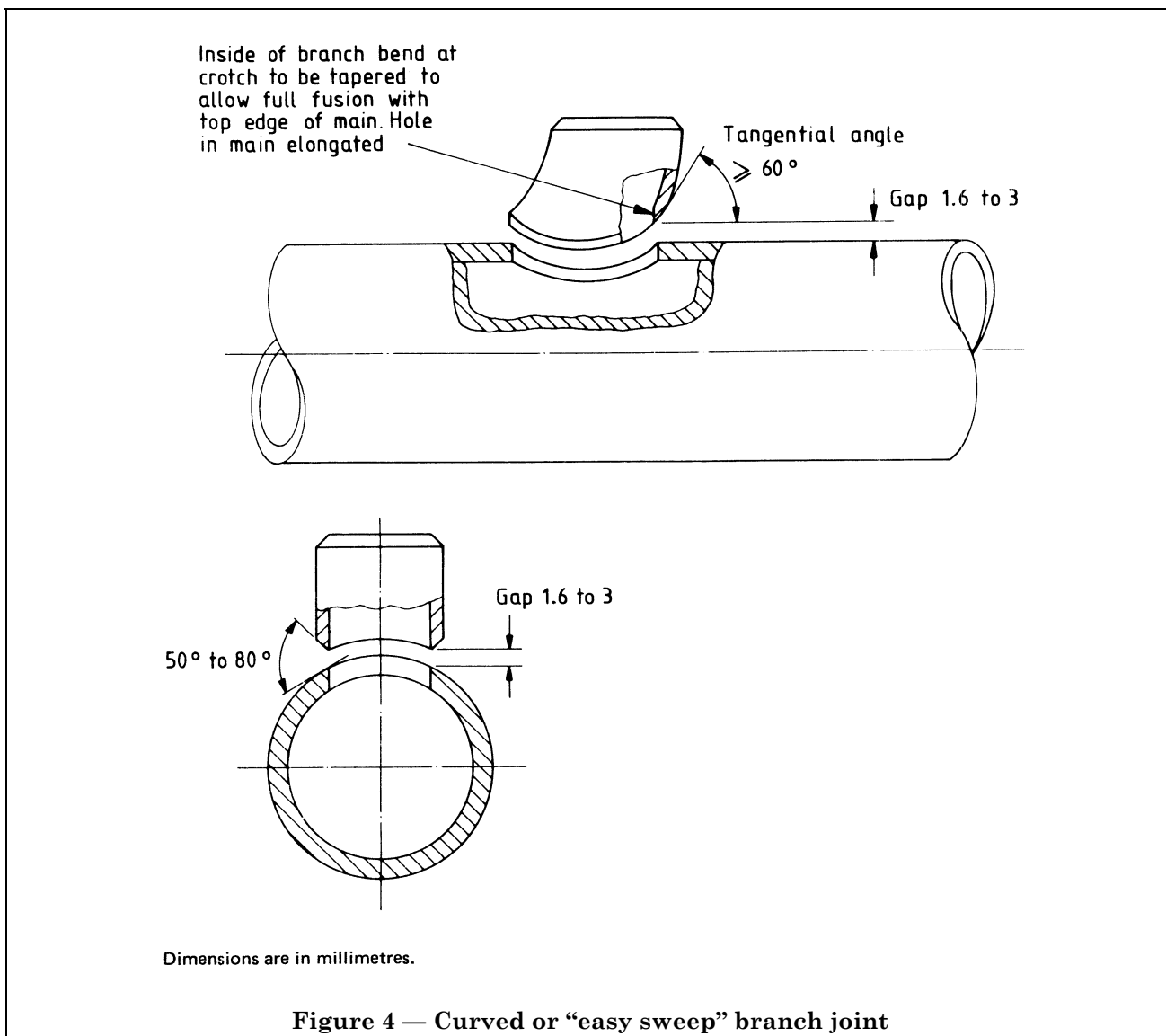

18 Set-on branches

Holes in pipes to receive set-on branches shall be cut by machining or flame cutting. The edges shall then be dressed by chipping, filing or grinding to remove any roughness and to produce the edge shapes shown in Figure 6. Special precautions as indicated in Figure 6 shall be taken locally at the acute crotch to ensure a sound weld. The size of the hole shall be made to suit the measured bore of the branch pipe and should preferably match exactly; in each case the average out-of-alignment at the bore of the branch shall not exceed that shown in Figure 6.

The ends of branches shall be cut by machining or flame cutting. The edges shall then be dressed by chipping, filing or grinding to produce a bevel, with no root face as shown in Figure 6.

The sequence of welding shall be such that the specified gap is maintained.

19 Set-in branches

The joint details for set-in prefabricated equal branches shall be as shown in Figure 7. The diameter of the hole in the main pipe shall be equal to the bore of the branch. Joint preparation shall be by flame cutting and shaping the hole in the main pipe, and the end of the branch to be joined to the pipe. The gap between the main pipe and the branch at the base of the welding "V" shall be not less than 1.6 mm and not more than 3.0 mm.

Tack welding in the groove for assembly shall be the minimum practicable.

Section X-X
at crotch of
right angle branch

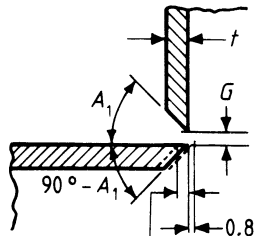

Out of alignment
not to exceed 1.6 all round

Section Y-Y
at flank of
unequal branch

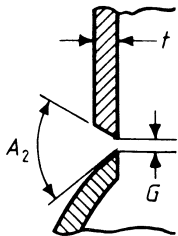

Section W-W
at flank of
equal branch

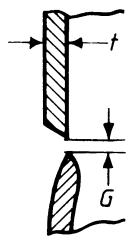

Section Q-Q
at back of
sloping branch

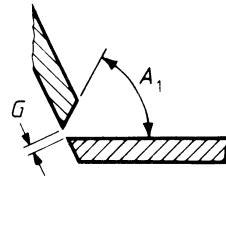

Section Z-Z
at crotch of
sloping branch

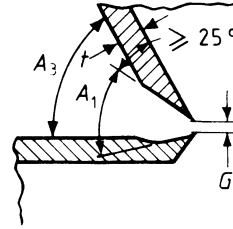

Technique	Leftward	Rightward, all position rightward or multi- layer
Max. wall thickness of branch for single run, t	4.5 mm	6.3 mm
Included angle of bevel at crotch, A_1	60° min.	45° min.
Included angle of bevel at flank, A_2	80° min.	50° min.
Minimum angle of sloping branch, A_3	75°	60°
Gap, G	1.6 mm	3.0 mm

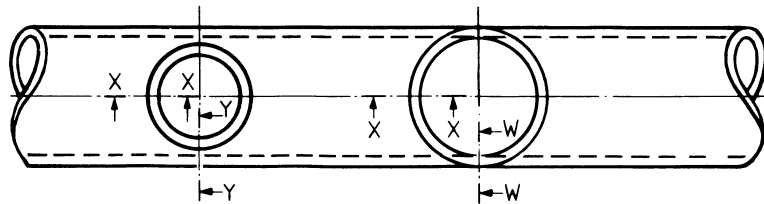
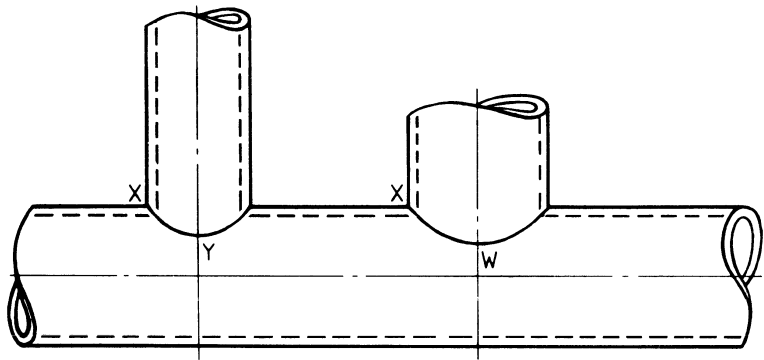

Linear dimensions are in millimetres.

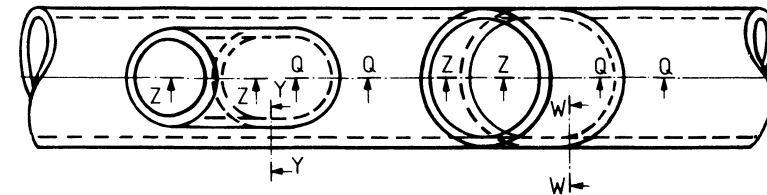
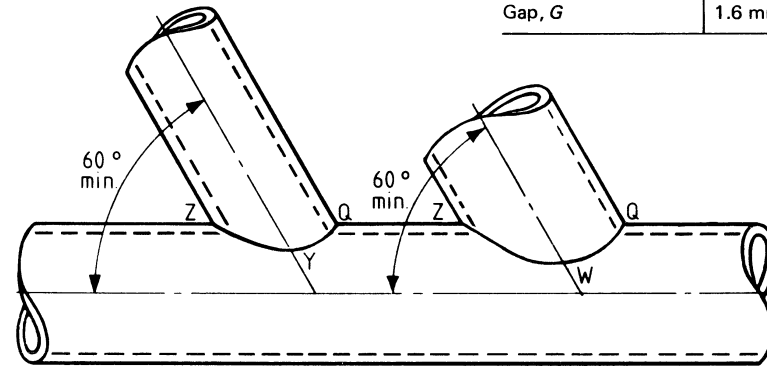
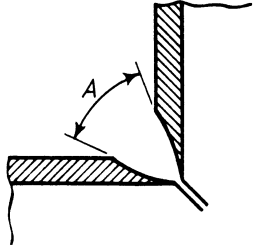
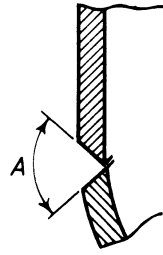

Figure 6 — Details of set-on branches

Section X-X
at crotch of
right angle branch



Section W-W
at flank of
equal branch



Section Q-Q
at back of
sloping branch

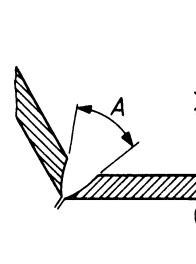

Section Z-Z
at crotch of
sloping branch

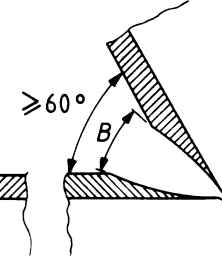

Note: A not less than 45°
 B not less than 30°

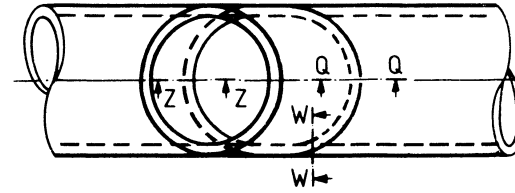
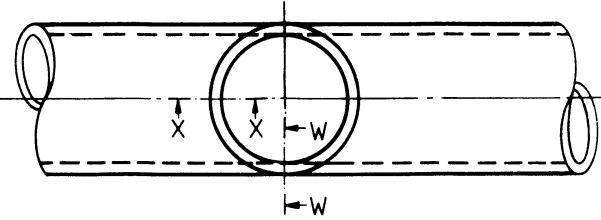
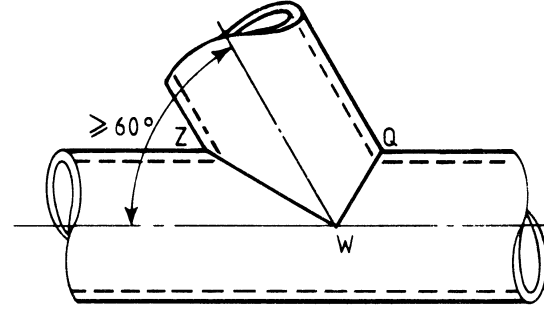
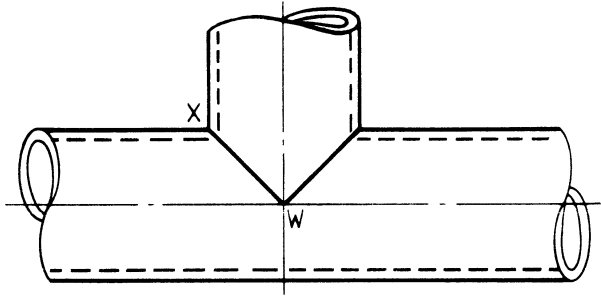
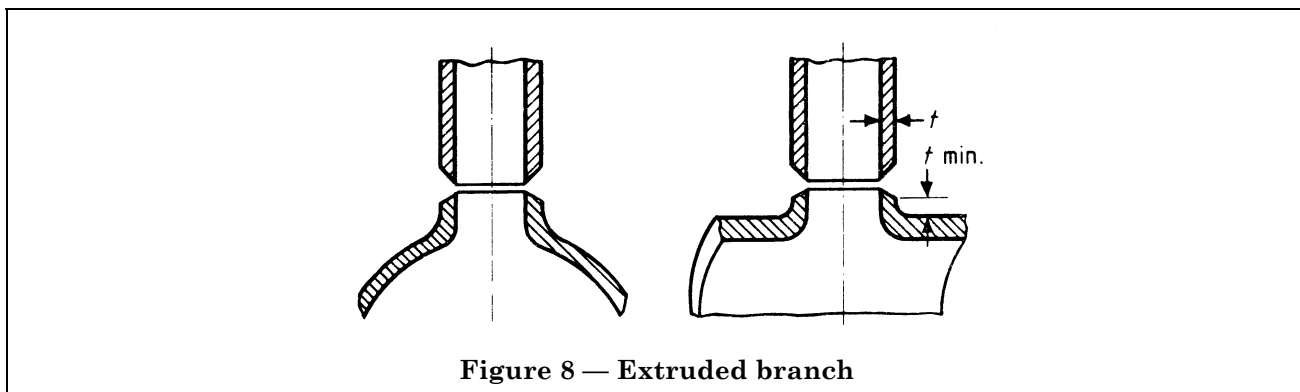

Figure 7 — Details of set-in branches

20 Extruded branches

Extruded branches shall be of the type illustrated in Figure 8. The length of stub to the shoulder of the weld bevel shall be not less than the thickness of the branch.

The joint shall comply with the requirements for butt joints specified in section 2, the general requirements of section 1 and the requirements of clause 17.



21 Forged fittings

Forged fittings of the type illustrated in Figure 9, complying with the requirements of BS 1640-3, may be used by agreement between the purchaser and the manufacturer.

The joint shall comply with the requirements for butt joints specified in section 2, the general requirements of section 1 and the requirements of clause 17.

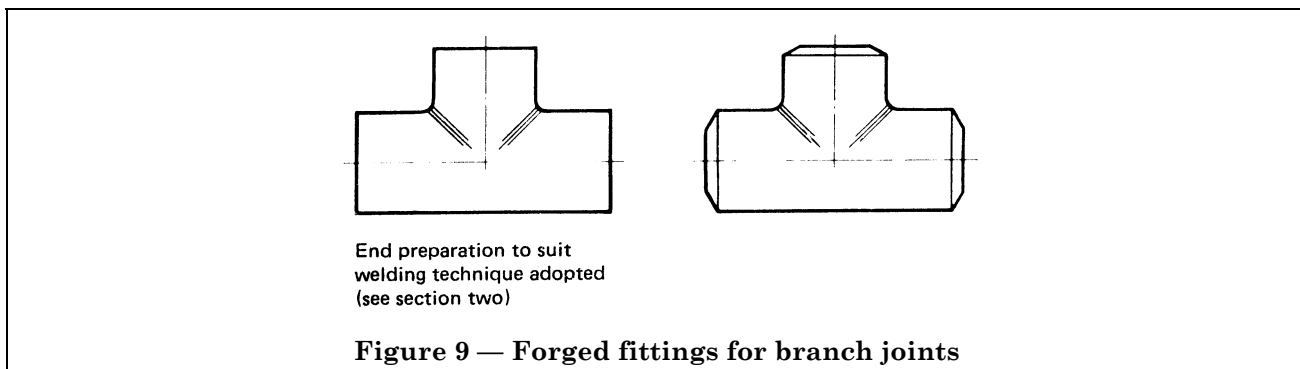

Section 4. Sleeve joints and socket-welding fittings

22 General

Section 1 of this standard details the basic procedure requirements with which all welded joints between pipes and fittings shall comply. These basic requirements are supplemented by the specific requirements detailed in this section 4. Both section 1 and section 4 of this standard shall be applied in determining the full procedure requirements.

23 Sleeve joint details

A sleeve joint is formed when the end of one pipe enters the swelled end of another pipe and the two pipes are joined by means of a fillet weld.

The joint shall be one, of the types shown in Figure 10. The pipes jointed as shown shall have the ends sized and gauged to ensure that the spigot will freely enter the sleeve and thereafter be capable of being forced home so that the spigot end will tighten itself in the sleeve.

No melting of the corners shall be allowed to occur to such an extent as to reduce the throat thickness of the fillet weld (see Figure 11).

24 Socket joint details

A socket joint is formed when the end of a pipe enters the socket end of a socket-welding fitting and the pipe and socket are joined by means of a fillet weld.

Forged socket-welding fittings when used within the limitations in the appropriate application standard shall be in accordance with the requirements of BS 3799.

NOTE Socket-welding fittings may be machined from bar of suitable composition and quality.

Preparation and assembly of the joint for welding shall be such as to ensure that the pipe end is axially square to the base of the fitting and that there is a gap of approximately 2 mm between the pipe end and the base of the fitting (see Figure 12). To achieve this gap, the pipe end shall first be fully inserted and the outside surface of the pipe marked in line with the end face of the socket. The pipe shall then be withdrawn approximately 2 mm before welding. The diametral clearance between the outside diameter of the pipe and the bore of the fitting shall not exceed 1.5 mm.

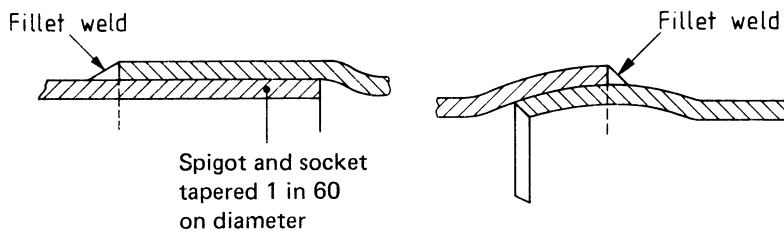
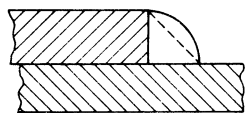
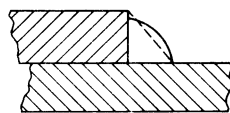

Figure 10 — Sleeve joints



(a) Desirable



(b) Acceptable because of full throat thickness

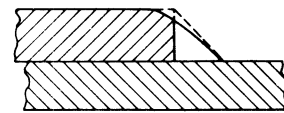

(c) Not acceptable because of reduced throat thickness

Figure 11 — Fillet welds for sleeve joints

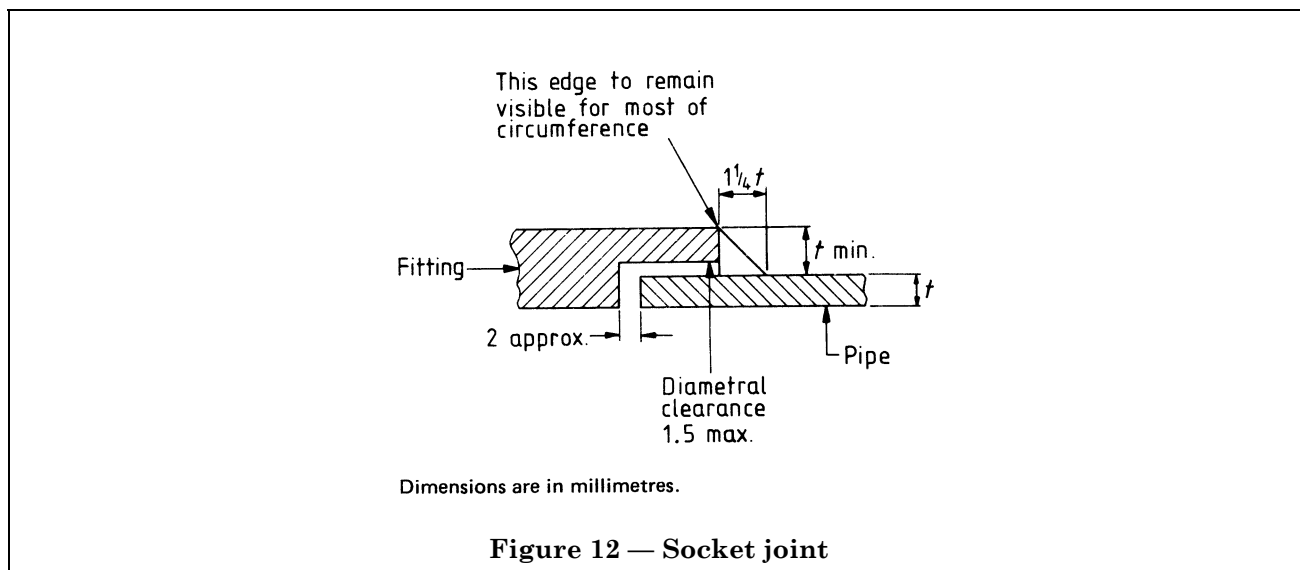

Section 5. Structural attachments

25 General

Section 1 of this standard details the basic procedure requirements with which all welded joints between pipes and fittings shall comply. These basic requirements are supplemented by the specific requirements detailed in this section 5. Both section 1 and section 5 of this standard shall be applied in determining the full procedure requirements.

Attachments to pressure parts that are primarily designed as load carrying members shall comply with the requirements of this section.

NOTE For the design of attachments the relevant application standard should be consulted.

26 Welding procedure

Each run of weld metal shall be clean and free from scale before the next run is deposited. To ensure full penetration in a double sided weld, the under surface of the root run shall be removed, by chipping or grinding, to give a clean metallic surface, before welding from the other side is commenced.

If partial penetration welds are used, the form of the preparation shall be specified on the drawings. The method and amount of inspection shall be agreed between the purchaser and the manufacturer.

On thin walled tubes care shall be taken to avoid burn-through into the bore of the tube.

Section 6. Flanges

27 General

Section 1 of this standard details the basic procedure requirements with which all welded joints between pipes and fittings shall comply. These basic requirements are supplemented by the specific requirements detailed in this section 6. Both section 1 and section 6 of this standard shall be applied in determining the full procedure requirements.

28 Welding neck flanges

The procedure to be applied for the welding of welding neck flanges (see Figure 13) shall be the same as for normal butt welds, for which the requirements of section 2 shall apply.

29 Welded-on flanges

The flange shall be bossed as shown in Figure 14. The flange should be substantially concentric with the pipe. The flange shall be a loose fit on the pipe but the clearance between the outside diameter of the pipe and bore of the flange shall not exceed 3.0 mm at any point and the sum of the clearances, on any diameter shall not exceed 5.0 mm. The leg lengths of the fillet welds shall be aligned to suit the actual amount of clearance existing.

Plate flanges shall not be welded by the oxy-acetylene process. (See BS 2971).

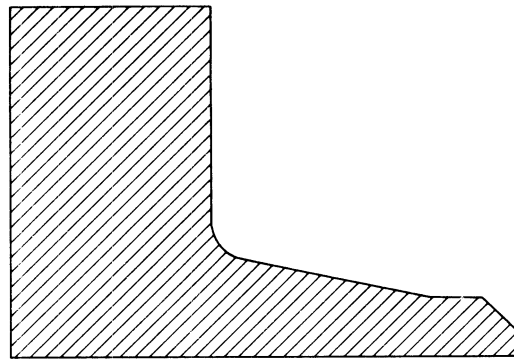

Figure 13 — Welding neck flange

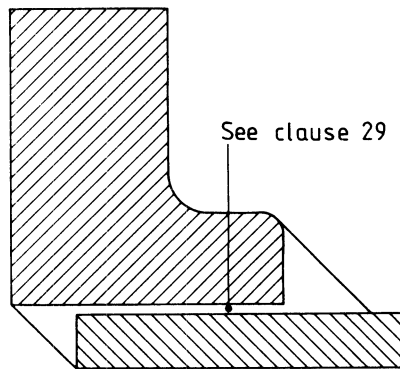

Figure 14 — "Slip-on" hubbed welded-on flange

Section 7. Inspection requirements

30 Requirements for visual examination of completed welds

30.1 General. All welds shall be visually examined on the outside surface and, where practicable, in the bore (with the aid of optical instruments if necessary) and shall show the features detailed in **30.2**, **30.3** and **30.4**.

Visually detectable imperfections shall be assessed in accordance with the requirements of **30.2**.

30.2 Profile of external surface. Weld metal shall be properly fused with the parent metal. However, defects such as undercutting and overlapping at the toes of the weld may be disregarded provided that either or both do not exceed a total of 25 mm in any 100 mm length of weld. Undercutting, irrespective of length, shall not exceed a depth of 20 % of the nominal pipe thickness.

There shall be external weld reinforcement, preferably between 1.5 mm and 5 mm high measured from the outer surface of the parent metal, and this reinforcement shall be substantially symmetrical about the centreline of the joint. The shape of the reinforcement may vary according to the type of filler metal used, the welding technique and the welding position, but in all cases shall be of smooth contour.

The surface of the weld shall be free from porosity, cavities and loose or excessive scale.

30.3 Smoothness of the weld. The stop and start of each run of weld shall merge smoothly, and shall show no pronounced hump or crater in the weld surface.

30.4 Profile of internal surface. The weld shall fuse the pipe at the root without protruding excessively into the bore of the pipe. The penetration bead shall not exceed 3.0 mm for pipes up to and including 150 mm nominal size or 6.0 mm for pipes over 150 mm nominal size.

If there is complete root fusion, root concavity (or sink-age) at the bore is acceptable provided that

- a) the bore surface of the joint is of smooth contour;
- b) the thickness of the weld is not less than the pipe thickness.

31 Testing of completed welds

The use and extent of both destructive and non-destructive testing of completed welds shall be in accordance with the requirements either specified in the relevant application standard or agreed between the purchaser and the manufacturer at the enquiry and order stage.

32 Non-destructive testing of butt joints

32.1 General. Radiographic (see BS 2910) or ultrasonic (see BS 3923-1) examination of butt joints in accordance with section 2 shall be employed only when its use and extent are specified in the relevant application standard or are agreed between the purchaser and the manufacturer at the enquiry and order stage. When such examination is used, the fault limitations specified in **32.2** shall apply. The inspection, testing and acceptance requirements for other than butt joints in accordance with section 2 shall be agreed between the contracting parties.

NOTE 1 In using radiographic or ultrasonic examination for the assessment of class II welds, attention is drawn to the fact that apart from weld metal quality, the indication of improper joint set-up (e.g. close butting or gross misalignment) could of itself be cause for rejection since such a condition may not meet the requirements of this standard.

NOTE 2 Multiple-type faults contained within the same weld, either superimposed or interposed, which are individually acceptable as isolated imperfections, should be considered collectively by the inspector when assessing weld quality.

NOTE 3 When non-destructive testing is to be employed, the extent should relate to a percentage of complete butt joints and not a part of all joints.

32.2 Fault limitations. Any ONE of the following imperfections shall be sufficient cause for rejection.

- a) Any type of crack.
- b) Misalignment exceeding the limits given in Table 1.
- c) Root penetration and concavity: the requirements of **30.4** apply.
- d) Lack of penetration
Lack of side wall fusion
Lack of inter-run fusion
Circumferential wormholes

}	Total length exceeding 25 mm in any 100 mm length of weld, or height greater than 20 % of nominal pipe thickness.
---	---
- e) Porosity
 - 1) *Isolated gas pores.* Any individual spherical gas pore whose maximum diameter exceeds 3.0 mm or 25 % of wall thickness, whichever is the smaller.
 - 2) *Scattered gas pores.* Smaller than those permitted in 1), the diameter of which in aggregate exceed 10 mm in any 25 mm length of weld. The distance between any two adjacent pores shall be not less than three time the diameter of the larger pore.
 - 3) *Localized porosity (i.e. stop-start porosity).* Any circle 8 mm in diameter in which the total area of individually acceptable randomly distributed gas pores exceeds the equivalent area of six pores 0.8 mm in diameter.

32.3 Re-examination. When random radiographic or ultrasonic examination of all or part of a weld reveals unacceptable defects, one further weld in the group represented by this weld shall be so tested to the same extent. If this further weld shows no unacceptable defects, the defects in the first weld shall be repaired and then re-examined by the original method. If the repair is satisfactory, the group of welds shall be accepted.

If the further weld shows unacceptable defects, each weld in the group shall be examined by the same method and to the same extent. Unacceptable defects shall be repaired and then re-examined by the original method.

Section 8. Rectification of faulty welds

33 Removal of faults

Where welds fail to comply wholly or in part with the requirements of section 7, all unacceptable defects shall be removed.

Defects shall be removed by chipping, grinding, machining, thermal cutting or thermal gouging.

Major repairs may involve:

- a) cutting through the weld, or
- b) cutting out a length of pipe containing the weld.

A cut through a weld as in a) above, or through the pipe as in b) above, shall be made by machine thermal cutting, guided hand thermal cutting, saw cutting or machine cutting. If thermal cutting is used, it may be necessary to compensate for any loss of length that may occur. The amount of material to be removed from the cut faces after thermal cutting shall be such that a smooth surface free from serrations is obtained.

34 Preparation for re-welding

34.1 General. Any repair to a weld shall be reported to the inspecting authority. If the repair is made as a consequence of non-destructive testing, the records relating to the original defects shall be made available.

34.2 Partial removal of weld. The cut out portion shall be sufficiently deep and long to remove the defect. At the ends and sides of the cut there shall be a gradual taper from the base of the cut to the surface of the weld metal.

The width and profile of cut shall be such as will give adequate access for re-welding. (See Figure 15.)

If the root of the weld is accessible from the bore of the pipe, a repair may be made from that position.

34.3 Complete removal of weld. Where a cut has been made through a faulty weld and there has been no serious loss of pipe length, the weld preparation shall be re-made in accordance with the appropriate section of this standard.

When it is necessary to compensate for loss of pipe length, this shall be done:

- a) by inserting a new length of pipe and preparing the two joints required as described in section 2; or
- b) by building up the base of the groove with suitable weld metal; or
- c) by adopting a joint preparation incorporating a wider root gap, provided agreement between the contracting parties is obtained on the use of this method.

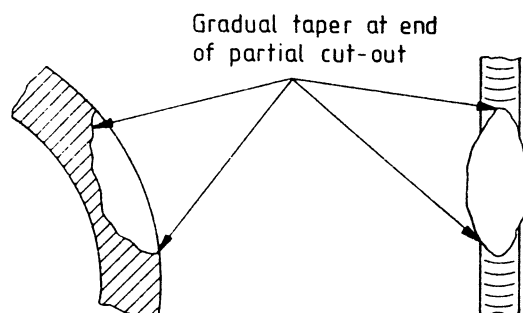

Figure 15 — Partial cut-out in rectification of faulty welds

35 Re-welding

Before re-welding, the repair procedure shall have been approved by the inspecting authority or the purchaser if it differs significantly from the original welding procedure.

As a minimum requirement a repaired weld shall be subjected to the same testing and inspection requirements as the original weld.

Section 9. Welding procedure approval

36 General

36.1 If required by the purchaser or by the application standard, the manufacturer shall, at the enquiry and order stage, submit written welding procedure specifications (see Appendix A) in accordance with BS EN 288-2. (In the absence of a European standard for oxy-acetylene welding.)

36.2 When, according to **36.1**, welding procedure specifications are to be provided, the purchaser or the application standard shall state at the enquiry and order stage whether or not approved welding procedure specifications are required to be used (see Appendix A).

NOTE Provided a welding procedure specification is submitted, it is recommended that an approved welding procedure is not required when any of the steels covered by the following list of standards and grades is employed:

Standards	Grades
BS 1387	
BS 3059-1	320
BS 3059-2	360
BS 3601	320 and 360
BS 3602-2	360
BS 3606	320

36.3 When, according to **36.2**, approved welding procedure specifications are required the manufacturer shall, prior to commencing production welding produce welding procedures approved in accordance with BS EN 288 as defined below:

Welding shall be controlled by reference to BS EN 288 as defined below.

All welding shall be performed in accordance with the welding procedure specification or other work instruction written in accordance with BS EN 288-2. These welding procedure specifications shall be substantiated by a welding procedure test either:

- 1) in accordance with BS EN 288-3 or
- 2) a pre-existing weld procedure test performed to BS 4870-1 previously acceptable to an examiner or test body except that the range of approval of this test shall be in accordance with the ranges in BS EN 288-3.

Existing procedures to BS 4870-1 shall be considered technically equivalent to BS EN 288-3 when similar types of test have been carried out. Thus, the bend tests in BS 4870-1 shall be considered equivalent to those in BS EN 288-3 even though the exact number and bend angle differ. Similarly, visual, radiographic, ultrasonic, surface crack detection, transverse tensile, hardness, macro-examination and impact tests shall be considered equivalent.

Where BS EN 288-3 calls for a type of test to be performed and this has not been carried out on the pre-existing BS 4870-1 procedure qualification test, additional testing, as described in clause 0 of BS EN 288-3 shall be carried out. For example, if impact tests have not been carried out on the BS 4870-1 test piece it is only necessary to do an additional set of impact tests on a test piece made in accordance with BS EN 288-3.

The alternative methods of approval of welding procedures addressed in BS EN 288-1 shall not be permitted for pipe welding in accordance with BS 2640. By agreement, where specific joint types are not compatible with the testing requirements of BS EN 288-3 then a pre-production test shall be considered and shall be subjected to the relevant tests of BS E/1288-3 where practicable.

When the purchaser requires that welding procedure tests employ pipe at specified diameter and thickness such a requirement shall be stated on the enquiry and order (see Appendix B).

NOTE It is recommended that welding procedure tests carried out in accordance with this clause and witnessed by an examiner or test body should be accepted by other examiners or test bodies provided that all the provisions have been fulfilled.

37 Attachments to thin pipes

When attachment welds are to be made to pipes equal to or less than 5 mm wall thickness a test shall be made using a typical weld detail to determine that burn-through does not occur. The test weld shall be made on pipe of contract thickness and the minimum approved thickness is that thickness welded.

NOTE The approval may apply to other contracts.

Section 10. Welder approval

38 General

For the manufacture and erection of pipework made in accordance with this British Standard, welders shall be employed who satisfy one of the following alternatives.

- a) Have satisfactorily carried out the relevant welder approval tests in accordance with BS 4872-1 (see clause 42). If non destructive testing is required on the contract, the test welds submitted for welder approval shall have been similarly non-destructive tested prior to taking test specimens and results assessed in accordance with clause 32.
- b) Approval testing of welders shall be carried out in accordance with BS EN 287-1. Welders who previously held approvals to BS 4871-1 shall be considered to be approved to work with the following provisos.
 - i) The range of approval of the welder shall be in accordance with BS EN 287-1.
 - ii) Welder approval tests to BS 4871-1 shall be considered technically equivalent to BS EN 287-1.
 - iii) The prolongation of a BS 4871-1 approval test, if required, shall be made at 6 monthly intervals by the employer/manufacturer, in accordance with 10.1 of BS EN 287-1 1992 for the period of 2 years from the date of effect of BS EN 287-1 i.e. from 1 May 1992.
 - iv) The prolongation of a BS 4871-1 approval test in excess of the initial 2 years from 1 May 1992 shall be made in accordance with 10.2 of BS EN 287-1 1992 in conjunction with an examiner or test body.
- c) The welder who satisfactorily completes the welding procedure test shall thereby be approved in those procedures without undergoing welder approval tests except for fillet welds where the extra tests required by BS EN 287-1 (2 macros or test piece fracture) shall be completed.

NOTE It is recommended that welder approval tests carried out in accordance with the requirements of this clause and witnessed by an examiner or test body should be accepted by other examiners or test bodies provided that all the provisions have been fulfilled.

39 *deleted*

40 Attachments to thin pipes

Welders to be engaged in welding attachments to pipes equal or less than 5 mm thickness shall demonstrate their ability. The test weld shall be made of contract thickness and the minimum approved thickness shall be the thickness welded.

Appendix A Classes of operating conditions

The table below gives guidance on class I and class II operating conditions of pipework which, as stated in the foreword, are only one set of factors that have to be taken into account in deciding the class of welding required for a particular application.

Service	Class I	Class II
Gases and steam	Over 17 bar ^a or over 220 °C	Up to and including 17 bar and up to and including 220 °C
Liquids	Over 17 bar and over 95 °C	Up to and including 17 bar and up to and including 200 °C
	Over 24 bar or over 200 °C	Over 17 bar up to and including 24 and up to and including 95 °C
All fluids	Over 17 bar and below – 20 °C	Up to and including 17 bar and below – 20 °C
^a 1 bar = 10 ⁵ N/m ² = 100 kPa.		

Appendix B Items for agreement between the contracting parties

The following items, where applicable, are for agreement between the contracting parties at the time of the enquiry and/or order.

- a) The precautions in inspection and welding procedure required when welding cast parts (clause 3).
- b) The precautions to be taken when more than two welded joints meet (clause 7).
- c) The modification of requirements for root gap (clause 9).
- d) The details relating to post-weld heat treatment when its use is required by the purchaser (clause 11).
- e) The service conditions for gusseted bends (15.1).
- f) The use of forged tees (clause 16).
- g) The inspection requirements for structural attachments using partial penetration welds (clause 26).
- h) The use and extent of destructive and non-destructive testing (clause 31).
- i) The use and extent of radiographic or ultrasonic examination (32.1).
- j) The inspection and testing requirements for other than butt joints (32.1).
- k) The use of a wide gap for a repair weld [34.3 c)].

Appendix C Welding techniques

C.1 Rightward technique. The rightward method of welding is that process by which a right-hand welder proceeds from left to right, the blowpipe flame being directed towards the completed part of the weld. In its execution the welder keeps the filler rod in the weld puddle and moves it from side to side of the puddle. The blowpipe nozzle should be directed to the bottom of the weld, and kept relatively steady, proceeding only from left to right while the flame is impinging upon the “V” and the molten puddle (see Figure 16).

C.2 All-position rightward technique. This technique is applicable to joints in fixed pipes with the pipe centreline in any plane. For downward welding it is identical with the normal rightward technique, except that the included angle of bevel of 50° to 60° specified in Table 3 will be encountered in the flat position of a pipe in place of 60° to 70° specified for normal rightward welding.

In the all-position rightward technique the flame precedes the rod along the weld and is directed to the root of the weld as in the normal rightward technique, but the blow-pipe and rod angle vary for the different positions. The flame proceeds steadily forward with little side motion, the rod being given a side-to-side and an occasional stirring motion.

Typical positions of blowpipe and rod are indicated in Figure 17.

C.3 Leftward technique. The leftward method of welding is that process by which a right-hand welder proceeds from right to left with the blowpipe flame directed towards the uncompleted part of the joint. In its execution the blow-pipe is moved slightly from side to side, creating fusion in the parent metal, and the filler rod is then applied and the molten metal is deposited on to the fused portion (see Figure 18).

The direction of welding in the overhead and vertical positions are as for all-position rightward, but in the horizontal-vertical position the direction is from right to left.

C.4 Multi-layer technique. The multi-layer technique may be used for all thicknesses of pipe. The first layer should be put down either by the rightward or by the all-position rightward method.

The second and subsequent layers, both for horizontal and for vertical pipes, should be welded by the leftward, rightward or all-position rightward technique, as preferred. Typical positions of blowpipe and rod are indicated in Figure 19.

Welding may be interrupted with the groove partially filled provided the thickness of the weld metal deposited is not less than half the thickness of the pipe at any point on the circumference.

C.5 Block-welding technique. Block-welding may be applied as an alternative to multi-layer welding on any thickness of pipe over 8 mm and on all positions of joint.

The welding of the first layer is carried out in short sections of 50 mm to 100 mm by the rightward or all-position rightward method. The joint is then built up to the finished height, including the reinforcement, on the short section of first run, leaving each layer projecting in the form of a step to facilitate continuing the weld to form the next block (see Figure 20).

With this method, the joint should not be allowed to cool down when the weld is in a partially finished condition, otherwise cracking is very liable to occur at the end of the first layer at "A" (in Figure 20).

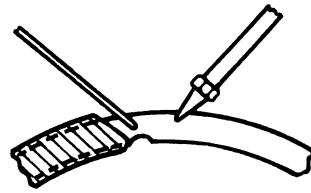

Sectional elevation.

Figure 16 — Rightward (or backward) technique

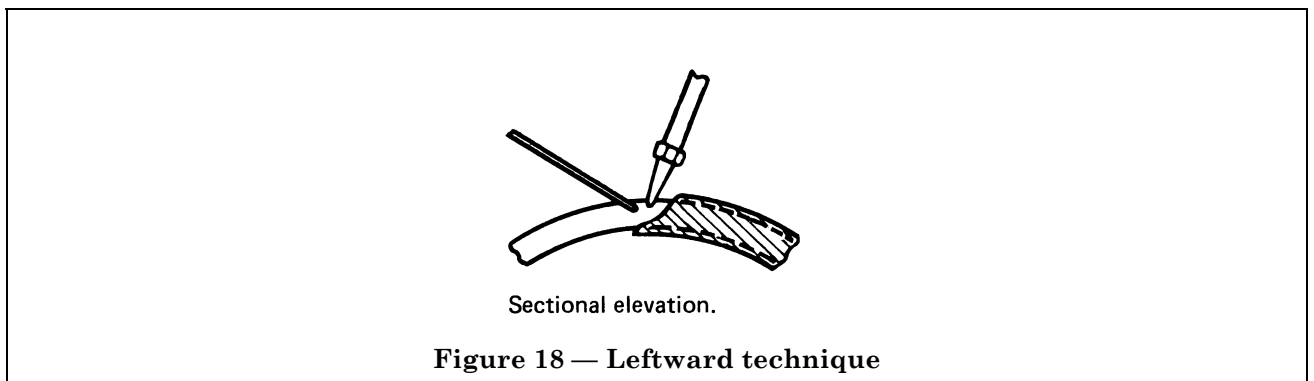
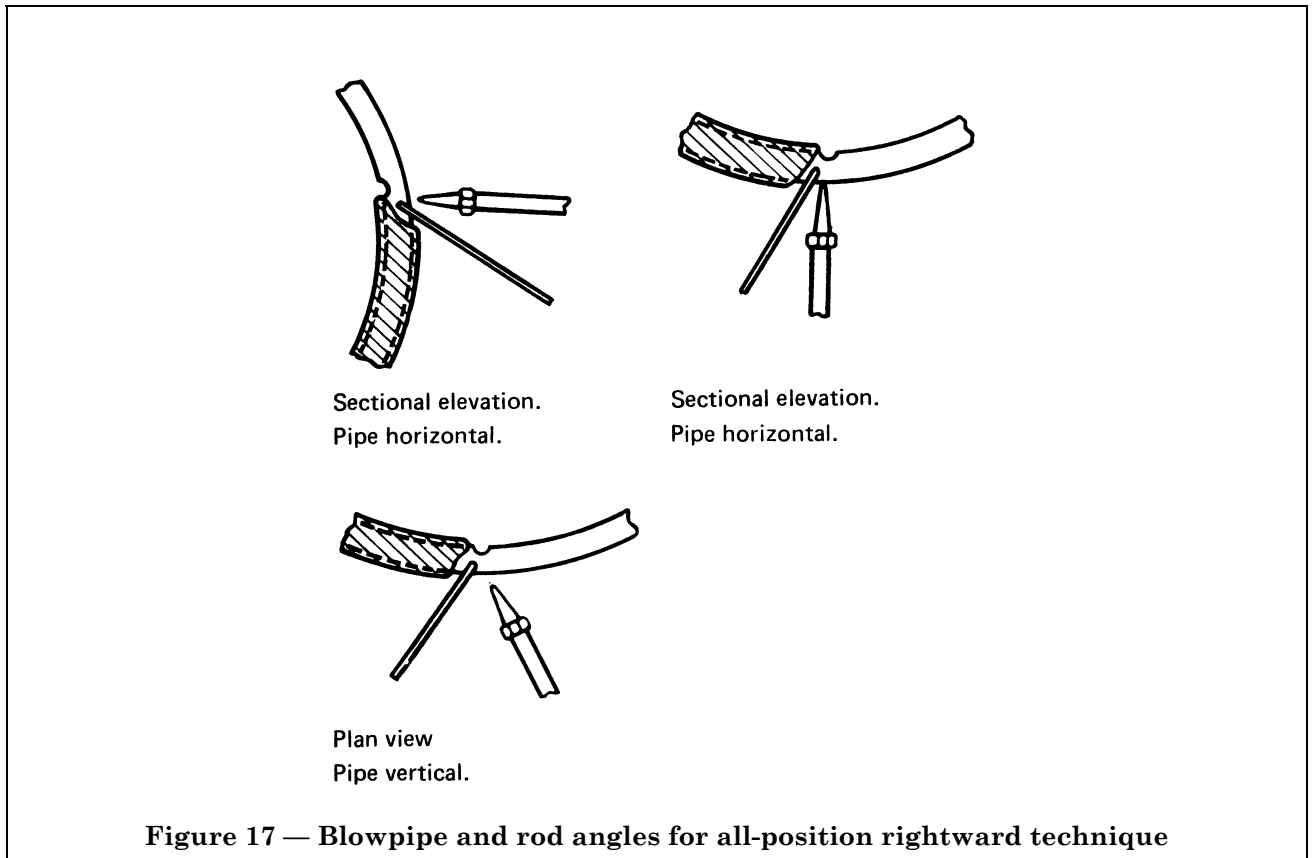

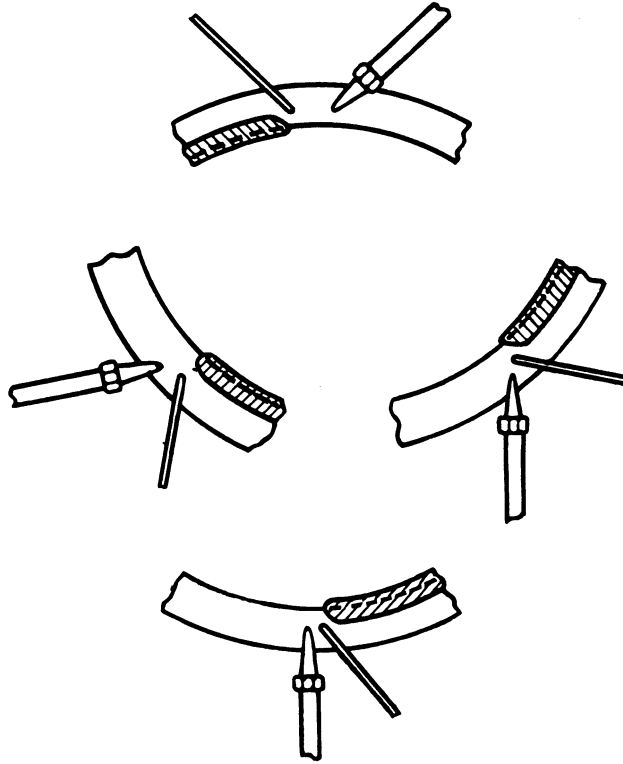

Sectional elevations.

Figure 19 — Multi-layer technique. Pipe horizontal

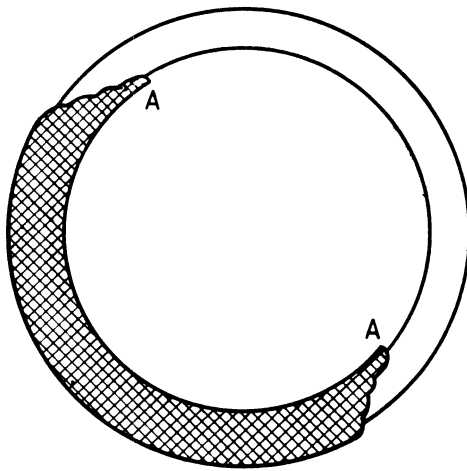

Figure 20 — Block-welding technique

Publications referred to

BS 1453, *Filler materials for gas welding.*

BS 1640, *Steel butt-welding pipe fittings for the petroleum industry — Part 3 Wrought carbon and ferritic alloy steel fittings.*

BS 1821, *Class I oxy-acetylene welding of ferritic steel pipework for carrying fluids²⁾.*

BS 2633, *Class I arc welding of ferritic steel pipework for carrying fluids²⁾.*

BS 2910, *Methods for the radiographic examination of fusion welded circumferential butt joints in steel pipes.*

BS 2971, *Specification for class II arc welding of carbon steel pipework for carrying fluids.*

BS 3059, *Specification for steel boiler and superheater tubes.*

BS 3059-1, *Low tensile carbon steel tubes without specified elevated temperature properties.*

BS 3059-2, *Carbon, alloy and austenitic stainless steel tubes with specified elevated temperature properties.*

BS 3601, *Specification for carbon steel pipes and tubes with specified room temperature properties for pressure purposes.*

BS 3602, *Specification for steel pipes and tubes for pressure purposes: carbon and carbon manganese steel with specified elevated temperature properties.*

BS 3602-1, *Seamless, electric resistance welded and induction welded tubes.*

BS 3602-2, *Longitudinally arc welded tubes.*

BS 3606, *Specification for steel tubes for heat exchangers.*

BS 3799, *Steel pipe fittings, screwed and socket-welding for the petroleum industry.*

BS 3923, *Methods for ultrasonic examination of welds.*

BS 3923-1, *Manual examination of fusion welds in ferritic steels.*

BS 4204, *Specification for flash welding of steel tubes for pressure applications²⁾.*

BS 4677, *Specification for arc welding of austenitic stainless steel pipework for carrying fluids²⁾.*

BS 4870, *Approval testing of welding procedures³⁾.*

BS 4870-1, *Fusion welding of steel.*

BS 4872, *Approval testing of welders when welding procedure approval is not required.*

BS 4872-1, *Fusion welding of steel.*

BS 1387, *Specification for screwed and socketed steel tubes and tubulars and for plain end steel tubes suitable for welding or for screwing to BS 21 pipe threads.*

BS EN 288-3, *Specification and approval of welding procedures for metallic materials. Welding procedure tests for the arc welding of steels.*

²⁾ Referred to in the foreword only.

³⁾ Withdrawn and superseded by BS EN 288-3.

BSI — British Standards Institution

BSI is the independent national body responsible for preparing British Standards. It presents the UK view on standards in Europe and at the international level. It is incorporated by Royal Charter.

Revisions

British Standards are updated by amendment or revision. Users of British Standards should make sure that they possess the latest amendments or editions.

It is the constant aim of BSI to improve the quality of our products and services. We would be grateful if anyone finding an inaccuracy or ambiguity while using this British Standard would inform the Secretary of the technical committee responsible, the identity of which can be found on the inside front cover. Tel: 020 8996 9000. Fax: 020 8996 7400.

BSI offers members an individual updating service called PLUS which ensures that subscribers automatically receive the latest editions of standards.

Buying standards

Orders for all BSI, international and foreign standards publications should be addressed to Customer Services. Tel: 020 8996 9001. Fax: 020 8996 7001.

In response to orders for international standards, it is BSI policy to supply the BSI implementation of those that have been published as British Standards, unless otherwise requested.

Information on standards

BSI provides a wide range of information on national, European and international standards through its Library and its Technical Help to Exporters Service. Various BSI electronic information services are also available which give details on all its products and services. Contact the Information Centre. Tel: 020 8996 7111. Fax: 020 8996 7048.

Subscribing members of BSI are kept up to date with standards developments and receive substantial discounts on the purchase price of standards. For details of these and other benefits contact Membership Administration. Tel: 020 8996 7002. Fax: 020 8996 7001.

Copyright

Copyright subsists in all BSI publications. BSI also holds the copyright, in the UK, of the publications of the international standardization bodies. Except as permitted under the Copyright, Designs and Patents Act 1988 no extract may be reproduced, stored in a retrieval system or transmitted in any form or by any means – electronic, photocopying, recording or otherwise – without prior written permission from BSI.

This does not preclude the free use, in the course of implementing the standard, of necessary details such as symbols, and size, type or grade designations. If these details are to be used for any other purpose than implementation then the prior written permission of BSI must be obtained.

If permission is granted, the terms may include royalty payments or a licensing agreement. Details and advice can be obtained from the Copyright Manager. Tel: 020 8996 7070.