



Specification for

Class I arc welding of ferritic steel pipework for carrying fluids

ICS 25.160.10

Committees responsible for this British Standard

The preparation of this British Standard was entrusted by the Welding Standards Committee (WEE/-) to Technical Committee WEE/21, upon which the following bodies were represented:

Associated Offices Technical Committee
 British Gas plc
 British Non-ferrous Metals Federation
 Electricity Supply Industry in England and Wales
 Engineering Equipment and Materials Users' Association
 Health and Safety Executive
 Heating and Ventilating Contractors' Association
 Institute of Refrigeration
 Institution of Gas Engineers
 Institution of Mechanical Engineers
 Joint Industry Board for Plumbing Mechanical Engineering Services in England and Wales
 National Association of Plumbing, Heating and Mechanical Services Contractors
 Power Generation Association (BEAMA Ltd.)
 Stainless Steel Fabricators' Association of Great Britain
 United Kingdom Atomic Energy Authority
 Water-tube Boilermakers' Association
 Welding Institute
 Welding Manufacturers' Association (BEAMA Ltd.)
 Coopted member

This British Standard, having been prepared under the direction of the Welding Standards Committee, was published under the authority of the Board of BSI and comes into effect on 29 May 1987

© BSI 05-1999

First published January 1956
 First revision October 1966
 Second revision May 1973
 Third revision May 1987

The following BSI references relate to the work on this standard:
 Committee reference WEE/21
 Draft for comment 85/73616 DC

ISBN 0 580 15917 5

Amendments issued since publication

Amd. No.	Date of issue	Comments
5798	February 1998	
6969	July 1992	
9800	February 1998	
10065	September 1998	Indicated by a sideline in the margin

Contents

	Page
Committees responsible	Inside front cover
Foreword	ii
<hr/>	
Section 1. General	
1 Scope	1
2 Information and requirements to be agreed and to be documented	1
3 Parent metal	2
4 Condition of pipes	2
5 Weld metal	2
6 Gases for shielding and purging	3
7 Equipment	3
8 Welding processes	3
9 Backing rings	4
10 Joint preparation	4
11 Proximity of welds	4
12 Fusion faces	5
13 Assembly for welding	5
14 Purging	6
15 Damage to parent metal by arc strikes	6
16 Inter-run cleaning	6
17 Cold pull	6
18 Pre-heating for cutting and welding	6
19 Change of pre-heating with welding process	7
20 Continuity of welding and pre-heating	7
21 Dressing of welds in ½ Cr ½ Mo ¼ V pipes	7
22 Post-weld heat treatment	9
23 Temperature measurement	12
24 Transition joints between dissimilar steels	12
<hr/>	
Section 2. Butt joints	
25 General	14
26 All types of butt joint	14
27 Gusseted bends	14
<hr/>	
Section 3. Branches and small bore connections	
28 General	18
29 Branches	18
<hr/>	
Section 4. Socket-welding fittings	
30 General	19
31 Socket joint details	19
<hr/>	
Section 5. Reinforcement of welded branch connections (compensation)	
32 General	20
33 Preparation and assembly	20
34 Welding procedure	20
<hr/>	
Section 6. Structural attachments	
35 General	21
36 Welding procedure	21

	Page
Section 7. Flanges	
37 General	22
38 Welding neck flanges	22
39 Plate flanges	22
<hr/>	
Section 8. Inspection	
40 Requirements for visual examination of completed welds	23
41 Non-destructive testing	23
42 Defect limitations	24
<hr/>	
Section 9. Rectification of defective welds	
43 Removal of defects	26
44 Preparation for re-welding	26
45 Re-welding	26
<hr/>	
Section 10. Welding procedure approval	
46 General	27
47 Attachments to thin pipes	27
48 Branch welds	27
<hr/>	
Section 11. Welder approval	
49 General	28
50 Attachments to thin pipes	28
<hr/>	
Appendix A Classes of operating conditions	29
Appendix B Grades of steel in British Standards and similar grades for pipe in ASTM and DIN standards	30
Appendix C Guidance on suitable types of weld metal	32
Appendix D Typical joint preparations	34
Appendix E Guidance on welding transition joints between ferritic steel and austenitic stainless steel	50
Appendix F Guidance on the use of methods of non-destructive testing	53
<hr/>	
Figure 1 — Permissible types of permanent backing ring	5
Figure 2 — Types of backing ring not permissible	5
Figure 3 — Permissible types of temporary steel backing ring	5
Figure 4 — Example of proximity of attachment weld	5
Figure 5 — Area (shaded) to be heated for the local treatment of branch connections	9
Figure 6 — Post-weld heat treatment heating and cooling rates for materials other than $\frac{1}{2}$ Cr $\frac{1}{2}$ Mo $\frac{1}{4}$ V and $2\frac{1}{4}$ Cr 1 Mo steels	13
Figure 7 — Segmental bends	16
Figure 8 — Cut-and-shut bend	17
Figure 9 — Socket joint details	19
Figure 10 — Welding neck flange	22
Figure 11 — Typical butt joint preparations for use with metal-arc welding, with backing ring for single or double root run	34
Figure 12 — Typical butt joint preparations for use with metal-arc welding, with backing ring where protrusion into the bore is not permissible	35
Figure 13 — Typical butt joint preparations for use with metal-arc welding, without backing ring	35

	Page
Figure 14 — Typical butt joint preparations for use with manual TIG welding, with or without filler wire	36
Figure 15 — Typical butt joint preparations for use with TIG welding for the root run, with or without filler wire, or with fusible insert	37
Figure 16 — Typical butt joint preparations using a narrow gap	39
Figure 17 — Typical preparation and assembly of set-on right angle branches without backing	40
Figure 18 — Typical preparation and assembly of set-on sloping branches without backing	41
Figure 19 — Typical preparation and assembly of set-in branches (access from inside pipe)	42
Figure 20 — Typical preparation and assembly of set-on right angle branches with temporary backing	43
Figure 21 — Typical preparation and assembly of set-on sloping branches with temporary backing	44
Figure 22 — Typical set-on connection	45
Figure 23 — Typical small bore connections	46
Figure 24 — Typical “face and back” welded-on flange	47
Figure 25 — Typical “bore and back” welded-on flange	47
Figure 26 — Typical “bore and back” welded-on flange for positional welding	48
Figure 27 — Typical “face and fillet” welded-on flange	48
Figure 28 — Typical “bore and fillet” welded-on flange	48
Figure 29 — Typical “bore and fillet” welded-on flange for positional welding	49
Figure 30 — Typical “slip on” welded-on flange	49
Figure 31 — Typical “slip on” hubbed welded-on flange	49
Figure 32 — Typical “face and fillet” hubbed welded-on flange	50
Table 1 — Parent metals	2
Table 2 — Methods of making initial root runs in butt joints	4
Table 3 — Material for steel backing rings	4
Table 4 — Pre-heating for thermal cutting	7
Table 5 — Pre-heating for welding	8
Table 6 — Post-weld heat treatment	11
Table 7 — Typical limits for bore difference and alignment for manual welding	15
Table 8 — Penetration of root bead	23
Table 9 — Defect limits	25
Table 10 — Classes of operating conditions	29
Table 11 — Grades of steel in British Standards	30
Table 12 — Grades in ASTM and DIN standards of similar weldability to British Standard grades of pipe	31
Table 13 — British Standards for electrodes and filler wires	32
Publications referred to	54

Foreword

This revision of this British Standard has been prepared under the direction of the Welding Standards Committee. It embodies the technical developments that have taken place since the 1973 edition which is withdrawn.

The relevant application standard, where it exists, should specify whether class I welding of pipework is required, but the factors to be taken into account in coming to such a conclusion are the operating conditions of the pipework, the degree of inspection and the acceptance requirements (see also Appendix A).

It is further recommended that carbon steels with a carbon content exceeding 0.25 % and all ferritic alloy steels, be welded in accordance with this standard irrespective of the operating conditions.

Purchasers ordering to this standard are advised to specify in their contracts that the manufacturer operates a quality system in compliance with the appropriate Part of BS EN ISO 9000 to assure themselves that pipework claimed to have been welded in accordance with BS 2633 consistently achieves the required level of quality.

The following are companion standards to this standard.

BS 1821, *Specification for class I oxy-acetylene welding of ferritic steel pipework for carrying fluids.*

BS 2640, *Specification for class II oxy-acetylene welding of carbon steel pipework for carrying fluids.*

BS 2971, *Specification for class II arc welding of carbon steel pipework for carrying fluids.*

BS 4204, *Specification for flash welding of steel tubes for pressure applications.*

BS 4677, *Specification for arc welding of austenitic stainless steel pipework for carrying fluids.*

Inspecting authority. For the purposes of this British Standard the term “inspecting authority” refers to that competent independent body or association which verifies compliance with this standard.

Contracting parties. For the purposes of this British Standard, the term “contracting parties” is intended to cover the purchaser, the manufacturer and the inspecting authority in any relevant combination according to the particular circumstances.

Pipe and tube. For the purposes of this British Standard the word “pipe”, alone or in combination, is used to mean “pipe” or “tube”, although these terms are often used for different categories of product by different industries.

Pipe dimensions. Unless otherwise qualified, for the purposes of this British Standard “pipe diameter” relates to the nominal value of the outside diameter and “pipe thickness” relates to the nominal value of the wall thickness specified in the standard to which the pipe is ordered.

At the time of publication of this British Standard, no corresponding international standard exists.

It has been assumed in the drafting of this British Standard that the execution of its provisions is entrusted to appropriately qualified and experienced people.

A British Standard does not purport to include all the necessary provisions of a contract. Users of British Standards are responsible for their correct application.

Compliance with a British Standard does not of itself confer immunity from legal obligations.

Summary of pages

This document comprises a front cover, an inside front cover, pages i to vi, pages 1 to 55 and a back cover.

This standard has been updated (see copyright date) and may have had amendments incorporated. This will be indicated in the amendment table on the inside front cover.

Section 1. General

1 Scope

This British Standard specifies requirements for both shop and site class I arc welding, using manual, semi-automatic, automatic and mechanized welding processes or combinations of these, of joints in ferritic steel pipework intended to carry fluids.

In addition to the definitive requirements, this standard also requires the items detailed in clause 2 to be documented. For compliance with this standard, both the definitive requirements and the documented items have to be satisfied.

NOTE The titles of the publications referred to in this standard are listed on page 54.

2 Information and requirements to be agreed and to be documented

2.1 Information to be supplied by the purchaser

The following information to be supplied by the purchaser at the contract stage shall be fully documented. Both the definitive requirements specified throughout the standard and the documented items shall be satisfied before a claim of compliance with the standard can be made and verified.

- a) The application standard to be used if any.
- b) Whether records of materials used during fabrication are required (see 3.2).
- c) Whether permanent backing rings are required (see 9.1).
- d) Whether all welds are to be heat-treated after welding and/or written heat treatment procedures are to be submitted (see 22.1.1).
- e) Whether completed welds are to be ground (see 40.1).
- f) Lower limits on bore protrusion when required (see 40.4).
- g) The percentage of each welder's production of butt joints to be subjected to radiographic and/or ultrasonic examination when more than 10% is required (see 41.1.2).
- h) Whether magnetic particle or liquid penetrant testing is required [see 41.4.1 b)].
- i) Alternative defect limitations when required (see 42.2).
- j) Whether welding procedure tests using pipe of specified diameter and thickness are required (see 46.2).
- k) Whether impact tests are required as part of the welding procedure approval (see 46.3).

2.2 Requirements to be agreed

The following items to be agreed between the contracting parties, which are specified in the clauses referred to, shall be fully documented. Both the definitive requirements specified throughout the standard and the following documented items shall be satisfied before a claim of compliance with the standard can be made and verified.

- a) The materials to be used for pipes and attachments (see 3.1).
- b) The precautions in inspection and welding procedure required when welding cast parts (see 3.3).
- c) The heat-treated condition in which pipework is to be put into service when there is no application standard (see 4.1).
- d) The precautions to be taken when design factors preclude the avoidance of certain circumstances relating to the proximity of welds (see 11.3).
- e) An alternative method of heating to those given in 22.5 a) and b) for heat treatment after welding [see 22.5 c)].
- f) The method of attaching thermocouples (see 23.4).
- g) The welding procedure to be used for transition joints between dissimilar steels (see clause 24).
- h) The service conditions for which gusseted bends are to be used (see 27.1).
- i) Details of joint design and fabrication when the branch angle is less than 60° (see 29.1).
- j) The method and amount of inspection for partial penetration welds on structural attachments (see 36.2).
- k) The use of radiographic and/or ultrasonic examination (see 41.1.1).
- l) The inspection and testing requirements for other than butt joints (see 41.1.3).
- m) The radiographic technique to be used (see 41.2).
- n) The use of a method other than magnetic particle testing to check the building-up of the base of a groove for making a repair weld [see 44.3 b)].
- o) The use of a joint preparation incorporating a wider root gap for making a repair weld [see 44.3 c)].

3 Parent metal

3.1 The parent metal for pipes (including those with a longitudinal or helical welded seam) and attachments shall be one of the types of steel listed in Table 1. The materials selected shall be agreed between the contracting parties, taking account of their suitability for the service conditions [see 2.2 a)].

NOTE Appendix B gives details of grades in British Standards for the types of steel listed in Table 1 and nearest similar grades in ASTM and DIN standards for pipe.

Table 1 — Parent metals

Type of steel
C and C-Mn (≤ 0.25 C)
C and C-Mn (> 0.25 C ≤ 0.4 C)
C-Mo
1 Cr $\frac{1}{2}$ Mo
$1\frac{1}{4}$ Cr $\frac{1}{2}$ Mo
1.25 Ni Cu Mo Nb
$\frac{1}{2}$ Cr $\frac{1}{2}$ Mo $\frac{1}{4}$ V
$2\frac{1}{4}$ Cr 1 Mo
5 Cr $\frac{1}{2}$ Mo
7 Cr $\frac{1}{2}$ Mo
9 Cr 1 Mo
9 Cr 1 Mo V Nb N
12 Cr Mo V (W) ^a
$3\frac{1}{2}$ Ni
9 Ni

^a This steel has a high hardenability accompanied by relatively low toughness in the untempered condition and therefore for thicknesses over 12.5 mm special precautions are necessary (see 18.3).

3.2 When required by the purchaser, the manufacturer shall maintain records of the materials used during fabrication [see 2.1 b)].

3.3 While the requirements of this standard apply also to the welding of cast parts, additional precautions in inspection and welding procedure that may be necessary to deal with the presence of non-metallic inclusions, alloy segregations or porosity, shall be subject to agreement between the contracting parties [see 2.2 b)]

4 Condition of pipes

4.1 Pipework shall be put into service in one of the following heat-treated conditions as stated in the application standard or as agreed between the contracting parties in the absence of such a standard [see 2.2 c)]:

- cold drawn or as rolled for C and C-Mn steels (≤ 0.25 C);
- hot formed;
- normalized (see 4.2);

d) normalized and tempered (see 4.3);

e) annealed (see 4.4).

4.2 Unless otherwise stated in the notes to Table 6, for pipes to be put into service in the normalized condition and which are in a normalized condition prior to welding, post-weld heat treatment shall be a local stress relief of the weld or a furnace stress relief of the pipework.

4.3 For pipes to be put into service in the normalized and tempered condition, the manufacturer shall either:

a) use pipes that are in a normalized condition prior to welding, in which case, following completion of welding, the pipework shall be tempered in an enclosed furnace;

or

b) unless otherwise stated in the notes to Table 6, use pipes that are in a normalized and tempered condition prior to welding, in which case, following completion of welding, the welds shall be given a local stress relief treatment or a furnace stress relief of the pipework.

4.4 For pipes in the annealed condition prior to welding, completed welds shall be given a local stress relief heat treatment.

NOTE Steel pipes of the $\frac{1}{2}$ Cr $\frac{1}{2}$ Mo $\frac{1}{4}$ V type are not normally supplied in the annealed condition since stress relieving alone will not put the material into its best condition for creep resistance.

The steel derives its creep strength from carbide precipitation brought about by tempering of the normalized structure. In this particular context the terms "tempering" and "stress relieving" are synonymous.

5 Weld metal

5.1 Mechanical properties

The mechanical properties of the weld metal shall be suitable for the design requirements of the pipework system.

NOTE In general, the requirements for yield or creep strength, as appropriate to the design conditions, should be at least equal to the minimum in the specification for the parent metal. For joints between dissimilar steels see clause 24.

5.2 Chemical composition

The chemical composition of the weld metal, including that from fusible inserts, shall be compatible with that of the parent material.

NOTE Guidance on suitable types of weld metal is given in Appendix C.

The use of hydrogen controlled weld metal shall be as given in 18.3.

5.3 Submerged-arc welding consumables

Submerged-arc welding conditions can have a significant effect on the chemical composition of the weld metal. The welding conditions, therefore, shall be controlled to ensure that the correct weld metal composition is consistently achieved.

5.4 Storage and handling

Electrodes, filler wires and rods, and fluxes shall be stored and handled in accordance with the manufacturer's recommendations so as to avoid damage or deterioration to them and to the containers in which they are transported.

Electrodes, filler wires and rods, and fluxes that show signs of damage or deterioration shall not be used.

6 Gases for shielding and purging

6.1 Shielding gases

Where appropriate gases or gas mixtures of the following quality shall be used.

- a) *Argon*, complying with BS EN 439.
- b) *Argon/oxygen mixtures*, consisting of argon, with up to 5 % added oxygen and complying with BS EN 439.
- c) *Argon/carbon dioxide mixtures*, consisting of argon, with up to 20 % added carbon dioxide, with or without up to 5 % oxygen and complying with BS EN 439.
- d) *Argon/hydrogen mixtures*, consisting of argon, with up to 5 % added hydrogen and complying with BS EN 439.
- e) *Helium*, complying with BS EN 439.
- f) *Other gases or gas mixtures*, that have been proved to be satisfactory as a result of procedure approval tests.

6.2 Gases for back purging

For purging the back of a weld during welding, argon, argon/hydrogen mixtures or helium as specified in 6.1 or one of the following gases shall be used.

- a) *Nitrogen*, complying with BS EN 439.
- b) *Nitrogen/hydrogen mixtures*, consisting of nitrogen with up to 5 % hydrogen and complying with BS EN 439.

NOTE 1 Certain gases are heavier than air and therefore precautions should be taken to ensure adequate ventilation and extraction for all welding processes.

NOTE 2 The use of shielding or back purging gases that contain hydrogen can increase the weld hydrogen level and consideration of this should be given when using Table 5 to determine the required preheat.

7 Equipment

Welding plant, instruments, cables and accessories shall comply with the appropriate Parts of BS 638. Their capacity shall be adequate for the welding procedure proposed and subsequently to be approved.

The installation, operation and maintenance shall be effected by competent persons in accordance with the appropriate safety recommendations. All electrical equipment used in connection with the welding operation shall be adequately earthed.

Adequate means of measuring current shall be available either as part of the welding plant or by the provision of a portable ammeter. In the case of semi-automatic, automatic and mechanized welding, means shall be provided for measuring the arc voltage since this may exert considerable influence on the form, composition and soundness (e.g. porosity) of the weld. When using a gas-shielded welding process, means of measuring the gas flow shall be provided.

Where necessary, staging and protection from the weather shall be provided to enable the welding operation to be performed properly.

8 Welding processes

8.1 Complete welds

Welds shall be made by one of the following welding processes or by a combination of those processes:

- manual metal-arc welding
- MIG welding
- metal active-gas welding
- TIG welding
- submerged-arc welding
- tubular cored arc welding with or without gas shielding

8.2 Root runs

Methods of making the initial root run in butt joints by the various welding processes shall be as given in Table 2.

Table 2 — Methods of making initial root runs in butt joints^a

Welding processes	Type of joint
Manual metal-arc welding MIG welding Metal active-gas welding Tubular cored arc welding with or without gas shielding	With temporary ^b or permanent (if permitted, see 9.1) backing ring or unbacked without purge
TIG welding: a) with fusible insert b) without fusible insert but using filler wire c) fusing root without using either fusible insert or filler wire	Backed or unbacked with or without purge
Submerged-arc welding	With temporary ^b or permanent (if permitted, see 9.1) backing ring

^a By agreement between the contracting parties joints in certain materials may be made with an oxy-acetylene root run without a backing ring (see BS 1821).
^b The use of temporary backing rings is dependent upon access for their removal on completion of the weld (see also clause 9).

9 Backing rings

9.1 Permanent steel backing rings

NOTE In general, for class I welding permanent backing rings are not recommended, especially for use with higher alloy materials. The interpretation of the results of ultrasonic examination of the weld root is impaired by the presence of a permanent backing ring. Depending on the fluid involved, there may also be a risk of crevice corrosion or a lowering of fatigue life.

When permanent backing rings are permitted by the application standard or are required by the purchaser [see 2.1 c)], the rings shall be one of the types shown in Figure 1. The gap between the outside diameter of the backing ring and the bore of the pipe end shall not exceed 0.5 mm.

Backing rings fitting tightly into machined recesses with square or sharp corners or of such a shape as to restrict longitudinal contraction (see Figure 2) shall not be used as they increase the tendency to basal crack formation.

When a machined backing ring is split to allow it to spring against the internal surface of the pipe, the gap between the ends of the split ring, when fitted, shall not exceed 1.5 mm.

Depending on the parent metal of the pipe, backing rings shall be made from pipe or strip selected as appropriate from Table 3.

Table 3 — Material for steel backing rings

Pipe material	Backing ring material (pipe or strip)
C and C-Mn 1 Cr ½ Mo 1¼ Cr ½ Mo 1.25 Ni Cu Mo Nb ½ Cr ½ Mo ¼ V 2¼ Cr 1 Mo	(a) C or C-Mn steel ≤ 0.25 C with sulphur and phosphorus contents ≤ 0.050 % each, or (b) a lower alloy steel selected from those listed, or (c) steel of chemical composition similar to that of pipe material
5 Cr ½ Mo	5 Cr ½ Mo
7 Cr ½ Mo	7 Cr ½ Mo or 5 Cr ½ Mo
9 Cr 1 Mo 9 Cr 1 Mo V Nb N	9 Cr 1 Mo, 9 Cr 1 Mo V Nb N or 7 Cr ½ Mo
12 Cr Mo V (W) 3½ Ni 9 Ni	Steel of chemical composition similar to that of pipe material

9.2 Temporary steel backing rings

Temporary steel backing rings (see Figure 3) shall be of material selected as appropriate from Table 3.

NOTE A high or segregated sulphur content in the backing ring may produce defects at or in the root run.

9.3 Temporary non-metal backing rings

Temporary non-metal backing rings shall be of non-combustible materials and shall be completely removed after completion of welding.

10 Joint preparation

Joint preparations shall be as shown in the approved welding procedure.

NOTE Typical joint preparations are given in Appendix D. The choice of joint preparation, including access, should take account of the method of non-destructive testing to be used.

11 Proximity of welds

11.1 The design of joints shall be such as to provide adequate access for the deposition of weld metal and for the application of any post-weld heat treatment to meet the requirements of this standard [see also 22.3.1 b) and 22.4.2 b)].

11.2 The toes of adjacent butt welds shall, whenever possible, be no closer than four times the nominal thickness of the pipe.

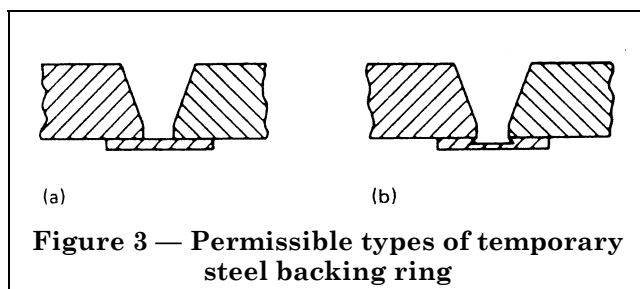
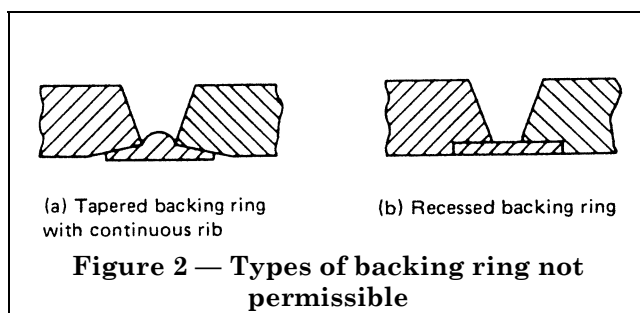
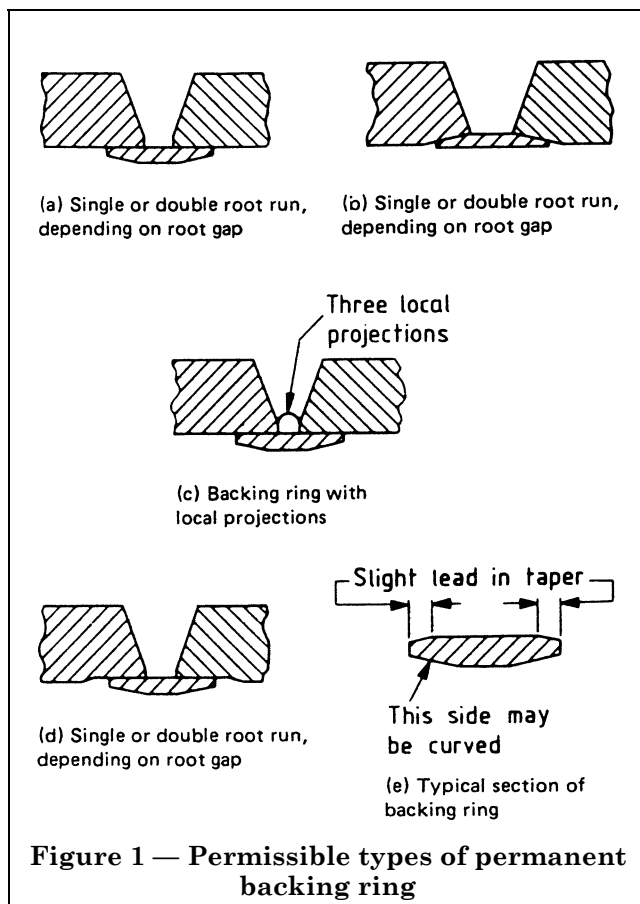

11.3 If design factors preclude the avoidance of the circumstances given in the following notes, then appropriate precautions shall be taken which shall be agreed between the contracting parties [see 2.2 d)].

NOTE 1 Joints where more than two welded seams meet should be avoided.

NOTE 2 Attachments of non-pressure parts by welds which cross existing main welds or for which the minimum nominal distance between the toe of the attachment weld and the toe of the existing main welds or branch welds (S) is less than the smaller of twice the thickness of the pressure part (t) or 40 mm, should be avoided (see Figure 4).

If such welds cannot be avoided, they should cross the main weld completely rather than stop abruptly near the main or branch weld in order to avoid stress concentrations in these areas. Non-destructive testing of main welds should be carried out before attachment welds which cross them are deposited.

11.4 All intersections of welds made in accordance with this standard shall be non-destructively tested (see section 8).

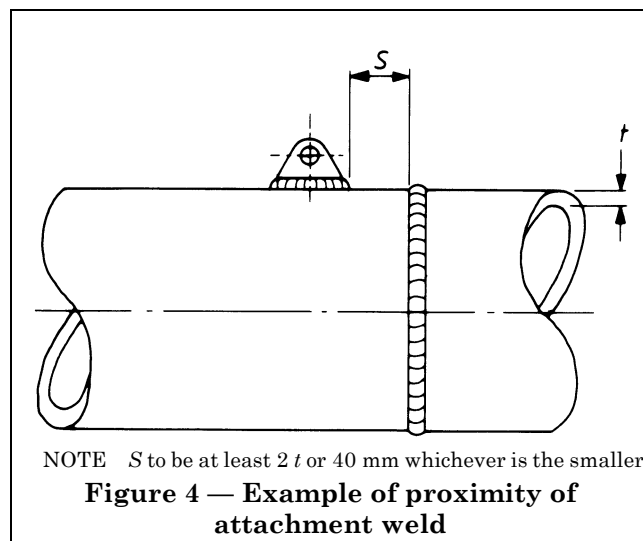

12 Fusion faces

The fusion faces and the adjacent material shall be free from moisture, scale, rust, paint, grease or other foreign matter immediately prior to welding.

NOTE Certain proprietary protective coatings are specially formulated with the intention that they should not interfere with subsequent welding. The use of such coatings is not excluded by the requirements of this clause, but if so required by the purchaser, the manufacturer should demonstrate their acceptability by means of specimen welds (see BS 6084).

13 Assembly for welding

To maintain the specified alignment (see 26.1) and gap, where used, during welding, the parts to be welded shall be securely held in position by mechanical means, welded-on bridge pieces, or tack welding.

NOTE The specified dimensions of the root gap are the dimensions after tack welding. It is appreciated that there may be difficulty in complying strictly with the specified requirements for the root gap. Slight modifications imposed by practical considerations may be permitted.

The pre-heating in accordance with clause 18 for the pipe material shall be applied and maintained during tack welding and the welding-on of bridge pieces or other attachments.

Hot setting to achieve alignment shall only be carried out under controlled conditions.

Electrodes or filler materials used for tack welds shall be of the same type and class, and of the same size, as those to be used for completing the first run of weld metal. Electrodes or filler materials used for welded-on bridge pieces shall be of a chemical composition compatible with that of the weld metal specified for the joint fill-up.

Particular attention shall be paid to the quality of tack welds or welded-on bridge pieces which shall be deposited by approved welders. The throat thickness of tack welds shall be similar to that of the initial root run. Where necessary, the extremities of these tack welds shall be dressed by grinding or chipping to facilitate proper fusion when they are incorporated in the root run. Tack welds not incorporated in the root run shall be removed, but any tack weld not complying with this standard shall be completely removed.

Where welded-on bridge pieces are used, the pipe surfaces shall not be left in a damaged condition after the bridge pieces are removed. All welded-on bridge pieces shall be removed and the welded area ground flush and crack detected before applying any post-weld heat treatment, which shall embrace the area occupied by the bridge pieces.

14 Purging

When back purging, air shall be removed in the vicinity of the weld by the admission of a sufficient volume of purging gas such that oxidation of the penetration bead is prevented.

15 Damage to parent metal by arc strikes

While arc strikes are to be avoided, all accidental arc strikes shall be ground smooth and crack detected. A piece of scrap plate clamped to the pipe near the weld shall be used for dabbing the electrode where such a procedure is necessary for removing slag from the tip or to facilitate the starting of the arc.

NOTE 1 It is recommended that electrode holders be of the fully insulated type.

NOTE 2 Stray arcing between the work and either the welding earth return lead or any part at earth potential can be avoided by a firm earth connection (see clause 7).

16 Inter-run cleaning

Each run of weld metal shall be clean before a further run is applied, particular attention being paid to the junctions between the weld metal and the fusion faces. Visible defects such as cracks, cavities and other deposition faults shall be removed before deposition of further weld metal.

17 Cold pull

Where the effects of thermal expansion in service are to be counteracted by "cold pull" during erection of the pipe assembly, the "cold pull" shall be maintained during pre-heating (where applicable), welding, any post-weld heat treatment and cooling. Before applying "cold pull" to a joint, all other joints in the pipe assembly shall have been welded, subjected to any post-weld heat treatment, inspected and accepted.

18 Pre-heating for cutting and welding

18.1 General

No thermal cutting, welding or tack welding shall be carried out when the temperature of the parent material within 75 mm of the joint or cut is less than the appropriate temperature given in Table 4 or Table 5. The temperature shall be confirmed on the heated face at a time, after removal of the heat source, related to parent metal thickness to allow for temperature equalization.

NOTE The time allowed for temperature equalization should be of the order of 2 min for each 25 mm of parent metal thickness.

18.2 Pre-heating for cutting

Pre-heating for thermal cutting shall be applied in accordance with Table 4, unless other procedures have been demonstrated by the contractor to be acceptable (see section 10).

18.3 Pre-heating for welding

Pre-heating for welding shall be applied in accordance with Table 5, unless welding procedures have proved that different conditions are acceptable (see section 10). For the purposes of Table 5 the material thickness shall be the greater component thickness within a distance of 75 mm from the root of the weld preparation. Pre-heating shall be applied at least to the area local to and including the weld preparation and the temperature shall be maintained during the deposition of weld metal (see also clauses 20 and 23).

Table 4 — Pre-heating for thermal cutting

Type of steel	Material thickness	Minimum pre-heating temperature
C and C-Mn (≤ 0.25 C) C and C-Mn (> 0.25 C ≤ 0.4 C)	mm All	$^{\circ}$ C 5
C-Mo 1 Cr $\frac{1}{2}$ Mo 1 $\frac{1}{4}$ Cr $\frac{1}{2}$ Mo	≤ 12.5 > 12.5	5 100
1.25 Ni Cu Mo Nb $\frac{1}{2}$ Cr $\frac{1}{2}$ Mo $\frac{1}{4}$ V 2 $\frac{1}{4}$ Cr 1 Mo 5 Cr $\frac{1}{2}$ Mo 7 Cr $\frac{1}{2}$ Mo 9 Cr 1 Mo	All	150
12 Cr Mo V(W) 9 Cr 1 Mo V Nb N	All	200
3 $\frac{1}{2}$ Ni 9 Ni	All	5

18.4 Methods

Pre-heating shall be applied by one of the following means, the choice being dependent on local conditions:

- gas rings, gas radiant panels or muffle furnaces;
- electric resistance heaters;
- induction heating;
- oxy-acetylene or other gas torches.

The procedure used shall ensure a satisfactory temperature distribution around and through the joint to be welded and shall not interfere with access for welding.

NOTE To check that the pre-heating temperature distribution through the pipe is satisfactory, particularly when thick material is involved and/or heating is from the outside only, it is recommended that temperature measurements be made at the root of the joint.

Where pre-heating is applied manually by gas torches, care shall be taken to ensure an even distribution of heat. Excessive local heating of the pipe surface shall be avoided.

19 Change of pre-heating with welding process

Where the welding process employed for root runs differs from that used for subsequent runs, the pre-heating (if any) applicable to each process shall be determined in accordance with Table 5. Any change in pre-heating temperature required shall be made after completion of the first process but before commencement of the second process.

20 Continuity of welding and pre-heating

Irrespective of the type of steel, root runs shall be made without interruption other than for the changing of electrodes or filler materials or to allow the welder to re-position himself. Welds made at site shall not be allowed to cool until the thickness of weld metal deposited exceeds one-third of the final weld thickness.

NOTE 1 Root runs made in the workshop may afterwards be allowed to cool provided that precautions are taken to ensure slow cooling (e.g. wrapping in a dry thermal insulating blanket).

When welding other than C and C-Mn steels (≤ 0.25 C) and an interruption is necessary, either the pre-heating temperature shall be maintained during interruption, or the joint shall be wrapped in dry thermal insulating blankets to ensure slow cooling. Before recommencing welding, pre-heat shall again be applied.

NOTE 2 It is strongly recommended that any interruption of welding should be avoided.

NOTE 3 To minimize the risk of hydrogen cracking, especially in higher alloy Cr-Mo steels and in thick material, on completion of welding, the joint should be wrapped in dry thermal insulating blankets to ensure slow cooling, unless post-weld heat treatment is applied immediately or pre-heating is maintained.

21 Dressing of welds in $\frac{1}{2}$ Cr $\frac{1}{2}$ Mo $\frac{1}{4}$ V pipes

Welds joining $\frac{1}{2}$ Cr $\frac{1}{2}$ Mo $\frac{1}{4}$ V pipes shall be dressed either hot or cold before stress relieving to a smooth contour, blending weld and parent metal, and the reinforcement shall be ground smooth to ensure the removal of all surface fissures and undercut.

Where dressing is by cold grinding, pre-heating shall be maintained for a minimum period of 2 h after the completion of welding and prior to cooling to room temperature.

Where the dressing is by hot grinding, the dressing shall be carried out immediately on completing the welding of the joint ensuring that the joint temperature does not fall below 150 $^{\circ}$ C.

Table 5 — Pre-heating for welding (see also 18.3)

Type of steel	Minimum pre-heating temperature for TIG welding of root runs		Hydrogen controlled weld metal (note 1)		Non-hydrogen controlled weld metal		
	Carbon steel root run		Matching root run, all diameters and thicknesses	Material thickness	Minimum pre-heating temperature	Material thickness	Minimum pre-heating temperature
	≤ 127 mm dia. and ≤ 12.5 mm thick	> 127 mm dia. or > 12.5 mm thick					
	°C	°C	°C	mm	°C	mm	°C
C and C-Mn, (≤ 0.25 C)	5	≤ 30 mm ^a : 5 > 30 mm ^a : 100	≤ 30 mm ^a : 5 > 30 mm ^a : 100	≤ 30 > 30	5 100	≤ 20 > 20	5 100
C and C-Mn, (> 0.25 C ≤ 0.4 C)	50	100	100	All	150	All	200
C-Mo	5	100	≤ 12.5 mm ^a : 20 > 12.5 mm ^a : 100	≤ 12.5 > 12.5	20 100	≤ 38 (note 5)	150
1 Cr ½ Mo 1¼ Cr ½ Mo	5	100	100	≤ 12.5 > 12.5	100 150 } (note 3)	≤ 12.5 > 12.5 ≤ 20 (note 5)	150 200
1.25 Ni Cu Mo Nb	50 (note 7)	100 (note 7)	100	≤ 12.5 > 12.5	100 150	Note 6	Note 6
½ Cr ½ Mo ¼ V	50	100	100	≤ 12.5 > 12.5	150 200 } (note 3)	Note 6	Note 6
2¼ Cr 1 Mo	50	100	100	≤ 12.5 > 12.5	150 200 } (note 3)	≤ 12.5 (note 5)	200
5 Cr ½ Mo 7 Cr ½ Mo 9 Cr 1 Mo	Note 2	Note 2	150	All	200 (note 3)	Note 6	Note 6
9 Cr 1 Mo V Nb N	Note 2	Note 2	100 (note 3)	All	200 (note 3)	Note 6	Note 6
12 Cr Mo V(W)	Note 2	Note 2	150	All	150 (note 4)	Note 6	Note 6
3½ Ni 9 Ni	Note 2	Note 2	100	All	150	Note 6	Note 6

NOTE 1 Hydrogen controlled weld metal as defined in BS EN 499 contains no more than 5, 10, or 15 mL of diffusible weld metal for type H5, H10 and H15 respectively.

NOTE 2 A carbon steel root run is not to be used.

NOTE 3 When TIG welding is used a lower pre-heating temperature may be applied provided it is proved to be satisfactory by procedure tests.

NOTE 4 A welding process with extra low hydrogen potential (less than 5 mL per 100 g of deposited weld metal) should be employed. If a high pre-heating temperature is used, e.g. 300 °C, then the joint should be cooled to between 100 °C and 150 °C to ensure full transformation before post-weld heat treatment is applied. Welding at a pre-heating temperature in the region of 150 °C to 200 °C will ensure that a high degree of transformation and some tempering will occur during welding and will assist in the removal of hydrogen from the joint.

NOTE 5 Above the maximum thickness stated hydrogen controlled weld metal only to be used.

NOTE 6 Hydrogen controlled weld metal only to be used.

NOTE 7 A C-Mo root run is to be treated as a carbon steel root run.

NOTE 8 Both 9 Cr 1 Mo and 9 Cr 1 Mo V Nb N are considered to be matching root run compositions.

^a Thickness.

Where the joint is required to be cooled to room temperature, either for cold dressing or after hot dressing and prior to stress relieving, it shall be cooled in accordance with 22.7.

22 Post-weld heat treatment

22.1 General

22.1.1 The condition of the pipes prior to fabrication and the final heat-treated condition of the pipework determine the post-weld heat treatment that the pipework and welds or welds only shall receive, which shall be in accordance with clause 4. If the purchaser requires all welds to be heat-treated, and/or written heat treatment procedures to be submitted, he shall state this in the enquiry and the order [see 2.1 d)].

NOTE It is advisable for the purchaser, in all cases, to inform the manufacturer of the use to which the pipework will be put. For example, where service conditions are conducive to stress corrosion cracking, or involve exposure to hydrogen at a pressure of 70 bar¹⁾ or higher and a temperature of over 400 °C, heat treatment may need to be carried out irrespective of pipe thickness.

22.1.2 Any post-weld heat treatment shall be as follows:

- as given in the following subclauses and Table 6; or
- as specified in the application standard; or
- as stated in the approved welding procedure.

NOTE The need for making welding procedure tests is explained in clause 47.

22.2 Butt joints and gusseted bends

Butt joints shall be heat-treated after the completion of all welding in accordance with clause 4. The temperature and time at temperature shall be as given in Table 6.

Where local post-weld heat treatment is used, the temperature gradient shall be such that the length of material on each side of the weld at a temperature exceeding half the heat treatment temperature is at least $2.5 \sqrt{rt}$ where r is the bore radius and t is the pipe thickness at the weld.

22.3 Branch connections

22.3.1 C and C-Mn steels (≤ 0.25 C). Post-weld heat treatment for welds connecting a branch to a main pipe each of which is C or C-Mn steel (≤ 0.25 C) shall be as given in Table 6 where:

- the nominal thickness of the thicker part is over 35 mm; or
- the distance (as required by design) from the toe of a branch weld to the toe of the weld on an adjacent branch or attachment is less than four times the thickness of the main pipe.

22.3.2 C and C-Mn (> 0.25 C ≤ 0.4 C) and alloy steels. Post-weld heat treatment for welds in which either the branch pipe or main pipe is of C or C-Mn steel (> 0.25 C ≤ 0.4 C) or alloy steel shall be in accordance with clause 4 using the values for temperature and time at temperature given in Table 6.

22.3.3 Treatment. It is preferred that post-weld heat treatment be carried out in a stationary industrial furnace, but when it is necessary to apply a local heat treatment, the temperature gradient shall be such that the length of material from each crotch at a temperature exceeding half the heat treatment temperature is at least:

- $2.5 \sqrt{r_m t_m}$ along the main pipe where r_m is the bore radius and t_m is the thickness of the main pipe; and
- $2.5 \sqrt{r_b t_b}$ along the branch pipe where r_b is the bore radius and t_b is the thickness of the branch pipe (see Figure 5).

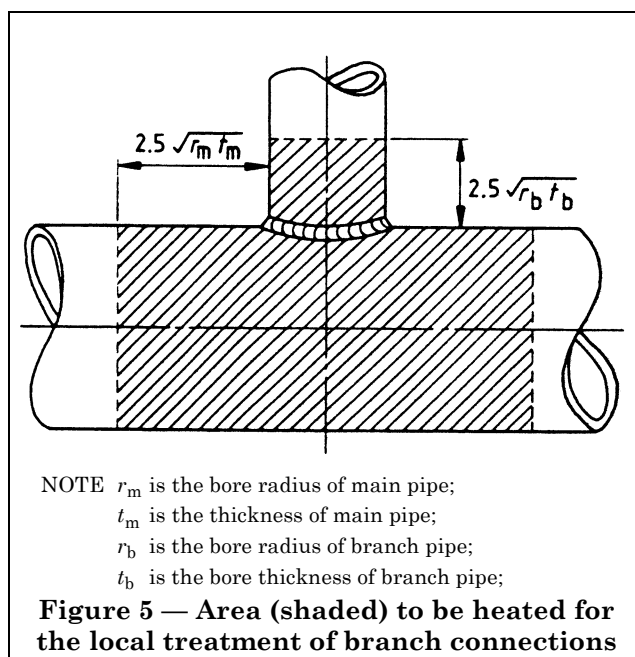

22.4 Plate flanges and attachments

22.4.1 General. Heat treatment shall be based on the nominal value of the sum of the individual throat thickness dimensions for each of the welds joining the flange or attachment to the pipe and not the thickness of the flange or attachment.

¹⁾ 1 bar = 10^5 N/m² = 100 kPa.

22.4.2 C and C-Mn steels (≤ 0.25 C). Post-weld heat treatment for welds connecting pipes to flanges or attachments each of which is C or C-Mn steel (≤ 0.25 C) shall be as given in Table 6 where:

- a) T is over 35 mm; or
- b) the distance from the toe of a flange weld to the toe of a weld on an adjacent attachment is less than $4 T$;

where T is the nominal value of the sum of the individual throat thickness dimensions for each of the welds joining the flange or attachment to the pipe.

22.4.3 C and C-Mn (> 0.25 C ≤ 0.4 C) and alloy steels. Post-weld heat treatment for welds connecting plate flanges or attachments, in which either the pipe or flange (attachment) is of C or C-Mn steel (> 0.25 C ≤ 0.4 C) or alloy steel, shall be in accordance with clause 4 using the values for the temperature and time at temperature given in Table 6.

22.4.4 Treatment. It is preferred that post-weld heat treatment be carried out in a stationary industrial furnace, but when local heat treatment of plate flanges or attachments is necessary, the whole of the flange or attachment shall be heated and the temperature gradient along the pipe shall be such that the length of material adjacent to the weld at a temperature exceeding half the heat treatment temperature is at least $2.5 \sqrt{rT}$, where r is the bore radius and T is the nominal value of the sum of the individual throat thickness dimensions for each of the welds joining the flange or attachment to the pipe.

NOTE To eliminate heat treatment on site work it is recommended that welded attachments should not be made direct to the pipe. Instead, intermediate plate or plates should be welded to the pipe in the shop, applying heat treatment where necessary, and the attachments welded to the intermediate plates at site.

22.5 Methods of heating

Heat treatment shall be carried out by one of the following methods, ensuring that the minimum stipulated temperature is achieved through the thickness of the pipes.

- a) Heating in a stationary industrial furnace.
- b) Local heating.
 - 1) Portable muffle furnace.
 - 2) Induction coils.
 - 3) Resistance heaters. The method of securing resistance heating elements around the joint shall be capable of holding the elements securely in contact with the pipework throughout the heat treatment cycle. Any fixing, e.g. galvanized wire, likely to be injurious to the joint shall not be used.

c) By agreement between the contracting parties, an alternative method of heating which precludes the use of thermocouples and has a heating rate in excess of that given in 22.6, provided that the reproducibility of the technique can be demonstrated and it can be shown that the method is metallurgically acceptable for the steel involved [see 2.2 e)].

Manually-operated gas torches shall not be used.

22.6 Heating rate

22.6.1 General. When a stationary furnace is used, its temperature shall not exceed 400 °C at the time the pipework is inserted.

22.6.2 Other than $\frac{1}{2}$ Cr $\frac{1}{2}$ Mo $\frac{1}{4}$ V, $2\frac{1}{4}$ Cr 1 Mo, 1.25 Ni Cu Mo Nb and 9 Cr 1 Mo V Nb N steels.

Irrespective of the method of heating, parts shall be heated to the appropriate temperature above 400 °C at a rate not exceeding the following.

For pipes of thickness up to and including 25 mm:

$$220 \text{ °C/h}$$

For pipes of thickness t over 25 mm:

$$\frac{5500}{t} \text{ °C/h, or}$$

55 °C/h, whichever is the greater.

NOTE These requirements are given in graphical form in Figure 6.

22.6.3 $\frac{1}{2}$ Cr $\frac{1}{2}$ Mo $\frac{1}{4}$ V, $2\frac{1}{4}$ Cr 1 Mo, 1.25 Ni Cu Mo Nb and 9 Cr 1 Mo V Nb N steels. Irrespective of the method of heating, parts shall be heated to the appropriate temperature above 400 °C at a rate not exceeding the following.

For pipes up to and including 127 mm diameter and up to and including 12.5 mm thick: 200 °C/h

For pipes over 127 mm diameter or thickness t over 12.5 mm:

$$100 \text{ °C/h, or}$$

$$\frac{6250}{t} \text{ °C/h, whichever is the lower.}$$

22.7 Cooling after heat treatment

22.7.1 General. Parts shall be allowed to cool down to 400 °C at the appropriate rate specified in 22.7.2 or 22.7.3.

NOTE Below 400 °C the parts may be cooled in still air.

Table 6 — Post-weld heat treatment (see also 22.1.1)

Type of steel	Soaking temperature °C	Minimum time at temperature (minutes per millimetre of thickness)	
		Heat treatment in furnace (pipework and welds)	Heat treatment (welds only)
C and C-Mn (≤ 0.25 C)	580 to 620 (note 1)	2.5 (minimum of 30 minutes)	2.5 (minimum of 30 minutes)
C and C-Mn (> 0.25 C ≤ 0.4 C)	630 to 670	2.5 (minimum of 30 minutes)	2.5 (minimum of 30 minutes)
C-Mo	630 to 670 (note 2)	2.5 (minimum of 60 minutes)	2.5 (minimum of 60 minutes)
1 Cr $\frac{1}{2}$ Mo 1 $\frac{1}{4}$ Cr $\frac{1}{2}$ Mo	630 to 670 (note 2)	5 (minimum of 120 minutes)	2.5 (minimum of 30 minutes)
1.25 Ni Cu Mo Nb	550 to 590 (note 8)	2.5 (minimum of 60 minutes)	2.5 (minimum of 60 minutes)
$\frac{1}{2}$ Cr $\frac{1}{2}$ Mo $\frac{1}{4}$ V	680 to 720	180 minutes irrespective of thickness (note 4)	2.5 (minimum of 180 minutes) (note 4)
2 $\frac{1}{4}$ Cr 1 Mo	680 to 720 (notes 2 and 3)	180 minutes irrespective of thickness (note 4)	2.5 (minimum of 60 minutes) (note 4)
	710 to 750 (notes 2 and 5)	5 (minimum of 120 minutes)	2.5 (minimum of 60 minutes)
5 Cr $\frac{1}{2}$ Mo 7 Cr $\frac{1}{2}$ Mo 9 Cr 1 Mo	710 to 750	5 (minimum of 120 minutes)	2.5 (minimum of 120 minutes)
9 Cr 1 Mo V Nb N	730 to 780	5 (minimum of 120 minutes) (note 4)	2.5 (minimum of 60 minutes) (note 4)
12 Cr Mo V(W) (note 6)	720 to 760	180 minutes irrespective of thickness	2.5 (minimum of 60 minutes)
3 $\frac{1}{2}$ Ni	580 to 620 (note 7)	2.5 (minimum of 60 minutes)	2.5 (minimum of 60 minutes)
9 Ni	Post-weld heat treatment not required		
NOTE 1 Post-weld heat treatment is not required for thicknesses up to and including 35 mm for service temperatures above 0 °C (see also 22.1.1).			
NOTE 2 Post-weld heat treatment is not required provided the design requirements and all the following criteria are satisfied (see also 22.1.1):			
a) the pipe material has 0.15 C maximum and 3 Cr maximum;			
b) the pipe is up to and including 127 mm diameter and up to and including 12.5 mm thick;			
c) any fillet welds have a throat thickness of 12 mm maximum;			
d) welding procedure tests have been satisfactorily carried out.			
NOTE 3 For optimum creep properties.			
NOTE 4 For pipes up to and including 127 mm diameter and up to and including 12.5 mm thick this time may be 30 minutes minimum.			
NOTE 5 For softening welded joints where optimum creep properties are not required.			
NOTE 6 For thicknesses over 12.5 mm, after welding but before post-weld heat treatment, ensure that the joint is cooled to between 100 °C and 150 °C to produce full transformation.			
NOTE 7 When Ni Cr Fe weld metal is used, post-weld heat treatment is not required for pipes thinner than 15 mm for service temperatures above - 105 °C (see also 22.1.1).			
If the Ni content of the weld metal exceeds 3 %, post-weld heat treatment is not required for pipes thinner than 20 mm for service temperatures above - 75 °C.			
NOTE 8 The maximum temperature should be limited to 30 °C below the tempering temperature of the original materials.			

22.7.2 Other than $\frac{1}{2}$ Cr $\frac{1}{2}$ Mo $\frac{1}{4}$ V, $2\frac{1}{4}$ Cr 1 Mo, 1.25 Ni Cu Mo Nb and 9 Cr 1 Mo V Nb N steels. Parts shall be allowed to cool at a rate not exceeding the following.

For pipes of thickness up to and including 25 mm:

275 °C/h

For pipes of thickness t over 25 mm:

$$\frac{6875}{t} \text{ °C/h, or}$$

55 °C/h, whichever is the greater.

NOTE These requirements are given in graphical form in Figure 6.

22.7.3 $\frac{1}{2}$ Cr $\frac{1}{2}$ Mo $\frac{1}{4}$ V, $2\frac{1}{4}$ Cr 1 Mo, 1.25 Ni Cu Mo Nb and 9 Cr 1 Mo V Nb N steels. Parts shall be allowed to cool at a rate not exceeding the following.

For pipes up to and including 127 mm diameter and up to and including 12.5 mm thick: 250 °C/h

For pipes over 127 mm diameter or over 12.5 mm thick: 50 °C/h.

23 Temperature measurement

23.1 General

Pre-heating, interpass and post-weld heat treatment temperatures shall be checked during the period of their application and all post-weld heat treatment conditions shall be recorded.

NOTE When methods in accordance with 22.5 c) are used, it may be necessary to undertake hardness surveys to check that the treatment has been applied effectively.

23.2 Pre-heating and interpass temperature

Temperature indicating crayons or paints, thermometers, thermocouples or pyrometers shall be used to check pre-heating and interpass temperatures.

NOTE Temperature indicating crayons or paints will not indicate by how much the minimum temperature is exceeded. Some types will not show, once the temperature has been reached, that this temperature is being maintained. In these cases the crayon or paint has to be re-applied if continued temperature observations are to be made.

When thermocouples are used, they shall be located in positions within 40 mm from the outside edge of the fusion faces.

23.3 Post-weld heat treatment temperature

Thermocouples shall be used for recording post-weld heat treatment temperatures except when the method of heating precludes their use [see 22.5 c)]. They shall be disposed so as to give a true measure of the joint temperature and where local post-weld heat treatment is used they shall be located so as to ensure that a band at least $1.5 t$ wide on each side of the weld centre-line is at the soaking temperature, where t is the pipe thickness.

NOTE To achieve this it is recommended that the heater width should be at least $5 t$.

23.4 Thermocouple attachment

Thermocouples shall be in metallic contact with the parts being heated and attached by a method agreed between the contracting parties, e.g. capacitor discharge welding [see 2.2 f)].

23.5 Thermocouple junctions

Thermocouple junctions and wires shall be protected from flame impingement. To prevent direct radiation from the heating elements on the hot junction when electrical resistance heating is used, thermocouples shall be covered with thermal insulation.

23.6 Instruments

The instruments for measuring and recording pre-heating and post-weld heat treatment temperatures shall be in accordance with BS EN 30012-1.

24 Transition joints between dissimilar steels

Each case of welding dissimilar steels shall be considered separately in relation to the conditions pertaining to the joint. The welding procedure to be used shall be the subject of agreement between the contracting parties [see 2.2 g)].

NOTE 1 The following details are given as guidance in determining the welding procedure for joining dissimilar ferritic steels.

- Pre-heat for higher alloy material.
- Use weld metal as for lower alloy material or an intermediate grade; alternatively use a high nickel alloy weld metal when 5, 7 or 9 Cr Mo or 12 Cr Mo V(W) material is involved (see Appendix C).

For dissimilar metal joints involving 9 Cr 1 Mo V Nb N steel, the use of 9 Cr 1 Mo weld metal may be necessary.

For dissimilar metal joints involving 12 Cr Mo V(W) steel (see the footnote to Table 1) the use of 12 Cr Mo V(W) weld metal may be necessary particularly when using manual metal-arc welding.

- The choice of post-weld heat treatment temperature is essentially a compromise. In general, heat treatment is applied as for the higher alloy material on the grounds that over tempering of the lower alloy material is preferable to under tempering of the higher alloy material. However, when creep properties are important, the effect of the higher tempering temperature should be assessed and, if necessary, the heat treatment should be for the lower alloy material using the highest temperature allowed in the range for that material. When there are differing times at temperature, the longer time should be used.

NOTE 2 Guidance on welding joints between ferritic steel and austenitic stainless steel, is given in Appendix E.

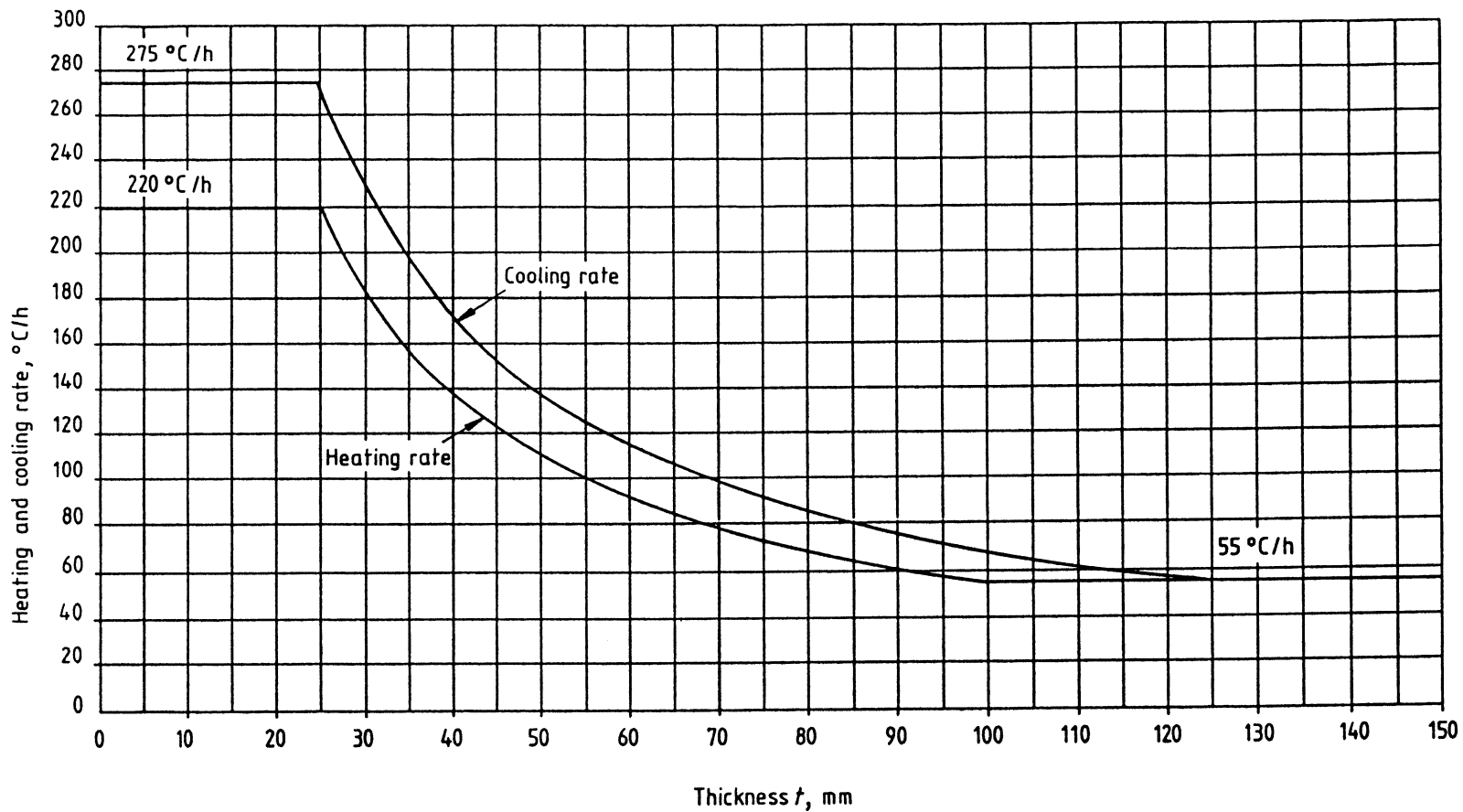

Figure 6 — Post-weld heat treatment heating and cooling rates for materials other than $\frac{1}{2}$ Cr $\frac{1}{2}$ Mo $\frac{1}{4}$ V, $2\frac{1}{4}$ Cr 1 Mo, 1.25 Ni Cu Mo Nb and 9 Cr 1 Mo V Nb N steels

Section 2. Butt joints

25 General

Section 1 of this standard details the basic procedure requirements with which all welded joints between pipes and fittings shall comply. These basic requirements are supplemented by the specific requirements detailed in this section 2. Both section 1 and section 2 of this standard shall be applied in determining the full procedure requirements.

26 All types of butt joint

26.1 Matching of bores

The welding of pipe²⁾ joints in accordance with this standard shall include the matching by the welding contractor of the pipe ends at each joint, if necessary.

NOTE 1 The bores of the ends of adjacent pipes should preferably match exactly. Typical acceptable limits for bore difference and alignment for manual welding are given in Table 7. For mechanized welding closer limits may be necessary.

Matching shall be effected by selection, drifting, machining, swaging or by the use of a suitable expander. When hot drifting or expanding is used, the temperature limitations given in a) to d) shall be applied. Temperatures shall be checked by one of the methods given in 23.2.

a) C and C-Mn (≤ 0.25 C), C-Mo, 1 Cr $\frac{1}{2}$ Mo and $1\frac{1}{4}$ Cr $\frac{1}{2}$ Mo steels. Hot drifting or expanding shall be carried out within a temperature range of either:

- 1) 900 °C to 975 °C; or
- 2) 450 °C to 650 °C.

b) C and C-Mn (> 0.25 C ≤ 0.4 C), 1.25 Ni Cu Mo Nb, $2\frac{1}{4}$ Cr 1 Mo and $\frac{1}{2}$ Cr $\frac{1}{2}$ Mo $\frac{1}{4}$ V steels. Hot drifting or expanding shall be carried out within a temperature range of either:

- 1) 950 °C to 1 100 °C, after which the pipes shall be normalized before welding in accordance with the material specification and tempered in accordance with 4.2 and 4.3, either before welding or as part of any post-weld heat treatment; or
- 2) 500 °C to 690 °C, after which normalizing is not necessary.

c) 5 Cr $\frac{1}{2}$ Mo, 7 Cr $\frac{1}{2}$ Mo, 9 Cr 1 Mo, 9 Cr 1 Mo V Nb N and 12 Cr Mo V (W) steels. Hot drifting or expanding shall be carried out within a temperature range of either:

- 1) 950 °C to 1 100 °C, after which the pipes shall be normalized before welding in accordance with the material specification and tempered in accordance with 4.2 and 4.3, either before welding or as part of any post-weld heat treatment; or

2) 550 °C to 720 °C, after which normalizing is not necessary.

d) $3\frac{1}{2}$ Ni and 9 Ni steels. Hot drifting or expanding shall be carried out within a temperature range of 950 °C to 1 100 °C, after which the pipes shall be normalized before welding in accordance with the material specification followed by tempering at 590 °C to 620 °C, being held at this temperature for 1 h minimum.

Wherever the thickness is reduced by drifting, machining, swaging or expanding, the thickness at every point in the circumference clear of the weld preparation shall be not less than the design thickness for the particular pipe. Any machining on the inside of the pipe shall run out smoothly into the bore at a taper not steeper than 1 in 4.

NOTE 2 If the maximum permissible amount of machining is insufficient to match the ends, drifting should be employed, but a combination of drifting or expanding with machining within the permitted limits may also be used.

NOTE 3 For some applications, in order to obtain the necessary bore alignment, building-up of the inside of the pipe end with weld metal is a recognized practice in which case the requirements of the relevant application standard should be followed.

26.2 Preparation of pipe ends

The ends shall be prepared by machining, grinding or machine gas cutting, or by manual flame cutting with subsequent filing or grinding. (See clause 18 for pre-heating requirements.)

NOTE Typical joint preparations for pipe ends are shown in D.1 (see also clause 10).

The joint preparation shall be concentric with the bore of the pipe within the tolerance limits for the root face.

For pipes that are intended to be in axial alignment, the plane of the ends shall be square with the axis of the pipe. For pipes that are intentionally out of axial alignment, the plane of the joint shall bisect the angle between adjacent pipes.

27 Gusseted bends

27.1 General

The service conditions for which gusseted bends are to be used shall be the subject of agreement between the contracting parties except where an application standard permits the use of such bends [see 2.2 h)].

NOTE Gusseted bends are of the following types.

- a) *Segmental*: separate pieces of pipe cut at an angle and welded together.
- b) *Cut-and-shut*: wedge shaped pieces cut from one side of a pipe, the pipe pulled round until the cut edges come to the correct welding position and then welded.

²⁾ In this section the term "pipe" is intended to cover pipes and fittings, e.g. welding neck flanges, forged tees, welding elbows.

Table 7 — Typical limits for bore difference and alignment for manual welding

Bore		Processes other than TIG welding		TIG welding, close butt welds		TIG welding with root gap
Over	Up to and including	With backing ring	Without backing ring	With fusible insert or without filler wire	With filler wire	
Maximum difference in bore (rounded to the nearest 0.5 mm)						
mm	mm	mm	mm	mm	mm	mm
—	100	0.5	1.0	0.5	1.0	1.0
100	300	0.5	1.5	0.5	1.0	1.5
300	—	1.0	2.5	—	1.5	2.5
Maximum out of alignment at the bore (rounded to nearest 0.5 mm)						
—	100	0.5	1.0	0.5	1.0	1.0
100	300	0.5	1.5	0.5	1.0	1.5
300	—	1.0	1.5	—	1.0	1.5

27.2 Preparation

27.2.1 General. The preparation of any gusset for any gusseted bend shall be done by cutting the pipe end to the correct angle followed by the weld preparation as specified in **26.2**.

To prepare the gussets for welding, all spatter, oxide and ragged edges shall be removed from the prepared edge and the bore of the pipes, the correct gap shall be set and the gussets tacked in position.

27.2.2 Segmental bends. The planes of the ends of the separate pieces of pipe prepared for welding to form a segmental bend shall all be inclined at the same angle to the axis of the piece.

The width of a segment at the throat of a bend measured at the outside diameter of the pipe shall be not less than 16.5 mm. For right angle bends of radius equal to the bore of the pipe, the dimensions of the segments shall be as shown in Figure 7, with only two cuts being necessary for pipe not exceeding 88.9 mm outside diameter.

NOTE Bends over 406.4 mm outside diameter may be difficult to produce as segmental bends, that is by preparing and assembling as separate segments of pipe. In such cases it is permissible first to prepare, close and tack weld as a cut-and-shut bend, and thereafter to complete the weld preparation by gouging the back of the bend in line with the extremities of the weld formed by the cut-and-shut method and so produce a continuous weld preparation as in a segmental bend.

27.2.3 Cut-and-shut bends. A cut-and-shut bend shall have the angle of cut equally disposed about a line at right angles to the axis of the pipe (see Figure 8). The change of angle of the centre-line at each cut shall not exceed approximately 30° and the width of the segment at the throat of the bend measured at the outside diameter of the pipe shall be not less than 16.5 mm as shown in Figure 8.

27.3 Welding procedure

All welds in a segmental bend shall be treated as butt welds and the requirements of clauses **13** and **25** and **26.2** shall apply. The welds shall be sound and shall penetrate at all points.

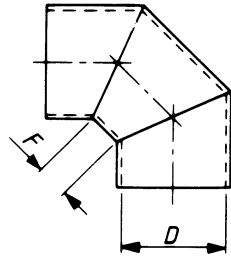

2 cuts, 1D radius

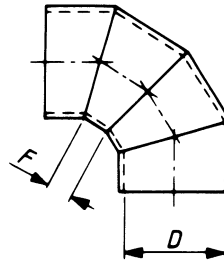

3 cuts, 1D radius

Inside diameter, D	Outside diameter	F
mm	mm	mm
50	60.3	16.5
65	76.1	22.5
75	88.9	25.0

Inside diameter, D	Outside diameter	F
mm	mm	mm
90	101.6	21.0
100	114.3	23.0
115	127.0	28.0
125	139.7	29.5
150	165.1	36.0
150	168.3	35.5
180	193.7	44.5
200	219.1	48.5
230	244.5	57.5
250	273.0	61.0
300	323.9	74.0
—	355.6	95.0
—	406.4	109.0

Figure 7 — Segmental bends

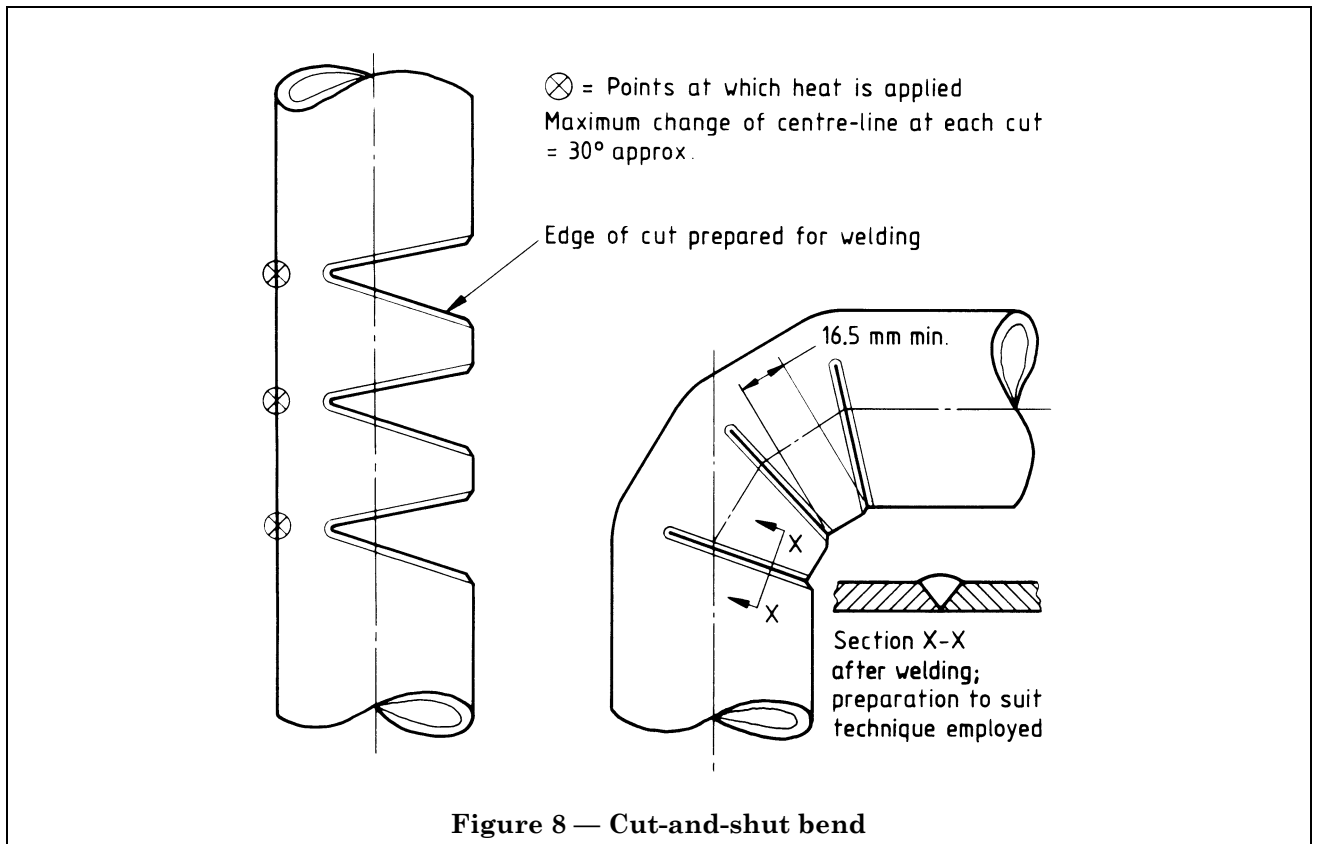

Section 3. Branches and small bore connections

28 General

Section 1 of this standard details the basic procedure requirements with which all welded joints between pipes and fittings shall comply. For branches or small bore connections that are made from pipe, tube or bar, the basic requirements are supplemented by the specific requirements detailed in this section 3. Both section 1 and section 3 of this standard shall be applied in determining the full procedure requirements.

NOTE 1 It is preferable that branches and small bore connections be welded at the works.

NOTE 2 When the bore of the branch is 50 mm or less, the guidance given in D.3 should be taken into account. (See clause 3 regarding parent metal and clause 5 on weld metal.)

29 Branches

29.1 Angle of branch

In view of the additional difficulty involved in making a satisfactory joint at the intersection of two pipes not at right angles, for branch pipes sloping away from a main, a right angle branch and a bend to give the required slope shall be used whenever possible.

Where a sloping branch has to be connected directly to the main, the angle between the centre-line of the main and that of the branch shall whenever possible be not less than 60°. Where the angle is unavoidably less than 60°, details of joint design and fabrication shall be agreed between the contracting parties [see 2.2 i)].

NOTE The difficulty of making a weld at the acute crotch position might make special precautions necessary to ensure a sound weld at that position.

29.2 Spacing of branches

Spacing of branches on the main pipe and the lengths of flanged branches shall be such that there is adequate access for satisfactory welding (see also clause 11).

29.3 Joint preparation

Branch connections and branch openings in the main pipe shall be cut by machining or thermal cutting. To remove any roughness the cut edges shall then be dressed by chipping, filing or grinding. (See clause 18 and Table 4 regarding the necessity to pre-heat for thermal cutting.)

NOTE Typical edge shapes are given in D.2 (see also clause 10).

29.4 Welding procedure

29.4.1 Gap. The gap, where specified, shall be maintained during deposition of the first run (see clause 13).

29.4.2 Internal root runs. When, in order to satisfy the requirements of section 9, it is necessary to apply an internal root run, access for the manual metal-arc welding of such an internal weld shall be considered possible:

- a) where the main is 450 mm bore or larger, irrespective of branch length; or
- b) where the main is less than 450 mm bore, and the branch length (face of branch to flank of joint) does not exceed the bore of the branch.

NOTE Using other welding processes it may be possible to weld in the bore of branches that have a length greater than that given in b).

Section 4. Socket-welding fittings

30 General

Section 1 of this standard details the basic procedure requirements with which all welded joints between pipes and fittings shall comply. These basic requirements are supplemented by the specific requirements detailed in this section 4. Both section 1 and section 4 of this standard shall be applied in determining the full procedure requirements.

31 Socket joint details

Forged socket-welding fittings shall be used within the limitations in the appropriate application standard and shall comply with BS 3799.

NOTE 1 A socket joint is formed when the end of a pipe enters the socket end of a socket-welding fitting and the pipe and socket are joined by means of a fillet weld. Socket joints should not be used where corrosion resistance is important. Socket-welding fittings may be machined from bar of suitable composition and quality.

Preparation and assembly of the joint for welding shall be such as to ensure that the pipe end is axially square to the base of the fitting and that there is a gap of approximately 1.5 mm between the pipe end and the base of the fitting (see Figure 9). To achieve this gap, the pipe end shall first be fully inserted and the outside surface of the pipe marked in line with the end face of the socket. The pipe shall then be withdrawn approximately 1.5 mm before welding.

NOTE 2 It is to be expected that the gap will have reduced after welding.

The diametral clearance between the outside diameter of the pipe and the bore of the fitting shall not exceed 1.0 mm.

The fillet weld leg lengths for socket joints shall be at least t by $1.25 t$ where t is the nominal pipe thickness (see Figure 9). For pipe of nominal thickness 3 mm or less, care shall be taken so that there is no over-heating or burn-through of the pipe (see clauses 47 and 50).

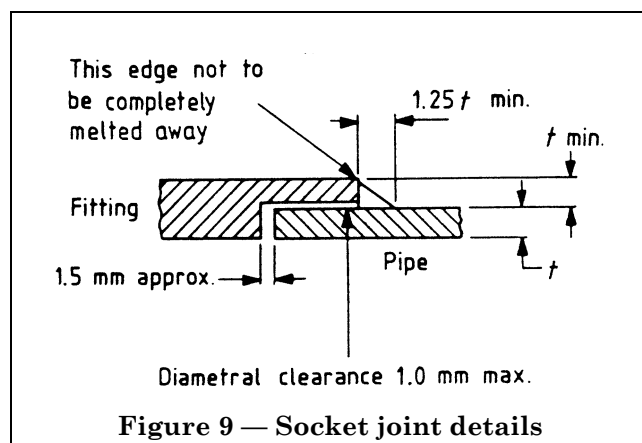

Section 5. Reinforcement of welded branch connections (compensation)

32 General

Section 1 of this standard details the basic procedure requirements with which all welded joints between pipes and fittings shall comply. These basic requirements are supplemented by the specific requirements detailed in this section 5. Both section 1 and section 5 of this standard shall be applied in determining the full procedure requirements.

NOTE The need to fit reinforcement to a branch connection should be determined by reference to the appropriate application standard. Gusset plates or stays should not be used as a method of reinforcement.

The preparation, assembly and welding of reinforcements shall comply with the procedure requirements applicable to the type of steel involved and shall be in accordance with the relevant clauses of this standard.

33 Preparation and assembly

When the reinforcement is thermally cut to shape, the cut edges shall be dressed by filing, grinding or machining. Pre-heating for thermal cutting shall be applied in accordance with clause 18.

The reinforcement shall be assembled and securely held in position on the main and/or branch by tack welds. The pre-heating requirements given in clause 18 for the pipe material shall be applied and maintained during tack welding. Tack welds shall be of sound quality. Any tack weld found to be cracked shall be removed completely and replaced by a tack weld of sound quality (see also clause 13).

34 Welding procedure

The pre-heating requirements given in clause 18 for the pipe material shall be applied and the temperature maintained during the entire welding operation.

Electrodes or filler materials shall be suitable for welding the pipe material to which the reinforcement is attached.

The procedure shall be such that complete fusion between the weld metal, pipe and reinforcement will be achieved.

Section 6. Structural attachments

35 General

Section 1 of this standard details the basic procedure requirements with which all welded joints between pipes and fittings shall comply. These basic requirements are supplemented by the specific requirements detailed in this section 6. Both section 1 and section 6 of this standard shall be applied in determining the full procedure requirements.

Attachments to pressure parts shall comply with this section.

NOTE For the design of attachments the relevant application standard should be consulted.

36 Welding procedure

36.1 Each run of weld metal shall be clean and free from slag before the next run is deposited. To ensure full penetration in a double-sided weld, the under surface of the root run shall be removed by chipping or grinding to give a clean metallic surface, before welding from the other side is commenced, unless the welding procedure has proved that full penetration will be achieved without back gouging.

36.2 If partial penetration welds are used, the form of the preparation shall be specified on the drawings. The method and amount of inspection shall be agreed between the contracting parties [see 2.2 j)].

36.3 Any necessary pre-heating and post-weld heat treatment shall be as given in Table 5 and Table 6 respectively.

36.4 For pipe of nominal thickness 5 mm or less, care shall be taken so that there is no over-heating or burn-through of the pipe (see clauses 47 and 50).

Section 7. Flanges

37 General

Section 1 of this standard details the basic procedure requirements with which all welded joints between pipes and fittings shall comply. These basic requirements are supplemented by the specific requirements detailed in this section 7. Both section 1 and section 7 of this standard shall be applied in determining the full procedure requirements.

38 Welding neck flanges

The procedure to be applied for the welding of welding neck flanges (see Figure 10) shall be the same as for normal butt welds, for which the requirements of section 2 shall apply.

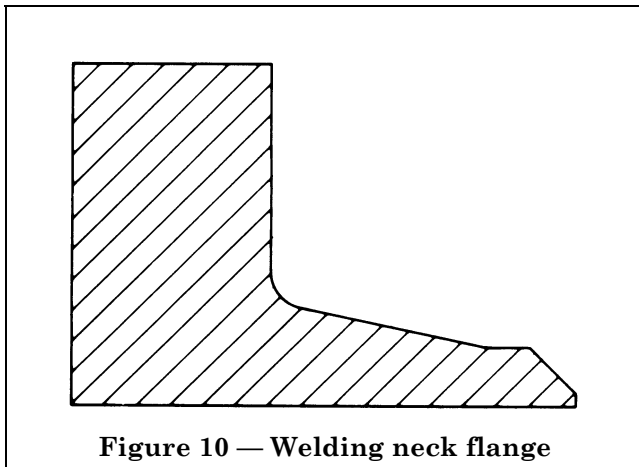

Figure 10 — Welding neck flange

39 Plate flanges

39.1 Fit

The flange shall be a loose fit on the pipe but the clearance between the outside diameter of the pipe and bore of the flange shall not exceed 3.0 mm at any point and the sum of the clearances on any diameter shall not exceed 5.0 mm.

NOTE The flange should be substantially concentric with the pipe.

39.2 Preparation

When thermal cutting is used to prepare flanges, the appropriate pre-heating requirements specified in clause 18 shall be applied.

NOTE 1 Typical weld preparations for plate flanges are given in D.4.

NOTE 2 This standard deals only with preparation from the point of view of ensuring the quality of the welds. Attention is drawn, for instance, to BS 806.

Section 8. Inspection

40 Requirements for visual examination of completed welds

40.1 General

All welds shall be visually examined (see BS 5289) on the outside surface and, where practicable, in the bore (with the aid of optical instruments if necessary) and shall show the features detailed in 40.2, 40.3, 40.4, 40.5 and 40.6.

Visually detectable defects shall be assessed in accordance with clause 42.

If the purchaser requires completed welds to be ground, this shall be stated in the enquiry and order [see 2.1 e)]. When a weld is to be ground, over-heating the joint due to the grinding action shall be avoided.

40.2 Profile of external surface

Weld metal shall be properly fused with the parent metal without significant undercutting or overlapping at the toes of the weld; slight intermittent undercut shall be permitted provided that it does not form a sharp notch and that it meets the following requirements.

The toes of undressed welds shall blend smoothly and gradually into the parent metal and the depth of any local undercut shall be in accordance with the appropriate values given in Table 9.

The toes of dressed welds shall be free from undercut or other depressions and the depth of underflushing shall be in accordance with the appropriate values given in Table 9.

External weld reinforcement shall be in accordance with the appropriate values given in Table 9 and shall be substantially symmetrical about the centre-line of the joint. In all cases it shall be of smooth contour blending smoothly at the toes with the parent metal.

NOTE The shape of the reinforcement may vary according to the type of filler metal used, the welding technique and the welding position.

Table 8 — Penetration of root bead

Nominal size of pipe	Max. penetration in bore ^a	Max. restriction in bore ^a
mm	mm	mm
Less than 12	1.0	1.5
12 up to but not including 25	1.5	2.0
25 up to but not including 50	2.5	3.0
50 up to but not including 100	3.0	5.0
100 and larger	3.0	6.0

^a Values rounded to nearest 0.5 mm.

The surface of the weld shall be free from porosity and loose or excessive scale. Any crater pipes and surface cavities shall be in accordance with the appropriate values given in Table 9.

40.3 Smoothness of undressed welds

The stop and start of each run of weld shall merge smoothly and shall show no pronounced hump or crater in the weld surface.

40.4 Penetration bead in unbacked welds

The weld shall fuse the pipe at the root without protruding excessively into the bore of the pipe. The maximum penetration of the root bead into the bore shall be as given in Table 8, although an occasional local slight excess of penetration is permitted.

If the purchaser requires limits on protrusion lower than specified in Table 8, this shall be stated in the enquiry and order [see 2.1 f)].

40.5 Root concavity

If there is complete root fusion, root concavity (or sinkage) at the bore shall be acceptable provided that:

- the bore surface of the joint is of smooth contour;
- the depth of root concavity is not greater than that given in Table 9;
- the thickness of the weld is not less than the pipe thickness.

40.6 Profile of root bead

The root bead or any concavity shall merge smoothly into the adjacent surfaces.

41 Non-destructive testing

41.1 General

41.1.1 The quality of pressure-containing welds shall be assessed by radiographic and/or ultrasonic examination, as agreed between the contracting parties, in accordance with clause 42 [see 2.2 k)].

The weld profile and surface shall be suitable for radiographic and/or ultrasonic examination; this might entail dressing the weld.

NOTE 1 Steels that are susceptible to cracking during heat treatment should be examined after post-weld heat treatment, preferably by ultrasonic examination.

NOTE 2 Guidance on the use of radiographic and ultrasonic examination is given in Appendix F.

41.1.2 At least 10 % of each welder's production of butt joints in accordance with section 2, selected at random, shall be subjected to full radiographic and/or ultrasonic examination, although a higher minimum percentage shall be used when this is specified by the relevant application standard or by the purchaser [see 2.1 g)].

41.1.3 The inspection and testing requirements for other than butt joints in accordance with section 2 shall be agreed between the contracting parties [see 2.2 l)].

41.2 Radiographic examination of butt joints

When radiographic examination is used, the technique employed shall be one of the following from BS 2910, as agreed between the contracting parties [see 2.2 m)]:

technique numbers 1, 4, 7, 10, 13 or 16.

NOTE For guidance on the radiographic sensitivity that can be obtained using wire-type and step/hole-type image quality indicators, see Table 7 of BS 3971:1980.

41.3 Ultrasonic examination

When ultrasonic examination is used (see BS 3923-1), it shall be demonstrated that the equipment and the technique to be used are satisfactory.

The operator shall be qualified to use the equipment, apply the technique and interpret the results of the examination.

Butt joints in $\frac{1}{2}$ Cr $\frac{1}{2}$ Mo $\frac{1}{4}$ V steel shall be subjected to ultrasonic examination which shall be carried out after post-weld heat treatment.

41.4 Magnetic particle and liquid penetrant testing

41.4.1 Magnetic particle testing (see BS 6072), other than in accordance with 41.4.2, or liquid penetrant testing (see BS 6443) shall be carried out:

- a) when specified in the application standard, or
- b) when required by the purchaser [see 2.1 h)].

41.4.2 All welds joining $\frac{1}{2}$ Cr $\frac{1}{2}$ Mo $\frac{1}{4}$ V steel pipes shall be subjected to magnetic particle testing which shall be carried out after post-weld heat treatment.

41.5 Re-examination

When random radiographic or ultrasonic examination reveals unacceptable defects in a weld, at least two further welds in the group represented by this weld shall be examined by the same method. The examination shall cover not less than one-third of the circumference of pipes of less than 168.3 mm outside diameter and not less than 300 mm of the circumference of larger pipes, the location being selected by the inspector. If the examination of these further welds in the group reveals no unacceptable defects, the defects in the first weld shall be repaired and re-examined by the original method. If the repair is satisfactory, the group of welds shall be accepted.

If the examination of either of the further welds in the group reveals unacceptable defects, each weld in the group shall be examined by the same method over its complete circumference. Unacceptable defects shall be repaired and then re-examined by the original method.

42 Defect limitations

42.1 Taking account of the non-destructive testing method(s) used (see Appendix F), any *one* of the types of defect that does not comply with *any* of the relevant limits given in Table 9 shall be sufficient cause for rejection, unless alternative limits are specified by the purchaser in accordance with 42.2.

NOTE 1 The effects of weld defects on the service performance of a joint are influenced by the location and disposition of the defects; in general, those located in the body of the weld are less serious than those in the root, a factor that should be borne in mind by the inspector when considering the rejection of joints that appear to be borderline in quality as assessed by the defect limitations specified.

NOTE 2 Multiple-type defects contained within the same weld, either superimposed or interposed, which are individually acceptable as isolated defects should be considered collectively by the inspector when assessing the weld quality.

NOTE 3 As an alternative to the defect limits, including cracks, given in Table 9, the technique of Engineering Critical Assessment may be used to derive other values by agreement between the contracting parties (see PD 6493).

42.2 When the service conditions of the pipework are such that some or all of the defect limits given in Table 9 are inappropriate, alternative limits shall be specified by the purchaser in the enquiry and order (see 2.1 i) and notes 1, 2 and 3 to 42.1).

NOTE The dimensional limits of defects given in Table 9 are intended to ensure a quality of welding that may be regarded as class I. Service conditions may exist, however, that require a higher standard, for example those involving crevice corrosion or cyclic stressing which may lead to fatigue and for which relatively defect-free weld roots are desirable.

Table 9 — Defect limits

Defect type	Defect limits				
	For pipe up to and including 2.9 mm thick (<i>t</i>)	For pipe over 2.9 mm up to and including 4.5 mm thick (<i>t</i>)	For pipe over 4.5 mm up to and including 6.3 mm thick (<i>t</i>)	For pipe over 6.3 mm up to and including 20 mm thick (<i>t</i>)	For pipes over 20 mm thick (<i>t</i>)
Undercut (depth) (undressed welds)	10 % <i>t</i> max. (see 40.2)	10 % <i>t</i> max. (see 40.2)	Smaller of 10 % <i>t</i> or 0.5 mm max. (see 40.2)	0.5 mm max. (see 40.2)	0.5 mm max. (see 40.2)
Underflushing (dressed welds)	10 % <i>t</i> max. (see 40.2)	10 % <i>t</i> max. (see 40.2)	10 % <i>t</i> max. (see 40.2)	1.0 mm max. (see 40.2)	1.0 mm max. (see 40.2)
Reinforcement height	1.0 mm min. 2.5 mm max. (see 40.2)	1.0 mm min. 3.0 mm max. (see 40.2)	1.0 mm min. 5.0 mm max. (see 40.2)	1.0 mm min. 5.0 mm max. (see 40.2)	1.0 mm min. 5.0 mm max. (see 40.2)
Misalignment	See 26.1 and Table 7	See 26.1 and Table 7	See 26.1 and Table 7	See 26.1 and Table 7	See 26.1 and Table 7
Root protrusion	See 40.4 and Table 8	See 40.4 and Table 8	See 40.4 and Table 8	See 40.4 and Table 8	See 40.4 and Table 8
Root concavity	1.0 mm max. (see 40.5)	1.5 mm max. (see 40.5)	1.5 mm max. (see 40.5)	1.5 mm max. (see 40.5)	2.0 mm max. (see 40.5)
Crater pipes and surface cavities	Length 3.0 mm max. Height 20 % <i>t</i> max.	Length 4.0 mm max. Height 20 % <i>t</i> max.	Length 5.0 mm max. Height 20 % <i>t</i> max.	Length 6.0 mm max. Height 1.5 mm max.	Length 10.0 mm max. Height 2.0 mm max.
Cracks	Not permitted	Not permitted	Not permitted	Not permitted	Not permitted
Lack of root penetration	Length 3.0 mm max. ^a Height 20 % <i>t</i> max.	Length 6.0 mm max. ^a Height 20 % <i>t</i> max.	Length 10.0 mm max. ^a Height 1.5 mm max.	Length 10.0 mm max. ^a Height 1.5 mm max.	Length 12.0 mm max. ^a Height 2.0 mm max.
Lack of root fusion	Length 3.0 mm max. ^a Height 20 % <i>t</i> max.	Length 6.0 mm max. ^a Height 20 % <i>t</i> max.	Length 10.0 mm max. ^a Height 1.5 mm max.	Length 10.0 mm max. ^a Height 1.5 mm max.	Length 12.0 mm max. ^a Height 2.0 mm max.
Lack of side fusion	Length 3.0 mm max. ^a Height 20 % <i>t</i> max.	Length 6.0 mm max. ^a Height 20 % <i>t</i> max.	Length 10.0 mm max. ^a Height 1.5 mm max.	Length 12.0 mm max. ^a Height 1.5 mm max.	Length 15.0 mm max. ^a Height 2.0 mm max.
Lack of inter-run fusion	Length 3.0 mm max. ^a Height 20 % <i>t</i> max.	Length 6.0 mm max. ^a Height 20 % <i>t</i> max.	Length 10.0 mm max. ^a Height 1.5 mm max.	Length 12.0 mm max. ^a Height 1.5 mm max.	Length 15.0 mm max. ^a Height 2.0 mm max.
Wormholes	Length 3.0 mm max. ^a Height 20 % <i>t</i> max.	Length 6.0 mm max. ^a Height 20 % <i>t</i> max.	Length 10.0 mm max. ^a Height 1.5 mm max.	Length 12.0 mm max. ^a Height 1.5 mm max.	Length 15.0 mm max. ^a Height 2.0 mm max.
Porosity (isolated)	20 % <i>t</i> max.	20 % <i>t</i> max.	20 % <i>t</i> max.	20 % <i>t</i> max.	5.0 mm max.
Porosity (scattered)	Aggregate length of pores 3.0 mm max. in any 25 mm length of weld ^b	Aggregate length of pores 5.0 mm max. in any 25 mm length of weld ^b	Aggregate length of pores 6.0 mm max. in any 25 mm length of weld ^b	Aggregate length of pores 8.0 mm max. in any 25 mm length of weld ^b	Aggregate length of pores 12.0 mm max. in any 25 mm length of weld ^b
Porosity (localized) (e.g. stop/start porosity)	Total area of porosity 1.5 mm ² max. ^c in any 6.0 mm dia.	Total area of porosity 2.0 mm ² max. ^d in any 6.0 mm dia.	Total area of porosity 2.0 mm ² max. ^d in any 6.0 mm dia.	Total area of porosity 3.0 mm ² max. ^e in any 6.0 mm dia.	Total area of porosity 6.0 mm ² max. ^f in any 6.0 mm dia.
Slag inclusions	Length 3.0 mm max. Height 20 % <i>t</i> max. ^b	Length 6.0 mm max. Height 20 % <i>t</i> max. ^b	Length 12.0 mm max. Height 1.5 mm max. ^b	Length 15.0 mm max. Height 1.5 mm max. ^b	Length 20.0 mm max. Height 2.0 mm max. ^b
Tungsten inclusions (isolated)	20 % <i>t</i> max.	20 % <i>t</i> max.	20 % <i>t</i> max.	20 % <i>t</i> max.	5.0 mm max.
Tungsten inclusions (scattered)	Aggregate length of inclusions 3.0 mm max. in any 25 mm length of weld ^b	Aggregate length of inclusions 5.0 mm max. in any 25 mm length of weld ^b	Aggregate length of inclusions 6.0 mm max. in any 25 mm length of weld ^b	Aggregate length of inclusions 8.0 mm max. in any 25 mm length of weld ^b	Aggregate length of inclusions 12.0 mm max. in any 25 mm length of weld ^b

NOTE Length is measured with respect to the long axis of the weld, i.e. circumferentially. Height is measured with respect to the actual throat thickness of the weld, i.e. radially.

^a Adjacent defects with combined lengths greater than that permitted for isolated defects are to be separated by a distance not less than six times the length of the longer defect. Defects generally disposed around the weld are cause for rejection.

^b Adjacent defects with combined sizes greater than that permitted for isolated defects are to be separated by a distance not less than four times the size of the longer defect. Defects generally disposed around the weld are to be investigated.

^c Porosity of total area 1.5 mm² is approximately equivalent to the area of three pores 0.8 mm in diameter.

^d Porosity of total area 2.0 mm² is approximately equivalent to the area of four pores 0.8 mm in diameter.

^e Porosity of total area 3.0 mm² is approximately equivalent to the area of six pores 0.8 mm in diameter.

^f Porosity of total area 6.0 mm² is approximately equivalent to the are of twelve pores 0.8 mm in diameter.

Section 9. Rectification of defective welds

43 Removal of defects

Where welds fail to comply wholly or in part with the requirements of section 8 all unacceptable defects shall be removed.

NOTE 1 The technique of Engineering Critical Assessment may be used by agreement between the contracting parties to determine whether a defect, such as a crack, needs to be removed (see PD 6493).

Defects shall be removed by chipping, grinding, machining, thermal cutting or thermal gouging. When thermal cutting or thermal gouging is used, pre-heating in accordance with clause 18 shall be applied.

Major repairs involve:

- a) cutting through the weld; or
- b) cutting out a length of pipe containing the weld (see clause 11); or
- c) removing weld metal down to the backing ring (where used).

A cut through a weld as in a) or through the pipe as in b) shall be made by machine thermal cutting, guided hand thermal cutting, saw cutting or by machine cutting. Following thermal cutting, fusion faces shall be prepared by grinding or machining such that a smooth surface free for serrations is obtained.

NOTE 2 When thermal cutting is used it may be necessary to compensate for any loss of length that may occur.

44 Preparation for re-welding

44.1 General

Any repair to a weld shall be reported to the inspecting authority. If the repair is made as a consequence of non-destructive testing, the records relating to the original defects shall be made available.

44.2 Partial removal of weld

The cut out portion shall be sufficiently deep and long to remove the defect. The exposed surfaces shall then be subjected to either magnetic particle testing (see BS 6072) or liquid penetrant testing (see BS 6443). At the ends and sides of the cut there shall be a gradual taper from the base of the cut to the surface of the weld metal. The width and profile of cut shall be such as will give adequate access for re-welding.

The removal of the last 6.0 mm of weld metal down to a backing ring shall be carried out only by grinding.

NOTE When the root of the weld is accessible from the bore of the pipe, a repair may be made from that position (see 29.4.2).

44.3 Complete removal of weld

Where a cut has been made through a defective weld and there has been no serious loss of pipe length, the weld preparation shall be re-made in accordance with the appropriate section of this standard.

Where it is necessary to compensate for loss of pipe length, this shall be done:

- a) by inserting a new length of pipe and preparing the two joints in accordance with section 2; or
- b) by building up the base of the groove with suitable weld metal; if this method is used magnetic particle testing (see BS 6072) or some other method of non-destructive testing agreed between the contracting parties shall be applied after building-up [see 2.2 n)]; or
- c) by adopting a joint preparation incorporating a wider root gap, provided agreement between the contracting parties is obtained on the use of this method [see 2.2 o)].

45 Re-welding

Before re-welding, the weld metal and welding procedure shall have been approved by the inspecting authority or the purchaser.

When a weld is completely cut out and re-made, as a minimum requirement, the repaired weld shall be subjected to the same testing and inspection requirements as the original weld.

When a local repair is made, as a minimum requirement, the full extent of the repair shall be inspected, but for a circumferential weld when the extent of the repair exceeds one-eighth of the circumference the whole of the weld shall be inspected.

Section 10. Welding procedure approval

46 General

46.1 Welding shall be controlled by reference to BS EN 288 as defined below.

All welding shall be performed in accordance with the welding procedure specification or other work instruction written in accordance with BS EN 288-2. These welding procedure specifications shall be substantiated by a welding procedure test, either:

- a) in accordance with BS EN 288-3; or
- b) a pre-existing weld procedure test performed to BS 4870-1 previously acceptable to an examiner or test body, except that the range of approval of this test shall be in accordance with the ranges in BS EN 288-3.

Existing procedures to BS 4870-1 shall be considered technically equivalent to BS EN 288-3 when similar types of test have been carried out. Thus the bend tests in BS 4870-1 shall be considered equivalent to those in BS EN 288-3 even though the exact number and bend angle differ. Similarly, visual, radiographic, ultrasonic, surface crack detection, transverse tensile, hardness, macro-examination and impact tests shall be considered equivalent.

Where BS EN 288-3 calls for a type of test to be performed and this has not been carried out on the pre-existing BS 4870-1 procedure qualification test, additional testing, as described in clause 0 of BS EN 288-3 shall be carried out. For example, if impact tests have not been carried out on the BS 4870-1 test pieces it is only necessary to do an additional set of impact tests on a test piece made in accordance with BS EN 288-3.

The alternative methods of approval of welding procedures addressed in BS EN 288-1 shall not be permitted for pipe welding in accordance with BS 2633. By agreement, where specific joint types are not compatible with the testing requirements of BS EN 288-3 then a pre-production test shall be considered and shall be tested to the relevant requirements of BS EN 288-3 where practicable.

NOTE It is recommended that welding procedure tests carried out in accordance with this clause and witnessed by an examiner or test body should be accepted by other examiner or test bodies provided that all the provisions have been fulfilled.

46.2 When the purchaser requires that welding procedure tests employ pipe of specified diameter and thickness, such a requirement shall be stated on the enquiry and order [see 2.1 j)].

46.3 Tungsten inclusions shall be assessed in accordance with Table 9.

47 Attachments to thin pipes

When attachment welds are to be made to pipes of wall thickness equal to or less than 5 mm, a test shall be made using a typical weld detail to determine that burn-through does not occur. The test weld shall be made on pipe of contract thickness and the minimum approved thickness shall be the thickness welded.

NOTE The approval may apply to other contracts.

48 Branch welds

Branch weld tests shall be performed in accordance with BS EN 288-3.

NOTE This may need to be supplemented by a butt weld test piece to obtain relevant mechanical data.

Section 11. Welder approval

49 General

49.1 Approval testing of welders shall be carried out in accordance with BS EN 287-1. Welders who previously held approvals to BS 4871-1 shall be considered to be approved to work with the following provisos.

- a) The range of approval of the welder shall be in accordance with BS EN 287-1.
- b) Welder approval tests to BS 4871-1 shall be considered technically equivalent to BS EN 287-1 except that for all MIG/MAG welding, bend tests shall be carried out. If bend tests for these processes have not been carried out during the original test, reapproval to BS EN 287-2 shall be performed.
- c) The prolongation of a BS 4871-1 approval test, if required, shall be made at six-monthly intervals by the employer/manufacture, in accordance with **10.1** of BS EN 287-1, for the period of two years from the date of effect of BS EN 287-1, i.e. from 1 May 1992.
- d) The prolongation of BS 4871-1 approval test in excess of the initial two years from 1 May 1992 shall be made in accordance with **10.2** of BS EN 287-1:1992 in conjunction with an examiner or test body.

The welder who satisfactorily completes the welding procedure test shall thereby be approved in those procedures without undergoing welder approval tests except for fillet welds where the extra tests required by BS EN 287-1 (2 macros or test piece fracture) shall be completed.

NOTE It is recommended that welder approval tests carried out in accordance with this clause and witnessed by an examiner or test body should be accepted by other examiners or test bodies provided that all the provisions have been fulfilled.

49.2 Tungsten inclusions shall be assessed in accordance with Table 9.

50 Attachments to thin pipes

Welders to be engaged in welding attachments to pipes of wall thickness equal to or less than 5 mm shall demonstrate their ability to do so on contract thickness material. The test weld shall be made on pipe of contract thickness and the minimum approved thickness shall be the thickness needed.

Appendix A Classes of operating conditions

Table 10 gives guidance on class I and class II operating conditions of pipework which, as stated in the foreword, are only one set of factors that have to be taken into account in deciding the class of welding required for a particular application.

Table 10 — Classes of operating conditions

Service	Temperature	Pressure (bar ^a)		
		Up to and including 17	Over 17 up to and including 24	Over 24
Gases (including steam)	°C			
	Below – 20	Class II	Class I	Class I
	Over – 20 up to and including 220	Class II	Class I	Class I
	Over 220	Class I	Class I	Class I
Liquids	Below – 20	Class II	Class I	Class I
	Over – 20 up to and including 95	Class II	Class II	Class I
	Over 95 up to and including 200	Class II	Class I	Class I
	Over 200	Class I	Class I	Class I

^a 1 bar = 10⁵ N/m² = 100 kPa.

Appendix B Grades of steel in British Standards and similar grades for pipe in ASTM and DIN standards

B.1 Table 11 gives details of grades in British Standards for the types of steel listed in Table 1.

Table 11 — Grades of steel in British Standards

Type of steel	Pipe standards grades and types	Pipe fittings standards	Flange standards
C and C-Mn (≤ 0.25 C)	BS 3059-1:320 BS 3059-2:360 and BS 3059-2:440 BS 3601:320, BS 3601:360 and BS 3601:430 BS 3602-1:360, BS 3602-1:430 and BS 3602-1:500 Nb BS 3602-2:430 BS 3603:430 LT BS 3606:320 and BS 3606:440	BS 1640-3 BS 1965-1 BS 3799	BS 1560-3.1 BS 4504-3.1 BS 4504-3.2
C and C-Mn (> 0.25 C ≤ 0.4 C)	—	BS 1640-3 ^a	BS 1560-3.1
C-Mo	BS 3059-2:243 BS 3606:243, BS 3606:245 and BS 3606:261	BS 1640-3	BS 1560-3.1 BS 4504-3.1 BS 4504-3.2
1 Cr ½ Mo	BS 3059-2:620 BS 3604:620–440 BS 3606:620	—	BS 1560-3.1 BS 4504-3.1 BS 4504-3.2
1¼ Cr ½ Mo	BS 3640:621 BS 3606:621	BS 1640-3 BS 3799	BS 1560-3.1
1.25 Ni Cu Mo Nb	BS 3604:591	—	—
½ Cr ½ Mo ¼ V	BS 3604:660	—	—
2¼ Cr 1 Mo	BS 3059-2:622–490 BS 3604:622 BS 3606:622	BS 1640-3	BS 1560-3.1
5 Cr ½ Mo	BS 3604:625 BS 3606:625	BS 1640-3	BS 1560-3.1
7 Cr ½ Mo	—	—	—
9 Cr 1 Mo	BS 3059-2:629–590 BS 3604:629–470 and BS 3604:629–590	—	—
9 Cr 1 Mo V Nb N	BS 3059-2 BS 3604-1	—	—
12 Cr Mo V (W)	BS 3059-2:762 BS 3604:762	—	—
3½ Ni	BS 3603:503 LT	BS 1640-3 BS 3799	— —
9 Ni	BS 3603:509 LT	—	—

^a 0.30 % maximum carbon content.

B.2 Table 12 gives details of corresponding grades in ASTM and DIN standards for the grades of pipe in British Standards, on the basis of similar weldability although they may not have identical mechanical properties or chemical composition.

The use of alternative material specifications may allow the steel manufacturer to produce material in the quenched and tempered condition, in which case additional precautions may be necessary during welding.

Table 12 — Grades in ASTM and DIN standards of similar weldability to British Standard grades of pipe

British Standard	ASTM standard	DIN standard
BS 3059-1:320 BS 3059-2:360 and BS 3059-2:440 BS 3601:320, BS 3601:360 and BS 3601:430 BS 3602-1:360, BS 3602-1:430 and BS 3602-1:500 Nb BS 3602-2:430 BS 3606:320 and BS 3606:440	A106 Gr A A106 Gr B (if carbon is restricted to 0.25 % max.)	DIN 17175 St 35.8 DIN 17177 St 37.8 DIN 17175 St 45.8 DIN 17177 St 42.8 DIN 17175 17 Mn 4 DIN 17175 19 Mn 5
BS 3603:430 LT	A333 Gr 1 and Gr 6 (if carbon is restricted to 0.20 % max.)	DIN 17173 TT ST 35 N DIN 17174
BS 3059-2:243 BS 3606:243 and BS 3606:261	A335 Gr P1	DIN 17175 15 Mo 3
BS 3059-2:620 BS 3604:620-440 BS 3604:621 BS 3606:620 BS 3606:621	A335 Gr P11 A335 Gr P12	DIN 17175 13 Cr Mo 4 4
BS 3604:591	—	Vd TÜV 377/2 15 NiCuMoNb 5
BS 3604:660	—	DIN 17175 14 MoV 6 3
BS 3604:622 BS 3606:622	A335 Gr P22	DIN 17175 10 CrMo 9 10
BS 3604:625	A335 Gr P5	—
BS 3604:629-470 BS 3604:629-590	A335 Gr P9	—
BS 3059-2:762 BS 3604:762	—	DIN 17175 CrMoV 12 1
BS 3059-2 BS 3604-1	A213 T91 A335 Gr P91	—
BS 3603:503 LT	A333 Gr 3	DIC 17174 10 Ni 14
BS 3603:509:LT	A333 Gr 8	DIN 17173 X8 NI 9 DIN 17174

Appendix C Guidance on suitable types of weld metal

C.1 Mechanical properties

In general, the mechanical properties should be at least equal to the minimum in the specification for the parent material or that of the lower strength parent material in the case of joints between different materials.

C.2 Chemical composition

In 5.2 the weld metal is required to be of a chemical composition compatible with that of the parent material. It is not always desirable for reasons of weldability or behaviour in service, to use an exactly equivalent chemical composition, nor is it essential for design purposes. The use of 2¼ Cr 1 Mo weld metal on ½ Cr ½ Mo ¼ V pipework is an example of this concept; the use of ½ Cr ½ Mo ¼ V weld metal is deprecated.

The weld metal should be selected in accordance with the “preferred” columns of Table 13 and an alternative should only be used by agreement between the contracting parties.

C.3 Electrodes and filler wires

Table 13 details the appropriate British Standards covering the types of electrodes and filler wires that will give weld metal having a chemical composition compatible with that of the parent material. It also provides a guide to the limits of permissible relaxation in chemical composition of the weld metal relative to that of the parent material by giving alternative types of electrode, filler wire and filler rods that may be used by agreement between the contracting parties (see 5.2).

Table 13 — British Standards for electrodes and filler wires

NOTE Where no welding consumables to a British Standard are quoted, proprietary consumables may be obtainable.					
Type of steel	Preferred		Alternative (by agreement see C.2)		
	Covered electrodes	Wires for gas-shielded processes ^a	Chemical composition (deposited metal)	Covered electrodes	Wires for gas-shielded processes ^a
C and C-Mn (≤ 0.25 C)	BS EN 499 E 35 × E 38 × E 42 ×	BS EN 440 G2 Ti G2 Si G3 Si1	—	—	—
C and C-Mn (> 0.25 C ≤ 0.4 C)	BS EN 499 E 42 × E 46 × E 50 ×	BS EN 440 G2 Ti G2 Si G3 Si1	C or C-Mn steel	BS EN 499 E 35 × E 38 ×	—
C-Mo	BS 2493 1CrMoLB 1CrMoB 1CrMoR	BS 2901-1 Type A32	C or C-Mn steel	BS EN 499 E 42 × E 46 × E 50 ×	BS EN 440 G2 Ti G2 Si G3 Si1
1 Cr ½ Mo 1¼ Cr ½ Mo	BS 2493 1CrMoLB 1CrMoB 1CrMoR	BS 2901-1 Type A32	C-Mo	BS 2493 MoB MoC MoR	BS EN 440 G2 Mo G4 Mo
			C or C-Mn steel (< 0.25 C) for root run only ^b	BS EN 499 E 35 × E 38 × E 42 ×	BS EN 440 G2 Ti G2 Si G3 Si1

Table 13 — British Standards for electrodes and filler wires

NOTE Where no welding consumables to a British Standard are quoted, proprietary consumables may be obtainable.					
Type of steel	Preferred		Alternative (by agreement see C.2)		
	Covered electrodes	Wires for gas-shielded processes ^a	Chemical composition (deposited metal)	Covered electrodes	Wires for gas-shielded processes ^a
1.25 Ni Cu Mo Nb	(Matching composition)	BS EN 440 G2 Mo G4 Mo	C or C-Mn steel (< 0.25 C) for root run only ^b	BS EN 499 E 35 × E 38 × E 42 ×	BS EN 440 G2 Ti G2 Si G3 Si1
½ Cr ½ Mo ¼ V	BS 2493 2CrMoB	BS 2901-1 Type A33	C or C-Mn steel (< 0.25 C) for root run only ^b	BS EN 499 E 35 × E 38 × E 42 ×	BS EN 440 G2 Ti G2 Si G3 Si1
2¼ Cr 1 Mo	BS 2493 2CrMoLB 2CrMoB 1CrMoR	BS 2901-1 Type A33	1 Cr Mo except where corrosion resistance is important	BS 2493 1CrMoLB 1CrMoB 1CrMoR	BS 2901-1 Type A32
			C or C-Mn steel (< 0.25 C) for root run only ^b	BS EN 499 E 35 × E 38 × E 42 ×	BS EN 440 G2 Ti G2 Si G3 Si1
5 Cr ½ Mo	BS 2493 5CrMoB	BS 2901-1 Type A34	High nickel alloy weld metal	—	—
7 Cr ½ Mo	BS 2493 7 CrMoB	—	9 Cr Mo or high nickel alloy weld metal	BS 2493 9CrMoB	—
9 Cr 1 Mo	BS 2493 9CrMoB	BS 2901-1 Type A35	High nickel alloy weld metal	—	—
9 Cr 1 Mo V Nb N	(Nominal matching composition)	(Nominal matching composition)	9 Cr 1 Mo weld metal for root run only	—	BS 2901-1 Type A35 BS 2943 9CrMoB
12 Cr Mo V (W)	BS 2493 12CrMoVB 12CrMoWVB	—	High nickel alloy weld metal	—	—
3½ Ni	BS 2493 3NiLB 3NiB	—		—	—
9 Ni	—	—	—	—	—

^a The appropriate wire should be chosen having regard to the oxidizing nature of the shielding gas used (see 6.1) and the quality of the steel being welded.

^b C or C-Mn steel for root runs in alloy steel pipe should not be used for pipe thickness ≤ 12.5 mm.

Appendix D Typical joint preparations

D.1 Typical butt joint preparations are shown in Figure 11 to Figure 16.

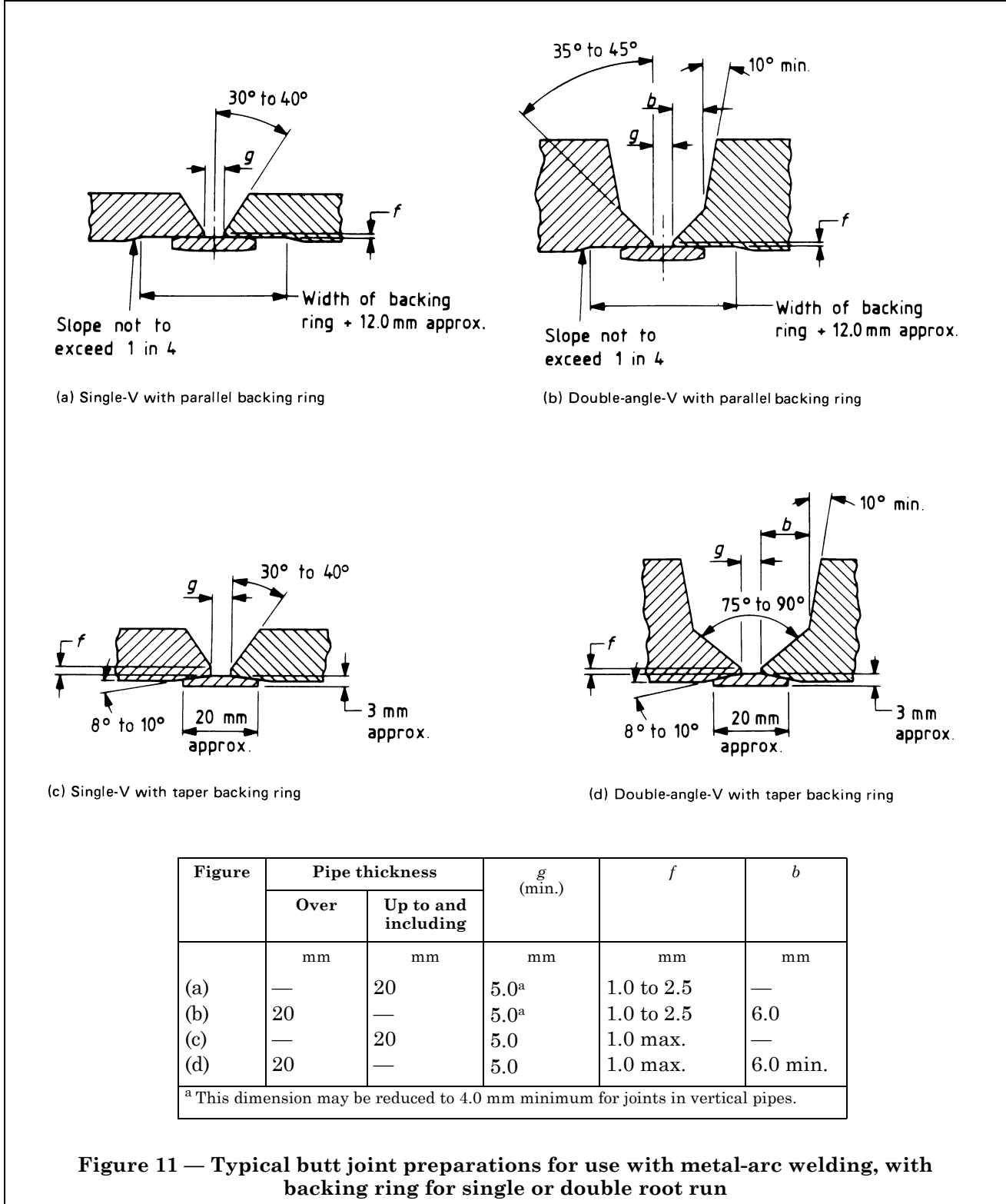

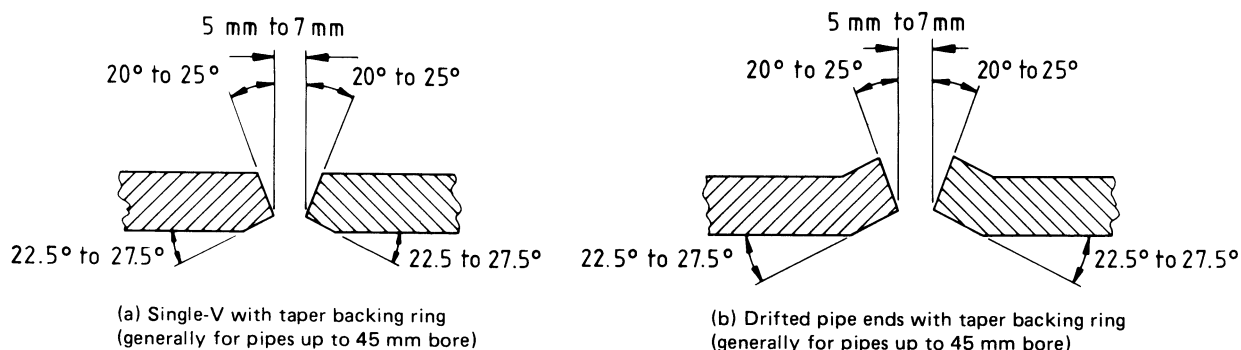

Figure 12 — Typical butt joint preparations for use with metal-arc welding with backing ring where protrusion into the bore is not permissible

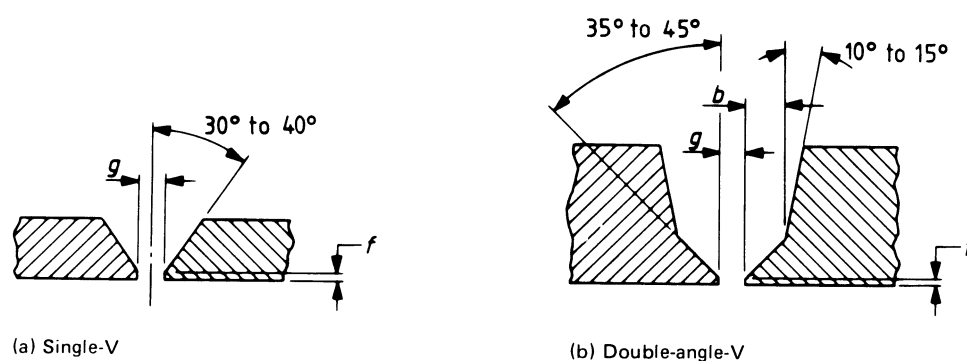
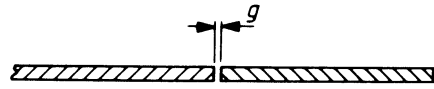

Figure	Pipe thickness		g^a	f	b
	Over	Up to and including			
	mm	mm	mm	mm	mm
(a)	—	20	1.5 to 4.0	1.5 ± 1.0	—
(b)	20	—	2.5 to 4.0	1.5 ± 1.0	6.0

^a The actual gap will vary according to the welding technique and welding position used (see also clause 13).

Figure 13 — Typical butt joint preparations for use with metal-arc welding, without backing ring



(a) Square butt

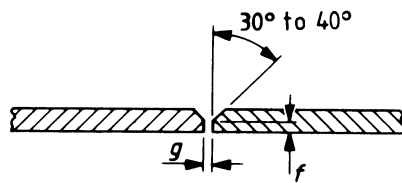

(b) Single-V

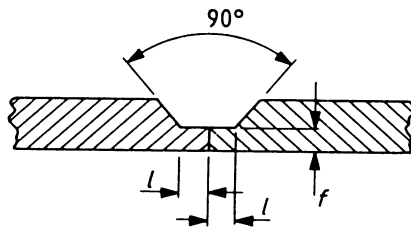

(c) Single-V with lands

Figure	Pipe thickness		<i>g</i>	<i>f</i>	<i>l</i>
	Over	Up to and including			
	mm	mm	mm	mm	mm
(a)	—	2.3	0 + 1.5	—	—
(b)	2.3	6.3	0 + 1.5	1.5	—
(c)	3.2	6.3	0	2.5	3.0

Figure 14 — Typical butt joint preparations for use with manual TIG welding, with or without filler wire

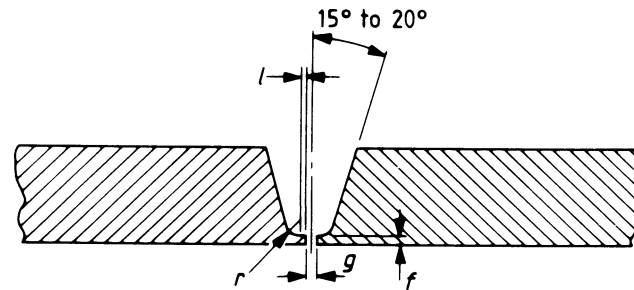

(a) Single-J with lands, any thickness

Figure	<i>g</i>			<i>f</i>	<i>l</i>	<i>r</i>
	Without filler wire or insert	Using filler wire	Using fusible insert			
(a)	0	mm 3.0 max.	To suit type and make of fusible insert used	mm 1.5 to 2.5	mm 1.0 to 1.5	mm 3.0 to 5.0

Figure 15 — Typical butt joint preparations for use with TIG welding for the root run, with or without filler wire, or with fusible insert

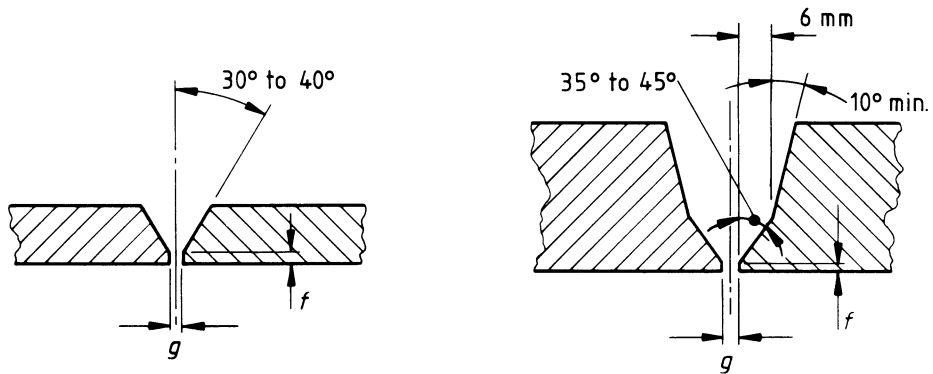

(b) Single-V, generally for pipes up to 20 mm thick

(c) Double-angle-V, generally for pipes 20 mm thick and over

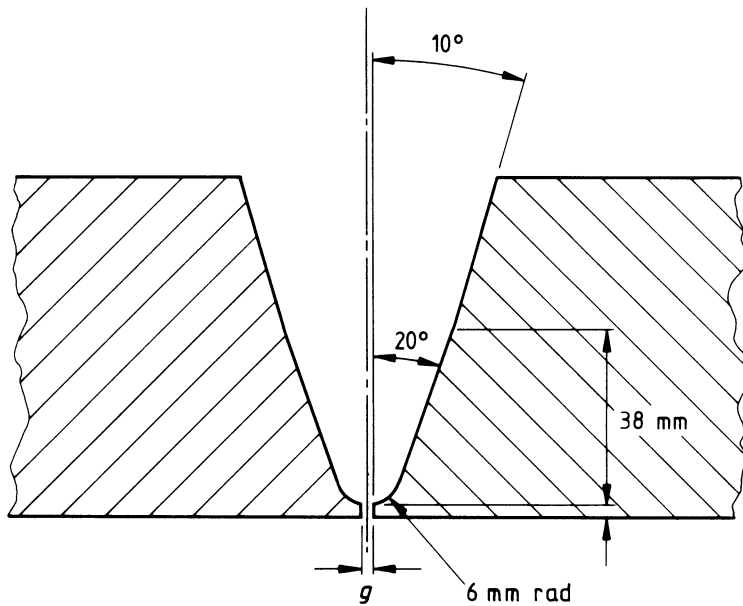

(d) Double-angle-J, for pipes over 38 mm thick

Figure	<i>g</i>		<i>f</i>
	Using filler wire	Using fusible insert	
	mm		mm
(b)	1.0 to 3.0	To suit type and make	1.5 to 2.5
(c)	1.0 to 3.0	of fusible insert used	1.5 to 2.5
(d)	1.0 to 3.0		1.5 to 2.5

Figure 15 — Typical butt joint preparations for use with TIG welding for the root run, with or without filler wire, or with fusible insert (concluded)

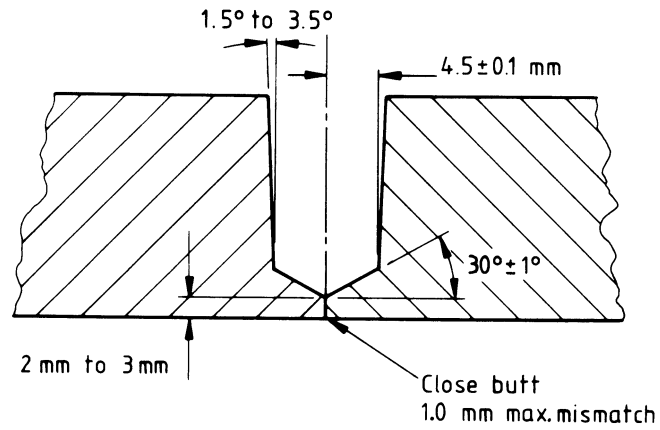

(a) For use with automatic TIG or MIG welding

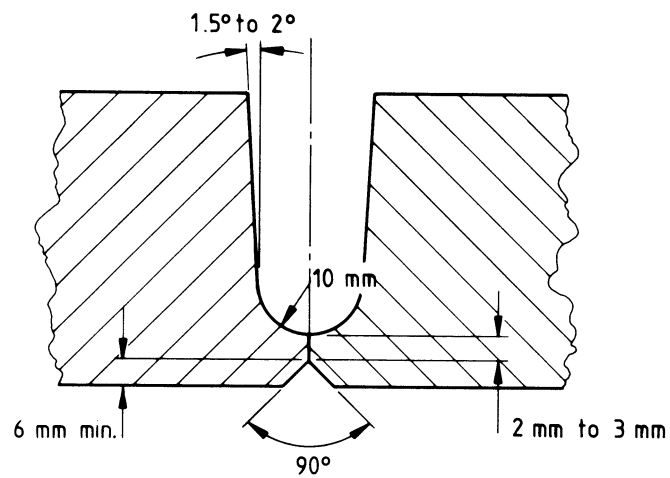

(b) For use with submerged-arc welding and manual metal-arc welding for back seal weld

Figure 16 — Typical butt joint preparations using a narrow gap

D.2 Typical edge shapes for branch connections are shown in Figure 17 to Figure 22.

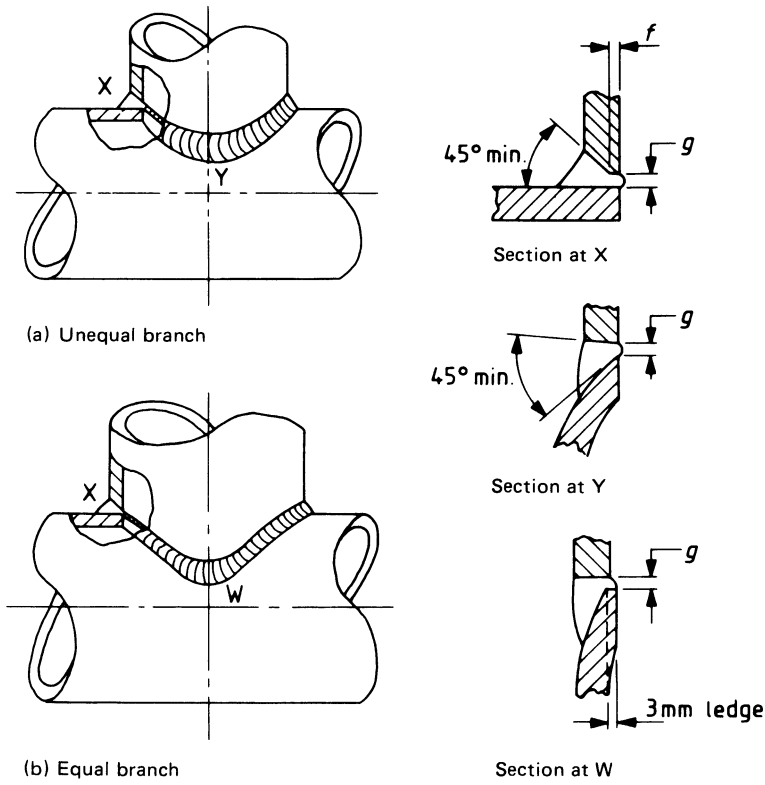

<i>g</i>	<i>f</i>
mm	mm
2.5 ± 1.0	1.5 ± 1.0

Figure 17 — Typical preparation and assembly of set-on right angle branches without backing

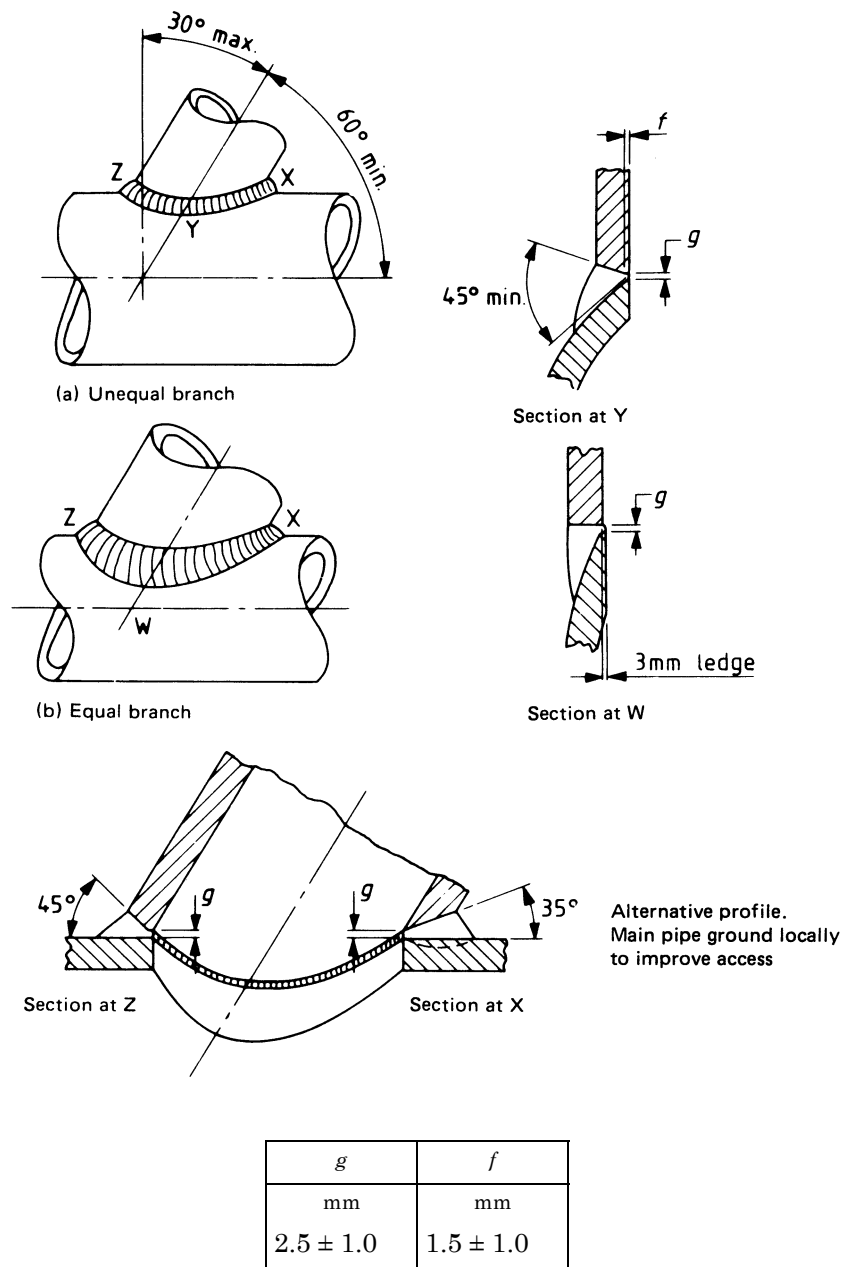
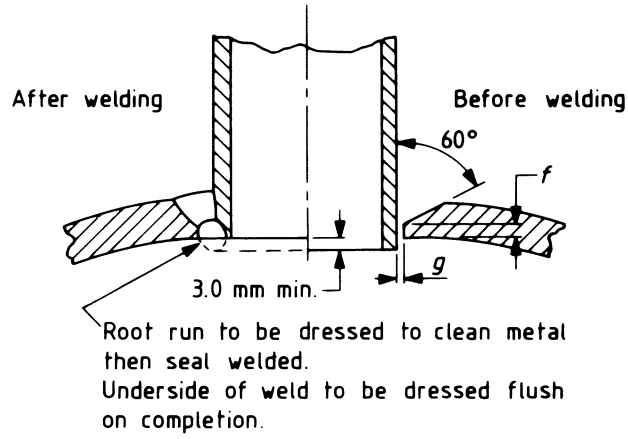
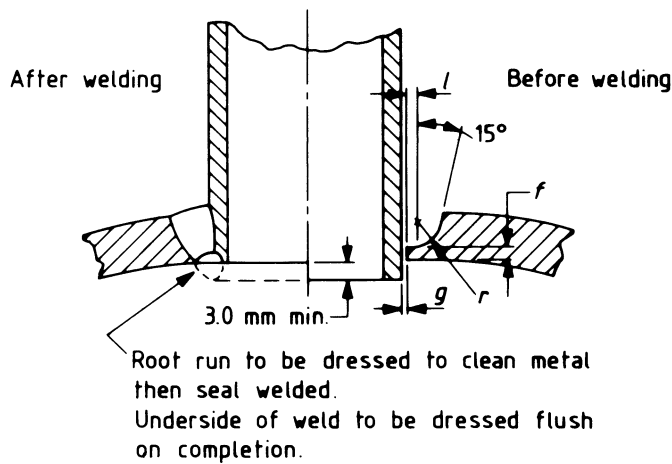

Figure 18 — Typical preparation and assembly of set-on sloping branches without backing



(a) Single-bevel preparation



(b) Single-J preparation

Figure	g	f (max.)	l	r
	mm	mm	mm	mm
(a)	1.0	2.5	—	—
(b)	1.0	3.0	3.0	5.0

Figure 19 — Typical preparation and assembly of set-in branches (access from inside pipe)

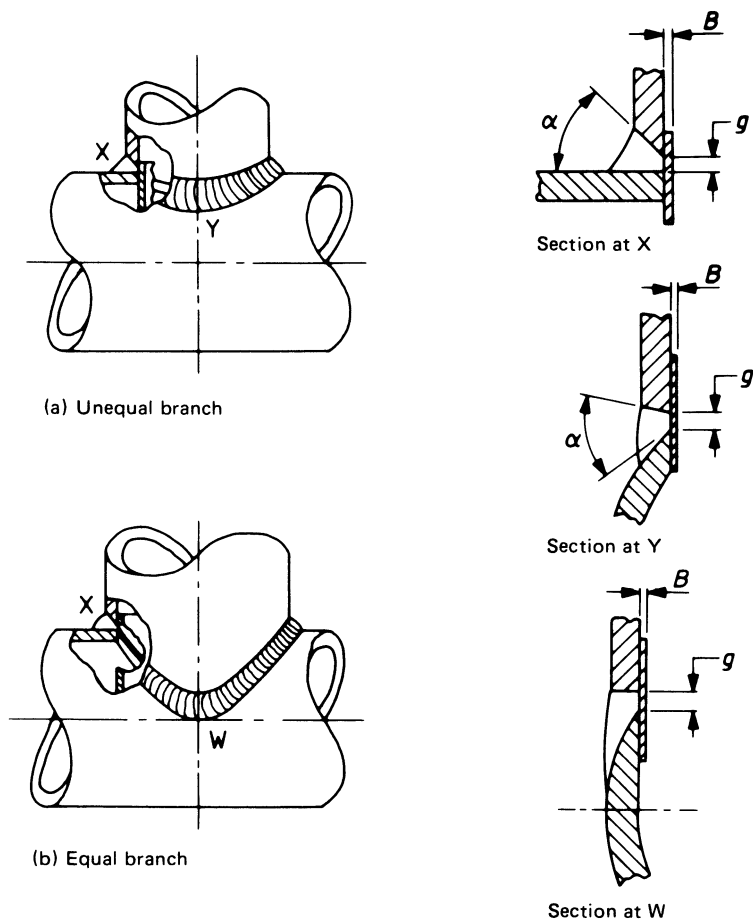

α	g	B
	mm	mm
15° to 20°	8.0 to 10.0	3.0 to 5.0

NOTE 1 Root run in each corner in all cases. The backing ring is to be removed after welding.

NOTE 2 A recessed backing ring may be necessary in some cases.

Figure 20 — Typical preparation and assembly of set-on right angle branches with temporary backing

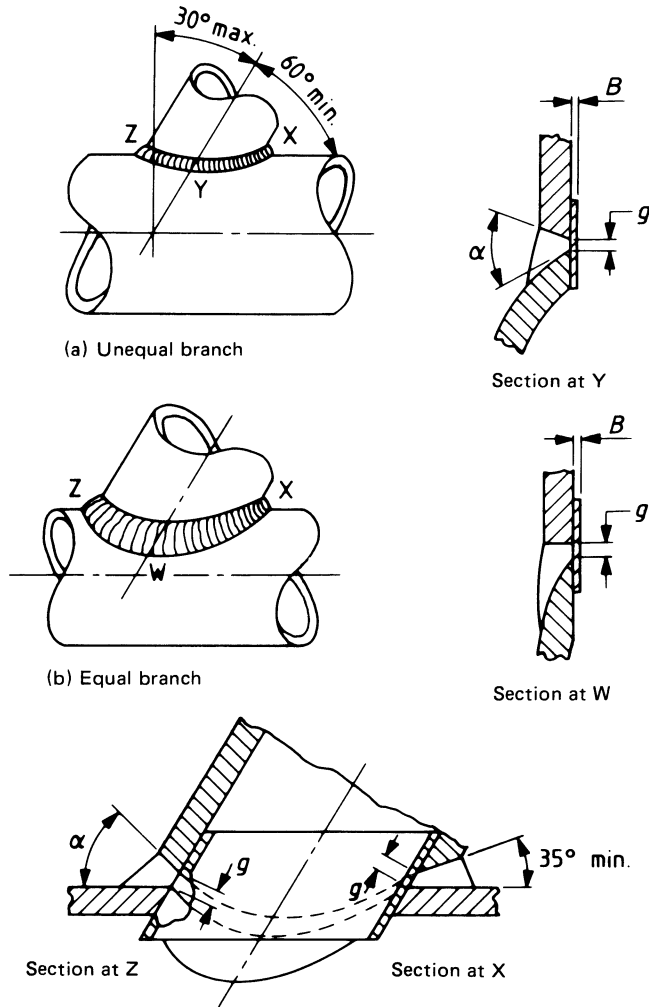

α	g	B
	mm	mm
15° to 20°	8.0 to 10.0	3.0 to 5.0

NOTE 1 Root run in each corner in all cases. The backing ring is to be removed after welding.

NOTE 2 A recessed backing ring may be necessary in some cases.

Figure 21 — Typical preparation and assembly of set-on sloping branches with temporary backing

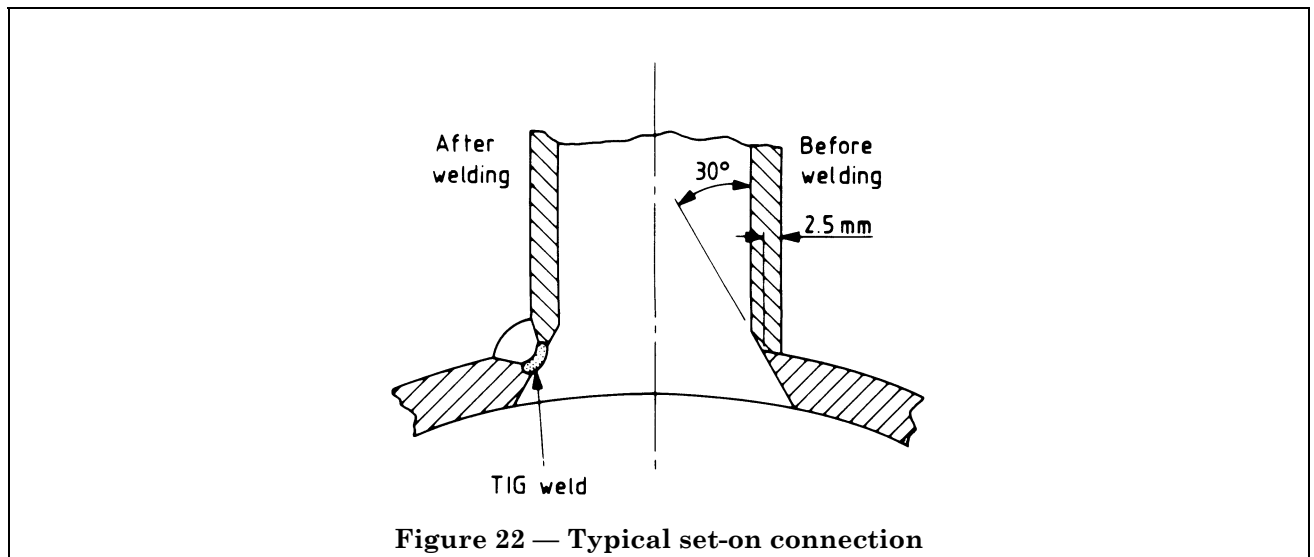

D.3 Typical forms of small bore connections are shown in Figure 23 and guidance on their use is given below.

Figure 23 (a). This type of connection is made from forged or rolled bar and is bored to finished or tapping size after welding. It is suitable for all sizes of main pipe.

Figure 23 (b). This type of connection is made from screwed sockets, couplings or tube shaped to suit the bore of the main pipe.

It is recommended that this type of connection should only be used where it is located near the open end of a pipe and only on pipe of such bore as will allow access for the removal of any excess penetration of weld metal at the root of the weld by grinding, filing or machining.

Figure 23 (c). This type of connection is made from tube, or half couplings or equivalent, and is suitable for all sizes of main pipe. It is bored to finished or tapping size after welding and to remove the root penetration of the weld.

Figure 23 (d). This small bore branch connection is only suitable where the main pipe has a bore at least five times the bore of the branch. A flat is machined on the outside of the main pipe to receive the prepared end of the branch.

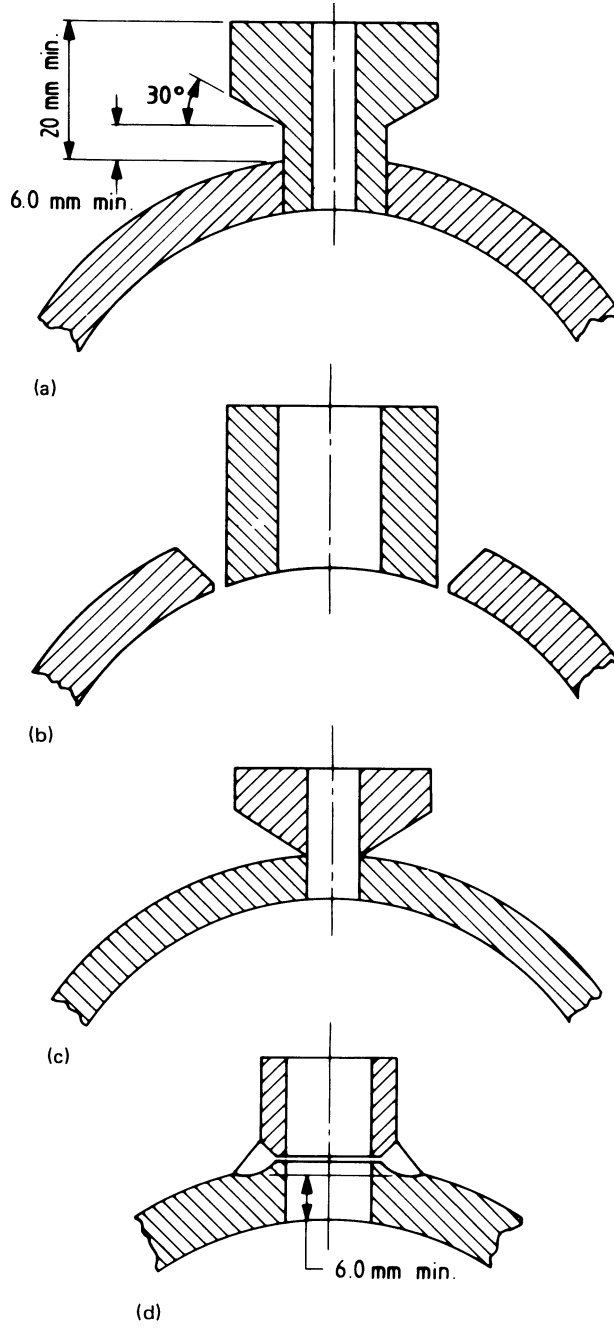
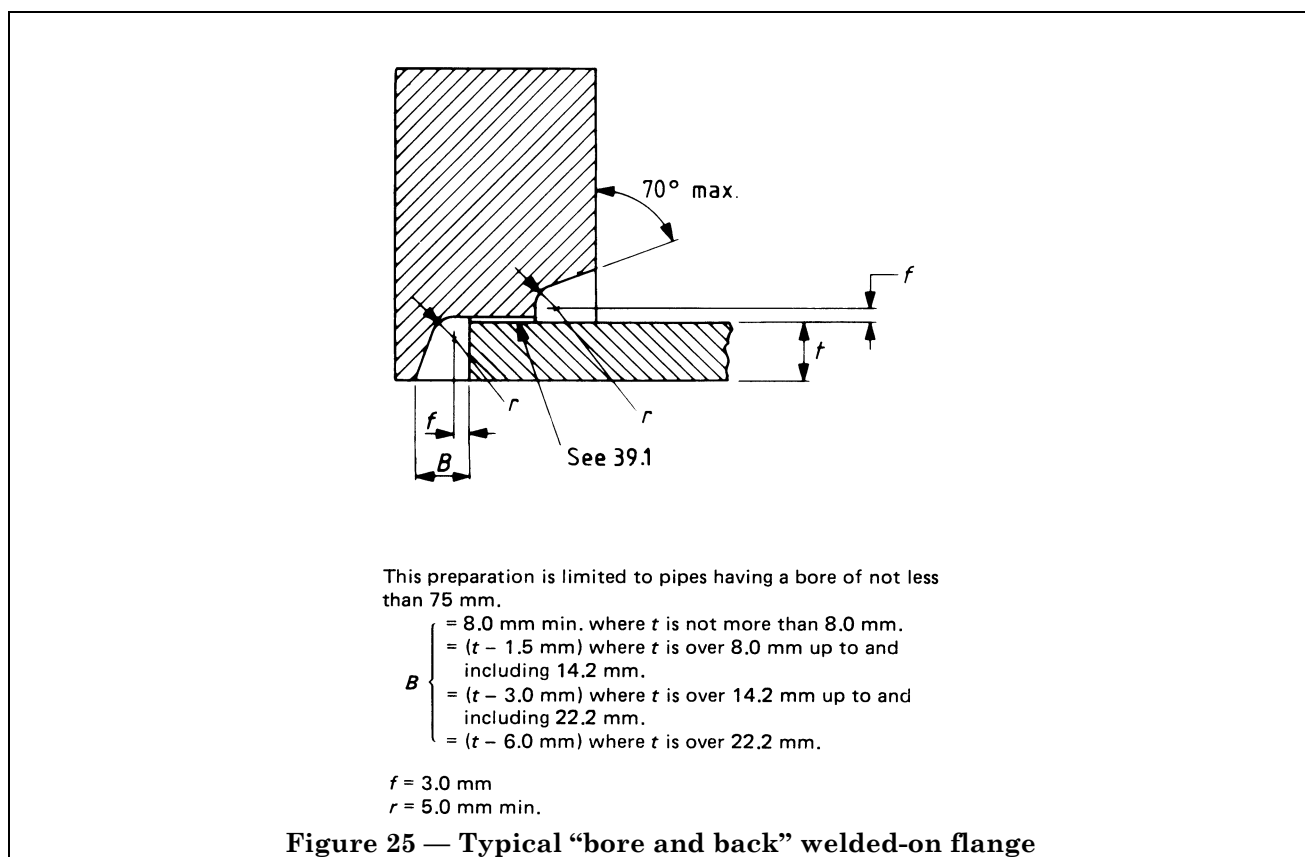
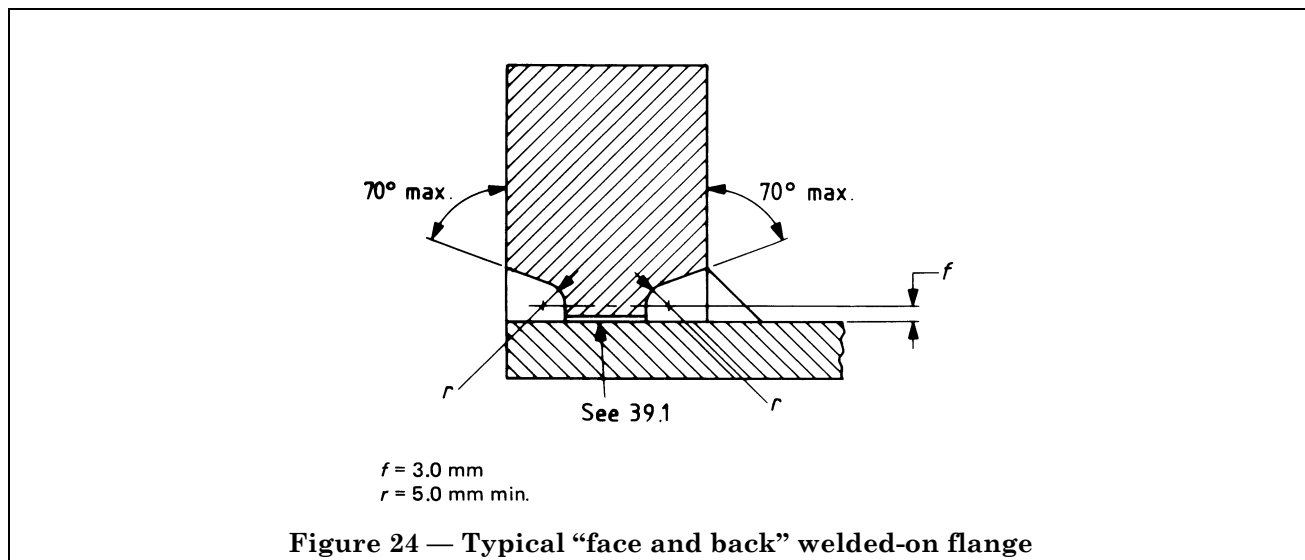
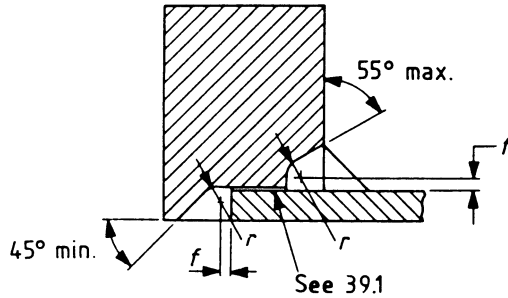

Figure 23 — Typical small bore connections

D.4 Typical weld preparations for plate flanges are shown in Figure 24 to Figure 32.





$f = 3.0 \text{ mm}$
 $r = 5.0 \text{ mm min.}$

This preparation is limited to pipes having a bore of not less than 75 mm.

Figure 26 — Typical “bore and back” welded-on flange for positional welding

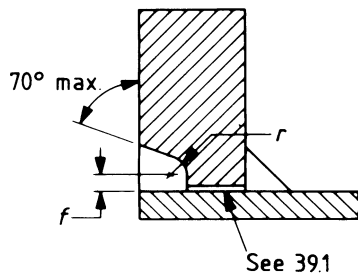

$f = 3.0 \text{ mm}$
 $r = 5.0 \text{ mm min.}$

Figure 27 — Typical “face and fillet” welded-on flange

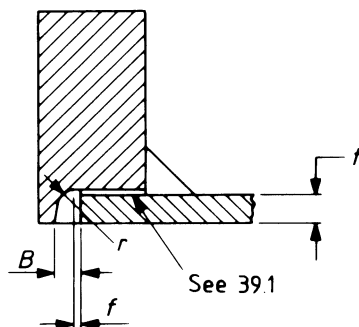

This preparation is limited to pipes having a bore of not less than 75 mm.

$B \begin{cases} = 8.0 \text{ mm minimum where } t \text{ is not more than } 8.0 \text{ mm.} \\ = (t - 1.5 \text{ mm}) \text{ where } t \text{ is over } 8.0 \text{ mm up to and including } 14.2 \text{ mm.} \\ = (t - 3.0 \text{ mm}) \text{ where } t \text{ is over } 14.2 \text{ mm up to and including } 22.2 \text{ mm.} \\ = (t - 6.0 \text{ mm}) \text{ where } t \text{ is over } 22.2 \text{ mm.} \end{cases}$

$f = 3.0 \text{ mm}$
 $r = 5.0 \text{ mm min.}$

Figure 28 — Typical “bore and fillet” welded-on flange

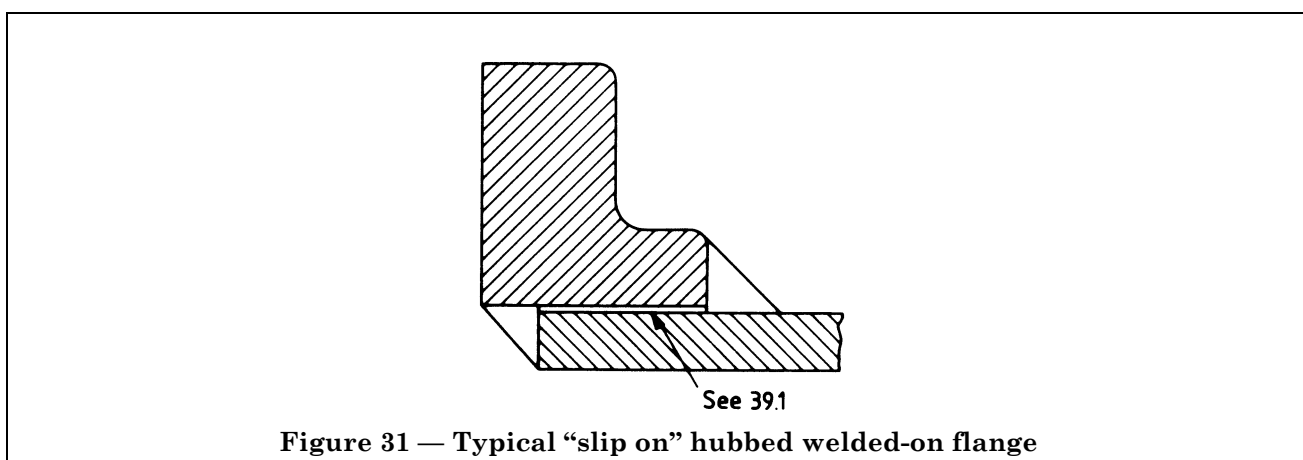
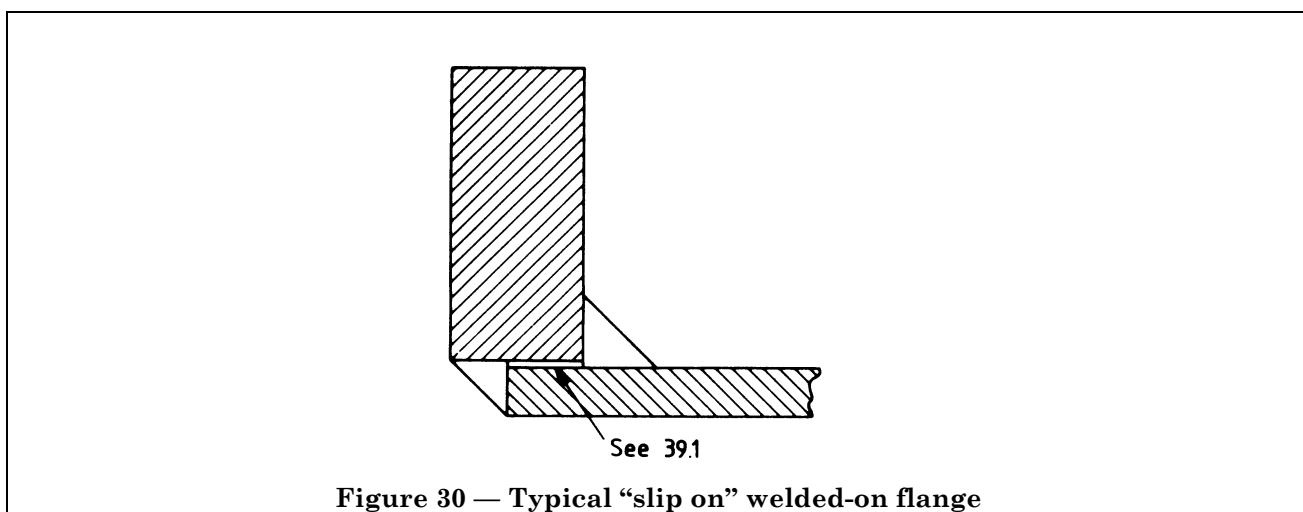
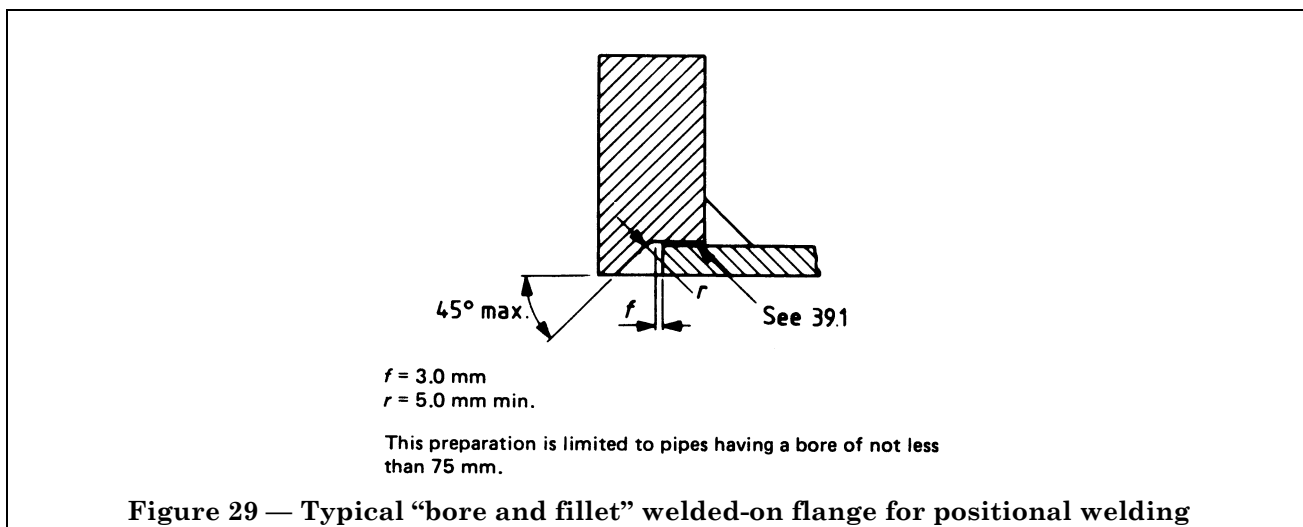

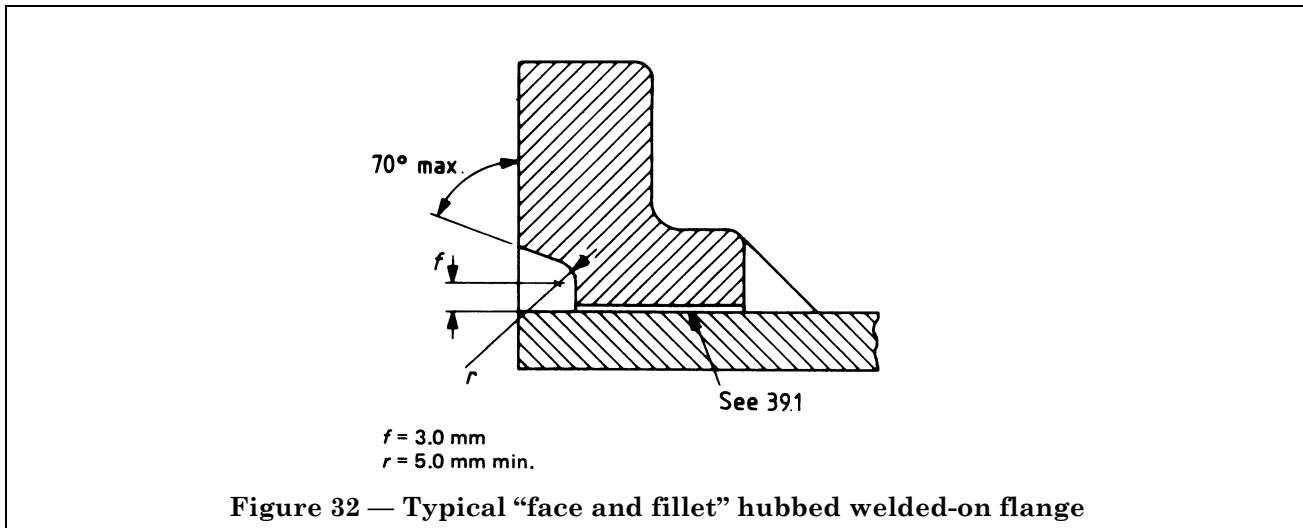

Appendix E Guidance on welding transition joints between ferritic steel and austenitic stainless steel

E.1 Introduction

E.1.1 Where it is necessary in a pipework system to join different types of steel, this can be successfully achieved by the use of a welded joint. Careful consideration of all design factors, e.g. design strength, corrosion behaviour and fatigue resistance, should be used to decide the location of transition joints.

E.1.2 Generally, no special weld preparations are required and welds can be made using the pre-heating conditions for the ferritic alloy. Welds have been successfully made in pipe of thicknesses from 3 mm to 80 mm and all diameters. Special welding tests may be necessary to demonstrate the successful manufacture and use of a transition joint for any particular application.

E.1.3 A range of filler metals is available and unless special operating conditions are required, such as high temperature strength or low temperature toughness, the normal welding procedure tests in accordance with BS EN 288-3 are adequate to demonstrate the acceptability of any particular material combination. Some special consideration may have to be given to the performance of weld metal/heat-affected zone interfaces when bend tests as required by BS EN 288-3 are carried out, as a failure in these tests may not be indicative of any weakness in the use of the joint in service. The weld metal/heat-affected zone interfaces may also require careful consideration if the joint is intended for high temperature service, since some weakening may occur due to either sensitization to intergranular failure or loss of alloying elements causing loss of mechanical strength. The designer should examine whether additional tests are necessary to substantiate operation in service.

E.1.4 For all transition joints the designer should also evaluate the need for and temperature of any post-weld heat treatment, as they may also have an effect on the long term reliability of such joints.

E.1.5 The inspection and testing of austenitic stainless/ferritic steel joints may also require individual procedures both in manufacture and service because not all available methods of non-destructive testing will be suitable for use on such weldments.

E.2 Materials

Parent metals are those covered by clause 3 and BS 4677.

E.3 Methods of making transition joints

E.3.1 Normal butt joint

A weld preparation of conventional type is filled with austenitic stainless steel or nickel base alloy weld metal. The austenitic stainless steel weld metal should preferably be of an over-alloyed type such as 23 Cr 12 Ni to allow for dilution rather than a grade matching the stainless steel parent material.

E.3.2 Buttered preparation

When it is necessary to prevent carbon migration from the ferritic material, it is usual to butter the preparation with nickel base weld metal and then re-prepare the fusion faces for welding.

Alternatively the butter layer can be of a niobium stabilized austenitic stainless steel or a very low carbon version of the ferritic parent material.

E.3.3 Transition inserts

E.3.3.1 Ungraded. In certain high temperature situations instead of a single joint between the two parent metals it may be considered advisable to introduce an insert of compatible material, usually austenitic stainless steel or nickel base alloy, with a coefficient of expansion between that of the two parent metals. Two transition welds would be required. The transition joint can be prefabricated with cuff extensions prior to insertion in the final assembly.

E.3.3.2 Graded. Proprietary insert sections are available, produced by consumable remelting of composite electrodes, where material matching one of the parent metals changes throughout its length to material matching the other parent metal. In addition to being better able to withstand the effects of thermal gradients, this type of joint allows welds in matching materials and is suitable for creep and non-creep conditions. The minimum length of insert should take account of inspection requirements and possible local post-weld heat treatment.

E.4 Joint preparation

Joint preparations should be based on those given in Appendix D or BS 4677.

E.5 Weld metal

E.5.1 Non-creep service conditions

For a transition weld joining a ferritic material, other than 3½ Ni and 9 Ni, to austenitic stainless steel, weld metal such as produced by electrodes complying with class 23.12 of BS 2926 or wire complying with type 309S94 of BS 2901-2 is recommended or nickel base alloy weld metal such as from wires complying with type NA 35 or NA 43 of BS 2901-5. For 3½ Ni and 9 Ni to austenitic stainless materials, nickel base alloy weld metal is recommended. When nickel base alloy weld metal is used for buttering, the fill-up should also be with nickel base alloy.

E.5.2 Creep service conditions

Nickel base alloy weld metal such as from wires complying with type NA 35 or NA 43 of BS 2901-5 is recommended. This does not preclude the use of austenitic stainless steel weld metal providing sufficient evidence of suitability for service conditions is available. Nickel base alloy weld metal should be acceptable at both ends of ungraded inserts.

E.6 Selection and control of welding processes

TIG welding and manual metal-arc welding may be readily adopted for nickel base alloy or austenitic consumables of both types. Submerged-arc welding may be adopted providing the ferritic parent metal is first buttered with weld metal of the 23 Cr 12 Ni type using TIG welding or manual metal-arc welding. Nickel base alloys are not recommended for use with submerged-arc welding.

Other processes may be used provided there is sufficient evidence for their adoption.

E.7 Purging

Purging should be in accordance with clause 14 or BS 4677.

E.8 Pre-heating, interpass temperature and post-weld heat treatment

E.8.1 Pre-heating

Generally, pre-heating should be in accordance with clauses 18 and 23 for the ferritic parent material. However, because the low diffusion rate of hydrogen in austenitic stainless and nickel base weld metal reduces hydrogen concentration in the ferritic heat-affected zone, a lower temperature may be acceptable.

E.8.2 Post-weld heat treatment

Generally, when it is necessary to temper the heat-affected zone of the ferritic material, the requirements of clauses 22 and 23 should be met. However, metallurgical damage to the austenitic stainless steel could result from such a heat treatment unless the ferritic side of the joint is post-weld heat treated separately; this can be achieved by the use of an insert or buttering.

E.9 Further metallurgical considerations

E.9.1 Carbon migration

Weakening of the ferritic side of the joint can occur due to carbon diffusion during welding, post-weld heat treatment or operation in the creep range (see **E.3.2**).

E.9.2 Dilution problems

High dilution (above 30 %) of filler materials by parent metals is undesirable when either austenitic or nickel alloy consumables are used.

If the dilution is known, the Schaeffler diagram or the Delong diagram may be used to determine the constitution of the weld metal when austenitic stainless consumables are used. A weld metal consisting of austenite with 5 % to 10 % delta-ferrite will generally give satisfactory results.

For dilutions of less than 30 %, consumables of the 23 Cr 12 Ni or nickel alloy types would normally produce acceptable weld metal compositions.

Root runs, where dilution is likely to be most severe, should not be made without filler wire or a consumable insert unless the whole root area is to be removed before the joint is put into service.

E.10 Non-destructive testing

E.10.1 Surface inspection

Liquid penetrant testing is suitable for surface examination of austenitic stainless/ferritic steel joints.

NOTE Austenitic stainless steel is not ferro-magnetic, therefore magnetic particle testing is not suitable.

E.10.2 volumetric testing

E.10.2.1 Radiography may be used but care is necessary in the application of the technique to allow for different absorption characteristics of the various materials. In addition, interpretation of radiographs may be complicated by the diffraction patterns occasionally generated by austenitic stainless and nickel base weld metals.

E.10.2.2 Ultrasonic examination of transition joints is possible but attenuation and beam deflection can influence signals to such an extent that misleading information is given. Procedures should be proven on joints made to the same manufacturing procedure and similar geometry to the production joints.

E.11 General comments and recommendations

E.11.1 Branch welds between austenitic stainless and ferritic steels are not recommended.

E.11.2 Ferritic steel attachments to austenitic stainless steel pipes operating in the creep range are not recommended.

E.11.3 Attachment welds between dissimilar steels should receive the same consideration as butt welds.

E.11.4 Joint alignment for welding should preferably be achieved without the use of welded bridge pieces, particularly where high alloy ferritic steels are involved. Where this is not possible it may be advisable to make special bridge pieces enabling ferritic to ferritic steel welds to be made on one side of the joint and austenitic stainless to austenitic stainless steel to be made on the other side (see clause **13**).

E.11.5 Root runs should preferably be made by TIG welding using filler wire or a consumable insert.

E.11.6 When it is necessary to remove the root area to achieve the desired quality, a machining allowance will be required.

E.11.7 Transition joints between austenitic stainless and ferritic steel pipes should preferably be made as a sub-item which can be welded, machined, post-weld heat treated when required, and fully inspected before final assembly welds are made in like materials.

Appendix F Guidance on the use of methods of non-destructive testing

F.1 Radiographic examination

Radiography has the obvious advantage of providing a permanent record of defects on film. However, while it is particularly suitable for detecting the volumetric defects such as porosity or slag inclusions, it is incapable of detecting planar defects such as lack of side fusion or weld metal cracks unless by chance the beam is aligned within $\pm 5^\circ$ of the plane of the defect.

F.2 Ultrasonic examination

Ultrasonic examination is particularly suitable for detecting planar or crack-like defects such as lack of side fusion and tightly closed root cracks. It can also size these defects depending upon the particular technique employed and subject to certain limitations such as surface condition and pipe geometry. As a general rule, it can be stated that ultrasonic examination is not capable of sizing any defect having a dimension less than 3 mm.

F.3 Internal defects

Radiography has less capability for the detection of significant types of defects, e.g. planar defects than ultrasonic examination. Ultrasonic examination provides a capability for the location of defects in the through-thickness direction and is also capable of measuring defect height and width. Radiography can measure width more accurately than ultrasonic examination but it cannot readily determine the position of planar-type defects or measure height reliably.

If ultrasonic examination is chosen, care should be taken to ensure that techniques which are too sensitive and which may lead to the unnecessary repair of defects of very minor cross section are not employed. A danger in ultrasonic examination is that the use of sensitive techniques can result in indications of length much in excess of the indications which would be obtained by radiography.

Special techniques and procedures are required for the use of ultrasonic examination on austenitic welds and the detection capabilities are restricted as compared with those associated with ferritic welds.

Radiography should be used normally for the examination of transition welds between austenitic and ferritic steels.

Radiography is not normally suitable for the examination of branch, nozzle or stub welds but in some instances may be more suitable than ultrasonic examination for the inspection of butt welds to which access for ultrasonic examination is limited by local geometry.

F.4 Surface defects

Magnetic particle and penetrant examination do not indicate the depth of surface defects; their purpose is to ensure that no unacceptable surface defects are present. The choice of method depends upon material; magnetic methods are quicker and generally more effective for ferritic steels but are unsuitable for austenitic steels, for which penetrant methods are employed.

Publications referred to

- BS 638, *Arc welding power sources, equipment and accessories.*
- BS 806, *Specification for design and construction of ferrous piping installations for and in connection with land boilers.*
- BS 1560, *Circular flanges for pipes, valves and fittings (Class designated).*
- BS 1560-3, *Steel, cast iron and copper alloy flanges.*
- BS 1560-3.1, *Specification for steel flanges.*
- BS 1640, *Specification for steel butt-welding pipe fittings for the petroleum industry.*
- BS 1640-3, *Wrought carbon and ferritic alloy steel fittings. Metric units.*
- BS 1821, *Specification for class I oxy-acetylene welding of ferritic steel pipework for carrying fluids.*
- BS 1965, *Specification for butt-welding pipe fittings for pressure purposes.*
- BS 1965-1, *Carbon steel.*
- BS 2493, *Specification for low alloy steel electrodes for manual metal-arc welding.*
- BS 2640, *Specification for class II oxy-acetylene welding of carbon steel pipework for carrying fluids³⁾.*
- BS 2901, *Specification for filler rods and wires for gas-shielded arc welding.*
- BS 2901-1, *Ferritic steels.*
- BS 2901-2, *Austenitic stainless steels.*
- BS 2901-5, *Nickel and nickel alloys.*
- BS 2910, *Methods for radiographic examination of fusion welded circumferential butt joints in steel pipes.*
- BS 2926, *Specification for chromium and chromium-nickel steel electrodes for manual metal-arc welding.*
- BS 2971, *Specification for class II arc welding of carbon steel pipework for carrying fluids³⁾.*
- BS 3059, *Specification for steel boiler and superheater tubes.*
- BS 3059-1, *Low tensile carbon steel tubes without specified elevated temperature properties.*
- BS 3059-2, *Carbon, alloy and austenitic stainless steel tubes with specified elevated temperature properties.*
- BS 3601, *Specification for steel pipes and tubes for pressure purposes: carbon steel with specified room temperature properties.*
- BS 3602, *Specification for steel pipes and tubes for pressure purposes: carbon and carbon manganese steel with specified elevated temperature properties.*
- BS 3602-1, *Seamless, electric resistance welded and induction welded tubes.*
- BS 3602-2, *Submerged arc welded tubes.*
- BS 3603, *Specification for steel pipes and tubes for pressure purposes: carbon and alloy steel with specified low temperature properties.*
- BS 3604, *Specification for steel pipes and tubes for pressure purposes: ferritic alloy steel with specified elevated temperature properties.*
- BS 3606, *Specification for steel tubes for heat exchangers.*
- BS 3799, *Specification for steel pipe fittings, screwed and socket-welding for the petroleum industry.*
- BS 3923, *Ultrasonic examination of welds.*
- BS 3923-1, *Methods for manual examination of fusion welds in ferritic steels.*
- BS 3971, *Specification for image quality indicators for industrial radiography (including guidance on their use).*
- BS 4105, *Specification for liquid carbon dioxide, industrial.*
- BS 4204, *Specification for flash welding of steel tubes for pressure applications³⁾.*

³⁾ Referred to in the foreword only.

- BS 4504, *Circular flanges for pipes, valves and fittings (PN designated).*
- BS 4504-3, *Steel, cast iron and copper alloy flanges.*
- BS 4504-3.1, *Specification for steel flanges.*
- BS 4504-3.2, *Specification for cast iron flanges.*
- BS 4677, *Specification for arc welding of austenitic stainless steel pipework for carrying fluids.*
- BS 4870, *Specification for approval testing of welding procedures.*
- BS 4870-1, *Fusion welding of steel (withdrawn).*
- BS 4871, *Specification for approval testing of welders working to approved welding procedures.*
- BS 4871-1, *Fusion welding of steel (withdrawn).*
- BS 5289, *Code of practice for visual inspection of fusion welded joints.*
- BS 6072, *Methods for magnetic particle flaw detection.*
- BS 6084, *Method of test for comparison of prefabrication primers by porosity rating in arc welding.*
- BS 6443, *Method for penetrant flaw detection.*
- BS 6693, *Diffusible hydrogen.*
- BS 6693-2, *Method for determination of hydrogen in manual metal-arc weld metal.*
- PD 6493, *Guidance on some methods for the derivation of acceptance levels for defects in fusion welded joints.*
- BS EN 287-1, *Approval testing of welders for fusion welding — Part 1: Steels.*
- BS EN 287-2, *Approval testing of welders for fusion welding — Part 2: Aluminium and aluminium alloys.*
- BS EN 288-1, *Specification and approval of welding procedures for metallic materials — Part 1: General rules for fusion welding.*
- BS EN 288-2, *Specification and approval of welding procedures for metallic materials — Part 2: Welding procedures specification for arc welding.*
- BS EN 288-3, *Specification and approval of welding procedures for metallic materials — Part 1: Welding procedure tests for the arc welding of steels.*
- BS EN 499, *Welding consumables — Covered electrodes for manual metal arc welding of non alloy and fine grain steels — Classification.*
- BS EN 440, *Welding consumables — Wire electrodes and deposits for gas shielded arc welding of non alloy and fine grain steels — Classification.*
- BS EN 439, *Welding consumables — Shielding gases for arc welding and cutting — Classification.*
- BS EN 30012-1, *Quality assurance requirements for measuring equipment — Metrological confirmation system for measuring equipment.*
- BS EN ISO 9000, *Quality management and quality assurance*⁴⁾.
- ASTM A106, *Standard specification for seamless carbon steel pipe for high temperature service.*
- ASTM A333, *Standard specification for seamless and welded steel pipe for low temperature service.*
- ASTM A335, *Standard specification for seamless ferritic alloy steel pipe for high temperature service.*
- DIN 17173, *Seamless tubes made from steels with low temperature toughness. Technical conditions of delivery.*
- DIN 17174, *Welded tubes made from steels with low temperature toughness. Technical conditions of delivery.*
- DIN 17175, *Seamless tubes of heat resistant steels. Technical conditions of delivery.*
- DIN 17177, *Electric pressure welded steel tubes for elevated temperatures. Technical conditions of delivery.*
- Vd TÜV 377/2, *Weldable creep resistant structural steel.*

⁴⁾ Referred to in foreword only.

BSI — British Standards Institution

BSI is the independent national body responsible for preparing British Standards. It presents the UK view on standards in Europe and at the international level. It is incorporated by Royal Charter.

Revisions

British Standards are updated by amendment or revision. Users of British Standards should make sure that they possess the latest amendments or editions.

It is the constant aim of BSI to improve the quality of our products and services. We would be grateful if anyone finding an inaccuracy or ambiguity while using this British Standard would inform the Secretary of the technical committee responsible, the identity of which can be found on the inside front cover. Tel: 020 8996 9000. Fax: 020 8996 7400.

BSI offers members an individual updating service called PLUS which ensures that subscribers automatically receive the latest editions of standards.

Buying standards

Orders for all BSI, international and foreign standards publications should be addressed to Customer Services. Tel: 020 8996 9001. Fax: 020 8996 7001.

In response to orders for international standards, it is BSI policy to supply the BSI implementation of those that have been published as British Standards, unless otherwise requested.

Information on standards

BSI provides a wide range of information on national, European and international standards through its Library and its Technical Help to Exporters Service. Various BSI electronic information services are also available which give details on all its products and services. Contact the Information Centre. Tel: 020 8996 7111. Fax: 020 8996 7048.

Subscribing members of BSI are kept up to date with standards developments and receive substantial discounts on the purchase price of standards. For details of these and other benefits contact Membership Administration. Tel: 020 8996 7002. Fax: 020 8996 7001.

Copyright

Copyright subsists in all BSI publications. BSI also holds the copyright, in the UK, of the publications of the international standardization bodies. Except as permitted under the Copyright, Designs and Patents Act 1988 no extract may be reproduced, stored in a retrieval system or transmitted in any form or by any means – electronic, photocopying, recording or otherwise – without prior written permission from BSI.

This does not preclude the free use, in the course of implementing the standard, of necessary details such as symbols, and size, type or grade designations. If these details are to be used for any other purpose than implementation then the prior written permission of BSI must be obtained.

If permission is granted, the terms may include royalty payments or a licensing agreement. Details and advice can be obtained from the Copyright Manager. Tel: 020 8996 7070.