

# Stabilized materials for civil engineering purposes —

**Part 2: Methods of test for  
cement-stabilized and lime-stabilized  
materials**

# Committees responsible for this British Standard

The preparation of this British Standard was entrusted by the Road Engineering Standards Policy Committee (RDB/-) to Technical Committee RDB/9, upon which the following bodies were represented:

British Aggregate Construction Materials Industries  
 British Cement Association  
 British Civil Engineering Test Equipment Manufacturers' Association  
 British Coal Corporation  
 County Surveyors' Society  
 Department of the Environment (Property Services Agency)  
 Department of the Environment (Building Research Establishment)  
 Department of Transport  
 Federation of Civil Engineering Contractors  
 Institution of Civil Engineers  
 Institution of Highways and Transportation  
 Institution of Structural Engineers  
 Rothamsted Experimental Station  
 Society of Chemical Industry

The following bodies were also represented in the drafting of the standard, through subcommittees and panels:

Association of Consulting Engineers  
 Refined Bitumen Association Ltd.  
 Co-opted members

This British Standard, having been prepared under the direction of the Road Engineering Standards Policy Committee, was published under the authority of the Board of BSI and comes into effect on

© BSI 05-1999

First published as BS 1924  
 June 1953

Second edition February 1957

Third edition December 1967

Fourth edition April 1975

Fifth edition published as  
 BS 1924-2 October 1990

The following BSI references relate to the work on this standard:

Committee reference RDB/9

Draft for comment 88/14800 DC

ISBN 0 580 18498 6

## Amendments issued since publication

Amd. No.	Date of issue	Comments

# Contents

	Page
Committees responsible	Inside front cover
Foreword	ii
<hr/>	
Section 1. Scope, definitions and classification tests	
1.1 Scope	1
1.2 Definitions	1
1.3 Determination of moisture content	1
1.3.1 Principle	1
1.3.2 Sampling	1
1.3.3 Oven-drying method (Definitive method)	1
1.3.4 Sand-bath method	2
1.3.5 Microwave oven method (Subsidiary method for fine grained materials)	3
1.3.6 Calcium carbide method (Subsidiary method)	4
1.3.7 Nuclear gauge method (for on site testing only)	4
1.3.8 Test report	4
1.4 Determination of effect of the stabilizer on plasticity properties	5
1.4.1 Principle	5
1.4.2 Apparatus	5
1.4.3 Sample preparation	5
1.4.4 Determination of the plastic limit	5
1.4.5 Determination of the liquid limit	7
1.4.6 Derivation of the plasticity index	8
1.4.7 Test report	8
1.5 Determination of degree of pulverization	9
1.5.1 Principle	9
1.5.2 Apparatus	9
1.5.3 Procedure	9
1.5.4 Calculations and expression of results	9
1.5.5 Test report	9
<hr/>	
Section 2. Compaction related tests	
2.1 Determination of the dry density/moisture content relation	10
2.1.1 Principle	10
2.1.2 Types of test	10
2.1.3 Method using 2.5 kg rammer	10
2.1.4 Method using 4.5 kg rammer	13
2.1.5 Method using vibratory compaction (Definitive method)	14
2.1.6 Method using vibratory compaction (Subsidiary method)	17
2.1.7 Test report	19
2.2 Determination of the moisture condition value (MCV)	19
2.2.1 Principle	19
2.2.2 Sampling	19
2.2.3 Procedure for determination of the MCV	20
2.2.4 Procedure for determination of the MCV/moisture content relation	20
<hr/>	
Section 3. In-situ density tests	
3.1 Nuclear moisture/density gauges	21
3.2 Sampling	21
3.3 Sand replacement method	21
3.4 Core-cutter method (for unhardened fine-grained materials)	24

	Page	
3.5	Immersion in water method	25
3.6	Water displacement method	27
3.7	Nuclear gauge method	30
3.8	Test report	36
<hr/>		
Section 4. Strength and durability tests		
4.1	Determination of the compressive strength of cylindrical specimens	5
4.2	Determination of the compressive strength of cubic specimens	40
4.3	Determination of the effect of immersion in water on the compressive strength	43
4.4	Determination of the tensile splitting strength	45
4.5	Laboratory determination of the California Bearing Ratio	46
4.6	Determination of the in-situ California Bearing Ratio	50
4.7	Determination of the vertical deformation characteristics by the plate loading test	51
4.8	Determination of the frost-heave	51
<hr/>		
Section 5. Chemical tests		
5.1	Determination of the cement content of cement-stabilized materials	53
5.2	Determination of the lime content of lime-stabilized materials	56
5.3	Determination of the in-situ pH of lime- or cement-stabilized materials as a guide to the degree of carbonation	58
5.4	Determination of the initial consumption of lime	59
<hr/>		
Appendix A Typical data and calculation forms		88
<hr/>		
Figure 1	— Details of cone for the liquid limit test	62
Figure 2	— Mould for the compaction test (1 L mould)	63
Figure 3	— 2.5 kg rammer for the compaction test	64
Figure 4	— 4.5 kg rammer for the compaction test	65
Figure 5	— Compaction mould and anvil for the vibratory compaction test	66
Figure 6	— Compaction rig assembly	67
Figure 7	— Tampers for the vibrating hammer test	68
Figure 8	— Two methods of transmission with nuclear surface density gauge	69
Figure 9	— Small pouring cylinder for the determination of the density of fine- and medium-grained materials	70
Figure 10	— Calibrating container for use with the small pouring cylinder	71
Figure 11	— Large pouring cylinder for the determination of the density of medium- and coarse-grained materials	72
Figure 12	— Calibrating container for use with the large pouring cylinder	73
Figure 13	— Core-cutter apparatus for in-situ density determination of fine-grained materials	74
Figure 14	— Diagrammatic representation of the cradle and supporting frame for determination of density by the immersion-in-water method	75
Figure 15	— Apparatus for the determination of density of stabilized material by water displacement (fine- and medium-grained materials)	75
Figure 16	— Apparatus for the determination of density of stabilized material by water displacement (coarse-grained materials)	76
Figure 17	— Tapered cylindrical mould with plugs for preparation of specimens for the compressive strength test (fine-grained materials)	77
Figure 18	— Plunger and displacing collar for use with tapered cylindrical mould of Figure 17	77

	Page
Figure 19 — Tapered cylindrical mould with plugs for preparation of specimens for the compressive strength test (medium-grained materials)	78
Figure 20 — Plunger and displacing collar for use with tapered cylindrical mould of Figure 19	79
Figure 21 — Tamper with spacing collar, for use with a vibrating hammer, for preparation of cubic specimens made up to a predetermined dry density for the compressive strength test	80
Figure 22 — Rammer for preparation of cubic specimens compacted to a constant compactive effort for the compressive strength test	81
Figure 23 — Suitable jigs for the tensile splitting test	82
Figure 24 — Plane of loading	83
Figure 25 — Cylindrical mould for the determination of the California Bearing Ratio	83
Figure 26 — Plug and collar for use with the cylindrical mould for the determination of the California Bearing Ratio	84
Figure 27 — General arrangement of apparatus for the CBR test	85
Figure 28 — Apparatus for measuring the swelling of a specimen during soaking for the CBR test	86
Figure 29 — Force/penetration curve obtained in CBR test showing method of correction	87
Table 1 — Minimum mass of test portions	1
Table 2 — Standard forces for 100 % CBR	50
Table 3 — CBR values	50
Table 4 — Typical values of $Z$	56
Publications referred to	Inside back cover

# Foreword

This Part of BS 1924 has been prepared under the direction of the Road Engineering Standards Policy Committee. It is Part 2 of a revision in two Parts of BS 1924:1975, which is now withdrawn.

The two Parts of BS 1924 are:

- *Part 1: General requirements, sampling, sample preparation and tests on materials before stabilization;*
- *Part 2: Methods of test for cement-stabilized and lime-stabilized materials.*

The tests for materials in the unstabilized state are given in Part 1 by reference to other British Standards. Except where they are seldom used, or the test procedures are identical in all respects, the tests for materials in the stabilized condition included in Part 2 are given in full, although they may be similar to tests in other British Standards. This is to provide a complete and comprehensive document for use by testing laboratories, and because the tests themselves have to be modified to take account of the presence of the stabilizing agent. This particularly applies to sample preparation.

The title of the standard has been amended to reflect the wider scope of this revision, which is intended to cover, in addition to soils, materials which when stabilized with cement or lime may be used for civil engineering purposes. Although concerned principally with Portland cement, hydrated lime (calcium hydroxide) and quicklime (calcium oxide) it is also applicable to other cements and types of lime, including those in which pulverized fuel ash (pfa) or slag are the major components.

This revision includes all the tests, with minor exceptions, for materials stabilized with lime or cement that were included in the 1975 edition but does not include any tests for materials stabilized with bitumen. In deciding to exclude tests for bitumen-stabilized materials from the revision the Committee consulted extensively on the currency and use of the tests in the 1975 edition and on the existence of or need for other tests. Reader's comments are invited on the need for and contents of a further part (Part 3) of this standard for such tests.<sup>1)</sup>

Lime, and to a lesser extent cement, may also be used to modify rather than to stabilize a material. Modified materials are usually natural soils and probably fine-grained but may be by-products of industrial processes, e.g. colliery spoil. The object of the modification process is to improve the properties of the soil such as shear strength, durability, etc. but the modified material retains many of the properties of soil. The process may, for example, be used to render an unsuitable material suitable for modifying the plasticity characteristics. In these cases the tests in this standard may be suitable but equally the soil tests in BS 1377 referred to in the text may be considered to be applicable to measure the change in properties caused by modifying the soil or other material.

The following tests are included in this standard for the first time:

- a) determination of moisture content by microwave oven, nuclear gauge and by the calcium carbide method;
- b) determination of the moisture condition value;
- c) determination of frost heave;
- d) determination of tensile strength;
- e) determination of the plate loading value;
- f) determination of the degree of carbonation;
- g) determination of the initial consumption of lime.

Typical forms are included for all test methods to illustrate how the results may be conveniently calculated and recorded.

<sup>1)</sup> Comments should be sent to the Secretary, Technical Committee RDB/9, BSI, 2 Park Street, London W1A 2BS.

It has been assumed in the drafting of this standard that the execution of its provisions is entrusted to appropriately experienced people, for whose guidance it has been prepared.

A British Standard does not purport to include all the necessary provisions of a contract. Users of British Standards are responsible for their correct application.

**Compliance with a British Standard does not of itself confer immunity from legal obligations.**

### **Summary of pages**

This document comprises a front cover, an inside front cover, pages i to vi, pages 1 to 104, an inside back cover and a back cover.

This standard has been updated (see copyright date) and may have had amendments incorporated. This will be indicated in the amendment table on the inside front cover.





# Section 1. Scope, definitions and classification tests

## 1.1 Scope

This Part of BS 1924 describes methods of test for materials stabilized with cement or lime for civil engineering purposes.

NOTE The titles of the publications referred to in this standard are listed on the inside back cover.

## 1.2 Definitions

For the purposes of this Part of BS 1924 the definitions given in BS 1924-1 apply.

## 1.3 Determination of moisture content

### 1.3.1 Principle

The methods based on heating to remove water assume that all the “free” water in the stabilized material is removed in the heating process and that “chemically bound” water such as water of hydration is not removed by the test procedure. This is generally true for most materials likely to be encountered but problems can occur with materials that contain hydrated salts such as gypsum ( $\text{CaSO}_4 \cdot 2\text{H}_2\text{O}$ ) that lose water at temperatures below 105 °C (see note 1 to 1.3.3.2.3).

The definitive method of measuring moisture content is the oven-drying method given in 1.3.3 and is based on drying at 105 to 110 °C to remove the water.

Two subsidiary test procedures based on heating to remove the water are also included. Two other subsidiary methods neither of which is based on heating the samples to remove the water are also included. The first of these procedures relies on the reaction of water in the aggregate with calcium carbide to evolve acetylene, the amount of which can be assessed by the pressure it generates in a confined space. In the second the moisture content of the material under test is determined by placing a fast neutron source and a neutron detector on or adjacent to the material under test. The intensity of slow or moderated neutrons detected is dependent on the hydrogen content of the material under test and hence indirectly to the moisture content.

The requirements of BS 1924-1 shall, where appropriate, apply to this test method.

### 1.3.2 Sampling

The sample received at the laboratory (the laboratory sample) shall be taken in accordance with 5.3 of BS 1924-1:1990.

### 1.3.3 Oven-drying method (Definitive method)

#### 1.3.3.1 Apparatus

##### 1.3.3.1.1 Apparatus for all materials

1.3.3.1.1.1 An oven capable of maintaining a temperature of 105 °C ± 5 °C.

#### 1.3.3.1.2 Apparatus for fine-grained materials

1.3.3.1.2.1 A glass weighing bottle, fitted with a ground glass stopper or cap, or a suitable airtight corrosion-resistant metal container.

NOTE A convenient size is one about 50 mm diameter and 25 mm high.

1.3.3.1.2.2 A balance, of 250 g minimum capacity, readable to 0.01 g.

1.3.3.1.2.3 A desiccator, containing anhydrous silica gel.

NOTE 1 A convenient size is 200 mm to 250 mm diameter.

NOTE 2 It is preferable to use self-indicating silica gel as the desiccant can be periodically dried at 110 °C to maintain its blue colour.

#### 1.3.3.1.3 Apparatus for medium-grained materials

1.3.3.1.3.1 An airtight corrosion-resistant container, of about 500 g capacity.

1.3.3.1.3.2 A balance, of 1 kg minimum capacity, readable to 0.1 g.

1.3.3.1.3.3 A medium-sized scoop (see Figure 2 of BS 1924-1:1990).

#### 1.3.3.1.4 Apparatus for coarse-grained materials

1.3.3.1.4.1 An airtight corrosion-resistant container, of about 3 kg capacity.

1.3.3.1.4.2 A balance, of 10 kg minimum capacity, readable to 1 g.

1.3.3.1.4.3 A large scoop (see Figure 2 of BS 1924-1:1990).

#### 1.3.3.2 Procedure

1.3.3.2.1 Reduce the laboratory sample by the procedure described in 3.5 of BS 1924-1:1990 to produce a test portion of mass not less than given in Table 1 appropriate to the material.

Table 1 — Minimum mass of test portions

Grouping of material	Minimum mass of test portion	Accuracy of weighing
	g	g
Fine-grained	30	0.01
Medium-grained	300	0.1
Coarse-grained	3 000	1.0

1.3.3.2.2 Clean and dry the weighing bottle or container, weigh it to the accuracy given in Table 1 and record the mass ( $m_1$ ). Take the test portion of minimum mass, crumble and place it loosely in the container or weighing bottle. Replace the lid or stopper and then weigh the container or bottle and contents to the same degree of accuracy as before. Record the mass ( $m_2$ ).

**1.3.3.2.3** Remove the lid or stopper, and place the container or bottle with its lid and contents in the oven and dry at  $105 \pm 5$  °C (see note 1) for a period which will vary with the amount of material being dried in the oven. The sample shall be deemed to be dry when the differences in successive weighings of the cooled sample (see note 2) at intervals of 4 h do not exceed 0.1 % of the original mass of the sample (see note 2). Do not replace the lid or stopper while the sample is in the oven.

NOTE 1 Some materials contain gypsum which on heating at the specified temperature loses its water of crystallization. The moisture content determined by this method will be affected by approximately 0.2 % for each 1 % of gypsum. If it is suspected that gypsum is present the moisture content samples should be dried at no more than 80 °C and possibly for a longer time. The presence of gypsum can be identified by heating a small quantity of the material on a metal plate. Grains of gypsum will turn white within a few minutes, whereas most other minerals remain unaltered. If the standard conditions are not used, the drying conditions used should be stated in the test record.

NOTE 2 16 h to 24 h is usually a sufficient length of time for drying most materials, but large or wet samples will require longer. The drying time will also depend on the amount of material in the oven.

**1.3.3.2.4** After drying, remove the container, or bottle, and contents from the oven and replace the lid and allow to cool.

NOTE It is impracticable to cool large samples of material in a desiccator and, if the lids of the containers fit well, it is unlikely that the samples will absorb any water from the air during cooling. However, if glass weighing bottles were used for fine-grained material, the container and contents should be allowed to cool in a desiccator and the stoppers should not be replaced until the material has cooled to room temperature.

**1.3.3.2.5** After cooling weigh the container, or bottle, and contents to the same degree of accuracy as previously and record the mass ( $m_3$ ).

### 1.3.3.3 Calculations and expression of results

NOTE A typical data and calculation form for the determination of the moisture content by the oven-drying method is given in form A of Appendix A.

Calculate the moisture content ( $w$ ) of the test portion as a percentage of the dry mass of solids from the equation:

$$w = 100(m_2 - m_3)/(m_3 - m_1)$$

where

$m_1$  is the mass of container (in g);

$m_2$  is the mass of container and wet material (in g);

$m_3$  is the mass of container and dry material (in g).

Express the value of moisture content to the nearest 0.1 % of the dry mass of solids.

## 1.3.4 Sand-bath method

NOTE This method covers the determination of the moisture content of a test portion of stabilized material as a percentage of the dry mass of solids. It is intended as a rapid alternative to the definitive method described in 1.3.3 but is less accurate and is more suitable as a site test. The method should not be used if it is suspected that the material contains gypsum, calcareous matter or organic material, e.g. unburnt coal in minestone and pulverized-fuel ash (pfa).

### 1.3.4.1 Apparatus

#### 1.3.4.1.1 Apparatus for all materials

**1.3.4.1.1.1** *Equipment for heating the sand-bath*, e.g. an electric hot-plate or a gas-ring.

#### 1.3.4.1.2 Apparatus for fine-grained materials

**1.3.4.1.2.1** *An airtight, heat- and corrosion-resistant container*, approximately 50 mm in diameter and 25 mm deep.

**1.3.4.1.2.2** *A balance*, of 250 g minimum capacity, readable to 0.1 g.

**1.3.4.1.2.3** *A sand-bath*, containing clean sand to a depth of at least 25 mm and large enough to take the container.

NOTE A larger bath may be used to heat several containers at once.

**1.3.4.1.2.4** *A palette knife* or other implement for stirring the test portion during drying.

NOTE A convenient size is one having a blade 100 mm long and 20 mm wide.

#### 1.3.4.1.3 Apparatus for medium-grained materials

**1.3.4.1.3.1** *A heat-resistant tray*, approximately 200 mm square and 50 mm deep.

**1.3.4.1.3.2** *A balance*, of 1 kg minimum capacity, readable to 0.5 g.

**1.3.4.1.3.3** *A sand-bath*, containing clean sand to a depth of at least 25 mm and large enough to take the tray.

NOTE A larger bath may be used to heat several samples at once.

**1.3.4.1.3.4** *A palette knife*, or other implement for stirring the test portion during drying.

NOTE A convenient size is one having a blade 100 mm long and 20 mm wide.

**1.3.4.1.3.5** *A medium-sized scoop* (see Figure 2 of BS 1924-1:1990).

#### 1.3.4.1.4 Apparatus for coarse-grained materials

**1.3.4.1.4.1** *A heat-resistant tray*, approximately 250 mm square and 50 mm to 70 mm deep.

**1.3.4.1.4.2** *A balance*, of 10 kg minimum capacity, readable to 1 g.

**1.3.4.1.4.3** *A sand-bath*, containing clean sand to a depth of at least 25 mm and large enough to take the tray.

**1.3.4.1.4.4** *A palette knife*, or other implement for stirring the test portion during drying.

NOTE A convenient size is one having a blade 200 mm long and 30 mm wide.

**1.3.4.1.4.5** A large-sized scoop (see Figure 2 of BS 1924-1:1990).

#### **1.3.4.2** Procedures

##### **1.3.4.2.1** Procedure for fine-grained materials

**1.3.4.2.1.1** Clean, dry and weigh the container to the nearest 0.1 g ( $m_1$ ). Take the test portion of minimum mass 30 g prepared as described in **1.3.3.2** crumble and place loosely in the container, and replace the lid. Weigh the container and contents to the nearest 0.1 g ( $m_2$ ).

**1.3.4.2.1.2** Remove the lid and place the container and contents on the sand-bath, which shall be heated by one of the methods given in **1.3.4.1.1**, care being taken not to get the sand-bath too hot (see note). During heating disturb the sample frequently and thoroughly with the palette knife to assist the evaporation of the water.

NOTE A convenient method of detecting overheating is by the use of small white pieces of paper mixed with the material. Overheating is indicated if the paper turns brown.

**1.3.4.2.1.3** When the container and contents have been heated long enough to dry the sample [1 h is usually sufficient (see note)], remove them from the sand-bath, replace the lid, and allow the whole to cool.

NOTE The drying period will vary with the type of material, the size of samples and the field conditions. It is suggested that when a large number of moisture content determinations are to be made with one material, several measurements should be made using different periods of drying to determine the minimum period required to effect adequate drying. The material shall be deemed to be dry if the additional loss of mass when it is heated for a further period of 15 min does not exceed 0.1 g for fine-grained, 0.5 g for medium-grained and 5 g for coarse-grained materials.

**1.3.4.2.1.4** Weigh the container and contents to the nearest 0.1 g ( $m_3$ ).

##### **1.3.4.2.2** Procedure for medium and coarse-grained materials

**1.3.4.2.2.1** Clean, dry and weigh the tray to the nearest 0.5 g ( $m_1$ ). Take a test portion of minimum mass 300 g for medium-grained materials and 3 kg for coarse-grained materials, prepared as described in **1.3.3.2**, crumble and spread out evenly in the tray. Weigh the tray and contents to the nearest 0.5 g ( $m_2$ ) for medium-grained materials, and to the nearest 5 g ( $m_2$ ) for coarse-grained materials.

**1.3.4.2.2.2** Place the tray on the sand-bath, which shall be heated by one of the methods given in **1.3.4.1.1**, care being taken not to get the sand-bath too hot (see note to **1.3.4.2.1.2**). During heating disturb the sample frequently and thoroughly with the palette knife to assist the evaporation of the water.

**1.3.4.2.2.3** When the tray and contents have been heated long enough to dry the sample [1 h is usually sufficient (see note to **1.3.4.2.1.3**)], remove them from the sand-bath, replace the lid, and allow the whole to cool.

**1.3.4.2.2.4** Immediately the tray is cool enough to handle, weigh the tray and contents to the nearest 0.5 g for medium-grained materials, and to the nearest 5 g for coarse materials ( $m_3$ ).

##### **1.3.4.3** Calculations and expression of results.

Calculate the moisture content ( $w$ ) of the test portion as a percentage of the dry mass of solids from the equation:

$$w = 100(m_2 - m_3)/(m_3 - m_1)$$

where

$m_1$  is the mass of container (in g);

$m_2$  is the mass of container and wet material (in g);

$m_3$  is the mass of container and dry material (in g).

Express the value of moisture content to the nearest 0.1 % of the dry mass of solids.

#### **1.3.5** Microwave oven method (Subsidiary method for fine-grained materials)

NOTE This method covers the determination of the moisture content of a test portion of a stabilized fine-grained material. In favourable circumstances it is a rapid alternative to the definitive method described in **1.3.3** but the range of materials for which it is suitable is restricted and it is confined to fine-grained materials because suitable containers of adequate size are not readily available to hold the required mass of medium and coarse-grained materials.

Most siliceous and calcareous aggregates can be dried satisfactorily in a microwave oven but flints, slag and some calcareous aggregates have a tendency to shatter. Materials such as pulverized fuel ash, colliery spoil (minestone) or aggregates derived from them are not suitable as any carbonaceous matter remaining in them will ignite in the microwave oven. Materials with a high proportion of iron compounds may also give rise to problems. For these reasons it is necessary to carry out preliminary trials to establish whether or not the material under test is adversely affected by microwave radiation.

**1.3.5.1** *Apparatus.* The apparatus shall be as specified for fine-grained materials in **1.3.3.1** except that the oven and airtight corrosion-resistant containers shall be replaced respectively by a well ventilated microwave oven and nonmetal containers of sufficient capacity to hold the mass of the test portion.

NOTE Metal containers cannot be used as they reflect microwaves. Materials such as porcelain and borosilicate glass which heat up under the influence of microwaves and not just by conduction from the aggregate are preferable; this reduces the possibility of water vapour condensing on the cooler walls of the container before being carried away by air circulation. Silica and polypropylene containers may also be used.

**1.3.5.2 Procedure**

**1.3.5.2.1** Carry out preliminary trials to ascertain the time required to dry the test portion and to establish whether or not the material under test is adversely affected by microwave radiation.

**1.3.5.2.2** Follow the procedure described for fine-grained materials described in **1.3.3.2** except that microwave drying is used. Operate the microwave oven in accordance with the manufacturer's instructions.

**1.3.5.3 Calculations and expression of results.** Calculate the moisture content as described in **1.3.3.3** and express the value to the nearest 0.1 % of the dry mass of solids.

**1.3.6 Calcium carbide method (Subsidiary method)**

**1.3.6.1 Principle.** Calcium carbide will react with water in a material to produce acetylene according to the equation

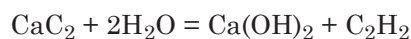

If the reaction is allowed to occur under standardized conditions in a closed container the pressure of the acetylene generated in the container is a measure of the moisture content of the aggregate. The procedure given in this subclause describes how this can be used as a rapid method of determining moisture content of stabilized materials. The test results may not correspond exactly with the definitive oven-drying method.

**1.3.6.2 Apparatus**

**1.3.6.2.1** A calcium carbide pressure moisture meter, calibrated in accordance with the manufacturer's instructions.

**1.3.6.2.2** A balance, of 2 kg minimum capacity, readable to 0.1 g.

**1.3.6.2.3** Steel balls, to aid the mixing process usually supplied with the apparatus.

**1.3.6.2.4** A cleaning brush and a cloth.

**1.3.6.2.5** A scoop, for measuring the calcium carbide reagent.

**1.3.6.3 Reagent**

**1.3.6.3.1** Finely pulverized calcium carbide, of a grade capable of producing acetylene gas in the amount of at least 0.15 m<sup>3</sup>/kg of carbide.

**1.3.6.4 Procedure**

NOTE Only a general procedure is given as the test should always be carried out in accordance with the procedure recommended by the manufacturer.

**1.3.6.4.1** Place the calcium carbide and the steel balls in the larger chamber of the moisture tester.

**1.3.6.4.2** Take a test portion of the stabilized material of known mass (not less than 100 g) and place it in the cap of the tester. With the vessel in an approximately horizontal position, insert the cap in the pressure vessel and seal the unit by tightening the clamp, taking care that no carbide comes into contact with the material until a complete seal is achieved. Then raise the moisture tester to a vertical position so that the aggregate falls into the pressure vessel.

**1.3.6.4.3** Shake the instrument vigorously in a rotary motion so that the calcium carbide can react with the available free water.

NOTE The shaking should continue for at least a minute and time should be permitted to allow dissipation of the heat generated by the chemical reaction.

**1.3.6.4.4** When the needle of the pressure dial stops moving read the dial while holding the instrument in a horizontal position at eye level. Record the dial reading.

**1.3.6.4.5** With the cap of the instrument pointed away from the operator slowly release the gas pressure. Empty the pressure vessel and examine the material for lumps. If the sample is not completely pulverized repeat the test using a new test portion.

**1.3.6.5 Calculations and expression of results.** The dial reading is the percentage of moisture by wet mass. Convert this to the percentage of moisture by dry mass from the equation

$$Y = X \left( 1 - \frac{X}{100} \right)$$

where

Y is the moisture content as a percentage of the dry mass;

X is the moisture content as a percentage of the wet mass;

and record the results to the nearest 0.1 % of the dry mass of solids.

**1.3.7 Nuclear gauge method (for on site testing only)**

For details of the measurement of the in-situ moisture content by nuclear gauges, see **3.7**.

**1.3.8 Test report**

The test report shall affirm that the moisture content was determined in accordance with **1.3** of BS 1924-2:1990 and whether or not a certificate of sampling is available. If available a copy of the certificate of sampling shall be provided. The test report shall contain the following additional information:

a) sample identification;

- b) the moisture content as a percentage of the dry mass of the stabilized material;
- c) the method used for the determination of moisture content, i.e. the definitive oven-drying method or whichever of the subsidiary methods was used.

NOTE Normally the subsidiary methods will be used for site control purposes where the need for a test report will not arise.

## 1.4 Determination of effect of the stabilizer on plasticity properties

### 1.4.1 Principle

Lime (and to a lesser extent cement) has a marked effect on the plasticity properties of materials containing clay minerals. This is brought about by two separate mechanisms; firstly, there is an immediate effect as a result of cation exchange at the surface of the clay particles and, secondly, there is a longer term effect as a result of the pozzolanic reaction between the lime (or lime liberated by hydrated cement) and the clay minerals. The cation exchange reactions have the most influence on the plasticity properties whilst the pozzolanic reaction is largely responsible for the increase in strength which occurs over a period of time.

The requirements of BS 1924-1 shall, where appropriate, apply to this test method.

### 1.4.2 Apparatus

#### 1.4.2.1 General apparatus

**1.4.2.1.1 Apparatus for the determination of moisture content** by the oven-drying method given in 1.3.3.1.

**1.4.2.1.2 A 2 mm and a 425  $\mu\text{m}$  test sieve** with receivers complying with 4.2.4.2 of BS 1924-1:1990.

**1.4.2.1.3 A sharp knife.**

**1.4.2.1.4 An implement for shredding cohesive material.**

**1.4.2.1.5 Two palette knives.**

NOTE A convenient size is one having a blade 200 mm long and 30 mm wide.

**1.4.2.1.6 Airtight containers**, such as polyethylene bags of suitable size and sheets of plastics sheeting.

**1.4.2.1.7 An evaporating dish**, 150 mm in diameter.

**1.4.2.1.8 A flat glass plate.**

NOTE 1 A convenient size is about 10 mm thick and 500 mm square.

NOTE 2 When determining the plastic limit, the condition of the surface of the glass plate may affect the behaviour of the rolled threads. Mixing of material containing silica particles inevitably scratches a glass surface so the plate used for mixing the material with water will not generally be suitable. Use of a separate unscratched glass plate for the rolling operation will reduce discrepancies due to this effect.

**1.4.2.1.9 A wash bottle**, containing distilled or demineralized water.

**1.4.2.1.10 Glass beakers**, of 1 L capacity and a plastic bucket of 5 L capacity.

**1.4.2.1.11 A glass stirring rod.**

**1.4.2.1.12 A length of rubber or plastic tubing**, for connection to the water supply, fitted at the other end with a spray nozzle.

**1.4.2.2 Additional apparatus for determination of the plastic limit**

**1.4.2.2.1 A length of rod**, 3 mm in diameter and about 100 mm long.

**1.4.2.3 Additional apparatus for determination of the liquid limit**

**1.4.2.3.1 A penetrometer**, as used in bituminous material testing complying with BS 2000-49.

**1.4.2.3.2 A cone of machined stainless steel** complying with the essential details shown in Figure 1(a). The surface of the cone shall be smooth, polished and dry (see note). To ensure that the point remains sufficiently sharp for the purpose of the test, the cone shall be replaced if after continued use the point can no longer be felt when brushed lightly with the tip of the finger when the tip of the cone is pushed through a hole  $1.5 \pm 0.02$  mm in diameter, bored through a metal plate  $1.75 \pm 0.1$  mm thick [Figure 1(b)].

NOTE The effect of surface roughness is more significant than small variations in cone angle or bluntness of the tip.

**1.4.2.3.3 One or more metal cups**, approximately 55 mm in diameter and 40 mm deep with the rim parallel to the flat base.

**1.4.2.3.4 A metal straightedge**, with bevelled edge, approximately 150 mm long.

### 1.4.3 Sample preparation

NOTE The procedure given assumes that laboratory trials are being made to find the effect of the addition of stabilizer on the plasticity properties of the material. If it is desired to find the plasticity properties of field-mixed material the sample preparation procedure is not applicable. However, if required the plasticity properties of field-mixed material may be determined with appropriate modifications by the procedure given in 1.4.5 and 1.4.6.

**1.4.3.1 Taking of sample.** The sample received at the laboratory shall be taken in accordance with clause 5 of BS 1924-1:1990.

**1.4.3.2 Reduction of sample.** Reduce the laboratory sample by the procedures described in 1.4.3.3 or 1.4.3.4. Wherever possible the tests shall be carried out on material in its natural state. With many fine-grained material, it is possible to remove the few coarse particles present, i.e. particles retained on a 425  $\mu\text{m}$  sieve, by hand, otherwise these particles shall be removed as described in 1.4.3.4. Do not oven-dry the material and do not allow it to dry in air more than is necessary to prepare the test portions for test.

**1.4.3.3 Initial preparation of cohesive fine-grained materials**

**1.4.3.3.1** From a laboratory sample of fine-grained material in its natural state, and which contains little or no material retained on a 425 µm test sieve, take a representative test portion weighing about 500 g. Cut it into small pieces using a knife or grater and remove any coarse particles by hand or with tweezers.

**1.4.3.3.2** If coarse particles are present determine their mass and the mass of the sample used.

NOTE These weighings enable the approximate proportion of coarse material to be calculated if required.

**1.4.3.3.3** Determine the moisture content of a 50 g sample of the test portion by the oven-drying method described in 1.3.3. Place the remainder of the test portion in an airtight container that is just large enough to hold the material and store until required.

**1.4.3.4 Initial preparation of all other materials**

**1.4.3.4.1** From the laboratory sample take a representative test portion of the material to give a test specimen passing the 425 µm test sieve weighing at least 500 g.

**1.4.3.4.2** From the test portion take a representative sample of mass about 10 % of the total mass for the determination of moisture content ( $w$  %) by the oven-drying method described in 1.3.3.

**1.4.3.4.3** Weigh the remainder of the test portion to an accuracy of within 0.03 %. Record the mass ( $m_1$ ).

**1.4.3.4.4** Place the weighed test portion in a suitable container under just enough distilled or demineralized water to submerge it. Stir the mixture until it forms a slurry.

NOTE If practicable use distilled or demineralized water throughout the stages of washing; on no account should dispersants or flocculating agents be used in this or any subsequent stage.

**1.4.3.4.5** Pour the slurry through a suitable guard sieve (or sieves) and the 425 µm test sieve, nested in a receiver. Use the minimum amount of water necessary to wash the fines through into the receiver (or into a larger container if necessary) until the water passing the 425 µm test sieve is virtually clear.

**1.4.3.4.6** Collect together the washed material retained on the sieves, dry it at 105 °C to 110 °C and determine its mass to the same accuracy as before ( $m_2$ ).

**1.4.3.4.7** Allow the fine particles in the wash water to settle out and after a suitable interval carefully pour off the clear water above the suspension.

**1.4.3.4.8** Allow the suspension to dry partially in a current of warm air, protected from dust, until it forms a stiff paste.

**1.4.3.4.9** Determine the moisture content of a 50 g sample of the test portion by the oven-drying method described in 1.3.3. Place the remainder of the test portion in an airtight container that is just large enough to hold the material and store until required.

**1.4.3.4.10** Calculate the dry mass ( $m_d$ , in g) of the initial test portion and the percentage of particles ( $p_a$ ) passing the 425 µm sieve from the equation

$$m_d = 100m_1/(100 + w)$$

where

$w$  is the moisture content (in %);

$m_1$  is the mass of the sample as determined in 1.4.3.4.3 (in g);

$p_a = 100(m_d - m_2)/m_d$  (in %);

$m_2$  is the mass of the sample as determined in 1.4.3.4.6 (in g).

**1.4.3.5 Preparation of samples for plastic limit determination**

**1.4.3.5.1** Two test samples are required for this determination, one of the material in its natural condition and the other of the material to which the stabilizer has been added.

**1.4.3.5.2** Take two test samples each of mass about 25 g from the paste prepared as described in 1.4.3.3.3 or 1.4.3.4.9. Weigh each sample to 0.1 g and calculate its dry mass from the mass of the wet sample and the value of its moisture content.

**1.4.3.5.3** To one sample add the required amount of stabilizer and mix thoroughly on the glass plate with palette knives. If the immediate effect of the stabilizer on the plastic limit is required determine the plastic limit of both samples as described in 1.4.4. If the change of plastic limit with time is being investigated roll each sample into a ball, wrap each in plastics sheeting and store in an airtight container until required.

**1.4.3.6 Preparation of samples for liquid limit determination**

**1.4.3.6.1** Two test samples are required for this determination, one of the material in its natural condition and the other of the material to which the stabilizer has been added.

**1.4.3.6.2** Take the material, prepared as described in 1.4.3.3.3 or 1.4.3.4.9, set aside about 50 g for the determination of the plastic limit, if this has not already been done. Split the remaining sample in half, weigh each test sample to 0.1 g and calculate its dry mass from the mass of the wet sample and the value of its moisture content.

**1.4.3.6.3** To one sample add the required amount of stabilizer and mix thoroughly with the palette knives on the glass plate. Mix the paste for at least 10 min (see note) and if necessary add more distilled or demineralized water so that the first cone penetration, when tested as described in **1.4.5**, is about 15 mm. If the immediate effect of the stabilizer on the liquid limit is required determine the liquid limit of both samples as described in **1.4.5**. If the change of liquid limit with time is being investigated roll each sample into a ball, wrap each in plastics sheeting and store in an airtight container until required.

NOTE Some materials, e.g. clays of high plasticity, may require up to 40 min of continuous mixing immediately before testing to obtain reliable results.

#### **1.4.4 Determination of the plastic limit**

##### **1.4.4.1 Procedure**

**1.4.4.1.1** For each test sample, allow the sample to dry on the glass plate (**1.4.3.5.3**) until it becomes plastic enough to be shaped into a ball. If the sample is too dry to start with mix it with water until it is in a plastic condition.

**1.4.4.1.2** Mould the ball between the fingers and roll it between the palms of the hands until the heat of the hands has dried the sample sufficiently for cracks to appear on its surface. Divide this sample into two subsamples of approximately 10g each and carry out a separate determination on each portion. Divide each subsample into four approximately equal parts and treat each part as described in **1.4.4.1.3** to **1.4.4.1.7**.

**1.4.4.1.3** Mould the sample in the fingers to equalize the distribution of moisture, then form it into a thread about 6 mm diameter between the first finger and thumb of each hand.

**1.4.4.1.4** Roll the thread between the fingers (finger-tip to the second joint) of one hand and the surface of the glass roiling plate. Use enough pressure to reduce the diameter of the thread to about 3 mm in five to ten complete (forward and back) movements of the hand. (Some heavy clays will require 10 to 15 movements when the sample is near the plastic limit, because the material hardens at this stage). Maintain a uniform rolling pressure and do not reduce the pressure as the thread diameter approaches 3 mm.

**1.4.4.1.5** Pick up the sample, mould it between the fingers to dry it further, form it into a thread and roll it out again as in **1.4.4.1.4**.

NOTE Gradual drying of the material is achieved by alternately rolling and moulding, not by continual rolling (either as a ball or threads) which produces a dry crust.

**1.4.4.1.6** Repeat **1.4.4.1.5** until the thread shears both longitudinally and transversely when it has been rolled to about 3 mm diameter, as gauged by the metal rod (see note). Do not gather the pieces of material together after they have been crumbled, and re-form a thread. The first crumbling point is the plastic limit.

NOTE With materials that are only marginally plastic it is often difficult to obtain the correct crumbling condition.

**1.4.4.1.7** Gather together the portions of the crumbled thread, transfer them to a suitable container and replace the lid immediately.

**1.4.4.1.8** Repeat **1.4.4.1.3** to **1.4.4.1.7** on the other three portions of the sample, replacing them all in the same container, determine the moisture content of the material in the container as described in **1.3.3**.

**1.4.4.1.9** Repeat **1.4.4.1.2** to **1.4.4.1.8** on the duplicate subsample formed in **1.4.4.1.2**.

##### **1.4.4.2 Calculations and expression of results**

NOTE A typical data and calculation form for the determination of the plastic limit is given in form B of Appendix A.

**1.4.4.2.1** Calculate the moisture content of both subsamples tested, as described in **1.3.3**.

**1.4.4.2.2** If the two results differ by more than 0.5 % moisture content repeat the whole test.

**1.4.4.2.3** Calculate the average of the two moisture content values and report this as the plastic limit of the sample under test to the nearest whole number.

#### **1.4.5 Determination of the liquid limit**

##### **1.4.5.1 Procedure**

**1.4.5.1.1** For each test sample, place the test sample on the glass plate and, if necessary, mix with more distilled or demineralized water so that the first cone penetration reading is about 150 mm.

**1.4.5.1.2** Push a portion of the mixed material into the cup with a palette knife taking care not to trap air. Strike off excess material with the bevelled edge of the straightedge to give a smooth surface.

**1.4.5.1.3** With the penetration cone locked in the raised position lower the supporting assembly so that the tip of the cone just touches the surface of the material. When the cone is in the correct position a slight movement of the cup will just mark the surface. Record the reading of the dial gauge to the nearest 0.1 mm.

**1.4.5.1.4** Release the cone for a period of  $5 \pm 1$  s. If the apparatus is not fitted with an automatic release and locking device take care not to jerk the apparatus during this operation. After locking the cone in position lower the dial gauge to the new position of the cone shaft and note the reading to the nearest 0.1 mm. Record the difference between the beginning and end of the drop as the cone penetration.

**1.4.5.1.5** Lift out the cone and carefully clean it, taking care not to scratch the surface.

**1.4.5.1.6** Add a little more wet material to the cup, taking care not to trap air, make the surface smooth as in **1.4.5.1.2** and repeat steps **1.4.5.1.3** to **1.4.5.1.5**.

**1.4.5.1.7** Proceed as follows, as applicable:

- a) if the difference between the first and second penetration readings is less than 0.5 mm record the average of the two penetrations and proceed to **1.4.5.1.8**; or
- b) if the second penetration is more than 0.5 mm and less than 1 mm difference from the first, carry out a third test; if the overall range is not more than 1 mm continue at **1.4.5.1.8**; or
- c) if the overall range is more than 1 mm remove the material from the cup, re-mix and repeat **1.4.5.1.2** to **1.4.5.1.7** until constant results are obtained before proceeding to **1.4.5.1.8**.

**1.4.5.1.8** Take a moisture content sample of about 10 g from the area penetrated by the cone and determine the moisture content as described in **1.3.3**.

**1.4.5.1.9** Repeat steps **1.4.5.1.2** and **1.4.5.1.8** at least three more times using the same sample of material to which further increments of distilled water have been added. The test shall always proceed from the drier to the wetter condition of the material. The amount of water added shall be such that a range of penetration values of approximately 15 mm to 25 mm is covered by the four or more test runs and are evenly distributed. Each time material is removed from the cup for the addition of water the cup shall be washed and dried.

**1.4.5.1.10** If at any time during the above procedure the material has to be left for a short time on the glass plate it shall be covered with the evaporating dish or damp cloth to prevent it drying out.

#### **1.4.5.2** *Calculations and expression of results*

NOTE A typical data and calculation form for the determination of the liquid limit is given in form C of Appendix A.

**1.4.5.2.1** Calculate the moisture content of each separate determination as described in **1.3.3**.

**1.4.5.2.2** Plot the relationship between moisture content and cone penetration with the percentage moisture contents as abscissae and the cone penetrations as ordinates, both on linear scales.

**1.4.5.2.3** Draw the best straight line fitting the plotted points.

**1.4.5.2.4** From the linear graph read off the moisture content corresponding to a cone penetration of 20 mm as the liquid limit of the sample under test.

#### **1.4.6** Derivation of the plasticity index

**1.4.6.1** Determine the plastic limit ( $w_P$ ) by the procedure given in **1.4.4** and the liquid limit ( $w_L$ ) by the procedure given in **1.4.5**.

**1.4.6.2** Calculate the plasticity index ( $i_P$ , in %) from the equation

$$i_P = w_L - w_P$$

#### **1.4.7** Test report

The test report shall affirm that the effect of the stabilizer on the plasticity properties of the material were determined in accordance with **1.4** of BS 1924-2:1990 and whether or not a certificate of sampling is available. If available a copy of the certificate of sampling shall be provided. The test report shall contain the following additional information:

- a) sample identification;
- b) the amount and type of stabilizer used;
- c) the lapse in time (if more than 3 h) between the addition of the stabilizer and carrying out the test;
- d) the plastic limit and/or the liquid limit of the material with and without the addition of stabilizer;
- e) the proportion of material that was used, i.e. the amount that passes the 425  $\mu\text{m}$  test sieve, and the method to be used to obtain the material to be tested, i.e. whether as described in **1.4.3.3** or **1.4.3.4**;
- f) if both the liquid limit and the plastic limit have been determined, the plasticity index.



## 1.5 Determination of degree of pulverization

### 1.5.1 Principle

The determination of the degree of pulverization is carried out on spot samples taken from small areas of the mixed material. It is essential that the individual lumps of material are not broken down during the sampling and sample reduction operations. For this reason it is better to take a sample of the mass required for the test rather than to obtain a larger sample and then to reduce this to the required mass by sample reduction.

The requirements of BS 1924-1 shall where appropriate apply to this test method.

### 1.5.2 Apparatus

**1.5.2.1** A *balance*, of 5 kg minimum capacity, readable to 1 g.

**1.5.2.2** A 5 mm *test sieve*, and receiver, complying with 4.2.4.2 of BS 1924-1:1990.

**1.5.2.3** A *scoop*, e.g. as in Figure 2 of BS 1924-1:1990.

**1.5.2.4** A *tray*, approximately 300 mm square.

### 1.5.3 Procedure

Take a sample of the material approximately 1 kg in mass and weigh to the nearest 1 g ( $m_1$ ). Spread this on the sieve, taking care not to overload it, and shake it gently. Do not force material through the sieve and ensure that the lumps of material are broken as little as possible. Determine the mass of the material retained on the sieve to the nearest 1 g ( $m_2$ ). Break any lumps of the material retained on the sieve until all individual particles finer than 5 mm are separated. Replace on the sieve and shake the sieve until all the material finer than 5 mm has passed through it. Determine the mass of the material that is still retained on the sieve to the nearest 1 g ( $m_3$ ).

### 1.5.4 Calculations and expression of results

NOTE A typical data and calculation form for the determination of the degree of pulverization is given in form D of Appendix A.

**1.5.4.1** Calculate the degree of pulverization ( $P$ , in %) from the equation:

$$P = 100 (m_1 - m_2) / (m_1 - m_3)$$

where

$m_1$  is the total mass of the sample (in g);

$m_2$  is the mass of the unbroken material retained on the sieve (in g);

$m_3$  is the mass of the material finally retained on the sieve (in g).

**1.5.4.2** Report the degree of pulverization to the nearest 5 %.

### 1.5.5 Test report

Normally this test is used for site control purposes where the need for a test report will not arise. If a test report is required it shall affirm that the degree of pulverization was determined in accordance with 1.5 of BS 1924-2:1990. The test report shall contain the following additional information:

- a) sample identification;
- b) the degree of pulverization of the sample to the nearest 5 %.

## Section 2. Compaction related tests

### 2.1 Determination of the dry density/moisture content relation

#### 2.1.1 Principle

Compaction of stabilized material is the process by which the solid particles are packed more closely together, usually by mechanical means, thereby increasing the dry density of the stabilized material. The dry density which can be achieved depends on the degree of compaction applied and the amount of water present in the material. For a given degree of compaction of a given material there is usually an optimum moisture content at which the dry density obtained reaches a maximum value. With free-draining granular materials, however, the moisture/density relation may have little meaning. The requirements of BS 1924-1 shall where appropriate apply to this test method.

#### 2.1.2 Types of test

**2.1.2.1** Three types of compaction test are described each with procedural variations related to the nature of the material. The first of these is the "light" compaction test in which a 2.5 kg rammer is used (see 2.1.3). The second is the "heavy" compaction test which is similar but gives a much greater degree of compaction by using a 4.5 kg rammer with a larger drop on thinner layers of material (see 2.1.4).

**2.1.2.2** For both these tests a 1 L capacity compaction mould is used for fine-grained materials and for medium-grained materials containing less than 5 % retained on a 20 mm test sieve. For other medium-grained materials and for coarse-grained materials the tests are carried out in the larger "CBR" mould (see notes 1 and 2).

**2.1.2.3** The third type of test makes use of vibratory compaction and is intended mainly for granular (non-cohesive) materials. Two methods of vibratory compaction are given, the first (preferred) method uses the special apparatus described in 2.1.5. The second (subsidiary) method uses a hand-held vibrating hammer and a CBR mould (see 2.1.6).

**NOTE 1** The requirements for compaction in the CBR mould are based on the same compactive effort per unit volume of material as in the standard mould. The variable effects of side-wall friction might result in differences between the densities achieved in the two moulds. For a series of tests on a particular material, one size of mould should therefore be used throughout.

**NOTE 2** If more than 15 % of material is retained on a 37.5 mm test sieve the material is too coarse to be tested.

#### 2.1.3 Method using 2.5 kg rammer

**2.1.3.1 Sampling.** The sample received at the laboratory (the laboratory sample) shall be taken in accordance with clause 5 of BS 1924-1:1990.

Reduce the laboratory sample by the procedures described in 5.4 of BS 1924-1:1990 to produce at least five test portions each with an approximate mass of 2.5 kg in the case of fine and medium-grained materials to be compacted in the 1 L mould, or an approximate mass of 8 kg in the case of medium and coarse-grained materials to be compacted in a CBR mould.

#### 2.1.3.2 Apparatus

**2.1.3.2.1 A cylindrical metal mould** (the 1 L compaction mould), having a nominal internal volume of 1 L (for fine-grained and medium-grained materials (see 2.1.2.2)). The mould shall be fitted with a detachable baseplate and a removable extension. Its dimensions shall be as shown in Figure 2 which also indicates one suitable design of mould. The internal faces shall be smooth, clean and dry before each use.

**2.1.3.2.2 A CBR mould** (for medium and coarse-grained materials [see 2.1.2.2]) as used for the determination of the California Bearing Ratio and as specified in 4.5.

**2.1.3.2.3 A metal rammer**, having a 50 mm diameter circular face weighing 2.5 kg and complying with the essential dimensions shown in Figure 3. The rammer shall be equipped with a suitable arrangement for controlling the height of drop to  $300 \pm 3$  mm. The machine shall be firmly supported on a heavy solid base such as concrete floor or plinth.

**NOTE** One suitable form of hand apparatus is shown in Figure 3. A motorized form of the apparatus may be used provided:

- that the essential dimensions of the rammer and mould are adhered to;
- that the rammer has a free vertical fall of the correct controlled height; and
- that the density achieved is within  $\pm 2$  % of the density achieved by using the hand rammer.

**2.1.3.2.4 A balance** of, either:

- 10 kg minimum capacity readable to 1 g, for tests carried out in a standard mould; or
- 25 kg minimum capacity readable to 5 g, for tests carried out in a CBR mould.

**2.1.3.2.5 A palette knife.**

**NOTE** A convenient size is one having a blade approximately 100 mm long and 20 mm wide.

**2.1.3.2.6 A straightedge**, e.g. a steel strip approximately 300 mm long, 25 mm wide and 3 mm thick, with one bevelled edge.

**2.1.3.2.7 A 20 mm and a 37.5 mm test sieve** and receivers.

**2.1.3.2.8 A large metal tray.**

**NOTE** A convenient size is one about 600 mm  $\times$  500 mm with sides 80 mm deep.

**2.1.3.2.9** *Apparatus for determination of the moisture content*, by the oven-drying method given in **1.3.3**.

**2.1.3.2.10** *Apparatus for extracting specimens from the mould* (optional).

**2.1.3.3** *Preparation of the test portions*

**2.1.3.3.1** *For fine and medium-grained materials compacted in the 1 L mould*

**2.1.3.3.1.1** Remove all stones retained on the 20 mm test sieve (see note) from each of the test portions, obtained as described in **2.1.3.1**.

NOTE The removal of small amounts of stone (up to 5 % retained on a 20 mm test sieve) will affect the density obtainable only by amounts comparable with the experimental error involved in measuring the maximum dry density. If more than 5 % of material is retained on the 20 mm test sieve the procedure for medium and coarse-grained materials should be followed.

**2.1.3.3.1.2** Mix each of the test portions with the required amounts of water (see note 1) and stabilizer (see note 2) as described in clause 6 of BS 1924-1:1990. Mix the respective test portions with the different amounts of water to give a suitable range of moisture contents. The range of moisture contents shall be such that the optimum moisture content, at which the maximum dry density occurs, is within that range (see note 3). Do not mix any test portion with stabilizer until it is ready to be compacted.

NOTE 1 The choice of the range of moisture contents to use is inevitably one of trial-and-error and an unfortunate choice could lead to a large number of test portions being required. Consequently although five test portions may be sufficient it is usually necessary to be prepared to produce a larger number than this.

NOTE 2 If the amount of stabilizer required has not been determined at this stage, the amount may be estimated, but the test should be repeated with the required amount of stabilizer if this is found subsequently to be different from the estimated amount.

NOTE 3 The range of moisture contents obtained should include the optimum moisture content and the amounts of water to be added to the test portions will therefore vary with the type of stabilized material under test. In general with non-cohesive materials a minimum moisture content of 4 to 6 % would be suitable with additional increments of 1 to 2 % for each successive test portion tested. With cohesive materials a minimum moisture content of 8 to 10 % below the plastic limit of the material would usually be suitable with additional increments of 2 to 4 % for each successive sample tested. To increase the accuracy of the test it is often advisable to reduce the increments in the region of the optimum moisture content.

**2.1.3.3.2** *For medium and coarse-grained materials compacted in a CBR mould*

**2.1.3.3.2.1** Remove all stones retained on the 37.5 mm test sieve from each of the test portions, obtained as described in **2.1.3.1**. If more than 15 % of material is removed the material is too coarse to be tested by the procedure given here.

**2.1.3.3.2.2** Follow the procedure given in **2.1.3.3.1.2**.

**2.1.3.4** *Compaction procedure for use with the 1 L mould*

**2.1.3.4.1** Weigh the mould with the baseplate attached to the nearest 1 g ( $m_1$ ). Measure the internal dimensions to 0.1 mm to ensure that the mould complies with the specification.

**2.1.3.4.2** Attach the extension to the mould and place the mould assembly on a solid base, e.g. a concrete floor or plinth.

**2.1.3.4.3** Place a quantity of the first test portion in the mould such that when compacted it occupies a little over one-third of the height of the mould body.

**2.1.3.4.4** Apply 27 blows from the rammer dropped from a height of  $300 \pm 3$  mm above the material. Distribute the blows uniformly over the surface and ensure that the rammer always falls freely and is not obstructed by the material in the guide tube. Allow the rammer to fall under its own mass and do not impart any momentum to it when it is released.

**2.1.3.4.5** Repeat Steps **2.1.3.4.3** and **2.1.3.4.4** twice more, so that the amount of material used is sufficient to fill the mould body with the surface not more than 6 mm proud of the upper edge of the mould body (see note). Complete the compaction of the test portion within 20 min of adding water to the mix.

NOTE It is necessary to control the total volume of material compacted since, if the amount of material struck off after removing the extension is too great, the result will be inaccurate.

**2.1.3.4.6** Remove the extension, strike off the excess material and level off the surface of the compacted material carefully to the top of the mould using the straightedge. Replace any coarse particles removed in the levelling process by finer material from the sample, well pressed in.

**2.1.3.4.7** Weigh the material and mould with baseplate to the nearest 1 g ( $m_2$ ).

**2.1.3.4.8** Remove the compacted specimen from the mould and place it on the large metal tray. Take a representative sample of the material for determination of its moisture content by the oven-drying method described in **1.3.3**. Alternatively the whole specimen may be dried out.

**2.1.3.4.9** Repeat steps **2.1.3.4.1** to **2.1.3.4.8** with the remaining test portions to give a total of at least five determinations.

**2.1.3.5** *Compaction procedure for use with the CBR mould*. Follow the procedure given in **2.1.3.4** except for the following.

- a) In **2.1.3.4.1**, weigh the mould, with baseplate attached to the nearest 5 g ( $m_1$ ).
- b) In **2.1.3.4.4**, apply 62 blows from the rammer dropped from a height of  $300 \pm 3$  mm to each layer.
- c) In **2.1.3.4.7**, weigh the material and mould with baseplate to the nearest 5 g ( $m_2$ ).

**2.1.3.6 Calculations and expression of results**

NOTE A typical data and calculation form for the determination of the dry density/moisture content relation is given in form E of Appendix A.

**2.1.3.6.1 Calculations**

**2.1.3.6.1.1** Calculate the bulk density ( $\rho$ , in  $\text{Mg/m}^3$ ) of each compacted specimen from the equation:

$$\rho = (m_2 - m_1)/v$$

where

$m_1$  is the mass of the mould and base (in g);

$m_2$  is the mass of the mould, base and compacted material (in g);

$v$  is the volume of the mould (in mL).

where

$v = 1\,000$ , for a mould having the dimensions shown in Figure 2;

$v = 2\,305$ , for a CBR mould having the dimensions specified in 4.5.2.5.

**2.1.3.6.1.2** Calculate the dry density ( $\rho_d$ , in  $\text{Mg/m}^3$ ) of each compacted specimen from the equation:

$$\rho_d = 100\rho/(100 + w)$$

where

$w$  is the moisture content of the relevant test portion.

**2.1.3.6.1.3** Plot the dry densities, obtained from a series of determinations, as ordinates against the corresponding moisture contents as abscissae. Draw a smooth curve through the points and identify the position of the maximum on this curve (see note). Read off the values of dry density and moisture content to three significant figures corresponding to that point (see Figure 1 of BS 1924-1:1990).

NOTE The maximum may lie between two observed points and care should be taken in drawing the curve not to exaggerate its peak.

**2.1.3.6.1.4** To assist in drawing the curve, and for comparison on the same graph, plot the curves corresponding to zero, 5 % and 10 % air voids calculated from the equation:

$$\rho_d = \rho_w \left[ \frac{1 - \frac{V_a}{100}}{\frac{1}{\rho_z} + \frac{w}{100}} \right]$$

where

$\rho_d$  is the dry density of the stabilized material (in  $\text{Mg/m}^3$ );

$\rho_w$  is the density of water assumed to be 1.000 (in  $\text{Mg/m}^3$ );

$V_a$  is the volume of air voids in the compacted stabilized mixture expressed as a percentage of the total volume of the mixture;

$w$  is the moisture content of the stabilized material (in %);

$\rho_z$  is the combined particle density (in  $\text{Mg/m}^3$ ) of the material plus stabilizer calculated from the equation:

$$\rho_z = \frac{1 + \frac{c}{100}}{\frac{1}{\rho_m} + \frac{c}{\rho_c}}$$

where

$c$  is the stabilizer content expressed as a percentage of the dry material;

$\rho_m$  is the particle density of the material (in  $\text{Mg/m}^3$ );

$\rho_c$  is the particle density of the stabilizer;

where the following values may be assumed:

$\rho_c = 3.12 \text{ Mg/m}^3$  at 20 °C for cement;

$\rho_c = 2.13 \text{ Mg/m}^3$  at 20 °C for lime.

**2.1.3.6.2 Reporting of results.** Report the following information:

- the method used for obtaining the result, i.e. the 2.5 kg rammer method using the 1 L or the CBR mould;
- the amount of material retained on the 20 mm and 37.5 mm test sieves to the nearest 1 %;
- the experimental points and the smooth curve drawn through them (see note) showing the relation between moisture content and dry density;
- the dry density (in  $\text{Mg/m}^3$ ) corresponding to the maximum dry density on the compaction curve to the nearest 0.01;
- the optimum moisture content at which the maximum dry density occurs. Report the values of moisture content to two significant figures.

NOTE For some highly permeable materials such as clean gravels, uniformly graded and coarse-clean sands the results of this test may provide only a poor guide to specifications on field compaction. The laboratory test might indicate meaningless values of moisture content in these free-draining materials and the maximum dry density is often lower than the state of compaction which can be readily obtained in the field.

## 2.1.4 Method using 4.5 kg rammer

**2.1.4.1 Principle.** This method covers the determination of dry density measured as the mass of dry solids per  $\text{m}^3$  when a stabilized material is compacted in a specified manner over a range of moisture contents. The range includes the optimum moisture content at which the maximum dry density for this degree of compaction is obtained. In this test the compactive effort is greater than that used for the 2.5 kg rammer method, the mass of the rammer being increased to 4.5 kg and the height of fall to  $450 \pm 4$  mm. Otherwise the test procedure is broadly similar to that used in the previous test.

**2.1.4.2 Sampling.** The sample received at the laboratory (the laboratory sample) shall be taken in accordance with clause 5 of BS 1924-1:1990.

Reduce the laboratory sample by the procedures described in 5.4 of BS 1924-1:1990 to produce at least five test portions each with an approximate mass of 2.5 kg, in the case of fine and medium-grained materials to be compacted in a 1 L mould, or an approximate mass of 8 kg in the case of medium and coarse-grained materials to be compacted in a CBR mould.

### 2.1.4.3 Apparatus

NOTE The apparatus required for this test is identical to that given in 2.1.3.2 except that the rammer specified in 2.1.3.2.3 is replaced with a rammer as specified in 2.1.4.3.1.

**2.1.4.3.1 A metal rammer**, having a 50 mm diameter circular face, and weighing 4.5 kg. The rammer shall be equipped with a suitable arrangement for controlling the height of drop to  $450 \pm 4$  mm. The machine shall be firmly supported on a heavy solid base such as concrete floor or plinth.

NOTE One suitable form of hand apparatus and the tolerances on the essential dimensions is shown in Figure 4. A motorized form of the apparatus may be used provided:

- that the essential dimensions of the rammer and mould are adhered to;
- that the rammer has a free vertical fall of the correct controlled height;
- that the density achieved is within  $\pm 2\%$  of the density achieved by using the hand rammer.

**2.1.4.4 Preparation of the test portions.** Prepare the test portions of fine and medium-grained materials compacted in the 1 L mould in accordance with 2.1.3.3.1. Prepare the test portions of medium and coarse-grained materials compacted in the CBR mould in accordance with 2.1.3.3.2.

### 2.1.4.5 Compaction procedure for use with the 1 L mould

**2.1.4.5.1** Weigh the mould with the baseplate attached to the nearest 1 g ( $m_1$ ). Measure the internal dimensions to 0.1 mm to ensure that the mould complies with 2.1.3.2.1.

**2.1.4.5.2** Attach the extension to the mould and place the mould assembly on a solid base, e.g. a concrete floor or plinth.

**2.1.4.5.3** Place a quantity of the first test portion in the mould such that when compacted it occupies a little over one-fifth of the height of the mould body.

**2.1.4.5.4** Apply 27 blows from the rammer dropped from a height of  $450 \pm 4$  mm above the material. Distribute the blows uniformly over the surface and ensure that the rammer always falls freely and is not obstructed by the material in the guide tube. Allow the rammer to fall under its own mass and do not impart any momentum to it when it is released.

**2.1.4.5.5** Repeat steps 2.1.4.5.3 and 2.1.4.5.4 four more times, so that the amount of material used is sufficient to fill the mould body with the surface not more than 6 mm proud of the upper edge of the mould body (see note). Complete the compaction of the test portion within 20 min of adding water to the mix.

NOTE It is necessary to control the total volume of material compacted since, if the amount of material struck off after removing the extension is too great, the result will be inaccurate.

**2.1.4.5.6** Remove the extension, strike off the excess material and level off the surface of the compacted material carefully to the top of the mould using the straightedge. Replace any coarse particles removed in the levelling process by finer material from the sample, well pressed in.

**2.1.4.5.7** Weigh the material and mould with baseplate to the nearest 1 g ( $m_2$ ).

**2.1.4.5.8** Remove the compacted specimen from the mould and place it on the large metal tray. Take a representative sample of the material for determination of its moisture content by the oven-drying method described in 1.3.3. Alternatively the whole specimen may be dried out.

**2.1.4.5.9** Repeat steps 2.1.4.5.1 to 2.1.4.5.8 with the remaining test portions to give a total of at least five determinations.

**2.1.4.6 Compaction procedure for use with the CBR mould.** Follow the procedure given in 2.1.4.5 except for the following.

a) In 2.1.4.5.1, weigh the mould, with baseplate attached to the nearest 5 g ( $m_1$ ).

b) In 2.1.4.5.4 apply 62 blows from the rammer dropped from a height of  $450 \pm 4$  mm to each layer.

c) In 2.1.4.5.7 weigh the material and mould with baseplate to the nearest 5 g ( $m_2$ ).

**2.1.4.7 Calculations and expression of results.** Calculate and express the results in accordance with 2.1.3.6.

**2.1.4.8 Reporting of results.** Report the results in accordance with 2.1.3.6.2, except that in a) state that the 4.5 kg rammer method was used.

### 2.1.5 Method using vibratory compaction (Definitive method)

**2.1.5.1 Principle.** This method covers the determination of the dry density measured as the mass of dry solids per cubic metre when a stabilized granular material is compacted in a specified manner by vibratory compaction over a range of moisture contents. For most materials the range includes the optimum moisture content at which the maximum dry density for this degree of compaction is obtained but with some free-draining granular materials no such optimum can be identified (see 2.1.5.8.1.5).

**NOTE** This method is recommended in preference to the methods given in 2.1.3 and 2.1.4 for highly permeable stabilized materials such as clean gravels, uniformly graded and coarse clean sands on which the tests described in 2.1.3 and 2.1.4 may provide only a poor guide for specifications on site compaction. Results given by this method provide a satisfactory guide to the optimum moisture content for site compaction and, generally, the maximum density given by the test is only slightly greater than that obtained on full-scale site operations.

**2.1.5.2 Sampling.** The sample received at the laboratory (the laboratory sample) shall be taken in accordance with clause 5 of BS 1924-1:1990.

Reduce the laboratory sample by the procedures described in 5.4 of BS 1924-1:1990 to produce at least 12 test portions each with an approximate mass of 2.5 kg.

**NOTE** The choice of the range of moisture contents to use is inevitably one of trial-and-error and an unfortunate choice could lead to a large number of test portions being required. Consequently although 12 test portions may be sufficient it is usually necessary to be prepared to produce a larger number than this.

### 2.1.5.3 Apparatus

**NOTE** The design of the apparatus required in 2.1.5.3.1, 2.1.5.3.2 and 2.1.5.3.3 below is subject to crown copyright. The Secretary of State for Transport has agreed with BSI to make available, through the Transport and Road Research Laboratory, licences to market and manufacture this apparatus on non-exclusive and non-discriminatory terms in the form of royalty payments of 7 % of the net selling price of the apparatus. Applicants for licences should apply to the Director, Transport and Road Research Laboratory, Old Wokingham Road, Crowthorne, Berkshire, RG11 6AU.

**2.1.5.3.1 A standard compaction mould,** comprising a body, a base, a filter assembly consisting of a geotextile membrane, having a pore-size of 70 to 100  $\mu\text{m}$  and a permeability under a 100 mm head of water of 50  $\text{L}/\text{m}^2/\text{sec}^2$ , placed between two perforated steel plates and an anvil (see note). Working dimensions of the standard mould are shown in Figure 5. The cylinder bore and external diameter of the anvil shall be parallel, the difference in diameter of the mould and the external surface of the anvil shall be more than 0.3 mm and less than 0.9 mm. The cross-sectional area of the bore of the mould, given to the nearest 10  $\text{mm}^2$ , shall be stamped on the side of the body.

**NOTE** The anvil is fitted with a pair of rubber O-rings which will suffer wear. In time this will allow fines to be forced past the O-rings during compaction. Replacement O-rings should therefore be kept and fitted after 50 uses or earlier if necessary. The O-rings should comply with BS 1806 or BS 4518.

**2.1.5.3.2 An electric vibrating hammer,** having a power consumption of not less than 900 W and capable of delivering about 2 000 blows/min to the anvil. It shall be equipped with a suitable shank which makes contact with the anvil (see Figure 5 and Figure 6). The hammer shall be calibrated as described in 2.1.5.5.

**NOTE 1** The power consumption and frequency requirements are given as a guide to the type of hammer required. To ensure good working order, overhauls and calibrations should be carried out not less frequently than every 50 h of operation, or every 6 months, whichever is shorter.

**NOTE 2** As vibrating hammers of the type used in this test can emit noise levels of up to 100 dB (A), suitable noise-reduction precautions should be taken during use.

**2.1.5.3.3 A suitable loading frame** to permit the hammer to be brought into contact with the anvil in the mould (see Figure 6). The surcharge mass and the length of the lever arm shall be such that when the lever arm is in position the total dead-weight force under the anvil is  $640 \pm 10$  N when the mould is not in position but the rest of the apparatus is assembled.

**2.1.5.3.4 A depth gauge,** clearly readable, to measure the distance between the top of the cylinder and the upper surface of the anvil to an accuracy of 0.1 mm or better.

**2.1.5.3.5 A stopwatch or stopclock** or an automatic timer, readable to 1 s to control the vibrating hammer.

**2.1.5.3.6 Filter papers,** 150 mm in diameter<sup>3)</sup>.

**2.1.5.3.7 A square-holed perforated plate** 37.5 mm test sieve complying with 4.2.4.2 of BS 1924-1:1990.

**2.1.5.3.8 A balance** of 10 kg minimum capacity, readable to 1 g.

<sup>2)</sup> Further information may be obtained from Enquiry Section, BSI, Linford Wood, Milton Keynes MK14 6LE, enclosing a stamped addressed envelope for reply.

<sup>3)</sup> Whatman grade 113 has been found to be suitable.

**2.1.5.3.9** A ventilated-oven temperature-controlled to maintain a temperature of  $105 \pm 50$  °C.

**2.1.5.3.10** Corrosion-resistant, water-tight, containers, such as strong polythene bags which can be adequately sealed.

NOTE At least 16 containers having a minimum capacity of 2 L are required.

**2.1.5.3.11** Apparatus for the determination of the moisture content by the oven drying method described in 1.3.3.

#### 2.1.5.4 Material

**2.1.5.4.1** Clean silica sand, from the Woburn Beds of the Lower Greensand in the Leighton Buzzard district<sup>4)</sup>. The grading shall be such that 100 % passes a 600  $\mu\text{m}$  test sieve and 100 % is retained on a 63  $\mu\text{m}$  test sieve. The sand shall be free from flakey particles, silt, clay and organic matter.

NOTE The sand is required for the calibration of the vibrating hammer; 5 kg is required for each calibration. The sand cannot be re-used (see 2.1.5.5).

#### 2.1.5.5 Calibration of the vibrating hammer

**2.1.5.5.1** Take a sample of the calibrating sand which has not been previously used. Oven-dry the sand, sieve through a 600  $\mu\text{m}$  test sieve and discard the coarse fraction.

**2.1.5.5.2** Weigh out two test portions each of mass  $2.5 \pm 0.1$  kg. Mix each test portion with water to raise its moisture content to  $2.5 \pm 0.25$  %.

**2.1.5.5.3** Compact the sand in the mould in accordance with the procedure given in 2.1.5.7.

**2.1.5.5.4** Carry out the test on each test portion and determine the mean density. Calculate the dry density values to the nearest  $0.002 \text{ Mg/m}^3$ .

**2.1.5.5.5** If the range of values in the two tests exceeds  $0.01 \text{ Mg/m}^3$  repeat the whole procedure. Consider the vibrating hammer suitable for use in this test if the mean dry density exceeds  $1.74 \text{ Mg/m}^3$ .

#### 2.1.5.6 Preparation of test portions

**2.1.5.6.1** Dry the test portions obtained as described in 2.1.5.2, at  $105 \pm 5$  °C (see note 1). Sieve the dried test portions on a 37.5 mm test sieve and reject the material retained after recording the percentage of oversize material (see note 2). Each test portion after removal of the oversize material shall have a dry mass in the range 2.4 kg to 2.6 kg.

NOTE 1 The properties of materials containing a large proportion of clay fines may be changed by oven-drying. If oven-drying is likely to affect the results dry the test portions in air and determine their air-dry moisture contents. Allowance must be made for the water already present in air-dried material when adding stabilizer and water to bring the material to a specified moisture and stabilizer content.

NOTE 2 If more than 15 % of material is removed the aggregate is too coarse to be tested.

**2.1.5.6.2** Mix each of the test portions with the required amount of water and stabilizer (see note 1) as described in clause 4 of BS 1924-1:1990 to give suitable range of moisture contents (see note 2).

NOTE 1 If the amount of stabilizer required has not been determined at this stage, the amount may be estimated, but the test should be repeated with the required amount of stabilizer if this is found subsequently to be substantially different from the estimated amount.

NOTE 2 The range of moisture contents obtained should include the optimum moisture content (OMC) and the amounts of water to be added to the test portions will therefore vary with the type of stabilized material under test. Initially, tests should be carried out at moisture contents 2 % apart to find the approximate location of the optimum moisture content if this is known. The precise location of the optimum moisture content should then be determined from tests carried out at moisture contents 0.5 % apart. These should be chosen so that results are obtained at about the optimum and at two moisture contents each side of the optimum at this spacing. Two test portions should be tested at each moisture content.

Example. Initial tests with duplicate test portions at moisture contents of 2 %, 4 %, 6 % and 8 % suggest that the OMC is about 6.5 %. Further tests are then done at moisture contents of 5.5 %, 6.5 %, 7.0 % and 7.5 % to obtain a good definition of the optimum value. The initial test requires eight test portions and the supplementary test requires another eight test portions.

#### 2.1.5.7 Compaction test procedure

**2.1.5.7.1** Before each compaction test check the compaction mould to ensure that it is thoroughly clean and dry. Assemble the mould body, base, filter plates and fibre filter, taking care to ensure that the parts fit together properly. Tighten the clamps to full tightness.

**2.1.5.7.2** Lay three filter papers flat on the bottom of the mould and insert the anvil into the mould so that it touches the upper filter paper. Apply the vibrating hammer to the anvil for about 5 s to ensure that it is properly bedded. Measure carefully and record, to an accuracy of 0.1 mm, the distance (e) between the bottom of the small hole within the half-ball in the anvil and the top of the mould. Remove the anvil and filter papers. Replace two of the filter papers flat on the bottom of the mould.

**2.1.5.7.3** Remix thoroughly the appropriate test portion in its container. Record the mass of the container and test portion, and also that of the empty container. From these results calculate the initial mass of the test portion ( $m_1$ ) to an accuracy of 0.1 %. Place the whole of the test portion in the mould in such a way as to form a single layer with minimum segregation. Roughly level off the top of the test portion, being careful not to remove any material from the mould, and cover it with the remaining filter paper.

<sup>4)</sup> Further information may be obtained from Enquiries Section, BSI, Linford Wood, Milton Keynes MK14 6LE.

**2.1.5.7.4** Locate the filled compaction mould assembly in the loading frame, insert the anvil into the mould so that it rests on the upper filter paper and place the vibrating hammer in position. Apply the surcharge load and operate the vibrating hammer for  $180 \pm 5$  s to compact the test portion.

After compaction has ended remove the vibrating hammer from the frame and from the mould.

**2.1.5.7.5** With the depth gauge measure carefully and record to an accuracy of 0.1 mm the distance ( $f$ ) between the bottom of the small hole in the anvil and the top of the mould. Calculate the height ( $h = e - f$ ) of the compacted portion. Take care not to disturb the anvil after compaction has ceased and before the depth measurement is made.

**2.1.5.7.6** Extract the compacted test portion in its entirety from the mould, remove the filter papers and transfer the test portion to an appropriate container of known mass. Determine its moisture content by oven-drying the whole contents of the container following the oven-drying method described in 1.3.3. The moisture content so obtained is the residual moisture content ( $W_R$ ), i.e. the moisture content after the compaction process has been completed.

**NOTE** The value of the residual moisture content usually differs from the initial moisture content because some water is squeezed out during compaction. If the value of the residual moisture content differs from the initial moisture content by more than 2 % ignore this particular result when estimating the optimum moisture content (see 2.1.5.8.1.4).

**2.1.5.7.7** Repeat 2.1.5.7.1 to 2.1.5.7.6 until all the remaining test portions have been compacted.

### 2.1.5.8 Calculations and expression of results

#### 2.1.5.8.1 Calculations

**NOTE** A typical data and calculation form for the determination of the dry density/moisture content relation by the vibrating hammer method is given in form F of Appendix A. A model form for one determination is shown in form G of Appendix A; this sets out the stages of the calculations.

**2.1.5.8.1.1** Calculate the dry mass ( $m_2$ , in g) of each test portion from the equation:

$$m_2 = \frac{100m_1}{W + 100}$$

where

$m_1$  is the initial mass of the test portion (solid particles and any contained water) placed in the mould (in g);

$W$  is the initial moisture content of the test portion, i.e. a value in the range  $W, W_1, \dots, W_n$  (in %).

**2.1.5.8.1.2** Calculate the vibrated bulk density ( $\rho$ , in  $\text{Mg/m}^3$ ) of each portion from the equation:

$$\rho = \frac{100m_2(100 + W_R)}{ah}$$

where

$m_2$  is the mass of dry material (in g);

$W_R$  is the residual moisture content of each test portion (in %);

$a$  is the cross-sectional area of the mould (in  $\text{mm}^2$ );

$h = e - f$

where

$e$  is the depth gauge reading in the empty mould (in mm);

$f$  is the depth gauge reading in the filled mould (in mm).

**2.1.5.8.1.3** Calculate the vibrated dry density ( $\rho_d$ , in  $\text{Mg/m}^3$ ) of each test portion from the equation:

$$\rho_d = \frac{1000m_2}{ah}$$

**2.1.5.8.1.4** From the results obtained as described above, plot the vibrated dry density values against the corresponding residual moisture content values using the values obtained for the individual test portions with moisture content as the  $x$  axis of the graph and dry density as the  $y$  axis. In addition plot the three lines representing 0 %, 5 % and 10 % air voids.

**NOTE** Appropriate values of dry density for given moisture contents and air voids may be obtained from the formula given in 2.1.3.6.1.4.

**2.1.5.8.1.5** Record the results as follows:



a) where the curve approximates to a convex curve (see (1) of note), read the peak dry density and the corresponding optimum moisture content from the curve and record to the nearest  $0.1 \text{ Mg/m}^3$  and 0.5 % respectively;

b) where the curve approximates to a concave curve (see (2) of note), take the values for maximum dry density and optimum moisture content as the terminal values and record to the nearest  $0.1 \text{ Mg/m}^3$  and 0.5 % respectively;

c) where no curve can be drawn and the best line through the points is approximately horizontal (see (3) of note) report that no value for optimum moisture content exists and give the value for density for any moisture content.



NOTE Compaction curves for coarse-grained materials and free-draining medium-grained materials take three forms depending on the grading and porosity of the stabilized material under test, as follows:

- (1) **convex:**   
 (2) **concave:**   
 (3) **flat:** 

**2.1.5.8.2 Reporting of results.** Report the following information:

- the method used for obtaining the result, i.e. the definitive method of vibrating compaction;
- the amount of material retained on the 37.5 mm test sieve;
- the experimental points and, where possible, the smooth curve drawn through them showing the relationship between moisture content and dry density;
- where it can be identified, the dry density (in  $\text{Mg/m}^3$ ) corresponding to the maximum dry density on the compaction curve to the nearest  $0.01 \text{ Mg/m}^3$ ;
- where it can be identified, the optimum moisture content at which the maximum dry density occurs to the nearest 0.5 %.

## 2.1.6 Method using vibratory compaction (Subsidiary method)

**2.1.6.1 Principle.** This method covers the determination of the dry density measured as the mass of dry solids per  $\text{m}^3$  when a stabilized granular material is compacted in a specified manner by vibratory compaction over a range of moisture contents. For most materials the range includes the optimum moisture content at which the maximum dry density for this degree of compaction is obtained but with some free-draining granular materials no such optimum can be identified (see **2.1.5.8.1.5**).

NOTE The test is an alternative to the definitive method given in **2.1.5**. Within the limits of experimental error of the test methods it gives the same results as the definitive method and has the same applicability. Where the apparatus is available the definitive method is preferred because it is easier to carry out and less dependent on the skill of the operator.

**2.1.6.2 Sampling.** The sample received at the laboratory (the laboratory sample) shall be taken in accordance with clause **5** of BS 1924-1:1990.

Reduce the laboratory sample by the procedures described in **5.4** of BS 1924-1:1990 to produce at least six test portions each with an approximate mass of 8 kg.

NOTE The choice of the range of moisture contents to use is inevitably one of trial-and-error and an unfortunate choice could lead to a large number of test portions being required. Consequently although six test portions may be sufficient it is usually necessary to be prepared to produce a larger number than this.

### 2.1.6.3 Apparatus

**2.1.6.3.1 A cylindrical metal mould,** such as a CBR mould, 152 mm diameter, with baseplate and extension, similar to that described in **4.5**. The internal faces shall be smooth, clean and dry before each use.

**2.1.6.3.2 An electric vibrating hammer,** having a power consumption between 600 W and 750 W and operating at a frequency between 25 Hz and 45 Hz. The hammer shall be calibrated as described in **2.1.6.5**.

NOTE 1 The power consumption and frequency requirements are given as a guide to the type of hammer required. To ensure good working order, overhauls and calibrations should be carried out not less frequently than every 50 hours of operation, or every 6 months, whichever is shorter.

NOTE 2 See note to **2.1.5.3**.

**2.1.6.3.3 Steel tampers,** for attachment to the vibrating hammer. Suitable designs of tampers are shown in Figure 7.

**2.1.6.3.4 A depth gauge,** or steel rule, or other suitable device which enables the sample depth to be measured to an accuracy of 0.5 mm.

**2.1.6.3.5 A balance,** of 25 kg minimum capacity, readable to 5 g.

**2.1.6.3.6 A straightedge,** e.g. a steel strip about 300 mm long, 25 mm wide and 3 mm thick with one bevelled edge.

**2.1.6.3.7 A 600  $\mu\text{m}$ , 20 mm and 37.5 mm test sieve,** and receivers complying with **4.2.4.2** of BS 1924-1:1990.

**2.1.6.3.8 A large metal tray.**

NOTE A convenient size is one about 600 mm  $\times$  500 mm with sides 80 mm deep.

**2.1.6.3.9 Apparatus for the determination of moisture content,** in accordance with the oven-drying method described in **1.3.3**.

**2.1.6.3.10 A stopclock.**

**2.1.6.3.11 Apparatus for extracting compacted specimens from the mould** (optional).

### 2.1.6.4 Material

**2.1.6.4.1 Clean silica sand,** from the Woburn Beds of the Lower Greensand in the Leighton Buzzard district<sup>5)</sup>. The grading shall be such that 100 % passes a 600  $\mu\text{m}$  test sieve and 100 % is retained on a 63  $\mu\text{m}$  test sieve. The sand shall be free from flakey particles, silt, clay and organic matter.

<sup>5)</sup> Further information may be obtained from Enquiries Section, BSI, Linford Wood, Milton Keynes MK14 6LE.

NOTE The sand is required for the calibration of the vibrating hammer; 5 kg is required for each calibration. The sand cannot be re-used (see 2.1.6.5).

### 2.1.6.5 Calibration of the vibrating hammer

#### 2.1.6.5.1 Calibration test

2.1.6.5.1.1 Take a sample of the calibrating sand which has not been previously used. Oven-dry the sand, sieve through a 600  $\mu\text{m}$  test sieve and discard the coarse fraction.

2.1.6.5.1.2 Weigh out three test portions each of mass  $5 \pm 0.1$  kg. Mix each test portion with water to raise its moisture content to  $2.5 \pm 0.25$  %.

2.1.6.5.1.3 Compact the sand in the mould using the vibrating hammer in accordance with the procedure given in 2.1.6.7.

2.1.6.5.1.4 Carry out the test on each test portion and determine the mean density. Calculate the dry density values to the nearest  $0.002 \text{ Mg/m}^3$ .

2.1.6.5.1.5 If the range of values in the three tests exceeds  $0.01 \text{ Mg/m}^3$  repeat the whole procedure. Consider the vibrating hammer suitable for use in this test if the mean dry density exceeds  $1.74 \text{ Mg/m}^3$ .

2.1.6.5.2 *Pressure check.* The application of pressure combined with vibration is essential to ensure the required degree of compaction. Therefore exert a downward force of 300 N to 400 N on the sample surface, this being greater than the force needed to prevent the hammer bouncing on the material.

NOTE The required pressure can be judged by applying the vibrating hammer, without vibration, to a platform scale. The required force is applied when a mass of 30 kg to 40 kg is indicated.

#### 2.1.6.6 Preparation of test portions

2.1.6.6.1 Dry the test portions obtained as described in 2.1.6.2, at  $105 \pm 5$  °C (see note 1). Sieve the dried test portions on a 37.5 mm test sieve and reject the material retained after recording the percentage of oversize material (see note 2). Each test portion after removal of the over size material shall have a dry mass in the range 6 kg to 8 kg.

NOTE 1 The properties of materials containing a large proportion of clay fines may be changed by oven-drying. If oven-drying is likely to affect the results dry the test portions in air and determine their air-dry moisture contents. Make allowance for the water already present in air-dried material when adding stabilizer and water to bring the material to a specified moisture and stabilizer content.

NOTE 2 If more than 15 % of material is removed the aggregate is too coarse to be tested.

2.1.6.6.2 Mix each of the test portions with the required amount of water and stabilizer (see note 1) as described in clause 6 of BS 1924-1:1990 to give a suitable range of moisture contents (see note 2). In the case of cement-stabilized materials do not mix any test portion with cement until it is ready to be compacted.

NOTE 1 If the amount of stabilizer required has not been determined at this stage, the amount may be estimated, but the test should be repeated with the required amount of stabilizer if this is found subsequently to be substantially different from the estimated amount.

NOTE 2 The range of moisture contents obtained should include the optimum moisture content and the amounts of water to be added to the test portions will therefore vary with the type of stabilized material under test. Initially, tests should be carried out at moisture contents 2 % apart to find the approximate location of the optimum moisture content if this is not known. The precise location of the optimum moisture content should then be determined from tests carried out at moisture contents 0.5 % apart. These should be chosen so that results are obtained at about the optimum and at two moisture contents each side of the optimum at this spacing.

#### 2.1.6.7 Compaction test procedure

2.1.6.7.1 Weigh the mould with the baseplate attached to 5 g ( $m_1$ ). Measure the internal dimensions of the mould to 0.1 mm to ensure that it is within specification.

2.1.6.7.2 Attach the extension to the mould and place the mould assembly on a solid base, e.g. a concrete floor or plinth.

2.1.6.7.3 Place a quantity of the first test portion to be tested in the mould such that when compacted it occupies a little over one-third of the height of the mould body.

2.1.6.7.4 Place the circular tamper on the material and compact with the vibrating hammer for  $60 \pm 5$  s. During this period apply a steady downward force on the hammer so that the total downward force on the sample (including that from the mass of the hammer) is between 300 N and 400 N.

2.1.6.7.5 Remove any loose material lying on the surface of the sample or around the sides of the mould.

2.1.6.7.6 Repeat steps 2.1.6.7.3, 2.1.6.7.4 and 2.1.6.7.5 twice more.

2.1.6.7.7 Lay a straightedge across the top of the extension collar and measure down to the surface of the sample to an accuracy of 0.5 mm. Take readings at four points spaced evenly over the surface of the sample, all at least 15 mm from the side of the mould. Calculate the mean height, ( $h$ , in mm) of the sample. If the sample is less than 127 mm or more than 133 mm in height, reject it and repeat the test from 2.1.6.7.3.

2.1.6.7.8 Weigh the material and mould with baseplate to 5 g ( $m_2$ ).

2.1.6.7.9 Remove the compacted material from the mould and place it in the large metal tray. Take a representative sample of the material for determination of its moisture content by the oven-drying method described in 1.3.3. Alternatively the whole specimen may be dried out.

**2.1.6.7.10** Repeat steps **2.1.6.7.3** to **2.1.6.7.9** with each of the remaining test portions.

### 2.1.6.8 Calculations and expression of results

#### 2.1.6.8.1 Calculations

**2.1.6.8.1.1** Calculate the bulk density ( $\rho$ , in Mg/m<sup>3</sup>) of each compacted test portion from the equation:

$$\rho = \frac{1000(m_2 - m_1)}{ah}$$

where

$m_1$  is the mass of mould and base (in g);

$m_2$  is the mass of mould base and compacted material (in g);

$h$  is the height of the compacted sample (in mm);

$a$  is the cross-sectional area of the mould (in mm<sup>2</sup>).

NOTE For a CBR mould having a diameter of 152 mm,  $a = 18145.8 \text{ mm}^2$ .

**2.1.6.8.1.2** Calculate the dry density ( $\rho_d$ , in Mg/m<sup>3</sup>) of each compacted specimen from the equation:

$$\rho_d = \frac{100\rho}{100 + W}$$

where

$w$  is the moisture content of the stabilized material.

**2.1.6.8.1.3** From the results obtained as described above, plot the vibrated dry density values against the corresponding moisture content values with moisture content as the  $x$  axis of the graph and dry density as the  $y$  axis. The three lines representing 0 %, 5 % and 10 % air voids should also be plotted. Appropriate values of dry density for given moisture contents and air voids may be obtained from the formula given in **2.1.3.6.1.4** and the procedure for plotting the curves is described in **2.1.5.8.1.4** and **2.1.5.8.1.5**.

**2.1.6.8.2 Reporting of results.** Report the following information:

- the method used for obtaining the result, i.e. the vibrating hammer method;
- the amount of material retained on the 37.5 mm test sieve;
- the experimental points and, where possible, the smooth curve drawn through them showing the relationship between moisture content and dry density;
- where it can be identified, the dry density (in Mg/m<sup>3</sup>) corresponding to the maximum dry density on the compaction curve to the nearest 0.01 Mg/m<sup>3</sup>;

e) where it can be identified, the optimum moisture content at which the maximum dry density occurs to the nearest 0.5 %.

#### 2.1.7 Test report

The test report shall affirm that the dry density/moisture content relationship was determined in accordance with **2.1** of BS 1924-2:1990 and whether or not a certificate of sampling is available. If available a copy of the certificate of sampling shall be provided. In addition the test report shall contain the following information:

- sample identification;
- the method used for the determination of the dry density/moisture content relationship;
- all the information in **2.1.3.6.2**, **2.1.4.8**, **2.1.5.8.2** or **2.1.6.8.2**, whichever is appropriate.

## 2.2 Determination of the moisture condition value (MCV)

### 2.2.1 Principle

The MCV test involves the determination of the compactive effort necessary in terms of the number of blows of a rammer to compact almost fully a sample of the material under test. It is based on the fact that relations between density and moisture content produced by different compactive efforts tend to converge as the moisture content increases. To determine the MCV, a sample of the material is placed in a mould and the penetration of the rammer into the mould is measured at various stages of compaction. The penetration of the rammer at any given number of blows is compared with the penetration for four times as many blows and the difference in penetration determined. The change in penetration is plotted against the logarithm (to the base 10) of the number of blows corresponding to a change in penetration of 5 mm in the plotted curve.

The requirements of BS 1924-1 shall, where appropriate, apply to this test method.

### 2.2.2 Sampling

**2.2.2.1** The determination of the MCV is carried out on samples of the stabilized material at pre-determined intervals after it has been mixed and is about to be compacted. The samples for the determination of the MCV shall be taken in accordance with clause 5 of BS 1924-1:1990.

**2.2.2.2** Reduce the sample by the procedures described in **5.4** of BS 1924-1:1990 to produce a test portion on which the MCV is to be determined that has a mass of 1.5 kg after any individual particles retained on a 20 mm test sieve have been removed. If particles larger than 20 mm have been removed weigh the material passing the sieve and take a representative portion for the determination of the moisture content.

**NOTE** If a moisture content determination proves to be necessary the initial mass of the test portion shall be such that 1.5 kg of material is available for the determination of the MCV. The aggregations of material need not be broken down any further after passing through the 20 mm sieve.

**2.2.3 Procedure for determination of the MCV**

Determine the MCV in accordance with clause **5** of BS 1377-4:1990.

**2.2.4 Procedure for determination of the MCV/moisture content relation**

Determine the MCV/moisture content relation in accordance with **5.5.1.2** of BS 1377-4:1990.

## Section 3. In-situ density tests

**NOTE** This section describes the methods to be used for determining the in-situ density of a stabilized material. Several methods are included, the choice of which depends on the type of material, the circumstances in which the test is being made and on the equipment available. The applicability of the methods and their limitations are given under each test procedure.

Several of the methods included in this section are also to be found, with minor differences of detail, in BS 1377 and they use apparatus that is identical to that used for the corresponding methods in that standard.

### 3.1 Nuclear moisture/density gauges

For general definitions see clause 2 of BS 1924-1:1990.

Several models of nuclear moisture/density gauges are available commercially for the measurement of both density and moisture content. They measure density either by the back-scatter method as shown in Figure 8(a) or by the direct-transmission method shown in Figure 8(b). The principles on which the gauges work are described in 3.7.

### 3.2 Sampling

The determination of the in-situ density is carried out on small areas of compacted material so that the advice on sampling given in clause 5 of BS 1924-1:1990 is not generally applicable. It is impracticable to obtain a single sample that is representative of a given area of compacted material; selected locations of material therefore have to be tested to find the variability of the in-situ density within the area of compacted stabilized material.

### 3.3 Sand replacement method

#### 3.3.1 Principle

A hole is dug in the compacted stabilized material to the full depth of the compacted layer and the mass and moisture content of the stabilized material removed from the hole are determined. The volume of the hole is then determined by finding the mass of sand of known bulk density that is required to fill it. From the mass of material removed from the hole and the volume of the hole, the bulk density of the stabilized material is calculated and, if required, the dry density is calculated from the results of the bulk density and moisture content determinations.

The requirements of BS 1924-1 shall where appropriate apply to this test method.

#### 3.3.2 Apparatus

##### 3.3.2.1 Apparatus for all materials

**3.3.2.1.1** *Suitable tools for excavating holes in compacted stabilized material, e.g. bent spoon, chisel, hammer, dibber, large screwdriver and/or pointed steel rod about 250 mm long and 7 mm to 10 mm in diameter with a wooden handle.*

**3.3.2.1.2** *A balance, of 10 kg minimum capacity, readable to 1 g (see note to 3.3.4.1.1).*

**3.3.2.1.3** *Metal trays or containers, to take excavated material and to take the supply of sand to fill the pouring cylinder.*

**3.3.2.1.4** *Apparatus for moisture content determination by the oven-drying method described in 1.3.3.*

**3.3.2.1.5** *A glass plate approximately 10 mm thick and approximately 500 mm square if the small pouring cylinder is used, and approximately 600 mm square if the large pouring cylinder is used.*

#### 3.3.2.2 Additional apparatus for fine and medium-grained materials

**NOTE** This apparatus is for the determination of the in-situ density of compacted stabilized fine and medium-grained materials for which a 115 mm diameter sand pouring cylinder is used. The method is applicable to layers not exceeding 150 mm in thickness. For layers between 150 mm and 250 mm the apparatus described in 3.3.2.3 should be used.

**3.3.2.2.1** *A small pouring cylinder similar in essential details to that shown in Figure 9.*

**3.3.2.2.2** *A cylindrical metal calibrating container with an internal diameter of  $100 \pm 2$  mm and an internal depth of  $150 \pm 3$  mm (see note) of the type shown in Figure 10, fitted with a lip 50 mm wide and approximately 5 mm thick surrounding the open end.*

**NOTE** If for any reason it is necessary to excavate the holes to depths less than 150 mm, either the calibrating container should be replaced by one of the same depth as the hole excavated, or its effective depth should be reduced to that of the hole excavated.

**3.3.2.2.3** *A metal tray approximately 300 mm square and 40 mm deep with a hole of approximately 100 mm diameter in the centre.*

#### 3.3.2.3 Additional apparatus for coarse-grained materials

**NOTE** This apparatus is for the determination of the in-situ density of compacted stabilized materials containing stones which makes the test procedure with the apparatus described in 3.3.2.2 difficult to perform. It is an alternative to the apparatus described in 3.3.2.2 for fine and medium-grained stabilized materials and should be used instead for layers exceeding 250 mm in thickness.

**3.3.2.3.1** *A large pouring cylinder, similar in essential details to that shown in Figure 11.*

**3.3.2.3.2** *A cylindrical metal calibrating container, with an internal diameter of  $200 \pm 5$  mm and an internal depth of  $250 \pm 5$  mm (see note) of the type shown in Figure 12, fitted with a lip 75 mm wide and about 5 mm thick surrounding the open end.*

**NOTE** If for any reason it is necessary to excavate the holes to depths less than 250 mm, either the calibrating container should be replaced by one of the same depth as the hole excavated, or its effective depth should be reduced to that of the hole excavated.

**3.3.2.3.3** A metal tray, approximately 500 mm square and 50 mm deep with a hole of approximately 200 mm diameter in the centre.

### 3.3.3 Material

#### 3.3.3.1 Clean closely graded sand.

NOTE 1 Material passing the 600  $\mu\text{m}$  sieve and retained on the 200  $\mu\text{m}$  test sieve, free from flakey particles, silt, clay and organic matter, which has been oven-dried and stored for a suitable period in an open container to allow its moisture content to reach equilibrium with atmospheric humidity, is suitable.

NOTE 2 Generally a storage period, after oven-drying, of about 7 days is sufficient for the moisture content of the sand to reach equilibrium with the atmospheric humidity. The sand should not be stored in an airtight container and should be mixed thoroughly before use. If sand is salvaged from the holes in compacted materials after carrying out this test, it is advisable to sieve, dry and store this sand again before it is used in further sand replacement tests.

### 3.3.4 Calibration

#### 3.3.4.1 Determination of the mass of sand in the cone of the pouring cylinder

**3.3.4.1.1** Fill the pouring cylinder so that the level of the sand in the cylinder is within about 15 mm of the top. Find its total initial mass ( $m_1$ ) to the nearest 0.1 % (see note) and maintain this constant throughout the tests for which the calibration is used. Allow a volume of sand, equivalent to that of the excavated hole in the soil, or equal to that of the calibrating container, to run out. Close the shutter on the pouring cylinder and place the cylinder on a plane surface, e.g. the glass plate.

NOTE The total mass, when it is filled with sand, of the large pouring cylinder described in **3.3.2.3.1** exceeds the capacity of the balance so that the method of filling and weighing is to weigh the sand in two or three containers and tip it into the pouring cylinder before using. Take care to see that the same initial mass as is used in calibrating the apparatus is used for each density measurement. Enough sand should be used to ensure that 4 kg to 5 kg of sand is left in the pouring cylinder after the test is completed.

**3.3.4.1.2** Open the shutter of the pouring cylinder and allow sand to run out. Do not tap or otherwise vibrate the cylinder during this period. When no further movement of sand takes place in the cylinder, close the shutter and carefully remove the cylinder.

**3.3.4.1.3** Collect the sand, on the glass plate, that had filled the cone of the pouring cylinder and determine its mass ( $m_2$ ) to the nearest 0.1 %.

**3.3.4.1.2** Repeat these measurements at least three times and calculate the mean value of  $m_2$ .

#### 3.3.4.2 Determination of the bulk density ( $\rho_s$ ) of the sand

**3.3.4.2.1** Determine the internal volume ( $v$ , in mL) of the calibrating container from the mass of water required to fill it (see note to **3.3.4.1.1**) as described in **3.3.4.2.2** below.

**3.3.4.2.2** Place the empty container on the flat pan of the balance, ensuring that the upper rim of the container is horizontal, if necessary by embedding the base in plasticine or similar material. Note the mass of the container, together with any plasticine, to the nearest 1 g ( $m_5$ ). Then fill the calibrating container almost to the brim with water, taking care not to spill any water on the pan of the balance or on the outside of the container. Lay a straightedge across the top of the container and add water slowly and carefully by means of a dropping rod until the water just touches the straightedge. Remove the straightedge and note the mass of the container plus water to the nearest 1 g ( $m_6$ ). Repeat the measurement a number of times to obtain an accurate mean value for  $m_6$ . For the repeat tests it is only necessary to remove a small amount of water by means of the dropping rod, and to refill the container to the level of the straightedge. The volume of the calibrating container ( $v$ , in mL) is given by the equation:

$$v = m_6 - m_5$$

**3.3.4.2.3** Place the pouring cylinder, after it has been filled to the constant mass ( $m_1$ ), concentrically on the top of the calibrating container as described in **3.3.4.1.1**. Keep the shutter on the pouring cylinder closed during this operation. Open the shutter and allow the sand to run out. Do not tap the pouring cylinder or otherwise vibrate it during this period. When no further movement of the sand takes place in the cylinder, close the shutter. Remove the pouring cylinder with the sand remaining in it and determine their combined mass ( $m_3$ ) to the nearest 0.1 % of the initial mass.

NOTE Stand the calibration container on a tray during this part of the test procedure, to collect the sand overflowing when the cone of the cylinder is removed.

**3.3.4.2.4** Repeat these measurements at least three times and calculate the mean value of  $m_3$ .

NOTE Since variations in atmospheric humidity affect the moisture content of the sand, and hence its bulk density, the calibration should be made (or at least checked) during each day's work. To overcome the effects of slight variations in grading and particle shape between batches of sand, each batch should be sampled and calibrated.

### 3.3.5 Test procedure

**3.3.5.1** Select as described in **3.2** a flat area approximately 450 mm square of the compacted material to be tested. Brush away any loose material lying on the surface and remove any surface dressing or curing membrane as far as it is possible without removing the surface layer of compacted material.

NOTE Erroneously high values of density can be obtained as a result of the excavated hole slumping before the volume is measured. In the case of cement-stabilized materials this problem can be overcome by delaying the test until the material has gained sufficient stability to prevent the slump. The delay is usually not more than a few hours.

**3.3.5.2** Lay the metal tray on the prepared surface with the hole over the portion of the material to be tested. Using this hole as a pattern, excavate a round hole, approximately 100 mm in diameter and to the depth of the layer to be tested up to a maximum of 150 mm deep if the small pouring cylinder is used and up to 250 mm deep if the large pouring cylinder is used (see notes to **3.3.2.2**, **3.3.2.3** and note to this subclause). Do not leave loose material in the hole, and do not distort the immediate surround to the hole (see note). Carefully collect all the excavated material from the hole and determine its mass to the nearest 1 g ( $m_w$ ). Remove the metal tray before placing the pouring cylinder in position over the excavated hole.

**NOTE** Do not enlarge the hole by levering the excavating tool against the side, as this will result in lower densities being recorded. The hammer and chisel should be used for loosening individual stones without disturbing the surrounding material. This is especially important in the case of weak materials or those tested at an early age.

**3.3.5.3** Place a representative sample of the excavated material in a suitable airtight container and determine its moisture content ( $w$ ) as described in **1.3** (see note). Alternatively the whole of the excavated material may be dried and weighed to give the mass ( $m_d$ ) of the dry material removed from the hole.

**NOTE** The calcium carbide and nuclear gauge methods described respectively in **1.3.6** and **1.3.7** do not give results of sufficient accuracy to be used for the determination of the dry mass of material removed from the hole and/or the calculation of dry density. They should not therefore be used for this purpose. Any of the other methods described may be used, subject to their limitations which are given for the individual test procedures.

**3.3.5.4** Place the pouring cylinder, filled to the constant mass ( $m_1$ ) as in **3.3.4.1.1** so that the base of the cylinder covers the hole concentrically. Ensure the shutter on the pouring cylinder is closed during this operation. Open the shutter and allow sand to run out; during this period do not vibrate the cylinder or the surrounding area. When no further movement of the sand takes place close the shutter. Remove the cylinder and determine its mass ( $m_4$ ) to the nearest 0.1 %.

### 3.3.6 Calculations and expression of results

**NOTE** A typical data and calculation form for the determination of the in-situ density by the sand replacement method is given in form H of Appendix A.

**3.3.6.1** Calculate the mass ( $m_a$ , in g) required to fill the calibrating container from the equation:

$$m_a = m_1 - m_3 - m_2$$

where

$m_1$  is the mass of the cylinder and sand before pouring into the calibrating container (in g);

$m_2$  is the mass of sand in the cone (in g);

$m_3$  is the mean mass of cylinder and sand after pouring into the calibrating container (in g).

**3.3.6.2** Calculate the bulk density of the sand ( $\rho_s$ , in Mg/m<sup>3</sup>) from the equation:

$$\rho_s = m_a/v$$

where

$v$  is the volume of the calibrating container (in mL).

**3.3.6.3** Calculate the mass of sand ( $m_b$ , in g) required to fill the excavated hole from the equation:

$$m_b = m_1 - m_4 - m_2$$

where

$m_1$  is the mass of the cylinder and sand before pouring into the calibrating container (in g);

$m_2$  is the mass of sand in the cone (in g);

$m_4$  is the mass of the cylinder and sand after pouring into the hole (in g).

**3.3.6.4** Calculate the bulk density ( $\rho$ , in Mg/m<sup>3</sup>) of the stabilized material from the equation:

$$\rho = m_w \rho_s / m_b$$

where

$m_w$  is the total mass of material excavated (in g);

$m_b$  is the mass of sand required to fill the hole (in g);

$\rho_s$  is the bulk density of the sand (in Mg/m<sup>3</sup>).

**3.3.6.5** If required, calculate the dry density ( $\rho_d$ , in Mg/m<sup>3</sup>) of the stabilized material either from the equation:

$$\rho_d = 100\rho/100 + w$$

where:

$w$  is the moisture content of the stabilized material (in %);

or from the equation:

$$\rho_d = \rho_s m_d / m_b$$

where

$m_d$  is the mass of oven-dry material from the hole (in g).

$m_b$  is the mass of sand required to fill the hole (in g).

**3.3.6.6** Express the value of the bulk and/or dry density in Mg/m<sup>3</sup> to the nearest 0.01 Mg/m<sup>3</sup>.

### 3.3.7 Test report

Report the results in accordance with **3.8**.

### 3.4 Core-cutter method (for unhardened fine-grained materials)

NOTE This method covers the determination of the in-situ density of freshly laid compacted fine-grained stabilized materials. It is applicable only where the material is free from stones and sufficiently soft for the cutter to be driven easily into the compacted material. If required the dry density can be calculated from the results of the bulk density and moisture content determinations.

#### 3.4.1 Principle

A core of stabilized material is removed by driving a cylindrical cutter of known volume into the compacted material. The in-situ bulk density is calculated from a knowledge of the mass and volume of the material removed. If required the dry density is calculated from the results of the bulk density and moisture content determinations.

The requirements of BS 1924-1 shall where appropriate apply to this test method.

#### 3.4.2 Apparatus

**3.4.2.1** A *cylindrical core-cutter*, of the type shown in Figure 13(c), 130 ± 2 mm long (see note) and of 100 ± 2 mm internal diameter, with a minimum wall thickness of 3 mm and bevelled at one end. This cutter shall be kept adequately greased.

NOTE If the average density over a smaller depth is required, then the appropriate length of cutter should be used.

**3.4.2.2** *Steel dolly*, of the type shown in Figure 13(b), 25 mm high and of 100 mm internal diameter, with a wall thickness of 6 mm, fitted with a lip to enable it to be located on top of the core-cutter.

**3.4.2.3** *Steel rammer*, of the type illustrated in Figure 13(a).

**3.4.2.4** A *balance*, of 10 kg minimum capacity, readable to 1 g.

**3.4.2.5** *Palette knife*.

NOTE A convenient size is one having a blade approximately 200 mm long and 30 mm wide.

**3.4.2.6** *Steel rule*, approximately 300 mm long, graduated to 0.5 mm.

**3.4.2.7** *Grafting tool*, or spade and pick-axe.

**3.4.2.8** *Straightedge*, e.g. a steel strip approximately 300 mm long, 25 mm wide and 3 mm thick, with one bevelled edge.

**3.4.2.9** *Apparatus for the determination of moisture content*, by the oven-drying method described in 1.3.3.

**3.4.2.10** *Apparatus for extracting samples from the cutter* (optional).

#### 3.4.3 Test procedure

**3.4.3.1** Calculate the internal volume ( $V_c$ , in mL) of the core-cutter from its dimensions which shall be measured to the nearest 0.5 mm.

**3.4.3.2** Weigh the cutter and determine its mass ( $m_c$ ) to the nearest 1 g.

**3.4.3.3** Select, as described in 3.2, a flat area of approximately 300 mm square of the compacted material to be tested and, if necessary, trim down to a level surface. Remove loose extraneous material. Place the steel dolly on top of the cutter, and ram the latter into the compacted layer until 5 mm to 10 mm of the dolly protrudes above the surface, care being taken not to rock the cutter. Dig the cutter out of the surrounding stabilized material and trim both ends of the core flat to the ends of the cutter with a knife or a spatula and check for flatness with the straightedge.

**3.4.3.4** Determine, to the nearest 1 g, the mass ( $m_a$ ) of the cutter containing the core.

**3.4.3.5** Remove the core from the cutter, crumble it and place a representative sample in an airtight container and determine its moisture content as described in 1.3.

NOTE The calcium carbide and nuclear gauge methods described respectively in 1.3.6 and 1.3.7 do not give results of sufficient accuracy to be used for the determination of the dry mass of material removed from the hole and/or the calculation of dry density. They should not therefore be used for this purpose. Any of the other methods described may be used, subject to their limitations which are given for the individual test procedures.

#### 3.4.4 Calculations and expression of results

NOTE A typical data and calculation form for the determination of the in-situ density by the core-cutter method is given in form I of Appendix A.

**3.4.4.1** Calculate the bulk density ( $\rho$ , in Mg/m<sup>3</sup>) from the equation:

$$\rho = (m_a - m_c)/V_c$$

where

$m_a$  is the mass of stabilized material together with the core-cutter (in g);

$m_c$  is the mass of the core-cutter (in g);

$V_c$  is the volume of the core-cutter (in mL).

**3.4.4.2** If required calculate the dry density ( $\rho_d$ , in Mg/m<sup>3</sup>) from the equation:

$$\rho_d = 100\rho/(100 + w)$$

where

$w$  is the moisture content of the stabilized material (in %).

**3.4.4.3** Express the value of the bulk and/or dry density in Mg/m<sup>3</sup> to the nearest 0.01 Mg/m<sup>3</sup>.

#### 3.4.5 Test report

Report the results in accordance with 3.8.



### 3.5 Immersion in water method

NOTE This method covers the determination of the density of a sample of compacted stabilized material. The method can be employed whenever lumps of suitable size can be obtained; in particular it is a convenient method of determining the density of cores cut from hardened stabilized material. An acceptable alternative to this method is given in 3.6. Although the sample should preferably be cylindrical or cubical, the test can be carried out quite satisfactorily on specimens of other shapes providing no one dimension is very much smaller than the other two.

#### 3.5.1 Principle

The method makes use of Archimedes' principle, i.e. the apparent loss in mass of the sample when it is immersed in water is equal to the mass, and hence the volume, of the water displaced. The mass of the sample is therefore determined first in air; its apparent mass when it is suspended in water is then determined. The density is calculated from the values thus determined for the mass and volume of the sample.

The requirements of BS 1924-1 shall where appropriate apply to this test method.

#### 3.5.2 Apparatus

**3.5.2.1** A balance, of 10 kg minimum capacity, readable to 1 g.

**3.5.2.2** A suitable metal or plastics watertight container, such as a large bucket in which the samples can be immersed.

**3.5.2.3** A cradle and supporting frame, similar in principle to that shown in Figure 14, with which the frame attached to the weighing system of the balance can support the cradle below the balance.

NOTE The arrangement of the cradle and supporting frame shown in Figure 14 has been found to be convenient but any other method which enables the specimen to be suspended in water supported by the weighing system of the balance above would also be satisfactory.

**3.5.2.4** Equipment for melting paraffin wax.

**3.5.2.5** Apparatus for the determination of the moisture content by the oven-drying method as described in 1.3.3 (see note to 3.5.6.4).

#### 3.5.3 Materials

**3.5.3.1** Paraffin wax.

**3.5.3.2** Modelling clay or putty.

#### 3.5.4 Preparation of apparatus

**3.5.4.1** Support the balance with the scoop or platform over the cylindrical container and with at least 300 mm clear space between the underside of the supports and the top of the container. A suitable arrangement is shown in Figure 14.

**3.5.4.2** Fill the watertight container with water to within approximately 80 mm of the top. Place it below the balance and adjust the cradle and supporting frame, so that the cradle is suspended in the water without touching either the bottom or the sides of the container. Ensure that the largest specimen to be tested will be immersed completely when on the cradle.

**3.5.4.3** Place a counter mass on the scale pan to bring the reading on the balance back to zero.

#### 3.5.5 Preparation of the test specimens

**3.5.5.1** Trim the lumps of material to be tested to a suitable size and shape. Take care not to remove all the loosely bonded material if the specimen is honeycombed, and also to keep the specimen representative of the full depth of the layer. As the accuracy of the test depends upon the size of the specimen used, use the largest available specimen compatible with the capacity of the balance. If necessary reduce the size of the lumps to produce suitable specimens of regular shape and having minimum masses of 2 kg for fine- and medium-grained materials and 4 kg for coarse-grained materials. Weigh the specimens to the nearest 1 g ( $m_a$ ).

**3.5.5.2** Determine the densities of the prepared specimens using the procedure given in either 3.5.6 or 3.5.7 depending on the state of compaction of the material and the size and number of the voids.

#### 3.5.6 Test procedure for dense specimens with no large voids

NOTE Only dense, well compacted specimens having a few small air voids should be tested by this procedure. Specimens with either a few large air voids due to poor local compaction, or many small air voids due to poor general compaction or bad grading of the material used, should be tested by the procedure given in 3.5.7.

**3.5.6.1** Place the specimen, prepared as described in 3.5.5, under water in a container so that it is immersed completely and then left to soak for at least 24 h.

**3.5.6.2** When the specimen is removed from the water allow the free water in the specimen to drain away and then weigh and record its mass ( $m_a$ ) to the nearest 1 g.

**3.5.6.3** Immediately after weighing the specimen place it in the cradle and suspend this cradle from the weighing system of the balance (see note). Measure the apparent mass ( $m_b$ ) of the specimen while suspended in water to the nearest 1 g.

**NOTE** When the specimen is placed in the water, supported by the cradle, care should be taken to ensure that no air bubbles are trapped underneath the specimen. Also, while measuring the apparent mass of the specimen when suspended in water, it should be ensured that the specimen is immersed completely. If this is not the case, either the level of water in the container should be raised or the supporting frame should be adjusted until the specimen is immersed completely. The specimen should then be removed from the cradle and the apparatus adjusted as in 3.5.4.

**3.5.6.4** Remove the specimen from the cradle and dry in the oven at a temperature of  $105 \pm 5$  °C (see note). The period required for drying will vary with the type of material and the size of the specimen. The specimen shall be deemed to be dry when successive weighings of the sample, carried out at intervals of 4 h, do not differ by more than 0.1 % of the original mass. After drying place the specimen in a container, replace the lid and allow to cool. When cool, weigh the specimen and record its mass ( $m_d$ ) to the nearest 1 g.

**NOTE** If a suitable size of oven is not available break the sample into fragments and take a representative sample for the determination of the moisture content.

### 3.5.7 Test procedure for specimens with large voids

**3.5.7.1** Dry the specimen, prepared as described in 3.5.5 in an oven at a temperature of  $105 \pm 5$  °C (see note). The period required for drying will vary with the type of material and the size of specimen. The specimen shall be deemed to be dry when successive weighings of the sample, carried out at intervals of 4 h, do not differ by more than 0.1 % of the original mass. After drying place the specimen in a container, replace the lid and allow to cool. When cool weigh the specimen and record its mass ( $m_d$ ) to the nearest 1 g.

**NOTE** When a temperature-controlled drying oven is not available the specimen may be tested without drying in which case it becomes necessary to determine its moisture contents at a subsequent stage (see 3.5.7.5).

**3.5.7.2** Fill all the surface voids in the specimen with a suitable material which is insoluble in water (see note). After filling the voids weigh the specimen to the nearest 1 g and record its mass ( $m_p$ ).

**NOTE** Care should be taken to fill only air voids and not holes resulting from the loss of stone during collection and preparation of the specimen. In filling the voids the material used should be trimmed level with the surface of the specimen.

**3.5.7.3** Coat the specimen completely by repeated dipping in molten paraffin wax (see note). Allow the waxed specimen to cool and then weigh and record its mass ( $m_w$ ) to the nearest 1 g. Calculate the mass ( $m$ , in g) of the paraffin wax adhering to the specimen from the equation:

$$m = m_w - m_f$$

where

$m_w$  is the mass of the specimen after coating with wax (in g);

$m_f$  is the mass of the specimen after filling air voids with modelling clay or putty (in g).

**NOTE** Waxing of the specimens should be carried out very carefully. Surface depressions, including cavities left by stones, should be first coated with molten wax applied by brush, and allowed to set before dipping. Air bubbles should not be allowed to form under the wax. Cavities considered to be part of the existing voids should be made up with filler before waxing. To avoid shrinking and cracking of the wax coating, the wax should be only just molten when applied. In the absence of a temperature controlled waxpot, use of a carpenter's glue pot helps to avoid overheating.

**3.5.7.4** Place the waxed specimen in the cradle and suspend the cradle from the weighing system of the balance (see note). Record the apparent mass ( $m_g$ ) of the specimen, whilst it is suspended in water, to the nearest 1 g.

**NOTE** When the specimen is placed in water, supported by the cradle, care should be taken that no air bubbles become trapped beneath the specimen. Also, whilst measuring the apparent mass of the specimen when suspended in water, it should be ensured that the specimen is completely immersed. If this is not the case, either the level of water in the container should be raised or the supporting frame should be adjusted until the specimen is immersed completely. The specimen should then be removed from the cradle and the apparatus re-adjusted as described in 3.5.4.

**3.5.7.5** Remove the specimen from the cradle. If the specimen was not dried as described in 3.5.7.1 remove the wax coating from the specimen and take a representative sample for the determination of the moisture content ( $w$ ) by one or other of the methods given in 1.3.3 to 1.3.5. Make sure that the portion used for the determination of the moisture content is completely free from paraffin wax, modelling clay or putty.

### 3.5.8 Calculations and expression of results

**NOTE** A typical data and calculation form for the determination of the in-situ density by the immersion in water method is given in form J of Appendix A.

**3.5.8.1** *Dense specimens with no large voids (not coated with wax)*

**3.5.8.1.1** Calculate the volume ( $V_s$ , in mL) occupied by the specimen from the equation:

$$V_s = m_a - m_b$$

where

$m_a$  is the mass of the soaked specimen immediately before weighing in water (in g);

$m_b$  is the apparent mass of the specimen when suspended in water (in g).

**3.5.8.1.2** Calculate the bulk density ( $\rho$ , in Mg/m<sup>3</sup>) from the equation:

$$\rho = m_s/V_a$$

where

$m_s$  is the mass of the specimen (in g), prepared as described in 3.5.5.

**3.5.8.1.3** Calculate the dry density ( $\rho_d$ , in Mg/m<sup>3</sup>) from the appropriate equation as follows:

- a) for specimens dried completely after weighing suspended in water, as in **3.5.6.4**:

$$\rho_d = m_d/V_s$$

where

$m_d$  is the mass of the specimen after drying (in g);

- b) for specimens not dried after weighing suspended in water, as in **3.5.7.5**:

$$\rho_d = 100m_c/V_s(100 + w)$$

where

$m_c$  is the mass of the specimen immediately before it is broken up for moisture content determination (in g);

$w$  is the moisture content of the stabilized material (in %).

**3.5.8.2 Specimens with large voids (coated with wax)**

**3.5.8.2.1** Calculate the volume ( $V_s$ , in mL) occupied by the specimen from the equation:

$$V_s = (m_w - m_g) - (m/\rho_p)$$

where

$m_w$  is the mass of the specimen and wax coating (in g);

$m_g$  is the apparent mass of the specimen and wax coating when suspended in water (in g);

$m$  is the mass of the wax coating (in g);

$\rho_p$  is the density of the paraffin wax (in g/mL).

**3.5.8.2.2** Calculate the bulk density ( $\rho$ , in Mg/m<sup>3</sup>) of the stabilized material from the equation:

$$\rho = m_s/V_s$$

where

$m_s$  is the mass of the specimen, prepared as described in **3.5.5**, (in g).

**3.5.8.2.3** Calculate the dry density ( $\rho_d$ , in Mg/m<sup>3</sup>) of the stabilized material from the appropriate equation as follows:

- a) for specimens dried before filling air voids and coating with wax as in **3.5.7.1**:

$$\rho_d = m_d/V_s$$

where

$m_d$  is the mass of the specimen before drying (in g).

- b) for specimens not dried before filling air voids and coating with wax:

$$\rho_d = 100\rho/(100 + W)$$

where

$w$  is the moisture content of the stabilized material (in %).

**3.5.8.3** Express the value of the bulk and/or dry density in Mg/m<sup>3</sup> to the nearest 0.01 Mg/m<sup>3</sup>.

### 3.5.9 Test report

Report the results in accordance with **3.8**.

## 3.6 Water displacement method

**NOTE** This method describes the determination of the density of a sample of compacted stabilized material. The method can be employed whenever lumps of suitable size can be obtained; in particular it is a convenient method of determining the density of cores cut from hardened stabilized material. An acceptable alternative to this method is given in **3.5** but it requires more specialized equipment. Although the sample should preferably be cylindrical or cubical, the test can be carried out quite satisfactorily on specimens of other shapes providing no one dimension is very much smaller than the other two. In obtaining the lumps of material and trimming them to a suitable size and shape for testing, care should be taken not to remove all the loosely bonded material if the specimen is honeycombed, and also to keep the specimen representative of the full depth of the layer. As the accuracy of the test depends upon the size of the specimen used, it is important that the largest available specimen compatible with the capacity of the apparatus should be used.

### 3.6.1 Principle

The volume of a specimen of known mass is determined by totally immersing the specimen in water and measuring the volume of water displaced. The density is then calculated from the values obtained for the mass and the volume.

The requirements of BS 1924-1 shall where appropriate apply to this test method.

### 3.6.2 Apparatus

**3.6.2.1** A *balance*, of 10 kg minimum capacity, readable to 1 g.

**3.6.2.2** A *cylindrical metal container*, fitted with a siphon tube, of the type shown in Figure 15 for fine- and medium-grained materials and Figure 16 for coarse-grained materials.

**3.6.2.3** A *watertight container*, to act as a receiver for the water siphoning over from the container described in **3.6.2.2**.

**NOTE** A convenient size is one about 250 mm in diameter and 250 mm deep.

**3.6.2.4** *Equipment for melting paraffin wax*.

**3.6.2.5** *Apparatus for determining the moisture content* by the oven-drying method as described in **1.3.3** (see note to **3.6.6.1**).

### 3.6.3 Materials

**3.6.3.1** *Paraffin wax*.

**3.6.3.2** *Modelling clay or putty*.

### 3.6.4 Preparation of the test specimens

**3.6.4.1** If necessary reduce the size of the samples, which should be taken as described in 3.2 to produce suitable specimens of regular shape and having minimum masses of 2 kg for fine- and medium-grained materials and 4 kg for coarse-grained materials. Weigh the specimens to the nearest 1 g ( $m_s$ ).

**3.6.4.2** Determine the densities of the prepared specimens using the procedure given in either 3.6.5 or 3.6.6 depending on the state of compaction of the material and the size and number of the voids.

NOTE Only dense, well-compacted specimens having a few small air voids should be tested by the procedure given in 3.6.5. Specimens with either a few large air voids due to poor local compaction, or many small air voids due to poor general compaction or bad grading of the material used, should be tested by the procedure given in 3.6.6.

### 3.6.5 Test procedure for dense specimens with no large voids

**3.6.5.1** Place the specimen, prepared as described in 3.6.4 under water in a container so that it is immersed completely and then left to soak for at least 24 h.

**3.6.5.2** When the specimen is removed from the water allow the free water in the specimen to drain away and then weigh and record its mass ( $m_a$ ) to the nearest 1 g.

**3.6.5.2** Pour water into the metal container, standing on a level base, until the level of the liquid is well above the siphon tube. Release the clip on the rubber outlet tube and allow excess water to run to waste. Retighten the clip.

**3.6.5.4** Weigh the container for receiving the water and record its mass ( $m_1$ ) to the nearest 1 g. Place it below the siphon outlet and lower the specimen carefully into the container (see note) so that no portion of the specimen projects above the level of the siphon. Then release the clip on the siphon outlet tube allowing the displaced water to siphon over into the receiver. After all the excess water has been siphoned off retighten the clip on the outlet tube. Weigh the receiver and water to the nearest 1 g and record the mass ( $m_2$ ). Calculate the total volume of water ( $V_s$ , in mL) siphoned over into the receiver from the equation:

$$V_s = m_2 - m_1$$

where

$m_2$  is the mass of receiver and water siphoned over into the receiver (in g);

$m_1$  is the mass of the receiver (in g).

NOTE When the specimen is placed in water in the container take care to see that no air-bubbles are trapped underneath the specimen.

**3.6.5.5** Remove the specimen from the container and dry out in the oven at a temperature of  $105 \pm 5$  °C (see note). The period required for drying will vary with the type of material and the size of the specimen. The specimen shall be deemed to be dry when successive weighings of the sample, carried out at intervals of 4 h, do not differ by more than 0.1 % of the original mass. After drying place the specimen in a container, replace the lid and allow to cool. When cool, weigh the specimen and record its mass ( $m_d$ ) to the nearest 1 g.

NOTE If a suitable size of oven is not available break the sample into fragments and take a representative sample for the determination of the moisture content by one of the methods given in 1.3.3 to 1.3.5.

### 3.6.6 Test procedure for specimens with large voids

**3.6.6.1** Dry the specimen, prepared as described in 3.6.4 in an oven at a temperature of  $105 \pm 5$  °C (see note) for a period which will vary with the type of material and the size of specimen. The specimen shall be deemed to be dry when successive weighings of the sample, carried out at intervals of 4 h, do not differ by more than 0.1 % of the original mass. After drying place the specimen in a container, replace the lid and allow to cool. When cool weigh the specimen and record its mass ( $m_d$ ) to the nearest 1 g.

NOTE When a temperature-controlled drying oven is not available the specimens may be tested without drying in which case it becomes necessary to determine their moisture contents at a subsequent stage (see 3.6.6.6).

**3.6.6.2** Fill all the surface voids in the specimen with a suitable material which is insoluble in water. After filling the voids weigh the specimen to the nearest 1 g and record its mass ( $m_p$ ).

NOTE Care should be taken to fill only air voids and not holes resulting from the loss of stone during collection and preparation of the specimen. In filling the voids the material used should be trimmed level with the surface of the specimen.

**3.6.6.3** Coat the specimen completely by repeated dipping in molten paraffin wax (see note). Allow the waxed specimen to cool; then weigh and record its mass ( $m_w$ ) to the nearest 1 g. Calculate the mass ( $m_f$ , in g) of the paraffin wax adhering to the specimen from the equation:

$$m = m_w - m_f$$

where

$m_w$  is the mass of the specimen after coating with wax (in g);

$m_f$  is the mass of the specimen after filling air voids with modelling clay or putty (in g).

**NOTE** Waxing of the specimens should be carried out very carefully. Surface depressions, including cavities left by stones, should be first coated with molten wax applied by brush, and allowed to set before dipping. Air bubbles should not be allowed to form under the wax. Cavities considered to be part of the existing voids should be made up with filler before waxing. To avoid shrinking and cracking of the wax coating, the wax should be only just molten when applied. In the absence of a temperature-controlled waxpot, use of a carpenter's glue pot helps to avoid overheating.

**3.6.6.4** Pour water into the metal container standing on a level base, until the level of the liquid is well above the siphon tube. Release the clip on the rubber outlet tube and allow excess water to run to waste. Retighten the clip.

**3.6.6.5** Weigh the container for receiving the water and record its mass ( $m_1$ ) to the nearest 1 g. Place it below the siphon outlet and lower the specimen carefully into the container (see note) so that no portion of the specimen projects above the level of the siphon. Take care to see that no air-bubbles are trapped underneath the specimen. Then release the clip on the siphon outlet tube allowing the displaced water to siphon over into the receiver. After all the excess water has been siphoned off retighten the clip on the outlet tube. Weigh the receiver and water to the nearest 1 g and record the mass ( $m_2$ ). Calculate the total volume of water  $V_b$ , in mL siphoned over into the receiver from the equation:

$$V_b = m_2 - m_1$$

where

$m_2$  is the mass of receiver and water siphoned over into the receiver (in g);

$m_1$  is the mass of the receiver (in g).

**3.6.6.6** Remove the specimen from the container. If the specimen was not dried as described in **3.6.6.1** remove the wax coating from the specimen and take a representative sample for the determination of the moisture content ( $w$ ) by one or other of the methods given in **1.3.3** to **1.3.5**. Make sure that the portion used for the determination of the moisture content is completely free from paraffin wax, modelling clay or putty.

### 3.6.7 Calculations and expression of results

**NOTE** A typical data and calculation form for the determination of the in-situ density by the water-displacement method is given in form K of Appendix A.

**3.6.7.1 Dense specimens with no large voids (not coated with wax)**

**3.6.7.1.1** Calculate the bulk density ( $\rho$ , in Mg/m<sup>3</sup>) from the equation:

$$\rho = m_a/V_s$$

where

$m_a$  is the mass of the wet specimen, as described in **3.6.5.2** (in g);

$V_s$  is the volume of the specimen, as described in **3.6.5.4** (in mL).

**3.6.7.1.2** Calculate the dry density ( $\rho_d$ , in Mg/m<sup>3</sup>) from the appropriate equation as follows:

a) for specimens dried completely after volume measurement, as in **3.6.5.5**:

$$\rho_d = m_d/V_s$$

where

$m_d$  is the mass of the specimen after drying (in g);

b) for specimens not dried after volume measurement (see note to **3.6.5.5**):

$$\rho_d = \frac{100m_c}{V_s(100 + w)}$$

where

$m_c$  is the mass of the specimen immediately before it is broken up for moisture content determination (in g);

$w$  is the moisture content of the stabilized material (in %).

**3.6.7.2 Specimens with large voids (coated with wax)**

**3.6.7.2.1** Calculate the volume ( $V_s$ , in mL) occupied by the specimen from the equation:

$$V_s = V_b - (m/\rho_p)$$

where

$V_b$  is the volume of the specimen and wax coating (in mL);

$m$  is the mass of the wax coating (in g);

$\rho_p$  is the density of the paraffin wax (in g/mL).

**3.6.7.2.2** Calculate the bulk density ( $\rho$ , in Mg/m<sup>3</sup>) of the stabilized material from the equation:

$$\rho = m_s/V_s$$

where

$m_s$  is the mass of the specimen as in **3.6.4.1** (in g).

**3.6.7.2.3** Calculate the dry density ( $\rho_d$ , in Mg/m<sup>3</sup>) of the stabilized material from the appropriate equation as follows:

a) for specimens dried before filling air voids and coating with wax as in **3.6.6.1**

$$\rho_d = m_d/V_s$$

where

$m_d$  is the mass of the specimen before drying (in g).

b) for specimens not dried before filling air voids and coating with wax (see note to 3.6.6.1):

$$\rho_d = 100\rho/(100 + w)$$

where

$w$  is the moisture content of the stabilized material (in %).

**3.6.7.3 Expression of results.** Express the value of the bulk and/or dry density in  $\text{Mg/m}^3$  to the nearest  $0.01 \text{ Mg/m}^3$ .

### 3.6.8 Test report

Report the results in accordance with 3.8.

## 3.7 Nuclear gauge method

**CAUTION.** The nuclear equipment used in this test method utilizes radioactive materials emitting ionizing radiations which may be hazardous to the health of users, unless proper precautions are taken. Before testing begins it is therefore essential that users of the equipment are aware of the potential hazards and comply with all applicable government regulations concerning the precautions to be taken and routine procedures to be followed with this type of equipment.

Keep time spent near the gauge to a minimum in order to minimize radiation effects.

**NOTE** The following documents regulate the use, etc. of nuclear gauges in the UK:

- Radioactive Substances Act 1960;
- Radioactive Substances (Carriage by Road) (Great Britain) Regulations 1985 and associated Code of Practice;
- Ionising Radiations Regulations 1985 with the associated Approved Code of Practice "The protection of persons against ionising radiation arising from any work activity" (ACoP); Part 2 section 8 of ACoP is relevant;
- Section 6 of the Health and Safety at Work, etc., Act, 1974, HSW 74, (as amended by the Consumer Protection Act, 1987, and modified by Regulation 32 of the Ionising Radiations Regulations, 1985, IRR 85).

Advice regarding a), b) and c) may be obtained from the National Radiological Protection Board, Chilton, Oxon OX11 0RQ. Advice regarding d) may be obtained from the Health and Safety Executive, Magdalen House, Stanley Precinct, Bootle, Merseyside L20 3QZ.

### 3.7.1 General

**3.7.1.1** This method covers the determination in-situ of the density and moisture content of compacted stabilized materials by means of a nuclear gauge designed to operate on the surface of the compacted material.

The standard means of measuring density and moisture content with nuclear gauges have been taken together because the gauges normally combine both facilities. Hence such gauges provide a rapid non-destructive technique for determining in-situ bulk and dry density as well as the moisture content. However, gauges capable only of measuring bulk density may also be used to carry out this test method. The direct measurements made with the nuclear gauge are as follows:

- bulk density, i.e. the combined masses of solids and water per unit volume of the material;

- moisture density, i.e. the mass of water per unit volume of the material.

**NOTE** This value is not the same as the moisture content. The terms "bulk density" and "moisture density" have been used throughout this standard when describing measurements made with nuclear gauges in order to distinguish them from the derived values of dry density and moisture content. Most gauges are microprocessor-controlled and are able to provide derived values of dry density and moisture content.

The nuclear gauge method is suitable for most stabilized materials (see 3.7.1.3) where the plan area of the gauge is of a sufficient size to provide a representative sample. The presence of occasional coarse gravel-sized particles or larger particles completely surrounded by finer material should be revealed by tests giving unusually high density results. Where the material is composed mainly of coarse particles their maximum nominal size should not exceed 37.5 mm.

**3.7.1.2** Bulk density measurements may be made using nuclear gauges in either of two different modes. These modes are referred to as:

- direct transmission;
- backscatter.

The principles on which each are based are shown in Figure 8. Direct transmission is the preferred type and should be used where possible because of its deeper zone of influence (the backscatter mode will permit density measurement only to a depth of 70 mm to 80 mm).

Moisture density can be determined only by using the backscatter type of transmission. However, many gauges permit measurement of moisture density while at the same time measuring bulk density by either mode of transmission.

The zone of influence including the depth below the surface for either type of measurement is not precise and will depend on the design of the gauge and, in the case of the bulk density determination, will also vary with the type of transmission. Typically the measurement depth for bulk density by direct transmission is between 50 mm and 300 mm but only 70 mm to 80 mm for backscatter. In the case of moisture content determination about half of the measured count rate may refer to the uppermost 50 mm; the overall depth sampled will vary with the moisture density.

**3.7.1.3** Test results by both direct transmission and backscatter methods may be affected by a number of factors as follows.

a) Both density and moisture content measurements may be affected by the following:

i) heterogeneity in the chemical composition of the material, e.g. the sporadic presence of metallic iron in slags and coal in colliery spoil;

ii) unusual chemical composition of the materials; some elements such as cadmium, boron and chlorine can have an effect on the measurement of moisture content since they have high thermal-neutron capture probabilities. When such elements are present the method has to be used with caution.

Where the material contains constituent elements that affect determinations with nuclear gauges it may be possible to adjust the calibration curve if the proportions present are reasonably constant.

iii) Surface texture of the material, the effect of which should be minimized by ensuring maximum contact between the gauge and the compacted surface of the material under test. The surface texture effect is much less in the direct transmission mode.

b) Density measurements may be affected by layers of compacted stabilized material which contain significant vertical gradients of density such that the state of compaction at the top bears little relation to the average density conditions throughout the layer. The backscatter test, by its mode of operation, is concentrated on material close to the surface. The direct transmission method is therefore preferred as it reduces these effects due to its deeper zone of influence.

c) Moisture content measurements may be affected by constituent material other than water containing hydrogen and water which is not removed during the oven-drying process. Examples of such materials are those containing organic matter or chemically bound water in sufficient amounts to affect the result.

### 3.7.2 Principles

**3.7.2.1 Bulk density.** The method uses the attenuation of gamma rays from a gamma source (usually in a movable probe) due to Compton scattering and photoelectric absorption. The intensity of radiation arriving at the detector (usually fixed in the base of the gauge) which is directly related to the electron density provides an indication of the bulk density by comparison with an appropriate calibration.

**3.7.2.2 Moisture density.** The method uses the moderation (slowing down) of neutron radiation from a fast neutron source due to collisions, principally with hydrogen nuclei. The intensity of radiation reaching the detector is directly related to the state of arrival of modified neutrons and provides an indication, by comparison with an appropriate calibration, of the amount of moisture present within the volume of the zone of influence. It is assumed that water represents the only source of hydrogen present in the stabilized material.

### 3.7.3 Apparatus

**3.7.3.1 Calibrated nuclear gauge,** suitable for bulk density and moisture density measurements (see note 1). It shall contain sealed nuclear sources adequately shielded for safety during storage and use, and suitable detectors and readout devices with electrical batteries, within a housing of rugged construction that is water and dust resistant. For the determination of bulk density by direct transmission, the housing shall also contain a moveable gauge probe for locating the bulk density measuring source in a preformed hole in the material to be tested. The probe aperture shall be fitted with an automatic shutter and shield mechanism which closes when the probe is withdrawn into the safe position.

NOTE 1 A nuclear gauge limited to bulk density measurements may be used provided it complies with the specification.

NOTE 2 A manufacturer's handbook and certificates of calibrations, and an approved transport case shall also be provided. The gauge shall be recalibrated after any repair or overhaul involving change of the sources, detectors or reference blocks.

NOTE 3 If defects in a source are suspected or if a source is damaged or thought to be damaged the equipment should be left in its storage box and the manufacturer or an authorized agent notified immediately. Handling and repair should be undertaken only by suitably equipped and properly trained personnel.

**3.7.3.2 A reference block,** of suitable material, for checking the gauge operation and to establish conditions for reproducible standard count rates. The reference block shall have the same serial number as the gauge and shall not be interchangeable between gauges.

NOTE The reference block should be kept clean and free from adhering particles which may cause poor contact with the gauge and result in an erroneous standard count rate.

**3.7.3.3 Gamma radiation monitor.**

**3.7.3.4 Test area preparation equipment,** i.e. suitable tools for levelling the ground at the site of the test, such as shovel, trowel and straightedge.

**3.7.3.5 Steel drill pin and hammer,** or auger, with suitable template for positioning the hole for the direct transmission test. The drive pin shall produce a hole up to 3 mm larger than the external diameter of the gauge probe.

NOTE This equipment is specified for making holes for the insertion of the probe in unstabilized materials and is also suitable for freshly laid stabilized materials. It may not, however, be suitable for hardened materials in which it may be necessary to bore a hole by means of a masonry drill.

**3.7.3.6 Gauge log**, containing standardization and stability test results.

**3.7.3.7 Calibration results** which may be in the form of charts and may be stored in the memory bank of the readout system.

**3.7.3.8 Dry fine quartz sand**, for bedding gauge on uneven surfaces.

**3.7.3.9 An electric vibrating hammer**, complying with 2.1.6.3.2 and fitted with a square or rectangular foot having an area between 7 500 mm<sup>2</sup> and 14 000 mm<sup>2</sup>.

**3.7.3.10 At least two cubical containers**, of rigid construction and having dimensions of 380 mm × 500 mm × 200 mm deep.

### 3.7.4 Calibration for bulk density determinations

**3.7.4.1 Manufacturer's bulk density calibration.** This calibration shall initially be carried out in accordance with ASTM D2922. Every 24 months the manufacturer's calibration shall be checked using not less than three standard density blocks as described in ASTM D2922.

**3.7.4.2 Initial site calibration for bulk density.** Calibrate the nuclear gauge in accordance with this clause for each type of transmission to be used for the test. The calibration procedure will depend upon the nature of the measurement application. These categories are as follows.

a) *Ground investigation comparative tests.* These tests require no initial site calibration, provided that the data obtained are used only for comparative purposes on the particular site. The test report shall clearly state that the comparative test method has been used.

b) *Compliance tests for compacted material.* Where the nuclear gauge is to be used for compliance tests on compacted material, carry out the initial site calibration by using a single container as specified in 3.7.4.3.1.

### 3.7.4.3 Material calibration for bulk density

**3.7.4.3.1 Calibration using blocks of material of known density**

**3.7.4.3.1.1** Measure the internal dimensions of the containers described in 3.7.3.10 to the nearest 1 mm and calculate their internal volumes. Weigh the containers and record their masses.

**3.7.4.3.1.2** Using the containers prepare at least two blocks of stabilized material using different masses of material in each. Prepare the blocks by compacting the stabilized material into the container(s) in four equal layers. Compact each layer with the vibrating hammer fitted with the foot. Scarify the surface of each layer before adding the next layer and finish the top layer flush with the top of the container by trowelling to a smooth surface. Form a hole 18 mm to 25 mm in diameter through the full depth of the block (200 mm) and normal to the surface. The hole shall be 125 mm from one end and in the centre of the 380 mm dimension. Use stabilized material with mix proportions similar to that proposed for the main works.

NOTE Blocks of material other than the stabilized material to be tested should not be used because the chemical composition is unlikely to be similar. However, it is recognized that they are of value to the manufacturer for ascertaining the initial settings of the gauge and have advantages for traceability requirements.

**3.7.4.3.1.4** Calculate the bulk density of the blocks from the dimensions and mass of each block.

NOTE The mass of the containers when filled with material is large. It may therefore be more convenient to weigh out suitable quantities of the mixed material beforehand into plastics bags. The total mass of the calibration block can then be calculated from the combined masses required for each of the separate layers of material. If the mass of material used in the construction of the block is known there is no need to determine the mass of the empty container.

**3.7.4.3.1.4** Within 1 h of weighing each block measure the bulk density with a nuclear gauge in the same manner as described for making site measurements of bulk density (see 3.7.8). If using the direct transmission mode take three density readings with the source rod lowered to a depth of 150 mm and the gauge in the same position. Determine the variation between the calculated density and the average of the three measured density values of each block as a percentage of the calculated density.

### 3.7.4.3.2 Derivation of the calibration

**3.7.4.3.2.1** If the difference between the variations for the two blocks is 1 % or less, then readings taken by nuclear density gauges used to measure the field density of the stabilized material shall be corrected by the average amount of the variation between the two blocks. Make the correction either by using the gauge biasing device in accordance with the gauge manufacturer's instructions or by multiplying the derived in-situ bulk density by the appropriate factor.

**3.7.4.3.2.2** If the difference between the variations for the two blocks is more than 1 % repeat the calibration. If this confirms the previous result consult the gauge manufacturer.



**3.7.4.3.2.3** Repeat the calibration every 3 months when testing is to continue for longer than this period.

### **3.7.5 Calibration for moisture density determinations**

**3.7.5.1** *Manufacturer's moisture density calibration.* This calibration shall initially be carried out in accordance with ASTM D3017. Every 24 months the manufacturer's calibration shall be checked by an authorized agent for the nuclear gauge.

**3.7.5.2** *Initial site calibration for moisture density.* Calibrate the nuclear gauge depending upon the nature of the measurement application as follows.

a) *Ground investigation comparative tests.* These tests require no initial site calibration, provided that the data obtained are used only for comparative purposes on the particular site. The test report shall clearly state that the comparative test method has been used.

b) *Ground investigation absolute tests.* Carry out an initial test before using the gauge at any site or when any significant change in the type of material occurs. Do this by selecting a suitable location and performing a minimum of two separate nuclear tests following the procedure given in **3.7.5.3** at different moisture densities spanning the range of expected use. For each nuclear test determine:

- 1) the quantity of water present per unit volume of the material from standard bulk density measurement other than the nuclear method; and
- 2) the moisture content by the definitive method described in **1.3.3**.

Compare the field density and moisture content results with the nuclear moisture density measurements. If each of the field tests varies by not more than  $0.01 \text{ Mg/m}^3$  of water from the nuclear result, and some of the field tests are greater and some less than the nuclear result then adjustment of the manufacturer's calibration is not necessary.

NOTE 1 Where the results all lie in one direction, some gauges include a facility for a constant adjustment.

Where there is a difference between the previous calibration and the check points that is greater than  $0.01 \text{ Mg/m}^3$  of water carry out a material calibration as described in **3.7.5.3**.

NOTE 2 Two calibration procedures are given using either containers or in-situ tests. Normally the container method is preferred.

NOTE 3 The alternative in-situ test methods may produce data with an inherent scatter that itself exceeds  $0.01 \text{ Mg/m}^3$  of water. It is therefore important to carry out enough alternative tests to provide reliable data. Where there is a doubt calibration using the container method should be carried out.

### **3.7.5.3 Material calibration for moisture density**

**3.7.5.3.1** *Calibration using blocks of material of known moisture density.* Place the stabilized material in the container as described in **3.7.4.3.1** in a manner to provide a uniform bulk density and moisture density. After the nuclear measurements calculate the bulk density of the stabilized material from the internal dimensions of the container and the mass of the wet stabilized material. Then take a representative sample of the material in the container to determine the moisture content of the material by the definitive method described in **1.3.3**. Calculate the moisture density, i.e. the mass of water present per unit volume of placed material.

#### **3.7.5.3.2** *Calibration of an in-situ location.*

Establish the calibration by using in-situ density tests such as those described in **3.3** and **3.4** and the moisture content of the in-situ material by the definitive method described in **1.3.3**. The method and test procedures used in obtaining the nuclear moisture density measurements shall be the same as those used to make a site measurement.

#### **3.7.5.3.3** *Derivation of the calibration*

**3.7.5.3.3.1** Use the two sets of data on moisture density, i.e. the count ratio or moisture density measurement by the existing gauge calibration and the results of the alternative test methods, to obtain the required calibration.

**3.7.5.3.3.2** The relation of best fit for normal moisture density is normally linear. Use the results of the analysis to adjust the manufacturer's calibration when this is incorporated in the gauge electronics.

**3.7.5.3.3.3** Where the new calibration points all lie uniformly on one side of the previous calibration this may be due to the presence of chemically bound water in the material. Some gauges include a facility to provide a constant adjustment of the result to suit such cases.

**3.7.5.3.3.4** Repeat calibrations for moisture density every three months when testing is to continue for a particular calibration for longer than this period.

### **3.7.6 Gauge standardization procedure**

NOTE All nuclear gauges are subject to long-term ageing of the sources, electronic components and the detectors. Geographically affected background radiation may vary, which can change the gauge performance. Gauges are therefore calibrated in terms of a ratio of the measurement count rate for each nuclear source to a count rate made on a reference block.

**3.7.6.1** Carry out the standardization of the gauge on the reference block for each type of measurement at the start and the end of each day's use. This procedure shall also be repeated after 8 h of continuous use, but may be carried out more frequently if appropriate. Retain a permanent record of these data. If the gauge is switched off repeat the standardization procedure.

**3.7.6.2** Switch on the gauge and allow for normalization, if required, in accordance with the gauge manufacturer's handbook. This period will usually be not less than 15 min. If the gauge is to be used either continuously or intermittently during the day, do not switch the gauge off. Perform the test with the gauge located at least 7 m away from other nuclear gauges and at least 1.5 m away from any large structure which may affect the gauge readings.

When it is necessary to use the gauge in a narrow trench or within 1.5 m of a building or other structure, take into account the effects of reflected radiation by determining the standard count rate with the reference block within 10 mm of each of the proposed test locations prior to each such test and use the same orientation as for the test. Always keep the gauge at least 150 mm clear of any vertical projection.

**3.7.6.3** Place the gauge on the reference block and ensure that the source rod is correctly located. For each type of measurement, i.e. bulk density and moisture density, take at least four consecutive readings over a measurement period of 1 min and calculate the mean value.

NOTE If available on the gauge a single measurement taken over a period of 4 min or more is acceptable.

This shall constitute one standardization check.

**3.7.6.4** Make a record of the results of each standardization check with the date of the measurements in the gauge log in order to retain a continuity of results.

**3.7.6.5** Check whether the arithmetical mean value in each case is within the limits set by the following equation and record the value of  $N_s$  in the gauge log.

$$N_s = N_o \pm 2.0 N_o p_c$$

where

$N_s$  is the average value of the current standard count rate;

$N_o$  is the average of four values of  $N_s$  taken prior to use;

$p_c$  is the amount of prescale applied to the detector counts prior to display.

NOTE The manufacturer should supply the value of  $p_c$ . If no prescale is built into the gauge  $p_c = 1$ .

Provided that  $N_s$  is within the limits permitted by the equation, use the  $N_s$  value to determine the count rate ratios for the current day's use of the gauge.

**3.7.6.6** If the value of  $N_s$  is outside the permitted limits repeat at least twice more the procedure for determining the average standard count rate. If all three, or two, of the three determinations are outside the acceptable limits withdraw the gauge from service until the fault is rectified.

**3.7.6.7** If the standardization at the end of the working period gives values outside the permitted limits all results with that working period shall be invalid.

### 3.7.7 Gauge stability procedure

Follow the gauge standardization procedure described in 3.7.6 but carry out a series of at least 16 repetitive measurements of 1 min with the gauge on the reference block for each type of measurement. Do not move the gauge during this process.

Separately record each of the measurements for each nuclear source in the gauge log with the date of the measurements.

Determine the standard deviation (SD) and determine the average value of each series of repetitive measurements.

Check that each stability ratio, expressed as the standard deviation divided by the square root of the average value, lies within the gauge manufacturer's quoted range for the gauge. Take into account any prescale value used and record the results in the gauge log.

Where either of the stability ratios fall outside the gauge manufacturer's specified range or the trend in successive checks is erratic withdraw the gauge from service until the fault is rectified.

NOTE Carry out this check on the gauge stability for each type of measurement at least once a month when in general daily use and once every 3 months otherwise. If the trend in successive checks is erratic the gauge should be withdrawn.

### 3.7.8 Test procedure for the determination of bulk density by direct transmission

**3.7.8.1** Standardize the gauge by the procedure described in 3.7.6. Perform the test with the gauge located at least 7 m away from other nuclear gauges and at least 1.5 m away from any large structure (large structures may affect the gauge readings).

When it is necessary to use the gauge in a narrow trench or within 1.5 m of a building or other structure, take into account the effects of reflected radiation by determining the standard count rate with the reference block within 10 mm of each of the proposed test locations prior to each such test. Always keep the gauge at least 150 mm clear of any vertical projection.

**3.7.8.2** Select an area for test as described in 3.2 and remove extraneous material from the test position, which shall be essentially flat and free from depressions.

**3.7.8.3** Using the template as a guide, drill or drive a hole to the appropriate depth. The depth of the hole may need to be greater than the depth over which the bulk density is to be determined (consult the gauge manufacturer's handbook for advice on the appropriate depth). Mark the surface in order to locate the gauge correctly with respect to the position of the hole for the probe.

**3.7.8.4** Place the gauge on the test site and ensure that there is good contact between the base of the gauge and the material under test. Where necessary maximise contact between the gauge base, which shall be kept clean and free of adhering particles, by using small quantities of fine dry sand, or fines of the material under test, to fill small surface voids. Ensure that this added material does not form a separate layer.

**3.7.8.5** Insert the probe to the selected depth and pull the gauge in the direction that will bring the probe against the side of the hole, closest to the detector location in the gauge housing.

**3.7.8.6** Obtain a gauge bulk density reading in accordance with the gauge manufacturer's handbook and, if required, a gauge moisture density reading (see 3.7.9), both with a minimum test period of 1 min. If desired, rotate the gauge about the axis of the probe and take further measurements. For the second determination rotate the gauge through 180° to the direction of the first measurement and average the two results. Alternatively, increase the volume of material measured by repeating the test at immediately adjacent (vertically or horizontally) locations and averaging the results. If the test is repeated in a vertically adjacent location and the results are to be averaged, the top of the second test shall be at the level of the depth selected for the insertion of the probe in the first test.

**3.7.8.7** Retract the movable probe securely into the housing.

**3.7.8.8** Read off from the gauge and record the nuclear field bulk density and, if required, the moisture density at the test site. Adjust the field values using the calibration charts.

NOTE Some gauges contain microprocessors capable of storing a user-determined calibration which automatically corrects the displayed data.

### 3.7.9 Test procedure for the determination of bulk density and moisture density by back scatter

NOTE The addition of moisture density measurements, with gauges that include this facility, may be taken at the same time as the bulk density measurements in either bulk density mode of the gauge. Where moisture density, as the mass of water per unit volume, is separately required, follow the procedure given in this clause but omit the operations concerning bulk density, including leaving the bulk density measurement in the safe position.

**3.7.9.1** Follow the procedure described in 3.7.8.1, 3.7.8.2 and 3.7.8.4.

**3.7.9.2** Follow the gauge manufacturer's handbook to obtain a gauge bulk density reading and gauge moisture density reading, both with a minimum test period of 1 min. If desired, rotate the gauge about the axis of the probe and take further measurements. For the second determination rotate the gauge through 180° to the direction of the first measurement and average the two results. Alternatively, increase the volume of material measured by repeating the test at immediately adjacent locations and averaging the two results.

**3.7.9.3** Retract the nuclear probe safely into the housing.

**3.7.9.4** Read off from the gauge and record the nuclear field bulk density and, if required, the moisture density at the test site. Adjust the field values using the calibration charts.

NOTE Some gauges contain microprocessors capable of storing a user-determined calibration which automatically corrects the displayed data.

### 3.7.10 Calculations and expression of results

**3.7.10.1 Dry density.** Calculate the dry density  $\rho_d$  (in  $\text{Mg/m}^3$ ) from the following equations:

a) for nuclear gauge determinations of moisture content:

$$\rho_d = \rho - W$$

where

$\rho$  is the bulk density of the material (in  $\text{Mg/m}^3$ ) determined with the nuclear gauge;

$W$  is the moisture density, i.e. the mass of water per unit volume of material determined with the nuclear gauge.

b) for laboratory determination of moisture content:

$$\rho_d = 100\rho/100 + w$$

where

$\rho$  is the bulk density of the material (in  $\text{Mg/m}^3$ ) determined with the nuclear gauge;

$w$  is the moisture content of the material (in %) as determined by the definitive method given in 1.3.3.

**3.7.10.2 Moisture content.** Calculate the moisture content  $w$  (as %) from the equation:

$$w = 100W/\rho - W$$

where

$W$  is the moisture density, i.e. the mass of water per unit volume of material determined with the nuclear gauge;

$\rho$  is the bulk density of the material (in  $\text{Mg/m}^3$ ) determined with the nuclear gauge.

### 3.8 Test report

The report shall affirm that the in situ density test was made in accordance with clause 3 of BS 1924-2:1990. The report shall contain the following results and general information:

- a) the method used to obtain the results;
- b) the in situ bulk and/or dry density of the stabilized material (in  $\text{Mg/m}^3$ ) to the nearest  $0.01 \text{ Mg/m}^3$ ;
- c) the moisture content (if determined) as a percentage to two significant figures;
- d) the test location and test number;
- e) the time-lapse between completion of compaction and the time at which the in situ density was determined;
- f) description of the stabilized material, i.e. type of material and stabilizer.

## Section 4. Strength and durability tests

### 4.1 Determination of the compressive strength of cylindrical specimens

NOTE This method is not suitable for use with coarse-grained materials as the size of mould which would be required would be very heavy to handle when filled with compacted material.

#### 4.1.1 Principle

Specimens of laboratory mixed stabilized material prepared as described in 6.3 of BS 1924-1:1990, or freshly mixed stabilized materials from the site (see note), are prepared by compacting the material into cylindrical moulds. After de-moulding the specimens are cured at constant moisture content and temperature for a set period to allow the stabilizer to harden. At the end of the curing period the specimens are crushed and the compressive strength calculated from the crushing force and cross-sectional area of the cylinders.

NOTE In the case of cement-stabilized materials preparation of the specimens should be completed within 2 h of mixing. Lime-stabilized materials may benefit by being allowed to "cure" before proceeding with the preparation of test specimens (see 6.3.3 of BS 1924-1:1990).

The requirements of BS 1924-1 shall where appropriate apply to this standard.

#### 4.1.2 Apparatus

##### 4.1.2.1 General apparatus

4.1.2.1.1 5 mm and 20 mm test sieves, for fine and medium-grained materials respectively.

4.1.2.1.2 A balance of 10 kg minimum capacity, readable to 1 g.

4.1.2.1.3 Tapered moulds, each having two steel plugs, for the preparation of specimens of the following dimensions (see note):

- a) for fine-grained materials: 100 mm high  $\times$  50 mm mean diameter (see Figure 17);
- b) for medium-grained materials: 200 mm high  $\times$  100 mm mean diameter (see Figure 19).

All parts of the moulds shall be strong enough to prevent distortion.

NOTE The specification has been written on the basis of internally tapered moulds being used. These have the advantage that they are very convenient to use, but if they are not available split moulds with the same dimensions but with cylindrical bores may be used in their place. The moulds should be lightly coated with oil before use.

4.1.2.1.4 Ejecting plungers and displacing collars, for use with the above moulds (see Figure 18 and Figure 20).

4.1.2.1.5 A compression testing machine, capable of exerting a force up to 500 kN and producing in a specimen a steady rate of axial deformation of approximately 1 mm/min. The platens shall be adequately supported over the area of contact with the specimens and when tested in accordance with BS 427 shall have a Vickers hardness value of not less than 550HV30. The surface flatness of the platens and the surfaces by which they are supported shall be 0.03 mm or better. The surface texture of the areas in contact with specimens shall be between 0.4  $\mu$ m and 3.2  $\mu$ m  $R_a$ . The upper platen shall be supported by a spherical seating designed to permit easy alignment of the platen to the specimen but to become immobile as the force on the specimen increases. Provision shall be made for positive location of specimens at the centre of the lower platens; visual alignment is not acceptable. The machine load indicators shall be verified in accordance with BS 1610-1, annually or when disturbance, adjustment or major repair may have affected the accuracy. Machines complying with grade 1 of BS 1610 are suitable.

4.1.2.1.6 A steel tamping rod, of suitable length and 5 mm to 15 mm in diameter.

4.1.2.1.7 Apparatus for moisture content determination by the oven-drying method described in 1.3.3.

4.1.2.1.8 A hide-faced or copper-faced hammer, of mass approximately 2 kg.

4.1.2.1.9 Metal funnel or scoop, to fit the neck of the moulds.

4.1.2.1.10 Calipers, readable to 0.1 mm with an opening not less than 100 mm when testing fine-grained materials or 200 mm when testing medium-grained materials.

4.1.2.2 Additional apparatus for specimens compacted to a constant compactive effort

4.1.2.2.1 A 50 mm diameter metal rammer, as used in the 2.5 kg rammer method described in 2.1.3.2.3 (see Figure 3).

4.1.2.2.2 A palette knife.

NOTE A convenient size is one having a blade 200 mm long and 30 mm wide.

4.1.2.2.3 A straightedge, e.g. a steel strip 300 mm long, 25 mm wide and 3 mm thick, with one bevelled edge.

#### 4.1.3 Material

4.1.3.1 Paraffin wax, or other suitable wax or plastics sheeting for coating the test specimens to maintain them at constant moisture content (see 4.1.6).

NOTE If wax is used suitable equipment in which to melt the wax will be needed.

#### 4.1.4 Preparation of specimens compacted to a pre-determined density

**4.1.4.1** Either mix the material with the water and stabilizer as described in **6.3** of BS 1924-1:1990 or obtain a sample of the mixed material from the site by the procedure described in **5.3** of BS 1924-1:1990.

**4.1.4.2** Sieve the mixed material on the 5 mm test sieve for fine-grained materials or the 20 mm test sieve for medium-grained materials and use only the fraction passing the appropriate sieve for the preparation of the specimens.

**4.1.4.3** Calculate the mass ( $m_1$ , in g) of the stabilized material required for moulding into a specimen of the required dry density in accordance with the mould used, from the appropriate equation as follows:

a) for fine-grained materials (100 mm × 50 mm moulds):

$$m_1 = (196.4 + 1.964 w) \rho_d$$

b) for medium-grained soils (200 mm × 100 mm moulds):

$$m_1 = (1571 + 15.71 w) \rho_d$$

where

$w$  is the moisture content of the stabilized material (in %);

$\rho_d$  is the dry density of the stabilized material (in Mg/m<sup>3</sup>).

**4.1.4.4** Carry out one of the following procedures.

a) Place the appropriate mass of material in the mould into which, using a displacing collar, the lower plug has been inserted to a distance of 15 mm. During filling tamp the material gently and uniformly so that the upper plug can be inserted to a distance of about 15 mm. Insert the upper plug and place the mould assembly in the compression device or testing machine. After removal of the displacing collars apply a compressive force to the plugs until the flanges are in contact with the barrel of the mould. After the force has been maintained for about 0.5 min release the force and remove the mould from the press. Then remove the plugs from the mould. Insert the plunger into the end of the mould having the smaller diameter and release the specimen from the taper by gentle hammering or pressure. Remove the specimen from the top of the plunger and determine its mass ( $m_2$ ) to the nearest 1 g (see note).

b) Follow the procedure given in a) except that the specimen shall be compacted by driving home the end plugs with a hide-faced or copper-faced hammer (see note).

**NOTE** When dealing with cohesive materials it is possible to remove the specimen from the mould immediately after preparation. However, with non-cohesive materials it may be advantageous to allow the specimen to remain in the mould until it has developed enough strength for it to be handled; 24 h is generally sufficient. If the specimens are to be coated in wax (see **4.1.6**) they can be handled immediately if a cradle is made which allows the specimens to be transferred from the mould to the cradle and then dipped in molten wax. Once the wax has hardened the specimens can be handled without difficulty.

#### 4.1.5 Preparation of specimens compacted with constant compactive effort

**4.1.5.1** Either mix the material with the water and stabilizer as described in **6.3** of BS 1924-1:1990 or obtain a sample of the mixed material from the site by the procedure described in **5.3** of BS 1924-1:1990.

**4.1.5.2** Sieve the mixed material on the 5 mm test sieve for fine-grained materials or the 20 mm test sieve for medium-grained materials and use only the fraction passing the appropriate sieve for the preparation of the specimens.

**4.1.5.3** For fine-grained materials proceed as follows.

Insert the appropriate plug into the bottom of the mould, i.e. the larger diameter uppermost, and add to the mould a quantity of the material sufficient to give a specimen length of 100 mm to 110 mm after compaction, i.e. about 450 g for most naturally occurring materials. Tamp the material gently and uniformly with the tamping rod during the operation.

Insert the other plug into the mould, and compact the material by 15 blows of the rammer dropped from a height of 300 mm on to the plug.

**NOTE** This plug should not have been fully driven home at this stage; if it has, then there is insufficient material in the mould.

Invert the mould containing the specimen and replace the uppermost plug by the plunger. The material shall then be further compacted by 15 blows from the rammer applied to the plunger.

Reject the compacted specimen for subsequent testing if its length exceeds 110 mm. Insert the plunger into the end of the mould having the smaller diameter and release the specimen from the taper by gentle hammering or pressure. Remove the specimen from the mould and determine its mass ( $m_2$ ) to the nearest 1 g [see note to **4.1.4.4 b**].

**4.1.5.4** For medium-grained materials proceed as follows.

Insert the appropriate plug into the bottom of the mould, i.e. the larger diameter uppermost, and compact a quantity of material sufficient to give a specimen of 200 mm to 210 mm after compaction, i.e. about 3.5 kg for most naturally occurring materials, into the mould in six equal layers. Give each layer 25 blows of the rammer dropped from a height of 300 mm above the stabilized material. Distribute the blows uniformly over the surface of each layer, and scarify with the palette knife before the next layer is added. Reject the compacted specimen for subsequent testing if its length exceeds 210 mm.

Insert the plunger into the end of the mould having the smaller diameter and release the specimen from the taper by gentle hammering or pressure. Extrude any length in excess of 200 mm beyond the mould. Gauge this length by placing the 200 mm long displacing collars on the plunger. Carefully level off the face of the specimen to the end of the mould using the straightedge and fill any irregularities with fine material from the same sample. Remove the specimen from the mould and determine its mass ( $m_2$ ) to the nearest 1 g [see note to 4.1.4.4 b)].

#### 4.1.6 Curing

After removing the specimens from the moulds coat them with wax (see note 1) to maintain them at their specified moisture content. Take care not to leave holes in the wax film and to complete the coating as quickly as possible to prevent absorption of the wax. After coating with wax determine the mass ( $m_3$ ) to the nearest 1 g and store until required (see note 2) at a constant temperature of  $20 \pm 2$  °C (see note 3).

**NOTE 1** During the curing period it is essential that the specimens do not lose any water. Coating with wax has been specified as this has been found to be the best method of maintaining the moisture content of a specimen at a constant value, is very simple to carry out and the wax can be re-used. To simplify its removal from a specimen, the wax should be used as cool as possible. If it is not possible to coat the specimens with wax they should be wrapped carefully in thin plastics sheeting and transferred to sealed airtight plastics bags of a size just sufficient to hold a single specimen. In the case of stabilized specimens prepared from washed and graded aggregates, e.g. lean concrete (CBM3) specimens, it is acceptable to cure them by allowing them to harden in their moulds for 24 h and then to cure them totally immersed under water at  $20 \pm 2$  °C until required. This is the method normally used for curing test specimens of concrete and tests have shown that it is an acceptable alternative for curing stabilized specimens prepared from granular materials free from cohesive fines.

**NOTE 2** After the specimens have been removed from the moulds they have to be allowed to cure for a sufficient time for strength to develop. Tests are therefore normally carried out on specimens that have been stored for various periods to determine whether or not the strength is increasing satisfactorily. With cement-stabilized materials suitable periods for storage are 3, 7, 14 and 28 days whilst for lime-stabilized materials periods of 7, 28, 56 and 112 days might be more appropriate. However, in many cases tests are made on specimens that have been stored for a single fixed period, the time chosen depending on the process of stabilization under consideration. With cement-stabilized materials this period is normally 7 days and for lime-stabilized materials it is normally 28 days.

**NOTE 3** The curing temperature of  $20 \pm 2$  °C applies in temperate climates. For areas with tropical and subtropical climates a curing temperature of  $27 \pm 2$  °C is more appropriate. The tolerance on the curing temperature of  $\pm 2$  °C is essential for all laboratory work and for preliminary testing to ascertain the cement content required. For site conditions where strength tests are being made for quality control purposes, however, the tolerances may be relaxed to  $\pm 5$  °C. If this is done the maximum and minimum curing temperatures should be ascertained and reported with the results.

#### 4.1.7 Crushing procedure

**4.1.7.1** After the curing period and before testing weigh each specimen and record its mass ( $m_4$ ) to the nearest 1 g. Discard any specimen 100 mm high  $\times$  50 mm in diameter which has lost more than 4 g in mass and any specimen 200 mm high  $\times$  100 mm in diameter which has lost more than 12 g in mass during the curing period.

**4.1.7.2** After weighing carefully remove the wax from the specimen; take care not to damage the surface. Keep the wax for subsequent re-use.

**4.1.7.3** Measure and record the length ( $L$ ) of the specimen to the nearest 0.1 mm using the calipers and the steel rule.

**4.1.7.4** Place the specimen centrally on the lower platen of the compression testing machine and apply the force to the ends of the specimen so that the rate of deformation is uniform and approximately 1 mm/min. Record the maximum force ( $p$ , in N) exerted by the machine during the test.

**4.1.7.5** If required, determine the moisture content ( $w_2$ ) of a representative sample of fragments taken from the interior of the specimen by one or other of the methods given in clauses 1.4.4 to 1.4.6.

**NOTE** The moisture content determined at this stage will usually differ from the initial moisture content because some of the water will have been removed by hydration and pozzolanic reactions even if no losses due to evaporation have occurred.

#### 4.1.8 Calculations and expression of results

**NOTE** A typical data and calculation form for the determination of the compressive strength is given in form L of Appendix A.

**4.1.8.1** Calculate the compressive strength ( $P$ , in MPa) of each specimen from the appropriate equation as follows:

- a) for specimens 50 mm in diameter and 100 mm long:  $P = 0.00051_p$ ;
- b) for specimens 100 mm in diameter and 200 mm long:  $P = 0.0001275_p$

where  $p$  is the maximum recorded load (in N).

Record values of the compressive strength up to 2 MPa to the nearest 0.02 and values above 2 MPa to the nearest 0.05.

**4.1.8.2** Calculate the mean unconfined compressive strength of the set of specimens tested recording the mean value as given in **4.1.8.1**.

**4.1.8.3** If required calculate the initial dry density ( $\rho_d$ , in Mg/m<sup>3</sup>) of the specimens from the appropriate equation as follows:

- a) for specimens 50 mm in diameter and 100 mm long:  $\rho_d = 50.92 m_2/L (100 + w_1)$ ;
- b) for specimens 100 mm in diameter and 200 mm long:  $\rho_d = 12.73 m_2/L (100 + w_1)$

where

$m_2$  is the mass of the specimen before coating with wax (in g);

$L$  is the length of the specimen (in mm);

$w_1$  is the initial moisture content of the stabilized material (in %).

Record values of dry density to the nearest 0.01 Mg/m<sup>3</sup> and of moisture content to two significant figures.

**4.1.8.4** if required calculate the dry density ( $\rho_d$ , in Mg/m<sup>3</sup>) of the specimen as tested from the appropriate equation as follows:

- a) for fine-grained materials:

$$\rho_d = \frac{50.92(m_2 - m_3 + m_4)}{L(100 + w_2)}$$

- b) for medium-grained materials:

$$\rho_d = \frac{12.73(m_2 - m_3 + m_4)}{L(100 + w_2)}$$

where

$m_2$  is the mass of specimen before coating with wax (in g);

$m_3$  is the mass of specimen after coating with wax (in g);

$m_4$  is the mass of specimen after curing (in g).

NOTE The equations in **4.1.8.3** and **4.1.8.4** are applicable only to specimens which have been coated with wax. If other methods of curing were used the equations need to be adjusted to take account of this.

#### 4.1.9 Test report

The test report shall affirm that the compressive strength was determined in accordance with **4.1** of BS 1924-2:1990 and whether or not a certificate of sampling is available. If available a copy of the certificate of sampling shall be provided. The test report shall contain the following additional information:

- a) sample identification;
- b) the mean compressive strength of the set of specimens, together with the results for the individual specimens;
- c) the moisture content and dry density at which the specimens were prepared and/or the moisture content and dry density at which they were tested;
- d) the age at which the specimens were tested;
- e) the size and shape of the test specimens.

## 4.2 Determination of the compressive strength of cubic specimens

### 4.2.1 Principle

Specimens of laboratory mixed stabilized material prepared as described in clause **6.3** of BS 1924-1:1990, or freshly mixed stabilized materials from the site (see note), are prepared by compacting the material into cubic moulds. After de-moulding the specimens are cured at constant moisture content and temperature for a set period to allow the stabilizer to harden. At the end of the curing period the specimens are crushed and the compressive strength calculated from the crushing force and cross-sectional area of the cubes.

NOTE In the case of cement-stabilized materials preparation of the specimens should be completed within 2 h of mixing. Lime-stabilized materials may benefit by being allowed to "cure" before proceeding with the preparation of test specimens (see clause **6.3** of BS 1924-1:1990).

The requirements of BS 1924-1 shall where appropriate apply to this test method.

### 4.2.2 Apparatus

#### 4.2.2.1 Apparatus for all methods

**4.2.2.1.1** 5 mm, 20 mm and 27.5 mm test sieves, for fine, medium and coarse-grained material respectively.

**4.2.2.1.2** A balance, of 10 kg minimum capacity, readable to 1 g.

**4.2.2.1.3** Moulds, suitable for casting 150 mm cubes, manufactured in accordance with BS 1881-108.

**4.2.2.1.4** A plasterer's steel trowel.

**4.2.2.1.5** Curing tins, with well fitting lids and suitable sealing tape.



NOTE Tins of 160 mm × 160 mm × 155 mm in size are a convenient means of storing the cubes whilst they are curing and help to protect them from damage. If they are not available close fitting airtight plastics bags may be used (see also 4.2.6).

**4.2.2.1.6** A *compression testing machine*, that meets the requirements of BS 1881-115, capable of exerting sufficient force for the tests and of providing a uniform rate of increase of stress in the test specimen of approximately 3.5 MPa/min.

**4.2.2.1.7** A *palette knife*.

NOTE A convenient size is one having a blade 200 mm long and 300 mm wide.

**4.2.2.1.8** *Flat metal plates*, measuring approximately 200 mm × 200 mm × 3 mm, or other suitable means of preventing loss of moisture from the top of cube moulds.

**4.2.2.1.9** *Apparatus for moisture content determination* by the oven-drying method described in 1.3.3.

**4.2.2.2** *Additional apparatus for specimens compacted to a pre-determined dry density*

**4.2.2.2.1** *An electric or pneumatic vibrating hammer*.

NOTE Electric vibrating hammers as described in 2.1.6.3.2 or pneumatic vibrating hammers of similar performance are suitable.

**4.2.2.2.2** *A square tamper*, approximately 8100 mm<sup>2</sup> in area for use with the vibrating hammer, having a collar rigidly and accurately attached to its shank so that the tamper foot is prevented from entering the mould further than 50 mm (see Figure 21).

**4.2.2.2.3** *A square tamper*, as in 4.2.2.2.2, with entry into the mould limited to 100 mm.

**4.2.2.2.4** *A square tamper*, as in 4.2.2.2.2, with entry into the mould limited to 150 mm.

**4.2.2.3** *Additional apparatus for specimens compacted to a constant compactive effort*

**4.2.2.3.1** *A metal rammer*, having a 45 mm square face, a mass of 4.5 kg and a controlled drop of 450 ± 4 mm (see Figure 22).

**4.2.2.3.2** *A straightedge*, e.g. a steel strip 300 mm long, 25 mm wide and 3 mm thick, with one bevelled edge.

**4.2.2.4** *Additional apparatus for specimens compacted to refusal*

**4.2.2.4.1** *An electric or pneumatic vibrating hammer*.

NOTE Electric vibrating hammers as described in 2.1.6.3.2 or pneumatic vibrating hammers of similar performance are suitable.

**4.2.2.4.2** *A square tamper*, approximately 7 200 mm<sup>2</sup> in area for use with the vibrating hammer.

**4.2.2.4.3** *A straightedge*, e.g. a steel strip 300 mm long, 25 mm wide and 3 mm thick, with one bevelled edge.

**4.2.3** **Preparation of specimens compacted to a pre-determined density**

**4.2.3.1** Either mix the material with the water and stabilizer as described in 6.3 of BS 1924-1:1990 or obtain a sample of the mixed material from the site by the procedure described in 5.3 of BS 1924-1:1990.

**4.2.3.2** Sieve the mixed material on the 5 mm test sieve for fine-grained materials, the 20 mm test sieve for medium-grained materials or the 37.5 mm test sieve for coarse-grained materials and use only the fraction passing the appropriate sieve for the preparation of the specimens.

**4.2.3.3** Calculate the mass ( $m_1$ , in g) of stabilized material required for moulding into a specimen of the required dry density from the equation:

$$m_1 = \rho_d (3375.0 + 33.75w_1)$$

where

$w_1$  is the moisture content of the stabilized material (in %);

$\rho_d$  is the dry density of the stabilized material (in Mg/m<sup>3</sup>).

**4.2.3.4** Divide the material of mass  $m_1$  into three approximately equal parts by mass. Place one of the parts in an assembled mould and level off the surface. Using a tamper fitted with a collar at the 100 mm mark and a vibrating hammer, compact the material uniformly until the collar comes into contact with the upper surface of the mould. Scarify the surface of the layer with the palette knife before adding the next layer and compacting it in a similar manner to the first layer, but using a collar at the 50 mm position. Place a 150 mm cube mould, without the baseplate, squarely on top of the mould, scarify the compacted layer with the palette knife, and add the final layer using the tamper with the collar at the 150 mm position. Remove the upper mould and then level off the surface of the specimen carefully to the end of the mould using the trowel and vibrating tamper, care being taken not to spill any loose material during this final operation. Cover the mould containing the specimen with a metal plate and store at a temperature of 20 ± 2 °C (see note 3 to 4.1.6) until the following day, then remove the specimen from the mould for further curing. Weigh the specimen and record its mass ( $m_2$ ) to the nearest 1 g.

#### 4.2.4 For specimens compacted to a constant compactive effort

4.2.4.1 Either mix the material with the water and stabilizer as described in 6.3 of BS 1924-1:1990 or obtain a sample of the mixed material from the site by the procedure described in 5.3 of BS 1924-1:1990.

4.2.4.2 Sieve the mixed material on the 5 mm test sieve for fine-grained materials, the 20 mm test sieve for medium-grained materials or the 37.5 mm test sieve for coarse-grained materials and use only the fraction passing the appropriate sieve for the preparation of the specimens.

4.2.4.3 Assemble the mould on its baseplate and place another mould, without the baseplate, squarely on top. Compact a quantity of material sufficient to give a specimen of 150 mm to 160 mm depth after compaction, i.e. about 8 kg for most naturally occurring materials, into the mould in three equal layers. Give each layer 35 blows of the rammer dropped from a height of 450 mm above the stabilized material. Distribute the blows uniformly over the surface of each layer and scarify with the palette knife before the next layer is added. Reject the compacted specimen for subsequent testing if its height exceeds 160 mm.

4.2.4.4 After removing the upper mould strike off excess material level with the top of the lower mould and check with the straightedge, and fill any irregularities with fine material from the same sample. Cover the mould containing the specimen with a metal plate and store at a temperature of  $20 \pm 2$  °C (see note 3 to 4.1.6) until the following day, then remove the specimen from the mould for further curing. Weigh the specimen and record its mass ( $m_2$ ) to the nearest 1 g.

#### 4.2.5 For specimens compacted to refusal

4.2.5.1 Either mix the material with the water and stabilizer as described in 6.3 of BS 1924-1:1990 or obtain a sample of the mixed material from the site by the procedure described in 5.3 of BS 1924-1:1990.

4.2.5.2 Sieve the mixed material on the 5 mm test sieve for fine-grained materials, the 20 mm test sieve for medium-grained materials or the 37.5 mm test sieve for coarse-grained materials and use only the fraction passing the appropriate sieve for the preparation of the specimens.

4.2.5.3 Assemble the mould on its baseplate and place another mould, without the baseplate, squarely on top. Compact a quantity of material sufficient to give a specimen of 150 mm to 160 mm depth after compaction, i.e. about 8 kg for most naturally occurring materials, into the mould in three approximately equal layers. Compact each layer with a tamper fitted to a vibrating hammer until it is judged that no further compaction is possible. Scarify each layer with the palette knife before the next layer is added. Reject the compacted specimen for subsequent testing if its height exceeds 160 mm.

4.2.5.4 After removing the upper mould strike off excess material level with the top of the lower mould and check with the straightedge, and fill any irregularities with fine material from the same sample. Cover the mould containing the specimen with a metal plate and store at a temperature of  $20 \pm 2$  °C (see note 3 to 4.1.6) until the following day, then remove the specimen from the mould for further curing. Weigh the specimen and record its mass ( $m_2$ ) to the nearest 1 g.

#### 4.2.6 Curing

During the curing period it is essential that the specimens do not lose any water. After removing the specimen from the mould place one of the curing tins specified in 4.2.2.1.5 (see note 1) over the specimen and then invert the tin with the specimen inside. Place the lid in position and seal with a suitable tape. Weigh the tin and the specimen, record the mass ( $m_3$ ) to the nearest 1 g and store until required (see note 2) at a constant temperature of  $20 \pm 2$  °C (see note 3 to 4.1.6).

NOTE 1 Storage in a sealed tin with dimensions slightly larger than the cubes has been found to be a good method of maintaining the moisture content at constant value, is very simple to carry out and protects the cubes from damage. If suitable tins are not available close-fitting airtight plastics bags may be used.

In the case of stabilized specimens prepared from washed and graded aggregates, e.g. lean concrete (CBM3) specimens, it is acceptable to cure them by allowing them to harden in their moulds for 24 h and then to cure them totally immersed under water at  $20 \pm 2$  °C until required. This is the method normally used for curing test specimens of concrete and tests have shown that it is an acceptable alternative for curing stabilized specimens prepared from granular materials free from cohesive fines.

NOTE 2 After the specimens have been removed from the moulds they have to be allowed to cure for a sufficient time for strength to develop. Tests are therefore normally carried out on specimens that have been stored for various periods to determine whether or not the strength is increasing satisfactorily. With cement-stabilized materials suitable periods for storage are 3, 7, 14 and 28 days whilst for lime-stabilized materials periods of 7, 28, 56 and 112 days might be more appropriate. However, in many cases tests are made on specimens that have been stored for a single fixed period, the time chosen depending on the process of stabilization under consideration. With cement-stabilized materials this period is normally 7 days and for lime-stabilized materials it is normally 28 days.

#### 4.2.7 Crushing procedure

**4.2.7.1** After the curing period and before testing weigh the tin and specimen and record the mass ( $m_4$ ) to the nearest 1 g. Discard any specimen which has lost more than 25 g in mass during the curing period.

**4.2.7.2** Place the specimen centrally on the lower platen of the compression testing machine in such a manner that the force is applied to the opposite sides of the cubes as cast, i.e. not to the top and the bottom. Apply the force without shock and increase continually at a rate of between 2.5 and 4.5 MPa/min until the resistance of the cube to the increasing force breaks down and no greater force can be sustained. Record the maximum force ( $p$ , in N) exerted by the machine during the test.

**4.2.7.3** If required, determine the moisture content ( $w_2$ ) of a representative sample of fragments taken from the interior of the specimen by one or other of the methods given in clauses 1.3.3 to 1.3.5.

NOTE The moisture content determined at this stage will usually differ from the initial moisture content because some of the water will have been removed by hydration and pozzolanic reactions even if no losses due to evaporation have occurred.

#### 4.2.8 Calculations and expression of results

**4.2.8.1** Calculate the compressive strength ( $P$ , in MPa) of each specimen from the equation:

$$P = 0.000044 p$$

where

$p$  is the maximum recorded load (in N).

Record values of the compressive strength up to 2 MPa to the nearest 0.02 MPa and values above 2 MPa to the nearest 0.05 MPa.

**4.2.8.2** Calculate the mean unconfined compressive strength of the set of specimens tested recording the mean value as given in 4.2.8.1.

**4.2.8.3** If required calculate the initial dry density ( $\rho_d$ , in Mg/m<sup>3</sup>) of the specimens from the equation:

$$\rho_d = 0.0296 m_2 / (100 + w_1)$$

where

$m_2$  is the mass of the specimen immediately after preparation (in g);

$w_1$  is the initial moisture content of the stabilized material (in %).

Record values of dry density to the nearest 0.01 Mg/m<sup>3</sup> and of moisture content to two significant figures.

**4.2.8.4** If required calculate the dry density ( $\rho_d$ , in Mg/m<sup>3</sup>) of the specimen as tested from the equation:

$$\rho_d = 0.0296(m_2 - m_3 + m_4) / (100 + w_2)$$

where

$m_2$  is the mass of specimen immediately after preparation (in g);

$m_3$  is the mass of specimen + tin before curing (in g);

$m_4$  is the mass of specimen + tin after curing (in g).

NOTE The equations in 4.2.8.3 and 4.2.8.4 are applicable only to specimens which have been cured in tins. If other methods of curing were used the equations need to be adjusted to take account of this.

#### 4.2.9 Test report

The test report shall affirm that the compressive strength was determined in accordance with 4.2 of BS 1924-2:1990 and whether or not a certificate of sampling is available. If available a copy of the certificate of sampling shall be provided. The test report shall contain the following additional information:

- sample identification;
- the mean compressive strength of the set of specimens, together with the results for the individual specimens;
- the moisture content and dry density at which the specimens were prepared and/or the moisture content and dry density at which they were tested;
- the age at which the specimens were tested;
- the size and shape of the test specimens.

### 4.3 Determination of the effect of immersion in water on the compressive strength

#### 4.3.1 Principle

Two identical sets of specimens are prepared both of which are cured in the normal manner at constant moisture content for 7 days. At the end of the 7 day period one set is immersed in water for 7 days whilst the other set continues to cure at constant moisture content. When both sets are 14 days old they are crushed and the strength of the set immersed in water as a percentage of the strength of the set cured at constant moisture content is calculated. This index  $R_i$  is a measure of the resistance to the effect of water on strength.

NOTE The test is not usually applied to specimens prepared from washed and graded aggregates as the processing will usually have removed harmful components. Moreover as specimens from such materials are usually cured under water any loss of strength due to immersion is automatically taken into account.

The requirements of BS 1924-1 shall where appropriate apply to this test method.

#### 4.3.2 Apparatus

4.3.2.1 *Apparatus*, as described in 4.1 or 4.2.

4.3.2.2 *A watertight tank*, preferably with a lid, in which several test specimens may be stored immersed in water with their top surface 25 mm below the surface of the water.

#### 4.3.3 Preparation of specimens

Prepare two sets of specimens at the same time, if possible from the same mix (see note) with a minimum of three specimens in each set. Prepare the specimens by one of the methods given in 4.1 or 4.2 for the determination of compressive strength and allow to cure as specified for 7 days. Do not cure the specimens under water.

NOTE If it is not practicable to prepare all the specimens from one mix, prepare at least two specimens from each separate mix and allocate one of each to the two independent sets.

#### 4.3.4 Test procedure

4.3.4.1 After curing for 7 days determine the mass ( $m_4$ ), to the nearest 1 g, of each specimen in one set of specimens. Discard any specimen that has lost more than 4 g in the case of cylindrical specimens of fine-grained material, 10 g in the case of cylindrical specimens of medium-grained material and 25 g in the case of cubes, and prepare fresh specimens if necessary. Remove the wax from the specimens or take out of the curing tins, whichever applies, taking care not to damage the specimens.

4.3.4.2 Totally immerse the set of specimens in water, in a tank, in such a way that the upper surfaces of the specimens are at least 25 mm below the surface of the water. Keep the specimens in this condition at a temperature of  $20 \pm 2$  °C (see note 3 to 4.1.6) for a further 7 days. At the end of this period remove them from the water and dry the surfaces with blotting or other similar absorbent paper. For cylindrical specimens measure and record the length ( $L$ ) of each to the nearest 0.1 mm with the calipers, determine its mass ( $m_5$ ) and treat as described in 4.3.4.4. Note the appearance of the specimens and record whether any show signs of cracking or volume expansion.

4.3.4.3 After curing for 14 days determine the mass ( $m_6$ ), to the nearest 1 g, of each specimen in the second set of specimens. Discard any specimen that has lost more than 4 g in the case of cylindrical specimens of fine-grained material, 10 g in the case of cylindrical specimens of medium-grained material and 25 g in the case of cubes, and prepare fresh specimens if necessary. Remove the wax from the specimens or take out of the curing tins, whichever applies, taking care not to damage the specimens. For cylindrical specimens measure and record the length ( $L$ ) to the nearest 0.1 mm with the calipers. Treat as described in 4.3.4.4.

4.3.4.4 Determine the compressive strength of the two sets of specimens by the procedures described in 4.1 or 4.2. Note the maximum forces in newtons exerted by the machine during the tests and record as  $p_i$  and  $p_c$  for the immersed and control specimens respectively.

4.3.4.5 Take representative samples of fragments of the specimens immediately after crushing and determine the moisture contents  $w_i$  or  $w$  by the procedure described in 1.3.3.

#### 4.3.5 Calculations and expression of results

NOTE A typical data and calculation form for the determination of the effect of immersion in water on compressive strength is given in form M of Appendix A.

4.3.5.1 Calculate the mean compressive strengths ( $P_i$  and  $P_c$  respectively, in MPa) of the two sets of specimens by the procedures given in 4.1.8 or 4.2.8.

4.3.5.2 Calculate the resistance to loss in strength ( $R_i$ ) as a percentage from the equation:

$$R_i = 100 P_i/P_c$$

where

$P_i$  is the mean compressive strength of the immersed specimens (in MPa);

$P_c$  is the mean compressive strength of the control specimens (in MPa).

4.3.5.3 Report the result to the nearest percent.

4.3.5.4 Calculate the original dry density ( $P_d$ , in  $\text{Mg/m}^3$ ) of the immersed specimens from the appropriate equation as follows:

a) for fine-grained materials (100 mm  $\times$  50 mm cylinders):

$$\rho_d = 50.92 m_5/L (100 + w_1);$$

b) for medium-grained materials (200 mm  $\times$  100 mm cylinders):

$$\rho_d = 12.73 m_5/L (100 + w_1);$$

c) for fine, medium and coarse-grained materials (150 mm cubes):

$$\rho_d = 0.0296 m_5 / (100 + w_1);$$

where

$m_5$  is the mass of the specimen after immersion (in g);

$L$  is the length of cylindrical specimen (in mm);

$w_1$  is the moisture content of the stabilized material after immersion (in %).

4.3.5.5 Calculate the dry density of the control specimens from the appropriate equation given in 4.1.8 or 4.2.8.

#### 4.3.6 Test report

The test report shall affirm that the effect of immersion in water on the compressive strength was determined in accordance with 4.3 of BS 1924-2:1990 and whether or not a certificate of sampling is available. If available a copy of the certificate of sampling shall be provided. The test report shall contain the following additional information:

- sample identification;
- the resistance to loss in strength ( $R_i$ ) and the individual results for the compressive strength of both sets of specimens;
- the moisture content and the dry density at which the specimens were prepared and/or the moisture content at which they were tested;
- the size and shape of the test specimens;
- whether or not the set of specimens soaked in water exhibited any signs of cracking or volume expansion.

## 4.4 Determination of the tensile splitting strength

NOTE This method is based on that given in BS 1881-117, which recommends that either 150 mm  $\times$  150 mm cylindrical specimens or 150 mm cubic specimens should be used. The method included in this clause relates only to cubic specimens, as suitable moulds of sufficient strength for preparing 150 mm  $\times$  150 mm cylindrical specimens by the compaction methods specified in this standard are not commercially available.

### 4.4.1 Principle

Cubic specimens of stabilized material are placed in a rig and compressed in such a way that they split into two halves [see Figure 23(a)]. The force required to split the cubes is a function of the tensile strength of the material.

The requirements of BS 1924-1 shall where appropriate apply to this test method.

### 4.4.2 Apparatus

NOTE Either apparatus A (which may also be used for cylindrical specimens tested in accordance with BS 1881) or apparatus B should be used.

#### 4.4.2.1 Components of apparatus A and B

4.4.2.1.1 *Compression testing machine*, complying with BS 1881-115.

4.4.2.1.2 *Jig*. The jig and/or the machine shall have a device to position the jig correctly on the lower platen, with the specimen central.

NOTE Suitable jigs are shown in Figure 23(a) and Figure 23(b).

#### 4.4.2.2 Additional components of apparatus A

4.4.2.2.1 *Packing strips*. Use hardboard packing strips between the specimen and jigs or steel loading pieces. Packing strips shall be oil-tempered grade hardboard complying with BS 1142 and shall be used only once.

They shall have the following dimensions [see Figure 23(a)]:

- width:  $a = 15 \pm 2$  mm;
- thickness:  $t = 4 \pm 1$  mm;
- length: greater than the length of line of contact of the test specimen.

4.4.2.2.2 *Steel loading pieces*. Place a steel loading piece between the platen of the machine and the hardboard packing strip. This piece shall not be shorter than the specimen. For cubic specimens it shall be a section of a cylinder, with a radius of 75 mm, so that the load is applied along a line on the surface of the specimen (see Figure 23). This loading piece can be incorporated within the jig. The tolerances on the dimensions shall be as specified in 4.4.2.4.

#### 4.4.2.3 Additional components of apparatus B

**4.4.2.3.1 Steel loading pieces.** Steel loading pieces shall be auxiliary platens incorporating steel strips with the following dimensions [see Figure 23(b)]:

- a) width:  $a = 6 \pm 1$  mm (for 150 mm size specimens);
- b) thickness:  $t = 4 \pm 1$  mm;
- c) length: not less than the length of line of contact with the test specimen.

The tolerances shall be as specified in 4.4.2.4.

**4.4.2.4 Tolerances.** The steel loading pieces specified in 4.4.2.2.2 and 4.4.2.3.1 shall have the flatness, parallelism and surface requirements along the length of the strips within the tolerances for auxiliary platens given in BS 1881-115. The steel loading pieces shall be replaced when the dimensions are out of tolerance or when they are seriously damaged or pitted along the contact face.

#### 4.4.3 Preparation of the test specimens

**4.4.3.1** Prepare the test specimens and allow them to cure for the required period by one or other of the methods described in 4.2.

**4.4.3.2** After curing check the mass of the specimens as described in 4.2.7.1.

#### 4.4.4 Splitting procedure

**4.4.4.1 Preparation for testing.** Wipe clean the bearing surfaces of the testing machine, the steel loading pieces and the packing strips; remove any loose material from the surfaces of the test specimen which are to be in contact with the packing strips.

**4.4.4.2 Positioning of the test specimen** (see Figure 23). Place the test specimen in the centring jig with the packing strips and/or loading pieces carefully positioned along the top and bottom of the plane of loading of the specimen. Then place the jig in the machine so that the specimen is located centrally. In the case of prismatic and cubic specimens, the load shall be applied on the moulded faces in such a way that the fracture plane will cross the trowelled surface (see Figure 24).

**4.4.4.3 Loading.** Without shock, apply and increase the compressive force continuously at a nominal rate within the range  $0.02 \text{ N}/(\text{mm}^2 \text{ s})$  to  $0.04 \text{ N}/(\text{mm}^2 \text{ s})$ . Maintain the rate, once adjusted, until failure. On manually controlled machines as failure is approached the loading rate will decrease; at this stage operate the controls to maintain as far as is possible the specified loading rate. Record the maximum force applied to the specimen. The rate of increase of load (in N/s) may be calculated from the formula:

$$(0.02 \text{ to } 0.04) 1.571/d$$

#### 4.4.5 Calculations and expression of results

**4.4.5.1** Calculate the tensile splitting strength ( $\sigma$ , in Pa) from the formula:

$$\sigma = 2F/\pi/d$$

where

- $F$  is the maximum load (in N);
- $l$  is the length of specimen as shown in Figure 24 (in mm);
- $d$  is the cross-sectional dimension of the specimen as shown on Figure 24 (in mm).

**4.4.5.2** Express the tensile splitting strength to the nearest 0.05 Pa.

#### 4.4.6 Test report

The test report shall affirm that the tensile splitting strength was determined in accordance with 4.4 of BS 1924-2:1990 and whether or not a certificate of sampling is available. If available a copy of the certificate of sampling shall be provided. The report shall contain the following additional information:

- a) sample identification;
- b) the mean tensile splitting strength of the set of specimens together with the results for the individual specimens;
- c) the moisture content and dry density at which the specimens were prepared and/or the moisture content and dry density at which they were tested;
- d) the age at which the specimens were tested;
- e) conditions of curing and storage.

### 4.5 Laboratory determination of the California Bearing Ratio

**NOTE** This test was included in previous editions of the standard under the title of Bearing Ratio. As this has caused some confusion and as the test method is virtually identical to the California Bearing Ratio (CBR) test described in BS 1377-4, it is now included in this edition under the latter name.

#### 4.5.1 Principle

The California Bearing Ratio (CBR) of a compacted specimen of stabilized material is obtained by measuring the forces required to cause a cylindrical plunger of a specified size to penetrate the specimen at a specified rate. From the test results an arbitrary coefficient, the CBR, is calculated. This is done by expressing the forces on the plunger for a given penetration as a percentage of a standard force. Because of the restriction of the diameter of the mould and of the plunger, the test is only appropriate to that part of the material up to a maximum particle size of 20 mm (see note to 4.5.4.1).

The requirements of BS 1924-1 shall where appropriate apply to this test method.

#### 4.5.2 Apparatus

**4.5.2.1** A balance, of 25 kg minimum capacity, readable to 5 g.

**4.5.2.2** 5 mm and 20 mm test sieves.

**4.5.2.3** A steel rod, 15 mm to 20 mm in diameter and approximately 400 mm long.

**4.5.2.4** Apparatus for the determination of moisture content by the oven-drying method described in 1.3.3.

**4.5.2.5** A cylindrical metal mould (CBR mould), having an internal diameter of  $152 \pm 0.5$  mm and an internal effective height of  $127 \pm 1$  mm, with detachable baseplate and top plate and an extension collar for attachment to the top of the mould during compaction of a specimen. An alternative perforated baseplate shall be used for soaked specimens. Internal faces shall be clean and dry before use.

NOTE A typical mould and collar is shown in Figure 25.

**4.5.2.6** Three metal plugs,  $150 \pm 0.5$  mm in diameter and  $50 \pm 1.0$  mm thick, for static compaction of a specimen.

NOTE A handle which may be screwed into the plugs facilitates removal after compaction. A suitable form of plug and handle is shown in Figure 26.

**4.5.2.7** A cylindrical metal plunger, the flat lower end of which shall be of hardened steel with a nominal circular area of  $1\,935 \text{ mm}^2$  corresponding to a specified diameter of  $49.65 \pm 0.1$  mm.

NOTE A convenient size is approximately 250 mm long (see Figure 27).

**4.5.2.8** A machine for producing a steady penetration of the plunger into the material under test and measuring the reaction to penetration. The machine shall be capable of producing a rate of penetration of the plunger of 1 mm/min to within  $\pm 0.2$  mm/min. The load measuring system shall comply with grade 2.0 of BS 1610. At least two force ranges shall be provided, i.e. 0.5 kN to 10 kN and 2.5 kN to 50 kN.

NOTE If hydraulic jacking is used to produce penetration the pump should be multi-pistoned to produce steady motion. Single piston, hand-operated pumps should not be used as the resultant motion is a series of pulses.

**4.5.2.9** A means of measuring the penetration of the plunger into the specimen to within 0.01 mm.

NOTE A dial gauge with 25 mm travel, reading to 0.01 mm and fitted to a bracket attached to the plunger is suitable. A general arrangement is shown in Figure 27.

A dial gauge indicating 1 mm/rev is convenient since the specified rate of penetration of 1 mm/min can be maintained by keeping the hand of the dial gauge in step with the second hand of a watch.

**4.5.2.10** A metal rammer, either the 2.5 kg rammer as specified in 2.1.3.2.3 or the 4.5 kg rammer as specified in 2.1.4.3.1 depending on the degree of compaction required.

NOTE A mechanical compacting apparatus may be used provided it complies with the requirements of 2.1.3.2.3 or 2.1.4.3.1.

**4.5.2.11** An electric vibrating hammer, as specified in 2.1.6.3.2.

**4.5.2.12** A compression machine for static compaction, of 300 kN maximum force, with horizontal platens not less than 200 mm square and capable of separation of not less than 300 mm.

**4.5.2.13** A stopwatch or stopclock, readable to 1 s.

**4.5.2.14** A steel straightedge, e.g. 300 mm  $\times$  25 mm  $\times$  3 mm thick with one bevelled edge.

**4.5.2.15** A palette knife, having a steel blade approximately 100 mm  $\times$  20 mm.

**4.5.2.16** A means of measuring the vertical movement of the top of the specimens during soaking (see Figure 28).

**4.5.2.17** Filter papers<sup>6)</sup>, 150 mm in diameter.

#### 4.5.3 Materials

**4.5.3.1** Paraffin wax, or other suitable wax, or petroleum jelly.

**4.5.3.2** Dry fine sand.

#### 4.5.4 Preparation of test specimens

**4.5.4.1** General. Carry out the test on material passing the 20 mm test sieve (see note). Choose the moisture content and the stabilizer content and the state of compaction to reproduce as closely as possible the conditions likely to apply in the pavement. Use one of the alternative methods for compacting the specimens specified in 4.5.4.2 or 4.5.4.3.

NOTE If the test is to be made on samples containing particles larger than 20 mm, the fraction retained on the 20 mm sieve should be removed and replaced with a similar fraction of 20 mm to 5 mm material from the main sample. If the amount retained on the 20 mm sieve exceeds 25 % the material is too coarse to be tested. The samples may be compacted statically (4.5.4.2) or dynamically (4.5.4.3).

##### 4.5.4.2 Static compaction

**4.5.4.2.1** General. Static compaction shall be either by method 1 or by method 2.

Calculate the mass ( $m_1$ , in g) of stabilized material required for one specimen from the equation:

$$m_1 = 23.05\rho_d(100 + w)$$

where

$w$  is the moisture content of the stabilized material (in %);

$\rho_d$  is the dry density of the stabilized material (in  $\text{Mg/m}^3$ ).

<sup>6)</sup> Whatman No. 1 filter papers are suitable.

**4.5.4.2.2 Method 1.** Assemble the mould with its collar and baseplate, the latter covered by filter paper. Pour the weighed material slowly into the mould, whilst tamping continuously with the steel rod. The amount of tamping shall be such that when all the material has been added, the level is about 5 mm to 10 mm above the top of the mould. After tamping place a filter paper on the top of the soil followed by a 50 mm thick plug and compress the specimen in the compression testing machine until the top of the plug is flush with the top of the collar. Hold the force constant for at least 30 s and then release.

NOTE After compaction remove the plug and filter paper together with the collar, and cure the specimen as described in 4.5.5.

**4.5.4.2.3 Method 2.** Assemble the mould as in method 1. Divide the required quantity of material into three equal parts each sealed in a container to prevent loss of moisture. Pour one-third of the stabilized material into the mould. Then fit three plugs, with their handles removed, and compress the material using the compression machine until the thickness of the material, after removal of the force, is one-third of the depth of the mould.

Add the second and third layers in a similar manner to the first. In the last operation use one plug only and push it until the top surface is level with the top of the collar. Cure the specimen as described in 4.5.5.

#### 4.5.4.3 Dynamic compaction

**4.5.4.3.1 General.** Three procedures using dynamic compaction are in use. The first two are used where a required density is to be obtained by a process of dynamic or vibrational compaction (as an alternative to the static compaction methods given in 4.5.4.2 where a compression machine is not available). The third is used where a given amount of compactive effort is to be applied to the stabilized material as in the compaction tests described in section 2. Carry out dynamic compaction by one of the methods described in 4.5.4.3.2 to 4.5.4.3.4.

**4.5.4.3.2 Method 1.** Assemble the mould with its baseplate, weigh to the nearest 5 g and record the mass ( $m_2$ ). Fit the collar and place a filter paper in the bottom. Calculate and prepare the mass of stabilized material necessary to give the required density as for the static compaction procedure in 4.5.4.2. Divide this quantity into five equal parts by mass, each sealed in a container to prevent loss of moisture by evaporation. Then compact the stabilized material into the mould with the collar attached, in five equal layers using either the 2.5 kg rammer or the 4.5 kg rammer. Give each layer sufficient blows distributed evenly over the surface to ensure that the layer after compaction occupies approximately one-fifth of the height of the mould. When compacted in this manner the final level of the stabilized material shall be just above the mould. Remove the collar and trim the material flush with the top of the mould using a palette knife and check with a steel straightedge. Determine the mass ( $m_3$ ) of the mould with the baseplate attached and containing the specimen to the nearest 5 g.

NOTE Preliminary tests may be required in which adjustments have to be made to the number of blows needed to fill the mould to the top with the calculated mass of material.

Cure the compacted specimen as described in 4.5.5.

**4.5.4.3.3 Method 2.** Prepare the mould and the stabilized material as described in method 2 under static compaction (4.5.4.2.3). Pour one-third of the material into the mould and compact with a vibrating hammer as specified in the vibrating hammer compaction test (2.1.6). Continue vibrational compaction until the thickness of the layer is equal to one-third of the depth of the mould. Add the second and third layers and compact in the same manner so that the final surface of the stabilized material is level with the top of the mould. Weigh the mould with baseplate and record its mass ( $m_3$ ). Cure the specimen as described in 4.5.5.

**4.5.4.3.4 Method 3.** Prepare and weigh the mould with its baseplate as in method 1. Fit the collar and place a filter paper in the bottom. Prepare approximately 6 kg of the stabilized material at the required moisture content. Use either of two levels of compaction; the first employs the 2.5 kg rammer and the second the 4.5 kg rammer. If the 2.5 kg rammer is used, place enough material in the mould, with the collar attached, so that after 62 blows of the rammer spread uniformly over the surface of the material under test, the surface level is one-third of the distance up the mould or slightly above this level. Using in each case the same mass of stabilized material, add two further layers and compact in the same manner so that the final level is less than 6 mm above the top of the mould.



NOTE 1 Preliminary trials may be necessary to judge the amount of material required for each layer.

Remove the collar and trim any excess material flush with the top of the mould using a palette knife and check with the steel straightedge. Weigh and record the combined mass ( $m_3$ ) of the mould, baseplate and compacted material to the nearest 5 g. For the higher level of compaction use the same procedure except that 62 blows of the 4.5 kg rammer shall be employed and the stabilized material placed and compacted in five equal layers (see note 2). Cure the specimen as described in 4.5.5.

NOTE 2 In certain circumstances an intermediate density may be required between that given by the 2.5 kg rammer and the 4.5 kg rammer used in the manner specified. This can be obtained for example by using an intermediate compactive effort, such as compacting the specimen in five equal layers and giving each layer 30 blows of a 4.5 kg rammer falling through 450 mm.

#### 4.5.5 Curing

After compaction store the specimen for a period, the length of which will depend upon the process and the type of stabilizer employed. Normally, the specimen is kept at constant moisture content during this period; this may be achieved by coating the ends of the specimen with wax, or placing the end caps on the mould and sealing them with petroleum jelly. Keep the specimens at  $20 \pm 2$  °C (see note 2) and record the average temperature and duration of storage. If it is required to soak the specimen, expose the two ends and attach a perforated baseplate separated from the specimen by a filter paper. Screw a collar to the top and seal the joint with petroleum jelly. Place the specimen in a bath of water and keep the water level just below the top of the collar. Observe the time taken for the water to reach the top of the specimen and, if this has not occurred within 3 days, flood the top of the specimen and leave it to complete its normal soaking period. The normal soaking period is 7 days (see note 1) and the bath shall be kept at a temperature of  $20 \pm 2$  °C (see note 1). If during soaking, measurement of any swell that has occurred is required, place a filter paper and perforated plate on top of the specimen and suitably mount a dial gauge, reading to 0.01 mm (see Figure 28), to follow any movement of the surface. When soaking is completed remove the specimen from the bath and allow to drain for 15 min. Replace the baseplate, remove the collar and perforated plates, weigh to the nearest 5 g and record the mass of the assembly ( $m_4$ ).

NOTE 1 The curing temperature of  $20 \pm 2$  °C applies in temperate climates. For areas with a tropical or subtropical climate, a curing temperature of  $27 \pm 2$  °C is more appropriate.

NOTE 2 A procedure commonly followed in tropical and subtropical countries with cement-stabilized material is to cure the specimen after manufacture for 3 days followed by soaking for 4 days.

#### 4.5.6 Test procedure

4.5.6.1 Before testing remove the end-caps or the protective wax and filter paper sealing the specimen. If the specimen has been soaked, remove the perforated top plate and filter paper. Place the mould, containing the specimen, with baseplate in position but with the top face exposed, on the lower platen of the testing machine. Seat the plunger under a force of 50 N for a CBR value of up to 30 % or 250 N for a CBR value of 30 % to 300 %. Allow the plunger to penetrate the specimen at a uniform rate of 1 mm/min. Take readings of the force at intervals of penetration of 0.25 mm to a total penetration not exceeding 7.5 mm.

4.5.6.2 Raise the plunger and remove any material projecting over the top of the mould. Fill any depressions left by the plunger completely with dry fine sand and trim up the face of the specimen by a further pass of a palette knife and check with the straightedge. Then secure the second baseplate to the upper end of the mould.

4.5.6.3 Invert the specimen and remove the baseplate from the untested end of the mould. Repeat the procedure described in 4.5.6.1 on this end of the specimen.

4.5.6.4 After the penetration tests have been completed remove the specimen from the mould. Break it up and take a representative sample of the stabilized material for the determination of its moisture content by the method described in 1.3.3. Do not include the dry sand, used in the end first tested, in the moisture content sample.

#### 4.5.7 Calculations and expression of results

NOTE A typical data and calculation form for the determination of the CBR value is given in form N of Appendix A.

4.5.7.1 *Force/penetration curve*. Plot a graph showing force on the specimen against penetration and draw a smooth curve through the plotted points. If the initial portion of the curve is concave upwards (which may be due to surface irregularities) a correction should be made by drawing a tangent to the curve at the point of the greatest slope. Take the intersection of this tangent and the penetration axis as the new origin. The corrected force/penetration curve to be used in the calculations is this tangent from where it cuts the penetration abscissa to its point of contact with the curve and thence the curve itself. To use this corrected curve either:

- a) transpose the co-ordinates to the right so that the tangent passes through their origin; or
- b) transpose the corrected curve to the left so that the new and original origin coincides as shown in Figure 29.

NOTE The CBR test should not be taken beyond a penetration of 7.5 mm. If penetrations greater than 7.5 mm would be required to obtain a corrected value for 5 mm penetration, then the correction should be made from 7.5 mm. When both ends of the specimen are tested it is preferable to use the minimum penetration which will give an accurate CBR value. If the operator plots the force penetration curve as the test is being carried out the test can be terminated when the indicated CBR falls below its maximum value. Thus if the CBR at 2.5 mm was seen to be 6 % but by 3.5 mm penetration it was seen to have fallen below this value the test could be stopped and the result reported as follows:

- 2.5 mm penetration 6 %;
- 5.0 mm penetration < 6 %.

**4.5.7.2 Calculation of CBR.** CBR curves are given in the force/penetration diagram shown in Figure 29. The standard forces for 100 % CBR are as given in Table 2.

**Table 2 — Standard forces for 100 % CBR**

Force	Penetration
kN	mm
11.5	2
17.6	4
22.2	6
26.3	8
30.3	10
33.5	12

Calculate CBR at penetrations of 2.5 mm and 5 mm and take the higher value.

**4.5.7.3 Calculation of dry density (unsoaked specimens)**

**4.5.7.3.1** Calculate the bulk density ( $\rho$ , in Mg/m<sup>3</sup>) of the specimens compacted by static or vibratory compaction from the equation:

$$\rho = m_1/2305$$

where

$m_1$  is the mass of material compacted in the mould (in g).

**4.5.7.3.2** Calculate the bulk density ( $\rho$ , in Mg/m<sup>3</sup>) of dynamically compacted specimens from the equation:

$$\rho = (m_3 - m_2)/2305$$

where

$m_2$  is the mass of the mould (in g);

$m_3$  is the mass of compacted material and mould (in g).

**4.5.7.3.3** Calculate the dry density ( $\rho_d$ , in Mg/m<sup>3</sup>) of the specimens from the equation:

$$\rho_d = 100\rho/(100 + w)$$

where

$w$  is the moisture content of the stabilized material (in %).

**4.5.7.4 Calculation of the original dry density (soaked specimens).** Calculate the original dry density ( $\rho_d$ ) of the specimens from the equation:

$$\rho_d = 0.0434 (m_4 - m_2)/(100 + w_1)$$

where

$m_4$  is the mass of specimen plus mould after soaking (in g);

$w_1$  is the moisture content of the specimen after soaking (in %).

**4.5.7.5 Reporting CBR values.** Report CBR values in accordance with Table 3.

**Table 3 — CBR values**

CBR range	Nearest %
0 – 9	0.5
10 – 29	1
30 – 99	5
100 – 300	10
300 +	report as > 300

NOTE Normally the results from the top and the bottom should be reported separately.

**4.5.8 Test report**

The test report shall affirm that the California Bearing Ratio was determined in accordance with 4.5 of BS 1924-2:1990 and whether or not a certificate of sampling is available. If available a copy of the certificate of sampling shall be provided. The report shall contain the following additional information:

- a) sample identification;
- b) the CBR values obtained on the top and bottom of the specimens;
- c) the method of compaction;
- d) the moisture content and dry density at which the specimens were prepared and/or the moisture content and dry density at which they were tested;
- e) the age at which the specimens were tested and, where applicable, the period of soaking;
- f) conditions of curing and storage;
- g) the amount of swell during soaking (if measured).

## 4.6 Determination of the in-situ California Bearing ratio

Since the method for measuring the in-situ CBR of a stabilized layer of material is the same as the method for testing soils in-situ, follow the method described in BS 1377-9.

## 4.7 Determination of the vertical deformation characteristics by the plate loading test

Since the method for measuring the plate bearing value of a stabilized layer of material is the same as the method for testing soils in-situ, follow the method described in BS 1377-7.

## 4.8 Determination of the frost-heave

### 4.8.1 General

The description of the frost-heave test is lengthy and has not been included in this Part of BS 1924 because the test is described fully in BS 812-124. This section therefore contains only the information that is necessary to prepare specimens of stabilized material so that they can be tested by the procedure given in BS 812-124.

**NOTE** Stabilized materials with high compressive strengths (in excess of  $2.5 \text{ MN/m}^2$  at the time of test) will almost invariably have frost-heave values that are well within acceptable limits. It is therefore not necessary to use the test on such materials. However, relatively small proportions of cement are sometimes used to reduce frost-heave rather than to impart high strength and a test is therefore required to determine the effect of the addition of the stabilizer on the frost-heave of the stabilized material. The test is also required in the case of lime-stabilized cohesive materials when lime has been added to decrease the plasticity, as the decrease of plasticity may be accompanied by an increase in susceptibility to frost.

### 4.8.2 Sampling

**4.8.2.1** The sample received at the laboratory shall be taken in accordance with 5.3 of BS 1924-1:1990.

**4.8.2.2** Reduce the laboratory sample by the procedures described in 5.4 of BS 1924-1:1990 to produce the following test portions:

- a) at least 12 test portions each with approximate mass of 2.5 kg, for carrying out a determination of the moisture content/density relation by the method given in 2.1.5 or 2.1.6 (see note to 4.8.3);
- b) one test portion with a minimum mass of 50 kg, for the main frost-heave test procedure.

### 4.8.3 Selection of moisture content and density

Determine the relation between the dry density and moisture content of the stabilized material by the procedure given in 2.1.5 (or by the alternative procedure given in 2.1.6) (see note). Use the values of maximum dry density and optimum moisture content obtained for this test as the values to be used in the first instance for the preparation of the frost-heave test specimens.

**NOTE** For fine-grained cohesive materials the compaction test procedure given in 2.1.3 shall be used to determine the moisture content and density at which to prepare the frost-heave test specimens.

### 4.8.4 Preparation of frost-heave test specimens

**4.8.4.1** Subdivide the test portion obtained as described in 4.8.2.2 b) by riffing until a representative test sample of mass about 15 kg is obtained. Set aside the remainder of the test portion in case it is needed for repeat tests and use the 15 kg test sample to prepare a set of three specimens as described in clause 9 of BS 812-124:1989. In preparing the mixes follow the procedure given in 6.3 of BS 1924-1:1990 for the addition of water and stabilizer.

**4.8.4.2** After extruding the test specimens as described in 9.3.2 of BS 812-124 do not follow the procedure described in 9.3.3 of BS 812-124 but allow the specimen to cure as described in 4.8.5.

### 4.8.5 Curing the test specimen

**NOTE** Specimens may be cured either by the method given in 4.8.5.1 and 4.8.5.2 or by that given in 4.8.5.3.

**4.8.5.1** After the specimens have been removed from the moulds allow them to cure for a sufficient time for strength to develop (see note 1). During the curing period it is essential that the specimens do not lose any water. Follow the procedure given in 9.3.2 of BS 812-124:1989 for the extrusion of the specimens from the moulds (see notes 2 and 3). Then follow the procedure for completion given in 9.3.3 of BS 812-124:1989 but do not load the specimen assemblies into the self-refrigerated unit (SRU) unless the SRU will be available for the duration of the test.

**4.8.5.2** Place the specimen assemblies in a sealed container or containers so that the porous discs at the bottom of the specimens are in contact with water and store the specimens in the container at a constant temperature of  $20 \pm 2 \text{ }^\circ\text{C}$  until required for test. During the curing period examine the containers periodically and add further water, if necessary, to ensure that the porous discs remain in contact with water.

**NOTE 1** In the case of frost-heave tests on stabilized materials the stabilizer should be allowed to take effect before the test is carried out. In practice several months, if not years, will usually elapse between the addition of the stabilizer and any exposure to freezing conditions. Laboratory tests will therefore tend to give a pessimistic impression of the frost susceptibility of stabilized materials because the curing period will be so much less than that likely to occur in practice. As a compromise between speed of testing and allowing the stabilizer to take full effect it is suggested that cement-stabilized specimens should be allowed to cure for a minimum of 7 days and lime-stabilized specimens for a minimum of 28 days.

**NOTE 2** In the case of non-cohesive materials it may be advantageous to allow specimens to harden in their moulds for 24 h before attempting to extrude them.

**4.8.5.3** Coat the specimens completely with paraffin wax to maintain them at their specified moisture content. Take care not to leave holes in the wax film and to complete the coating as quickly as possible to prevent absorption of the wax. After coating with wax, weigh each specimen, record its mass ( $m_1$ ) and store at a constant temperature of  $20 \pm 2$  °C. To simplify the removal from a specimen the wax should be used as cool as possible. If it is not possible to coat the specimens with wax wrap each one carefully in thin plastics sheeting and transfer them to sealed airtight plastics bags (or other suitable containers) of a size just sufficient to hold an individual specimen. In the case of stabilized specimens prepared from washed and graded aggregates free from fines it is acceptable to cure them by allowing them to harden in their moulds for 24 h and then to store them totally immersed in water at  $20 \pm 2$  °C until required.

At the end of the curing period weigh each specimen and record its mass ( $m_2$ ). Reject any specimen that has lost more than 15 g in mass. Carefully remove the wax (or plastics sheeting) from the specimens taking particular care that all traces of wax are removed from the ends of the test specimens. Then follow the procedure described in **9.3.3** of BS 812-124:1989.

#### **4.8.6 Procedure for the determination of frost-heave**

After curing carry out the frost-heave test in accordance with clauses **10** and **11** of BS 812-124:1989.

#### **4.8.7 Test report**

Report all the information required in clause **13** of BS 812-124:1989 together with the following additional information:

- a) the stabilizing agent used;
- b) the stabilizer content;
- c) conditions of curing and storage;
- d) age at which the specimens were tested.

## Section 5. Chemical tests

### 5.1 Determination of the cement content of cement-stabilized materials

NOTE The analytical procedure of this test is the same in principle to the procedure described in previous editions of BS 1924 but it has been modified to bring the method into line with the analogous method given for the determination of the cement content of hardened concrete given in BS 1881-124. The method is not applicable to materials containing a large or variable amount of calcium or to materials stabilized with both lime and cement.

#### 5.1.1 Principle

The cement content of the stabilized material is obtained by comparing the calcium contents of the stabilized material, the material in an unstabilized condition and the cement used. It is therefore essential that samples of each of these should be available.

NOTE Certain assumptions can be made about the calcium content of cement and this allows an approximate cement content to be calculated even when no sample of the cement is available (see note to 5.1.7.2).

The requirements of BS 1924-1 shall where appropriate apply to this test method.

#### 5.1.2 Apparatus

NOTE The apparatus given is sufficient to enable two test portions each of the natural material, the stabilized material and the cement to be analysed. Where several analyses are to be made it is convenient to have one beaker, one flask, etc., for each determination. Items such as sieves and riffles need not be multiplied.

**5.1.2.1** A *temperature-controlled oven*, capable of maintaining a temperature of  $105 \pm 5$  °C.

**5.1.2.2** A *temperature-controlled oven*, capable of maintaining a temperature in the range 150 °C to 200 °C.

**5.1.2.4** A *balance*, of 100 g minimum capacity, readable to 1 g.

**5.1.2.4** A *balance*, of 100 g minimum capacity, readable to 0.0001 g.

**5.1.2.5** A *desiccator*, containing anhydrous silica gel.

**5.1.2.6** *Test sieves*, with receivers as follows: 14 mm, 6.3 mm, 2 mm and 425 µm.

**5.1.2.7** *Twelve 500 mL and four 250 mL volumetric flasks*, complying with grade B of BS 1792.

**5.1.2.8** *Graduated measuring cylinders*, grade B to BS 1797, as follows: one 10 mL, one 25 mL, one 100 mL and one 1 000 mL.

**5.1.2.9** *Six glass weighing bottles*, approximately 50 mm high and 25 mm in diameter, fitted with ground-glass stoppers.

**5.1.2.10** *Crushing and grinding equipment*.

NOTE Jaw crushers, hammer mills, disc grinders, gyratory mills and mechanical or hand-operated mortars and pestles are among the types that have proved to be satisfactory.

**5.1.2.11** A *wash bottle*, containing distilled water or water of equivalent quality to that specified in 4.3.1 of BS 1924-1:1990.

**5.1.2.12** *Six glass funnels*, approximately 75 mm in diameter.

**5.1.2.13** *Hardened filter papers*<sup>7)</sup>, to fit the funnels.

**5.1.2.14** *One 50 mL and two 25 mL burettes*, complying with grade B of BS 1797.

**5.1.2.15** *One 25 mL and two 50 mL pipettes*, complying with grade B of BS 1797.

**5.1.2.16** *Six 250 mL conical flasks*.

**5.1.2.17** *Beakers*, as follows: two 250 mL beakers and four 400 mL beakers (preferably conical), two 500 mL beakers and one 1 000 mL beaker, with an equal number of glass rods and cover glasses.

**5.1.2.18** *An electric hot-plate or bunsen burner*.

**5.1.2.19** *A fume cupboard*.

#### 5.1.3 Sampling

**5.1.3.1** The bulk samples of the stabilized and unstabilized materials shall be taken in accordance with the procedure described in clause 5 of BS 1924-1:1990. The sample of cement shall be taken from the particular batch being used for the work.

NOTE The calcium content of the cement is far higher and less variable than the calcium contents of the other components. In addition slight variations in the calcium content of the cement have only a small effect on the calculated result. A 1 kg sample of the cement will therefore be sufficient.

**5.1.3.2** Dry the bulk samples of the natural and stabilized materials in the oven at  $105 \pm 5$  °C and allow to cool. To facilitate sample reduction break down the larger lumps and, if necessary, reduce by the procedures described in 5.4 of BS 1924-1:1990 to produce a mass of material that when crushed and sieved will produce a laboratory sample of the mass given in 5.1.3.3.

**5.1.3.3** Crush (see note) and sieve suitable masses of the natural and stabilized materials to produce the following laboratory samples of each:

- a) for fine-grained materials: 250 g all passing a 2.0 mm test sieve;
- b) for medium-grained materials: 2.5 kg all passing a 6.3 mm test sieve;
- c) for coarse-grained materials: 6 kg all passing a 14 mm test sieve.

Throughout these and all subsequent operations ensure that there is no loss of fines of any material.

<sup>7)</sup> Whatman No. 54 filter papers are suitable.

**NOTE** The pulverization of fine-grained materials should not present any problems and may usually be done by hand with a pestle and mortar. The grinding of the coarser materials by hand is tedious and is difficult with a pestle and mortar without losing some of the material. For this reason mechanical pulverizers are recommended but where the number of samples to be crushed is small, the cost of mechanical crushers would not be justified and crushing by hand in an iron mortar would have to be adopted. Any mechanical means may be employed and two-stage crushing is generally the most satisfactory.

#### 5.1.4 Reagents

**NOTE** Unless otherwise stated, all reagents should be of recognized analytical quality and distilled or water of equivalent quality should be used throughout the analyses. Dilutions of acids and other liquid reagents are given as (1 + *n*) which indicates that one volume of the concentrated reagent is added to *n* volumes of water and mixed. Filter solutions of solid reagents if the solution is not clear. Reagents should either be prepared by the methods given in this subclause or should be proprietary reagents of equivalent equality.

**5.1.4.1 Calcein (screened) indicator.** Mix by grinding together 0.2 g of calcein, 0.12 g of thymolphthalein and 20 g of potassium chloride.

**5.1.4.2 Calcium standard solution** (approximately 1.00 g CaO/L). Weigh 1.78 g to 1.79 g of pure calcium carbonate (dried at a temperature in the range 150 °C to 200 °C) and record the mass to the nearest 0.0001 g. Dissolve in a slight excess of hydrochloric acid (1 + 4), boil to expel carbon dioxide, cool and dilute to 1 L in a volumetric flask.

Calculate the concentration of CaO in g/L to three significant figures from the equation:

$$\text{Concentration of CaO} = \text{mass of CaCO}_3 / 1.7848$$

**5.1.4.3 EDTA standard solution.** Dissolve 6.67 g of EDTA (ethylenediaminetetra-acetic acid, disodium salt) in warm water, filter if necessary, cool and dilute to 1 L. Store in a polyethylene bottle. Standardize against the standard calcium solution as follows.

Pipette 25 mL of the standard calcium solution into a 500 mL flask, add 10 mL of triethanolamine solution (1 + 4) and 10 mL of sodium hydroxide solution (200 g/L) and dilute to about 150 mL. Add about 0.15 g of calcein indicator and titrate with the EDTA solution until the fluorescent green of the indicator completes the change to pink-purple with no residual fluorescence. The end-point is more easily seen if observed against a black background. Calculate the CaO equivalent (*E*) of the EDTA (in mg CaCO<sub>3</sub>/mL) from the equation:

$$E = 25ht$$

where

*h* is the concentration of CaO in the standard calcium solution (in g/L);

*t* is the volume of EDTA required in the titration to the nearest 0.05 mL (in mL).

**5.1.4.4 Hydrochloric acid**, concentrated, relative density 1.18.

**5.1.4.5 Hydrochloric acid**, dilute (1 + 1), (1 + 4) and (1 + 9).

**5.1.4.6 Sodium hydroxide solution** (200 g/L).

**5.1.4.7 Triethanolamine solution** (1 + 4).

**5.1.4.8 Ammonia solution** (1 + 4). Dilute 100 mL of ammonia solution (relative density 0.880) to 500 mL with distilled water.

**5.1.4.9 Red litmus papers.**

#### 5.1.5 Preparation of test portions

**5.1.5.1** Dry the laboratory sample of the natural and stabilized materials, obtained as described in **5.1.3** in the oven at 105 ± 5 °C for not less than 16 h and cool, preferably in a desiccator. Pulverize the oven-dried samples using mechanical pulverizers or other suitable means (see note to **5.1.3.3**) so that the whole of the sample passes a 425 µm test sieve. Subdivide each sample by riffing on a sample divider having a width of opening of approximately 7 mm until two test portions of each sample each weighing approximately 10 g are obtained. In the case of the medium- and coarse-grained materials, riffing may be done more conveniently on larger sample dividers, but when the size of the sample has been reduced to 250 g use a sample divider having a width of opening of about 7 mm. Place the test portions in the glass weighing bottles and dry at 105 °C ± 50 °C.

**NOTE** The period required for drying may vary with the type of material. The test portions can be deemed to be dry when the differences in successive weighings of the cooled sample, carried out at intervals of 4 h, do not exceed 0.1 % of the original mass of the sample. For practical purposes 16 h to 24 h is usually sufficient.

**5.1.5.2** From the bulk sample of cement obtained as described in **5.1.3.1** produce by appropriate sample reduction techniques, two test portions each weighing about 1 g. Place the test portions in the glass weighing bottles and dry at 105 °C to 110 °C.

**NOTE** The test portions can be deemed to be dry when the differences in successive weighings of the cooled sample, carried out at intervals of 4 h, do not exceed 0.1 % of the original mass of the sample. For practical purposes 16 h to 24 h is usually sufficient.

#### 5.1.6 Analytical procedures

**NOTE** The procedure given below should be carried out on each of the test portions of the natural and stabilized materials respectively and of the cement.

**5.1.6.1 Preparation of the acid extracts of the natural and stabilized material**

**5.1.6.1.1** Remove the weighing bottle containing the test portion from the oven, cool in the desiccator and weigh to the nearest 0.001 g. Transfer the test portion to a 400 mL conical beaker, reweigh the weighing bottle and calculate the mass (*m*) of the test portion by difference.

**5.1.6.1.2** Add 100 mL of (1 + 1) hydrochloric acid to the beaker, cover it with a cover glass and bring the contents to the boil. After boiling for 1 min remove the beaker from the heat source and allow to cool for 10 min. Quantitatively transfer the contents of the beaker through a glass funnel to a 500 mL volumetric flask, care being taken that no solid material remains in the beaker, and adjust the volume to 500 mL with distilled water. Shake the flask and allow the suspension to settle for a few minutes. Remove a 50 mL aliquot portion with a pipette and transfer to a 250 mL volumetric flask, if it is to be analysed according to procedure A described in **5.1.6.3.1**, or to a 250 mL beaker if it is to be analysed according to procedure B described in **5.1.6.3.2**.

**5.1.6.2** *Preparation of the acid extract of the cement.* Follow the procedure given in **5.1.6.1** except in **5.1.6.1.2** use 10 mL of (1 + 1) hydrochloric acid and 25 mL of distilled water for the digestion and retain a 25 mL aliquot portion of the 250 mL solution for subsequent analysis by procedure A described in **5.1.6.3.1**.

#### **5.1.6.3** *Analysis of the acid extracts*

NOTE Two procedures are given for the analysis of the acid extracts. Procedure A is to be followed in those cases where co-precipitation of calcium when the sesquioxides are removed is unlikely to affect the results, and procedure B is the alternative procedure that has to be followed if the effects of co-precipitation are serious. In general, the effect of co-precipitation should be allowed for in cases where a material containing no calcium and a high proportion of iron and aluminium has been stabilized with a low proportion of cement. Such a combination is likely to arise, for example, with tropical soils such as laterites rich in iron and aluminium.

##### **5.1.6.3.1** *Procedure A*

(For natural material and stabilized material where the effects of co-precipitation can be ignored and for the cement sample.)

Drop a small piece of litmus paper into each volumetric flask and add (1 + 4) ammonia solution (preferably from a burette) until the litmus changes from red to blue. After the addition of the ammonia solution adjust the volume of the suspension to exactly 250 mL with distilled water and thoroughly mix the contents of the flask by shaking. Set the flask aside until the precipitate has settled to the bottom; when it has settled remove 50 mL of the clear supernatant liquid by means of a pipette and place in a 250 mL conical flask or beaker. Dilute to about 150 mL, add 10 mL of the triethanolamine solution, 10 mL of the sodium hydroxide solution and about 0.15 g screened calcein indicator. Titrate with standard EDTA solution, using magnetic stirring if possible, until the fluorescent green of the indicator completes the change to pink-purple with no residual fluorescence (see **5.1.4.3**). Record the volume (*V*) of the EDTA used in the titration to the nearest 0.02 mL.

##### **5.1.6.3.2** *Procedure B*

(For natural material and stabilized material extracts when co-precipitation of calcium is a problem.)

Place the aliquot portions obtained from the digestions of the natural and stabilized materials in 250 mL beakers. Bring the contents of each beaker to the boil and add (1 + 4) ammonia solution very slowly (preferably from a burette) with constant stirring until the solution is alkaline to litmus. Allow the mixture to cool and filter into a 250 mL volumetric flask through a hardened filter paper<sup>8)</sup>. When the beaker has been drained and filtration has ceased carefully remove the filter paper and contents from the funnel and transfer back to the beaker. Add 25 mL of (1 + 9) hydrochloric acid to the beaker and stir the mixture until all the sesquioxides have dissolved; if more acid is required according to the sesquioxide content, keep the acid used to a minimum. Remove the filter paper and wash with water until all traces of yellow coloration have disappeared. Collect these washings in the beaker and, when washing is completed, reject the filter paper and bring the contents of the beaker to the boil.

NOTE In order to keep the final volume below 250 mL the contents of the beaker may, if necessary, be reduced in volume by boiling at this stage.

<sup>8)</sup> Whatman No. 541 filter papers are suitable.

Add (1 + 4) ammonia solution as before to re-precipitate the sesquioxides and filter the contents of the beaker through a filter paper<sup>9)</sup> into the same volumetric flask. Shake the flask thoroughly and make the filtrate up to 250 mL. Shake the flask thoroughly and remove 50 mL of the solution. Set the flask aside. When the precipitate has settled to the bottom analyse as in procedure A.

### 5.1.7 Calculations and expression of results

NOTE A typical data and calculation form for the determination of the cement content of cement-stabilized materials is given in form O of Appendix A.

#### 5.1.7.1 Unhydrated stabilized materials

5.1.7.1.1 For each test portion calculate to the nearest 0.1 % the calcium contents (as CaO) of the unstabilized material ( $X$ ), the stabilized material ( $Y_1$ ) and the cement ( $Z$ ) from the appropriate equation as follows:

$$X, Y_1 \text{ or } Z = 5 VE/m$$

where

- $V$  is the volume of EDTA required in titration (in mL);
- $E$  is the calcium oxide equivalent of the EDTA solution (in mg CaO/mL) (see 5.1.4.3);
- $m$  is the mass of the test portion (in g).

5.1.7.1.2 Calculate the mean values of  $X$ ,  $Y_1$  and  $Z$  from the results of the two test portions of unstabilized material, stabilized material and the cement respectively.

NOTE If a sample of the cement used is not available for analysis a value of  $Z$  may be assumed for the purposes of obtaining an approximate indication of the cement content. Typical values of  $Z$  for cements currently available in Great Britain are as given in Table 4.

Table 4 — Typical values of  $Z$

Cement	% as CaO
Portland, complying with BS 12	64.5
Sulphate resisting, complying with BS 4027	64.6
Portland blastfurnace, complying with BS 146	54.2
Portland pfa, complying with BS 6588	47.4

5.1.7.1.3 Using the mean values of  $X$ ,  $Y_1$  and  $Z$  calculate to the nearest 0.1 % the cement content ( $C_1$ ) of the unhydrated stabilized material as a percentage of the mass of the stabilized material from the equation:

$$C_1 = 100(Y_1 - X)/(Z - X)$$

5.1.7.1.4 From the value of  $C_1$  calculate to the nearest 0.1 % the cement content ( $C_2$ ) of the unhydrated stabilized material as a percentage of the dry mass of natural material from the equation:

$$C_2 = 100C_1/(100 - C_1)$$

#### 5.1.7.2 Hydrated stabilized materials

NOTE 1 When Portland cement hydrates it combines eventually with approximately 20 % of its own mass of water and this combined water cannot be driven off by drying at  $105 \pm 5$  °C. For accurate work it is therefore necessary to make an allowance for the presence of water of hydration in the sample.

NOTE 2 The correction given in this clause assumes that the cement is fully hydrated. This is correct only if the cement-stabilized material is several months old. The correction is best omitted if any doubts exist as to the degree of hydration of the cement.

Calculate the calcium content of the unhydrated stabilized material ( $Y_1$ ) from the value obtained for the calcium content of the hydrated material ( $Y_2$ ) from the equation:

$$Y_1 = Y_2 (Z - 1.2X)/(Z - X - 0.2Y_2)$$

Substitute the value of  $Y_1$  in the equation for  $C_1$  in 5.1.7.1.3 and calculate the cement content as described for the case of unhydrated stabilized materials in 5.1.7.1.4.

### 5.1.8 Test report

The test report shall affirm that the cement content was determined in accordance with 5.1 of BS 1924-2:1990 and whether or not a certificate of sampling is available. If available a copy of the certificate of sampling shall be provided. The test report shall contain the following information:

- a) sample identification;
- b) the calcium oxide contents of the unstabilized material, the stabilized material and the cement to the nearest 0.1 %; if a value is assumed for the calcium oxide content of the cement this fact shall be stated;
- c) the cement contents ( $C_1$  and  $C_2$ ) to the nearest 0.2 %;
- d) the approximate age of the material and whether or not an allowance has been made for the hydration of the cement.

## 5.2 Determination of the lime content of lime-stabilized materials

### 5.2.1 Principle

The lime content of the stabilized material is obtained by comparing the calcium contents of the stabilized material, the material in an unstabilized condition and the lime used. It is therefore essential that samples of each of these should be available.

<sup>9)</sup> Whatman No. 541 filter papers are suitable.



NOTE The method is not applicable to materials containing a large or variable amount of calcium compounds or to materials which also contain cement. In such cases it may not be possible to determine the lime content by chemical means.

The requirements of BS 1924-1 shall where appropriate apply to this test method.

### 5.2.2 Sampling

Follow the procedure described in 5.1.3 substituting "lime" wherever reference is made to "cement".

### 5.2.3 Apparatus

With the exception of filter papers and 250 mL beakers all the apparatus listed in 5.1.2 is required.

### 5.2.4 Reagents

With the exception of the (1 + 9) solution of hydrochloric acid all the reagents listed in 5.1.4 are required, and in addition the following.

#### 5.2.4.1 Ammonium chloride (20 % solution).

Dissolve 100 g of ammonium chloride in water and dilute to 500 mL with distilled water or water of equivalent quality.

### 5.2.5 Preparation of test portions

Follow the procedure described in 5.1.5 substituting "lime" wherever reference is made to "cement".

### 5.2.6 Analytical procedure

NOTE The procedure described below should be carried out on each of the test portions of the natural and stabilized materials respectively and of the lime.

#### 5.2.6.1 Preparation of the natural and stabilized material and of the lime

NOTE Two procedures are given for extracting the lime from the stabilized material. Hydrochloric acid is the more effective extractant but with materials of high sesquioxides content it also removes the sesquioxides which may cause interference with the determination of calcium. Ammonium chloride extracts the lime but does not remove the sesquioxides and is, therefore, to be preferred with materials of high sesquioxide content, even though it may take up to 15 min longer to extract the lime from the sample compared with the 2 min to 3 min taken with hydrochloric acid. In general, ammonium chloride should be used in cases where material containing no calcium and a high proportion of iron or aluminium has been stabilized with a low proportion of lime. Such a combination is likely to arise, for example, with tropical soils such as laterites rich in iron and aluminium.

**5.2.6.1.1** For materials of low sesquioxide content where the effects of co-precipitation can be ignored follow the procedure given respectively in 5.1.6.1 for the test portions of natural and stabilized material and 5.1.6.2 for the test portions of lime.

**5.2.6.1.2** For materials of high sesquioxide content where co-precipitation of calcium is a probability, follow the procedure given in 5.2.7.1 for the test portions of natural and stabilized material but use a 20 % solution of ammonium chloride in place of the (1 + 1) hydrochloric acid as the extractant. Boil the test portions in a fume cupboard with the appropriate quantity of ammonium chloride solution until no further evolution of ammonia occurs. This can be checked by holding a moistened red litmus paper over the mouth of the beaker: the paper will turn blue if ammonia is still being evolved. Take care during boiling to ensure that the solution is not boiled dry, and if necessary add additional water to prevent this occurring.

**5.2.6.2 Analysis of the acid or ammonium chloride extracts.** Drop a small piece of litmus paper into each volumetric flask and add (1 + 4) ammonia solution (preferably from a burette) until the litmus changes from red to blue (this may not be necessary if ammonium chloride was used as the extractant). After the addition of the ammonia solution adjust the volume of the suspension to exactly 250 mL with distilled water and thoroughly mix the contents of the flask by shaking. Set the flask aside until the precipitate has settled to the bottom; when it has settled remove 50 mL of the clear supernatant liquid by means of a pipette and place in a 250 mL conical flask or beaker. Dilute to about 150 mL, add 10 mL of the triethanolamine solution, 10 mL of the sodium hydroxide solution and about 0.15 g screened calcein indicator. Titrate with standard EDTA solution, using magnetic stirring if possible, until the fluorescent green of the indicator completes the change to pink-purple with no residual fluorescence (see 5.1.4.3). Record the volume ( $V$ ) of the EDTA used in the titration to the nearest 0.02 mL.

### 5.2.7 Calculations and expression of results

NOTE A typical data and calculation form for the determination of the lime content of lime-stabilized materials is given in form P of Appendix A.

Calculate the lime content ( $L_1$ ) in a similar manner to that used for unhydrated cement-stabilized materials in 5.1.7.1. In this instance  $L_1$  and  $L_2$  correspond to  $C_1$  and  $C_2$  and  $X$ ,  $Y$  and  $Z$  correspond to the natural material, uncarbonated lime-stabilized material and lime respectively.

NOTE In theory an allowance should be made (other than for a freshly mixed sample) for the increase in mass of the sample arising from carbonation of the lime and its pozzolanic reaction with the material. This is analogous to the correction to allow for hydration in the case of cement-stabilized materials. In practice it is difficult to determine how much carbonation and/or pozzolanic reaction has occurred so a value of  $L_2$  cannot usually be calculated.

### 5.2.8 Test report

The test report shall affirm that the lime content was determined in accordance with 5.2 of BS 1924-2:1990 and whether or not a certificate of sampling is available. If available a copy of the certificate of sampling shall be provided. The test report shall contain the following information:

- a) sample identification;
- b) the calcium oxide contents of the unstabilized material, the stabilized material and the lime to the nearest 0.1 %; if a value is assumed for the calcium oxide content of the lime this fact shall be stated;
- c) the lime content to the nearest 0.2 %;
- d) the approximate age of the material and whether or not an allowance has been made for the carbonation or pozzolanic reaction of the lime.

## 5.3 Determination of the in situ pH of lime- or cement-stabilized materials as a guide to the degree of carbonation

### 5.3.1 Principle

The pH of lime- or cement-stabilized materials will remain at values in excess of 12 whilst any unreacted lime or cement remains. Even when the cement or lime has completely reacted with water and with any pozzolanic materials present high pH values will still prevail. On longterm exposure to air the hydration products may, under adverse conditions, react with carbon dioxide causing a large decrease in pH and possible loss in strength. Carbonation is the most probable cause of decreases to pH values below 9.0 and determination of the pH value of an exposed surface of the stabilized material therefore gives a rapid assessment of whether or not carbonation is likely to have occurred.

In this method the extent to which carbonation may have occurred is assessed by exposing a surface of the stabilized layer. The pH value of the exposed layer is then determined by spraying the exposed surface with solutions of suitable acid-base indicators possessing different colours according to alkalinity or pH value.

The requirements of BS 1924-1 shall where appropriate apply to this test method.

### 5.3.2 Apparatus

**5.3.2.1** *Equipment for digging holes* in the stabilized layer to the full depth of construction.

**5.3.2.2** *A stiff brush*, for brushing and removing loose material from the exposed layer of stabilized material.

**5.3.2.3** *Four plastics spray bottles*,

e.g. hand-operated garden sprays with a capacity of about 500 mL.

NOTE It is important that these bottles do not have any metal parts that can come into contact with their contents.

### 5.3.3 Reagents

NOTE Only reagents of recognized analytical quality and distilled water or water of equivalent quality should be used. The solutions should be stored in the plastics spray bottles, and the fourth bottle used for storing a supply of distilled water.

**5.3.3.1** *Hydrochloric acid (1 + 3) solution.*

Dilute 330 mL of concentrated hydrochloric acid (relative density 1.18) to 1 L with distilled water.

**5.3.3.2** *Phenolphthalein solution.* Dissolve 5 g of the reagent in 500 mL of ethanol (95 %) and add 500 mL of distilled water with constant stirring. Filter if a precipitate forms.

NOTE Phenolphthalein is colourless below a pH of 8.3 and deep red above a pH of 10.0.

**5.3.3.3** *Phenol red solution.* Dissolve 0.2 g of phenol red powder in 60 mL of 0.01 M solution of sodium hydroxide (0.40 g/L). Make up to 500 mL with distilled water.

NOTE Phenol red solution is yellow below a pH of 6.8 and red above a pH of 8.4.

### 5.3.4 Procedure

**5.3.4.1** Expose a surface of the stabilized layer and remove all loose material from the surface.

**5.3.4.2** Spray the exposed surface with water and ensure that it is thoroughly moist.

**5.3.4.3** Spray the full depth of the treated layer evenly with phenolphthalein until it is visibly wet, paying particular attention to interfaces and cracks. A red colour shows the pH to be above 8.3 suggesting that lime is present. Record the presence or absence of a red coloration, if there are only patches of red draw a diagram to record the areas of red coloration.

**5.3.4.4** If the whole of the exposed surface did not show a red coloration when sprayed with phenolphthalein spray the surface with phenol red solution. Record the absence of a red coloration in those areas which did not turn red when sprayed with phenolphthalein.

**5.3.4.5** Spray the whole of the exposed surface with the (1 + 3) hydrochloric acid. Effervescence indicates the presence of a carbonate. Record the depths over which effervescence ceased or became markedly less.

**5.3.4.6** Repeat operations 5.3.4.1 to 5.3.4.5 on other exposed surfaces of the stabilized layer.

**5.3.4.7** If possible check whether or not carbonates were present in the original unstabilized material by treating a sample of the unstabilized material with the hydrochloric acid. Effervescence indicates that carbonates were present in the unstabilized material.

### 5.3.5 Reporting of results

Report the results as one of the following:

- a) red colour with phenolphthalein, no effervescence with hydrochloric acid;

NOTE This indicates that no carbonation has occurred and that carbonates were absent from the original materials.

- b) red colour with phenolphthalein, effervescence with hydrochloric acid;

NOTE This indicates that carbonates were probably present in the original materials but that in this case partial carbonation cannot be ruled out. If it is known that carbonates were not present in the original material some partial carbonation must have occurred.

- c) no colour change with phenolphthalein, red colour with phenol red effervescence with hydrochloric acid;

NOTE 1 If it is known that carbonates were not present in the original material this indicates that carbonation of the stabilizer has occurred. However, if carbonates were present in the original material it is not possible to distinguish between whether carbonation has occurred or whether the stabilizer was not added.

NOTE 2 Phenol red cannot always be relied upon to give clearly discernible colour changes.

- d) no colour changes with phenolphthalein or phenol red no effervescence with hydrochloric acid.

NOTE This indicates that the stabilizer was not added. If it is suspected that stabilizer was not added a qualitative test for the presence of calcium should be made. The absence of calcium is positive proof that no stabilizer was added.

### 5.3.6 Test report

This test is a rapid field test for assessing the degree to which carbonation has occurred and a full test report as required for other tests included in this standard is not appropriate. The test report shall include all the relevant facts that led to the conclusions being made.

## 5.4 Determination of the initial consumption of lime

NOTE The initial consumption of lime (ICL) test developed by Eades and Grim can be used to give an indication of the minimum amount of lime that is required to be added to a material to achieve a significant change in its properties. The method does not dispense with the need to establish the relation between the lime content and strength (or plasticity) but by giving an indication of the minimum amount of lime likely to prove necessary it reduces the range of lime contents to be examined.

### 5.4.1 Principle

A saturated solution of lime (calcium hydroxide) in distilled water completely free of carbon dioxide has a pH value of 12.40 at 25 °C. This pH is required to maintain reaction between the lime and any reactive components in the material to be stabilized. Samples of the material are therefore mixed with water and different proportions of the lime being used and the minimum amount of lime needed to give a pH of 12.40 is expressed as the ICL of the material.

The requirements of BS 1924-1 shall where appropriate apply to this test method.

### 5.4.2 Sampling

**5.4.2.1** The sample received at the laboratory (the laboratory sample) shall be taken in accordance with the procedure described in 5.3 of BS 1924-1:1990.

**5.4.2.2** Reduce the sample by the procedures described in 5.4 of BS 1924-1:1990 to produce a test portion which after being dried at  $105 \pm 5$  °C and sieved on a 425  $\mu\text{m}$  test sieve has a mass of about 200 g (see 5.4.7).

### 5.4.3 Apparatus

**5.4.3.1** A *pH meter*, fitted with a suitable glass electrode system for use up to pH values of 13.0 readable to 0.05 pH unit.

NOTE pH meter electrodes are extremely fragile and great care therefore should be taken with their use. It is essential to use electrodes that are suitable for highly alkaline solutions.

**5.4.3.2** A *balance*, of 250 g minimum capacity readable to 0.01 g.

**5.4.3.3** A *temperature-controlled oven*, capable of maintaining a temperature of  $105 \pm 50$  °C.

**5.4.3.4** *Glass or plastics bottles*, of 250 mL capacity fitted with watertight stoppers (at least six are required).

**5.4.3.5** An *end-over-end bottle shaker*, or other suitable means of keeping a suspension of stabilized material placed in the bottles in continuous agitation (optional).

**5.4.3.6** A 425  $\mu\text{m}$  *test sieve*, with receiver complying with 4.2.4.2 of BS 1924-1:1990.

**5.4.3.7** A *thermometer*, covering the range 15 °C to 25 °C readable to 0.5 °C.

**5.4.3.8** *Two airtight containers*, for storing lime, e.g. 1 kg preserving jars.

**5.4.3.9** A 100 mL *capacity measuring cylinder*.

**5.4.3.10** A *wash bottle*, containing distilled water.

**5.4.3.11** A *beaker*, of 50 mL to 100 mL capacity, preferably made of plastics.

**5.4.3.12** *Soft paper tissues*.

#### 5.4.4 Reagents

NOTE All reagents should be of recognized analytical reagent quality.

**5.4.4.1 Buffer solution pH 4.00.** Dissolve 2.55 g of potassium hydrogen phthalate in distilled water and dilute to 350 mL, using a volumetric flask.

Alternatively use a solution prepared from proprietary materials, e.g. buffer solution tablets.

NOTE The buffer solution should be stored in a plastics container and any portions used should be discarded. The buffer solution should not be kept for more than 7 days.

**5.4.4.2 Buffer solution pH 9.20.** Dissolve 4.99 g of disodium tetraborate (borax) in distilled water and dilute to 250 mL, using a volumetric flask.

Alternatively use a solution prepared from proprietary materials, e.g. buffer solution tablets.

NOTE The buffer solution should be stored in a plastics container and any portions used should be discarded. The buffer solution should not be kept for more than 7 days. The solution at pH 9.20 has been specified because it is readily available and easily prepared. If a buffer solution with a higher pH value can be obtained it may, with advantage, be used.

**5.4.4.3 Potassium chloride.** Prepare a saturated solution and use to maintain the calomel electrode of the pH meter in accordance with the manufacturer's instructions.

**5.4.4.4 Dilute hydrochloric acid.** Dilute 100 mL of the concentrated acid to 500 mL with distilled water.

**5.4.4.5 Distilled water,** free of carbon dioxide. Gently boil the required quantity of distilled water for one hour and allow to cool to room temperature without access to air before use. Use this water within 24 h of preparation.

NOTE Caution is required during the cooling stage to ensure that no partial vacuum occurs in the cooling vessel. A beaker covered with a clock glass is a suitable cooling vessel provided the water is used within 24 h.

**5.4.4.6 Calcium hydroxide** of laboratory grade; store in an airtight container.

**5.4.4.7 Lime,** for the stabilization work (see note to 5.4.6); store in an airtight container.

#### 5.4.5 Calibration and use of the pH meter

**5.4.5.1** Calibrate the pH meter with the standard buffer solutions following the procedure recommended by the manufacturer. Check the calibration of the pH meter with the standard pH 9.2 buffer solution a few minutes before and after each set of pH determinations. If the instrument is out of adjustment by more than 0.05 unit, the results shall be discarded and the test repeated.

**5.4.5.2** When using pH meters not fitted with automatic temperature compensation, adjust the instrument correctly according to the temperature of the solutions before taking a reading. Before insertion into any solution wash the electrodes thoroughly with distilled water and carefully remove the surplus water with clean absorbent paper tissues. In addition wash the electrodes with distilled water immediately after removal from any solution. When not in use keep the electrodes in distilled water.

NOTE After several readings the electrodes may become encrusted with calcium carbonate. This can be removed by immersing them in dilute hydrochloric acid. After immersion in acid wash the electrodes thoroughly and recalibrate using the pH 9.2 buffer solution.

**5.4.5.3** Prepare a saturated solution of the calcium hydroxide by placing about 5 g of calcium hydroxide in one of the bottles. Add 100 mL of CO<sub>2</sub>-free distilled water and shake in the shaking machine (5.4.3.5) for 60 min. (If the machine is not available shake the bottle manually for 30 s every 10 min for the first hour and then every hour for 4 h.) Leave the suspension in the tightly stoppered bottle for 24 h before use. Pour the suspension into a beaker and determine its pH to the nearest 0.05 unit and record its temperature to the nearest 0.5 °C. Calculate the pH value of the solution at 25 °C (pH<sub>25</sub>) from the equation:

$$\text{pH}_{25} = \text{pH}_T + 0.03(T - 25)$$

where

pH<sub>T</sub> is the pH at measured temperature *T* °C.

If the pH value at 25 °C is in the range 12.35 to 12.45 the pH meter and electrode system is suitable for the test. If not check that the lime is of a good quality grade before investigating any possible defects in the pH meter and/or the electrodes.

NOTE It is not necessary to carry out this procedure every time. The system should be checked before first use and every time a new electrode is used but once it has been found to be suitable no further tests with the calcium hydroxide need to be made.

#### 5.4.6 Determination of the suitability of the lime

Prepare a saturated solution of the lime that is to be used for the test (see note) by the procedure described for calcium hydroxide in 5.4.5.3.

Determine the pH value of the solution by the same procedure described for calcium hydroxide in 5.4.5.3. If the pH value of the saturated solution at 25 °C is in the range 12.35 to 12.45 the lime is suitable for use. If it is not and all the conditions of 5.4.5 have been satisfied the quality of the lime for the purposes of lime-stabilization is suspect and results of any ICL test carried out with it are meaningless.

NOTE If the results of the ICL test are to be related to practice it is essential that a sample of the lime that is to be used is available. However, if the test is being carried out to determine the potential of the material for stabilization and no sample of the lime to be used is available, the test may be carried out with the calcium hydroxide given in 5.4.4.6.

#### 5.4.7 Test procedure

**5.4.7.1** Take the dried and sieved test portion obtained as described in 5.4.2.2 (see note 1) and subdivide it into two representative halves each weighing about 100 g. Take one of these to provide five test specimens each with a mass of about 20.0 g weighed to the nearest 0.1 g. Place each test specimen into each of five bottles and weigh out to the nearest 0.01 g the lime to be used in the test in the proportions 2.0 %, 3.0 %, 4.0 %, 5.0 %, 6.0 % (see note 2). Add the lime to the bottles and shake the bottles to mix the lime with the material.

NOTE 1 If the proportion of material retained on the 425  $\mu\text{m}$  test sieve is not known from the results of a prior determination of the particle size distribution it will be necessary to ascertain the amount retained at this stage. It is assumed in this test that the lime-reactive fraction of the material is concentrated in the fraction finer than 425  $\mu\text{m}$  in particle size.

NOTE 2 The proportions chosen will ensure that in most cases the percentage of lime required will be included in the first trial.

**5.4.7.2** Add  $100 \pm 2$  mL of  $\text{CO}_2$ -free distilled water to each bottle. Shake the bottle and contents until there is no evidence of dry material on the bottom.

**5.4.7.3** If a shaking device is available shake the bottles for 15 min. If not, shake the bottles manually for 30 s every 10 min for 1 h. In either case after  $1 \text{ h} \pm 5 \text{ min}$  determine the pH values of the suspensions as described for calcium hydroxide in 5.4.5.2 and 5.4.5.3.

**5.4.7.4** If none of the suspensions reaches a pH value above 12.30 (corrected to 25 °C) but this value is obtained with the addition of 2 % of lime, carry out additional tests with lower values of lime addition. If the pH values go up to 12.40 but this value is not reached until at least 5 % of lime has been added, repeat the test with higher proportions of lime (see note). If a pH value of 12.4 is achieved with as little as 3.0 % of lime, repeat the test using additional lime contents of 0.5 %, 1.0 %, 1.5 % and 2.5 %.

NOTE Before proceeding with the test an assessment needs to be made as to whether or not it will be economic to add lime in proportions much higher than 6 %.

#### 5.4.8 Calculations and expression of results

NOTE A typical data and calculation form for the determination of the initial consumption of lime is given in form Q of Appendix A.

**5.4.8.1** Plot the percentage of lime added to the material against the pH (corrected to 25 °C) and read-off, by interpolation, the proportion of lime required to give pH values of 12.30 and 12.40.

**5.4.8.2** If the pH readings go to pH 12.40 record to the nearest 0.1 % the lowest percentage of lime that gives this value as the ICL of the material (see notes 1 and 2).

**5.4.8.3** If the pH readings do not go beyond pH 12.30 but this value is obtained from the addition of 2 % of lime (or less), record to the nearest 0.1 % the lowest percentage of lime that gives this value as the ICL of the material.

NOTE 1 When using the ICL values to carry out further tests remember that the values refer only to the fraction of material finer than 425  $\mu\text{m}$  in particle size and make due allowance for this.

NOTE 2 If quicklime is to be used in the field but has not been used in the test then the hydrated lime percentage obtained should be multiplied by 0.75 to give the quicklime addition. Similarly allowance should be made for the available lime content of the lime used in the field if this differs from the available lime content used in the laboratory.

#### 5.4.9 Test report

The test report shall affirm that the initial consumption of lime (ICL) was determined in accordance with 5.4 of BS 1924-2:1990 and whether or not a certificate of sampling is available, if available a copy of the certificate of sampling shall be provided. The test report shall also contain the following additional information:

- sample identification;
- details of the lime used for the test;
- the graph showing the relation between pH and lime content and, in those cases where it can be calculated, the ICL value to the nearest 0.1 percent;
- the proportion of material passing the 425  $\mu\text{m}$  test sieve.

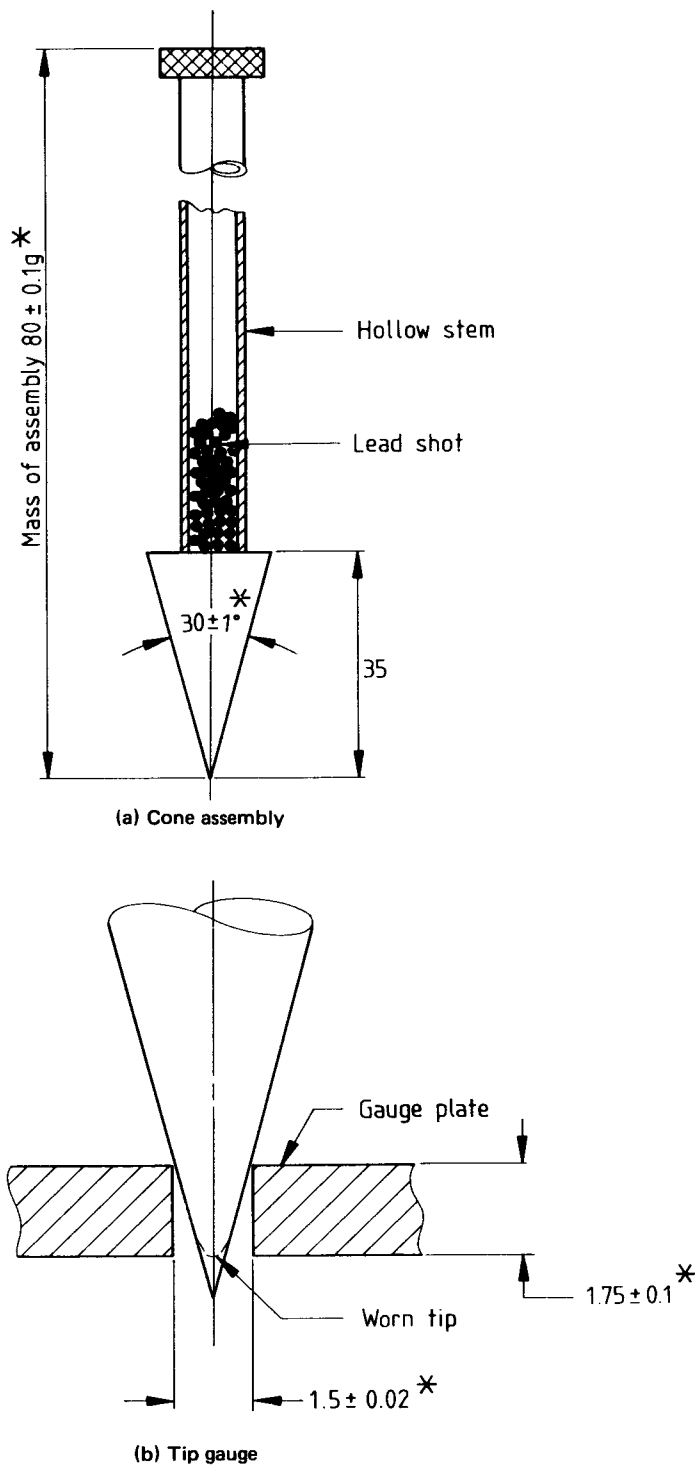

See 4.2.2 of BS 1924-1:1990.  
 All linear dimensions are in millimetres.

**Figure 1 — Details of cone for the liquid limit test**

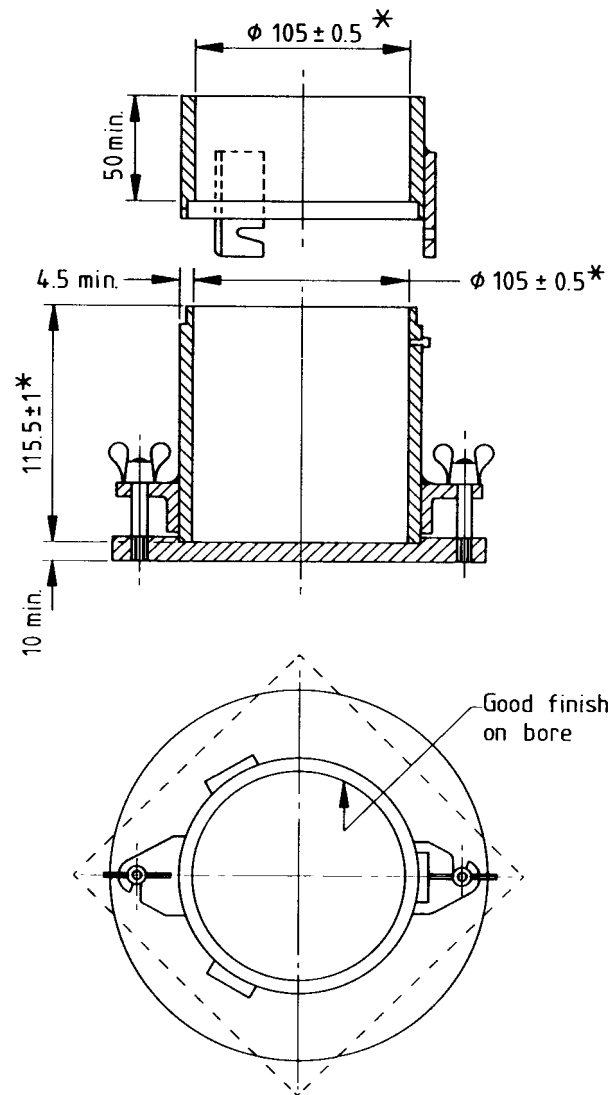

All dimensions are in millimetres.

\*See 4.2.2 of BS 1924-1:1990.

NOTE This design has been found satisfactory, but alternative designs may be employed provided that the essential requirements are fulfilled.

**Figure 2 — Mould for the compaction test (1 L mould)**

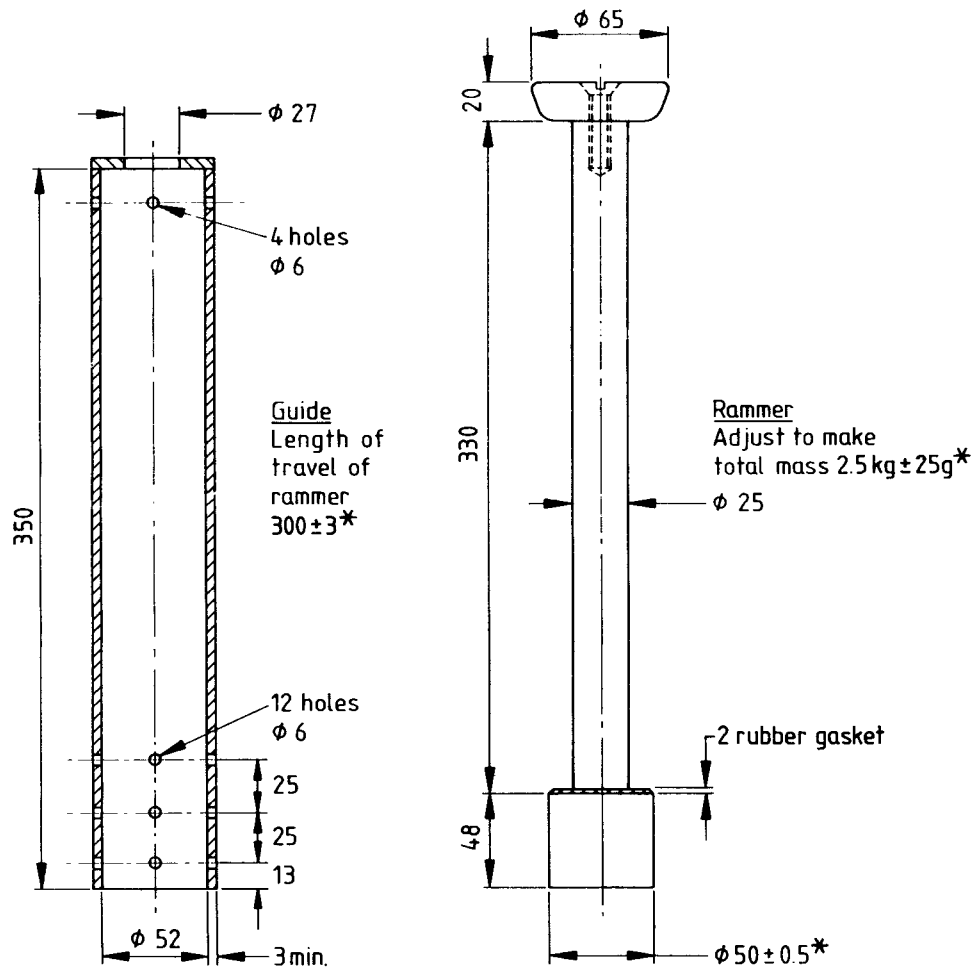

All dimensions are in millimetres.

\*See 4.2.2 of BS 1924-1:1990.

NOTE This design has been found satisfactory, but alternative designs may be employed provided that the essential requirements are fulfilled.

Figure 3 — 2.5 kg rammer for the compaction test



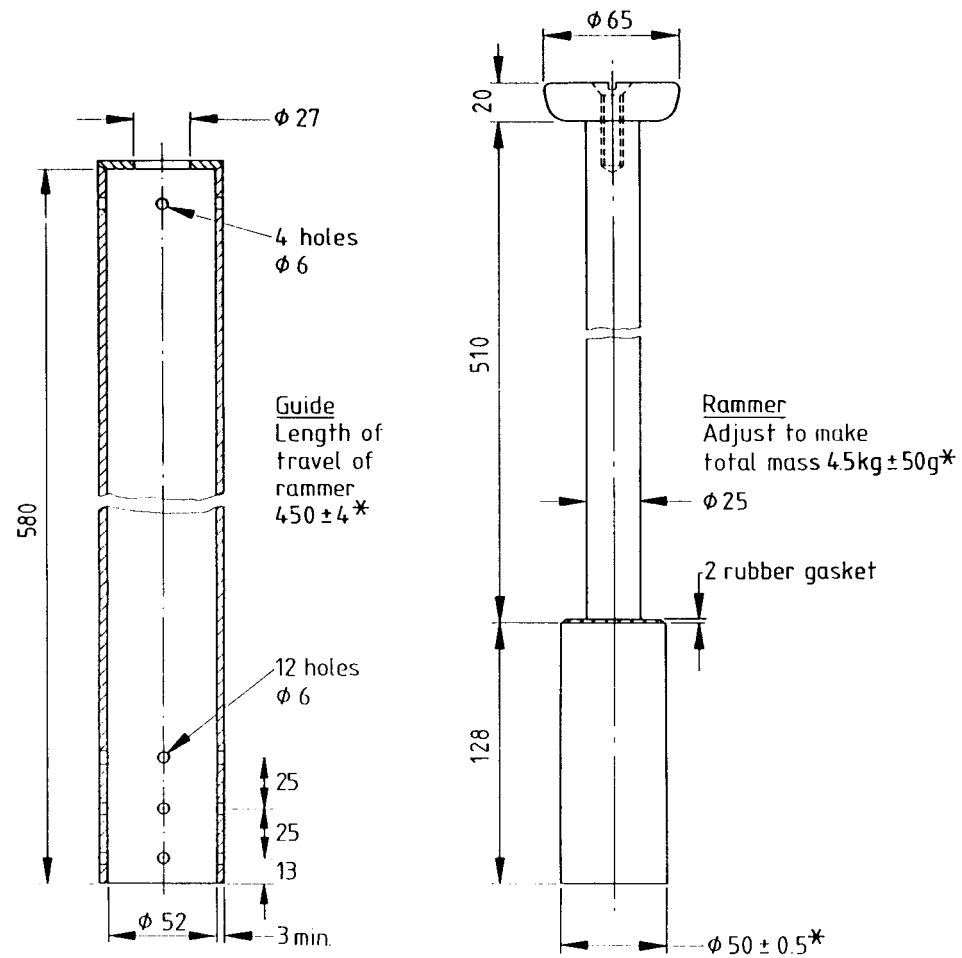

All dimensions are in millimetres.

\*See 4.2.2 of BS 1924-1:1990.

NOTE This design has been found satisfactory, but alternative designs may be employed provided that the essential requirements are fulfilled.

**Figure 4 — 4.5 kg rammer for the compaction test**

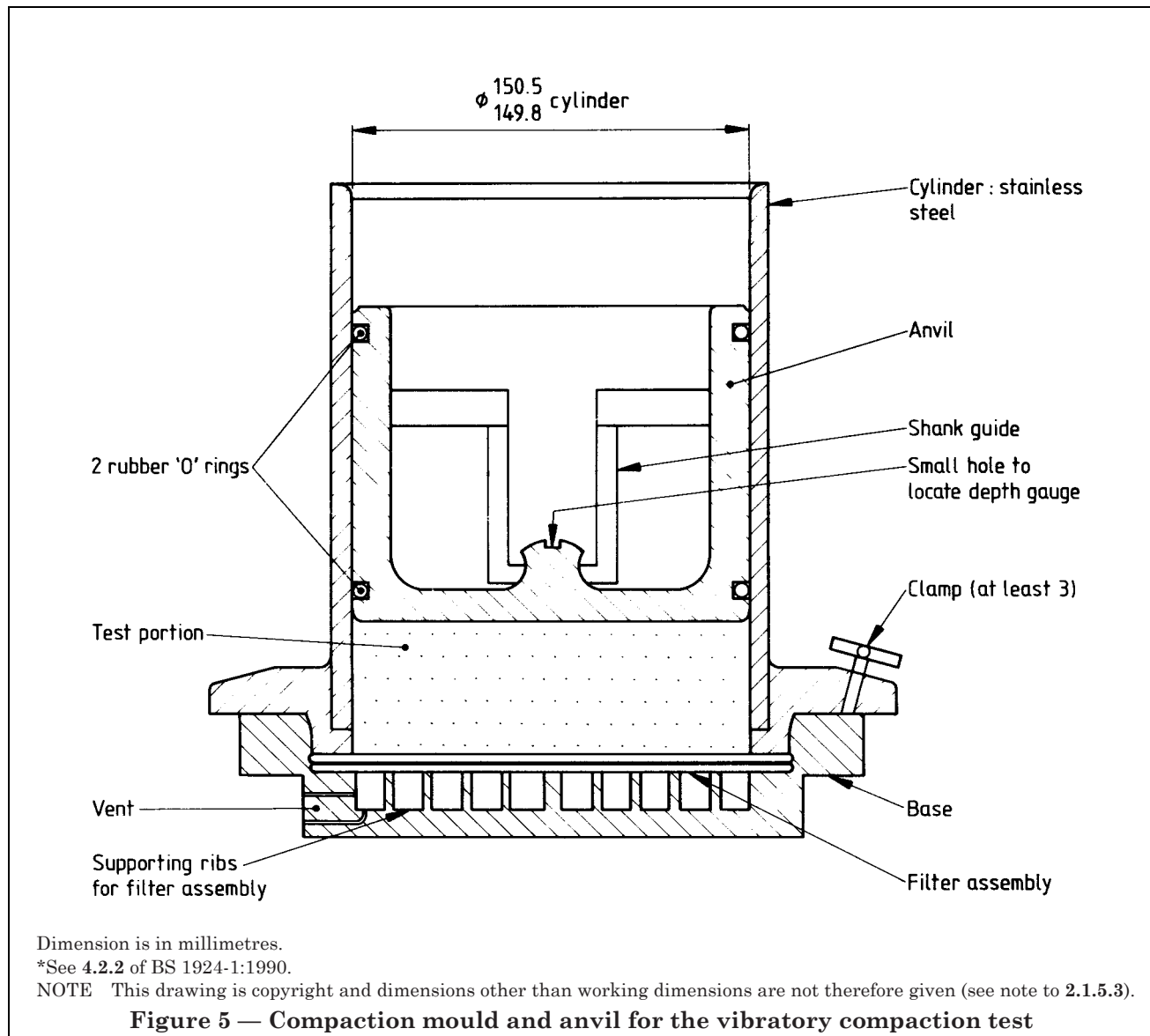

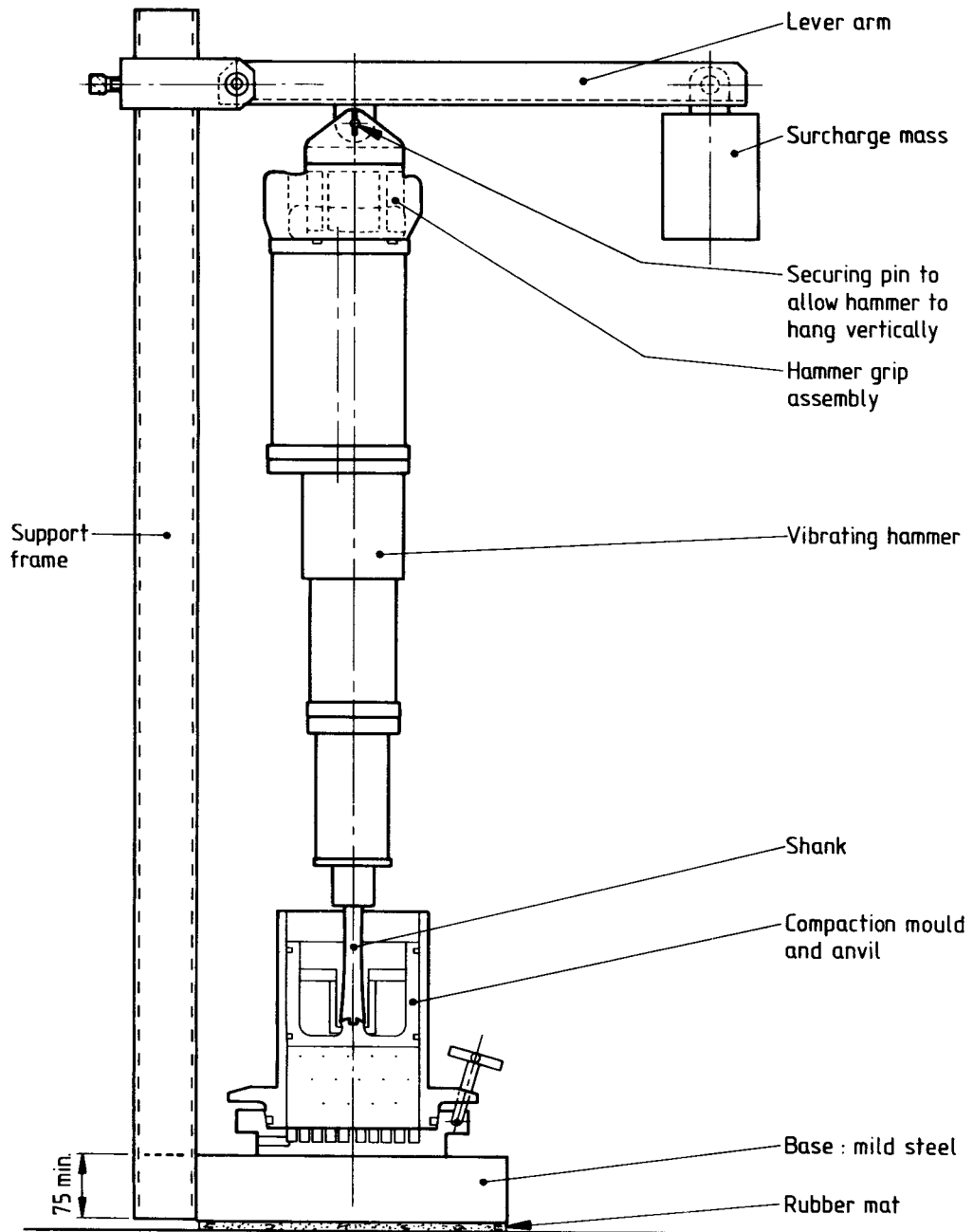

Dimension is in millimetres.

\*See 4.2.2 of BS 1924-1:1990.

NOTE This design of the compaction mould and anvil is copyright (see note to 2.1.5.3).

**Figure 6 — Compaction rig assembly**

(a) For use with the compaction mould

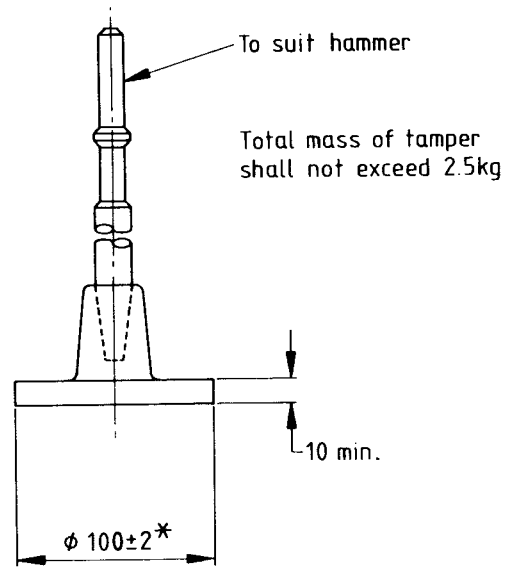

(b) For use with the CBR mould

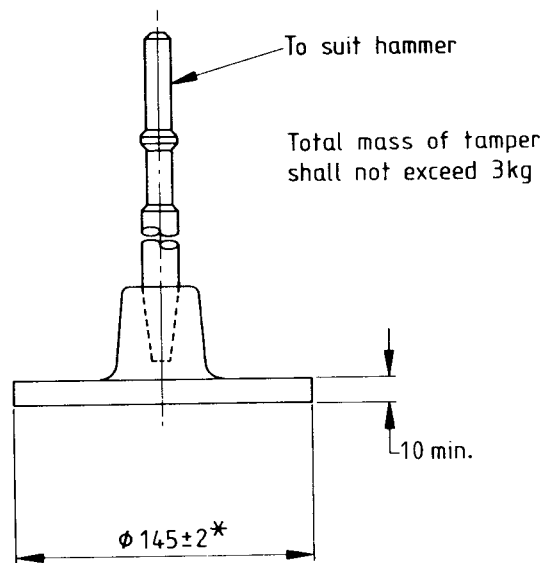

\*See 4.2.2 of BS 1924-1:1990.  
All dimensions are in millimetres.

Figure 7 — Tampers for the vibrating hammer test

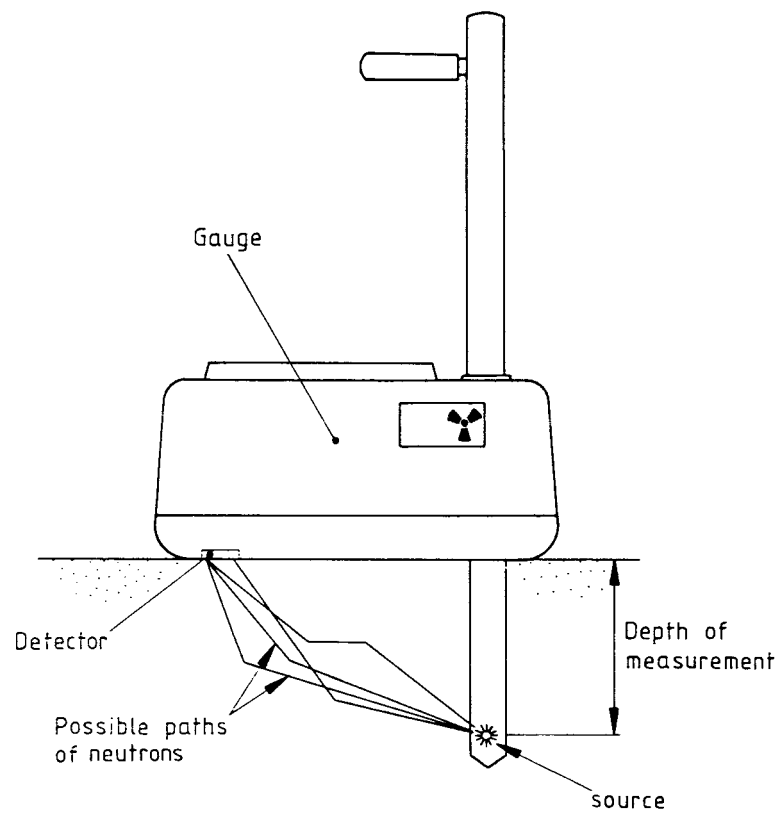
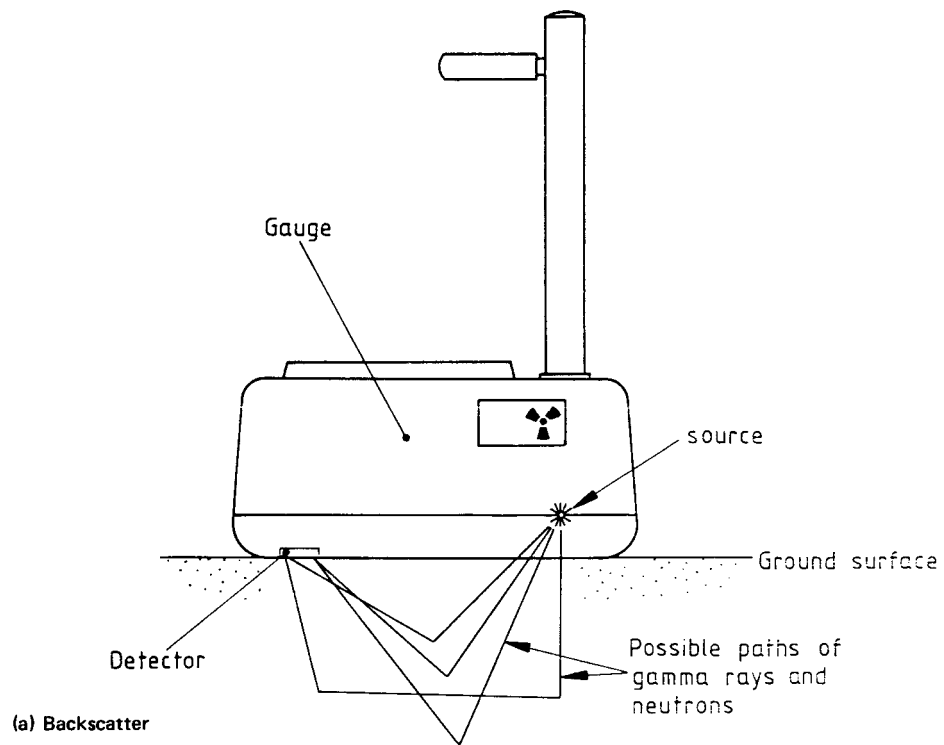
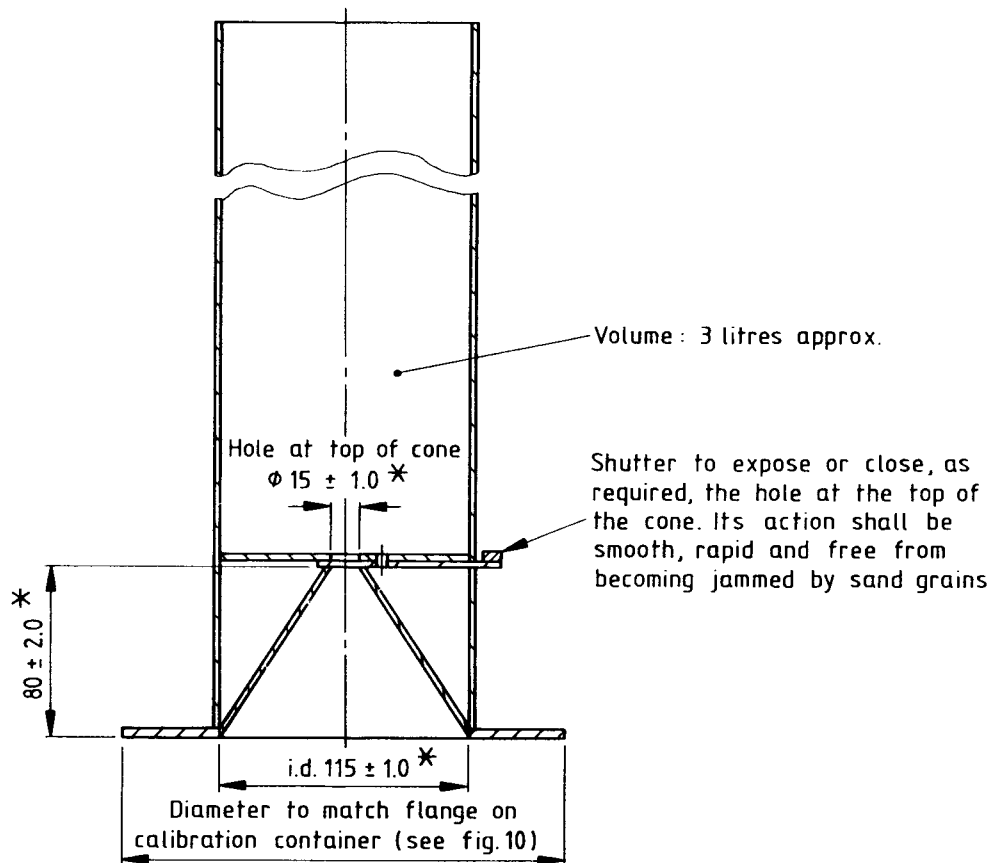

Figure 8 — Two methods of transmission with nuclear surface density gauge



\*See 4.2.2 of BS 1924-1:1990.

All dimensions are in millimetres.

NOTE This design has been found satisfactory, but alternative designs may be employed provided that the essential requirements are fulfilled.

**Figure 9 — Small pouring cylinder for the determination of the density of fine- and medium-grained materials**

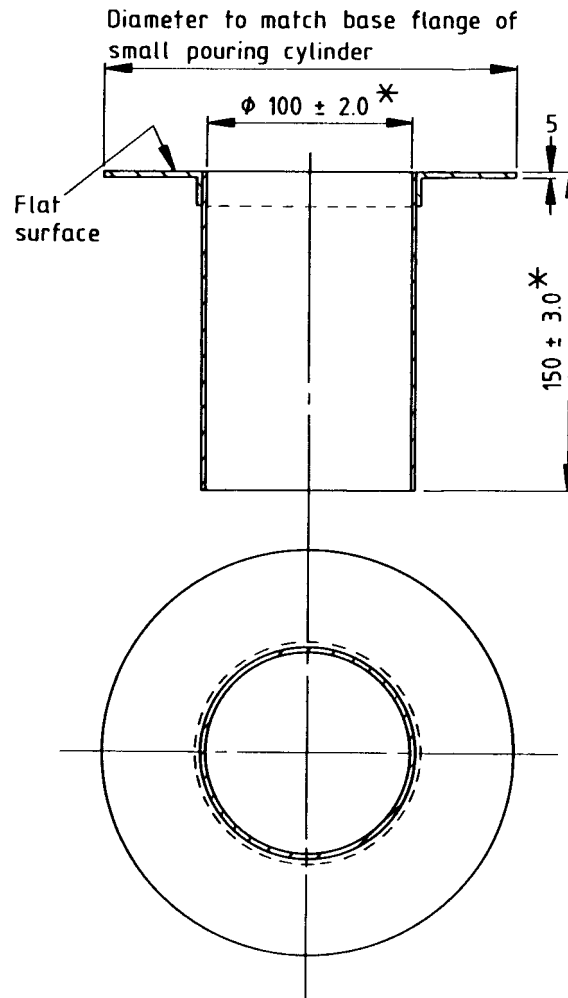

\*See 4.2.2 of BS 1924-1:1990.

All dimensions are in millimetres.

NOTE 1 It is important that metal joints within the calibrating container do not form crevices because these will affect the accuracy of the calibration.

NOTE 2 This design has been found satisfactory, but alternative designs may be employed, provided that the essential requirements are fulfilled.

**Figure 10 — Calibrating container for use with the small pouring cylinder**

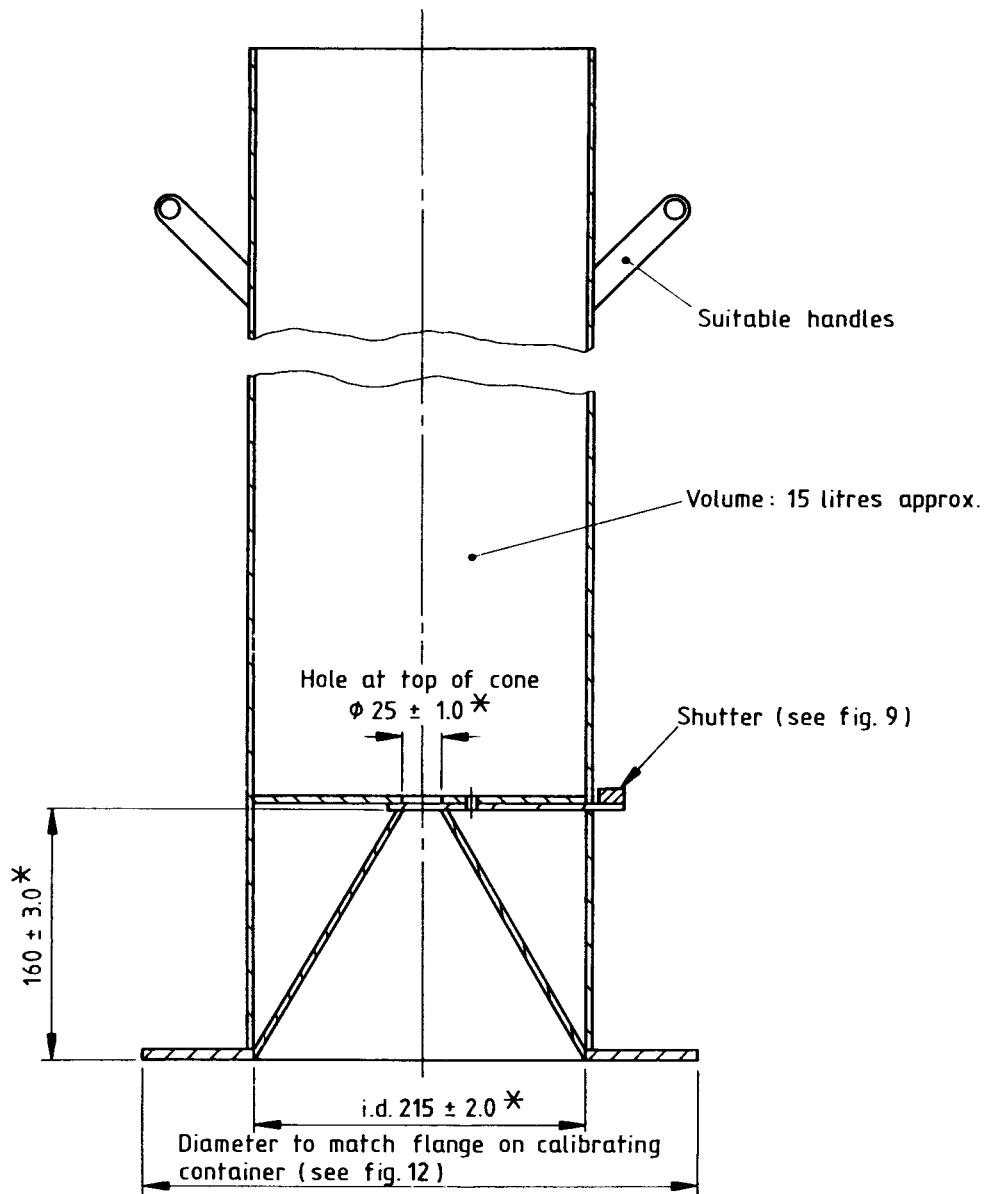

\*See 4.2.2 of BS 1924-1:1990.

All dimensions are in millimetres.

NOTE This design has been found satisfactory, but alternative designs may be employed provided that the essential requirements are fulfilled.

**Figure 11 — Large pouring cylinder for the determination of the density of medium- and coarse-grained materials**



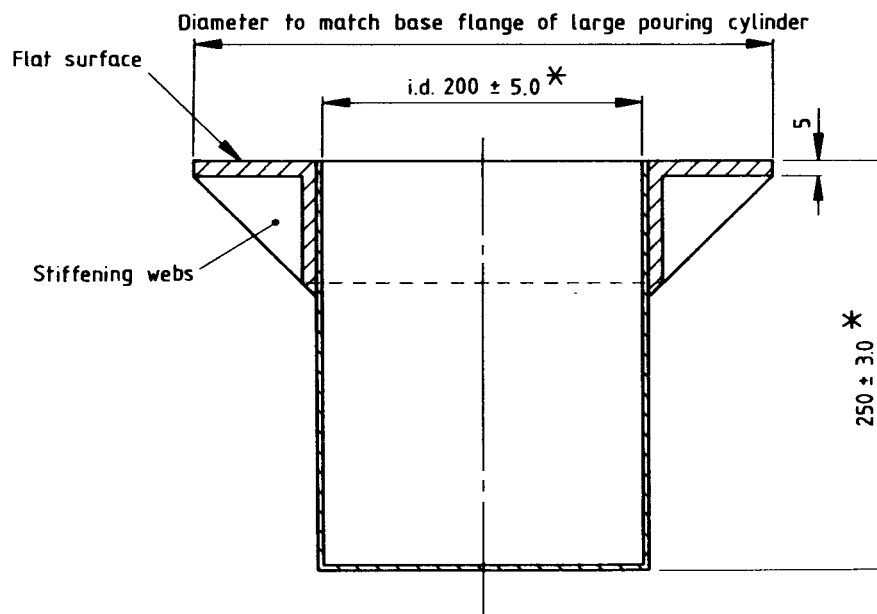

\*See 4.2.2 of BS 1924-1:1990.

All dimensions are in millimetres.

NOTE 1 It is important that metal joints within the calibrating container do not form crevices because these will affect the accuracy of the calibration.

NOTE 2 This design has been found satisfactory, but alternative designs may be employed provided that the essential requirements are fulfilled.

**Figure 12 — Calibrating container for use with the large pouring cylinder**

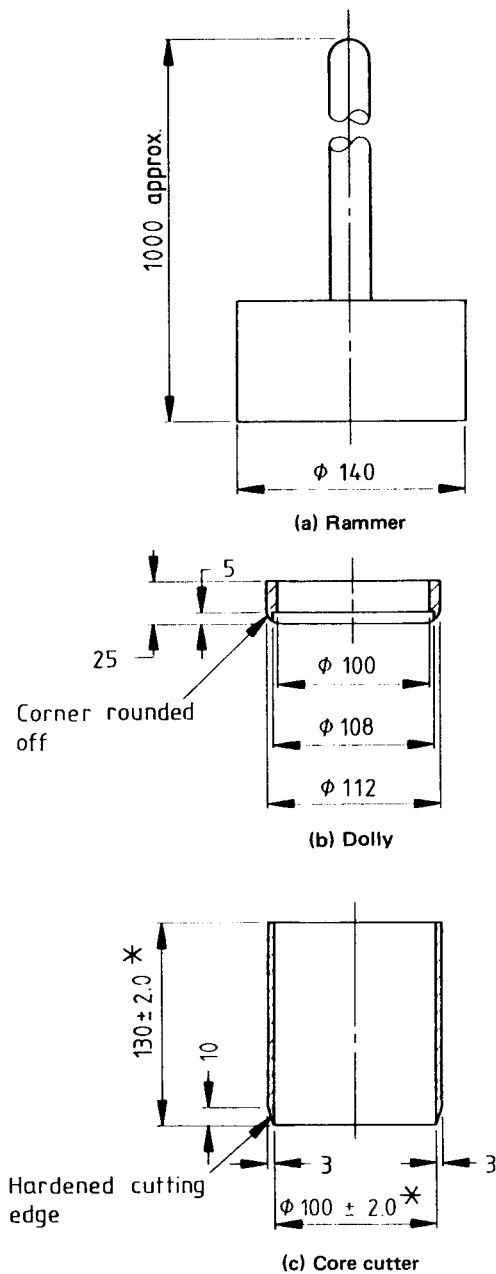

\*See 4.2.2 of BS 1924-1:1990.

All dimensions are in millimetres.

NOTE This design has been found satisfactory, but alternative designs may be employed provided that the essential requirements are fulfilled.

**Figure 13 — Core-cutter apparatus for in-situ density determination of fine-grained materials**

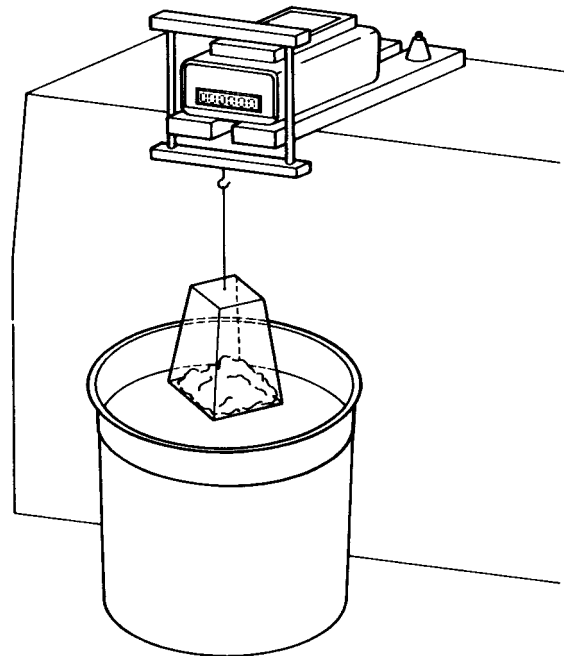
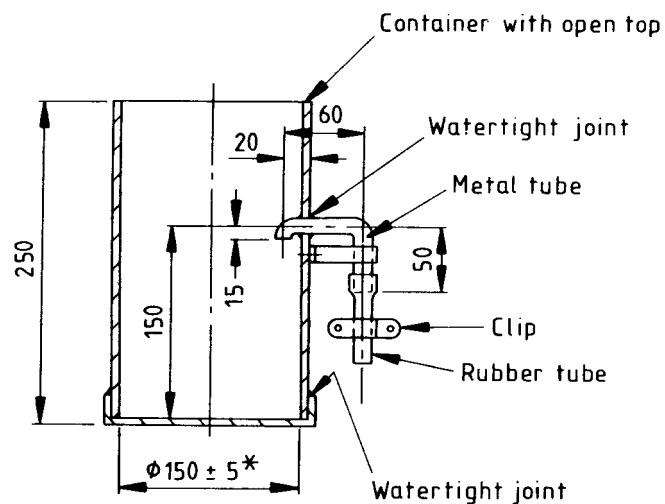

Figure 14 — Diagrammatic representation of the cradle and supporting frame for determination of density by the immersion-in-water method



\*See 4.2.2 of BS 1924-1:1990.

All dimensions are in millimetres.

NOTE This design has been found satisfactory, but alternative designs may be employed, provided that the essential requirements are fulfilled.

Figure 15 — Apparatus for the determination of density of stabilized material by water displacement (fine- and medium-grained materials)

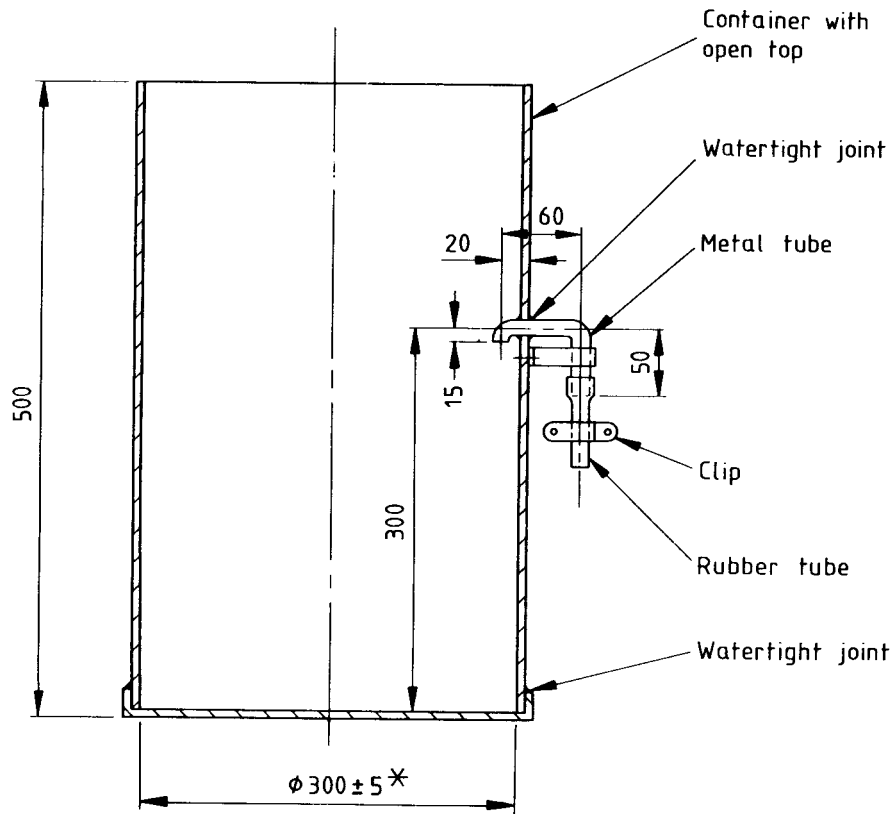

\*See 4.2.2 of BS 1924-1:1990.

All dimensions are in millimetres.

NOTE This design has been found satisfactory, but alternative designs may be employed, provided that the essential requirements are fulfilled.

**Figure 16 — Apparatus for the determination of density of stabilized material by water displacement (coarse-grained materials)**

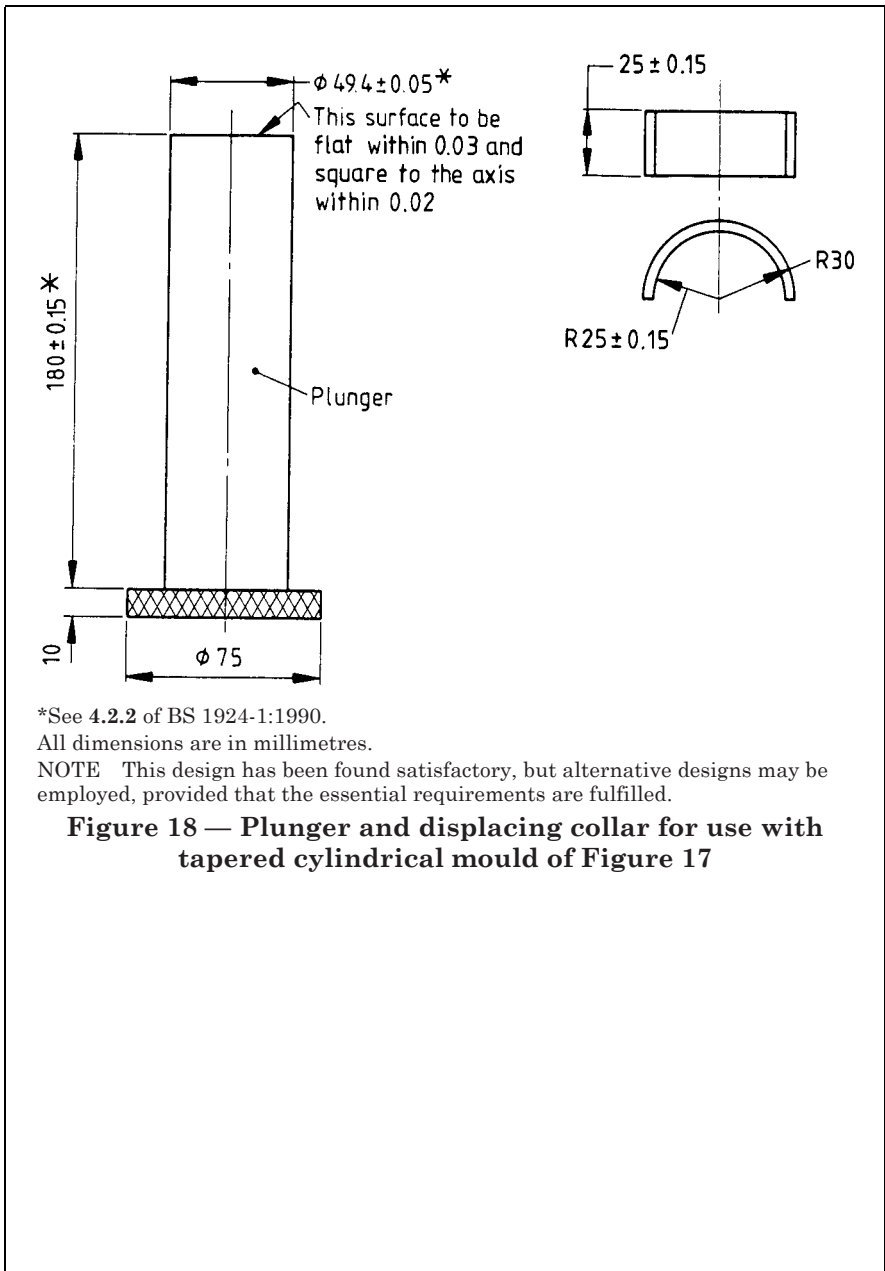
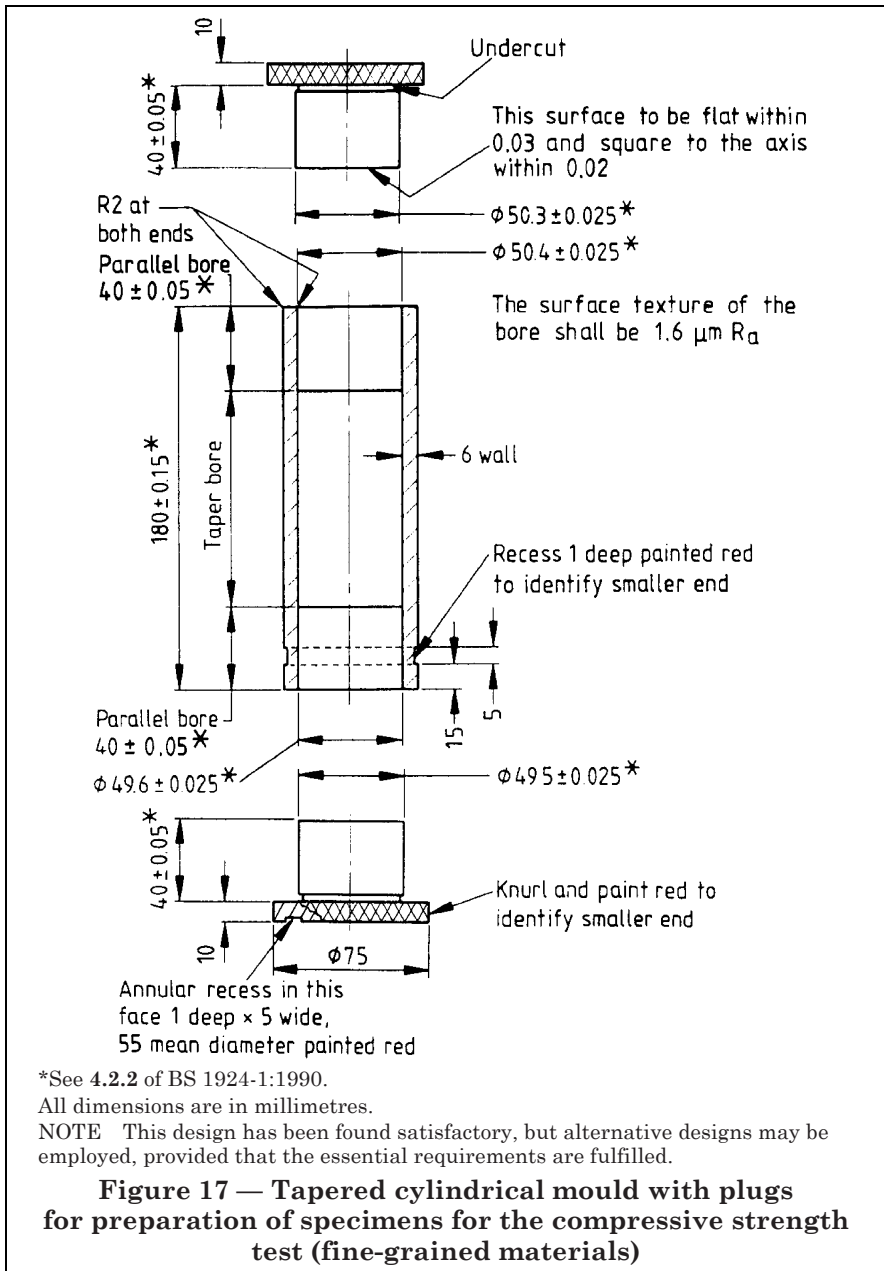

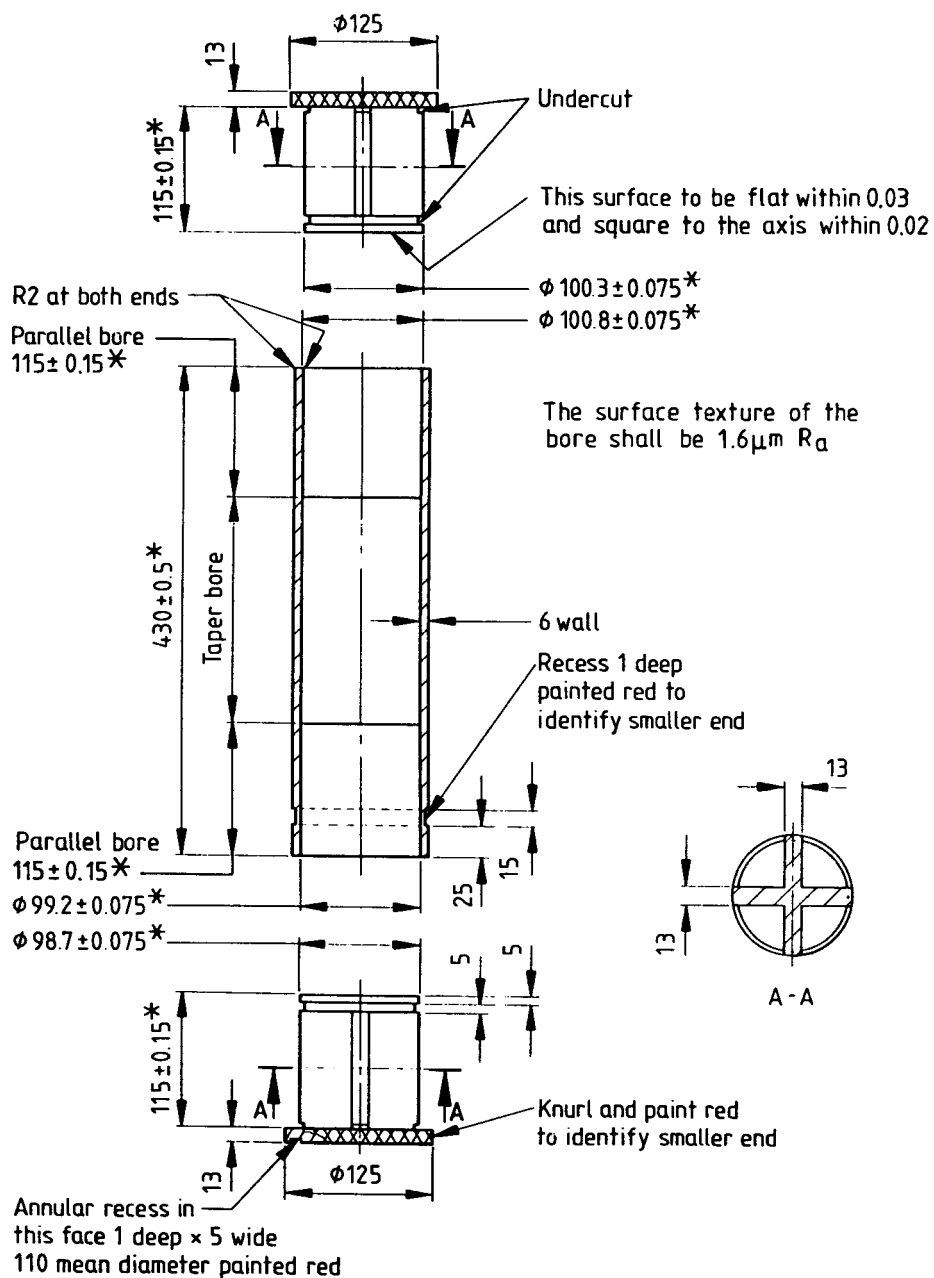

\*See 4.2.2 of BS 1924-1:1990.

All dimensions are in millimetres.

NOTE This design has been found satisfactory, but alternative designs may be employed, provided that the essential requirements are fulfilled.

**Figure 19 — Tapered cylindrical mould with plugs for preparation of specimens for the compressive strength test (medium-grained materials)**

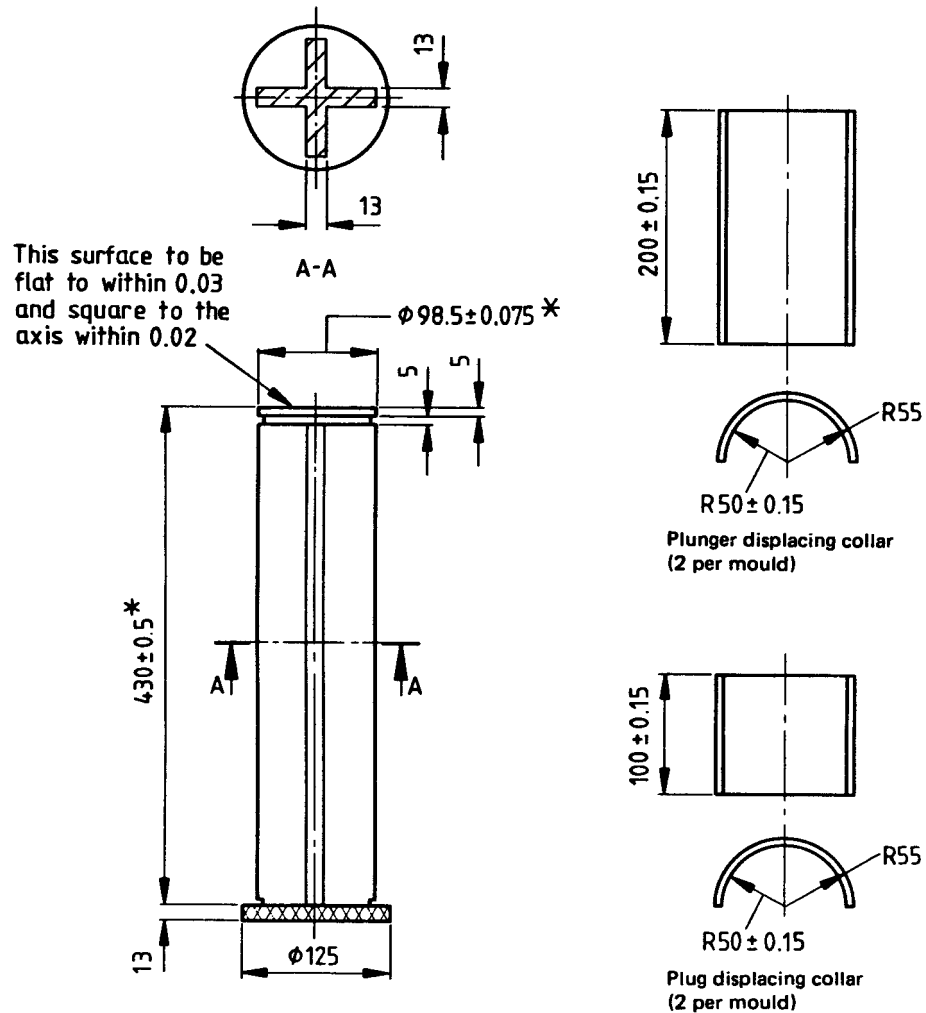

\*See 4.2.2 of BS 1924-1:1990.

All dimensions are in millimetres.

NOTE This design has been found satisfactory, but alternative designs may be employed, provided that the essential requirements are fulfilled.

**Figure 20 — Plunger and displacing collar for use with tapered cylindrical mould of Figure 19**

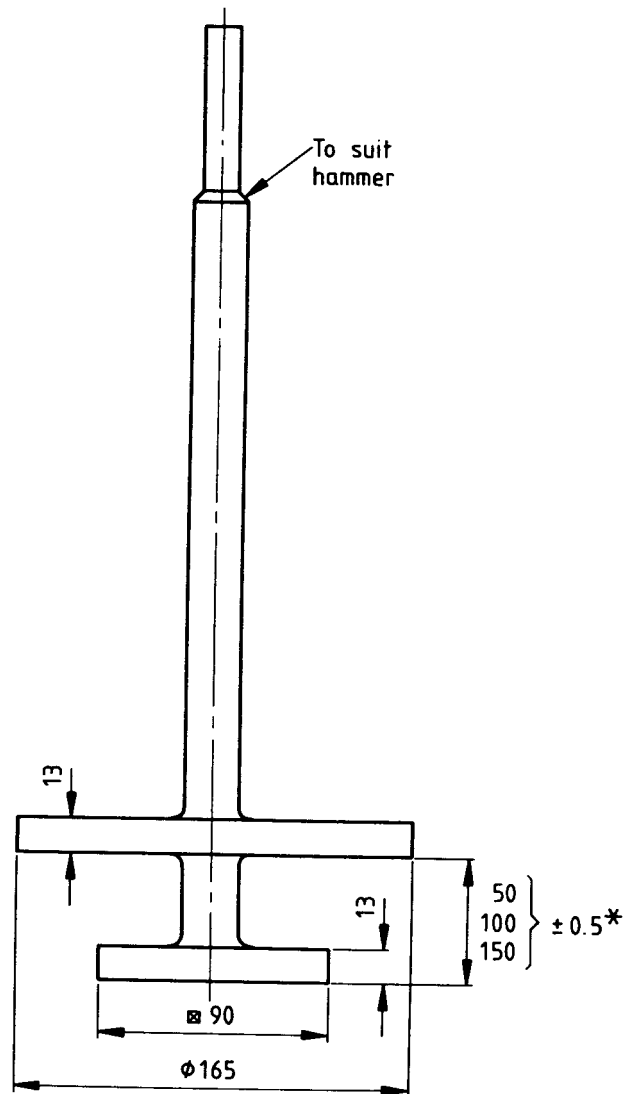

\*See 4.2.2 of BS 1924-1:1990.

All dimensions are in millimetres.

NOTE This design has been found satisfactory, but alternative designs may be employed, provided that the essential requirements are fulfilled.

**Figure 21 — Tamper with spacing collar, for use with a vibrating hammer, for preparation of cubic specimens made up to a predetermined dry density for the compressive strength test**



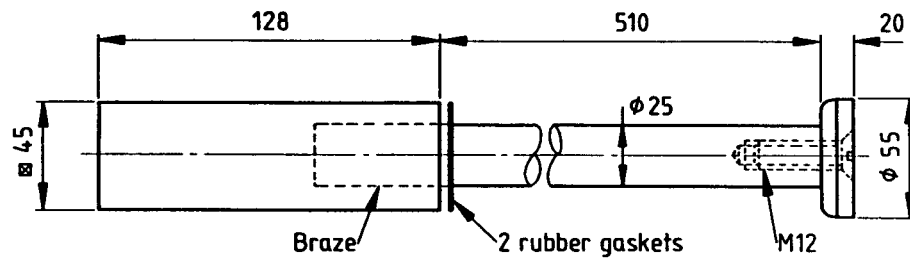

Rammer total mass 4.5 kg

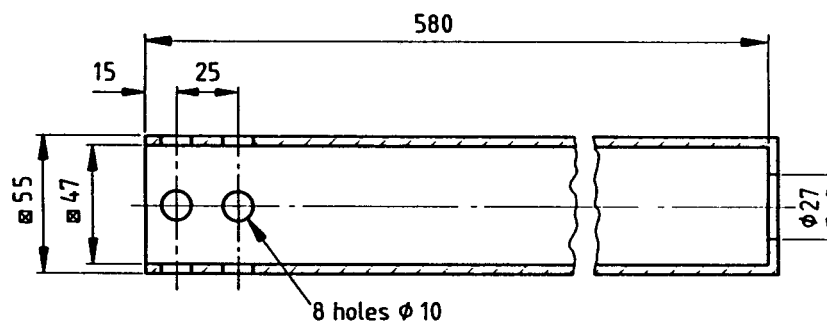

Guide length of travel of rammer 450

All dimensions are in millimetres.

\*See 4.2.2 of BS 1924-1:1990.

NOTE This design has been found satisfactory, but alternative designs may be employed, provided that the essential requirements are fulfilled.

**Figure 22 — Rammer for preparation of cubic specimens compacted to a constant compactive effort for the compressive strength test**

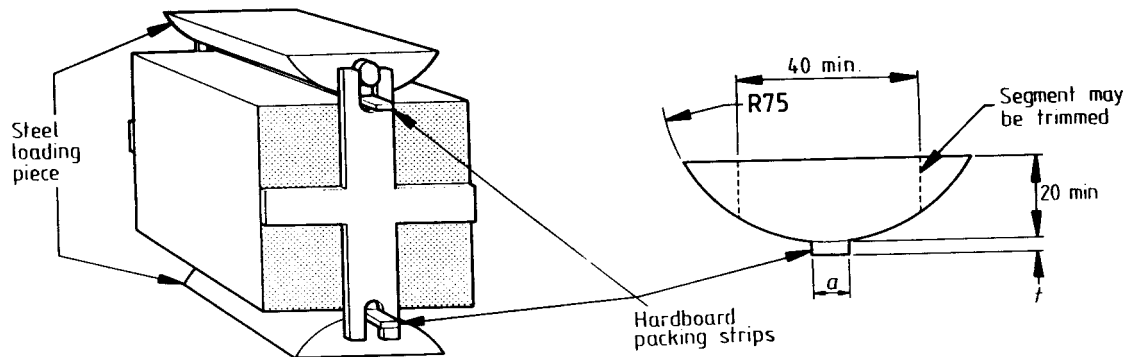

All dimensions are in millimetres.  
See 4.2.2 of BS 1924-1:1990.

(a) Apparatus A for splitting cubes and prismatic specimens

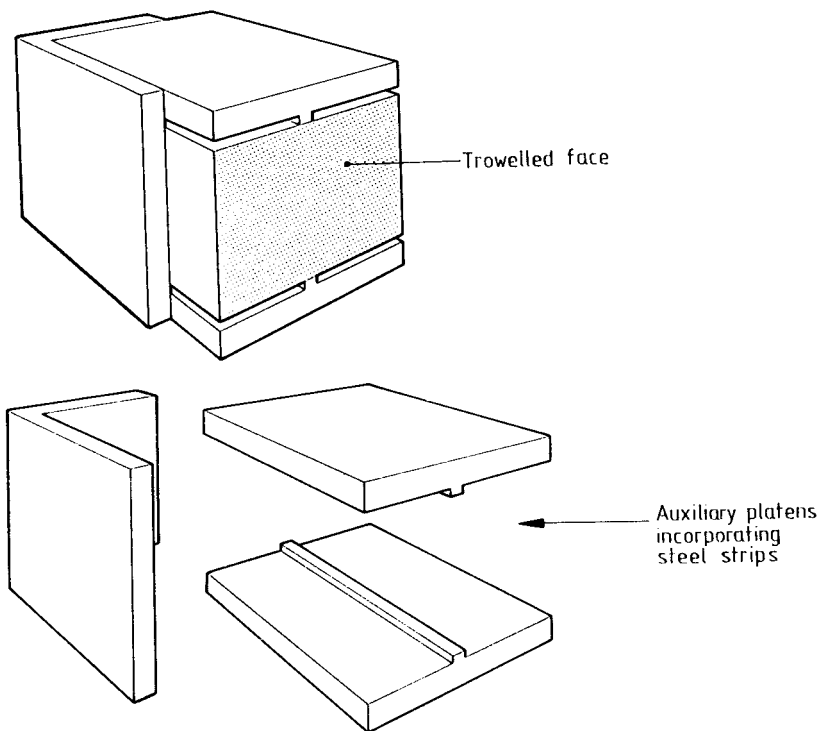

(b) Apparatus B for splitting cubes and prismatic specimens

**Figure 23 — Suitable jigs for the tensile splitting test**

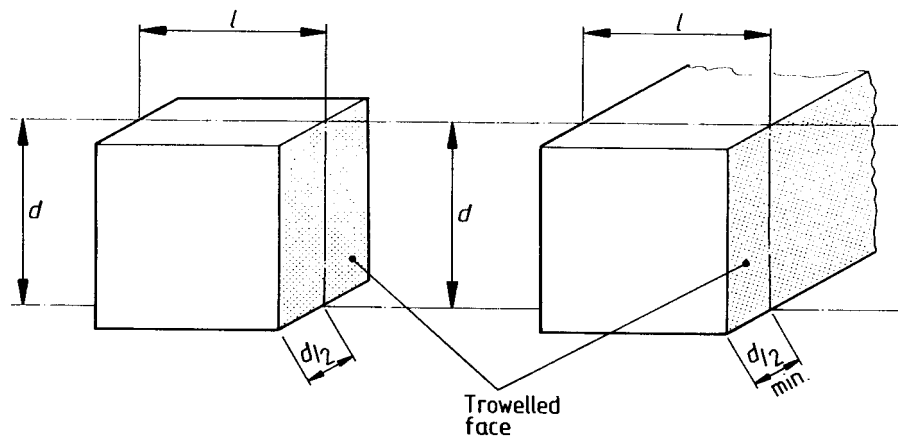
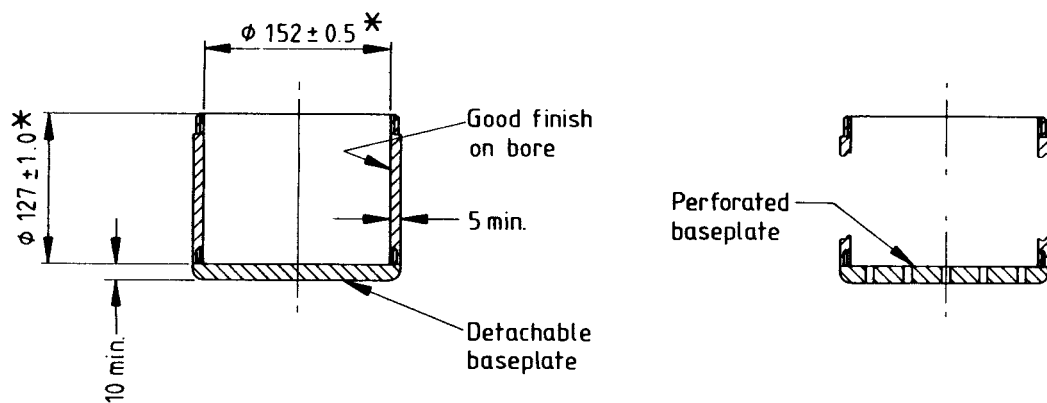

Figure 24 — Plane of loading



All dimensions are in millimetres.

\*See 4.2.2 of BS 1924-1:1990.

Figure 25 — Cylindrical mould for the determination of the California Bearing Ratio

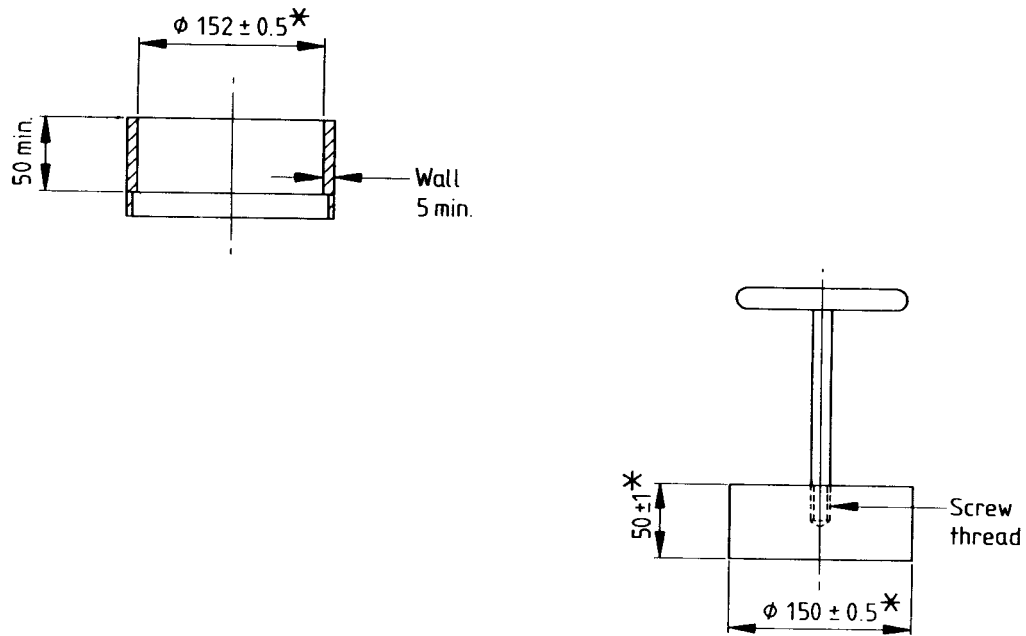

All dimensions are in millimetres.

\*See 4.2.2 of BS 1924-1:1990.

**Figure 26 — Plug and collar for use with the cylindrical mould for the determination of the California Bearing Ratio**

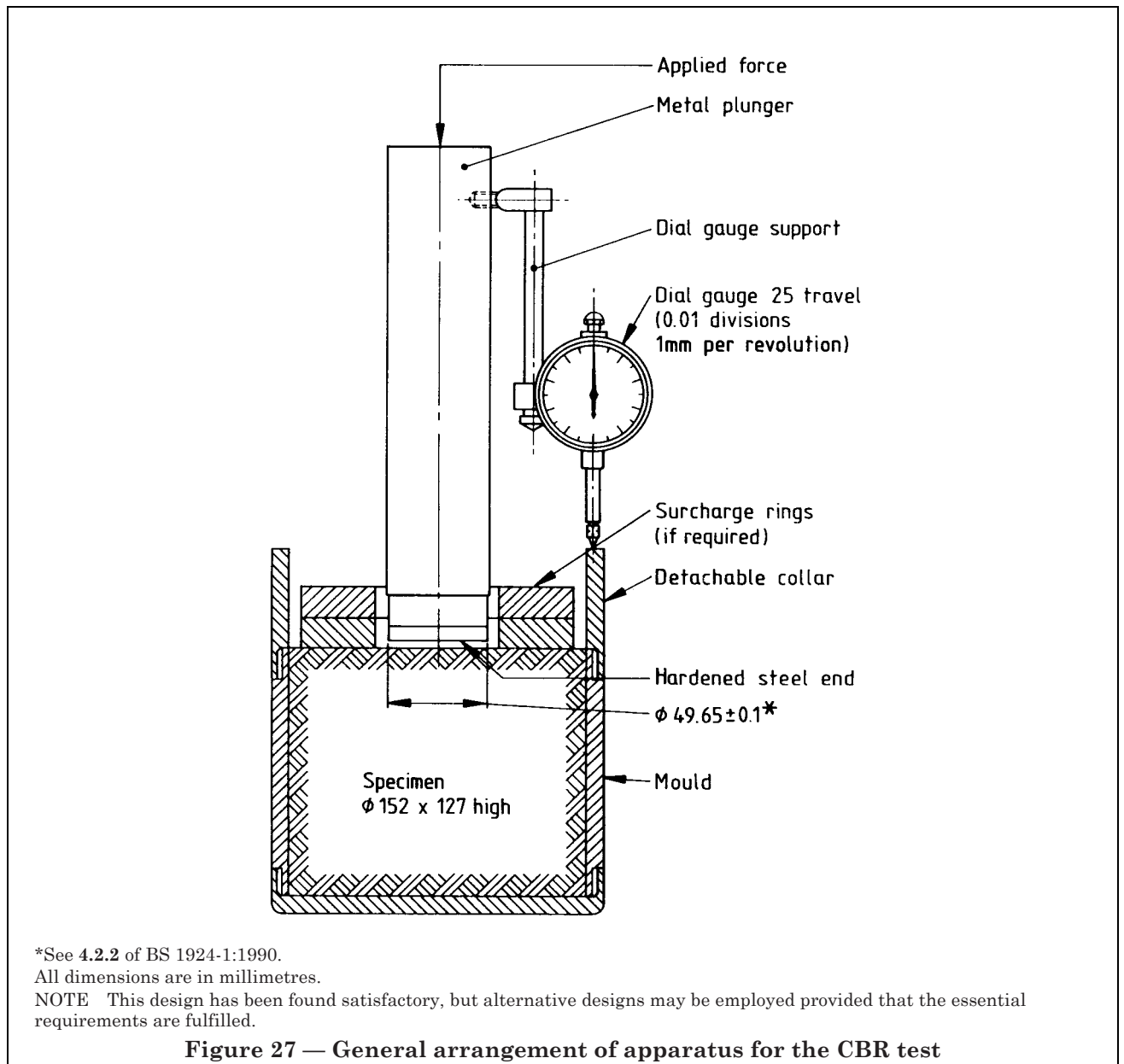

**Figure 27 — General arrangement of apparatus for the CBR test**

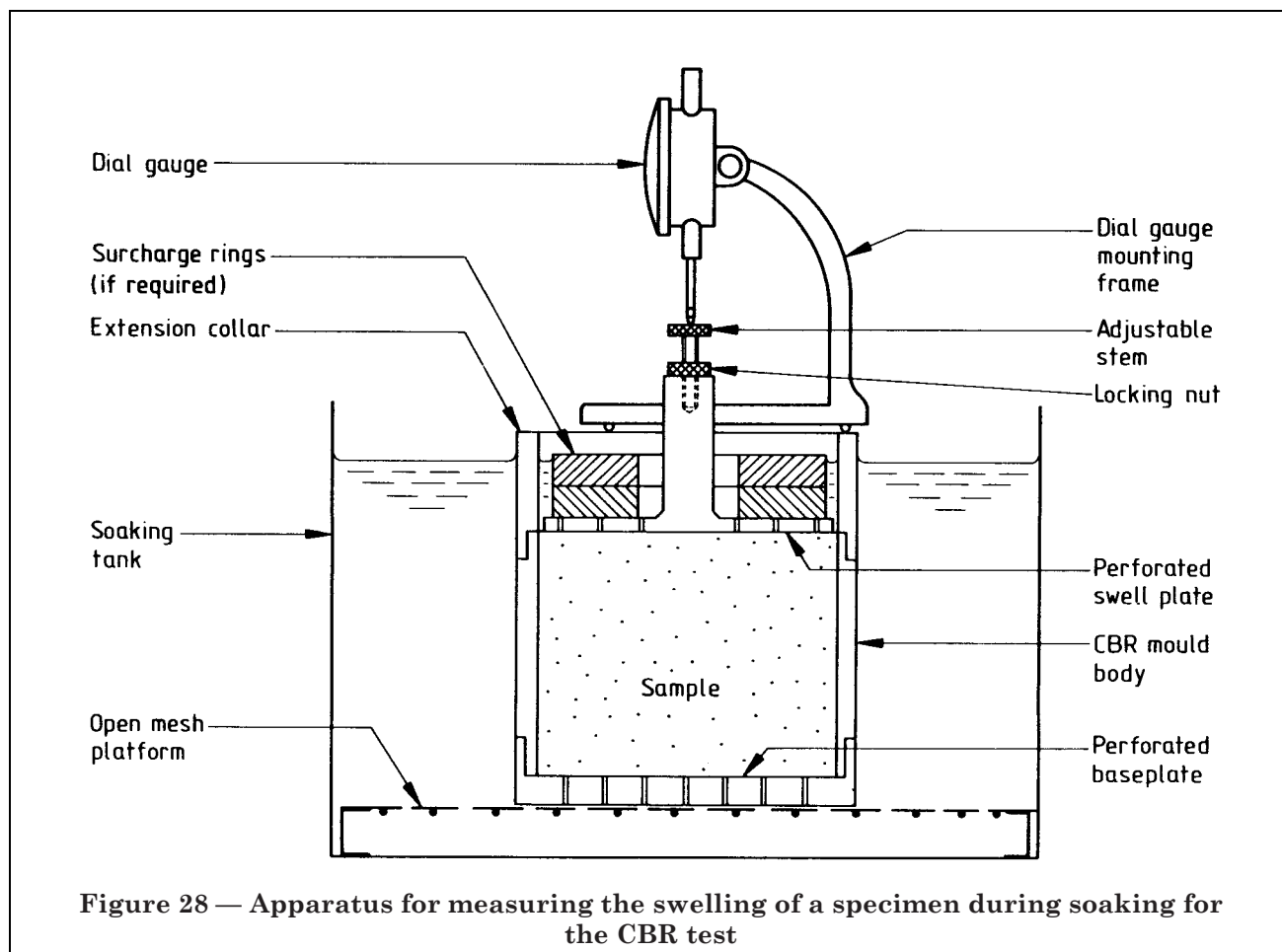

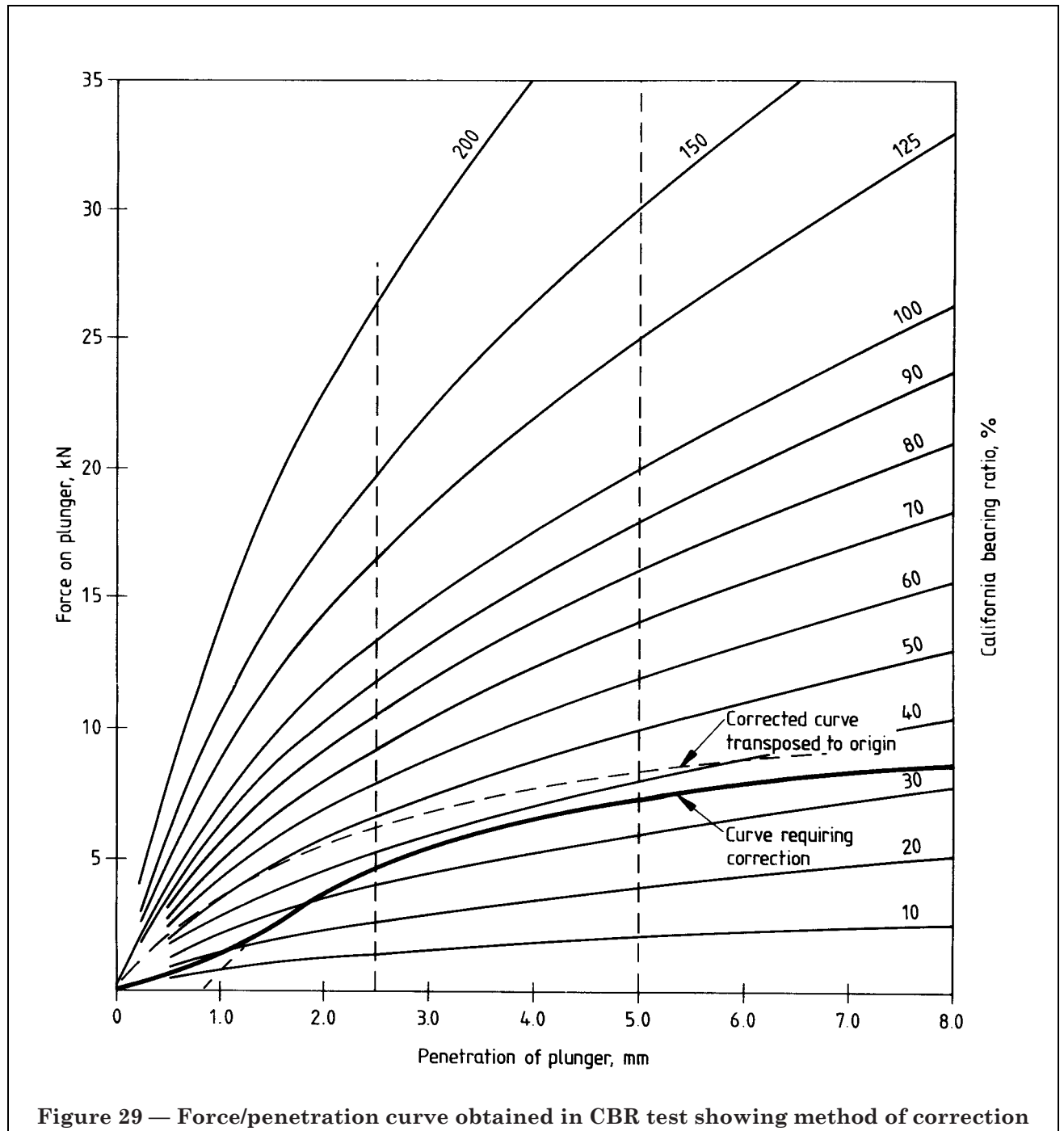

Figure 29 — Force/penetration curve obtained in CBR test showing method of correction

## Appendix A Typical data and calculation forms

This appendix gives the following test sheets as examples only; other suitable forms may be used.

Form	Title
A	Determination of the moisture content by drying
B	Determination of the plastic limit
C	Determination of the liquid limit
D	Determination of the degree of pulverization
E	Determination of the dry density/moisture content relation by the 2.5 kg/4.5 kg rammer method
F	Determination of the dry density/moisture content relation by the vibrating hammer method
G	Suitable test sheet with worked example for the determination of vibrated density and moisture content
H	Determination of the in-situ density sand-replacement method
I	Determination of the in-situ density core-cutter method
J	Determination of the in-situ density immersion-in-water method
K	Determination of the in-situ density water-displacement method
L	Determination of the compressive strength
M	Determination of the effect of immersion in water on compressive strength
N	Determination of the CBR value
O	Determination of the cement content of cement-stabilized materials
P	Determination of the lime content of lime-stabilized materials
Q	Determination of the initial consumption of lime

Form A. Determination of the moisture content by drying	
Laboratory:	Method used:
Operator:	Material:
Job:	Stabilizer:
Site:	Stabilizer content:
Date:	
Sample No.	
Mass of wet material + container ( $m_2$ )	g
Mass of dried material + container ( $m_3$ )	g
Mass of container ( $m_1$ )	g
Mass of moisture ( $m_2 - m_3$ )	g
Mass of dried material ( $m_3 - m_1$ )	g
Moisture content $w = \frac{100(m_2 - m_3)}{(m_3 - m_1)}$ %	



<b>Form B. Determination of the plastic limit</b>	
Laboratory:	Date:
Operator:	Material:
Job:	Stabilizer:
Site:	Stabilizer content:
	Age at test:
<i>Plastic limit of the unstabilized material</i>	
Test No.	
Container No.	
Mass of wet material + container (g)	
Mass of dry material + container (g)	
Mass of container (g)	
Mass of dry material (g)	
Moisture content (%)	
<i>Plastic limit of the stabilized material</i>	
Test No.	
Container No.	
Mass of wet material + container (g)	
Mass of dry material + container (g)	
Mass of container (g)	
Mass of dry material (g)	
Moisture content (%)	
PLASTIC LIMIT OF THE UNSTABILIZED MATERIAL ..... %	
PLASTIC LIMIT OF THE STABILIZED MATERIAL ..... %	

**Form C. Determination of the liquid limit**

Laboratory: Operator: Job: Site:	Date: Material: Stabilizer: Stabilizer content: Age at test:
---	--

Test No.	1	2	3	4
Initial dial gauge reading (mm)				
Final dial gauge reading (mm)				
Average penetration (mm)				
Container No.				
Mass of wet material + container (g)				
Mass of dry material + container (g)				
Mass of container (g)				
Mass of moisture (g)				
Mass of dry material (g)				
Moisture content (%)				

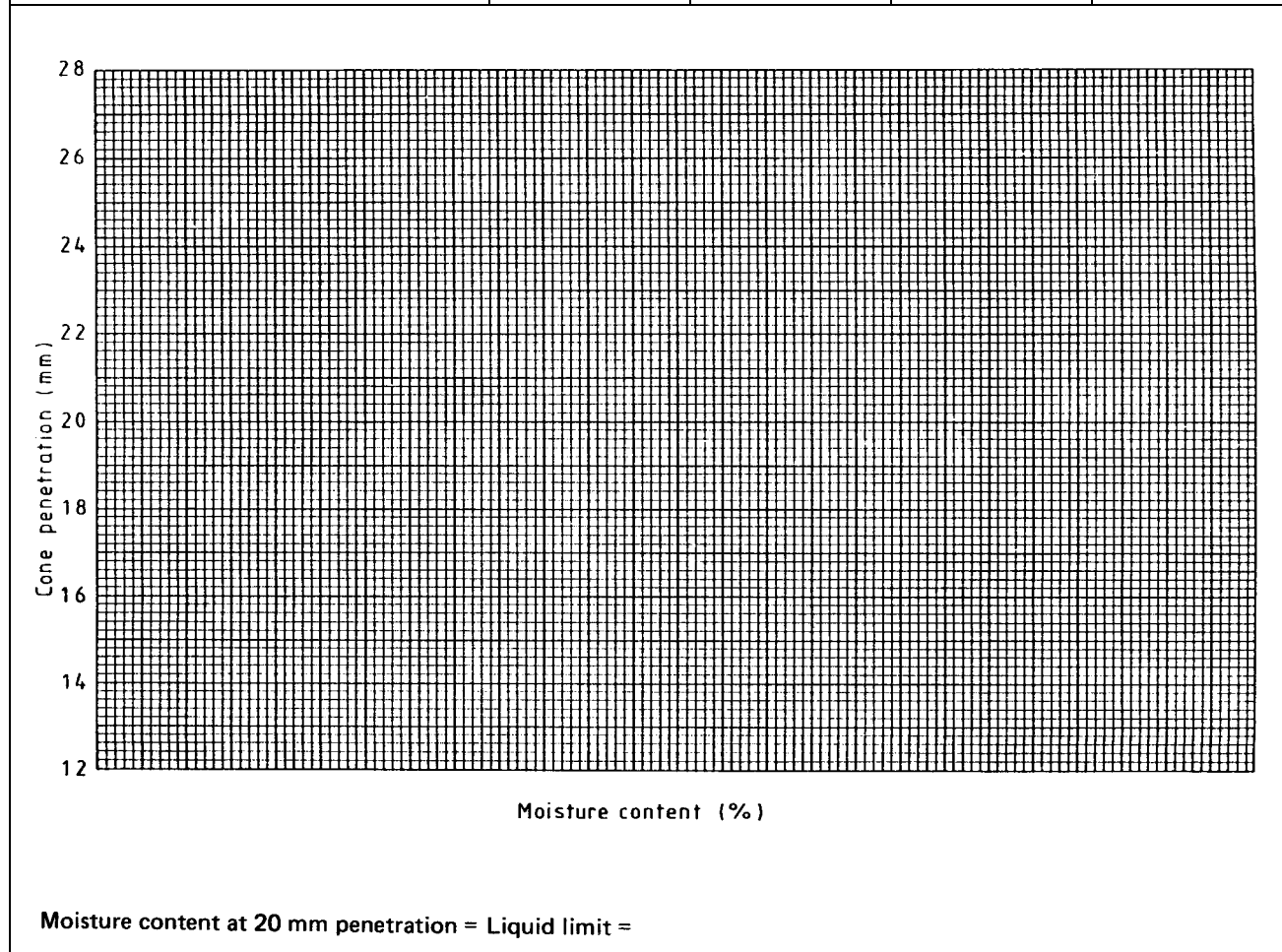

Form D. Determination of the degree of pulverization				
Laboratory:	Date:			
Operator:	Material:			
Job:	Stabilizer:			
Site:	Stabilizer content:			
Sample No.				
Total mass of the sample ( $m_1$ )	g			
Mass of unbroken material retained on sieve ( $m_2$ )	g			
Mass of material finally retained on sieve ( $m_3$ )	g			
Degree of pulverization $P = \frac{100(m_1 - m_2)}{(m_1 - m_3)}$	%			

**Form E. Determination of the dry density/moisture content relation by the 2.5 kg\*/4.5 kg\* rammer method**

Laboratory: Rammer used: 2.5 kg\*/4.5 kg\*  
 Operator: Mould used: IL\*/CBR\*  
 Material: Retained on 20 mm\*/37.5 mm\* sieve  
 Job: Stabilizer:  
 Site: Stabilizer content:

\*Delete as appropriate.

Test Portion No.									
Mass of mould + base + specimen ( $m_2$ )	g								
Mass of mould + base ( $m_1$ )	g								
Mass of compacted specimen ( $m_2 - m_1$ )	g								
Bulk density $\rho = \frac{m_2 - m_1}{v^\dagger}$	Mg/m <sup>3</sup>								
Moisture content ( $w$ )	%								
Dry density $\rho_d = \frac{100\rho}{100 + w}$	Mg/m <sup>3</sup>								

†  $v = 1000$  for 1 L mould;  $v = 2305$  for CBR mould.

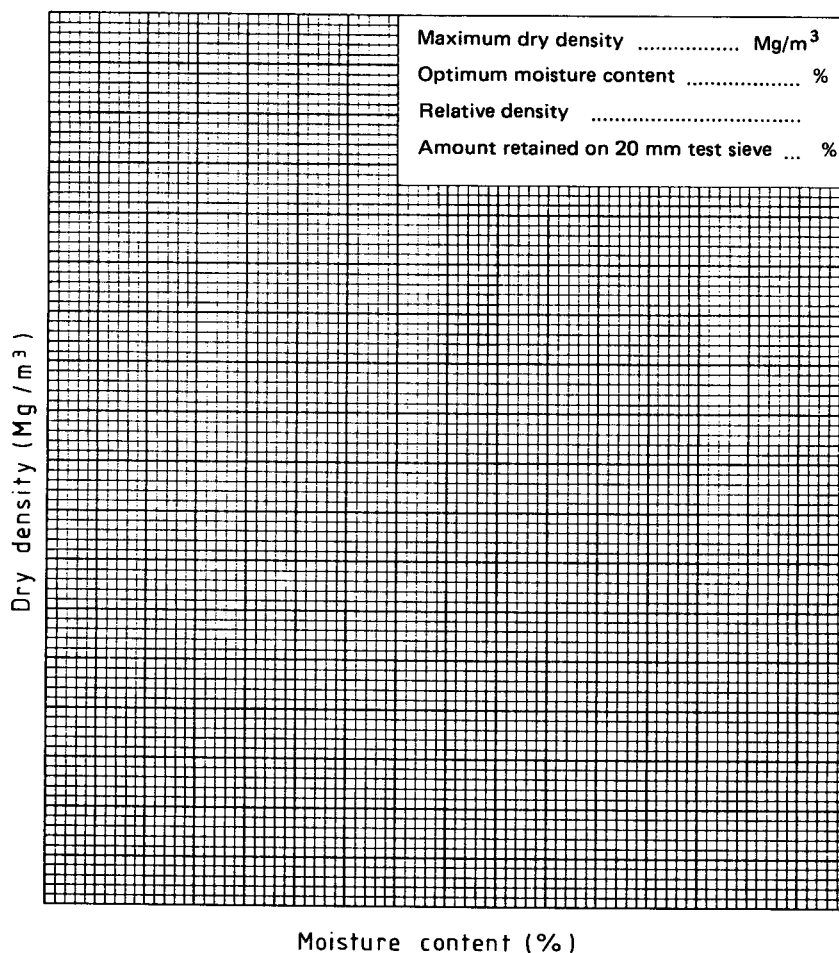

**Form F. Determination of the dry density/moisture content relation by the vibrating hammer method**

Laboratory:	Date:
Operator:	Material:
Job:	Retained on 37.5 mm test sieve:
Site:	Stabilizer:
	Stabilizer content:

Test Portion No.	
Mass of mould + base + collar + specimen ( $m_2$ )	g
Mass of mould + base + collar ( $m_1$ )	g
Mass of compacted specimen ( $m_2 - m_1$ )	g
Height of specimen ( $h$ )	mm
Bulk density $\rho = \frac{m_2 - m_1}{1815h}$	Mg/m <sup>3</sup>
Moisture content ( $w$ )	%
Dry density $\rho_d = \frac{100\rho}{100 + w}$	Mg/m <sup>3</sup>

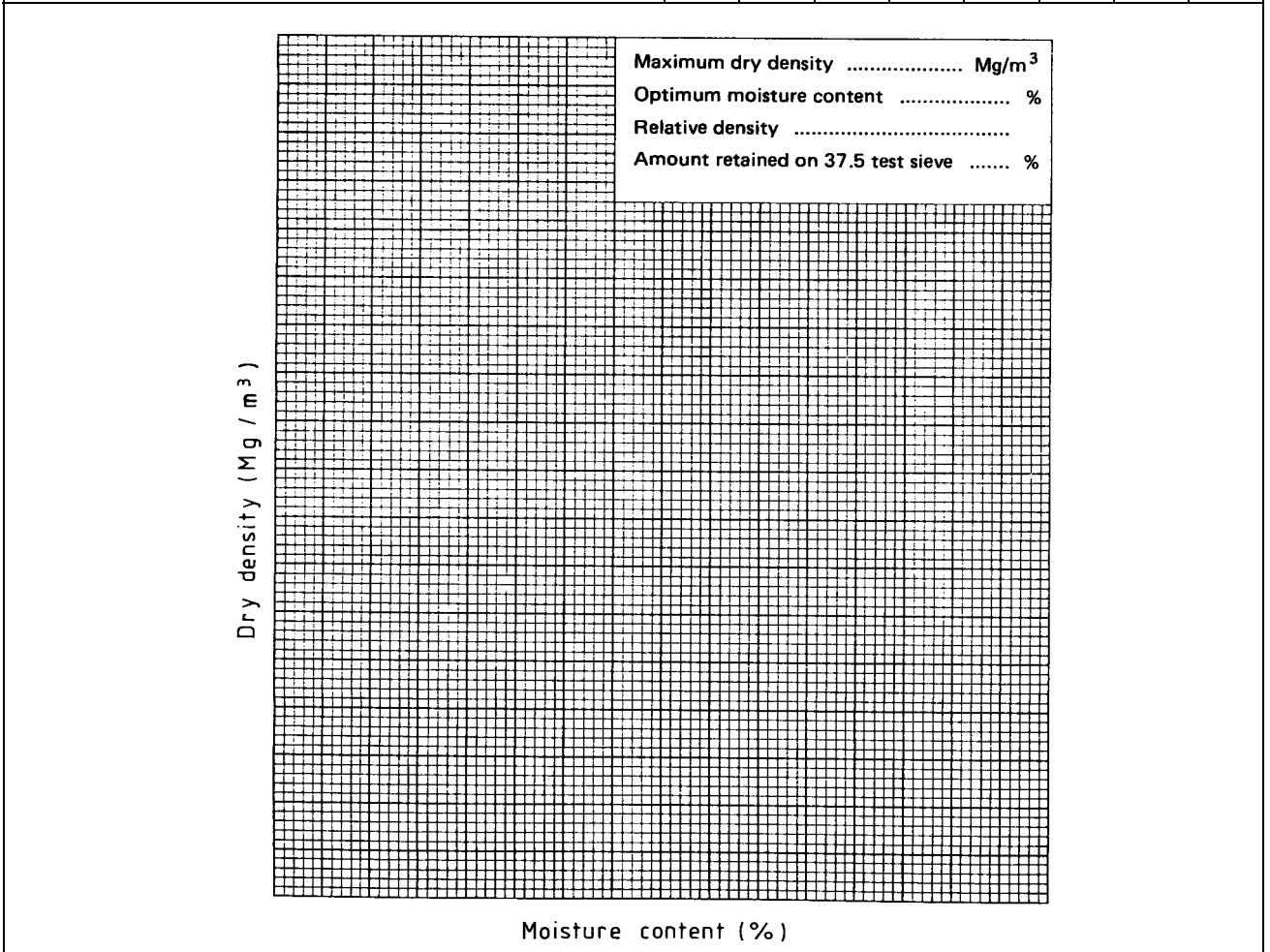

Form G. Suitable that sheet with worked example for the determination of vibrated density and moisture content					
Sample reference:					
Operator:					
Date:					
Calculations	Observations	Precision			Mean
$w$	Initial moisture content (%)	Nearest 0.1	6.0	6.0	6.0
$x$	Mass storage container and sample (g)	Nearest 1	2996	2998	—
$y$	Mass of storage container empty (g)	Nearest 1	303	301	—
$m_1 = x - y$	Initial wet mass of test portion (g)	Nearest 1	2693	2697	—
$m_2 = \frac{100m_1}{w + 100}$	Initial dry mass of test portion (g)	Nearest 1	2541	2544	—
$a$	Cross-sectional area mould (mm <sup>2</sup> )	Nearest 10	17980	17680	—
$b$	Mass of portion at residual moisture content (g)	Nearest 1	2664	2673	—
$c$	Mass of oven-dry portion (g)	Nearest 1	2538	2540	—
$d = b - c$	Mass of residual moisture (g)	Nearest 1	126	133	—
$e$	Depth gauge reading on empty mould (mm)	Nearest 0.1	278.7	278.7	—
$f$	Depth gauge reading on compacted portion (mm)	Nearest 0.1	211.1	210.3	—
$h = e - f$	Height of compacted portion (mm)	Nearest 0.1	67.6	68.4	—
$p = \frac{10m_2(100 + W_R)}{a \times h}$	Vibrated bulk density (Mg/m <sup>3</sup> )	Nearest 0.01	2.23	2.21	2220
$p_d = \frac{10^3 m_2}{a \times h}$	Vibrated dry density (Mg/m <sup>3</sup> )	Nearest 0.01	2.13	2.10	2120
$W_R = \frac{100d}{c}$	Residual moisture content (%)	Nearest 0.1	5.0	5.2	5.1

Form H. Determination of the in-situ density sand-replacement method					
Laboratory:	Pouring cylinder: Large/Small				
Operator:	Material:				
Job:	Stabilizer:				
Site:	Stabilizer content:				
Date:					
Calibration					
Mean mass of sand in cone (of pouring cylinder) ( $m_2$ )					g
Volume of calibrating container ( $V$ )					mL
Mass of sand (+ cylinder) before pouring ( $m_1$ )					g
Mean mass of sand (+ cylinder) after pouring ( $m_3$ )					g
Mass of sand to fill calibrating container ( $m_3 = m_1 - m_3 - m_2$ )					g
Bulk density of sand $\rho_s = \frac{m_3}{V}$					Mg/m <sup>3</sup>
Sample No.					
Mass of wet material from hole ( $m_w$ )	g				
Mass of sand (+ cylinder) before pouring ( $m_1$ )	g				
Mass of sand (+ cylinder) after pouring ( $m_4$ )	g				
Mass of sand in hole ( $m_b = m_1 - m_4 - m_2$ )	g				
Ratio $\frac{m_w}{m_b}$					
Bulk density $\rho = \frac{m_w}{m_b} \times \rho_s$	Mg/m <sup>3</sup>				
Moisture content container No.					
Moisture content ( $w$ )	%				
Dry density $\rho_d = \frac{100\rho}{100 + w}$	Mg/m <sup>3</sup>				

Form I. Determination of the in-situ density core-cutter method					
Laboratory:	Date:				
Operator:	Material:				
Job:	Stabilizer:				
Site:	Stabilizer content:				
Length of core-cutter:    mm	Volume of core-cutter:				mL
Sample number					
Mass of core cutter + wet material ( $m_s$ )	g				
Mass of core cutter ( $m_c$ )	g				
Mass of wet material ( $m_s - m_c$ )	g				
Bulk density $\rho = \frac{m_s - m_c}{V_c}$	Mg/m <sup>3</sup>				
Moisture content container No.					
Moisture content ( $w$ )	%				
Dry density $\rho_d = \frac{100\rho}{100 + w}$	Mg/m <sup>3</sup>				



Form J. Determination of the in-situ density immersion in water method						
Laboratory:	Date:					
Operator:	Material:					
Job:	Stabilizer:					
Site:	Stabilizer content:					
Density of wax used ( $\rho_p$ )	g/mL					
Sample No.						
Mass of stabilized sample ( $m_s$ )	g					
<sup>a</sup> Mass of soaked specimen ( $m_a$ )	g					
<sup>a</sup> Apparent mass of specimen suspended in water ( $m_b$ )	g					
<sup>a</sup> Mass of surface dry specimen after suspension in water ( $m_c$ )	g					
<sup>a</sup> Volume of specimen ( $V_s = m_a - m_b$ )	mL					
<sup>a</sup> Mass of specimen after oven drying ( $m_d$ )	g					
<sup>a</sup> Mass of specimen after filling air voids ( $m_f$ )	g					
<sup>a</sup> Mass of specimen after waxing ( $m_w$ )	g					
<sup>a</sup> Mass of wax ( $m = m_w - m_f$ )	g					
<sup>a</sup> Apparent mass of waxed specimen suspended in water ( $m_g$ )	g					
<sup>a</sup> Volume of specimen $V_s = (m_w - m_g) - \frac{m}{\rho_p}$	mL					
Bulk density $\rho = \frac{m_s}{V_s}$	Mg/m <sup>3</sup>					
<sup>a</sup> Dry density $\rho_d = \frac{m_d}{V_s}$	Mg/m <sup>3</sup>					
Moisture content container No.						
<sup>a</sup> Moisture content ( $w$ )	%					
<sup>a</sup> Dry density (unwaxed) $\rho_d = \frac{100}{(100 + w)} \times \frac{m_a}{V_s}$	Mg/m <sup>3</sup>					
<sup>a</sup> Dry density (waxed) $\rho_d = \frac{100\rho}{100 + w}$	Mg/m <sup>3</sup>					
<sup>a</sup> Delete the words or symbols that do not apply.						

Form K. Determination of the in-situ density water-displacement method					
Laboratory:	Date:				
Operator:	Material:				
Job:	Stabilizer:				
Site:	Stabilizer content:				
Density of wax used ( $\rho_p$ ):	g/mL				
Sample No.					
Mass of stabilized soil sample ( $m_s$ )	g				
<sup>a</sup> Mass of soaked specimen ( $m_a$ )	g				
<sup>a</sup> Mass of surface dry specimen after immersion in water ( $m_c$ )	g				
<sup>a</sup> Mass of specimen after oven drying ( $m_d$ )	g				
<sup>a</sup> Mass of specimen after filling air voids ( $m_f$ )	g				
<sup>a</sup> Mass of specimen after waxing ( $m_w$ )	g				
<sup>a</sup> Mass of wax ( $m = m_w - m_f$ )	g				
Mass of receiver + displaced water ( $m_2$ )	g				
Mass of receiver empty ( $m_1$ )	g				
<sup>a</sup> Volume of specimen (unwaxed) ( $V_s = m_2 - m_1$ )	mL				
<sup>a</sup> Volume of specimen (waxed) $V_s = m_2 - m_1 - \frac{m}{\rho_p}$	mL				
Bulk density $\rho = \frac{m_s}{V_s}$	Mg/m <sup>3</sup>				
<sup>a</sup> density $\rho_d = \frac{m_d}{V_s}$	Mg/m <sup>3</sup>				
Moisture content container No.					
<sup>a</sup> Moisture content ( $w$ )	%				
<sup>a</sup> Dry density (unwaxed) $\rho_d = \frac{100}{(100 + w)} \times \frac{m_c}{V_s}$	Mg/m <sup>3</sup>				
<sup>a</sup> Dry density (waxed) $\rho_d = \frac{100\rho}{100 + w}$	Mg/m <sup>3</sup>				
<sup>a</sup> Delete the words or symbols that do not apply.					

Form L. Determination of the compressive strength						
Laboratory:	Material:					
Operator:	Stabilizer:					
Job:	Specimen size:					
Site:	Specimen shape:					
Specimen No.						
Method of preparation						
Dimensions of specimen	mm					
Stabilizer content	%					
Date made						
Date tested						
Mass of specimen as prepared ( $m_2$ )	g					
Mass of specimen + wax or curing tin before curing ( $m_3$ )	g					
Mass of specimen + wax or curing tin after curing ( $m_4$ )	g					
Loss of mass during curing ( $m_3 - m_4$ )	g					
<sup>a</sup> Length of cylindrical specimen ( $L$ )	mm					
<sup>a</sup> Mass of specimen after immersion ( $m_s$ )	g					
Maximum test load ( $P$ )	N					
Maximum compressive strength ( $p$ )	MPa					
Moisture content container No.						
<sup>a</sup> Moisture content ( $w$ )	%					
<sup>a</sup> Dry density ( $\rho_d$ )	Mg/m <sup>3</sup>					
<sup>a</sup> Delete the words or symbols that do not apply.						

<b>Form M. Determination of the effect of immersion in water on compressive strength</b>	
Laboratory:	Material:
Operator:	Stabilizer:
Job:	Specimen size:
Site:	Specimen shape:
<i>Control specimens</i>	
Specimen No.	
Date made	
Date tested	
Compressive strength (MPa)	
Moisture content (%)	
Dry density (Mg/m <sup>3</sup> )	
Mean compressive strength ( $P_c$ ) MPa	
<i>Immersed specimens</i>	
Specimen No.	
Date made	
Date tested	
Initial dimensions (mm)	
Dimensions after soaking (mm)	
Compressive strength (MPa)	
Moisture content (%)	
Dry density (Mg/m <sup>3</sup> )	
Mean compressive strength ( $P_i$ ) MPa	
RESISTANCE TO IMMERSION ( $R_i = 100P_i/P_c$ ) %	

Form N. Determination of the CBR value	
Laboratory:	Material:
Operator:	Stabilizer:
Job:	Starting date:
Site:	Date tested:
Specimen No.	
Method of preparation	
Mould No.	
Mass of stabilized material ( $m_1$ )	g
Mass of mould + baseplate ( $m_2$ )	g
Mass of mould + baseplate + material ( $m_3$ )	g
Mass of material ( $m_3 - m_2$ )	g
<sup>a</sup> Mass of assembly after soaking ( $m_4$ )	g
<sup>a</sup> Mass of material after soaking ( $m_4 - m_2$ )	g
Maximum CBR from plotting chart	%
Bulk density (unsoaked) ( $\rho$ )	Mg/m <sup>3</sup>
Moisture content container No.	
Moisture content ( $w$ )	%
<sup>a</sup> Dry density (unsoaked) ( $\rho_d$ )	Mg/m <sup>3</sup>
<sup>a</sup> Dry density (soaked) ( $\rho_d$ )	Mg/m <sup>3</sup>
<sup>a</sup> Delete the words which do not apply.	

**Form N. Determination of the CBR value (concluded)**

Tin No.	Moisture content	Mean moisture content

Bearing value at  
 2.5 mm      5.0 mm  
 Top                      %  
 Bottom                      %

Penetration of plunger mm	Force on plunger		Penetration of plunger mm	Force on plunger		Penetration of plunger mm	Force on plunger	
	Top kN	Bottom kN		Top kN	Bottom kN		Top kN	Bottom kN
0.25			2.75			5.25		
0.50			3.00			5.50		
0.75			3.25			5.75		
1.00			3.50			6.00		
1.25			3.75			6.25		
1.50			4.00			6.50		
1.75			4.25			6.75		
2.00			4.50			7.00		
2.25			4.75			7.25		
2.50			5.00			7.50		

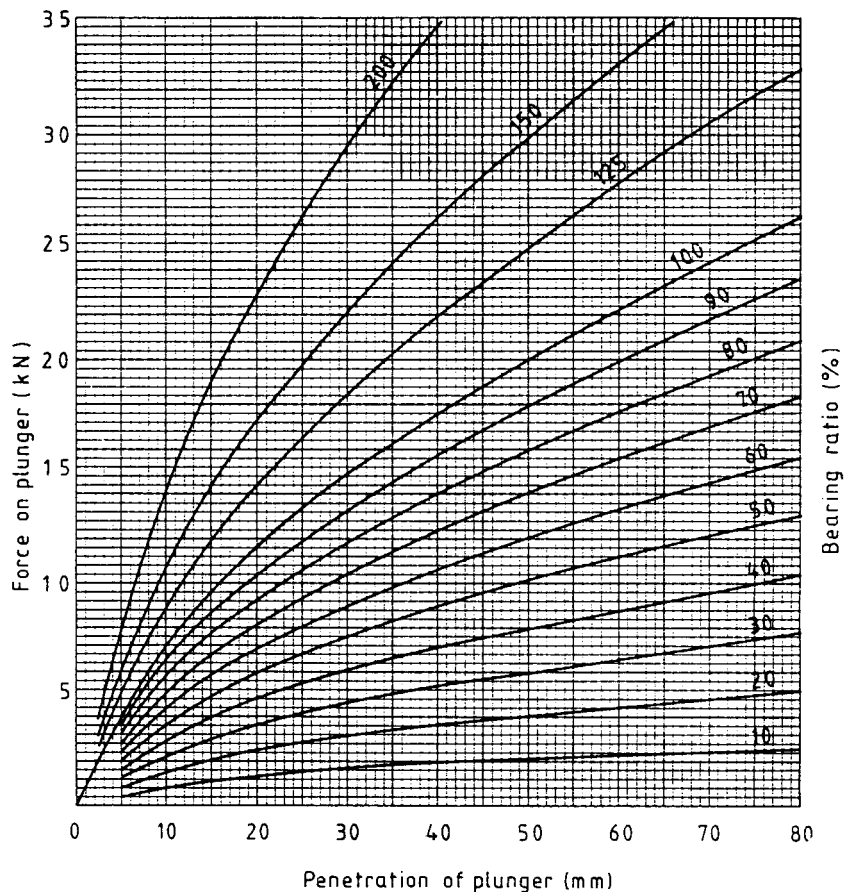

<b>Form O. Determination of the cement content of cement-stabilized materials</b>	
Laboratory:	Material:
Operator:	Site:
Job:	Date:
<i>Standardization of the EDTA solution</i>	
Mass of calcium carbonate used (C)	(g)
Concentration of CaO in standard solution ( $h = C/1.7848$ )	(g/L)
Mean volume of EDTA solution used (t)	(mL)
CaO equivalent (E) of EDTA solution ( $E = 25h/t$ )	(mg/L)
<i>Determination of the cement content</i>	
Sample No.	
Description of sample <sup>a</sup>	
Weighing bottle No.	
Mass of bottle + oven-dry sample	g
Mass of weighing bottle	g
Mass of oven-dry sample ( $m$ )	g
Initial burette reading ( $i$ )	mL
Final burette reading ( $f$ )	mL
Volume of EDTA solution titrated ( $V = f - i$ )	mL
CaO content of unstabilized material ( $X = 5 VE/m$ )	%
CaO content of stabilized material ( $Y = 5 VE/m$ )	%
CaO content of cement ( $Z = 5 VE/m$ )	%
Cement content as percentage of the mass of the stabilized material $C_1 = (Y - X)/(Z - X)$	%
Cement content as percentage of the mass of the natural material $C_2 = 100C_1/(100 - C_1)$	%
<sup>a</sup> i.e. unstabilized material, stabilized material or cement	

<b>Form P. Determination of the lime content of lime-stabilized materials</b>	
Laboratory:	Material:
Operator:	Site:
Job:	Date:
<i>Standardization of the EDTA solution</i>	
Mass of calcium carbonate used ( <i>C</i> )	(g)
Concentration of CaO in standard solution ( $h = C/1.7848$ )	(g/L)
Mean volume of EDTA solution used ( <i>t</i> )	(mL)
CaO equivalent ( <i>E</i> ) of EDTA solution ( $E = 25h/t$ )	(mg/L)
<i>Determination of the lime content</i>	
Sample No.	
Description of sample <sup>a</sup>	
Weighing bottle No.	
Mass of bottle + oven-dry sample	g
Mass of weighing bottle	g
Mass of oven-dry sample ( <i>m</i> )	g
Initial burette reading ( <i>i</i> )	mL
Final burette reading ( <i>f</i> )	mL
Volume of EDTA solution titrated ( $V = f - i$ )	mL
CaO content of unstabilized material ( $X = 5 VE/m$ )	%
CaO content of stabilized material ( $Y = 5 VE/m$ )	%
CaO content of lime ( $Z = 5 VE/m$ )	%
Lime content as percentage of the mass of the stabilized material $L_1 = (Y - X)/(Z - X)$	%
Lime content as percentage of the mass of the natural material $L_2 = 100C_1/(100 - C_1)$	%
<sup>a</sup> i.e. unstabilized material, stabilized material or lime	

<b>Form Q. Determination of the initial consumption of lime</b>	
Laboratory:	Material:
Operator:	Site:
Job:	Date:
	<i>Calcium hydroxide</i>
	<i>Lime used in test</i>
pH of saturated solution	
Temperature (°C)	
pH corrected to 25 °C	
Lime content	%
pH value of suspension	
Temperature	°C
pH corrected to 25 °C	



---

## Publications referred to

- BS 12, *Specification for Portland cements.*
- BS 146, *Specification for Portland-blastfurnace cement.*
- BS 427, *Method for Vickers hardness test.*
- BS 812, *Testing aggregates.*
- BS 812-124, *Method for determination of frost-heave.*
- BS 1142, *Specification for fibre building boards.*
- BS 1377, *Methods of test for soils for civil engineering purposes.*
- BS 1377-4, *Compaction-related tests.*
- BS 1377-7, *Shear strength tests (total stress).*
- BS 1377-9, *In situ tests.*
- BS 1610, *Materials testing machines and force verification equipment.*
- BS 1610-1, *Specification for the grading of the forces applied by materials testing machines.*
- BS 1792, *Specification for one-mark volumetric flasks.*
- BS 1797, *Schedule for tables for use in the calibration of volumetric glassware.*
- BS 1806, *Specification for dimensions of toroidal sealing rings ("O"-rings) and their housings (inch series).*
- BS 1881, *Testing concrete.*
- BS 1881-108, *Method for making tests cubes from fresh concrete.*
- BS 1881-115, *Specification for compression testing machines for concrete.*
- BS 1881-117, *Method for determination of tensile splitting strength.*
- BS 1881-124, *Methods for analysis of hardened concrete.*
- BS 1924, *Stabilized materials for civil engineering purposes.*
- BS 1924-1, *General requirements, sampling, sample preparation and tests on materials before stabilization.*
- BS 2000, *Methods of test for petroleum and its products.*
- BS 4027, *Specification for sulphate-resisting Portland cement.*
- BS 4518, *Specification for metric dimensions of toroidal sealing rings ("O"-rings) and their housing.*
- BS 6588, *Specification for Portland pulverized-fuel ash cement.*
- ASTM D2922, *Standard test methods for density of soil and soil aggregates in place by nuclear methods (shallow depth).*
- ASTM D3017, *Standard test methods for moisture content of soil and soil-aggregate in place by nuclear methods (shallow depth).*

---

---

# BSI — British Standards Institution

BSI is the independent national body responsible for preparing British Standards. It presents the UK view on standards in Europe and at the international level. It is incorporated by Royal Charter.

## Revisions

British Standards are updated by amendment or revision. Users of British Standards should make sure that they possess the latest amendments or editions.

It is the constant aim of BSI to improve the quality of our products and services. We would be grateful if anyone finding an inaccuracy or ambiguity while using this British Standard would inform the Secretary of the technical committee responsible, the identity of which can be found on the inside front cover. Tel: 020 8996 9000. Fax: 020 8996 7400.

BSI offers members an individual updating service called PLUS which ensures that subscribers automatically receive the latest editions of standards.

## Buying standards

Orders for all BSI, international and foreign standards publications should be addressed to Customer Services. Tel: 020 8996 9001. Fax: 020 8996 7001.

In response to orders for international standards, it is BSI policy to supply the BSI implementation of those that have been published as British Standards, unless otherwise requested.

## Information on standards

BSI provides a wide range of information on national, European and international standards through its Library and its Technical Help to Exporters Service. Various BSI electronic information services are also available which give details on all its products and services. Contact the Information Centre. Tel: 020 8996 7111. Fax: 020 8996 7048.

Subscribing members of BSI are kept up to date with standards developments and receive substantial discounts on the purchase price of standards. For details of these and other benefits contact Membership Administration. Tel: 020 8996 7002. Fax: 020 8996 7001.

## Copyright

Copyright subsists in all BSI publications. BSI also holds the copyright, in the UK, of the publications of the international standardization bodies. Except as permitted under the Copyright, Designs and Patents Act 1988 no extract may be reproduced, stored in a retrieval system or transmitted in any form or by any means – electronic, photocopying, recording or otherwise – without prior written permission from BSI.

This does not preclude the free use, in the course of implementing the standard, of necessary details such as symbols, and size, type or grade designations. If these details are to be used for any other purpose than implementation then the prior written permission of BSI must be obtained.

If permission is granted, the terms may include royalty payments or a licensing agreement. Details and advice can be obtained from the Copyright Manager. Tel: 020 8996 7070.