

BRITISH STANDARD

Unified screw threads

Part 1: Screw threads with diameters $\frac{1}{4}$ in and larger – Requirements

ICS 21.040.20

Publishing and copyright information

The BSI copyright notice displayed in this document indicates when the document was last issued.

© BSI 2007

ISBN 978 0 580 57926 4

The following BSI references relate to the work on this standard:

Committee reference FME/9

Draft for comment 07/30158490 DC

Publication history

First published June 1949

Second edition, November 1953

Third edition, as Parts 1 and 2, September 1962

Fourth edition, as Part 1, December 2007

Amendments issued since publication

Amd. no.	Date	Text affected
-----------------	-------------	----------------------

Contents

Foreword *iv*

Section 1: General 1

- 1 Scope 1
- 2 Normative references 2
- 3 Terms and definitions and symbols 2
- 4 Profile of unified screw threads 3

Section 2: Standard series 9

- 5 Diameter/pitch combinations 9
- 6 Tolerance classes of external and internal threads 9
- 7 Limits of size, and tolerances, for uncoated threads 9
- 8 Allowances for uncoated threads 10
- 9 Coated threads 11
- 10 Gauges 14
- 11 Designation of unified screw threads 16

Section 3: Special series (UNS) 69

- 12 Diameter/pitch combinations, fractional sizes 69
- 13 Diameter/pitch combinations, decimal sizes 70
- 14 Tolerance classes of external and internal UNS threads 70
- 15 Tolerances and allowances 70
- 16 Coated UNS threads 71
- 17 Designation of UNS threads 71

Annexes

- Annex A (informative) Bases of tolerances and allowances for unified screw threads $\frac{1}{4}$ in and larger 89
- Annex B (informative) Outline guide, and examples, for calculating limits of size of untabulated UNS screw threads 95
- Annex C (informative) Forms of the crest of external threads 101
- Annex D (informative) General symbols 103
- Annex E (informative) Tolerances on pitch and flank angle in relation to tolerance on effective diameter 106
- Annex F (informative) Standard unified thread series, guidance on selection and use 108
- Annex G (informative) Standard unified thread series, information and guidance regarding the tolerance classes 109

Bibliography 111

List of figures

- Figure 1 – Basic profile of unified screw threads 5
- Figure 2 – Design profiles of unified internal and external threads (maximum material condition) 6
- Figure 3 – Limiting profiles for crests of external threads 8
- Figure 4 – Classes of unified screw threads – Effective diameter tolerance zones of finished uncoated threads 12
- Figure 5 – Classes of unified screw threads – Effective diameter tolerance zones of coated threads before and after coating 13
- Figure 6 – Tolerance zones for unified threads, Class 1A external thread and Class 1B internal thread 14
- Figure 7 – Tolerance zones for unified threads, Class 2A external thread and Class 2B internal thread 15
- Figure 8 – Tolerance zones for unified threads, Class 3A external thread and Class 3B internal thread 16

Figure A.1 – Unified screw threads – Nomogram for effective (pitch) diameter tolerances, Class 2A 94

Figure C.1 – Crest profiles on external threads resulting from different production methods 102

Figure D.1 – General symbols 105

List of tables

Table 1 – Unified screw threads, standard series 20

Table 2 – Unified screw threads, standard series – Limits of size 22

Table 3 – Coarse thread series (UNC) – Limits and tolerances for finished uncoated threads – External threads Class 1A 48

Table 4 – Coarse thread series (UNC) – Limits and tolerances for finished uncoated threads – Internal threads Class 1B 49

Table 5 – Coarse thread series (UNC) – Limits and tolerances for finished uncoated threads – External threads Class 2A 50

Table 6 – Coarse thread series (UNC) – Limits and tolerances for finished uncoated threads – Internal threads Class 2B 51

Table 7 – Coarse thread series (UNC) – Limits and tolerances for finished uncoated threads – External threads Class 3A 52

Table 8 – Coarse thread series (UNC) – Limits and tolerances for finished uncoated threads – Internal threads Class 3B 53

Table 9 – Fine thread series (UNF) – Limits and tolerances for finished uncoated threads – External threads Class 1A 54

Table 10 – Fine thread series (UNF) – Limits and tolerances for finished uncoated threads – Internal threads Class 1B 54

Table 11 – Fine thread series (UNF) – Limits and tolerances for finished uncoated threads – External threads Class 2A 55

Table 12 – Fine thread series (UNF) – Limits and tolerances for finished uncoated threads – Internal threads Class 2B 55

Table 13 – Fine thread series (UNF) – Limits and tolerances for finished uncoated threads – External threads Class 3A 56

Table 14 – Fine thread series (UNF) – Limits and tolerances for finished uncoated threads – Internal threads Class 3B 56

Table 15 – Coarse thread series (UNC) – Basic dimensions 57

Table 16 – Fine thread series (UNF) – Basic dimensions 58

Table 17 – Extra fine thread series (UNEF) – Basic dimensions 59

Table 18 – 4-thread series (4 UN) – Basic dimensions 60

Table 19 – 6-thread series (6 UN) – Basic dimensions 61

Table 20 – 8-thread series (8 UN) – Basic dimensions 62

Table 21 – 12-thread series (12 UN) – Basic dimensions 63

Table 22 – 16-thread series (16 UN) – Basic dimensions 64

Table 23 – 20-thread series (20 UN) – Basic dimensions 65

Table 24 – 28-thread series (28 UN) – Basic dimensions 66

Table 25 – 32-thread series (32 UN) – Basic dimensions 67

Table 26 – Thread data for unified thread form 68

Table 27 – Diameter increments for UNS threads 69

Table 28 – Allowances for external threads of special diameter/pitch combinations (UNS threads) Classes 1A and 2A 72

Table 29 – Major diameter tolerances for external threads of special diameter/pitch combinations (UNS threads) 73

Table 30 – Effective and minor diameter tolerances for external threads of special diameter/pitch combinations (UNS threads) Class 1A 74

Table 31 – Effective and minor diameter tolerances for external threads of special diameter/pitch combinations (UNS threads) Class 2A	75
Table 32 – Effective and minor diameter tolerances for external threads of special diameter/pitch combinations (UNS threads) Class 3A	76
Table 33 – Effective diameter tolerances for internal threads of special diameter/pitch combinations (UNS threads) Class 1B	77
Table 34 – Effective diameter tolerances for internal threads of special diameter/pitch combinations (UNS threads) Class 2B	78
Table 35 – Effective diameter tolerances for internal threads of special diameter/pitch combinations (UNS threads) Class 3B	79
Table 36 – Minor diameter tolerances for internal threads of special diameter/pitch combinations (UNS threads)	80
Table 37 – Unified screw threads – Decimal inch diameters with preferred pitches	81
Table 38 – Limits of size for UNS threads having decimal inch basic sizes and preferred pitches	82
Table A.1 – Limits of size of unified threads as given by screw thread tolerance formulae	93
Table D.1 – General symbols	103

Summary of pages

This document comprises a front cover, an inside front cover, pages i to iv, pages 1 to 111 and a back cover.

Foreword

Publishing information

This part of BS 1580 is published by BSI and came into effect on 31 December 2007. It was prepared by Subcommittee SFTSE/1, *Screws and fasteners technical specification committee*, under the authority of Technical Committee FME/9, *Nuts, bolts and accessories*. A list of organizations represented on this committee can be obtained on request to its secretary.

Supersession

This part of BS 1580 supersedes BS 1580: Parts 1 & 2:1962, which is withdrawn.

Relationship with other publications

BS 1580 is now published in two parts:

- *Part 1: Screw threads with diameters $\frac{1}{4}$ in and larger – Requirements*
- *Part 3: Screw threads with diameters below $\frac{1}{4}$ in – Requirements*

This part of BS 1580 is intended for use with BS 919-1 and BS 919-4 which specify the corresponding screw gauges.

Information about this document

This part of BS 1580 has been fully revised to bring it up to date.

The diameter/pitch combinations which are recognized as standard threads in the ISO inch system include the American numbered sizes. A copy of the ISO table of these standard threads (but with the omission of the numbered sizes), is reproduced in Table 1 of this part of BS 1580.

Hazard warnings

WARNING. Attention is drawn to the fact that, with the different screw thread forms available, there is the possibility of a mismatch, which is potentially hazardous. It is the responsibility of the designer of the end product to ensure that this possibility is reduced to a minimum. For further information on mismatches of screw thread systems see PD 6494.

Presentational conventions

The provisions of this standard are presented in roman (i.e. upright) type. Its requirements are expressed in sentences in which the principal auxiliary verb is “shall”.

Commentary, explanation and general informative material is presented in smaller italic type, and does not constitute a normative element.

Contractual and legal considerations

This publication does not purport to include all the necessary provisions of a contract. Users are responsible for its correct application.

Compliance with a British Standard cannot confer immunity from legal obligations.

Section 1: General

1 Scope

This part of BS 1580 specifies limits of sizes, and tolerances, for single-start, clearance-fit unified screw threads, in inch units, with nominal diameters $\frac{1}{4}$ in and above, having the ISO basic profile as specified in BS ISO 68-2:1998.

The part of BS 1580 specifies the following unified thread series as follows:

- a) standard variable pitch series:
 - a coarse thread series (UNC) from $\frac{1}{4}$ in to 4 in nominal diameter;
 - a fine thread series (UNF) from $\frac{1}{4}$ in to $1\frac{1}{2}$ in nominal diameter;
 - an extra fine thread series (UNEF) from $\frac{1}{4}$ in to $1\frac{11}{16}$ in nominal diameter;
- b) standard constant pitch series:
 - a 4-threads per inch series (4 UN) from $2\frac{5}{8}$ in to 6 in nominal diameter;
 - a 6-threads per inch series (6 UN) from $1\frac{7}{16}$ in to 6 in nominal diameter;
 - an 8-threads per inch series (8 UN) from $1\frac{1}{16}$ in to 6 in nominal diameter;
 - a 12-threads per inch series (12 UN) from $\frac{5}{8}$ in to 6 in nominal diameter;
 - a 16-threads per inch series (16 UN) from $\frac{7}{16}$ in to 6 in nominal diameter;
 - a 20-threads per inch series (20 UN) from $\frac{5}{16}$ in to 3 in nominal diameter;
 - a 28-threads per inch series (28 UN) from $\frac{5}{16}$ in to $1\frac{1}{2}$ in nominal diameter;
 - a 32-threads per inch series (32 UN) from $\frac{7}{16}$ in to 1 in nominal diameter;
- c) a special thread series (UNS) with diameter/pitch combinations other than those specified for the standard series.

NOTE 1 A transition fit series and an interference fit series of UNC and UNF threads for application to screwed studs are given in BS 2693-1 and -2, respectively.

NOTE 2 Bases of tolerances and allowances are given in Annex A, guidance for calculating limits of size is given in Annex B, information on crest forms of external threads is given in Annex C, some general symbols are given in Annex D (see 3.2), information on tolerances is given in Annex E, guidance on selection and use of the standard unified thread series is given in Annex F and information and guidance on tolerance classes is given in Annex G.

2 Normative references

The following referenced documents are indispensable for the application of this document. For dated references, only the edition cited applies. For undated references, the latest edition of the referenced document (including any amendments) applies.

BS 6528:1984, *Glossary of terms for cylindrical screw threads*

BS 919-1:2007, *Screw gauge limits and tolerances – Part 1: Specification for gauges for screw threads of unified form*

BS 919-4, *Screw gauge limits and tolerances – Part 4: Limits of size for gauges for screw threads of unified form diameters $\frac{1}{4}$ in and larger*

3 Terms and definitions and symbols

3.1 Terms and definitions

For the purposes of this part of BS 1580 the terms and definitions given in BS 6528:1984 and the following apply.

3.1.1 effective diameter

diameter of the pitch cylinder

NOTE 1 This is the “simple” effective diameter, as distinct from the “virtual” effective diameter (see 3.1.2).

NOTE 2 Also known as pitch diameter.

3.1.2 virtual effective diameter

effective diameter of an imaginary thread of perfect pitch and flank angle, having the full depth of flanks, but clear at the crests and roots, which would just assemble with the actual thread over the prescribed length of engagement

NOTE The “virtual” effective diameter exceeds the simple effective diameter in the case of an external thread, but is less than the simple effective diameter in the case of an internal thread, by an amount corresponding to the combined diametral effects due to any errors in the pitch and/or the flank angles of the thread.

3.2 Symbols

3.2.1 For the purposes of Figures 1 to 8 and Figure C.1a), b), c) and d) in this part of BS 1580 the following symbols apply.

NOTE 1 These symbols, which relate to the thread profile, have been taken from BS ISO 68-2:1998 because the thread profile specified in this part of BS 1580 is the same as that in BS ISO 68-2:1998. Also, these are the symbols given in BS 6528.

D major diameter of internal thread

D_1 minor diameter of internal thread

D_2 effective diameter of internal thread (see Note 2)

d major diameter of external thread

d_1 minor diameter of external thread

d_2 effective diameter of external thread (see Note 2)

H	height of fundamental triangle
P	pitch
T	tolerance
T_d	tolerances for d
T_{D1}	tolerances for D_1
T_{D2}	tolerances for D_2
T_{d1}	tolerances for d_1
T_{d2}	tolerances for d_2

NOTE 2 These are the symbols given for pitch diameter in BS 6528.

3.2.2 For the purposes of the remaining figures, and the tables and annexes, in this part of BS 1580, the symbols given in Annex D apply.

NOTE These symbols were given in the 1962 edition of this part of BS 1580 and have been retained for the convenience of users of the standard, in particular to enable the equations to be retained without alteration. The exception to this is the symbol for the pitch of the thread for which an upper case P is used throughout for consistency.

4 Profile of unified screw threads

4.1 Basic profile

The basic profile of unified screw threads shall be as shown in Figure 1.

NOTE This is the same as the profile of ISO inch screw threads specified in BS ISO 68-2.

4.2 Design profiles

The design profile of internal threads, i.e. the form of internal threads in their maximum material condition, shall be as shown in Figure 2a).

NOTE 1 This is the same as the basic profile except that, in practice, in order to avoid sharp corners at the root of the threads (at the major diameter), the roots may be rounded as shown by the dotted line and cleared beyond a width of $P/8$.

The design profile of external threads in their maximum material condition shall be as shown in Figure 2b). It shall be the same as the basic form shown in Figure 1 except that the root of the thread (at the minor diameter) shall be rounded to a radius equal to $0.144\ 3P$ below the flat of width $P/4$. (See Notes 3 to 8.)

The dimensions of the design profile of unified screw threads shall be as specified in Table 26.

NOTE 2 The design forms of the external and internal threads, shown in Figure 2, are such that, if a pair of screw threads of the same basic size (each in its maximum material condition) is assembled, contact between the two threads will be confined to the flanks over the radial depth of $(5/8)H$ as shown in Figure 1. The rounded root of the external thread will clear the flat of width $P/4$ at the minor diameter of the internal thread and the root of the internal thread will clear the flat of width $P/8$ at the major diameter of the external thread.

NOTE 3 To provide resistance to fatigue, it is important that the roots of the external threads should always be smoothly rounded within the limiting profiles specified. These limiting profiles permit manufacture by a new tool having a minimum crest radius of $0.108\ 3P$, and its retention in service until its crest radius wears to $0.144\ 3P$. (See Figure 2b and tolerance zone diagrams Figure 6, Figure 7 and Figure 8.) It is essential that the roots of external threads are never flat with sharp corners, as would result from the initial use of new screwing tools, rolls, or grinding wheels with flat crests.

NOTE 4 The root of an internal thread in the maximum material condition is shown as a flat of width $P/8$ in Figure 2 and the minimum major diameter (basic size) specified in the tables is based on this theoretically flat root. In practice, however, the root is rounded and cleared beyond the width of the $P/8$ flat.

NOTE 5 The actual forms of the roots of the external and internal threads cannot be proved by the GO screw gauges, since the crests of these gauges are flat and of width $P/4$ and $P/8$ for the respective gauges. The smoothness of the rounding at the roots of external threads can readily be inspected by optical methods.

NOTE 6 Although, basically, external threads of unified form should have flat crests, modern methods of manufacture result in large quantities of external threads with crests which are not flat but partially or even completely rounded. This departure from flat crests is not detrimental, so that while the limiting profiles within which the forms of the crests of external threads should lie is as shown by the solid lines in Figure 3, the minimum limiting profile should, in practice, be taken as rounded at the crest, as shown by the dashed line in Figure 3. (See also Annex C.)

NOTE 7 The actual form of any rounding of the crests of external threads cannot be proved by gauging since the roots of the GO screw gauges for these threads are cleared to accept maximum material threads with flat crests of width $P/8$. The major diameters of external threads should be checked by measurement, or with GO and NOT GO plain gap gauges.

NOTE 8 In some cases, the external thread may be required to have a rounded crest. This should be stated in the thread designation (see Clause 11). The normal radius is $0.108\ 3P$ [see Figure C.1d)].

Figure 1 Basic profile of unified screw threads

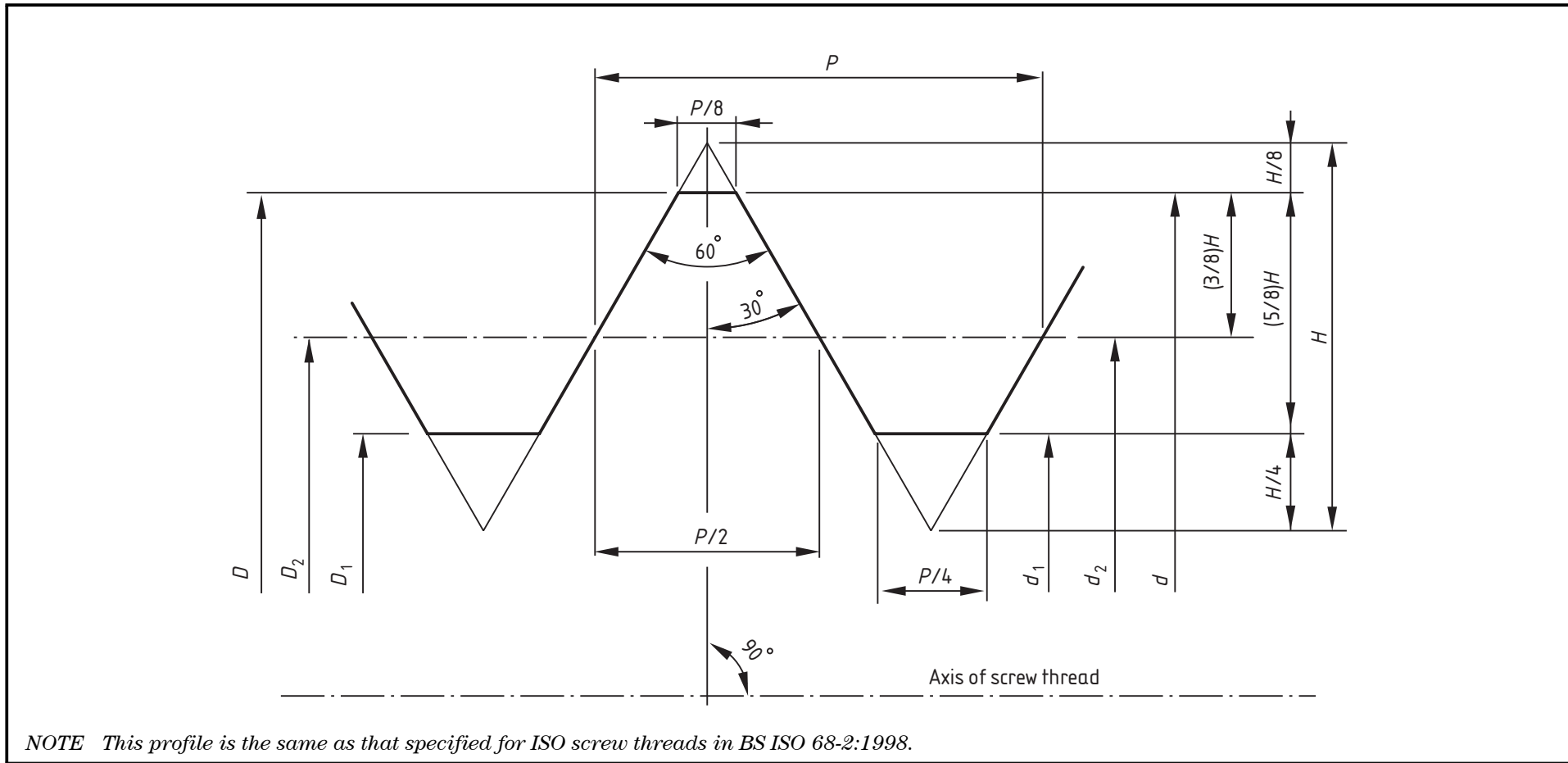
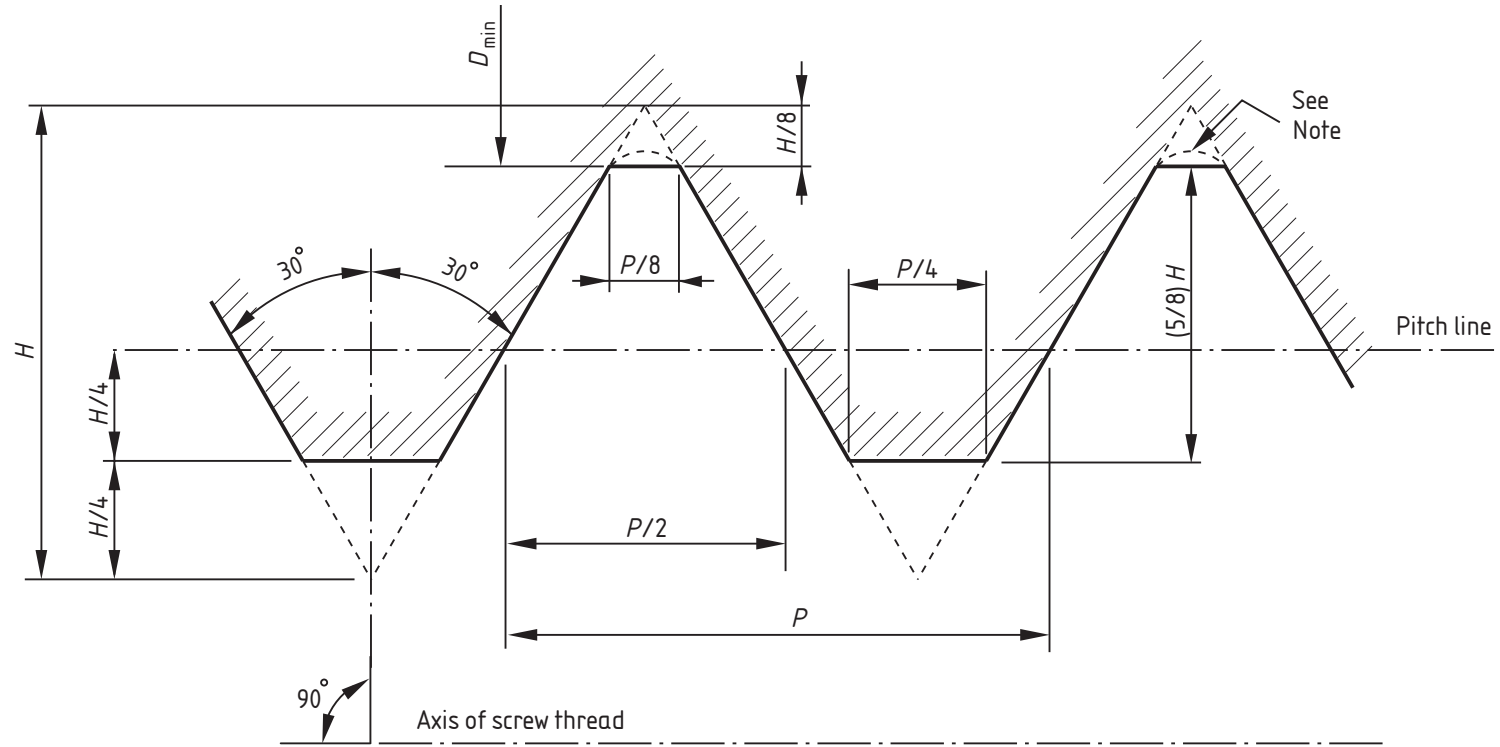

Figure 2 Design profiles of unified internal and external threads (maximum material condition)



NOTE In practice the root is rounded and cleared beyond a width of $P/8$.

a) Internal threads

Figure 2 Design profiles of unified internal and external threads (maximum material condition) (continued)

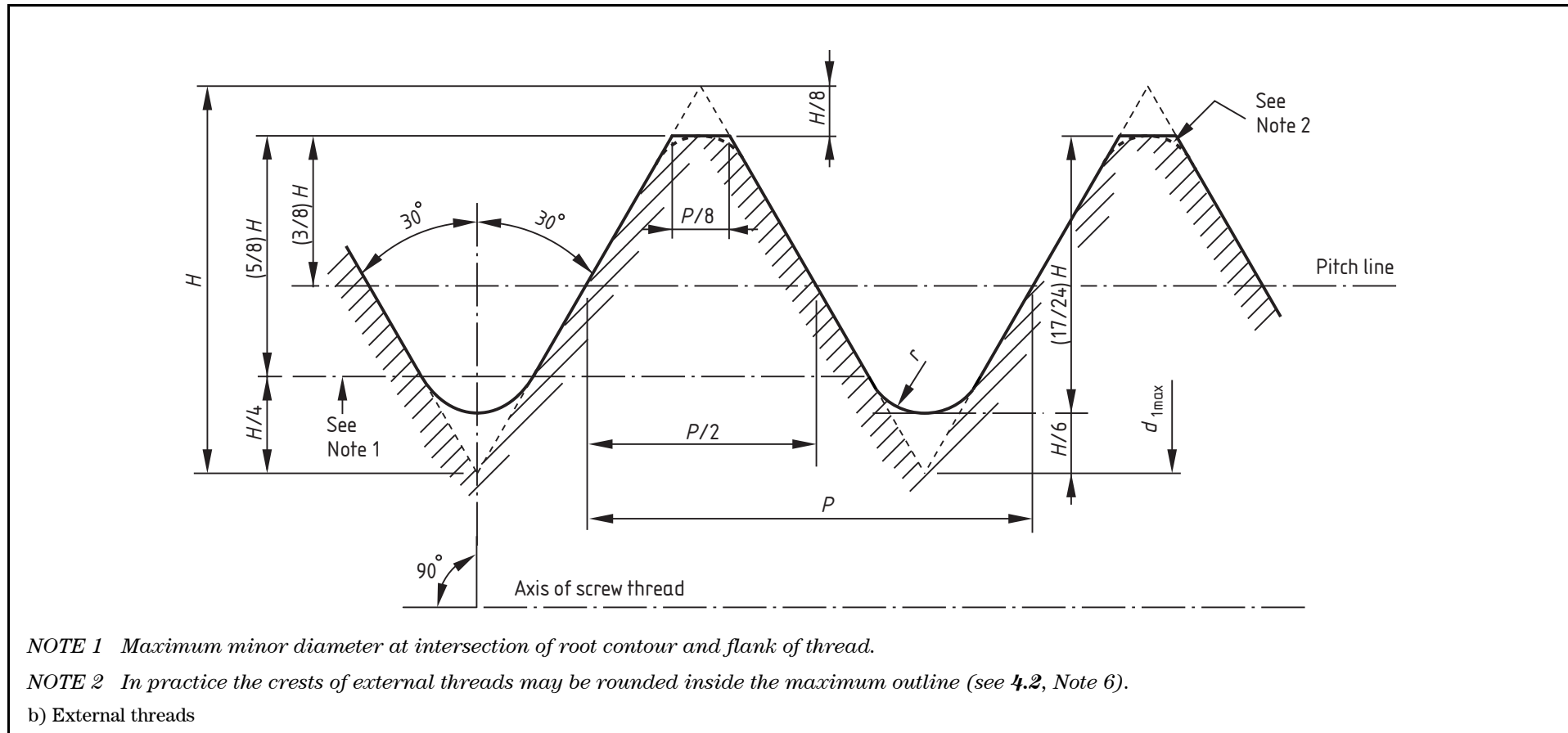

NOTE 1 Maximum minor diameter at intersection of root contour and flank of thread.

NOTE 2 In practice the crests of external threads may be rounded inside the maximum outline (see 4.2, Note 6).

b) External threads

Figure 3 Limiting profiles for crests of external threads

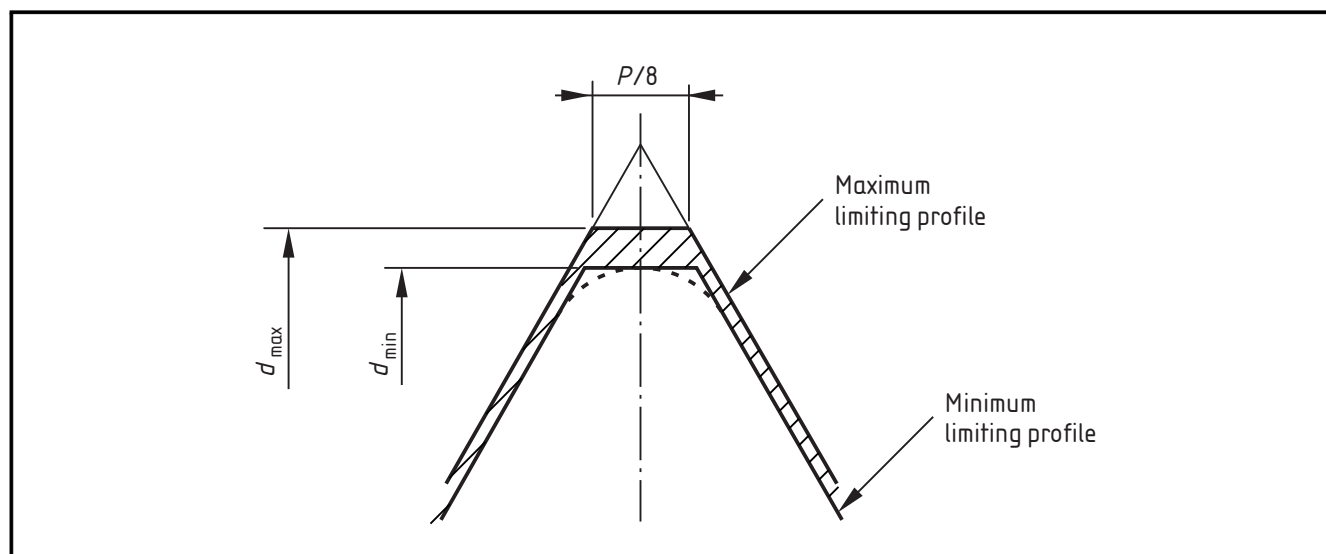

Section 2: Standard series

5 Diameter/pitch combinations

The diameter/pitch combinations for standard series unified screw threads shall be as specified in Table 1.

NOTE When selecting a diameter/pitch combination for a particular use the first choice should be a thread from the UNC or UNF series. If these are unsuitable, a thread from the UNEF or the constant pitch series should be selected. Of the latter, the preferred series are the 8 UN, 12 UN, 16 UN and 20 UN series. When selecting from the constant pitch series, a first choice diameter should be used if possible. If no first choice diameter is suitable, a second choice diameter should be used.

6 Tolerance classes of external and internal threads

External threads and internal threads shall be of one of the following tolerance classes:

- a) external threads:
 - Class 1A;
 - Class 2A;
 - Class 2AG (see Note 1);
 - Class 3A;
- b) internal threads:
 - Class 1B;
 - Class 2B;
 - Class 3B.

NOTE 1 Class 2AG external threads are Class 2A coated external threads for which there is a requirement for the allowance shown in Figure 4 to be retained after coating. This is necessary to allow, for example, for the use of a lubricant in high-temperature applications.

The relative magnitudes and positions of the effective diameter tolerance zones and allowances for finished uncoated threads shall be as shown in Figure 4.

NOTE 2 The bases of the tolerances and allowances shown in Figure 4 are given in Annex A.

NOTE 3 Information on the different tolerance classes and guidance on their use is given in Annex G.

NOTE 4 For information on the effect of different thread classes on strength, see BS 3580.

7 Limits of size, and tolerances, for uncoated threads

Limits of size, and tolerances, for finished uncoated threads shall be as given in Table 2.

NOTE 1 Limits of size and tolerances are not specified in Table 2 for Class 1A and Class 1B threads in the UNEF and the UN series because of their limited application.

NOTE 2 Because the UNC and the UNF series are extensively used, the limits and tolerances specified for these series in Table 2 are repeated in Tables 3 to 14, separated according to series and tolerance class, for the convenience of users of this standard.

NOTE 3 Figure 6, Figure 7 and Figure 8 illustrate, for Classes 1A and 1B, 2A and 2B, and 3A and 3B, respectively, the relationship between the diametral tolerance zones for a $\frac{1}{4}$ in 20 UNC internal thread and a $\frac{1}{4}$ in 20 UNC external thread.

NOTE 4 The effective diameter tolerances (see Annex A) have been derived from a three part formula which takes account of diameter, pitch and length of engagement. The normal tolerances have been calculated for specific lengths of engagement as follows.

- a) For UNC, UNF, 4 UN, 6 UN and 8 UN threads a length of engagement equal to one diameter has been used. These tolerances are recommended for lengths of engagement between 5P and $1\frac{1}{2}D$. It is important to note that any diameter/pitch combinations with 4, 6 or 8 t.p.i. not shown in Table 1 are UNS and their tolerances have been calculated using a length of engagement equal to 9P [see item b)].
- b) For UNEF, 12 UN, 16 UN, 20 UN, 28 UN, 32 UN and all UNS threads a length of engagement equal to 9P has been used. These tolerances are recommended for lengths of engagement between 5P and 15P.

When the length of engagement is outside the limits stated in a) or b), it is advisable to relate the tolerance to the actual length of engagement using the formulae given in Table A.1 or the nomogram given in Figure A.1.

NOTE 5 The major diameter tolerances for external threads are based solely on thread pitches and have been calculated from the formulae given in Annex A. The values of these tolerances are shown in Table 29 and have been used to compute the limits of size of standard threads in Table 2.

NOTE 6 The minor diameter tolerances for internal threads have been calculated from the formulae given in Annex A. These minor diameter tolerances apply to threads having a length of engagement between $\frac{2}{3}D$ and $1\frac{1}{2}D$ (where D has the meaning given in Annex D). If the length of engagement is appreciably outside the above limits, consideration should be given to the modification of the tolerances in Table 36. For guidance on these cases, and other cases where stripping strength is critical, see BS 3580.

NOTE 7 The tolerances on the minor diameter of external threads specified in Table 2 have been calculated from the formulae in Annex A. It is not usual to gauge directly the limits of external thread minor diameters, but the maximum limit is indirectly controlled by the GO screw gauge. It is important to ensure a smooth, well-formed root to the thread on articles subject to high stress or fatigue.

NOTE 8 No tolerance is specified for the major diameter of internal threads as it is considered that this dimension will be adequately controlled by the crests of the taps, or other cutting tools, used to produce the threads. The minimum limit is controlled by the GO screw gauge.

8 Allowances for uncoated threads

Allowances on the effective diameters of Class 1A and Class 2A threads shall be 30% of the effective diameter tolerances for the Class 2A threads computed for the normal length of engagement (see Clause 6 and Figure 4). No change shall be made in the allowances if the effective diameter tolerance is changed with different lengths of engagement. The difference between the maximum limit of the effective diameter and the basic effective diameter of these two classes of threads (which constitutes the allowance) shall also be applied to the maximum limits of their major and minor diameters.

9 Coated threads

NOTE 1 Electroplated coatings on threaded components (cadmium on steel components and zinc on steel components) are specified in BS 3382: Parts 1&2. Recommendations on the appropriate system of gauging for coated threads are given in BS 919-1:2007, Annex D.

The relative magnitudes and positions of the effective diameter tolerance zones for external threads and internal threads prior to and after coating shall be in accordance with the following requirements, as shown in Figure 5.

NOTE 2 These requirements are applicable to coatings conforming to BS 3382: Parts 1&2, which are of the order of 0.000 2 in. For thicker coatings, special provisions are necessary (see BS 3382-7).

- a) *Class 1A, external threads.* The allowance shall be maintained after coating and the coated thread shall be accepted by the same GO screw gauge as the uncoated thread. The upper limits for all diameters of the thread before coating shall be 0.001 5 in less than the corresponding maximum diametral limits given in Table 2; the lower limit shall not be changed.
- b) *Class 2A, external threads.* In the case of Class 2A coated threads, it shall be permissible for the allowance to be absorbed by the thickness of the coating (see Note 3). Such threads shall be accepted by a GO screw gauge of basic size. The limits of the coated threads before coating shall be those given in Table 2.

NOTE 3 The minimum clearance at assembly can therefore be zero.

- c) *Class 2AG, external threads.* Both the maximum and minimum diametral limits before coating shall be 0.001 in less than those given in Table 2 for Class 2A. After coating the maximum tabulated limits shall not be exceeded.
- d) *Class 3A, external threads.* Since there is no allowance, the upper limits for all diameters of the thread before coating shall be 0.001 in less than the maximum diametral limits given in Table 2. After coating the finished product shall be accepted by a GO screw gauge of basic size. In view of the small tolerance, the lower diametral limits of size before coating shall be 0.001 in below the minimum diametral limits given in Table 2.
- e) *Internal threads (all classes).* After coating, internal threads of all classes shall be accepted by a GO screw gauge of basic size. The upper limit shall not be changed.

NOTE 4 An increase of 0.001 in on the lower limit for coating is recommended. However, in the case of Class 3B internal threads, this reduction in the tolerance is unduly large and it is strongly recommended that coated Class 2B internal threads be used instead of Class 3B internal threads where coating is required.

Figure 4 Classes of unified screw threads – Effective diameter tolerance zones of finished uncoated threads

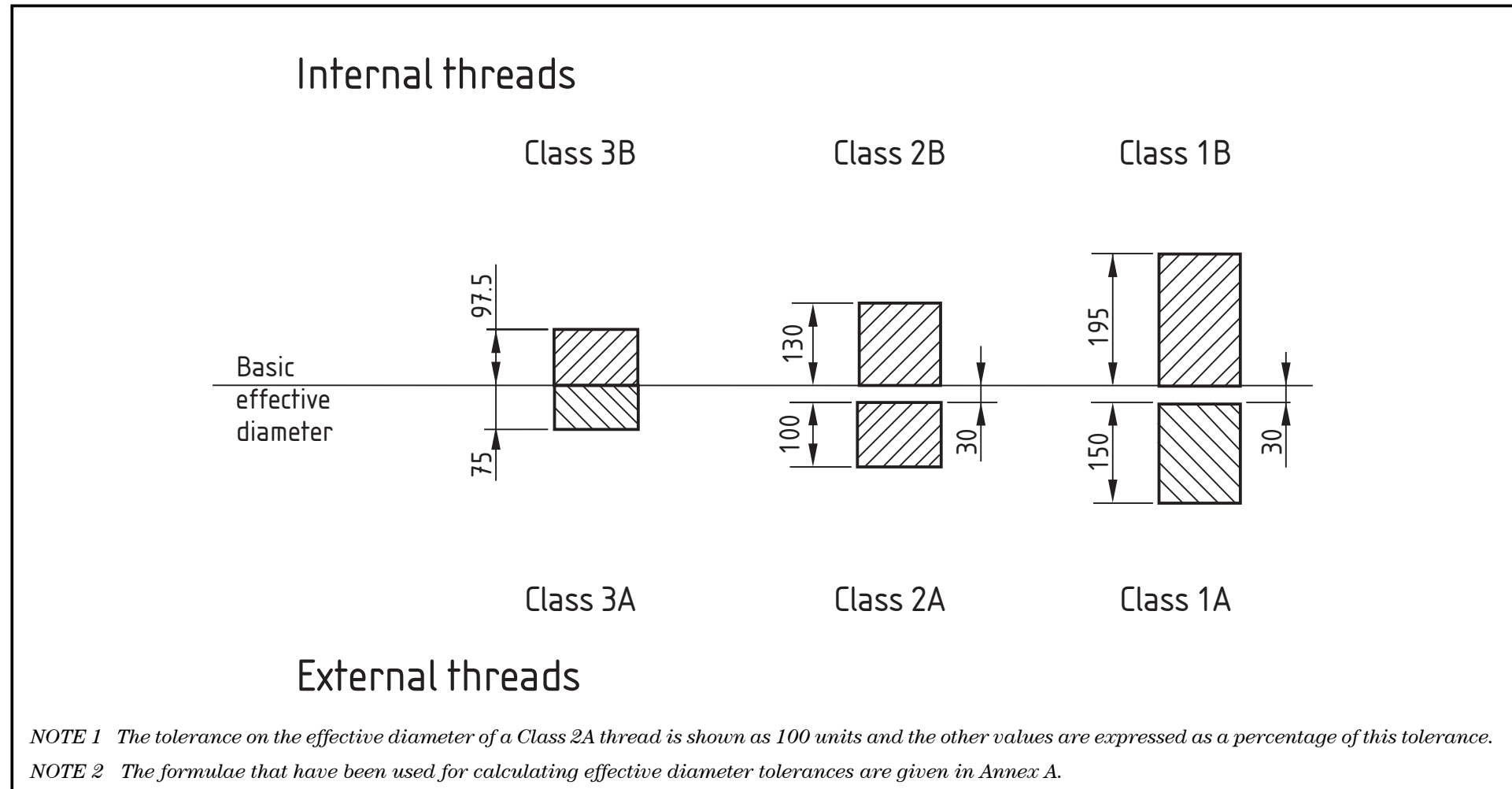
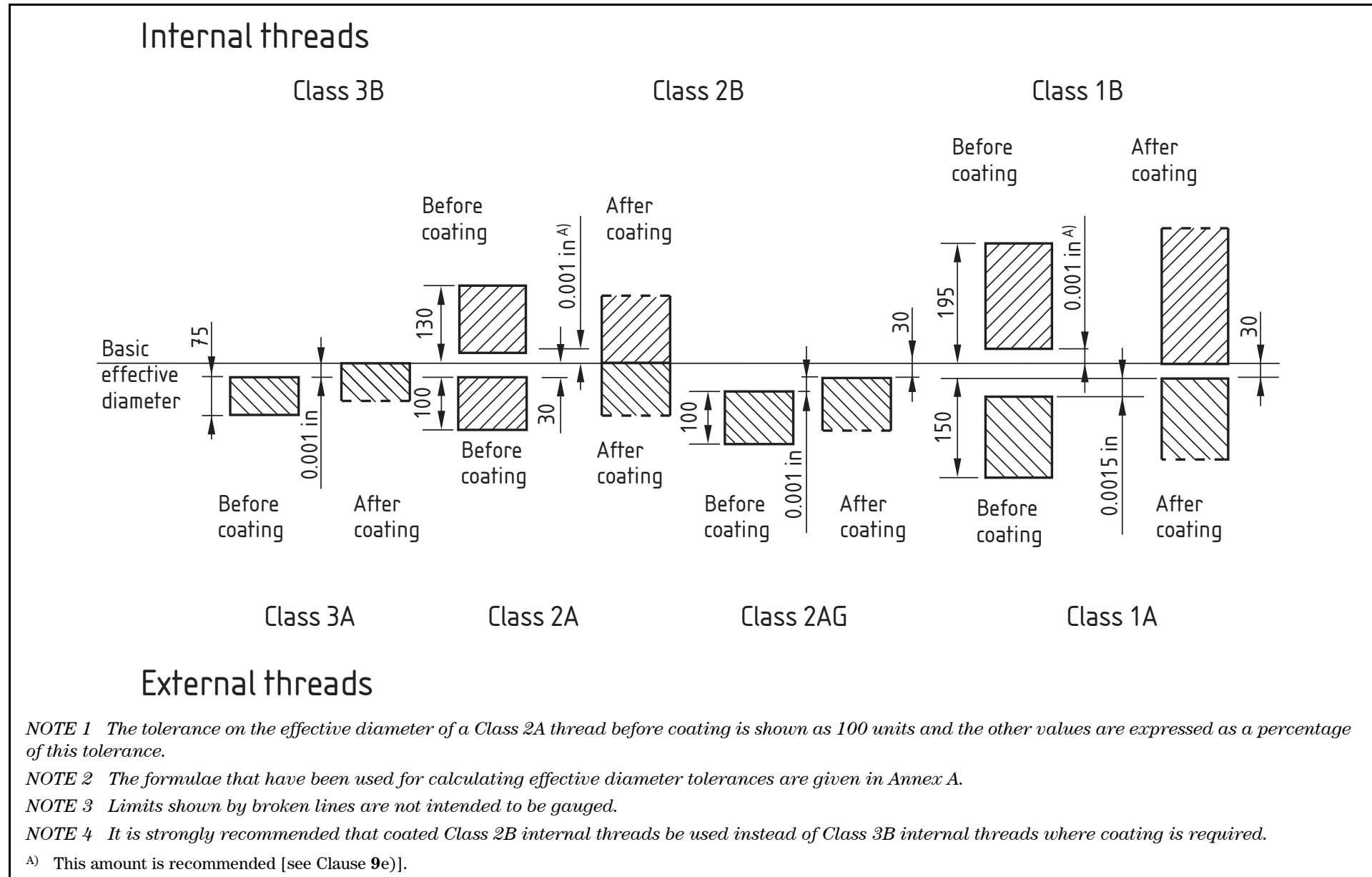

Figure 5 Classes of unified screw threads – Effective diameter tolerance zones of coated threads before and after coating



10 Gauges

Where screw gauges are used to check the dimensions of the screw threads, screw gauges conforming to BS 919-1 and BS 919-4 shall be used.

NOTE In exceptional cases where the provision of screw gauges is uneconomical, direct measurement of the thread elements may be used instead.

Figure 6 Tolerance zones for unified threads, Class 1A external thread and Class 1B internal thread

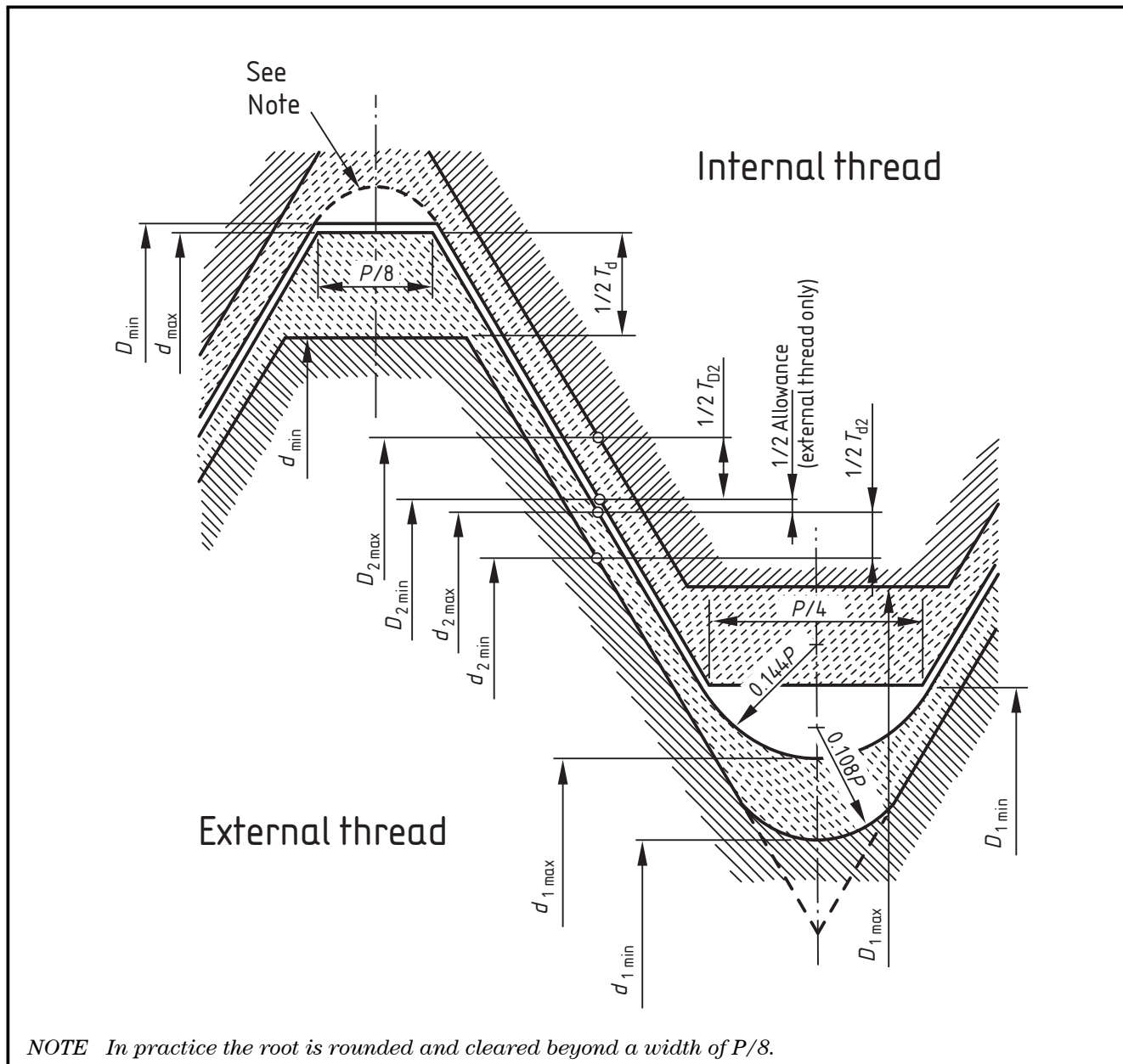
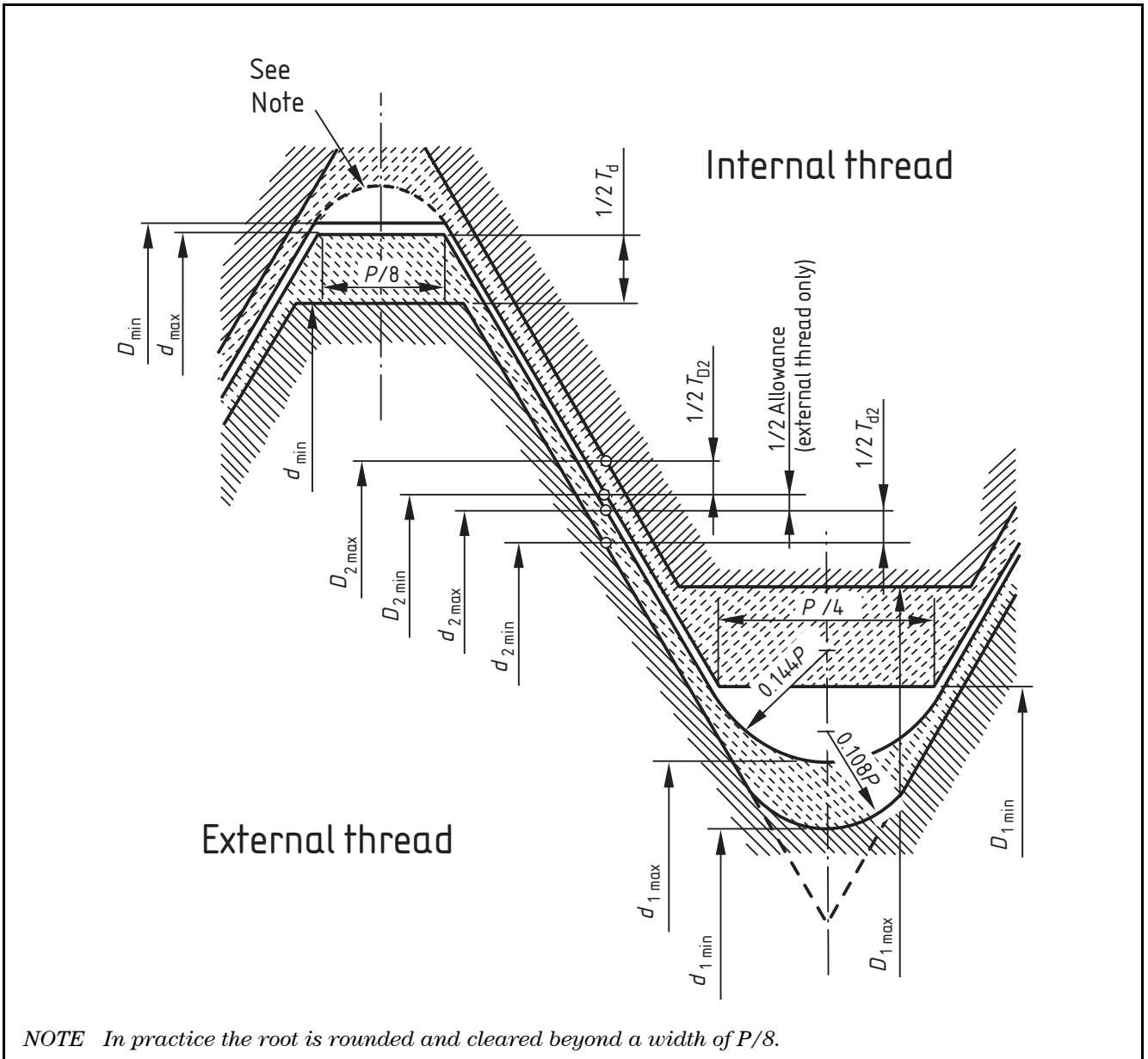
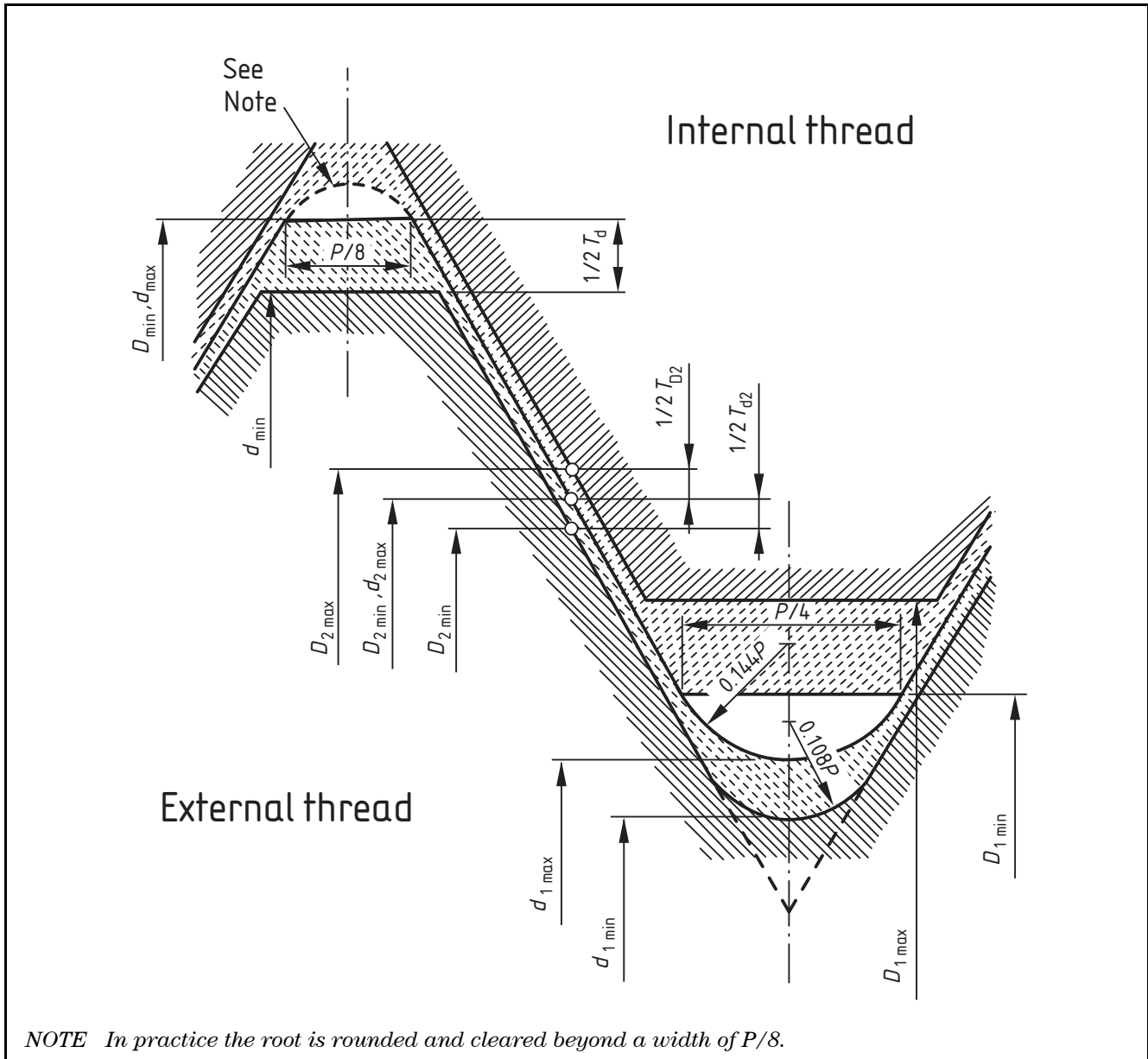

Figure 7 Tolerance zones for unified threads, Class 2A external thread and Class 2B internal thread



Licensed Copy: :FULLNAME, : DATE, Uncontrolled Copy, (c) BSI

Figure 8 Tolerance zones for unified threads, Class 3A external thread and Class 3B internal thread



11 Designation of unified screw threads

11.1 Basic designation

The basic designation shall be used for threads with standard lengths of engagement (see Annex A) and shall comprise the following elements:

- the nominal size (which is equal to the basic major diameter) expressed as a fraction or a decimal equivalent. (Where decimal equivalents are used they shall be shown in four-place decimals, but omitting the cipher in the fourth place.)
- the number of threads per inch;
- the thread series, UNC, UNF, UNEF or UN;
- the thread class, 1A, 2A, 2AG, 3A, 1B, 2B or 3B.

EXAMPLES

$\frac{1}{4}$ — 20 UNC — 2A
 .250 — 20 UNC — 2A
 .4375 — 20 UNF — 2A
 .4375 — 20 UNF — 3A

NOTE For uncoated threads the maximum and minimum effective diameters may be added to the designation.

EXAMPLE

$\frac{1}{4}$ — 20 UNC — 2A
 EFF. DIA. .2164 — .2127

11.2 Designation of coated threads

11.2.1 General

For coated threads, the basic designation specified in 11.1 shall be followed by the parameters specified in 11.2.2 or 11.2.3, as applicable.

11.2.2 External threads

11.2.2.1 Class 1A threads

For coated Class 1A external threads, the maximum major diameter and maximum effective diameter shall be given followed by AFTER COATING, thereby indicating that the thread before coating has to have special provisions to allow for coating thickness.

The major diameter and effective diameter limits of size before coating [calculated in accordance with Clause 9a)] shall be given followed by SPL (standing for special) and by BEFORE COATING.

EXAMPLE

$\frac{1}{4}$ — 20 UNC — 1A
 MAJOR DIA. .2489 MAX.
 EFF.DIA. .2164 MAX. AFTER COATING
 MAJOR DIA. .2474 — .2367 SPL
 EFF.DIA. .2149 — .2108 SPL BEFORE COATING

11.2.2.2 Class 2A threads

For coated Class 2A external threads, the basic major diameter and the basic effective diameter (which are equivalent to the maximum major diameter and the maximum effective diameter, respectively) shall be given followed by AFTER COATING. The major diameter and effective diameter limits of size before coating shall also be given followed by BEFORE COATING.

EXAMPLE

$\frac{3}{4}$ — 10 UNC — 2A
 MAJOR DIA. .7500 MAX.
 EFF.DIA. .6850 MAX. AFTER COATING
 MAJOR DIA. .7482 — .7353 SPL
 EFF.DIA. .6832 — .6773 SPL BEFORE COATING

NOTE The allowance given in the dimensional tables for Class 2A threads is sufficient to accommodate coating thicknesses of the order of 0.000 2 in.

11.2.2.3 Class 2AG threads

For coated Class 2AG external threads, the maximum major diameter and maximum effective diameter of the corresponding Class 2A thread shall be given followed by AFTER COATING thereby indicating that the allowance has to be maintained. The major diameter and effective diameter limits of size before coating [calculated in accordance with Clause 9a)] shall also be given followed by SPL (to stand for special) and by BEFORE COATING.

EXAMPLE

$$\frac{3}{4} - 10 \text{ UNC} - 2\text{AG}$$

MAJOR DIA. .7482 MAX.

EFF.DIA. .6832 MAX. AFTER COATING

MAJOR DIA. .7472 — .7343 SPL

EFF.DIA. .6822 — .6763 SPL BEFORE COATING

11.2.2.4 Class 3A threads

For coated Class 3A external threads, the basic major diameter and basic effective diameter (which are equivalent to the maximum major diameter and maximum effective diameter, respectively) shall be given followed by AFTER COATING thereby indicating that the thread before coating has to have special provisions to allow for coating thickness. The major diameter and effective diameter limits of size before coating [calculated in accordance with Clause 9a)] shall be given followed by SPL (standing for special) and by BEFORE COATING.

EXAMPLE

$$\frac{1}{4} - 28 \text{ UNF} - 3\text{A}$$

MAJOR DIA. .2500 MAX.

EFF.DIA. .2268 MAX. AFTER COATING

MAJOR DIA. .2490 — .2425 SPL

EFF.DIA. .2258 — .2233 SPL BEFORE COATING

11.2.3 Internal threads

For coated Class 1B, Class 2B and Class 3B internal threads, the minimum minor diameter and minimum effective diameter shall be given followed by AFTER COATING. The minor diameter and effective diameter limits of size before coating [calculated in accordance with Clause 9a)] shall be given followed by SPL (standing for special) and by BEFORE COATING.

EXAMPLES

$$\frac{1}{4} - 20 \text{ UNC} - 1\text{B}$$

MINOR DIA. .1959 MIN.

EFF.DIA. .2175 MIN. AFTER COATING

MINOR DIA. .1969 — .2074 SPL

EFF.DIA. .2185 — .2248 SPL BEFORE COATING

$\frac{3}{4}$ — 10 UNC — 2B

MINOR DIA. .6417 MIN.
EFF.DIA. .6850 MIN. AFTER COATING

MINOR DIA. .6427 — .6627 SPL
EFF.DIA. .6860 — .6927 SPL BEFORE COATING

$\frac{1}{4}$ — 28 UNF — 3B

MINOR DIA. .2113 MIN.
EFF.DIA. .2268 MIN. AFTER COATING

MINOR DIA. .2123 — .2190 SPL
EFF.DIA. .2278 — .2300 SPL BEFORE COATING

NOTE The before-coating limits for all of the examples have been calculated to be suitable for a coating thickness of 0.000 2 in on the thread flanks.

11.3 Designation of left-hand threads

For left-hand threads the basic designation specified in 11.1 shall be followed by LH.

EXAMPLE

$\frac{1}{4}$ — 20 UNC — 3A — LH

11.4 Designation of threads with a special length of engagement

For threads which have a special length of engagement differing from that for which the standard effective diameter tolerances are applicable, as indicated in Clause 7 Note 4, the thread class symbol shall be preceded by SE (standing for special engagement). The effective diameter limits of size shall be given. The length of engagement (LE) shall also be given to two decimal places.

EXAMPLE

$\frac{1}{2}$ — 13 UNC — SE 2A
EFF.DIA. .4485 — .4431
LE 1.00

11.5 Designation of threads with modified crests

If the limits of size of the major diameter of an external thread or the minor diameter of an internal thread have been modified, but the thread class and effective diameter limits have not been changed, MOD shall be added after the thread class. The modified limits of size shall also be given, followed by MOD.

EXAMPLE

$\frac{3}{8}$ — 24 UNF — 3A MOD
MAJOR DIA. .3720 — .3648 MOD

For external threads with rounded crests ROUNDED CREST shall be added to the designation after the thread series.

EXAMPLE

$\frac{1}{4}$ — 20 UNC ROUNDED CREST — 2A

11.6 Designation of threads with other alterations

For standard series threads that have alterations other than changes to the effective diameter limits for a special length of engagement or the modification of the crests or adjustment to the limits of size to accommodate a coating, the designation shall be in accordance with the following examples.

EXAMPLES

$\frac{7}{16}$ — 24 UNIFIED FORM SPECIAL — EXT.

MAJOR DIA. .4340 — .4280 SPL

EFF.DIA. .4065 — .4025 SPL

LE .38

$\frac{1}{2}$ — 13 UNIFIED FORM SPECIAL — INT.

MINOR DIA. .4167 — DEC .4284 SPL

EFF.DIA. .4500 — .4580 SPL

LE .50

Table 1 Unified screw threads, standard series

1	2	3	4	5	6	7	8	9	10	11	12	13	14	15
Sizes		Basic major diameter	Threads per inch											Sizes in
1st choice in	2nd choice in		Series with graded pitches			Series with constant pitches								
			Coarse UNC	Fine UNF	Extra fine UNEF	4 UN	6 UN	8 UN	12 UN	16 UN	20 UN	28 UN	32 UN	
$\frac{1}{4}$		0.250 0	20	28	32	—	—	—	—	—	UNC	UNF	UNEF	$\frac{1}{4}$
$\frac{5}{16}$		0.312 5	18	24	32	—	—	—	—	—	20	28	UNEF	$\frac{5}{16}$
$\frac{3}{8}$		0.375 0	16	24	32	—	—	—	—	UNC	20	28	UNEF	$\frac{3}{8}$
$\frac{7}{16}$		0.437 5	14	20	28	—	—	—	—	16	UNF	UNEF	32	$\frac{7}{16}$
$\frac{1}{2}$		0.500 0	13	20	28	—	—	—	—	16	UNF	UNEF	32	$\frac{1}{2}$
$\frac{9}{16}$		0.562 5	12	18	24	—	—	—	UNC	16	20	28	32	$\frac{9}{16}$
$\frac{5}{8}$		0.625 0	11	18	24	—	—	—	12	16	20	28	32	$\frac{5}{8}$
	$\frac{11}{16}$	0.687 5	—	—	24	—	—	—	12	16	20	28	32	$\frac{11}{16}$
$\frac{3}{4}$		0.750 0	10	16	20	—	—	—	12	UNF	UNEF	28	32	$\frac{3}{4}$
	$\frac{13}{16}$	0.812 5	—	—	20	—	—	—	12	16	UNEF	28	32	$\frac{13}{16}$
	$\frac{7}{8}$	0.875 0	9	14	20	—	—	—	12	16	UNEF	28	32	$\frac{7}{8}$
	$\frac{15}{16}$	0.937 5	—	—	20	—	—	—	12	16	UNEF	28	32	$\frac{15}{16}$
1		1.000 0	8	12	20	—	—	UNC	UNF	16	UNEF	28	32	1
	$\frac{1}{16}$	1.062 5	—	—	18	—	—	8	12	16	20	28	—	$\frac{1}{16}$
$\frac{1}{8}$		1.125 0	7	12	18	—	—	8	UNF	16	20	28	—	$\frac{1}{8}$
	$\frac{3}{16}$	1.187 5	—	—	18	—	—	8	12	16	20	28	—	$\frac{3}{16}$
$\frac{1}{4}$		1.250 0	7	12	18	—	—	8	UNF	16	20	28	—	$\frac{1}{4}$
	$\frac{5}{16}$	1.312 5	—	—	18	—	—	8	12	16	20	28	—	$\frac{5}{16}$
$\frac{3}{8}$		1.375 0	6	12	18	—	UNC	8	UNF	16	20	28	—	$\frac{3}{8}$
	$\frac{7}{16}$	1.437 5	—	—	18	—	6	8	12	16	20	28	—	$\frac{7}{16}$
$\frac{1}{2}$		1.500 0	6	12	18	—	UNC	8	UNF	16	20	28	—	$\frac{1}{2}$
	$\frac{9}{16}$	1.562 5	—	—	18	—	6	8	12	16	20	—	—	$\frac{9}{16}$
$\frac{5}{8}$		1.625 0	—	—	18	—	6	8	12	16	20	—	—	$\frac{5}{8}$
	$\frac{11}{16}$	1.687 5	—	—	18	—	6	8	12	16	20	—	—	$\frac{11}{16}$
$\frac{3}{4}$		1.750 0	5	—	—	—	6	8	12	16	20	—	—	$\frac{3}{4}$
	$\frac{13}{16}$	1.812 5	—	—	—	—	6	8	12	16	20	—	—	$\frac{13}{16}$
$\frac{7}{8}$		1.875 0	—	—	—	—	6	8	12	16	20	—	—	$\frac{7}{8}$
	$\frac{15}{16}$	1.937 5	—	—	—	—	6	8	12	16	20	—	—	$\frac{15}{16}$

Table 1 Unified screw threads, standard series (continued)

1	2	3	4	5	6	7	8	9	10	11	12	13	14	15
Sizes		Basic major diameter	Threads per inch											Sizes in
1st choice in	2nd choice in		Series with graded pitches			Series with constant pitches								
			Coarse UNC	Fine UNF	Extra fine UNEF	4 UN	6 UN	8 UN	12 UN	16 UN	20 UN	28 UN	32 UN	
2		2.000 0	4½	—	—	—	6	8	12	16	20	—	—	2
	2⅛	2.125 0	—	—	—	—	6	8	12	16	20	—	—	2⅛
2¼		2.250 0	4½	—	—	—	6	8	12	16	20	—	—	2¼
	2⅜	2.375 0	—	—	—	—	6	8	12	16	20	—	—	2⅜
2½		2.500 0	4	—	—	UNC	6	8	12	16	20	—	—	2½
	2⅝	2.625 0	—	—	—	4	6	8	12	16	20	—	—	2⅝
2¾		2.750 0	4	—	—	UNC	6	8	12	16	20	—	—	2¾
	2⅞	2.875 0	—	—	—	4	6	8	12	16	20	—	—	2⅞
3		3.000 0	4	—	—	UNC	6	8	12	16	20	—	—	3
	3⅛	3.125 0	—	—	—	4	6	8	12	16	—	—	—	3⅛
3¼		3.250 0	4	—	—	UNC	6	8	12	16	—	—	—	3¼
	3⅜	3.375 0	—	—	—	4	6	8	12	16	—	—	—	3⅜
3½		3.500 0	4	—	—	UNC	6	8	12	16	—	—	—	3½
	3⅝	3.625 0	—	—	—	4	6	8	12	16	—	—	—	3⅝
3¾		3.750 0	4	—	—	UNC	6	8	12	16	—	—	—	3¾
	3⅞	3.875 0	—	—	—	4	6	8	12	16	—	—	—	3⅞
4		4.000 0	4	—	—	UNC	6	8	12	16	—	—	—	4
	4⅛	4.125 0	—	—	—	4	6	8	12	16	—	—	—	4⅛
4¼		4.250 0	—	—	—	4	6	8	12	16	—	—	—	4¼
	4⅜	4.375 0	—	—	—	4	6	8	12	16	—	—	—	4⅜
4½		4.500 0	—	—	—	4	6	8	12	16	—	—	—	4½
	4⅝	4.625 0	—	—	—	4	6	8	12	16	—	—	—	4⅝
4¾		4.750 0	—	—	—	4	6	8	12	16	—	—	—	4¾
	4⅞	4.875 0	—	—	—	4	6	8	12	16	—	—	—	4⅞
5		5.000 0	—	—	—	4	6	8	12	16	—	—	—	5
	5⅛	5.125 0	—	—	—	4	6	8	12	16	—	—	—	5⅛
5¼		5.250 0	—	—	—	4	6	8	12	16	—	—	—	5¼
	5⅜	5.375 0	—	—	—	4	6	8	12	16	—	—	—	5⅜
5½		5.500 0	—	—	—	4	6	8	12	16	—	—	—	5½
	5⅝	5.625 0	—	—	—	4	6	8	12	16	—	—	—	5⅝
5¾		5.750 0	—	—	—	4	6	8	12	16	—	—	—	5¾
	5⅞	5.875 0	—	—	—	4	6	8	12	16	—	—	—	5⅞
6		6.000 0	—	—	—	4	6	8	12	16	—	—	—	6

NOTE 1 When the designation symbols UNC, UNF or UNEF appear in a constant pitch series, it means that the place of that particular diameter/pitch combination is taken by the equivalent combination in the series indicated.

NOTE 2 Designations of the standard diameter/pitch combinations given in this table, are specified in Clause 11.

NOTE 3 The diameters given in Column 1 should be used in preference to those in Column 2.

NOTE 4 For values of the basic dimensions of the UNC, UNF and UNEF threads, see Table 15, Table 16 and Table 17, respectively. Those for the threads in the constant pitch series are given in Table 18 to Table 25.

NOTE 5 Whilst this table finishes at 6 in, it may be necessary in some applications to exceed this diameter (see Section 3.)

Table 2 Unified screw threads, standard series – Limits of size

1	2	3	4	5	6	7	8	9	10	11	12	13	14	15	16	17	18
Nominal size and threads per inch	Series designation	External threads									Internal threads						
		Class	Allowance	Major diameter		Effective diameter			Minor diameter		Class	Minor diameter		Effective diameter			Major diameter
				Max. in	Min. in	Max. in	Min. in	Tol. in	Max. in	Min. in		Min. in	Max. in	Min. in	Max. in	Tol. in	
1/4 — 20	UNC	1A	0.001 1	0.248 9	0.236 7	0.216 4	0.210 8	0.005 6	0.187 6	0.178 4	1B	0.195 9	0.207 4	0.217 5	0.224 8	0.007 3	0.250 0
		2A	0.001 1	0.248 9	0.240 8	0.216 4	0.212 7	0.003 7	0.187 6	0.180 3	2B	0.195 9	0.207 4	0.217 5	0.222 3	0.004 8	0.250 0
		3A	0.000 0	0.250 0	0.241 9	0.217 5	0.214 7	0.002 8	0.188 7	0.182 3	3B	0.195 9	0.206 7	0.217 5	0.221 1	0.003 6	0.250 0
1/4 — 28	UNF	1A	0.001 0	0.249 0	0.239 2	0.225 8	0.220 8	0.005 0	0.205 2	0.197 6	1B	0.211 3	0.219 7	0.226 8	0.233 3	0.006 5	0.250 0
		2A	0.001 0	0.249 0	0.242 5	0.225 8	0.222 5	0.003 3	0.205 2	0.199 3	2B	0.211 3	0.219 7	0.226 8	0.231 1	0.004 3	0.250 0
		3A	0.000 0	0.250 0	0.243 5	0.226 8	0.224 3	0.002 5	0.206 2	0.201 1	3B	0.211 3	0.219 0	0.226 8	0.230 0	0.003 2	0.250 0
1/4 — 32	UNEF	2A	0.001 0	0.249 0	0.243 0	0.228 7	0.225 5	0.003 2	0.210 7	0.205 3	2B	0.216 2	0.223 6	0.229 7	0.233 9	0.004 2	0.250 0
		3A	0.000 0	0.250 0	0.244 0	0.229 7	0.227 3	0.002 4	0.211 7	0.207 1	3B	0.216 2	0.222 9	0.229 7	0.232 8	0.003 1	0.250 0
5/16 — 18	UNC	1A	0.001 2	0.311 3	0.298 2	0.275 2	0.269 1	0.006 1	0.243 1	0.233 0	1B	0.252 4	0.265 1	0.276 4	0.284 3	0.007 9	0.312 5
		2A	0.001 2	0.311 3	0.302 6	0.275 2	0.271 2	0.004 0	0.243 1	0.235 1	2B	0.252 4	0.265 1	0.276 4	0.281 7	0.005 3	0.312 5
		3A	0.000 0	0.312 5	0.303 8	0.276 4	0.273 4	0.003 0	0.244 3	0.237 3	3B	0.252 4	0.263 0	0.276 4	0.280 3	0.003 9	0.312 5
5/16 — 20	UN	2A	0.001 2	0.311 3	0.303 2	0.278 8	0.274 8	0.004 0	0.250 0	0.242 4	2B	0.258 4	0.269 9	0.280 0	0.285 2	0.005 2	0.312 5
		3A	0.000 0	0.312 5	0.304 4	0.280 0	0.277 0	0.003 0	0.251 2	0.244 6	3B	0.258 4	0.268 0	0.280 0	0.283 9	0.003 9	0.312 5
5/16 — 24	UNF	1A	0.001 1	0.311 4	0.300 6	0.284 3	0.278 8	0.005 5	0.260 3	0.251 8	1B	0.267 4	0.277 1	0.285 4	0.292 5	0.007 1	0.312 5
		2A	0.001 1	0.311 4	0.304 2	0.284 3	0.280 6	0.003 7	0.260 3	0.253 6	2B	0.267 4	0.277 1	0.285 4	0.290 2	0.004 8	0.312 5
		3A	0.000 0	0.312 5	0.305 3	0.285 4	0.282 7	0.002 7	0.261 4	0.255 7	3B	0.267 4	0.275 4	0.285 4	0.289 0	0.003 6	0.312 5
5/16 — 28	UN	2A	0.001 0	0.311 5	0.305 0	0.288 3	0.284 9	0.003 4	0.267 7	0.261 7	2B	0.273 8	0.282 2	0.289 3	0.293 7	0.004 4	0.312 5
		3A	0.000 0	0.312 5	0.306 0	0.289 3	0.286 7	0.002 6	0.268 7	0.263 5	3B	0.273 8	0.280 7	0.289 3	0.292 6	0.003 3	0.312 5
5/16 — 32	UNEF	2A	0.001 0	0.311 5	0.305 5	0.291 2	0.288 0	0.003 2	0.273 2	0.267 8	2B	0.278 7	0.286 1	0.292 2	0.296 4	0.004 2	0.312 5
		3A	0.000 0	0.312 5	0.306 5	0.292 2	0.289 8	0.002 4	0.274 2	0.269 6	3B	0.278 7	0.284 7	0.292 2	0.295 3	0.003 1	0.312 5
3/8 — 16	UNC	1A	0.001 3	0.373 7	0.359 5	0.333 1	0.326 6	0.006 5	0.297 0	0.286 0	1B	0.307 3	0.321 4	0.334 4	0.342 9	0.008 5	0.375 0
		2A	0.001 3	0.373 7	0.364 3	0.333 1	0.328 7	0.004 4	0.297 0	0.288 1	2B	0.307 3	0.321 4	0.334 4	0.340 1	0.005 7	0.375 0
		3A	0.000 0	0.375 0	0.365 6	0.334 4	0.331 1	0.003 3	0.298 3	0.290 5	3B	0.307 3	0.318 2	0.334 4	0.338 7	0.004 3	0.375 0
3/8 — 20	UN	2A	0.001 2	0.373 8	0.365 7	0.341 3	0.337 2	0.004 1	0.312 5	0.304 8	2B	0.320 9	0.332 4	0.342 5	0.347 9	0.005 4	0.375 0
		3A	0.000 0	0.375 0	0.366 9	0.342 5	0.339 4	0.003 1	0.313 7	0.307 0	3B	0.320 9	0.329 7	0.342 5	0.346 5	0.004 0	0.375 0
3/8 — 24	UNF	1A	0.001 1	0.373 9	0.363 1	0.346 8	0.341 1	0.005 7	0.322 8	0.314 1	1B	0.329 9	0.339 6	0.347 9	0.355 3	0.007 4	0.375 0
		2A	0.001 1	0.373 9	0.366 7	0.346 8	0.343 0	0.003 8	0.322 8	0.316 0	2B	0.329 9	0.339 6	0.347 9	0.352 8	0.004 9	0.375 0
		3A	0.000 0	0.375 0	0.367 8	0.347 9	0.345 0	0.002 9	0.323 9	0.318 0	3B	0.329 9	0.337 2	0.347 9	0.351 6	0.003 7	0.375 0
3/8 — 28	UN	2A	0.001 1	0.373 9	0.367 4	0.350 7	0.347 1	0.003 6	0.330 1	0.323 9	2B	0.336 3	0.344 7	0.351 8	0.356 4	0.004 6	0.375 0
		3A	0.000 0	0.375 0	0.368 5	0.351 8	0.349 1	0.002 7	0.331 2	0.325 9	3B	0.336 3	0.342 6	0.351 8	0.355 3	0.003 5	0.375 0

Table 2 Unified screw threads, standard series – Limits of size (continued)

1	2	3	4	5	6	7	8	9	10	11	12	13	14	15	16	17	18
Nominal size and threads per inch	Series designation	External threads									Internal threads						
		Class	Allowance	Major diameter		Effective diameter			Minor diameter		Class	Minor diameter		Effective diameter			Major diameter
				Max. in	Min. in	Max. in	Min. in	Tol. in	Max. in	Min. in		Min. in	Max. in	Min. in	Max. in	Tol. in	Min. in
3/8 — 32	UNEF	2A	0.001 0	0.374 0	0.368 0	0.353 7	0.350 3	0.003 4	0.335 7	0.330 1	2B	0.341 2	0.348 6	0.354 7	0.359 1	0.004 4	0.375 0
		3A	0.000 0	0.375 0	0.369 0	0.354 7	0.352 2	0.002 5	0.336 7	0.332 0	3B	0.341 2	0.346 9	0.354 7	0.358 0	0.003 3	0.375 0
7/16 — 14	UNC	1A	0.001 4	0.436 1	0.420 6	0.389 7	0.382 6	0.007 1	0.348 5	0.336 3	1B	0.360 2	0.376 0	0.391 1	0.400 3	0.009 2	0.437 5
		2A	0.001 4	0.436 1	0.425 8	0.389 7	0.385 0	0.004 7	0.348 5	0.338 7	2B	0.360 2	0.376 0	0.391 1	0.397 2	0.006 1	0.437 5
		3A	0.000 0	0.437 5	0.427 2	0.391 1	0.387 6	0.003 5	0.349 9	0.341 3	3B	0.360 2	0.371 7	0.391 1	0.395 7	0.004 6	0.437 5
7/16 — 16	UN	2A	0.001 4	0.436 1	0.426 7	0.395 5	0.390 9	0.004 6	0.359 4	0.350 3	2B	0.369 8	0.383 9	0.396 9	0.402 8	0.005 9	0.437 5
		3A	0.000 0	0.437 5	0.428 1	0.396 9	0.393 5	0.003 4	0.360 8	0.352 9	3B	0.369 8	0.380 0	0.396 9	0.400 9	0.004 0	0.437 5
7/16 — 20	UNF	1A	0.001 3	0.436 2	0.424 0	0.403 7	0.397 5	0.006 2	0.374 9	0.365 1	1B	0.383 4	0.394 9	0.405 0	0.413 1	0.008 1	0.437 5
		2A	0.001 3	0.436 2	0.428 1	0.403 7	0.399 5	0.004 2	0.374 9	0.367 1	2B	0.383 4	0.394 9	0.405 0	0.410 4	0.005 4	0.437 5
		3A	0.000 0	0.437 5	0.429 4	0.405 0	0.401 9	0.003 1	0.376 2	0.369 5	3B	0.383 4	0.391 6	0.405 0	0.409 1	0.004 1	0.437 5
7/16 — 28	UNEF	2A	0.001 1	0.436 4	0.429 9	0.413 2	0.409 6	0.003 6	0.392 6	0.386 4	2B	0.398 8	0.407 2	0.414 3	0.418 9	0.004 6	0.437 5
		3A	0.000 0	0.437 5	0.431 0	0.414 3	0.411 6	0.002 7	0.393 7	0.388 4	3B	0.398 8	0.405 1	0.414 3	0.417 8	0.003 5	0.437 5
7/16 — 32	UN	2A	0.001 0	0.436 5	0.430 5	0.416 2	0.412 8	0.003 4	0.398 2	0.392 6	2B	0.403 7	0.411 1	0.417 2	0.421 6	0.004 4	0.437 5
		3A	0.000 0	0.437 5	0.431 5	0.417 2	0.414 7	0.002 5	0.399 2	0.394 5	3B	0.403 7	0.409 4	0.417 2	0.420 5	0.003 3	0.437 5
1/2 — 13	UNC	1A	0.001 5	0.498 5	0.482 2	0.448 5	0.441 1	0.007 4	0.404 1	0.391 1	1B	0.416 7	0.433 6	0.450 0	0.459 7	0.009 7	0.500 0
		2A	0.001 5	0.498 5	0.487 6	0.448 5	0.443 5	0.005 0	0.404 1	0.393 6	2B	0.416 7	0.433 6	0.450 0	0.456 5	0.006 5	0.500 0
		3A	0.000 0	0.500 0	0.489 1	0.450 0	0.446 3	0.003 7	0.405 6	0.396 3	3B	0.416 7	0.428 4	0.450 0	0.454 8	0.004 8	0.500 0
1/2 — 16	UN	2A	0.001 4	0.498 6	0.489 2	0.458 0	0.453 3	0.004 7	0.421 9	0.412 7	2B	0.432 3	0.446 4	0.459 4	0.465 5	0.006 1	0.500 0
		3A	0.000 0	0.500 0	0.490 6	0.459 4	0.455 9	0.003 5	0.423 3	0.415 3	3B	0.432 3	0.441 9	0.459 4	0.464 0	0.004 6	0.500 0
1/2 — 20	UNF	1A	0.001 3	0.498 7	0.486 5	0.466 2	0.459 8	0.006 4	0.437 4	0.427 4	1B	0.445 9	0.457 4	0.467 5	0.475 9	0.008 4	0.500 0
		2A	0.001 3	0.498 7	0.490 6	0.466 2	0.461 9	0.004 3	0.437 4	0.429 5	2B	0.445 9	0.457 4	0.467 5	0.473 1	0.005 6	0.500 0
		3A	0.000 0	0.500 0	0.491 9	0.467 5	0.464 3	0.003 2	0.458 7	0.431 9	3B	0.445 9	0.453 7	0.467 5	0.471 7	0.004 2	0.500 0
1/2 — 28	UNEF	2A	0.001 1	0.498 9	0.492 4	0.475 7	0.472 0	0.003 7	0.455 1	0.448 8	2B	0.461 3	0.469 7	0.476 8	0.481 6	0.004 8	0.500 0
		3A	0.000 0	0.500 0	0.493 5	0.476 8	0.474 0	0.002 8	0.456 2	0.450 8	3B	0.461 3	0.467 6	0.476 8	0.480 4	0.003 6	0.500 0
1/2 — 32	UN	2A	0.001 0	0.499 0	0.493 0	0.478 7	0.475 2	0.003 5	0.460 7	0.455 0	2B	0.466 2	0.473 6	0.479 7	0.484 2	0.004 5	0.500 0
		3A	0.000 0	0.500 0	0.494 0	0.479 7	0.477 1	0.002 6	0.461 7	0.456 9	3B	0.466 2	0.471 9	0.479 7	0.483 1	0.003 4	0.500 0
9/16 — 12	UNC	1A	0.001 6	0.560 9	0.543 7	0.506 8	0.499 0	0.007 8	0.458 7	0.444 9	1B	0.472 3	0.490 4	0.508 4	0.518 6	0.010 2	0.562 5
		2A	0.001 6	0.560 9	0.549 5	0.506 8	0.501 6	0.005 2	0.458 7	0.447 5	2B	0.472 3	0.490 4	0.508 4	0.515 2	0.006 8	0.562 5
		3A	0.000 0	0.562 5	0.551 1	0.508 4	0.504 5	0.003 9	0.460 3	0.450 4	3B	0.472 3	0.484 3	0.508 4	0.513 5	0.005 1	0.562 5

Table 2 Unified screw threads, standard series – Limits of size (continued)

1	2	3	4	5	6	7	8	9	10	11	12	13	14	15	16	17	18
Nominal size and threads per inch	Series designation	External threads									Internal threads						
		Class	Allowance	Major diameter		Effective diameter			Minor diameter		Class	Minor diameter		Effective diameter			Major diameter
				Max.	Min.	Max.	Min.	Tol.	Max.	Min.		Min.	Max.	Min.	Max.	Tol.	
				in	in	in	in	in	in	in		in	in	in	in	in	
1/16 — 16	UN	2A	0.001 4	0.561 1	0.551 7	0.520 5	0.515 8	0.004 7	0.484 4	0.475 2	2B	0.494 8	0.508 9	0.521 9	0.528 0	0.006 1	0.562 5
		3A	0.000 0	0.562 5	0.553 1	0.521 9	0.518 4	0.003 5	0.485 8	0.477 8	3B	0.494 8	0.504 0	0.521 9	0.526 5	0.004 6	0.562 5
9/16 — 18	UNF	1A	0.001 4	0.561 1	0.548 0	0.525 0	0.518 2	0.006 8	0.492 9	0.482 1	1B	0.502 4	0.515 1	0.526 4	0.535 3	0.008 9	0.562 5
		2A	0.001 4	0.561 1	0.552 4	0.525 0	0.520 5	0.004 5	0.492 9	0.484 4	2B	0.502 4	0.515 1	0.526 4	0.532 3	0.005 9	0.562 5
		3A	0.000 0	0.562 5	0.553 8	0.526 4	0.523 0	0.003 4	0.494 3	0.486 9	3B	0.502 4	0.510 6	0.526 4	0.530 8	0.004 4	0.562 5
9/16 — 20	UN	2A	0.001 3	0.561 2	0.553 1	0.528 7	0.524 5	0.004 2	0.499 9	0.492 1	2B	0.508 4	0.519 9	0.530 0	0.535 5	0.005 5	0.562 5
		3A	0.000 0	0.562 5	0.554 4	0.530 0	0.526 8	0.003 2	0.501 2	0.494 4	3B	0.508 4	0.516 2	0.530 0	0.534 1	0.004 1	0.562 5
9/16 — 24	UNEF	2A	0.001 2	0.561 3	0.554 1	0.534 2	0.530 3	0.003 9	0.510 2	0.503 3	2B	0.517 4	0.527 1	0.535 4	0.540 5	0.005 1	0.562 5
		3A	0.000 0	0.562 5	0.555 3	0.535 4	0.532 5	0.002 9	0.511 4	0.505 5	3B	0.517 4	0.524 4	0.535 4	0.539 2	0.003 8	0.562 5
9/16 — 28	UN	2A	0.001 1	0.561 4	0.554 9	0.538 2	0.534 5	0.003 7	0.517 6	0.511 3	2B	0.523 8	0.532 2	0.539 3	0.544 1	0.004 8	0.562 5
		3A	0.000 0	0.562 5	0.556 0	0.539 3	0.536 5	0.002 8	0.518 7	0.513 3	3B	0.523 8	0.530 1	0.539 3	0.542 9	0.003 6	0.562 5
9/16 — 32	UN	2A	0.001 0	0.561 5	0.555 5	0.541 2	0.537 7	0.003 5	0.523 2	0.517 5	2B	0.528 7	0.536 1	0.542 2	0.546 7	0.004 5	0.562 5
		3A	0.000 0	0.562 5	0.556 5	0.542 2	0.539 6	0.002 6	0.524 2	0.519 4	3B	0.528 7	0.534 4	0.542 2	0.545 6	0.003 4	0.562 5
5/64 — 11	UNC	1A	0.001 6	0.623 4	0.605 2	0.564 4	0.556 1	0.008 3	0.511 9	0.497 1	1B	0.526 6	0.546 0	0.566 0	0.576 7	0.010 7	0.625 0
		2A	0.001 6	0.623 4	0.611 3	0.564 4	0.558 9	0.005 5	0.511 9	0.499 9	2B	0.526 6	0.546 0	0.566 0	0.573 2	0.007 2	0.625 0
		3A	0.000 0	0.625 0	0.612 9	0.566 0	0.561 9	0.004 1	0.513 5	0.502 9	3B	0.526 6	0.539 1	0.566 0	0.571 4	0.005 4	0.625 0
5/8 — 12	UN	2A	0.001 6	0.623 4	0.612 0	0.569 3	0.563 9	0.005 4	0.521 2	0.509 8	2B	0.534 8	0.552 9	0.570 9	0.578 0	0.007 1	0.625 0
		3A	0.000 0	0.625 0	0.613 6	0.570 9	0.566 8	0.004 1	0.522 8	0.512 7	3B	0.534 8	0.546 3	0.570 9	0.576 2	0.005 3	0.625 0
5/8 — 16	UN	2A	0.001 4	0.623 6	0.614 2	0.583 0	0.578 2	0.004 8	0.546 9	0.537 6	2B	0.557 3	0.571 4	0.584 4	0.590 6	0.006 2	0.625 0
		3A	0.000 0	0.625 0	0.615 6	0.584 4	0.580 8	0.003 6	0.548 3	0.540 2	3B	0.557 3	0.566 2	0.584 4	0.589 0	0.004 6	0.625 0
5/8 — 18	UNF	1A	0.001 4	0.623 6	0.610 5	0.587 5	0.580 5	0.007 0	0.555 4	0.544 4	1B	0.564 9	0.577 6	0.588 9	0.598 0	0.009 1	0.625 0
		2A	0.001 4	0.623 6	0.614 9	0.587 5	0.582 8	0.004 7	0.555 4	0.546 7	2B	0.564 9	0.577 6	0.588 9	0.594 9	0.006 0	0.625 0
		3A	0.000 0	0.625 0	0.616 3	0.588 9	0.585 4	0.003 5	0.556 8	0.549 3	3B	0.564 9	0.573 0	0.588 9	0.593 4	0.004 5	0.625 0
5/64 — 20	UN	2A	0.001 3	0.623 7	0.615 6	0.591 2	0.586 9	0.004 3	0.562 4	0.554 5	2B	0.570 9	0.582 4	0.592 5	0.598 1	0.005 6	0.625 0
		3A	0.000 0	0.625 0	0.616 9	0.592 5	0.589 3	0.003 2	0.563 7	0.556 9	3B	0.570 9	0.578 7	0.592 5	0.596 7	0.004 2	0.625 0
5/8 — 24	UNEF	2A	0.001 2	0.623 8	0.616 6	0.596 7	0.592 7	0.004 0	0.572 7	0.565 7	2B	0.579 9	0.589 6	0.597 9	0.603 1	0.005 2	0.625 0
		3A	0.000 0	0.625 0	0.617 8	0.597 9	0.594 9	0.003 0	0.573 9	0.567 9	3B	0.579 9	0.586 9	0.597 9	0.601 8	0.003 9	0.625 0
5/8 — 28	UN	2A	0.001 1	0.623 9	0.617 4	0.600 7	0.596 9	0.003 8	0.580 1	0.573 7	2B	0.586 3	0.594 7	0.601 8	0.606 7	0.004 9	0.625 0
		3A	0.000 0	0.625 0	0.618 5	0.601 8	0.599 0	0.002 8	0.581 2	0.575 8	3B	0.586 3	0.592 6	0.601 8	0.605 5	0.003 7	0.625 0

Table 2 Unified screw threads, standard series – Limits of size (continued)

1	2	3	4	5	6	7	8	9	10	11	12	13	14	15	16	17	18
Nominal size and threads per inch	Series designation	External threads									Internal threads						
		Class	Allowance in	Major diameter		Effective diameter			Minor diameter		Class	Minor diameter		Effective diameter			Major diameter
				Max.	Min.	Max.	Min.	Tol.	Max.	Min.		Min.	Max.	Min.	Max.	Tol.	Min.
				in	in	in	in	in	in	in		in	in	in	in	in	in
5/8 — 32	UN	2A	0.001 1	0.623 9	0.617 9	0.603 6	0.600 0	0.003 6	0.585 6	0.579 8	2B	0.591 2	0.598 6	0.604 7	0.609 3	0.004 6	0.625 0
		3A	0.000 0	0.625 0	0.619 0	0.604 7	0.602 0	0.002 7	0.586 7	0.581 8	3B	0.591 2	0.596 9	0.604 7	0.608 2	0.003 5	0.625 0
11/16 — 12	UN	2A	0.001 6	0.685 9	0.674 5	0.631 8	0.626 4	0.005 4	0.583 7	0.572 3	2B	0.597 3	0.615 4	0.633 4	0.640 5	0.007 1	0.687 5
		3A	0.000 0	0.687 5	0.676 1	0.633 4	0.629 3	0.004 1	0.585 3	0.575 2	3B	0.597 3	0.608 5	0.633 4	0.638 7	0.005 3	0.687 5
11/16 — 16	UN	2A	0.001 4	0.686 1	0.676 7	0.645 5	0.640 7	0.004 8	0.609 4	0.600 1	2B	0.619 8	0.633 9	0.646 9	0.653 1	0.006 2	0.687 5
		3A	0.000 0	0.687 5	0.678 1	0.646 9	0.643 3	0.003 6	0.610 8	0.602 7	3B	0.619 8	0.628 4	0.646 9	0.651 5	0.004 6	0.687 5
11/16 — 20	UN	2A	0.001 3	0.686 2	0.678 1	0.653 7	0.649 4	0.004 3	0.624 9	0.617 0	2B	0.633 4	0.644 9	0.655 0	0.660 6	0.005 6	0.687 5
		3A	0.000 0	0.687 5	0.679 4	0.655 0	0.651 8	0.003 2	0.626 2	0.619 4	3B	0.633 4	0.641 2	0.655 0	0.659 2	0.004 2	0.687 5
11/16 — 24	UNEF	2A	0.001 2	0.686 3	0.679 1	0.659 2	0.655 2	0.004 0	0.635 2	0.628 2	2B	0.642 4	0.652 1	0.660 4	0.665 6	0.005 2	0.687 5
		3A	0.000 0	0.687 5	0.680 3	0.660 4	0.657 4	0.003 0	0.636 4	0.630 4	3B	0.642 4	0.649 4	0.660 4	0.664 3	0.003 9	0.687 5
11/16 — 28	UN	2A	0.001 1	0.686 4	0.679 9	0.663 2	0.659 4	0.003 8	0.642 6	0.636 2	2B	0.648 8	0.657 2	0.664 3	0.669 2	0.004 9	0.687 5
		3A	0.000 0	0.687 5	0.681 0	0.664 3	0.661 5	0.002 8	0.643 7	0.638 3	3B	0.648 8	0.655 1	0.664 3	0.668 0	0.003 7	0.687 5
11/16 — 32	UN	2A	0.001 1	0.686 4	0.680 4	0.666 1	0.662 5	0.003 6	0.648 1	0.642 3	2B	0.653 7	0.661 1	0.667 2	0.671 8	0.004 6	0.687 5
		3A	0.000 0	0.687 5	0.681 5	0.667 2	0.664 5	0.002 7	0.649 2	0.644 3	3B	0.653 7	0.659 4	0.667 2	0.670 7	0.003 5	0.687 5
3/4 — 10	UNC	1A	0.001 8	0.748 2	0.728 8	0.683 2	0.674 4	0.008 8	0.625 5	0.609 5	1B	0.641 7	0.662 7	0.685 0	0.696 5	0.011 5	0.750 0
		2A	0.001 8	0.748 2	0.735 3	0.683 2	0.677 3	0.005 9	0.625 5	0.612 4	2B	0.641 7	0.662 7	0.685 0	0.692 7	0.007 7	0.750 0
		3A	0.000 0	0.750 0	0.737 1	0.685 0	0.680 6	0.004 4	0.627 3	0.615 7	3B	0.641 7	0.654 5	0.685 0	0.690 7	0.005 7	0.750 0
3/4 — 12	UN	2A	0.001 7	0.748 3	0.736 9	0.694 2	0.688 7	0.005 5	0.646 1	0.634 6	2B	0.659 8	0.677 9	0.695 9	0.703 1	0.007 2	0.750 0
		3A	0.000 0	0.750 0	0.738 6	0.695 9	0.691 8	0.004 1	0.647 8	0.637 7	3B	0.659 8	0.670 7	0.695 9	0.701 3	0.005 4	0.750 0
3/4 — 16	UNF	1A	0.001 5	0.748 5	0.734 3	0.707 9	0.700 4	0.007 5	0.671 8	0.659 8	1B	0.682 3	0.696 4	0.709 4	0.719 2	0.009 8	0.750 0
		2A	0.001 5	0.748 5	0.739 1	0.707 9	0.702 9	0.005 0	0.671 8	0.662 3	2B	0.682 3	0.696 4	0.709 4	0.715 9	0.006 5	0.750 0
		3A	0.000 0	0.750 0	0.740 6	0.709 4	0.705 6	0.003 8	0.673 3	0.665 0	3B	0.682 3	0.690 8	0.709 4	0.714 3	0.004 9	0.750 0
3/4 — 20	UNEF	2A	0.001 3	0.748 7	0.740 6	0.716 2	0.711 8	0.004 4	0.687 4	0.679 4	2B	0.695 9	0.707 4	0.717 5	0.723 2	0.005 7	0.750 0
		3A	0.000 0	0.750 0	0.741 9	0.717 5	0.714 2	0.003 3	0.688 7	0.681 8	3B	0.695 9	0.703 7	0.717 5	0.721 8	0.004 3	0.750 0
3/4 — 28	UN	2A	0.001 2	0.748 8	0.742 3	0.725 6	0.721 8	0.003 8	0.705 0	0.698 6	2B	0.711 3	0.719 7	0.726 8	0.731 8	0.005 0	0.750 0
		3A	0.000 0	0.750 0	0.743 5	0.726 8	0.723 9	0.002 9	0.706 2	0.700 7	3B	0.711 3	0.717 6	0.726 8	0.730 5	0.003 7	0.750 0
3/4 — 32	UN	2A	0.001 1	0.748 9	0.742 9	0.728 6	0.725 0	0.003 6	0.710 6	0.704 8	2B	0.716 2	0.723 6	0.729 7	0.734 4	0.004 7	0.750 0
		3A	0.000 0	0.750 0	0.744 0	0.729 7	0.727 0	0.002 7	0.711 7	0.706 8	3B	0.716 2	0.721 9	0.729 7	0.733 3	0.003 6	0.750 0

Table 2 Unified screw threads, standard series – Limits of size (continued)

1	2	3	4	5	6	7	8	9	10	11	12	13	14	15	16	17	18
Nominal size and threads per inch	Series designation	External threads									Internal threads						
		Class	Allowance	Major diameter		Effective diameter			Minor diameter		Class	Minor diameter		Effective diameter			Major diameter
				Max.	Min.	Max.	Min.	Tol.	Max.	Min.		Min.	Max.	Min.	Max.	Tol.	
				in	in	in	in	in	in	in		in	in	in	in	in	
1/16 — 12	UN	2A	0.001 7	0.810 8	0.799 4	0.756 7	0.751 2	0.005 5	0.708 6	0.697 1	2B	0.722 3	0.740 4	0.758 4	0.765 6	0.007 2	0.812 5
		3A	0.000 0	0.812 5	0.801 1	0.758 4	0.754 3	0.004 1	0.710 3	0.700 2	3B	0.722 3	0.732 9	0.758 4	0.763 8	0.005 4	0.812 5
1/16 — 16	UN	2A	0.001 5	0.811 0	0.801 6	0.770 4	0.765 5	0.004 9	0.734 3	0.724 9	2B	0.744 8	0.758 9	0.771 9	0.778 2	0.006 3	0.812 5
		3A	0.000 0	0.812 5	0.803 1	0.771 9	0.768 3	0.003 6	0.735 8	0.727 7	3B	0.744 8	0.753 3	0.771 9	0.776 6	0.004 7	0.812 5
1/16 — 20	UNEF	2A	0.001 3	0.811 2	0.803 1	0.778 7	0.774 3	0.004 4	0.749 8	0.741 8	2B	0.758 4	0.769 9	0.780 0	0.785 7	0.005 7	0.812 5
		3A	0.000 0	0.812 5	0.804 4	0.780 0	0.776 7	0.003 3	0.751 2	0.744 3	3B	0.758 4	0.766 2	0.780 0	0.784 3	0.004 3	0.812 5
1/16 — 28	UN	2A	0.001 2	0.811 3	0.804 8	0.788 1	0.784 3	0.003 8	0.767 5	0.761 1	2B	0.773 8	0.782 2	0.789 3	0.794 3	0.005 0	0.812 5
		3A	0.000 0	0.812 5	0.806 0	0.789 3	0.786 4	0.002 9	0.768 7	0.763 2	3B	0.773 8	0.780 1	0.789 3	0.793 0	0.003 7	0.812 5
1/16 — 32	UN	2A	0.001 1	0.811 4	0.805 4	0.791 1	0.787 5	0.003 6	0.773 1	0.767 3	2B	0.778 7	0.786 1	0.792 2	0.796 9	0.004 7	0.812 5
		3A	0.000 0	0.812 5	0.806 5	0.792 2	0.789 5	0.002 7	0.774 2	0.769 3	3B	0.778 7	0.784 4	0.792 2	0.795 8	0.003 6	0.812 5
7/8 — 9	UNC	1A	0.001 9	0.873 1	0.852 3	0.800 9	0.791 4	0.009 5	0.736 8	0.719 3	1B	0.754 7	0.777 5	0.802 8	0.815 1	0.012 3	0.875 0
		2A	0.001 9	0.873 1	0.859 2	0.800 9	0.794 6	0.006 3	0.736 8	0.722 5	2B	0.754 7	0.777 5	0.802 8	0.811 0	0.008 2	0.875 0
		3A	0.000 0	0.875 0	0.861 1	0.802 8	0.798 1	0.004 7	0.738 7	0.726 0	3B	0.754 7	0.768 5	0.802 8	0.808 9	0.006 1	0.875 0
7/8 — 12	UN	2A	0.001 7	0.873 3	0.861 9	0.819 2	0.813 7	0.005 5	0.771 1	0.759 6	2B	0.784 8	0.802 9	0.820 9	0.828 1	0.007 2	0.875 0
		3A	0.000 0	0.875 0	0.863 6	0.820 9	0.816 8	0.004 1	0.772 8	0.762 7	3B	0.784 8	0.795 2	0.820 9	0.826 3	0.005 4	0.875 0
7/8 — 14	UNF	1A	0.001 6	0.873 4	0.857 9	0.827 0	0.818 9	0.008 1	0.785 8	0.772 6	1B	0.797 7	0.813 5	0.828 6	0.839 2	0.010 6	0.875 0
		2A	0.001 6	0.873 4	0.863 1	0.827 0	0.821 6	0.005 4	0.785 8	0.775 3	2B	0.797 7	0.813 5	0.828 6	0.835 6	0.007 0	0.875 0
		3A	0.000 0	0.875 0	0.864 7	0.828 6	0.824 5	0.004 1	0.787 4	0.778 2	3B	0.797 7	0.806 8	0.828 6	0.833 9	0.005 3	0.875 0
7/8 — 16	UN	2A	0.001 5	0.873 5	0.864 1	0.832 9	0.828 0	0.004 9	0.796 8	0.787 4	2B	0.807 3	0.821 4	0.834 4	0.840 7	0.006 3	0.875 0
		3A	0.000 0	0.875 0	0.865 6	0.834 4	0.830 8	0.003 6	0.798 3	0.790 2	3B	0.807 3	0.815 8	0.834 4	0.839 1	0.004 7	0.875 0
7/8 — 20	UNEF	2A	0.001 3	0.873 7	0.865 6	0.841 2	0.836 8	0.004 4	0.812 4	0.804 4	2B	0.820 9	0.832 4	0.842 5	0.848 2	0.005 7	0.875 0
		3A	0.000 0	0.875 0	0.866 9	0.842 5	0.839 2	0.003 3	0.813 7	0.806 8	3B	0.820 9	0.828 7	0.842 5	0.846 8	0.004 3	0.875 0
7/8 — 28	UN	2A	0.001 2	0.873 8	0.867 3	0.850 6	0.846 8	0.003 8	0.830 0	0.823 6	2B	0.836 3	0.844 7	0.851 8	0.856 8	0.005 0	0.875 0
		3A	0.000 0	0.875 0	0.868 5	0.851 8	0.848 9	0.002 9	0.831 2	0.825 7	3B	0.836 3	0.842 6	0.851 8	0.855 5	0.003 7	0.875 0
7/8 — 32	UN	2A	0.001 1	0.873 9	0.867 9	0.853 6	0.850 0	0.003 6	0.835 6	0.829 8	2B	0.841 2	0.848 6	0.854 7	0.859 4	0.004 7	0.875 0
		3A	0.000 0	0.875 0	0.869 0	0.854 7	0.852 0	0.002 7	0.836 7	0.831 8	3B	0.841 2	0.846 9	0.854 7	0.858 3	0.003 6	0.875 0
15/16 — 12	UN	2A	0.001 7	0.935 8	0.924 4	0.881 7	0.876 0	0.005 7	0.833 6	0.821 9	2B	0.847 3	0.865 4	0.883 4	0.890 8	0.007 4	0.937 5
		3A	0.000 0	0.937 5	0.926 1	0.883 4	0.879 3	0.004 1	0.835 3	0.825 2	3B	0.847 3	0.857 5	0.883 4	0.888 9	0.005 5	0.937 5

Table 2 Unified screw threads, standard series – Limits of size (continued)

1	2	3	4	5	6	7	8	9	10	11	12	13	14	15	16	17	18
Nominal size and threads per inch	Series designation	External threads									Internal threads						
		Class	Allowance in	Major diameter		Effective diameter			Minor diameter		Class	Minor diameter		Effective diameter			Major diameter in
				Max.	Min.	Max.	Min.	Tol.	Max.	Min.		Min.	Max.	Min.	Max.	Tol.	
				in	in	in	in	in	in	in		in	in	in	in	in	
15/16 — 16	UN	2A	0.001 5	0.936 0	0.926 6	0.895 4	0.890 4	0.005 0	0.859 3	0.849 8	2B	0.869 8	0.883 9	0.896 9	0.903 4	0.006 5	0.937 5
		3A	0.000 0	0.937 5	0.928 1	0.896 9	0.893 2	0.003 7	0.860 8	0.852 6	3B	0.869 8	0.878 3	0.896 9	0.901 8	0.004 9	0.937 5
15/16 — 20	UNEF	2A	0.001 4	0.936 1	0.928 0	0.903 6	0.899 1	0.004 5	0.874 8	0.866 7	2B	0.883 4	0.894 9	0.905 0	0.910 9	0.005 9	0.937 5
		3A	0.000 0	0.937 5	0.929 4	0.905 0	0.901 6	0.003 4	0.876 2	0.869 2	3B	0.883 4	0.891 2	0.905 0	0.909 4	0.004 4	0.937 5
15/16 — 28	UN	2A	0.001 2	0.936 3	0.929 8	0.913 1	0.909 1	0.004 0	0.892 5	0.885 9	2B	0.898 8	0.907 2	0.914 3	0.919 5	0.005 2	0.937 5
		3A	0.000 0	0.937 5	0.931 0	0.914 3	0.911 3	0.003 0	0.893 7	0.888 1	3B	0.898 8	0.905 1	0.914 3	0.918 2	0.003 9	0.937 5
15/16 — 32	UN	2A	0.001 1	0.936 4	0.930 4	0.916 1	0.912 3	0.003 8	0.898 1	0.892 1	2B	0.903 7	0.911 1	0.917 2	0.922 1	0.004 9	0.937 5
		3A	0.000 0	0.937 5	0.931 5	0.917 2	0.914 4	0.002 8	0.899 2	0.894 2	3B	0.903 7	0.909 4	0.917 2	0.920 9	0.003 7	0.937 5
1 — 8	UNC	1A	0.002 0	0.998 0	0.975 5	0.916 8	0.906 7	0.010 1	0.844 6	0.825 5	1B	0.864 7	0.889 7	0.918 8	0.932 0	0.013 2	1.000 0
		2A	0.002 0	0.998 0	0.983 0	0.916 8	0.910 0	0.006 8	0.844 6	0.828 8	2B	0.864 7	0.889 7	0.918 8	0.927 6	0.008 8	1.000 0
		3A	0.000 0	1.000 0	0.985 0	0.918 8	0.913 7	0.005 1	0.846 6	0.832 5	3B	0.864 7	0.879 7	0.918 8	0.925 4	0.006 6	1.000 0
1 — 12	UNF	1A	0.001 8	0.998 2	0.981 0	0.944 1	0.935 3	0.008 8	0.896 0	0.881 2	1B	0.909 8	0.927 9	0.945 9	0.957 3	0.011 4	1.000 0
		2A	0.001 8	0.998 2	0.986 8	0.944 1	0.938 2	0.005 9	0.896 0	0.884 1	2B	0.909 8	0.927 9	0.945 9	0.953 5	0.007 6	1.000 0
		3A	0.000 0	1.000 0	0.988 6	0.945 9	0.941 5	0.004 4	0.897 8	0.887 4	3B	0.909 8	0.919 8	0.945 9	0.951 6	0.005 7	1.000 0
1 — 16	UN	2A	0.001 5	0.998 5	0.989 1	0.957 9	0.952 9	0.005 0	0.921 8	0.912 3	2B	0.932 3	0.946 4	0.959 4	0.965 9	0.006 5	1.000 0
		3A	0.000 0	1.000 0	0.990 6	0.959 4	0.955 7	0.003 7	0.923 3	0.915 1	3B	0.932 3	0.940 8	0.959 4	0.964 3	0.004 9	1.000 0
1 — 20	UNEF	2A	0.001 4	0.998 6	0.990 5	0.966 1	0.961 6	0.004 5	0.937 3	0.929 2	2B	0.945 9	0.957 4	0.967 5	0.973 4	0.005 9	1.000 0
		3A	0.000 0	1.000 0	0.991 9	0.967 5	0.964 1	0.003 4	0.938 7	0.931 7	3B	0.945 9	0.953 7	0.967 5	0.971 9	0.004 4	1.000 0
1 — 28	UN	2A	0.001 2	0.998 8	0.992 3	0.975 6	0.971 6	0.004 0	0.955 0	0.948 4	2B	0.961 3	0.969 7	0.976 8	0.982 0	0.005 2	1.000 0
		3A	0.000 0	1.000 0	0.993 5	0.976 8	0.973 8	0.003 0	0.956 2	0.950 6	3B	0.961 3	0.967 6	0.976 8	0.980 7	0.003 9	1.000 0
1 — 32	UN	2A	0.001 1	0.998 9	0.992 9	0.978 6	0.974 8	0.003 8	0.960 6	0.954 6	2B	0.966 2	0.973 6	0.979 7	0.984 6	0.004 9	1.000 0
		3A	0.000 0	1.000 0	0.994 0	0.979 7	0.976 9	0.002 8	0.961 7	0.956 7	3B	0.966 2	0.971 9	0.979 7	0.983 4	0.003 7	1.000 0
1 1/16 — 8	UN	2A	0.002 0	1.060 5	1.045 5	0.979 3	0.972 5	0.006 8	0.907 1	0.891 3	2B	0.927 2	0.952 2	0.981 3	0.990 2	0.008 9	1.062 5
		3A	0.000 0	1.062 5	1.047 5	0.981 3	0.976 2	0.005 1	0.909 1	0.895 0	3B	0.927 2	0.942 2	0.981 3	0.988 0	0.006 7	1.062 5
1 1/16 — 12	UN	2A	0.001 7	1.060 8	1.049 4	1.006 7	1.001 0	0.005 7	0.958 6	0.946 9	2B	0.972 3	0.990 4	1.008 4	1.015 8	0.007 4	1.062 5
		3A	0.000 0	1.062 5	1.051 1	1.008 4	1.004 2	0.004 2	0.960 3	0.950 1	3B	0.972 3	0.982 3	1.008 4	1.013 9	0.005 5	1.062 5
1 1/16 — 16	UN	2A	0.001 5	1.061 0	1.051 6	1.020 4	1.015 4	0.005 0	0.984 3	0.974 8	2B	0.994 8	1.008 9	1.021 9	1.028 4	0.006 5	1.062 5
		3A	0.000 0	1.062 5	1.053 1	1.021 9	1.018 2	0.003 7	0.985 8	0.977 6	3B	0.994 8	1.003 3	1.021 9	1.026 8	0.004 9	1.062 5

Table 2 Unified screw threads, standard series – Limits of size (continued)

1	2	3	4	5	6	7	8	9	10	11	12	13	14	15	16	17	18
Nominal size and threads per inch	Series designation	External threads									Internal threads						
		Class	Allowance	Major diameter		Effective diameter			Minor diameter		Class	Minor diameter		Effective diameter			Major diameter
				Max.	Min.	Max.	Min.	Tol.	Max.	Min.		Min.	Max.	Min.	Max.	Tol.	Min.
				in	in	in	in	in	in	in		in	in	in	in	in	in
1 ¹ / ₁₆ — 18	UNEF	2A	0.001 4	1.061 1	1.052 4	1.025 0	1.020 3	0.004 7	0.992 9	0.984 2	2B	1.002 4	1.015 1	1.026 4	1.032 6	0.006 2	1.062 5
		3A	0.000 0	1.062 5	1.053 8	1.026 4	1.022 8	0.003 6	0.994 3	0.986 7	3B	1.002 4	1.010 5	1.026 4	1.031 0	0.004 6	1.062 5
1 ¹ / ₁₆ — 20	UN	2A	0.001 4	1.061 1	1.053 0	1.028 6	1.024 1	0.004 5	0.999 8	0.991 7	2B	1.008 4	1.019 9	1.030 0	1.035 9	0.005 9	1.062 5
		3A	0.000 0	1.062 5	1.054 4	1.030 0	1.026 6	0.003 4	1.001 2	0.994 2	3B	1.008 4	1.016 2	1.030 0	1.034 4	0.004 4	1.062 5
1 ¹ / ₁₆ — 28	UN	2A	0.001 2	1.061 3	1.054 8	1.038 1	1.034 1	0.004 0	1.017 5	1.010 9	2B	1.023 8	1.032 2	1.039 3	1.044 5	0.005 2	1.062 5
		3A	0.000 0	1.062 5	1.056 0	1.039 3	1.036 3	0.003 0	1.018 7	1.013 1	3B	1.023 8	1.030 1	1.039 3	1.043 2	0.003 9	1.062 5
1 ¹ / ₈ — 7	UNC	1A	0.002 2	1.122 8	1.098 2	1.030 0	1.019 1	0.010 9	0.947 5	0.926 3	1B	0.970 4	0.998 0	1.032 2	1.046 3	0.014 1	1.125 0
		2A	0.002 2	1.122 8	1.106 4	1.030 0	1.022 8	0.007 2	0.947 5	0.930 0	2B	0.970 4	0.998 0	1.032 2	1.041 6	0.009 4	1.125 0
		3A	0.000 0	1.125 0	1.108 6	1.032 2	1.026 8	0.005 4	0.949 7	0.934 0	3B	0.970 4	0.987 5	1.032 2	1.039 3	0.007 1	1.125 0
1 ¹ / ₈ — 8	UN	2A	0.002 1	1.122 9	1.107 9	1.041 7	1.034 8	0.006 9	0.969 5	0.953 6	2B	0.989 7	1.014 7	1.043 8	1.052 8	0.009 0	1.125 0
		3A	0.000 0	1.125 0	1.110 0	1.043 8	1.038 6	0.005 2	0.971 6	0.957 4	3B	0.989 7	1.004 7	1.043 8	1.050 5	0.006 7	1.125 0
1 ¹ / ₈ — 12	UNF	1A	0.001 8	1.123 2	1.106 0	1.069 1	1.060 1	0.009 0	1.021 0	1.006 0	1B	1.034 8	1.052 9	1.070 9	1.082 6	0.011 7	1.125 0
		2A	0.001 8	1.123 2	1.111 8	1.069 1	1.063 1	0.006 0	1.021 0	1.009 0	2B	1.034 8	1.052 9	1.070 9	1.078 7	0.007 8	1.125 0
		3A	0.000 0	1.125 0	1.113 6	1.070 9	1.066 4	0.004 5	1.022 8	1.012 3	3B	1.034 8	1.044 8	1.070 9	1.076 8	0.005 9	1.125 0
1 ¹ / ₈ — 16	UN	2A	0.001 5	1.123 5	1.114 1	1.082 9	1.077 9	0.005 0	1.046 8	1.037 3	2B	1.057 3	1.071 4	1.084 4	1.090 9	0.006 5	1.125 0
		3A	0.000 0	1.125 0	1.115 6	1.084 4	1.080 7	0.003 7	1.048 3	1.040 1	3B	1.057 3	1.065 8	1.084 4	1.089 3	0.004 9	1.125 0
1 ¹ / ₈ — 18	UNEF	2A	0.001 4	1.123 6	1.114 9	1.087 5	1.082 8	0.004 7	1.055 4	1.046 7	2B	1.064 9	1.077 6	1.088 9	1.095 1	0.006 2	1.125 0
		3A	0.000 0	1.125 0	1.116 3	1.088 9	1.085 3	0.003 6	1.056 8	1.049 2	3B	1.064 9	1.073 0	1.088 9	1.093 5	0.004 6	1.125 0
1 ¹ / ₈ — 20	UN	2A	0.001 4	1.123 6	1.115 5	1.091 1	1.086 6	0.004 5	1.062 3	1.054 2	2B	1.070 9	1.082 4	1.092 5	1.098 4	0.005 9	1.125 0
		3A	0.000 0	1.125 0	1.116 9	1.092 5	1.089 1	0.003 4	1.063 7	1.056 7	3B	1.070 9	1.078 7	1.092 5	1.096 9	0.004 4	1.125 0
1 ¹ / ₈ — 28	UN	2A	0.001 2	1.123 8	1.117 3	1.100 6	1.096 6	0.004 0	1.080 0	1.073 4	2B	1.086 3	1.094 7	1.101 8	1.107 0	0.005 2	1.125 0
		3A	0.000 0	1.125 0	1.118 5	1.101 8	1.098 8	0.003 0	1.081 2	1.075 6	3B	1.086 3	1.092 6	1.101 8	1.105 7	0.003 9	1.125 0
1 ³ / ₁₆ — 8	UN	2A	0.002 1	1.185 4	1.170 4	1.104 2	1.097 2	0.007 0	1.032 0	1.016 0	2B	1.052 2	1.077 2	1.106 3	1.115 4	0.009 1	1.187 5
		3A	0.000 0	1.187 5	1.172 5	1.106 3	1.101 1	0.005 2	1.034 1	1.019 9	3B	1.052 2	1.067 2	1.106 3	1.113 1	0.006 8	1.187 5
1 ³ / ₁₆ — 12	UN	2A	0.001 7	1.185 8	1.174 4	1.131 7	1.125 9	0.005 8	1.083 6	1.071 8	2B	1.097 3	1.115 4	1.133 4	1.140 9	0.007 5	1.187 5
		3A	0.000 0	1.187 5	1.176 1	1.133 4	1.129 1	0.004 3	1.085 3	1.075 0	3B	1.097 3	1.107 3	1.133 4	1.139 0	0.005 6	1.187 5
1 ³ / ₁₆ — 16	UN	2A	0.001 5	1.186 0	1.176 6	1.145 4	1.140 3	0.005 1	1.109 3	1.099 7	2B	1.119 8	1.133 9	1.146 9	1.153 5	0.006 6	1.187 5
		3A	0.000 0	1.187 5	1.178 1	1.146 9	1.143 1	0.003 8	1.110 8	1.102 5	3B	1.119 8	1.128 3	1.146 9	1.151 9	0.005 0	1.187 5

Table 2 Unified screw threads, standard series – Limits of size (continued)

1	2	3	4	5	6	7	8	9	10	11	12	13	14	15	16	17	18
Nominal size and threads per inch	Series designation	External threads									Internal threads						
		Class	Allowance	Major diameter		Effective diameter			Minor diameter		Class	Minor diameter		Effective diameter			Major diameter
				Max.	Min.	Max.	Min.	Tol.	Max.	Min.		Min.	Max.	Min.	Max.	Tol.	
				in	in	in	in	in	in	in		in	in	in	in	in	
1 $\frac{3}{16}$ — 18	UNEF	2A	0.001 5	1.186 0	1.177 3	1.149 9	1.145 0	0.004 9	1.117 8	1.108 9	2B	1.127 4	1.140 1	1.151 4	1.157 7	0.006 3	1.187 5
		3A	0.000 0	1.187 5	1.178 8	1.151 4	1.147 8	0.003 6	1.119 3	1.111 7	3B	1.127 4	1.135 5	1.151 4	1.156 1	0.004 7	1.187 5
1 $\frac{3}{16}$ — 20	UN	2A	0.001 4	1.186 1	1.178 0	1.153 6	1.148 9	0.004 7	1.124 8	1.116 5	2B	1.133 4	1.144 9	1.155 0	1.161 1	0.006 1	1.187 5
		3A	0.000 0	1.187 5	1.179 4	1.155 0	1.151 5	0.003 5	1.126 2	1.119 1	3B	1.133 4	1.141 2	1.155 0	1.159 5	0.004 5	1.187 5
1 $\frac{3}{16}$ — 28	UN	2A	0.001 2	1.186 3	1.179 8	1.163 1	1.159 0	0.004 1	1.142 5	1.135 8	2B	1.148 8	1.157 2	1.164 3	1.169 6	0.005 3	1.187 5
		3A	0.000 0	1.187 5	1.181 0	1.164 3	1.161 2	0.003 1	1.143 7	1.138 0	3B	1.148 8	1.155 1	1.164 3	1.168 3	0.004 0	1.187 5
1 $\frac{1}{4}$ — 7	UNC	1A	0.002 2	1.247 8	1.223 2	1.155 0	1.143 9	0.011 1	1.072 5	1.051 1	1B	1.095 4	1.123 0	1.157 2	1.171 6	0.014 4	1.250 0
		2A	0.002 2	1.247 8	1.231 4	1.155 0	1.147 6	0.007 4	1.072 5	1.054 8	2B	1.095 4	1.123 0	1.157 2	1.166 8	0.009 6	1.250 0
		3A	0.000 0	1.250 0	1.233 6	1.157 2	1.151 7	0.005 5	1.074 7	1.058 9	3B	1.095 4	1.112 5	1.157 2	1.164 4	0.007 2	1.250 0
1 $\frac{1}{4}$ — 8	UN	2A	0.002 1	1.247 9	1.232 9	1.166 7	1.159 7	0.007 0	1.094 5	1.078 5	2B	1.114 7	1.139 7	1.168 8	1.178 0	0.009 2	1.250 0
		3A	0.000 0	1.250 0	1.235 0	1.168 8	1.163 5	0.005 3	1.096 6	1.082 3	3B	1.114 7	1.129 7	1.168 8	1.175 7	0.006 9	1.250 0
1 $\frac{1}{4}$ — 12	UNF	1A	0.001 8	1.248 2	1.231 0	1.194 1	1.184 9	0.009 2	1.146 0	1.130 8	1B	1.159 8	1.177 9	1.195 9	1.207 9	0.012 0	1.250 0
		2A	0.001 8	1.248 2	1.236 8	1.194 1	1.187 9	0.006 2	1.146 0	1.133 8	2B	1.159 8	1.177 9	1.195 9	1.203 9	0.008 0	1.250 0
		3A	0.000 0	1.250 0	1.238 6	1.195 9	1.191 3	0.004 6	1.147 8	1.137 2	3B	1.159 8	1.169 8	1.195 9	1.201 9	0.006 0	1.250 0
1 $\frac{1}{4}$ — 16	UN	2A	0.001 5	1.248 5	1.239 1	1.207 9	1.202 8	0.005 1	1.171 8	1.162 2	2B	1.182 3	1.196 4	1.209 4	1.216 0	0.006 6	1.250 0
		3A	0.000 0	1.250 0	1.240 6	1.209 4	1.205 6	0.003 8	1.173 3	1.165 0	3B	1.182 3	1.190 8	1.209 4	1.214 4	0.005 0	1.250 0
1 $\frac{1}{4}$ — 18	UNEF	2A	0.001 5	1.248 5	1.239 8	1.212 4	1.207 5	0.004 9	1.180 3	1.171 4	2B	1.189 9	1.202 6	1.213 9	1.220 2	0.006 3	1.250 0
		3A	0.000 0	1.250 0	1.241 3	1.213 9	1.210 3	0.003 6	1.181 8	1.174 2	3B	1.189 9	1.198 0	1.213 9	1.218 6	0.004 7	1.250 0
1 $\frac{1}{4}$ — 20	UN	2A	0.001 4	1.248 6	1.240 5	1.216 1	1.211 4	0.004 7	1.187 3	1.179 0	2B	1.195 9	1.207 4	1.217 5	1.223 6	0.006 1	1.250 0
		3A	0.000 0	1.250 0	1.241 9	1.217 5	1.214 0	0.003 5	1.188 7	1.181 6	3B	1.195 9	1.203 7	1.217 5	1.222 0	0.004 5	1.250 0
1 $\frac{1}{4}$ — 28	UN	2A	0.001 2	1.248 8	1.242 3	1.225 6	1.221 5	0.004 1	1.205 0	1.198 3	2B	1.211 3	1.219 7	1.226 8	1.232 1	0.005 3	1.250 0
		3A	0.000 0	1.250 0	1.243 5	1.226 8	1.223 7	0.003 1	1.206 2	1.200 5	3B	1.211 3	1.217 6	1.226 8	1.230 8	0.004 0	1.250 0
1 $\frac{5}{16}$ — 8	UN	2A	0.002 1	1.310 4	1.295 4	1.229 2	1.222 1	0.007 1	1.157 0	1.140 9	2B	1.177 2	1.202 2	1.231 3	1.240 5	0.009 2	1.312 5
		3A	0.000 0	1.312 5	1.297 5	1.231 3	1.226 0	0.005 3	1.159 1	1.144 8	3B	1.177 2	1.192 2	1.231 3	1.238 2	0.006 9	1.312 5
1 $\frac{5}{16}$ — 12	UN	2A	0.001 7	1.310 8	1.299 4	1.256 7	1.250 9	0.005 8	1.208 6	1.196 8	2B	1.222 3	1.240 4	1.258 4	1.265 9	0.007 5	1.312 5
		3A	0.000 0	1.312 5	1.301 1	1.258 4	1.254 1	0.004 3	1.210 3	1.200 0	3B	1.222 3	1.232 3	1.258 4	1.264 0	0.005 6	1.312 5
1 $\frac{5}{16}$ — 16	UN	2A	0.001 5	1.311 0	1.301 6	1.270 4	1.265 3	0.005 1	1.234 3	1.224 7	2B	1.244 8	1.258 9	1.271 9	1.278 5	0.006 6	1.312 5
		3A	0.000 0	1.312 5	1.303 1	1.271 9	1.268 1	0.003 8	1.235 8	1.227 5	3B	1.244 8	1.253 3	1.271 9	1.276 9	0.005 0	1.312 5

Table 2 Unified screw threads, standard series – Limits of size (continued)

1	2	3	4	5	6	7	8	9	10	11	12	13	14	15	16	17	18	
Nominal size and threads per inch	Series designation	External threads									Internal threads							
		Class	Allowance	Major diameter		Effective diameter			Minor diameter		Class	Minor diameter		Effective diameter			Major diameter	
				Max.	Min.	Max.	Min.	Tol.	Max.	Min.		Min.	Max.	Min.	Max.	Tol.	Min.	
				in	in	in	in	in	in	in		in	in	in	in	in	in	in
1 5/16 — 18	UNEF	2A	0.001 5	1.311 0	1.302 3	1.274 9	1.270 0	0.004 9	1.242 8	1.233 9	2B	1.252 4	1.265 1	1.276 4	1.282 7	0.006 3	1.312 5	
		3A	0.000 0	1.312 5	1.303 8	1.276 4	1.272 8	0.003 6	1.244 3	1.236 7		3B	1.252 4	1.260 5	1.276 4	1.281 1	0.004 7	1.312 5
1 5/16 — 20	UN	2A	0.001 4	1.311 1	1.303 0	1.278 6	1.273 9	0.004 7	1.249 8	1.241 5	2B	1.258 4	1.269 9	1.280 0	1.286 1	0.006 1	1.312 5	
		3A	0.000 0	1.312 5	1.304 4	1.280 0	1.276 5	0.003 5	1.251 2	1.244 1		3B	1.258 4	1.266 2	1.280 0	1.284 5	0.004 5	1.312 5
1 5/16 — 28	UN	2A	0.001 2	1.311 3	1.304 8	1.288 1	1.284 0	0.004 1	1.267 5	1.260 8	2B	1.273 8	1.282 2	1.289 3	1.294 6	0.005 3	1.312 5	
		3A	0.000 0	1.312 5	1.306 0	1.289 3	1.286 2	0.003 1	1.268 7	1.263 0		3B	1.273 8	1.280 1	1.289 3	1.293 3	0.004 0	1.312 5
1 3/8 — 6	UNC	1A	0.002 4	1.372 6	1.345 3	1.264 3	1.252 3	0.012 0	1.168 1	1.144 1	1B	1.194 6	1.225 2	1.266 7	1.282 2	0.015 5	1.375 0	
		2A	0.002 4	1.372 6	1.354 4	1.264 3	1.256 3	0.008 0	1.168 1	1.148 1		2B	1.194 6	1.225 2	1.266 7	1.277 1	0.010 4	1.375 0
		3A	0.000 0	1.375 0	1.356 8	1.266 7	1.260 7	0.006 0	1.170 5	1.152 5			3B	1.194 6	1.214 6	1.266 7	1.274 5	0.007 8
1 3/8 — 8	UN	2A	0.002 2	1.372 8	1.357 8	1.291 6	1.284 4	0.007 2	1.219 4	1.203 2	2B	1.239 7	1.264 7	1.293 8	1.303 1	0.009 3	1.375 0	
		3A	0.000 0	1.375 0	1.360 0	1.293 8	1.288 4	0.005 4	1.221 6	1.207 2		3B	1.239 7	1.254 7	1.293 8	1.300 8	0.007 0	1.375 0
1 3/8 — 12	UNF	1A	0.001 9	1.373 1	1.355 9	1.319 0	1.309 6	0.009 4	1.270 9	1.255 5	1B	1.284 8	1.302 9	1.320 9	1.333 2	0.012 3	1.375 0	
		2A	0.001 9	1.373 1	1.361 7	1.319 0	1.312 7	0.006 3	1.270 9	1.258 6		2B	1.284 8	1.302 9	1.320 9	1.329 1	0.008 2	1.375 0
		3A	0.000 0	1.375 0	1.363 6	1.320 9	1.316 2	0.004 7	1.272 8	1.262 1			3B	1.284 8	1.294 8	1.320 9	1.327 0	0.006 1
1 3/8 — 16	UN	2A	0.001 5	1.373 5	1.364 1	1.332 9	1.327 8	0.005 1	1.296 8	1.287 2	2B	1.307 3	1.321 4	1.334 4	1.341 0	0.006 6	1.375 0	
		3A	0.000 0	1.375 0	1.365 6	1.334 4	1.330 6	0.003 8	1.298 3	1.290 0		3B	1.307 3	1.315 8	1.334 4	1.339 4	0.005 0	1.375 0
1 3/8 — 18	UNEF	2A	0.001 5	1.373 5	1.364 8	1.337 4	1.332 5	0.004 9	1.305 3	1.296 4	2B	1.314 9	1.327 6	1.338 9	1.345 2	0.006 3	1.375 0	
		3A	0.000 0	1.375 0	1.366 3	1.338 9	1.335 3	0.003 6	1.306 8	1.299 2		3B	1.314 9	1.323 0	1.338 9	1.343 6	0.004 7	1.375 0
1 3/8 — 20	UN	2A	0.001 4	1.373 6	1.365 5	1.341 1	1.336 4	0.004 7	1.312 3	1.304 0	2B	1.320 9	1.332 4	1.342 5	1.348 6	0.006 1	1.375 0	
		3A	0.000 0	1.375 0	1.366 9	1.342 5	1.339 0	0.003 5	1.313 7	1.306 6		3B	1.320 9	1.328 7	1.342 5	1.347 0	0.004 5	1.375 0
1 3/8 — 28	UN	2A	0.001 2	1.373 8	1.367 3	1.350 6	1.346 5	0.004 1	1.330 0	1.323 3	2B	1.336 3	1.344 7	1.351 8	1.357 1	0.005 3	1.375 0	
		3A	0.000 0	1.375 0	1.368 5	1.351 8	1.348 7	0.003 1	1.331 2	1.325 5		3B	1.336 3	1.342 6	1.351 8	1.355 8	0.004 0	1.375 0
1 7/16 — 6	UN	2A	0.002 4	1.435 1	1.416 9	1.326 8	1.318 8	0.008 0	1.230 6	1.210 6	2B	1.257 1	1.287 7	1.329 2	1.339 6	0.010 4	1.437 5	
		3A	0.000 0	1.437 5	1.419 3	1.329 2	1.323 2	0.006 0	1.233 0	1.215 0		3B	1.257 1	1.277 1	1.329 2	1.337 0	0.007 8	1.437 5
1 7/16 — 8	UN	2A	0.002 2	1.435 3	1.420 3	1.354 1	1.346 9	0.007 2	1.281 9	1.265 7	2B	1.302 2	1.327 2	1.356 3	1.365 7	0.009 4	1.437 5	
		3A	0.000 0	1.437 5	1.422 5	1.356 3	1.350 9	0.005 4	1.284 1	1.269 7		3B	1.302 2	1.317 2	1.356 3	1.363 4	0.007 1	1.437 5
1 7/16 — 12	UN	2A	0.001 8	1.435 7	1.424 3	1.381 6	1.375 7	0.005 9	1.333 5	1.321 6	2B	1.347 3	1.365 4	1.383 4	1.391 0	0.007 6	1.437 5	
		3A	0.000 0	1.437 5	1.426 1	1.383 4	1.379 0	0.004 4	1.335 3	1.324 9		3B	1.347 3	1.357 3	1.383 4	1.389 1	0.005 7	1.437 5

Table 2 Unified screw threads, standard series – Limits of size (continued)

1	2	3	4	5	6	7	8	9	10	11	12	13	14	15	16	17	18
Nominal size and threads per inch	Series designation	External threads									Internal threads						
		Class	Allowance in	Major diameter		Effective diameter			Minor diameter		Class	Minor diameter		Effective diameter			Major diameter
				Max.	Min.	Max.	Min.	Tol.	Max.	Min.		Min.	Max.	Min.	Max.	Tol.	Min.
				in	in	in	in	in	in	in		in	in	in	in	in	in
1 ⁷ / ₁₆ — 16	UN	2A	0.001 6	1.435 9	1.426 5	1.395 3	1.390 1	0.005 2	1.359 2	1.349 5	2B	1.369 8	1.383 9	1.396 9	1.403 7	0.006 8	1.437 5
		3A	0.000 0	1.437 5	1.428 1	1.396 9	1.393 0	0.003 9	1.360 8	1.352 4	3B	1.369 8	1.378 3	1.396 9	1.402 0	0.005 1	1.437 5
1 ⁷ / ₁₆ — 18	UNEF	2A	0.001 5	1.436 0	1.427 3	1.399 9	1.394 9	0.005 0	1.367 8	1.358 8	2B	1.377 4	1.390 1	1.401 4	1.407 9	0.006 5	1.437 5
		3A	0.000 0	1.437 5	1.428 8	1.401 4	1.397 7	0.003 7	1.369 3	1.361 6	3B	1.377 4	1.385 5	1.401 4	1.406 2	0.004 8	1.437 5
1 ⁷ / ₁₆ — 20	UN	2A	0.001 4	1.436 1	1.428 0	1.403 6	1.398 8	0.004 8	1.374 8	1.366 4	2B	1.383 4	1.394 9	1.405 0	1.411 2	0.006 2	1.437 5
		3A	0.000 0	1.437 5	1.429 4	1.405 0	1.401 4	0.003 6	1.376 2	1.369 0	3B	1.383 4	1.391 2	1.405 0	1.409 6	0.004 6	1.437 5
1 ⁷ / ₁₆ — 28	UN	2A	0.001 3	1.436 2	1.429 7	1.413 0	1.408 8	0.004 2	1.392 4	1.385 6	2B	1.398 8	1.407 2	1.414 3	1.419 8	0.005 5	1.437 5
		3A	0.000 0	1.437 5	1.431 0	1.414 3	1.411 2	0.003 1	1.393 7	1.388 0	3B	1.398 8	1.405 1	1.414 3	1.418 4	0.004 1	1.437 5
1 ¹ / ₂ — 6	UNC	1A	0.002 4	1.497 6	1.470 3	1.389 3	1.377 2	0.012 1	1.293 1	1.269 0	1B	1.319 6	1.350 2	1.391 7	1.407 5	0.015 8	1.500 0
		2A	0.002 4	1.497 6	1.479 4	1.389 3	1.381 2	0.008 1	1.293 1	1.273 0	2B	1.319 6	1.350 2	1.391 7	1.402 2	0.010 5	1.500 0
		3A	0.000 0	1.500 0	1.481 8	1.391 7	1.385 6	0.006 1	1.295 5	1.277 4	3B	1.319 6	1.339 6	1.391 7	1.399 6	0.007 9	1.500 0
1 ¹ / ₂ — 8	UN	2A	0.002 2	1.497 8	1.482 8	1.416 6	1.409 3	0.007 3	1.344 4	1.328 1	2B	1.364 7	1.389 7	1.418 8	1.428 3	0.009 5	1.500 0
		3A	0.000 0	1.500 0	1.485 0	1.418 8	1.413 3	0.005 5	1.346 6	1.332 1	3B	1.364 7	1.379 7	1.418 8	1.425 9	0.007 1	1.500 0
1 ¹ / ₂ — 12	UNF	1A	0.001 9	1.498 1	1.480 9	1.444 0	1.434 4	0.009 6	1.395 9	1.380 3	1B	1.409 8	1.427 9	1.445 9	1.458 4	0.012 5	1.500 0
		2A	0.001 9	1.498 1	1.486 7	1.444 0	1.437 6	0.006 4	1.395 9	1.383 5	2B	1.409 8	1.427 9	1.445 9	1.454 2	0.008 3	1.500 0
		3A	0.000 0	1.500 0	1.488 6	1.445 9	1.441 1	0.004 8	1.397 8	1.387 0	3B	1.409 8	1.419 8	1.445 9	1.452 2	0.006 3	1.500 0
1 ¹ / ₂ — 16	UN	2A	0.001 6	1.498 4	1.489 0	1.457 8	1.452 6	0.005 2	1.421 7	1.412 0	2B	1.432 3	1.446 4	1.459 4	1.466 2	0.006 8	1.500 0
		3A	0.000 0	1.500 0	1.490 6	1.459 4	1.455 5	0.003 9	1.423 3	1.414 9	3B	1.432 3	1.440 8	1.459 4	1.464 5	0.005 1	1.500 0
1 ¹ / ₂ — 18	UNEF	2A	0.001 5	1.498 5	1.489 8	1.462 4	1.457 4	0.005 0	1.430 3	1.421 3	2B	1.439 9	1.452 6	1.463 9	1.470 4	0.006 5	1.500 0
		3A	0.000 0	1.500 0	1.491 3	1.463 9	1.460 2	0.003 7	1.431 8	1.424 1	3B	1.439 9	1.448 0	1.463 9	1.468 7	0.004 8	1.500 0
1 ¹ / ₂ — 20	UN	2A	0.001 4	1.498 6	1.490 5	1.466 1	1.461 3	0.004 8	1.437 3	1.428 9	2B	1.445 9	1.457 4	1.467 5	1.473 7	0.006 2	1.500 0
		3A	0.000 0	1.500 0	1.491 9	1.467 5	1.463 9	0.003 6	1.438 7	1.431 5	3B	1.445 9	1.453 7	1.467 5	1.472 1	0.004 6	1.500 0
1 ¹ / ₂ — 28	UN	2A	0.001 3	1.498 7	1.492 2	1.475 5	1.471 3	0.004 2	1.454 9	1.448 1	2B	1.461 3	1.469 7	1.476 8	1.482 3	0.005 5	1.500 0
		3A	0.000 0	1.500 0	1.493 5	1.476 8	1.473 7	0.003 1	1.456 2	1.450 5	3B	1.461 3	1.467 6	1.476 8	1.480 9	0.004 1	1.500 0
1 ⁹ / ₁₆ — 6	UN	2A	0.002 4	1.560 1	1.541 9	1.451 8	1.443 6	0.008 2	1.355 6	1.355 4	2B	1.382 1	1.412 7	1.454 2	1.464 8	0.010 6	1.562 5
		3A	0.000 0	1.562 5	1.544 3	1.454 2	1.448 1	0.006 1	1.358 0	1.339 9	3B	1.382 1	1.402 1	1.454 2	1.462 2	0.008 0	1.562 5
1 ⁹ / ₁₆ — 8	UN	2A	0.002 2	1.560 3	1.545 3	1.479 1	1.471 7	0.007 4	1.406 9	1.390 5	2B	1.427 2	1.452 2	1.481 3	1.490 9	0.009 6	1.562 5
		3A	0.000 0	1.562 5	1.547 5	1.481 3	1.475 8	0.005 5	1.409 1	1.394 6	3B	1.427 2	1.442 2	1.481 3	1.488 5	0.007 2	1.562 5

Table 2 Unified screw threads, standard series – Limits of size (continued)

1	2	3	4	5	6	7	8	9	10	11	12	13	14	15	16	17	18
Nominal size and threads per inch	Series designation	External threads									Internal threads						
		Class	Allowance	Major diameter		Effective diameter			Minor diameter		Class	Minor diameter		Effective diameter			Major diameter
				Max.	Min.	Max.	Min.	Tol.	Max.	Min.		Min.	Max.	Min.	Max.	Tol.	
				in	in	in	in	in	in	in		in	in	in	in	in	
1 $\frac{9}{16}$ — 12	UN	2A	0.001 8	1.560 7	1.549 3	1.506 6	1.500 7	0.005 9	1.458 5	1.446 6	2B	1.472 3	1.490 4	1.508 4	1.516 0	0.007 6	1.562 5
		3A	0.000 0	1.562 5	1.551 1	1.508 4	1.504 0	0.004 4	1.460 3	1.449 9	3B	1.472 3	1.482 3	1.508 4	1.514 1	0.005 7	1.562 5
1 $\frac{9}{16}$ — 16	UN	2A	0.001 6	1.560 9	1.551 5	1.520 3	1.515 1	0.005 2	1.484 2	1.474 5	2B	1.494 8	1.508 9	1.521 9	1.528 7	0.006 8	1.562 5
		3A	0.000 0	1.562 5	1.553 1	1.521 9	1.518 0	0.003 9	1.485 8	1.477 4	3B	1.494 8	1.503 3	1.521 9	1.527 0	0.005 1	1.562 5
1 $\frac{9}{16}$ — 18	UNEF	2A	0.001 5	1.561 0	1.552 3	1.524 9	1.519 9	0.005 0	1.492 8	1.483 8	2B	1.502 4	1.515 1	1.526 4	1.532 9	0.006 5	1.562 5
		3A	0.000 0	1.562 5	1.553 8	1.526 4	1.522 7	0.003 7	1.494 3	1.486 6	3B	1.502 4	1.510 5	1.526 4	1.531 2	0.004 8	1.562 5
1 $\frac{9}{16}$ — 20	UN	2A	0.001 4	1.561 1	1.553 0	1.582 6	1.523 8	0.004 8	1.499 8	1.491 4	2B	1.508 4	1.519 9	1.530 0	1.536 2	0.006 2	1.562 5
		3A	0.000 0	1.562 5	1.554 4	1.530 0	1.526 4	0.003 6	1.501 2	1.494 0	3B	1.508 4	1.516 2	1.530 0	1.534 6	0.004 6	1.562 5
1 $\frac{5}{8}$ — 6	UN	2A	0.002 5	1.622 5	1.604 3	1.514 2	1.506 0	0.008 2	1.418 0	1.397 8	2B	1.444 6	1.475 2	1.516 7	1.527 4	0.010 7	1.625 0
		3A	0.000 0	1.625 0	1.606 8	1.516 7	1.510 5	0.006 2	1.420 5	1.402 3	3B	1.444 6	1.464 6	1.516 7	1.524 7	0.008 0	1.625 0
1 $\frac{5}{8}$ — 8	UN	2A	0.002 2	1.622 8	1.607 8	1.541 6	1.534 2	0.007 4	1.469 4	1.453 0	2B	1.489 7	1.514 7	1.543 8	1.553 5	0.009 7	1.625 0
		3A	0.000 0	1.625 0	1.610 0	1.543 8	1.538 2	0.005 6	1.471 6	1.457 0	3B	1.489 7	1.504 7	1.543 8	1.551 0	0.007 2	1.625 0
1 $\frac{5}{8}$ — 12	UN	2A	0.001 8	1.623 2	1.611 8	1.569 1	1.563 2	0.005 9	1.521 0	1.509 1	2B	1.534 8	1.552 9	1.570 9	1.578 5	0.007 6	1.625 0
		3A	0.000 0	1.625 0	1.613 6	1.570 9	1.566 5	0.004 4	1.522 8	1.512 4	3B	1.534 8	1.544 8	1.570 9	1.576 6	0.005 7	1.625 0
1 $\frac{5}{8}$ — 16	UN	2A	0.001 6	1.623 4	1.614 0	1.582 8	1.577 6	0.005 2	1.546 7	1.537 0	2B	1.557 3	1.571 4	1.584 4	1.591 2	0.006 8	1.625 0
		3A	0.000 0	1.625 0	1.615 6	1.584 4	1.580 5	0.003 9	1.548 3	1.539 9	3B	1.557 3	1.565 8	1.584 4	1.589 5	0.005 1	1.625 0
1 $\frac{5}{8}$ — 18	UNEF	2A	0.001 5	1.623 5	1.614 8	1.587 4	1.582 4	0.005 0	1.555 3	1.546 3	2B	1.564 9	1.577 6	1.588 9	1.595 4	0.006 5	1.625 0
		3A	0.000 0	1.625 0	1.616 3	1.588 9	1.585 2	0.003 7	1.556 8	1.549 1	3B	1.564 9	1.573 0	1.588 9	1.593 7	0.004 8	1.625 0
1 $\frac{5}{8}$ — 20	UN	2A	0.001 4	1.623 6	1.615 5	1.591 1	1.586 3	0.004 8	1.562 3	1.553 9	2B	1.570 9	1.582 4	1.592 5	1.598 7	0.006 2	1.625 0
		3A	0.000 0	1.625 0	1.616 9	1.592 5	1.588 9	0.003 6	1.563 7	1.556 5	3B	1.570 9	1.578 7	1.592 5	1.597 1	0.004 6	1.625 0
1 $\frac{11}{16}$ — 6	UN	2A	0.002 5	1.685 0	1.666 8	1.576 7	1.568 4	0.008 3	1.480 5	1.460 2	2B	1.507 1	1.537 7	1.579 2	1.590 0	0.010 8	1.687 5
		3A	0.000 0	1.687 5	1.669 3	1.579 2	1.573 0	0.006 2	1.483 0	1.464 8	3B	1.507 1	1.527 1	1.579 2	1.587 3	0.008 1	1.687 5
1 $\frac{11}{16}$ — 8	UN	2A	0.002 2	1.685 3	1.670 3	1.604 1	1.596 6	0.007 5	1.531 9	1.515 4	2B	1.552 2	1.577 2	1.606 3	1.616 0	0.009 7	1.687 5
		3A	0.000 0	1.687 5	1.672 5	1.606 3	1.600 7	0.005 6	1.534 1	1.519 5	3B	1.552 2	1.567 2	1.606 3	1.613 6	0.007 3	1.687 5
1 $\frac{11}{16}$ — 12	UN	2A	0.001 8	1.685 7	1.674 3	1.631 6	1.625 6	0.006 0	1.583 5	1.571 5	2B	1.597 3	1.615 4	1.633 4	1.641 2	0.007 8	1.687 5
		3A	0.000 0	1.687 5	1.676 1	1.633 4	1.628 9	0.004 5	1.585 3	1.574 8	3B	1.597 3	1.607 3	1.633 4	1.639 2	0.005 8	1.687 5

Table 2 Unified screw threads, standard series – Limits of size (continued)

1	2	3	4	5	6	7	8	9	10	11	12	13	14	15	16	17	18
Nominal size and threads per inch	Series designation	External threads									Internal threads						
		Class	Allowance in	Major diameter		Effective diameter			Minor diameter		Class	Minor diameter		Effective diameter			Major diameter
				Max.	Min.	Max.	Min.	Tol.	Max.	Min.		Min.	Max.	Min.	Max.	Tol.	Min.
				in	in	in	in	in	in	in		in	in	in	in	in	in
1 $\frac{11}{16}$ — 16	UN	2A	0.001 6	1.685 9	1.676 5	1.645 3	1.640 0	0.005 3	1.609 2	1.599 4	2B	1.619 8	1.633 9	1.646 9	1.653 8	0.006 9	1.687 5
		3A	0.000 0	1.687 5	1.678 1	1.646 9	1.642 9	0.004 0	1.610 8	1.602 3	3B	1.619 8	1.628 3	1.646 9	1.652 1	0.005 2	1.687 5
1 $\frac{11}{16}$ — 18	UNEF	2A	0.001 5	1.686 0	1.677 3	1.649 9	1.644 8	0.005 1	1.617 8	1.608 7	2B	1.627 4	1.640 1	1.651 4	1.658 0	0.006 6	1.687 5
		3A	0.000 0	1.687 5	1.678 8	1.651 4	1.647 6	0.003 8	1.619 3	1.611 5	3B	1.627 4	1.635 5	1.651 4	1.656 3	0.004 9	1.687 5
1 $\frac{11}{16}$ — 20	UN	2A	0.001 5	1.686 0	1.677 9	1.653 5	1.648 7	0.004 8	1.624 7	1.616 3	2B	1.633 4	1.644 9	1.655 0	1.661 3	0.006 3	1.687 5
		3A	0.000 0	1.687 5	1.679 4	1.655 0	1.651 4	0.003 6	1.626 2	1.619 0	3B	1.633 4	1.641 2	1.655 0	1.659 7	0.004 7	1.687 5
1 $\frac{3}{4}$ — 5	UNC	1A	0.002 7	1.747 3	1.716 5	1.617 4	1.604 0	0.013 4	1.501 9	1.474 1	1B	1.533 5	1.567 5	1.620 1	1.637 5	0.017 4	1.750 0
		2A	0.002 7	1.747 3	1.726 8	1.617 4	1.608 5	0.008 9	1.501 9	1.478 6	2B	1.533 5	1.567 5	1.620 1	1.631 7	0.011 6	1.750 0
		3A	0.000 0	1.750 0	1.729 5	1.620 1	1.613 4	0.006 7	1.504 6	1.483 5	3B	1.533 5	1.557 5	1.620 1	1.628 8	0.008 7	1.750 0
1 $\frac{3}{4}$ — 6	UN	2A	0.002 5	1.747 5	1.729 3	1.639 2	1.630 9	0.008 3	1.543 0	1.522 7	2B	1.569 6	1.600 2	1.641 7	1.652 5	0.010 8	1.750 0
		3A	0.000 0	1.750 0	1.731 8	1.641 7	1.635 4	0.006 3	1.545 5	1.527 2	3B	1.569 6	1.589 6	1.641 7	1.649 8	0.008 1	1.750 0
1 $\frac{3}{4}$ — 8	UN	2A	0.002 3	1.747 7	1.732 7	1.666 5	1.659 0	0.007 5	1.594 3	1.577 8	2B	1.614 7	1.639 7	1.668 8	1.678 6	0.009 8	1.750 0
		3A	0.000 0	1.750 0	1.735 0	1.668 8	1.663 2	0.005 6	1.596 6	1.582 0	3B	1.614 7	1.629 7	1.668 8	1.676 2	0.007 4	1.750 0
1 $\frac{3}{4}$ — 12	UN	2A	0.001 8	1.748 2	1.736 8	1.694 1	1.688 1	0.006 0	1.646 0	1.634 0	2B	1.659 8	1.677 9	1.695 9	1.703 7	0.007 8	1.750 0
		3A	0.000 0	1.750 0	1.738 6	1.695 9	1.691 4	0.004 5	1.647 8	1.637 3	3B	1.659 8	1.669 8	1.695 9	1.701 7	0.005 8	1.750 0
1 $\frac{3}{4}$ — 16	UN	2A	0.001 6	1.748 4	1.739 0	1.707 8	1.702 5	0.005 3	1.671 7	1.661 9	2B	1.682 3	1.696 4	1.709 4	1.716 3	0.006 9	1.750 0
		3A	0.000 0	1.750 0	1.740 6	1.709 4	1.705 4	0.004 0	1.673 3	1.664 8	3B	1.682 3	1.690 8	1.709 4	1.714 6	0.005 2	1.750 0
1 $\frac{3}{4}$ — 20	UN	2A	0.001 5	1.748 5	1.740 4	1.716 0	1.711 2	0.004 8	1.687 2	1.678 8	2B	1.695 9	1.707 4	1.717 5	1.723 8	0.006 3	1.750 0
		3A	0.000 0	1.750 0	1.741 9	1.717 5	1.713 9	0.003 6	1.688 7	1.681 5	3B	1.695 9	1.703 7	1.717 5	1.722 2	0.004 7	1.750 0
1 $\frac{13}{16}$ — 6	UN	2A	0.002 5	1.810 0	1.791 8	1.701 7	1.693 3	0.008 4	1.605 5	1.585 1	2B	1.632 1	1.662 7	1.704 2	1.715 1	0.010 9	1.812 5
		3A	0.000 0	1.812 5	1.794 3	1.704 2	1.697 9	0.006 3	1.608 0	1.589 7	3B	1.632 1	1.652 1	1.704 2	1.712 4	0.008 2	1.812 5
1 $\frac{13}{16}$ — 8	UN	2A	0.002 3	1.810 2	1.795 2	1.729 0	1.721 4	0.007 6	1.656 8	1.640 2	2B	1.677 2	1.702 2	1.731 3	1.741 2	0.009 9	1.812 5
		3A	0.000 0	1.812 5	1.797 5	1.731 3	1.725 6	0.005 7	1.659 1	1.644 4	3B	1.677 2	1.692 2	1.731 3	1.738 7	0.007 4	1.812 5
1 $\frac{13}{16}$ — 12	UN	2A	0.001 8	1.810 7	1.799 3	1.756 6	1.750 6	0.006 0	1.708 5	1.696 5	2B	1.722 3	1.740 4	1.758 4	1.766 2	0.007 8	1.812 5
		3A	0.000 0	1.812 5	1.801 1	1.758 4	1.753 9	0.004 5	1.710 3	1.699 8	3B	1.722 3	1.732 3	1.758 4	1.764 2	0.005 8	1.812 5
1 $\frac{13}{16}$ — 16	UN	2A	0.001 6	1.810 9	1.801 5	1.770 3	1.765 0	0.005 3	1.734 2	1.724 4	2B	1.744 8	1.758 9	1.771 9	1.778 8	0.006 9	1.812 5
		3A	0.000 0	1.812 5	1.803 1	1.771 9	1.767 9	0.004 0	1.735 8	1.727 3	3B	1.744 8	1.753 3	1.771 9	1.777 1	0.005 2	1.812 5

Table 2 Unified screw threads, standard series – Limits of size (continued)

1	2	3	4	5	6	7	8	9	10	11	12	13	14	15	16	17	18
Nominal size and threads per inch	Series designation	External threads									Internal threads						
		Class	Allowance	Major diameter		Effective diameter			Minor diameter		Class	Minor diameter		Effective diameter			Major diameter
				Max.	Min.	Max.	Min.	Tol.	Max.	Min.		Min.	Max.	Min.	Max.	Tol.	Min.
				in	in	in	in	in	in	in		in	in	in	in	in	in
1 $\frac{13}{16}$ — 20	UN	2A	0.001 5	1.811 0	1.802 9	1.778 5	1.773 7	0.004 8	1.749 7	1.741 3	2B	1.758 4	1.769 9	1.780 0	1.786 3	0.006 3	1.812 5
		3A	0.000 0	1.812 5	1.804 4	1.780 0	1.776 4	0.003 6	1.751 2	1.744 0	3B	1.758 4	1.766 2	1.780 0	1.784 7	0.004 7	1.812 5
1 $\frac{7}{8}$ — 6	UN	2A	0.002 5	1.872 5	1.854 3	1.764 2	1.755 8	0.008 4	1.668 0	1.647 6	2B	1.694 6	1.725 2	1.766 7	1.777 7	0.011 0	1.875 0
		3A	0.000 0	1.875 0	1.856 8	1.766 7	1.760 4	0.006 3	1.670 5	1.652 2	3B	1.694 6	1.714 6	1.766 7	1.774 9	0.008 2	1.875 0
1 $\frac{7}{8}$ — 8	UN	2A	0.002 3	1.872 7	1.857 7	1.791 5	1.783 8	0.007 7	1.719 3	1.702 6	2B	1.739 7	1.764 7	1.793 8	1.803 8	0.010 0	1.875 0
		3A	0.000 0	1.875 0	1.860 0	1.793 8	1.788 1	0.005 7	1.721 6	1.706 9	3B	1.739 7	1.754 7	1.793 8	1.801 3	0.007 5	1.875 0
1 $\frac{7}{8}$ — 12	UN	2A	0.001 8	1.873 2	1.861 8	1.819 1	1.813 1	0.006 0	1.771 0	1.759 0	2B	1.784 8	1.802 9	1.820 9	1.828 7	0.007 8	1.875 0
		3A	0.000 0	1.875 0	1.863 6	1.820 9	1.816 4	0.004 5	1.772 8	1.762 3	3B	1.784 8	1.794 8	1.820 9	1.826 7	0.005 8	1.875 0
1 $\frac{7}{8}$ — 16	UN	2A	0.001 6	1.873 4	1.864 0	1.832 8	1.827 5	0.005 3	1.796 7	1.786 9	2B	1.807 3	1.821 4	1.834 4	1.841 3	0.006 9	1.875 0
		3A	0.000 0	1.875 0	1.865 6	1.834 4	1.830 4	0.004 0	1.798 3	1.789 8	3B	1.807 3	1.815 8	1.834 4	1.839 6	0.005 2	1.875 0
1 $\frac{7}{8}$ — 20	UN	2A	0.001 5	1.873 5	1.865 4	1.841 0	1.836 2	0.004 8	1.812 2	1.803 8	2B	1.820 9	1.832 4	1.842 5	1.848 8	0.006 3	1.875 0
		3A	0.000 0	1.875 0	1.866 9	1.842 5	1.838 9	0.003 6	1.813 7	1.806 5	3B	1.820 9	1.828 7	1.842 5	1.847 2	0.004 7	1.875 0
1 $\frac{15}{16}$ — 6	UN	2A	0.002 6	1.934 9	1.916 7	1.826 6	1.818 1	0.008 5	1.730 4	1.709 9	2B	1.757 1	1.787 7	1.829 2	1.840 3	0.011 1	1.937 5
		3A	0.000 0	1.937 5	1.919 3	1.829 2	1.822 8	0.006 4	1.733 0	1.714 6	3B	1.757 1	1.777 1	1.829 2	1.837 5	0.008 3	1.937 5
1 $\frac{15}{16}$ — 8	UN	2A	0.002 3	1.935 2	1.920 2	1.854 0	1.846 3	0.007 7	1.781 8	1.765 1	2B	1.802 2	1.827 2	1.856 3	1.866 3	0.010 0	1.937 5
		3A	0.000 0	1.937 5	1.922 5	1.856 3	1.850 5	0.005 8	1.784 1	1.769 3	3B	1.802 2	1.817 2	1.856 3	1.863 8	0.007 5	1.937 5
1 $\frac{15}{16}$ — 12	UN	2A	0.001 8	1.935 7	1.924 3	1.881 6	1.875 5	0.006 1	1.833 5	1.821 4	2B	1.847 3	1.865 4	1.883 4	1.891 3	0.007 9	1.937 5
		3A	0.000 0	1.937 5	1.926 1	1.883 4	1.878 9	0.004 5	1.835 3	1.824 8	3B	1.847 3	1.857 3	1.883 4	1.889 3	0.005 9	1.937 5
1 $\frac{15}{16}$ — 16	UN	2A	0.001 6	1.935 9	1.926 5	1.895 3	1.889 9	0.005 4	1.859 2	1.849 3	2B	1.869 8	1.883 9	1.896 9	1.903 9	0.007 0	1.937 5
		3A	0.000 0	1.937 5	1.928 1	1.896 9	1.892 9	0.004 0	1.860 8	1.852 3	3B	1.869 8	1.878 3	1.896 9	1.902 1	0.005 2	1.937 5
1 $\frac{15}{16}$ — 20	UN	2A	0.001 5	1.936 0	1.927 9	1.903 5	1.898 6	0.004 9	1.874 7	1.866 2	2B	1.883 4	1.894 9	1.905 0	1.911 4	0.006 4	1.937 5
		3A	0.000 0	1.937 5	1.929 4	1.905 0	1.901 3	0.003 7	1.876 2	1.868 9	3B	1.883 4	1.891 2	1.905 0	1.909 8	0.004 8	1.937 5
2 — 4 $\frac{1}{2}$	UNC	1A	0.002 9	1.997 1	1.964 1	1.852 8	1.838 5	0.014 3	1.724 5	1.694 2	1B	1.759 4	1.795 2	1.855 7	1.874 3	0.018 6	2.000 0
		2A	0.002 9	1.997 1	1.975 1	1.852 8	1.843 3	0.009 5	1.724 5	1.699 0	2B	1.759 4	1.795 2	1.855 7	1.868 1	0.012 4	2.000 0
		3A	0.000 0	2.000 0	1.978 0	1.855 7	1.848 6	0.007 1	1.727 4	1.704 3	3B	1.759 4	1.786 1	1.855 7	1.865 0	0.009 3	2.000 0
2 — 6	UN	2A	0.002 6	1.997 4	1.979 2	1.889 1	1.880 5	0.008 6	1.792 9	1.772 3	2B	1.819 6	1.850 2	1.891 7	1.902 8	0.011 1	2.000 0
		3A	0.000 0	2.000 0	1.981 8	1.891 7	1.885 3	0.006 4	1.795 5	1.777 1	3B	1.819 6	1.839 6	1.891 7	1.900 0	0.008 3	2.000 0

Table 2 Unified screw threads, standard series – Limits of size (continued)

1	2	3	4	5	6	7	8	9	10	11	12	13	14	15	16	17	18
Nominal size and threads per inch	Series designation	External threads									Internal threads						
		Class	Allowance in	Major diameter		Effective diameter			Minor diameter		Class	Minor diameter		Effective diameter			Major diameter
				Max.	Min.	Max.	Min.	Tol.	Max.	Min.		Min.	Max.	Min.	Max.	Tol.	Min.
				in	in	in	in	in	in	in		in	in	in	in	in	in
2 — 8	UN	2A	0.002 3	1.997 7	1.982 7	1.916 5	1.908 7	0.007 8	1.844 3	1.827 5	2B	1.864 7	1.889 7	1.918 8	1.928 9	0.010 1	2.000 0
		3A	0.000 0	2.000 0	1.985 0	1.918 8	1.913 0	0.005 8	1.846 6	1.831 8	3B	1.864 7	1.879 7	1.918 8	1.926 4	0.007 6	2.000 0
2 — 12	UN	2A	0.001 8	1.998 2	1.986 8	1.944 1	1.938 0	0.006 1	1.896 0	1.883 9	2B	1.909 8	1.927 9	1.945 9	1.953 8	0.007 9	2.000 0
		3A	0.000 0	2.000 0	1.988 6	1.945 9	1.941 4	0.004 5	1.897 8	1.887 3	3B	1.909 8	1.919 8	1.945 9	1.951 8	0.005 9	2.000 0
2 — 16	UN	2A	0.001 6	1.998 4	1.989 0	1.957 8	1.952 4	0.005 4	1.921 7	1.911 8	2B	1.932 3	1.946 4	1.959 4	1.966 4	0.007 0	2.000 0
		3A	0.000 0	2.000 0	1.990 6	1.959 4	1.955 4	0.004 0	1.923 3	1.914 8	3B	1.932 3	1.940 8	1.959 4	1.964 6	0.005 2	2.000 0
2 — 20	UN	2A	0.001 5	1.998 5	1.990 4	1.966 0	1.961 1	0.004 9	1.937 2	1.928 7	2B	1.945 9	1.957 4	1.967 5	1.973 9	0.006 4	2.000 0
		3A	0.000 0	2.000 0	1.991 9	1.967 5	1.963 8	0.003 7	1.938 7	1.931 4	3B	1.945 9	1.953 7	1.967 5	1.972 3	0.004 8	2.000 0
2 $\frac{1}{8}$ — 6	UN	2A	0.002 6	2.122 4	2.104 2	2.014 1	2.005 4	0.008 7	1.917 9	1.897 2	2B	1.944 6	1.975 2	2.016 7	2.028 0	0.011 3	2.125 0
		3A	0.000 0	2.125 0	2.106 8	2.016 7	2.010 2	0.006 5	1.920 5	1.902 0	3B	1.944 6	1.964 6	2.016 7	2.025 1	0.008 4	2.125 0
2 $\frac{1}{8}$ — 8	UN	2A	0.002 4	2.122 6	2.107 6	2.041 4	2.033 5	0.007 9	1.969 2	1.952 3	2B	1.989 7	2.014 7	2.043 8	2.054 0	0.010 2	2.125 0
		3A	0.000 0	2.125 0	2.110 0	2.043 8	2.037 9	0.005 9	1.971 6	1.956 7	3B	1.989 7	2.004 7	2.043 8	2.051 5	0.007 7	2.125 0
2 $\frac{1}{8}$ — 12	UN	2A	0.001 8	2.123 2	2.111 8	2.069 1	2.063 0	0.006 1	2.021 0	2.008 9	2B	2.034 8	2.052 9	2.070 9	2.078 8	0.007 9	2.125 0
		3A	0.000 0	2.125 0	2.113 6	2.070 9	2.066 4	0.004 5	2.022 8	2.012 3	3B	2.034 8	2.044 8	2.070 9	2.076 8	0.005 9	2.125 0
2 $\frac{1}{8}$ — 16	UN	2A	0.001 6	2.123 4	2.114 0	2.082 8	2.077 4	0.005 4	2.046 7	2.036 8	2B	2.057 3	2.071 4	2.084 4	2.091 4	0.007 0	2.125 0
		3A	0.000 0	2.125 0	2.115 6	2.084 4	2.080 3	0.004 1	2.048 3	2.039 7	3B	2.057 3	2.065 8	2.084 4	2.089 6	0.005 2	2.125 0
2 $\frac{1}{8}$ — 20	UN	2A	0.001 5	2.123 5	2.115 4	2.091 0	2.086 1	0.004 9	2.062 2	2.053 7	2B	2.070 9	2.082 4	2.092 5	2.098 9	0.006 4	2.125 0
		3A	0.000 0	2.125 0	2.116 9	2.092 5	2.088 8	0.003 7	2.063 7	2.056 4	3B	2.070 9	2.078 7	2.092 5	2.097 3	0.004 8	2.125 0
2 $\frac{1}{4}$ — 4 $\frac{1}{2}$	UNC	1A	0.002 9	2.247 1	2.214 1	2.102 8	2.088 2	0.014 6	1.974 5	1.943 9	1B	2.009 4	2.045 2	2.105 7	2.124 7	0.019 0	2.250 0
		2A	0.002 9	2.247 1	2.225 1	2.102 8	2.093 1	0.009 7	1.974 5	1.948 8	2B	2.009 4	2.045 2	2.105 7	2.118 3	0.012 6	2.250 0
		3A	0.000 0	2.250 0	2.228 0	2.105 7	2.098 4	0.007 3	1.977 4	1.954 1	3B	2.009 4	2.036 1	2.105 7	2.115 2	0.009 5	2.250 0
2 $\frac{1}{4}$ — 6	UN	2A	0.002 6	2.247 4	2.229 2	2.139 1	2.130 3	0.008 8	2.042 9	2.022 1	2B	2.069 6	2.100 2	2.141 7	2.153 1	0.011 4	2.250 0
		3A	0.000 0	2.250 0	2.231 8	2.141 7	2.135 1	0.006 6	2.045 5	2.026 9	3B	2.069 6	2.089 6	2.141 7	2.150 2	0.008 5	2.250 0
2 $\frac{1}{4}$ — 8	UN	2A	0.002 4	2.247 6	2.232 6	2.166 4	2.158 4	0.008 0	2.094 2	2.077 2	2B	2.114 7	2.139 7	2.168 8	2.179 2	0.010 4	2.250 0
		3A	0.000 0	2.250 0	2.235 0	2.168 8	2.162 8	0.006 0	2.096 6	2.081 6	3B	2.114 7	2.129 7	2.168 8	2.176 6	0.007 8	2.250 0
2 $\frac{1}{4}$ — 12	UN	2A	0.001 8	2.248 2	2.236 8	2.194 1	2.188 0	0.006 1	2.146 0	2.133 9	2B	2.159 8	2.177 9	2.195 9	2.203 8	0.007 9	2.250 0
		3A	0.000 0	2.250 0	2.238 6	2.195 9	2.191 4	0.004 5	2.147 8	2.137 3	3B	2.159 8	2.169 8	2.195 9	2.201 8	0.005 9	2.250 0

Table 2 Unified screw threads, standard series – Limits of size (continued)

1	2	3	4	5	6	7	8	9	10	11	12	13	14	15	16	17	18
Nominal size and threads per inch	Series designation	External threads									Internal threads						
		Class	Allowance	Major diameter		Effective diameter			Minor diameter		Class	Minor diameter		Effective diameter			Major diameter
				Max.	Min.	Max.	Min.	Tol.	Max.	Min.		Min.	Max.	Min.	Max.	Tol.	Min.
				in	in	in	in	in	in	in		in	in	in	in	in	in
2¼ — 16	UN	2A	0.001 6	2.248 4	2.239 0	2.207 8	2.202 4	0.005 4	2.171 7	2.161 8	2B	2.182 3	2.196 4	2.209 4	2.216 4	0.007 0	2.250 0
		3A	0.000 0	2.250 0	2.240 6	2.209 4	2.205 3	0.004 1	2.173 3	2.164 7	3B	2.182 3	2.190 8	2.209 4	2.214 6	0.005 2	2.250 0
2¼ — 20	UN	2A	0.001 5	2.248 5	2.240 4	2.216 0	2.211 1	0.004 9	2.187 2	2.178 7	2B	2.195 9	2.207 4	2.217 5	2.223 9	0.006 4	2.250 0
		3A	0.000 0	2.250 0	2.241 9	2.217 5	2.213 7	0.003 8	2.188 7	2.181 3	3B	2.195 9	2.203 7	2.217 5	2.222 3	0.004 8	2.250 0
2⅜ — 6	UN	2A	0.002 7	2.372 3	2.354 1	2.264 0	2.255 1	0.008 9	2.167 8	2.146 9	2B	2.194 6	2.225 2	2.266 7	2.278 2	0.011 5	2.375 0
		3A	0.000 0	2.375 0	2.356 8	2.266 7	2.260 1	0.006 6	2.170 5	2.151 9	3B	2.194 6	2.214 6	2.266 7	2.275 3	0.008 6	2.375 0
2⅜ — 8	UN	2A	0.002 4	2.372 6	2.357 6	2.291 4	2.283 3	0.008 1	2.219 2	2.202 1	2B	2.239 7	2.264 7	2.293 8	2.304 3	0.010 5	2.375 0
		3A	0.000 0	2.375 0	2.360 0	2.293 8	2.287 8	0.006 0	2.221 6	2.206 6	3B	2.239 7	2.254 7	2.293 8	2.301 7	0.007 9	2.375 0
2⅜ — 12	UN	2A	0.001 9	2.373 1	2.361 7	2.319 0	2.312 8	0.006 2	2.270 9	2.258 7	2B	2.284 8	2.302 9	2.320 9	2.329 0	0.008 1	2.375 0
		3A	0.000 0	2.375 0	2.363 6	2.320 9	2.316 3	0.004 6	2.272 8	2.262 2	3B	2.284 8	2.294 8	2.320 9	2.326 9	0.006 0	2.375 0
2⅜ — 16	UN	2A	0.001 7	2.373 3	2.363 9	2.332 7	2.327 2	0.005 5	2.296 6	2.286 6	2B	2.307 3	2.321 4	2.334 4	2.341 6	0.007 2	2.375 0
		3A	0.000 0	2.375 0	2.365 6	2.334 4	2.330 3	0.004 1	2.298 3	2.289 7	3B	2.307 3	2.315 8	2.334 4	2.339 8	0.005 4	2.375 0
2⅜ — 20	UN	2A	0.001 5	2.373 5	2.365 4	2.341 0	2.335 9	0.005 1	2.312 2	2.303 5	2B	2.320 9	2.332 4	2.342 5	2.349 1	0.006 6	2.375 0
		3A	0.000 0	2.375 0	2.366 9	2.342 5	2.338 7	0.003 8	2.313 7	2.306 3	3B	2.320 9	2.328 7	2.342 5	2.347 5	0.005 0	2.375 0
2½ — 4	UNC	1A	0.003 1	2.496 9	2.461 2	2.334 5	2.319 0	0.015 5	2.190 2	2.156 7	1B	2.229 4	2.266 9	2.337 6	2.357 8	0.020 2	2.500 0
		2A	0.003 1	2.496 9	2.473 1	2.334 5	2.324 1	0.010 4	2.190 2	2.161 8	2B	2.229 4	2.266 9	2.337 6	2.351 1	0.013 5	2.500 0
		3A	0.000 0	2.500 0	2.476 2	2.337 6	2.329 8	0.007 8	2.193 3	2.167 5	3B	2.229 4	2.259 4	2.337 6	2.347 7	0.010 1	2.500 0
2½ — 6	UN	2A	0.002 7	2.497 3	2.479 1	2.389 0	2.380 0	0.009 0	2.292 8	2.271 8	2B	2.319 6	2.350 2	2.391 7	2.403 3	0.011 6	2.500 0
		3A	0.000 0	2.500 0	2.481 8	2.391 7	2.385 0	0.006 7	2.295 5	2.276 8	3B	2.319 6	2.339 6	2.391 7	2.400 4	0.008 7	2.500 0
2½ — 8	UN	2A	0.002 4	2.497 6	2.482 6	2.416 4	2.408 2	0.008 2	2.344 2	2.327 0	2B	2.364 7	2.389 7	2.418 8	2.429 4	0.010 6	2.500 0
		3A	0.000 0	2.500 0	2.485 0	2.418 8	2.412 7	0.006 1	2.346 6	2.331 5	3B	2.364 7	2.379 7	2.418 8	2.426 8	0.008 0	2.500 0
2½ — 12	UN	2A	0.001 9	2.498 1	2.486 7	2.444 0	2.437 8	0.006 2	2.395 9	2.383 7	2B	2.409 8	2.427 9	2.445 9	2.454 0	0.008 1	2.500 0
		3A	0.000 0	2.500 0	2.488 6	2.445 9	2.441 3	0.004 6	2.397 8	2.387 2	3B	2.409 8	2.419 8	2.445 9	2.451 9	0.006 0	2.500 0
2½ — 16	UN	2A	0.001 7	2.498 3	2.488 9	2.457 7	2.452 2	0.005 5	2.421 6	2.411 6	2B	2.432 3	2.446 4	2.459 4	2.466 6	0.007 2	2.500 0
		3A	0.000 0	2.500 0	2.490 6	2.459 4	2.455 3	0.004 1	2.423 3	2.414 7	3B	2.432 3	2.440 8	2.459 4	2.464 8	0.005 4	2.500 0
2½ — 20	UN	2A	0.001 5	2.498 5	2.490 4	2.466 0	2.460 9	0.005 1	2.437 2	2.428 5	2B	2.445 9	2.457 4	2.467 5	2.474 1	0.006 6	2.500 0
		3A	0.000 0	2.500 0	2.491 9	2.467 5	2.463 7	0.003 8	2.438 7	2.431 3	3B	2.445 9	2.453 7	2.467 5	2.472 5	0.005 0	2.500 0

Table 2 Unified screw threads, standard series – Limits of size (continued)

1	2	3	4	5	6	7	8	9	10	11	12	13	14	15	16	17	18
Nominal size and threads per inch	Series designation	External threads									Internal threads						
		Class	Allowance	Major diameter		Effective diameter			Minor diameter		Class	Minor diameter		Effective diameter			Major diameter
				Max.	Min.	Max.	Min.	Tol.	Max.	Min.		Min.	Max.	Min.	Max.	Tol.	Min.
				in	in	in	in	in	in	in		in	in	in	in	in	in
2 $\frac{5}{8}$ — 4	UN	2A	0.003 1	2.621 9	2.598 1	2.459 5	2.449 0	0.010 5	2.315 2	2.286 7	2B	2.354 4	2.391 9	2.462 6	2.476 2	0.013 6	2.625 0
		3A	0.000 0	2.625 0	2.601 2	2.462 6	2.454 8	0.007 8	2.318 3	2.292 5	3B	2.354 4	2.384 4	2.462 6	2.472 8	0.010 2	2.625 0
2 $\frac{5}{8}$ — 6	UN	2A	0.002 7	2.622 3	2.604 1	2.514 0	2.505 0	0.009 0	2.417 8	2.396 8	2B	2.444 6	2.475 2	2.516 7	2.528 5	0.011 8	2.625 0
		3A	0.000 0	2.625 0	2.606 8	2.516 7	2.509 9	0.006 8	2.420 5	2.401 7	3B	2.444 6	2.464 6	2.516 7	2.525 5	0.008 8	2.625 0
2 $\frac{5}{8}$ — 8	UN	2A	0.002 5	2.622 5	2.607 5	2.541 3	2.533 1	0.008 2	2.469 1	2.451 9	2B	2.489 7	2.514 7	2.543 8	2.554 5	0.010 7	2.625 0
		3A	0.000 0	2.625 0	2.610 0	2.543 8	2.537 6	0.006 2	2.471 6	2.456 4	3B	2.489 7	2.504 7	2.543 8	2.551 8	0.008 0	2.625 0
2 $\frac{5}{8}$ — 12	UN	2A	0.001 9	2.623 1	2.611 7	2.569 0	2.562 8	0.006 2	2.520 9	2.508 7	2B	2.534 8	2.552 9	2.570 9	2.579 0	0.008 1	2.625 0
		3A	0.000 0	2.625 0	2.613 6	2.570 9	2.566 3	0.004 6	2.522 8	2.512 2	3B	2.534 8	2.544 8	2.570 9	2.576 9	0.006 0	2.625 0
2 $\frac{5}{8}$ — 16	UN	2A	0.001 7	2.623 3	2.613 9	2.582 7	2.577 2	0.005 5	2.546 6	2.536 6	2B	2.557 3	2.571 4	2.584 4	2.591 6	0.007 2	2.625 0
		3A	0.000 0	2.625 0	2.615 6	2.584 4	2.580 3	0.004 1	2.548 3	2.539 7	3B	2.557 3	2.565 8	2.584 4	2.589 8	0.005 4	2.625 0
2 $\frac{5}{8}$ — 20	UN	2A	0.001 5	2.623 5	2.615 4	2.591 0	2.585 9	0.005 1	2.562 2	2.553 5	2B	2.570 9	2.582 4	2.592 5	2.599 1	0.006 6	2.625 0
		3A	0.000 0	2.625 0	2.616 9	2.592 5	2.588 7	0.003 8	2.563 7	2.556 3	3B	2.570 9	2.578 7	2.592 5	2.597 5	0.005 0	2.625 0
2 $\frac{3}{4}$ — 4	UNC	1A	0.003 2	2.746 8	2.711 1	2.584 4	2.568 6	0.015 8	2.440 1	2.406 3	1B	2.479 4	2.516 9	2.587 6	2.608 2	0.020 6	2.750 0
		2A	0.003 2	2.746 8	2.723 0	2.584 4	2.573 9	0.010 5	2.440 1	2.411 6	2B	2.479 4	2.516 9	2.587 6	2.601 3	0.013 7	2.750 0
		3A	0.000 0	2.750 0	2.726 2	2.587 6	2.579 7	0.007 9	2.443 3	2.417 4	3B	2.479 4	2.509 4	2.587 6	2.597 9	0.010 3	2.750 0
2 $\frac{3}{4}$ — 6	UN	2A	0.002 7	2.747 3	2.729 1	2.639 0	2.629 9	0.009 1	2.542 8	2.521 7	2B	2.569 6	2.600 2	2.641 7	2.653 6	0.011 9	2.750 0
		3A	0.000 0	2.750 0	2.731 8	2.641 7	2.634 9	0.006 8	2.545 5	2.526 7	3B	2.569 6	2.589 6	2.641 7	2.650 6	0.008 9	2.750 0
2 $\frac{3}{4}$ — 8	UN	2A	0.002 5	2.747 5	2.732 5	2.666 3	2.658 0	0.008 3	2.594 1	2.576 8	2B	2.614 7	2.639 7	2.668 8	2.679 6	0.010 8	2.750 0
		3A	0.000 0	2.750 0	2.735 0	2.668 8	2.662 5	0.006 3	2.596 6	2.581 3	3B	2.614 7	2.629 7	2.668 8	2.676 9	0.008 1	2.750 0
2 $\frac{3}{4}$ — 12	UN	2A	0.001 9	2.748 1	2.736 7	2.694 0	2.687 8	0.006 2	2.645 9	2.633 7	2B	2.659 8	2.677 9	2.695 9	2.704 0	0.008 1	2.750 0
		3A	0.000 0	2.750 0	2.738 6	2.695 9	2.691 3	0.004 6	2.647 8	2.637 2	3B	2.659 8	2.669 8	2.695 9	2.701 9	0.006 0	2.750 0
2 $\frac{3}{4}$ — 16	UN	2A	0.001 7	2.748 3	2.738 9	2.707 7	2.702 2	0.005 5	2.671 6	2.661 6	2B	2.682 3	2.696 4	2.709 4	2.716 6	0.007 2	2.750 0
		3A	0.000 0	2.750 0	2.740 6	2.709 4	2.705 3	0.004 1	2.673 3	2.664 7	3B	2.682 3	2.690 8	2.709 4	2.714 8	0.005 4	2.750 0
2 $\frac{3}{4}$ — 20	UN	2A	0.001 5	2.748 5	2.740 4	2.716 0	2.710 9	0.005 1	2.687 2	2.678 5	2B	2.695 9	2.707 4	2.717 5	2.724 1	0.006 6	2.750 0
		3A	0.000 0	2.750 0	2.741 9	2.717 5	2.713 7	0.003 8	2.688 7	2.681 3	3B	2.695 9	2.703 7	2.717 5	2.722 5	0.005 0	2.750 0
2 $\frac{7}{8}$ — 4	UN	2A	0.003 2	2.871 8	2.848 0	2.709 4	2.698 8	0.010 6	2.565 1	2.536 5	2B	2.604 4	2.641 9	2.712 6	2.726 4	0.013 8	2.875 0
		3A	0.000 0	2.875 0	2.851 2	2.712 6	2.704 6	0.008 0	2.568 3	2.542 3	3B	2.604 4	2.634 4	2.712 6	2.723 0	0.010 4	2.875 0

Table 2 Unified screw threads, standard series – Limits of size (continued)

1	2	3	4	5	6	7	8	9	10	11	12	13	14	15	16	17	18
Nominal size and threads per inch	Series designation	External threads									Internal threads						
		Class	Allowance	Major diameter		Effective diameter			Minor diameter		Class	Minor diameter		Effective diameter			Major diameter
				Max.	Min.	Max.	Min.	Tol.	Max.	Min.		Min.	Max.	Min.	Max.	Tol.	Min.
				in	in	in	in	in	in	in		in	in	in	in	in	in
2 ⁷ / ₈ – 6	UN	2A	0.002 8	2.872 2	2.854 0	2.763 9	2.754 7	0.009 2	2.667 7	2.646 5	2B	2.694 6	2.725 2	2.766 7	2.778 7	0.012 0	2.875 0
		3A	0.000 0	2.875 0	2.856 8	2.766 7	2.759 8	0.006 9	2.670 5	2.651 6	3B	2.694 6	2.714 6	2.766 7	2.775 7	0.009 0	2.875 0
2 ⁷ / ₈ – 8	UN	2A	0.002 5	2.872 5	2.857 5	2.791 3	2.782 9	0.008 4	2.719 1	2.701 7	2B	2.739 7	2.764 7	2.793 8	2.804 8	0.011 0	2.875 0
		3A	0.000 0	2.875 0	2.860 0	2.793 8	2.787 5	0.006 3	2.721 6	2.706 3	3B	2.739 7	2.754 7	2.793 8	2.802 0	0.008 2	2.875 0
2 ⁷ / ₈ – 12	UN	2A	0.001 9	2.873 1	2.861 7	2.819 0	2.812 7	0.006 3	2.770 9	2.758 6	2B	2.784 8	2.802 9	2.820 9	2.829 1	0.008 2	2.875 0
		3A	0.000 0	2.875 0	2.863 6	2.820 9	2.816 2	0.004 7	2.772 8	2.762 1	3B	2.784 8	2.794 8	2.820 9	2.827 1	0.006 2	2.875 0
2 ⁷ / ₈ – 16	UN	2A	0.001 7	2.873 3	2.863 9	2.832 7	2.827 1	0.005 6	2.796 6	2.786 5	2B	2.807 3	2.821 4	2.834 4	2.841 7	0.007 3	2.875 0
		3A	0.000 0	2.875 0	2.865 6	2.834 4	2.830 2	0.004 2	2.798 3	2.789 6	3B	2.807 3	2.815 8	2.834 4	2.839 9	0.005 5	2.875 0
2 ⁷ / ₈ – 20	UN	2A	0.001 6	2.873 4	2.865 3	2.840 9	2.835 7	0.005 2	2.812 1	2.803 3	2B	2.820 9	2.832 4	2.842 5	2.849 3	0.006 8	2.875 0
		3A	0.000 0	2.875 0	2.866 9	2.842 5	2.838 6	0.003 9	2.813 7	2.806 2	3B	2.820 9	2.828 7	2.842 5	2.847 6	0.005 1	2.875 0
3 – 4	UNC	1A	0.003 2	2.996 8	2.961 1	2.834 4	2.818 3	0.016 1	2.690 1	2.656 0	1B	2.729 4	2.766 9	2.837 6	2.858 5	0.020 9	3.000 0
		2A	0.003 2	2.996 8	2.973 0	2.834 4	2.823 7	0.010 7	2.690 1	2.661 4	2B	2.729 4	2.766 9	2.837 6	2.851 5	0.013 9	3.000 0
		3A	0.000 0	3.000 0	2.976 2	2.837 6	2.829 6	0.008 0	2.693 3	2.667 3	3B	2.729 4	2.759 4	2.837 6	2.848 0	0.010 4	3.000 0
3 – 6	UN	2A	0.002 8	2.997 2	2.979 0	2.888 9	2.879 6	0.009 3	2.792 7	2.771 4	2B	2.819 6	2.850 2	2.891 7	2.903 8	0.012 1	3.000 0
		3A	0.000 0	3.000 0	2.981 8	2.891 7	2.884 7	0.007 0	2.795 5	2.776 5	3B	2.819 6	2.839 6	2.891 7	2.900 8	0.009 1	3.000 0
3 – 8	UN	2A	0.002 6	2.997 4	2.982 4	2.916 2	2.907 7	0.008 5	2.844 0	2.826 5	2B	2.864 7	2.889 7	2.918 8	2.929 9	0.011 1	3.000 0
		3A	0.000 0	3.000 0	2.985 0	2.918 8	2.912 4	0.006 4	2.846 6	2.831 2	3B	2.864 7	2.879 7	2.918 8	2.927 1	0.008 3	3.000 0
3 – 12	UN	2A	0.001 9	2.998 1	2.986 7	2.944 0	2.937 7	0.006 3	2.895 9	2.883 6	2B	2.909 8	2.927 9	2.945 9	2.954 1	0.008 2	3.000 0
		3A	0.000 0	3.000 0	2.988 6	2.945 9	2.941 2	0.004 7	2.897 8	2.887 1	3B	2.909 8	2.919 8	2.945 9	2.952 1	0.006 2	3.000 0
3 – 16	UN	2A	0.001 7	2.998 3	2.988 9	2.957 7	2.952 1	0.005 6	2.921 6	2.911 5	2B	2.932 3	2.946 4	2.959 4	2.966 7	0.007 3	3.000 0
		3A	0.000 0	3.000 0	2.990 6	2.959 4	2.955 2	0.004 2	2.923 3	2.914 6	3B	2.932 3	2.940 8	2.959 4	2.964 9	0.005 5	3.000 0
3 – 20	UN	2A	0.001 6	2.998 4	2.990 3	2.965 9	2.960 7	0.005 2	2.937 1	2.928 3	2B	2.945 9	2.957 4	2.967 5	2.974 3	0.006 8	3.000 0
		3A	0.000 0	3.000 0	2.991 9	2.967 5	2.963 6	0.003 9	2.938 7	2.931 2	3B	2.945 9	2.953 7	2.967 5	2.972 6	0.005 1	3.000 0
3 ¹ / ₈ – 4	UN	2A	0.003 2	3.121 8	3.098 0	2.959 4	2.948 6	0.010 8	2.815 1	2.786 3	2B	2.854 4	2.891 9	2.962 6	2.976 6	0.014 0	3.125 0
		3A	0.000 0	3.125 0	3.101 2	2.962 6	2.954 5	0.008 1	2.818 3	2.792 2	3B	2.854 4	2.884 4	2.962 6	2.973 1	0.010 5	3.125 0
3 ¹ / ₈ – 6	UN	2A	0.002 8	3.122 2	3.104 0	3.013 9	3.004 5	0.009 4	2.917 7	2.896 3	2B	2.944 6	2.975 2	3.016 7	3.028 9	0.012 2	3.125 0
		3A	0.000 0	3.125 0	3.106 8	3.016 7	3.009 7	0.007 0	2.920 5	2.901 5	3B	2.944 6	2.964 6	3.016 7	3.025 9	0.009 2	3.125 0

Table 2 Unified screw threads, standard series – Limits of size (continued)

1	2	3	4	5	6	7	8	9	10	11	12	13	14	15	16	17	18
Nominal size and threads per inch	Series designation	External threads									Internal threads						
		Class	Allowance	Major diameter		Effective diameter			Minor diameter		Class	Minor diameter		Effective diameter			Major diameter
				Max.	Min.	Max.	Min.	Tol.	Max.	Min.		Min.	Max.	Min.	Max.	Tol.	Min.
				in	in	in	in	in	in	in		in	in	in	in	in	in
3/8 — 8	UN	2A	0.002 6	3.122 4	3.107 4	3.041 2	3.032 6	0.008 6	2.969 0	2.951 4	2B	2.989 7	3.014 7	3.043 8	3.055 0	0.011 2	3.125 0
		3A	0.000 0	3.125 0	3.110 0	3.043 8	3.037 4	0.006 4	2.971 6	2.956 2	3B	2.989 7	3.004 7	3.043 8	3.052 2	0.008 4	3.125 0
3/8 — 12	UN	2A	0.001 9	3.123 1	3.111 7	3.069 0	3.062 7	0.006 3	3.020 9	3.008 6	2B	3.034 8	3.052 9	3.070 9	3.079 1	0.008 2	3.125 0
		3A	0.000 0	3.125 0	3.113 6	3.070 9	3.066 2	0.004 7	3.022 8	3.012 1	3B	3.034 8	3.044 8	3.070 9	3.077 1	0.006 2	3.125 0
3/8 — 16	UN	2A	0.001 7	3.123 3	3.113 9	3.082 7	3.077 1	0.005 6	3.046 6	3.036 5	2B	3.057 3	3.071 4	3.084 4	3.091 7	0.007 3	3.125 0
		3A	0.000 0	3.125 0	3.115 6	3.084 4	3.080 2	0.004 2	3.048 3	3.039 6	3B	3.057 3	3.065 8	3.084 4	3.089 9	0.005 5	3.125 0
3/4 — 4	UNC	1A	0.003 3	3.246 7	3.211 0	3.084 3	3.068 0	0.016 3	2.940 0	2.905 7	1B	2.979 4	3.016 9	3.087 6	3.108 8	0.021 2	3.250 0
		2A	0.003 3	3.246 7	3.222 9	3.084 3	3.073 4	0.010 9	2.940 0	2.911 1	2B	2.979 4	3.016 9	3.087 6	3.101 7	0.014 1	3.250 0
		3A	0.000 0	3.250 0	3.226 2	3.087 6	3.079 4	0.008 2	2.943 3	2.917 1	3B	2.979 4	3.009 4	3.087 6	3.098 2	0.010 6	3.250 0
3/4 — 6	UN	2A	0.002 8	3.247 2	3.229 0	3.138 9	3.129 4	0.009 5	3.042 7	3.021 2	2B	3.069 6	3.100 2	3.141 7	3.154 0	0.012 3	3.250 0
		3A	0.000 0	3.250 0	3.231 8	3.141 7	3.134 6	0.007 1	3.045 5	3.026 4	3B	3.069 6	3.089 6	3.141 7	3.150 9	0.009 2	3.250 0
3/4 — 8	UN	2A	0.002 6	3.247 4	3.232 4	3.166 2	3.157 5	0.008 7	3.094 0	3.076 3	2B	3.114 7	3.139 7	3.168 8	3.180 1	0.011 3	3.250 0
		3A	0.000 0	3.250 0	3.235 0	3.168 8	3.162 3	0.006 5	3.096 6	3.081 1	3B	3.114 7	3.129 7	3.168 8	3.177 2	0.008 4	3.250 0
3/4 — 12	UN	2A	0.001 9	3.248 1	3.236 7	3.194 0	3.187 7	0.006 3	3.145 9	3.133 6	2B	3.159 8	3.177 9	3.195 9	3.204 1	0.008 2	3.250 0
		3A	0.000 0	3.250 0	3.238 6	3.195 9	3.191 2	0.004 7	3.147 8	3.137 1	3B	3.159 8	3.169 8	3.195 9	3.202 1	0.006 2	3.250 0
3/4 — 16	UN	2A	0.001 7	3.248 3	3.238 9	3.207 7	3.202 1	0.005 6	3.171 6	3.161 5	2B	3.182 3	3.196 4	3.209 4	3.216 7	0.007 3	3.250 0
		3A	0.000 0	3.250 0	3.240 6	3.209 4	3.205 2	0.004 2	3.173 3	3.164 6	3B	3.182 3	3.190 8	3.209 4	3.214 9	0.005 5	3.250 0
3/8 — 4	UN	2A	0.003 3	3.371 7	3.347 9	3.209 3	3.198 3	0.011 0	3.065 0	3.036 0	2B	3.104 4	3.141 9	3.212 6	3.226 8	0.014 2	3.375 0
		3A	0.000 0	3.375 0	3.351 2	3.212 6	3.204 4	0.008 2	3.068 3	3.042 1	3B	3.104 4	3.134 4	3.212 6	3.223 3	0.010 7	3.375 0
3/8 — 6	UN	2A	0.002 9	3.372 1	3.353 9	3.263 8	3.254 3	0.009 5	3.167 6	3.146 1	2B	3.194 6	3.225 2	3.266 7	3.279 1	0.012 4	3.375 0
		3A	0.000 0	3.375 0	3.356 8	3.266 7	3.259 5	0.007 2	3.170 5	3.151 3	3B	3.194 6	3.214 6	3.266 7	3.276 0	0.009 3	3.375 0
3/8 — 8	UN	2A	0.002 6	3.372 4	3.357 4	3.291 2	3.282 4	0.008 8	3.219 0	3.201 2	2B	3.239 7	3.264 7	3.293 8	3.305 2	0.011 4	3.375 0
		3A	0.000 0	3.375 0	3.360 0	3.293 8	3.287 2	0.006 6	3.221 6	3.206 0	3B	3.239 7	3.254 7	3.293 8	3.302 3	0.008 5	3.375 0
3/8 — 12	UN	2A	0.001 9	3.373 1	3.361 7	3.319 0	3.312 6	0.006 4	3.270 9	3.258 5	2B	3.284 8	3.302 9	3.320 9	3.329 3	0.008 4	3.375 0
		3A	0.000 0	3.375 0	3.363 6	3.320 9	3.316 1	0.004 8	3.272 8	3.262 0	3B	3.284 8	3.294 8	3.320 9	3.327 2	0.006 3	3.375 0
3/8 — 16	UN	2A	0.001 7	3.373 3	3.363 9	3.332 7	3.326 9	0.005 8	3.296 6	3.286 3	2B	3.307 3	3.321 4	3.334 4	3.341 9	0.007 5	3.375 0
		3A	0.000 0	3.375 0	3.365 6	3.334 4	3.330 1	0.004 3	3.298 3	3.289 5	3B	3.307 3	3.315 8	3.334 4	3.340 0	0.005 6	3.375 0

Table 2 Unified screw threads, standard series – Limits of size (continued)

1	2	3	4	5	6	7	8	9	10	11	12	13	14	15	16	17	18
Nominal size and threads per inch	Series designation	External threads									Internal threads						
		Class	Allowance	Major diameter		Effective diameter			Minor diameter		Class	Minor diameter		Effective diameter			Major diameter
				Max.	Min.	Max.	Min.	Tol.	Max.	Min.		Min.	Max.	Min.	Max.	Tol.	Min.
				in	in	in	in	in	in	in		in	in	in	in	in	in
3½ — 4	UNC	1A	0.003 3	3.496 7	3.461 0	3.334 3	3.317 7	0.016 6	3.190 0	3.155 4	1B	3.229 4	3.266 9	3.337 6	3.359 1	0.021 5	3.500 0
		2A	0.003 3	3.496 7	3.472 9	3.334 3	3.323 3	0.011 0	3.190 0	3.161 0	2B	3.229 4	3.266 9	3.337 6	3.351 9	0.014 3	3.500 0
		3A	0.000 0	3.500 0	3.476 2	3.337 6	3.329 3	0.008 3	3.193 3	3.167 0	3B	3.229 4	3.259 4	3.337 6	3.348 4	0.010 8	3.500 0
3½ — 6	UN	2A	0.002 9	3.497 1	3.478 9	3.388 8	3.379 2	0.009 6	3.292 6	3.271 0	2B	3.319 6	3.350 2	3.391 7	3.404 2	0.012 5	3.500 0
		3A	0.000 0	3.500 0	3.481 8	3.391 7	3.384 5	0.007 2	3.295 5	3.276 3	3B	3.319 6	3.339 6	3.391 7	3.401 2	0.009 5	3.500 0
3½ — 8	UN	2A	0.002 6	3.497 4	3.482 4	3.416 2	3.407 4	0.008 8	3.344 0	3.326 2	2B	3.364 7	3.389 7	3.418 8	3.430 3	0.011 5	3.500 0
		3A	0.000 0	3.500 0	3.485 0	3.418 8	3.412 2	0.006 6	3.346 6	3.331 0	3B	3.364 7	3.379 7	3.418 8	3.427 4	0.008 6	3.500 0
3½ — 12	UN	2A	0.001 9	3.498 1	3.486 7	3.444 0	3.437 6	0.006 4	3.395 9	3.383 5	2B	3.409 8	3.427 9	3.445 9	3.454 3	0.008 4	3.500 0
		3A	0.000 0	3.500 0	3.488 6	3.445 9	3.441 1	0.004 8	3.397 8	3.387 0	3B	3.409 8	3.419 8	3.445 9	3.452 2	0.006 3	3.500 0
3½ — 16	UN	2A	0.001 7	3.498 3	3.488 9	3.457 7	3.451 9	0.005 8	3.421 6	3.411 3	2B	3.432 3	3.446 4	3.459 4	3.466 9	0.007 5	3.500 0
		3A	0.000 0	3.500 0	3.490 6	3.459 4	3.455 1	0.004 8	3.423 3	3.414 5	3B	3.432 3	3.440 8	3.459 4	3.465 0	0.005 6	3.500 0
3⅝ — 4	UN	2A	0.003 3	3.621 7	3.597 9	3.459 3	3.448 2	0.011 1	3.315 0	3.285 9	2B	3.354 4	3.391 9	3.462 6	3.477 0	0.014 4	3.625 0
		3A	0.000 0	3.625 0	3.601 2	3.462 6	3.454 3	0.008 3	3.318 3	3.292 0	3B	3.354 4	3.384 4	3.462 6	3.473 4	0.010 8	3.625 0
3⅝ — 6	UN	2A	0.002 9	3.622 1	3.603 9	3.513 8	3.504 1	0.009 7	3.417 6	3.395 9	2B	3.444 6	3.475 2	3.516 7	3.529 3	0.012 6	3.625 0
		3A	0.000 0	3.625 0	3.606 8	3.516 7	3.509 4	0.007 3	3.420 5	3.401 2	3B	3.444 6	3.464 6	3.516 7	3.526 2	0.009 5	3.625 0
3⅝ — 8	UN	2A	0.002 7	3.622 3	3.607 3	3.541 1	3.532 2	0.008 9	3.468 9	3.451 0	2B	3.489 7	3.514 7	3.543 8	3.555 4	0.011 6	3.625 0
		3A	0.000 0	3.625 0	3.610 0	3.543 8	3.537 1	0.006 7	3.471 6	3.455 9	3B	3.489 7	3.504 7	3.543 8	3.552 5	0.008 7	3.625 0
3⅝ — 12	UN	2A	0.001 9	3.623 1	3.611 7	3.569 0	3.562 6	0.006 4	3.520 9	3.508 5	2B	3.534 8	3.552 9	3.570 9	3.579 3	0.008 4	3.625 0
		3A	0.000 0	3.625 0	3.613 6	3.570 9	3.566 1	0.004 8	3.522 8	3.512 0	3B	3.534 8	3.544 8	3.570 9	3.577 2	0.006 3	3.625 0
3⅝ — 16	UN	2A	0.001 7	3.623 3	3.613 9	3.582 7	3.576 9	0.005 8	3.546 6	3.536 3	2B	3.557 3	3.571 4	3.584 4	3.591 9	0.007 5	3.625 0
		3A	0.000 0	3.625 0	3.615 6	3.584 4	3.580 1	0.004 3	3.548 3	3.539 5	3B	3.557 3	3.565 8	3.584 4	3.590 0	0.005 6	3.625 0
3¾ — 4	UNC	1A	0.003 4	3.746 6	3.710 9	3.584 2	3.567 4	0.016 8	3.439 9	3.405 1	1B	3.479 4	3.516 9	3.587 6	3.609 4	0.021 8	3.750 0
		2A	0.003 4	3.746 6	3.722 8	3.584 2	3.573 0	0.011 2	3.439 9	3.410 7	2B	3.479 4	3.516 9	3.587 6	3.602 1	0.014 5	3.750 0
		3A	0.000 0	3.750 0	3.726 2	3.587 6	3.579 2	0.008 4	3.443 3	3.416 9	3B	3.479 4	3.509 4	3.587 6	3.598 5	0.010 9	3.750 0
3¾ — 6	UN	2A	0.002 9	3.747 1	3.728 9	3.638 8	3.629 0	0.009 8	3.542 6	3.520 8	2B	3.569 6	3.600 2	3.641 7	3.654 4	0.012 7	3.750 0
		3A	0.000 0	3.750 0	3.731 8	3.641 7	3.634 4	0.007 3	3.545 5	3.526 2	3B	3.569 6	3.589 6	3.641 7	3.651 2	0.009 5	3.750 0
3¾ — 8	UN	2A	0.002 7	3.747 3	3.732 3	3.666 1	3.657 1	0.009 0	3.593 9	3.575 9	2B	3.614 7	3.639 7	3.668 8	3.680 5	0.011 7	3.750 0
		3A	0.000 0	3.750 0	3.735 0	3.668 8	3.662 1	0.006 7	3.596 6	3.580 9	3B	3.614 7	3.629 7	3.668 8	3.677 6	0.008 8	3.750 0

Table 2 Unified screw threads, standard series – Limits of size (continued)

1	2	3	4	5	6	7	8	9	10	11	12	13	14	15	16	17	18
Nominal size and threads per inch	Series designation	External threads									Internal threads						
		Class	Allowance	Major diameter		Effective diameter			Minor diameter		Class	Minor diameter		Effective diameter			Major diameter
				Max.	Min.	Max.	Min.	Tol.	Max.	Min.		Min.	Max.	Min.	Max.	Tol.	Min.
				in	in	in	in	in	in	in		in	in	in	in	in	in
3/4—12	UN	2A	0.001 9	3.748 1	3.736 7	3.694 0	3.687 6	0.006 4	3.645 9	3.633 5	2B	3.659 8	3.677 9	3.695 9	3.704 3	0.008 4	3.750 0
		3A	0.000 0	3.750 0	3.738 6	3.695 9	3.691 1	0.004 8	3.647 8	3.637 0	3B	3.659 8	3.669 8	3.695 9	3.702 2	0.006 3	3.750 0
3/4—16	UN	2A	0.001 7	3.748 3	3.738 9	3.707 7	3.701 9	0.005 8	3.671 6	3.661 3	2B	3.682 3	3.696 4	3.709 4	3.716 9	0.007 5	3.750 0
		3A	0.000 0	3.750 0	3.740 6	3.709 4	3.705 1	0.004 3	3.673 3	3.664 5	3B	3.682 3	3.690 8	3.709 4	3.715 0	0.005 6	3.750 0
3/8—4	UN	2A	0.003 4	3.871 6	3.847 8	3.709 2	3.697 9	0.011 3	3.564 9	3.535 6	2B	3.604 4	3.641 9	3.712 6	3.727 2	0.014 6	3.875 0
		3A	0.000 0	3.875 0	3.851 2	3.712 6	3.704 1	0.008 5	3.568 3	3.541 8	3B	3.604 4	3.634 4	3.712 6	3.723 6	0.011 0	3.875 0
3/8—6	UN	2A	0.003 0	3.872 0	3.853 8	3.763 7	3.753 8	0.009 9	3.667 5	3.645 6	2B	3.694 6	3.725 2	3.766 7	3.779 5	0.012 8	3.875 0
		3A	0.000 0	3.875 0	3.856 8	3.766 7	3.759 3	0.007 4	3.670 5	3.651 1	3B	3.694 6	3.714 6	3.766 7	3.776 3	0.009 6	3.875 0
3/8—8	UN	2A	0.002 7	3.872 3	3.857 3	3.791 1	3.782 0	0.009 1	3.718 9	3.700 8	2B	3.739 7	3.764 7	3.793 8	3.805 6	0.011 8	3.875 0
		3A	0.000 0	3.875 0	3.860 0	3.793 8	3.787 0	0.006 8	3.721 6	3.705 8	3B	3.739 7	3.754 7	3.793 8	3.802 6	0.008 8	3.875 0
3/8—12	UN	2A	0.002 0	3.873 0	3.861 6	3.818 9	3.812 4	0.006 5	3.770 8	3.758 3	2B	3.784 8	3.802 9	3.820 9	3.829 4	0.008 5	3.875 0
		3A	0.000 0	3.875 0	3.863 6	3.820 9	3.816 0	0.004 9	3.772 8	3.761 9	3B	3.784 8	3.794 8	3.820 9	3.827 3	0.006 4	3.875 0
3/8—16	UN	2A	0.001 8	3.873 2	3.863 8	3.832 6	3.826 7	0.005 9	3.796 5	3.786 1	2B	3.807 3	3.821 4	3.834 4	3.842 0	0.007 6	3.875 0
		3A	0.000 0	3.875 0	3.865 6	3.834 4	3.830 0	0.004 4	3.798 3	3.789 4	3B	3.807 3	3.815 8	3.834 4	3.840 1	0.005 7	3.875 0
4—4	UNC	1A	0.003 4	3.996 6	3.960 9	3.834 2	3.817 2	0.017 0	3.689 9	3.654 9	1B	3.729 4	3.766 9	3.837 6	3.859 7	0.022 1	4.000 0
		2A	0.003 4	3.996 6	3.972 8	3.834 2	3.822 9	0.011 3	3.689 9	3.660 6	2B	3.729 4	3.766 9	3.837 6	3.852 3	0.014 7	4.000 0
		3A	0.000 0	4.000 0	3.976 2	3.837 6	3.829 1	0.008 5	3.693 3	3.666 8	3B	3.729 4	3.759 4	3.837 6	3.848 7	0.011 1	4.000 0
4—6	UN	2A	0.003 0	3.997 0	3.978 8	3.888 7	3.878 8	0.009 9	3.792 5	3.770 6	2B	3.819 6	3.850 2	3.891 7	3.904 6	0.012 9	4.000 0
		3A	0.000 0	4.000 0	3.981 8	3.891 7	3.884 3	0.007 4	3.795 5	3.776 1	3B	3.819 6	3.839 6	3.891 7	3.901 4	0.009 7	4.000 0
4—8	UN	2A	0.002 7	3.997 3	3.982 3	3.916 1	3.907 0	0.009 1	3.843 9	3.825 8	2B	3.864 7	3.889 7	3.918 8	3.930 7	0.011 9	4.000 0
		3A	0.000 0	4.000 0	3.985 0	3.918 8	3.912 0	0.006 8	3.846 6	3.830 8	3B	3.864 7	3.879 7	3.918 8	3.927 7	0.008 9	4.000 0
4—12	UN	2A	0.002 0	3.998 0	3.986 6	3.943 9	3.937 4	0.006 5	3.895 8	3.883 3	2B	3.909 8	3.927 9	3.945 9	3.954 4	0.008 5	4.000 0
		3A	0.000 0	4.000 0	3.988 6	3.945 9	3.941 0	0.004 9	3.897 8	3.886 9	3B	3.909 8	3.919 8	3.945 9	3.952 3	0.006 4	4.000 0
4—16	UN	2A	0.001 8	3.998 2	3.988 8	3.957 6	3.951 7	0.005 9	3.921 5	3.911 1	2B	3.932 3	3.946 4	3.959 4	3.967 0	0.007 6	4.000 0
		3A	0.000 0	4.000 0	3.990 6	3.959 4	3.955 0	0.004 4	3.923 3	3.914 4	3B	3.932 3	3.940 8	3.959 4	3.965 1	0.005 7	4.000 0
4 1/8—4	UN	2A	0.003 4	4.121 6	4.097 8	3.959 2	3.947 8	0.011 4	3.814 9	3.785 5	2B	3.854 4	3.891 9	3.962 6	3.977 4	0.014 8	4.125 0
		3A	0.000 0	4.125 0	4.101 2	3.962 6	3.954 0	0.008 6	3.818 3	3.791 7	3B	3.854 4	3.884 4	3.962 6	3.973 7	0.011 1	4.125 0

Table 2 Unified screw threads, standard series – Limits of size (continued)

1	2	3	4	5	6	7	8	9	10	11	12	13	14	15	16	17	18
Nominal size and threads per inch	Series designation	External threads									Internal threads						
		Class	Allowance	Major diameter		Effective diameter			Minor diameter		Class	Minor diameter		Effective diameter			Major diameter
				Max.	Min.	Max.	Min.	Tol.	Max.	Min.		Min.	Max.	Min.	Max.	Tol.	Min.
				in	in	in	in	in	in	in		in	in	in	in	in	in
4 $\frac{1}{8}$ —6	UN	2A	0.003 0	4.122 0	4.103 8	4.013 7	4.003 7	0.010 0	3.917 5	3.895 5	2B	3.944 6	3.975 2	4.016 7	4.029 7	0.013 0	4.125 0
		3A	0.000 0	4.125 0	4.106 8	4.016 7	4.009 2	0.007 5	3.920 5	3.901 0	3B	3.944 6	3.964 6	4.016 7	4.026 4	0.009 7	4.125 0
4 $\frac{1}{8}$ —8	UN	2A	0.002 8	4.122 2	4.107 2	4.041 0	4.031 8	0.009 2	3.968 8	3.950 6	2B	3.989 7	4.014 7	4.043 8	4.055 8	0.012 0	4.125 0
		3A	0.000 0	4.125 0	4.110 0	4.043 8	4.036 9	0.006 9	3.971 6	3.955 7	3B	3.989 7	4.004 7	4.043 8	4.052 8	0.009 0	4.125 0
4 $\frac{1}{8}$ —12	UN	2A	0.002 0	4.123 0	4.111 6	4.068 9	4.062 4	0.006 5	4.020 8	4.008 3	2B	4.034 8	4.052 9	4.070 9	4.079 4	0.008 5	4.125 0
		3A	0.000 0	4.125 0	4.113 6	4.070 9	4.066 0	0.004 9	4.022 8	4.011 9	3B	4.034 8	4.044 8	4.070 9	4.077 3	0.006 4	4.125 0
4 $\frac{1}{8}$ —16	UN	2A	0.001 8	4.123 2	4.113 8	4.082 6	4.076 7	0.005 9	4.046 5	4.036 1	2B	4.057 3	4.071 4	4.084 4	4.092 0	0.007 6	4.125 0
		3A	0.000 0	4.125 0	4.115 6	4.084 4	4.080 0	0.004 4	4.048 3	4.039 4	3B	4.057 3	4.065 8	4.084 4	4.090 1	0.005 7	4.125 0
4 $\frac{1}{4}$ —4	UN	2A	0.003 4	4.246 6	4.222 8	4.084 2	4.072 7	0.011 5	3.939 9	3.910 4	2B	3.979 4	4.016 9	4.087 6	4.102 5	0.014 9	4.250 0
		3A	0.000 0	4.250 0	4.226 2	4.087 6	4.079 0	0.008 6	3.943 3	3.916 7	3B	3.979 4	4.009 4	4.087 6	4.098 8	0.011 2	4.250 0
4 $\frac{1}{4}$ —6	UN	2A	0.003 0	4.247 0	4.228 8	4.138 7	4.128 6	0.010 1	4.042 5	4.020 4	2B	4.069 6	4.100 2	4.141 7	4.154 8	0.013 1	4.250 0
		3A	0.000 0	4.250 0	4.231 8	4.141 7	4.134 2	0.007 5	4.045 5	4.026 0	3B	4.069 6	4.089 6	4.141 7	4.151 5	0.009 8	4.250 0
4 $\frac{1}{4}$ —8	UN	2A	0.002 8	4.247 2	4.232 2	4.166 0	4.156 7	0.009 3	4.093 8	4.075 5	2B	4.114 7	4.139 7	4.168 8	4.180 9	0.012 1	4.250 0
		3A	0.000 0	4.250 0	4.235 0	4.168 8	4.161 8	0.007 0	4.096 6	4.080 6	3B	4.114 7	4.129 7	4.168 8	4.177 8	0.009 0	4.250 0
4 $\frac{1}{4}$ —12	UN	2A	0.002 0	4.248 0	4.236 6	4.193 9	4.187 4	0.006 5	4.145 8	4.133 3	2B	4.159 8	4.177 9	4.195 9	4.204 4	0.008 5	4.250 0
		3A	0.000 0	4.250 0	4.238 6	4.195 9	4.191 0	0.004 9	4.147 8	4.136 9	3B	4.159 8	4.169 8	4.195 9	4.202 3	0.006 4	4.250 0
4 $\frac{1}{4}$ —16	UN	2A	0.001 8	4.248 2	4.238 8	4.207 6	4.201 7	0.005 9	4.171 5	4.161 1	2B	4.182 3	4.196 4	4.209 4	4.217 0	0.007 6	4.250 0
		3A	0.000 0	4.250 0	4.240 6	4.209 4	4.205 0	0.004 4	4.173 3	4.164 4	3B	4.182 3	4.190 8	4.209 4	4.215 1	0.005 7	4.250 0
4 $\frac{3}{8}$ —4	UN	2A	0.003 5	4.371 5	4.347 7	4.209 1	4.197 6	0.011 5	4.064 8	4.035 3	2B	4.104 4	4.141 9	4.212 6	4.227 6	0.015 0	4.375 0
		3A	0.000 0	4.375 0	4.351 2	4.212 6	4.203 9	0.008 7	4.068 3	4.041 6	3B	4.104 4	4.134 4	4.212 6	4.223 8	0.011 2	4.375 0
4 $\frac{3}{8}$ —6	UN	2A	0.003 0	4.372 0	4.353 8	4.263 7	4.253 6	0.010 1	4.167 5	4.145 4	2B	4.194 6	4.225 2	4.266 7	4.279 9	0.013 2	4.375 0
		3A	0.000 0	4.375 0	4.356 8	4.266 7	4.259 1	0.007 6	4.170 5	4.150 9	3B	4.194 6	4.214 6	4.266 7	4.276 6	0.009 9	4.375 0
4 $\frac{3}{8}$ —8	UN	2A	0.002 8	4.372 2	4.357 2	4.291 0	4.281 7	0.009 3	4.218 8	4.200 5	2B	4.239 7	4.264 7	4.293 8	4.305 9	0.012 1	4.375 0
		3A	0.000 0	4.375 0	4.360 0	4.293 8	4.286 8	0.007 0	4.221 6	4.205 6	3B	4.239 7	4.254 7	4.293 8	4.302 9	0.009 1	4.375 0
4 $\frac{3}{8}$ —12	UN	2A	0.002 0	4.373 0	4.361 6	4.318 9	4.312 4	0.006 5	4.270 8	4.258 3	2B	4.284 8	4.302 9	4.320 9	4.329 4	0.008 5	4.375 0
		3A	0.000 0	4.375 0	4.363 6	4.320 9	4.316 0	0.004 9	4.272 8	4.261 9	3B	4.284 8	4.294 8	4.320 9	4.327 3	0.006 4	4.375 0
4 $\frac{3}{8}$ —16	UN	2A	0.001 8	4.373 2	4.363 8	4.332 6	4.326 7	0.005 9	4.296 5	4.286 1	2B	4.307 3	4.321 4	4.334 4	4.342 0	0.007 6	4.375 0
		3A	0.000 0	4.375 0	4.365 6	4.334 4	4.330 0	0.004 4	4.298 3	4.289 4	3B	4.307 3	4.315 8	4.334 4	4.340 1	0.005 7	4.375 0

Table 2 Unified screw threads, standard series – Limits of size (continued)

1	2	3	4	5	6	7	8	9	10	11	12	13	14	15	16	17	18
Nominal size and threads per inch	Series designation	External threads									Internal threads						
		Class	Allowance	Major diameter		Effective diameter			Minor diameter		Class	Minor diameter		Effective diameter			Major diameter
				Max.	Min.	Max.	Min.	Tol.	Max.	Min.		Min.	Max.	Min.	Max.	Tol.	Min.
in	in	in	in	in	in	in	in	in	in	in	in	in	in	in	in	in	in
4½ — 4	UN	2A	0.003 5	4.496 5	4.472 7	4.334 1	4.322 5	0.011 6	4.189 8	4.160 2	2B	4.229 4	4.266 9	4.337 6	4.352 7	0.015 1	4.500 0
		3A	0.000 0	4.500 0	4.476 2	4.337 6	4.328 9	0.008 7	4.193 3	4.166 6	3B	4.229 4	4.259 4	4.337 6	4.348 9	0.011 3	4.500 0
4½ — 6	UN	2A	0.003 1	4.496 9	4.478 7	4.388 6	4.378 4	0.010 2	4.292 4	4.270 2	2B	4.319 6	4.350 2	4.391 7	4.405 0	0.013 3	4.500 0
		3A	0.000 0	4.500 0	4.481 8	4.391 7	4.384 0	0.007 7	4.295 5	4.275 8	3B	4.319 6	4.339 6	4.391 7	4.401 6	0.009 9	4.500 0
4½ — 8	UN	2A	0.002 8	4.497 2	4.482 2	4.416 0	4.406 6	0.009 4	4.343 8	4.325 4	2B	4.364 7	4.389 7	4.418 8	4.431 0	0.012 2	4.500 0
		3A	0.000 0	4.500 0	4.485 0	4.418 8	4.411 7	0.007 1	4.346 6	4.330 5	3B	4.364 7	4.379 7	4.418 8	4.428 0	0.009 2	4.500 0
4½ — 12	UN	2A	0.002 0	4.498 0	4.486 6	4.443 9	4.437 4	0.006 5	4.395 8	4.383 3	2B	4.409 8	4.427 9	4.445 9	4.454 4	0.008 5	4.500 0
		3A	0.000 0	4.500 0	4.488 6	4.445 9	4.441 0	0.004 9	4.397 8	4.386 9	3B	4.409 8	4.419 8	4.445 9	4.452 3	0.006 4	4.500 0
4½ — 16	UN	2A	0.001 8	4.498 2	4.488 8	4.457 6	4.451 7	0.005 9	4.421 5	4.411 1	2B	4.432 3	4.446 4	4.459 4	4.467 0	0.007 6	4.500 0
		3A	0.000 0	4.500 0	4.490 6	4.459 4	4.455 0	0.004 4	4.423 3	4.414 4	3B	4.432 3	4.440 8	4.459 4	4.465 1	0.005 7	4.500 0
4⅝ — 4	UN	2A	0.003 5	4.621 5	4.597 7	4.459 1	4.447 4	0.011 7	4.314 8	4.285 1	2B	4.354 4	4.391 9	4.462 6	4.477 8	0.015 2	4.625 0
		3A	0.000 0	4.625 0	4.601 2	4.462 6	4.453 8	0.008 8	4.318 3	4.291 5	3B	4.354 4	4.384 4	4.462 6	4.474 0	0.011 4	4.625 0
4⅝ — 6	UN	2A	0.003 1	4.621 9	4.603 7	4.513 6	4.503 3	0.010 3	4.417 4	4.395 1	2B	4.444 6	4.475 2	4.516 7	4.530 0	0.013 3	4.625 0
		3A	0.000 0	4.625 0	4.606 8	4.516 7	4.509 0	0.007 7	4.420 5	4.400 8	3B	4.444 6	4.464 6	4.516 7	4.526 7	0.010 0	4.625 0
4⅝ — 8	UN	2A	0.002 8	4.622 2	4.607 2	4.541 0	4.531 5	0.009 5	4.468 8	4.450 3	2B	4.489 7	4.514 7	4.543 8	4.556 1	0.012 3	4.625 0
		3A	0.000 0	4.625 0	4.610 0	4.543 8	4.536 7	0.007 1	4.471 6	4.455 5	3B	4.489 7	4.504 7	4.545 8	4.553 0	0.009 2	4.625 0
4⅝ — 12	UN	2A	0.002 0	4.623 0	4.611 6	4.568 9	4.562 2	0.006 7	4.520 8	4.508 1	2B	4.534 8	4.552 9	4.570 9	4.579 6	0.008 7	4.625 0
		3A	0.000 0	4.625 0	4.613 6	4.570 9	4.565 9	0.005 0	4.522 8	4.511 8	3B	4.534 8	4.544 8	4.570 9	4.577 5	0.006 6	4.625 0
4⅝ — 16	UN	2A	0.001 8	4.623 2	4.613 8	4.582 6	4.576 5	0.006 1	4.546 5	4.535 9	2B	4.557 3	4.571 4	4.584 4	4.592 3	0.007 9	4.625 0
		3A	0.000 0	4.625 0	4.615 6	4.584 4	4.579 9	0.004 5	4.548 3	4.539 3	3B	4.557 3	4.565 8	4.584 4	4.590 3	0.005 9	4.625 0
4¾ — 4	UN	2A	0.003 5	4.746 5	4.722 7	4.584 1	4.572 4	0.011 7	4.439 8	4.410 1	2B	4.479 4	4.516 9	4.587 6	4.602 9	0.015 3	4.750 0
		3A	0.000 0	4.750 0	4.726 2	4.587 6	4.578 8	0.008 8	4.443 3	4.416 5	3B	4.479 4	4.509 4	4.587 6	4.599 0	0.011 4	4.750 0
4¾ — 6	UN	2A	0.003 1	4.746 9	4.728 7	4.638 6	4.628 3	0.010 3	4.542 4	4.520 1	2B	4.569 6	4.600 2	4.641 7	4.655 1	0.013 4	4.750 0
		3A	0.000 0	4.750 0	4.731 8	4.641 7	4.634 0	0.007 7	4.545 5	4.525 8	3B	4.569 6	4.589 6	4.641 7	4.651 8	0.010 1	4.750 0
4¾ — 8	UN	2A	0.002 9	4.747 1	4.732 1	4.665 9	4.656 4	0.009 5	4.593 7	4.575 2	2B	4.614 7	4.639 7	4.668 8	4.681 2	0.012 4	4.750 0
		3A	0.000 0	4.750 0	4.735 0	4.668 8	4.661 6	0.007 2	4.596 6	4.580 4	3B	4.614 7	4.629 7	4.668 8	4.678 1	0.009 3	4.750 0
4¾ — 12	UN	2A	0.002 0	4.748 0	4.736 6	4.693 9	4.687 2	0.006 7	4.645 8	4.633 1	2B	4.659 8	4.677 9	4.695 9	4.704 6	0.008 7	4.750 0
		3A	0.000 0	4.750 0	4.738 6	4.695 9	4.690 9	0.005 0	4.647 8	4.636 8	3B	4.659 8	4.669 8	4.695 9	4.702 5	0.006 6	4.750 0

Table 2 Unified screw threads, standard series – Limits of size (continued)

1	2	3	4	5	6	7	8	9	10	11	12	13	14	15	16	17	18
Nominal size and threads per inch	Series designation	External threads									Internal threads						
		Class	Allowance	Major diameter		Effective diameter			Minor diameter		Class	Minor diameter		Effective diameter			Major diameter
				Max.	Min.	Max.	Min.	Tol.	Max.	Min.		Min.	Max.	Min.	Max.	Tol.	Min.
				in	in	in	in	in	in	in		in	in	in	in	in	in
4 $\frac{3}{4}$ — 16	UN	2A	0.001 8	4.748 2	4.738 8	4.707 6	4.701 5	0.006 1	4.671 5	4.660 9	2B	4.682 3	4.696 4	4.709 4	4.717 3	0.007 9	4.750 0
		3A	0.000 0	4.750 0	4.740 6	4.709 4	4.704 9	0.004 5	4.673 3	4.664 3	3B	4.682 3	4.690 8	4.709 4	4.715 3	0.005 9	4.750 0
4 $\frac{7}{8}$ — 4	UN	2A	0.003 5	4.871 5	4.847 7	4.709 1	4.697 3	0.011 8	4.564 8	4.535 0	2B	4.604 4	4.641 9	4.712 6	4.728 0	0.015 4	4.875 0
		3A	0.000 0	4.875 0	4.851 2	4.712 6	4.703 7	0.008 9	4.568 3	4.541 4	3B	4.604 4	4.634 4	4.712 6	4.724 1	0.011 5	4.875 0
4 $\frac{7}{8}$ — 6	UN	2A	0.003 1	4.871 9	4.853 7	4.763 6	4.753 2	0.010 4	4.667 4	4.645 0	2B	4.694 6	4.725 2	4.766 7	4.780 2	0.013 5	4.875 0
		3A	0.000 0	4.875 0	4.856 8	4.766 7	4.758 9	0.007 8	4.670 5	4.650 7	3B	4.694 6	4.714 6	4.766 7	4.776 8	0.010 1	4.875 0
4 $\frac{7}{8}$ — 8	UN	2A	0.002 9	4.872 1	4.857 1	4.790 9	4.781 3	0.009 6	4.718 7	4.700 1	2B	4.739 7	4.764 7	4.793 8	4.806 3	0.012 5	4.875 0
		3A	0.000 0	4.875 0	4.860 0	4.793 8	4.786 6	0.007 2	4.721 6	4.705 4	3B	4.739 7	4.754 7	4.793 8	4.803 2	0.009 4	4.875 0
4 $\frac{7}{8}$ — 12	UN	2A	0.002 0	4.873 0	4.861 6	4.818 9	4.812 2	0.006 7	4.770 8	4.758 1	2B	4.784 8	4.802 9	4.820 9	4.829 6	0.008 7	4.875 0
		3A	0.000 0	4.875 0	4.863 6	4.820 9	4.815 9	0.005 0	4.772 8	4.761 8	3B	4.784 8	4.794 8	4.820 9	4.827 5	0.006 6	4.875 0
4 $\frac{7}{8}$ — 16	UN	2A	0.001 8	4.873 2	4.863 8	4.832 6	4.826 5	0.006 1	4.796 5	4.785 9	2B	4.807 3	4.821 4	4.834 4	4.842 3	0.007 9	4.875 0
		3A	0.000 0	4.875 0	4.865 6	4.834 4	4.829 9	0.004 5	4.798 3	4.789 3	3B	4.807 3	4.815 8	4.834 4	4.840 3	0.005 9	4.875 0
5 — 4	UN	2A	0.003 6	4.996 4	4.972 6	4.834 0	4.822 1	0.011 9	4.689 7	4.659 8	2B	4.729 4	4.766 9	4.837 6	4.853 0	0.015 4	5.000 0
		3A	0.000 0	5.000 0	4.976 2	4.837 6	4.828 7	0.008 9	4.693 3	4.666 4	3B	4.729 4	4.759 4	4.837 6	4.849 2	0.011 6	5.000 0
5 — 6	UN	2A	0.003 1	4.996 9	4.978 7	4.888 6	4.878 1	0.010 5	4.792 4	4.769 9	2B	4.819 6	4.850 2	4.891 7	4.905 3	0.013 6	5.000 0
		3A	0.000 0	5.000 0	4.981 8	4.891 7	4.883 9	0.007 8	4.795 5	4.775 7	3B	4.819 6	4.839 6	4.891 7	4.901 9	0.010 2	5.000 0
5 — 8	UN	2A	0.002 9	4.997 1	4.982 1	4.915 9	4.906 2	0.009 7	4.843 7	4.825 0	2B	4.864 7	4.889 7	4.918 8	4.931 4	0.012 6	5.000 0
		3A	0.000 0	5.000 0	4.985 0	4.918 8	4.911 5	0.007 3	4.846 6	4.830 3	3B	4.864 7	4.879 7	4.918 8	4.928 2	0.009 4	5.000 0
5 — 12	UN	2A	0.002 0	4.998 0	4.986 6	4.943 9	4.937 2	0.006 7	4.895 8	4.883 1	2B	4.909 8	4.927 9	4.945 9	4.954 6	0.008 7	5.000 0
		3A	0.000 0	5.000 0	4.988 6	4.945 9	4.940 9	0.005 0	4.897 8	4.886 8	3B	4.909 8	4.919 8	4.945 9	4.952 5	0.006 6	5.000 0
5 — 16	UN	2A	0.001 8	4.998 2	4.988 8	4.957 6	4.951 5	0.006 1	4.921 5	4.910 9	2B	4.932 3	4.946 4	4.959 4	4.967 3	0.007 9	5.000 0
		3A	0.000 0	5.000 0	4.990 6	4.959 4	4.954 9	0.004 5	4.923 3	4.914 3	3B	4.932 3	4.940 8	4.959 4	4.965 3	0.005 9	5.000 0
5 $\frac{1}{8}$ — 4	UN	2A	0.003 6	5.121 4	5.097 6	4.959 0	4.947 1	0.011 9	4.814 7	4.784 8	2B	4.854 4	4.891 9	4.962 6	4.978 1	0.015 5	5.125 0
		3A	0.000 0	5.125 0	5.101 2	4.962 6	4.953 6	0.009 0	4.818 3	4.791 3	3B	4.854 4	4.884 4	4.962 6	4.974 2	0.011 6	5.125 0
5 $\frac{1}{8}$ — 6	UN	2A	0.003 2	5.121 8	5.103 6	5.013 5	5.003 0	0.010 5	4.917 3	4.894 8	2B	4.944 6	4.975 2	5.016 7	5.030 4	0.013 7	5.125 0
		3A	0.000 0	5.125 0	5.106 8	5.016 7	5.008 8	0.007 9	4.920 5	4.900 6	3B	4.944 6	4.964 6	5.016 7	5.027 0	0.010 3	5.125 0

Table 2 Unified screw threads, standard series – Limits of size (continued)

1	2	3	4	5	6	7	8	9	10	11	12	13	14	15	16	17	18
Nominal size and threads per inch	Series designation	External threads									Internal threads						
		Class	Allowance	Major diameter		Effective diameter			Minor diameter		Class	Minor diameter		Effective diameter			Major diameter
				Max.	Min.	Max.	Min.	Tol.	Max.	Min.		Min.	Max.	Min.	Max.	Tol.	Min.
				in	in	in	in	in	in	in		in	in	in	in	in	in
5/8 — 8	UN	2A	0.002 9	5.122 1	5.107 1	5.040 9	5.031 2	0.009 7	4.968 7	4.950 0	2B	4.989 7	5.014 7	5.043 8	5.056 5	0.012 7	5.125 0
		3A	0.000 0	5.125 0	5.110 0	5.043 8	5.036 5	0.007 3	4.971 6	4.955 3	3B	4.989 7	5.004 7	5.043 8	5.053 3	0.009 5	5.125 0
5/8 — 12	UN	2A	0.002 0	5.123 0	5.111 6	5.068 9	5.062 2	0.006 7	5.020 8	5.008 1	2B	5.034 8	5.052 9	5.070 9	5.079 6	0.008 7	5.125 0
		3A	0.000 0	5.125 0	5.113 6	5.070 9	5.065 9	0.005 0	5.022 8	5.011 8	3B	5.034 8	5.044 8	5.070 9	5.077 5	0.006 6	5.125 0
5/8 — 16	UN	2A	0.001 8	5.123 2	5.113 8	5.082 6	5.076 5	0.006 1	5.046 5	5.035 9	2B	5.057 3	5.071 4	5.084 4	5.092 3	0.007 9	5.125 0
		3A	0.000 0	5.125 0	5.115 6	5.084 4	5.079 9	0.004 5	5.048 3	5.039 3	3B	5.057 3	5.065 8	5.084 4	5.090 3	0.005 9	5.125 0
5/4 — 4	UN	2A	0.003 6	5.246 4	5.222 6	5.084 0	5.072 0	0.012 0	4.939 7	4.909 7	2B	4.979 4	5.016 9	5.087 6	5.103 2	0.015 6	5.250 0
		3A	0.000 0	5.250 0	5.226 2	5.087 6	5.078 6	0.009 0	4.943 3	4.916 3	3B	4.979 4	5.009 4	5.087 6	5.099 3	0.011 7	5.250 0
5/4 — 6	UN	2A	0.003 2	5.246 8	5.228 6	5.138 5	5.127 9	0.010 6	5.042 3	5.019 7	2B	5.069 6	5.100 2	5.141 7	5.155 5	0.013 8	5.250 0
		3A	0.000 0	5.250 0	5.231 8	5.141 7	5.133 8	0.007 9	5.045 5	5.025 6	3B	5.069 6	5.089 6	5.141 7	5.152 0	0.010 3	5.250 0
5/4 — 8	UN	2A	0.002 9	5.247 1	5.232 1	5.165 9	5.156 1	0.009 8	5.093 7	5.074 9	2B	5.114 7	5.139 7	5.168 8	5.181 5	0.012 7	5.250 0
		3A	0.000 0	5.250 0	5.235 0	5.168 8	5.161 5	0.007 3	5.096 6	5.080 3	3B	5.114 7	5.129 7	5.168 8	5.178 3	0.009 5	5.250 0
5/4 — 12	UN	2A	0.002 0	5.248 0	5.236 6	5.193 9	5.187 2	0.006 7	5.145 8	5.133 1	2B	5.159 8	5.177 9	5.195 9	5.204 6	0.008 7	5.250 0
		3A	0.000 0	5.250 0	5.238 6	5.195 9	5.190 9	0.005 0	5.147 8	5.136 8	3B	5.159 8	5.169 8	5.195 9	5.202 5	0.006 6	5.250 0
5/4 — 16	UN	2A	0.001 8	5.248 2	5.238 8	5.207 6	5.201 5	0.006 1	5.171 5	5.160 9	2B	5.182 3	5.196 4	5.209 4	5.217 3	0.007 9	5.250 0
		3A	0.000 0	5.250 0	5.240 6	5.209 4	5.204 9	0.004 5	5.173 3	5.164 3	3B	5.182 3	5.190 8	5.209 4	5.215 3	0.005 9	5.250 0
5/8 — 4	UN	2A	0.003 6	5.371 4	5.347 6	5.209 0	5.196 9	0.012 1	5.064 7	5.034 6	2B	5.104 4	5.141 9	5.212 6	5.228 3	0.015 7	5.375 0
		3A	0.000 0	5.375 0	5.351 2	5.212 6	5.203 6	0.009 0	5.068 3	5.041 3	3B	5.104 4	5.134 4	5.212 6	5.224 4	0.011 8	5.375 0
5/8 — 6	UN	2A	0.003 2	5.371 8	5.353 6	5.263 5	5.252 9	0.010 6	5.167 3	5.144 7	2B	5.194 6	5.225 2	5.266 7	5.280 5	0.013 8	5.375 0
		3A	0.000 0	5.375 0	5.356 8	5.266 7	5.258 7	0.008 0	5.170 5	5.150 5	3B	5.194 6	5.214 6	5.266 7	5.277 1	0.010 4	5.375 0
5/8 — 8	UN	2A	0.003 0	5.372 0	5.357 0	5.290 8	5.280 9	0.009 9	5.218 6	5.199 7	2B	5.239 7	5.264 7	5.293 8	5.306 6	0.012 8	5.375 0
		3A	0.000 0	5.375 0	5.360 0	5.293 8	5.286 4	0.007 4	5.221 6	5.205 2	3B	5.239 7	5.254 7	5.293 8	5.303 4	0.009 6	5.375 0
5/8 — 12	UN	2A	0.002 0	5.373 0	5.361 6	5.318 9	5.312 2	0.006 7	5.270 8	5.258 1	2B	5.284 8	5.302 9	5.320 9	5.329 6	0.008 7	5.375 0
		3A	0.000 0	5.375 0	5.363 6	5.320 9	5.315 9	0.005 0	5.272 8	5.261 8	3B	5.284 8	5.294 8	5.320 9	5.327 5	0.006 6	5.375 0
5/8 — 16	UN	2A	0.001 8	5.373 2	5.363 8	5.332 6	5.326 5	0.006 1	5.296 5	5.285 9	2B	5.307 3	5.321 4	5.334 4	5.342 3	0.007 9	5.375 0
		3A	0.000 0	5.375 0	5.365 6	5.334 4	5.329 9	0.004 5	5.298 3	5.289 3	3B	5.307 3	5.315 8	5.334 4	5.340 3	0.005 9	5.375 0
5/2 — 4	UN	2A	0.003 6	5.496 4	5.472 6	5.334 0	5.321 9	0.012 1	5.189 7	5.159 6	2B	5.229 4	5.266 9	5.337 6	5.353 4	0.015 8	5.500 0
		3A	0.000 0	5.500 0	5.476 2	5.337 6	5.328 5	0.009 1	5.193 3	5.166 2	3B	5.229 4	5.259 4	5.337 6	5.349 4	0.011 8	5.500 0

Table 2 Unified screw threads, standard series – Limits of size (continued)

1	2	3	4	5	6	7	8	9	10	11	12	13	14	15	16	17	18
Nominal size and threads per inch	Series designation	External threads									Internal threads						
		Class	Allowance	Major diameter		Effective diameter			Minor diameter		Class	Minor diameter		Effective diameter			Major diameter
				Max.	Min.	Max.	Min.	Tol.	Max.	Min.		Min.	Max.	Min.	Max.	Tol.	
				in	in	in	in	in	in	in		in	in	in	in	in	
5½ — 6	UN	2A	0.003 2	5.496 8	5.478 6	5.388 5	5.377 8	0.010 7	5.292 3	5.269 6	2B	5.319 6	5.350 2	5.391 7	5.405 6	0.013 9	5.500 0
		3A	0.000 0	5.500 0	5.481 8	5.391 7	5.383 7	0.008 0	5.295 5	5.275 5	3B	5.319 6	5.339 6	5.391 7	5.402 1	0.010 4	5.500 0
5½ — 8	UN	2A	0.003 0	5.497 0	5.482 0	5.415 8	5.405 9	0.009 9	5.343 6	5.324 7	2B	5.364 7	5.389 7	5.418 8	5.431 7	0.012 9	5.500 0
		3A	0.000 0	5.500 0	5.485 0	5.418 8	5.411 4	0.007 4	5.346 6	5.330 2	3B	5.364 7	5.379 7	5.418 8	5.428 5	0.009 7	5.500 0
5½ — 12	UN	2A	0.002 0	5.498 0	5.486 6	5.443 9	5.437 2	0.006 7	5.395 8	5.383 1	2B	5.409 8	5.427 9	5.445 9	5.454 6	0.008 7	5.500 0
		3A	0.000 0	5.500 0	5.488 6	5.445 9	5.440 9	0.005 0	5.397 8	5.386 8	3B	5.409 8	5.419 8	5.445 9	5.452 5	0.006 6	5.500 0
5½ — 16	UN	2A	0.001 8	5.498 2	5.488 8	5.457 6	5.451 5	0.006 1	5.421 5	5.410 9	2B	5.432 3	5.446 4	5.459 4	5.467 3	0.007 9	5.500 0
		3A	0.000 0	5.500 0	5.490 6	5.459 4	5.454 9	0.004 5	5.423 3	5.414 3	3B	5.432 3	5.440 8	5.459 4	5.465 3	0.005 9	5.500 0
5⅝ — 4	UN	2A	0.003 7	5.621 3	5.597 5	5.458 9	5.446 7	0.012 2	5.314 6	5.284 4	2B	5.354 4	5.391 9	5.462 6	5.478 4	0.015 8	5.625 0
		3A	0.000 0	5.625 0	5.601 2	5.462 6	5.453 5	0.009 1	5.318 3	5.291 2	3B	5.354 4	5.384 4	5.462 6	5.474 5	0.011 9	5.625 0
5⅝ — 6	UN	2A	0.003 2	5.621 8	5.603 6	5.513 5	5.502 7	0.010 8	5.417 3	5.394 5	2B	5.444 6	5.475 2	5.516 7	5.530 7	0.014 0	5.625 0
		3A	0.000 0	5.625 0	5.606 8	5.516 7	5.508 6	0.008 1	5.420 5	5.400 4	3B	5.444 6	5.464 6	5.516 7	5.527 2	0.010 5	5.625 0
5⅝ — 8	UN	2A	0.003 0	5.622 0	5.607 0	5.540 8	5.530 8	0.010 0	5.468 6	5.449 6	2B	5.489 7	5.514 7	5.543 8	5.556 8	0.013 0	5.625 0
		3A	0.000 0	5.625 0	5.610 0	5.543 8	5.536 3	0.007 5	5.471 6	5.455 1	3B	5.489 7	5.504 7	5.543 8	5.553 5	0.009 7	5.625 0
5⅝ — 12	UN	2A	0.002 1	5.622 9	5.611 5	5.568 8	5.561 9	0.006 9	5.520 7	5.507 8	23	5.534 8	5.552 9	5.570 9	5.579 9	0.009 0	5.625 0
		3A	0.000 0	5.625 0	5.613 6	5.570 9	5.565 7	0.005 2	5.522 8	5.511 6	3B	5.534 8	5.544 8	5.570 9	5.577 6	0.006 7	5.625 0
5⅝ — 16	UN	2A	0.001 9	5.623 1	5.613 7	5.582 5	5.576 3	0.006 2	5.546 4	5.535 7	23	5.557 3	5.571 4	5.584 4	5.592 5	0.008 1	5.625 0
		3A	0.000 0	5.625 0	5.615 6	5.584 4	5.579 7	0.004 7	5.548 3	5.539 1	3B	5.557 3	5.565 8	5.584 4	5.590 5	0.006 1	5.625 0
5¾ — 4	UN	2A	0.003 7	5.746 3	5.722 5	5.583 9	5.571 7	0.012 2	5.439 6	5.409 4	2B	5.479 4	5.516 9	5.587 6	5.603 5	0.015 9	5.750 0
		3A	0.000 0	5.750 0	5.726 2	5.587 6	5.578 4	0.009 2	5.443 3	5.416 1	3B	5.479 4	5.509 4	5.587 6	5.599 5	0.011 9	5.750 0
5¾ — 6	UN	2A	0.003 2	5.746 8	5.728 6	5.638 5	5.627 7	0.010 8	5.542 3	5.519 5	2B	5.569 6	5.600 2	5.641 7	5.655 8	0.014 1	5.750 0
		3A	0.000 0	5.750 0	5.731 8	5.641 7	5.633 6	0.008 1	5.545 5	5.525 4	3B	5.569 6	5.589 6	5.641 7	5.652 3	0.010 6	5.750 0
5¾ — 8	UN	2A	0.003 0	5.747 0	5.732 0	5.665 8	5.655 8	0.010 0	5.593 6	5.574 6	2B	5.614 7	5.639 7	5.668 8	5.681 8	0.013 0	5.750 0
		3A	0.000 0	5.750 0	5.735 0	5.668 8	5.661 3	0.007 5	5.596 6	5.580 1	3B	5.614 7	5.629 7	5.668 8	5.678 6	0.009 8	5.750 0
5¾ — 12	UN	2A	0.002 1	5.747 9	5.736 5	5.693 8	5.686 9	0.006 9	5.645 7	5.632 8	2B	5.659 8	5.677 9	5.695 9	5.704 9	0.009 0	5.750 0
		3A	0.000 0	5.750 0	5.738 6	5.695 9	5.690 7	0.005 2	5.647 8	5.636 6	3B	5.659 8	5.669 8	5.695 9	5.702 6	0.006 7	5.750 0

Table 2 Unified screw threads, standard series – Limits of size (continued)

1	2	3	4	5	6	7	8	9	10	11	12	13	14	15	16	17	18
Nominal size and threads per inch	Series designation	External threads									Internal threads						
		Class	Allowance	Major diameter		Effective diameter			Minor diameter		Class	Minor diameter		Effective diameter			Major diameter
				Max.	Min.	Max.	Min.	Tol.	Max.	Min.		Min.	Max.	Min.	Max.	Tol.	Min.
				in	in	in	in	in	in	in		in	in	in	in	in	in
5 $\frac{3}{4}$ – 16	UN	2A	0.001 9	5.748 1	5.738 7	5.707 5	5.701 3	0.006 2	5.671 4	5.660 7	2B	5.682 3	5.696 4	5.709 4	5.717 5	0.008 1	5.750 0
		3A	0.000 0	5.750 0	5.740 6	5.709 4	5.704 7	0.004 7	5.673 3	5.664 1	3B	5.682 3	5.690 8	5.709 4	5.715 5	0.006 1	5.750 0
5 $\frac{7}{8}$ – 4	UN	2A	0.003 7	5.871 3	5.847 5	5.708 9	5.696 6	0.012 3	5.564 6	5.534 3	2B	5.604 4	5.641 9	5.712 6	5.728 6	0.016 0	5.875 0
		3A	0.000 0	5.875 0	5.851 2	5.712 6	5.703 4	0.009 2	5.568 3	5.541 1	3B	5.604 4	5.634 4	5.712 6	5.724 6	0.012 0	5.875 0
5 $\frac{7}{8}$ – 6	UN	2A	0.003 3	5.871 7	5.853 5	5.763 4	5.752 5	0.010 9	5.667 2	5.644 3	2B	5.694 6	5.725 2	5.766 7	5.780 9	0.014 2	5.875 0
		3A	0.000 0	5.875 0	5.856 8	5.766 7	5.758 5	0.008 2	5.670 5	5.650 3	3B	5.694 6	5.714 6	5.766 7	5.777 3	0.010 6	5.875 0
5 $\frac{7}{8}$ – 8	UN	2A	0.003 0	5.872 0	5.857 0	5.790 8	5.780 7	0.010 1	5.718 6	5.699 5	2B	5.739 7	5.764 7	5.793 8	5.806 9	0.013 1	5.875 0
		3A	0.000 0	5.875 0	5.860 0	5.793 8	5.786 2	0.007 6	5.721 6	5.705 0	3B	5.739 7	5.754 7	5.793 8	5.803 6	0.009 8	5.875 0
5 $\frac{7}{8}$ – 12	UN	2A	0.002 1	5.872 9	5.861 5	5.818 8	5.811 9	0.006 9	5.770 7	5.757 8	2B	5.784 8	5.802 9	5.820 9	5.829 9	0.009 0	5.875 0
		3A	0.000 0	5.875 0	5.863 6	5.820 9	5.815 7	0.005 2	5.772 8	5.761 6	3B	5.784 8	5.794 8	5.820 9	5.827 6	0.006 7	5.875 0
5 $\frac{7}{8}$ – 16	UN	2A	0.001 9	5.873 1	5.863 7	5.832 5	5.826 3	0.006 2	5.796 4	5.785 7	2B	5.807 3	5.821 4	5.834 4	5.842 5	0.008 1	5.875 0
		3A	0.000 0	5.875 0	5.865 6	5.834 4	5.829 7	0.004 7	5.798 3	5.789 1	3B	5.807 3	5.815 8	5.834 4	5.840 5	0.006 1	5.875 0
6 – 4	UN	2A	0.003 7	5.996 3	5.972 5	5.833 9	5.821 5	0.012 4	5.689 6	5.659 2	2B	5.729 4	5.766 9	5.837 6	5.853 7	0.016 1	6.000 0
		3A	0.000 0	6.000 0	5.976 2	5.837 6	5.828 3	0.009 3	5.693 3	5.666 0	3B	5.729 4	5.759 4	5.837 6	5.849 6	0.012 0	6.000 0
6 – 6	UN	2A	0.003 3	5.996 7	5.978 5	5.888 4	5.877 5	0.010 9	5.792 2	5.769 3	2B	5.819 6	5.850 2	5.891 7	5.905 9	0.014 2	6.000 0
		3A	0.000 0	6.000 0	5.981 8	5.891 7	5.883 5	0.008 2	5.795 5	5.775 3	3B	5.819 6	5.839 6	5.891 7	5.902 4	0.010 7	6.000 0
6 – 8	UN	2A	0.003 0	5.997 0	5.982 0	5.915 8	5.905 7	0.010 1	5.843 6	5.824 5	2B	5.864 7	5.889 7	5.918 8	5.932 0	0.013 2	6.000 0
		3A	0.000 0	6.000 0	5.985 0	5.918 8	5.911 2	0.007 6	5.846 6	5.830 0	3B	5.864 7	5.879 7	5.918 8	5.928 7	0.009 9	6.000 0
6 – 12	UN	2A	0.002 1	6.997 9	5.986 5	5.943 8	5.936 9	0.006 9	5.895 7	5.882 8	2B	5.909 8	5.927 9	5.945 9	5.954 9	0.009 0	6.000 0
		3A	0.000 0	6.000 0	5.988 6	5.945 9	5.940 7	0.005 2	5.897 8	5.886 6	3B	5.909 8	5.919 8	5.945 9	5.952 6	0.006 7	6.000 0
6 – 16	UN	2A	0.001 9	5.998 1	5.988 7	5.957 5	5.951 3	0.006 2	5.921 4	5.910 7	2B	5.932 3	5.946 4	5.959 4	5.967 5	0.008 1	6.000 0
		3A	0.000 0	6.000 0	5.990 6	5.959 4	5.954 7	0.004 7	5.923 3	5.914 1	3B	5.932 3	5.940 8	5.959 4	5.965 5	0.006 1	6.000 0

Table 3 Coarse thread series (UNC) – Limits and tolerances for finished uncoated threads – External threads Class 1A

1	2	3	4	5	6	7	8	9	10	
Designation	Major diameter			Effective diameter			Minor diameter			
	Max.	Min.	Tol.	Max.	Min.	Tol.	Max.	Min.	Tol.	
	in	in	in	in	in	in	in	in	in	
$\frac{1}{4}$ — 20	UNC — 1A	0.248 9	0.236 7	0.012 2	0.216 4	0.210 8	0.005 6	0.187 6	0.178 4	0.009 2
$\frac{5}{16}$ — 18	UNC — 1A	0.311 3	0.298 2	0.013 1	0.275 2	0.269 1	0.006 1	0.243 1	0.233 0	0.010 1
$\frac{3}{8}$ — 16	UNC — 1A	0.373 7	0.359 5	0.014 2	0.333 1	0.326 6	0.006 5	0.297 0	0.286 0	0.011 0
$\frac{7}{16}$ — 14	UNC — 1A	0.436 1	0.420 6	0.015 5	0.389 7	0.382 6	0.007 1	0.348 5	0.336 3	0.012 2
$\frac{1}{2}$ — 13	UNC — 1A	0.498 5	0.482 2	0.016 3	0.448 5	0.441 1	0.007 4	0.404 1	0.391 1	0.013 0
$\frac{9}{16}$ — 12	UNC — 1A	0.560 9	0.543 7	0.017 2	0.506 8	0.499 0	0.007 8	0.458 7	0.444 9	0.013 8
$\frac{5}{8}$ — 11	UNC — 1A	0.623 4	0.605 2	0.018 2	0.564 4	0.556 1	0.008 3	0.511 9	0.497 1	0.014 8
$\frac{3}{4}$ — 10	UNC — 1A	0.748 2	0.728 8	0.019 4	0.683 2	0.674 4	0.008 8	0.625 5	0.609 5	0.016 0
$\frac{7}{8}$ — 9	UNC — 1A	0.873 1	0.852 3	0.020 8	0.800 9	0.791 4	0.009 5	0.736 8	0.719 3	0.017 5
1 — 8	UNC — 1A	0.998 0	0.975 5	0.022 5	0.916 8	0.906 7	0.010 1	0.844 6	0.825 5	0.019 1
$1\frac{1}{8}$ — 7	UNC — 1A	1.122 8	1.098 2	0.024 6	1.030 0	1.019 1	0.010 9	0.947 5	0.926 3	0.021 2
$1\frac{1}{4}$ — 7	UNC — 1A	1.247 8	1.223 2	0.024 6	1.155 0	1.143 9	0.011 1	1.072 5	1.051 1	0.021 4
$1\frac{3}{8}$ — 6	UNC — 1A	1.372 6	1.345 3	0.027 3	1.264 3	1.252 3	0.012 0	1.168 1	1.144 1	0.024 0
$1\frac{1}{2}$ — 6	UNC — 1A	1.497 6	1.470 3	0.027 3	1.389 3	1.377 2	0.012 1	1.293 1	1.269 0	0.024 1
$1\frac{3}{4}$ — 5	UNC — 1A	1.747 3	1.716 5	0.030 8	1.617 4	1.604 0	0.013 4	1.501 9	1.474 1	0.027 8
2 — $4\frac{1}{2}$	UNC — 1A	1.997 1	1.964 1	0.033 0	1.852 8	1.838 5	0.014 3	1.724 5	1.694 2	0.030 3
$2\frac{1}{4}$ — $4\frac{1}{2}$	UNC — 1A	2.247 1	2.214 1	0.033 0	2.102 8	2.088 2	0.014 6	1.974 5	1.943 9	0.030 6
$2\frac{1}{2}$ — 4	UNC — 1A	2.496 9	2.461 2	0.035 7	2.334 5	2.319 0	0.015 5	2.190 2	2.156 7	0.033 5
$2\frac{3}{4}$ — 4	UNC — 1A	2.746 8	2.711 1	0.035 7	2.584 4	2.568 6	0.015 8	2.440 1	2.406 3	0.033 8
3 — 4	UNC — 1A	2.996 8	2.961 1	0.035 7	2.834 4	2.818 3	0.016 1	2.690 1	2.656 0	0.034 1
$3\frac{1}{4}$ — 4	UNC — 1A	3.246 7	3.211 0	0.035 7	3.084 3	3.068 0	0.016 3	2.940 0	2.905 7	0.034 3
$3\frac{1}{2}$ — 4	UNC — 1A	3.496 7	3.461 0	0.035 7	3.334 3	3.317 7	0.016 6	3.190 0	3.155 4	0.034 6
$3\frac{3}{4}$ — 4	UNC — 1A	3.746 6	3.710 9	0.035 7	3.584 2	3.567 4	0.016 8	3.439 9	3.405 1	0.034 8
4 — 4	UNC — 1A	3.996 6	3.960 9	0.035 7	3.834 2	3.817 2	0.017 0	3.689 9	3.654 9	0.035 0

Table 4 Coarse thread series (UNC) – Limits and tolerances for finished uncoated threads – Internal threads Class 1B

1	2	3	4	5	6	7	8
Designation	Minor diameter			Effective diameter			Major diameter
	Min. in	Max. in	Tol. in	Min. in	Max. in	Tol. in	Min. in
$\frac{1}{4}$ — 20 UNC — 1B	0.195 9	0.207 4	0.011 5	0.217 5	0.224 8	0.007 3	0.250 0
$\frac{5}{16}$ — 18 UNC — 1B	0.252 4	0.265 1	0.012 7	0.276 4	0.284 3	0.007 9	0.312 5
$\frac{3}{8}$ — 16 UNC — 1B	0.307 3	0.321 4	0.014 1	0.334 4	0.342 9	0.008 5	0.375 0
$\frac{7}{16}$ — 14 UNC — 1B	0.360 2	0.376 0	0.015 8	0.391 1	0.400 3	0.009 2	0.437 5
$\frac{1}{2}$ — 13 UNC — 1B	0.416 7	0.433 6	0.016 9	0.450 0	0.459 7	0.009 7	0.500 0
$\frac{9}{16}$ — 12 UNC — 1B	0.472 3	0.490 4	0.018 1	0.508 4	0.518 6	0.010 2	0.562 5
$\frac{5}{8}$ — 11 UNC — 1B	0.526 6	0.546 0	0.019 4	0.566 0	0.576 7	0.010 7	0.625 0
$\frac{3}{4}$ — 10 UNC — 1B	0.641 7	0.662 7	0.021 0	0.685 0	0.696 5	0.011 5	0.750 0
$\frac{7}{8}$ — 9 UNC — 1B	0.754 7	0.777 5	0.022 8	0.802 8	0.815 1	0.012 3	0.875 0
1 — 8 UNC — 1B	0.864 7	0.889 7	0.025 0	0.918 8	0.932 0	0.013 2	1.000 0
$1\frac{1}{8}$ — 7 UNC — 1B	0.970 4	0.998 0	0.027 6	1.032 2	1.046 3	0.014 1	1.125 0
$1\frac{1}{4}$ — 7 UNC — 1B	1.095 4	1.123 0	0.027 6	1.157 2	1.171 6	0.014 4	1.250 0
$1\frac{3}{8}$ — 6 UNC — 1B	1.194 6	1.225 2	0.030 6	1.266 7	1.282 2	0.015 5	1.375 0
$1\frac{1}{2}$ — 6 UNC — 1B	1.319 6	1.350 2	0.030 6	1.391 7	1.407 5	0.015 8	1.500 0
$1\frac{3}{4}$ — 5 UNC — 1B	1.533 5	1.567 5	0.034 0	1.620 1	1.637 5	0.017 4	1.750 0
2 — 4 $\frac{1}{2}$ UNC — 1B	1.759 4	1.795 2	0.035 8	1.855 7	1.874 3	0.018 6	2.000 0
2 $\frac{1}{4}$ — 4 $\frac{1}{2}$ UNC — 1B	2.009 4	2.045 2	0.035 8	2.105 7	2.124 7	0.019 0	2.250 0
2 $\frac{1}{2}$ — 4 UNC — 1B	2.229 4	2.266 9	0.037 5	2.337 6	2.357 8	0.020 2	2.500 0
2 $\frac{3}{4}$ — 4 UNC — 1B	2.479 4	2.516 9	0.037 5	2.587 6	2.608 2	0.020 6	2.750 0
3 — 4 UNC — 1B	2.729 4	2.766 9	0.037 5	2.837 6	2.858 5	0.020 9	3.000 0
3 $\frac{1}{4}$ — 4 UNC — 1B	2.979 4	3.016 9	0.037 5	3.087 6	3.108 8	0.021 2	3.250 0
3 $\frac{1}{2}$ — 4 UNC — 1B	3.229 4	3.266 9	0.037 5	3.337 6	3.359 1	0.021 5	3.500 0
3 $\frac{3}{4}$ — 4 UNC — 1B	3.479 4	3.516 9	0.037 5	3.587 6	3.609 4	0.021 8	3.750 0
4 — 4 UNC — 1B	3.729 4	3.766 9	0.037 5	3.837 6	3.859 7	0.022 1	4.000 0

Table 5 Coarse thread series (UNC) – Limits and tolerances for finished uncoated threads – External threads Class 2A

1	2	3	4	5	6	7	8	9	10	
Designation	Major diameter			Effective diameter			Minor diameter			
	Max.	Min.	Tol.	Max.	Min.	Tol.	Max.	Min.	Tol.	
	in	in	in	in	in	in	in	in	in	
$\frac{1}{4}$ — 20	UNC — 2A	0.248 9	0.240 8	0.008 1	0.216 4	0.212 7	0.003 7	0.187 6	0.180 3	0.007 3
$\frac{5}{16}$ — 18	UNC — 2A	0.311 3	0.302 6	0.008 7	0.275 2	0.271 2	0.004 0	0.243 1	0.235 1	0.008 0
$\frac{3}{8}$ — 16	UNC — 2A	0.373 7	0.364 3	0.009 4	0.333 1	0.328 7	0.004 4	0.297 0	0.288 1	0.008 9
$\frac{7}{16}$ — 14	UNC — 2A	0.436 1	0.425 8	0.010 3	0.389 7	0.385 0	0.004 7	0.348 5	0.338 7	0.009 8
$\frac{1}{2}$ — 13	UNC — 2A	0.498 5	0.487 6	0.010 9	0.448 5	0.443 5	0.005 0	0.404 1	0.393 6	0.010 5
$\frac{9}{16}$ — 12	UNC — 2A	0.560 9	0.549 5	0.011 4	0.506 8	0.501 6	0.005 2	0.458 7	0.447 5	0.011 2
$\frac{5}{8}$ — 11	UNC — 2A	0.623 4	0.611 3	0.012 1	0.564 4	0.558 9	0.005 5	0.511 9	0.499 9	0.012 0
$\frac{3}{4}$ — 10	UNC — 2A	0.748 2	0.735 3	0.012 9	0.683 2	0.677 3	0.005 9	0.625 5	0.612 4	0.013 1
$\frac{7}{8}$ — 9	UNC — 2A	0.873 1	0.859 2	0.013 9	0.800 9	0.794 6	0.006 3	0.736 8	0.722 5	0.014 3
1 — 8	UNC — 2A	0.998 0	0.983 0	0.015 0	0.916 8	0.910 0	0.006 8	0.844 6	0.828 8	0.015 8
$1\frac{1}{8}$ — 7	UNC — 2A	1.122 8	1.106 4	0.016 4	1.030 0	1.022 8	0.007 2	0.947 5	0.930 0	0.017 5
$1\frac{1}{4}$ — 7	UNC — 2A	1.247 8	1.231 4	0.016 4	1.155 0	1.147 6	0.007 4	1.072 5	1.054 8	0.017 7
$1\frac{3}{8}$ — 6	UNC — 2A	1.372 6	1.354 4	0.018 2	1.264 3	1.256 3	0.008 0	1.168 1	1.148 1	0.020 0
$1\frac{1}{2}$ — 6	UNC — 2A	1.497 6	1.479 4	0.018 2	1.389 3	1.381 2	0.008 1	1.293 1	1.273 0	0.020 1
$1\frac{3}{4}$ — 5	UNC — 2A	1.747 3	1.726 8	0.020 5	1.617 4	1.608 5	0.008 9	1.501 9	1.478 6	0.023 3
2 — $4\frac{1}{2}$	UNC — 2A	1.997 1	1.975 1	0.022 0	1.852 8	1.843 3	0.009 5	1.724 5	1.699 0	0.025 5
$2\frac{1}{4}$ — $4\frac{1}{2}$	UNC — 2A	2.247 1	2.225 1	0.022 0	2.102 8	2.093 1	0.009 7	1.974 5	1.948 8	0.025 7
$2\frac{1}{2}$ — 4	UNC — 2A	2.496 9	2.473 1	0.023 8	2.334 5	2.324 1	0.010 4	2.190 2	2.161 8	0.028 4
$2\frac{3}{4}$ — 4	UNC — 2A	2.746 8	2.723 0	0.023 8	2.584 4	2.573 9	0.010 5	2.440 1	2.411 6	0.028 5
3 — 4	UNC — 2A	2.996 8	2.973 0	0.023 8	2.834 4	2.823 7	0.010 7	2.690 1	2.661 4	0.028 7
$3\frac{1}{4}$ — 4	UNC — 2A	3.246 7	3.222 9	0.023 8	3.084 3	3.073 4	0.010 9	2.940 0	2.911 1	0.028 9
$3\frac{1}{2}$ — 4	UNC — 2A	3.496 7	3.472 9	0.023 8	3.334 3	3.323 3	0.011 0	3.190 0	3.161 0	0.029 0
$3\frac{3}{4}$ — 4	UNC — 2A	3.746 6	3.722 8	0.023 8	3.584 2	3.573 0	0.011 2	3.439 9	3.410 7	0.029 2
4 — 4	UNC — 2A	3.996 6	3.972 8	0.023 8	3.834 2	3.822 9	0.011 3	3.689 9	3.660 6	0.029 3

Table 6 Coarse thread series (UNC) – Limits and tolerances for finished uncoated threads – Internal threads Class 2B

1	2	3	4	5	6	7	8
Designation	Minor diameter			Effective diameter			Major diameter
	Min. in	Max. in	Tol. in	Min. in	Max. in	Tol. in	Min. in
$\frac{1}{4}$ — 20 UNC — 2B	0.195 9	0.207 4	0.011 5	0.217 5	0.222 3	0.004 8	0.250 0
$\frac{5}{16}$ — 18 UNC — 2B	0.252 4	0.265 1	0.012 7	0.276 4	0.281 7	0.005 3	0.312 5
$\frac{3}{8}$ — 16 UNC — 2B	0.307 3	0.321 4	0.014 1	0.334 4	0.340 1	0.005 7	0.375 0
$\frac{7}{16}$ — 14 UNC — 2B	0.360 2	0.376 0	0.015 8	0.391 1	0.397 2	0.006 1	0.437 5
$\frac{1}{2}$ — 13 UNC — 2B	0.416 7	0.433 6	0.016 9	0.450 0	0.456 5	0.006 5	0.500 0
$\frac{9}{16}$ — 12 UNC — 2B	0.472 3	0.490 4	0.018 1	0.508 4	0.515 2	0.006 8	0.562 5
$\frac{5}{8}$ — 11 UNC — 2B	0.526 6	0.546 0	0.019 4	0.566 0	0.573 2	0.007 2	0.625 0
$\frac{3}{4}$ — 10 UNC — 2B	0.641 7	0.662 7	0.021 0	0.685 0	0.692 7	0.007 7	0.750 0
$\frac{7}{8}$ — 9 UNC — 2B	0.754 7	0.777 5	0.022 8	0.802 8	0.811 0	0.008 2	0.875 0
1 — 8 UNC — 2B	0.864 7	0.889 7	0.025 0	0.918 8	0.927 6	0.008 8	1.000 0
$1\frac{1}{8}$ — 7 UNC — 2B	0.970 4	0.998 0	0.027 6	1.032 2	1.041 6	0.009 4	1.125 0
$1\frac{1}{4}$ — 7 UNC — 2B	1.095 4	1.123 0	0.027 6	1.157 2	1.166 8	0.009 6	1.250 0
$1\frac{3}{8}$ — 6 UNC — 2B	1.194 6	1.225 2	0.030 6	1.266 7	1.277 1	0.010 4	1.375 0
$1\frac{1}{2}$ — 6 UNC — 2B	1.319 6	1.350 2	0.030 6	1.391 7	1.402 2	0.010 5	1.500 0
$1\frac{3}{4}$ — 5 UNC — 2B	1.533 5	1.567 5	0.034 0	1.620 1	1.631 7	0.011 6	1.750 0
2 — 4 $\frac{1}{2}$ UNC — 2B	1.759 4	1.795 2	0.035 8	1.855 7	1.868 1	0.012 4	2.000 0
2 $\frac{1}{4}$ — 4 $\frac{1}{2}$ UNC — 2B	2.009 4	2.045 2	0.035 8	2.105 7	2.118 3	0.012 6	2.250 0
2 $\frac{1}{2}$ — 4 UNC — 2B	2.229 4	2.266 9	0.037 5	2.337 6	2.351 1	0.013 5	2.500 0
2 $\frac{3}{4}$ — 4 UNC — 2B	2.479 4	2.516 9	0.037 5	2.587 6	2.601 3	0.013 7	2.750 0
3 — 4 UNC — 2B	2.729 4	2.766 9	0.037 5	2.837 6	2.851 5	0.013 9	3.000 0
3 $\frac{1}{4}$ — 4 UNC — 2B	2.979 4	3.016 9	0.037 5	3.087 6	3.101 7	0.014 1	3.250 0
3 $\frac{1}{2}$ — 4 UNC — 2B	3.229 4	3.266 9	0.037 5	3.337 6	3.351 9	0.014 3	3.500 0
3 $\frac{3}{4}$ — 4 UNC — 2B	3.479 4	3.516 9	0.037 5	3.587 6	3.602 1	0.014 5	3.750 0
4 — 4 UNC — 2B	3.729 4	3.766 9	0.037 5	3.837 6	3.852 3	0.014 7	4.000 0

Table 7 Coarse thread series (UNC) – Limits and tolerances for finished uncoated threads – External threads Class 3A

1	2	3	4	5	6	7	8	9	10
Designation	Major diameter			Effective diameter			Minor diameter		
	Max.	Min.	Tol.	Max.	Min.	Tol.	Max.	Min.	Tol.
	in	in	in	in	in	in	in	in	in
$\frac{1}{4}$ — 20 UNC — 3A	0.250 0	0.241 9	0.008 1	0.217 5	0.214 7	0.002 8	0.188 7	0.182 3	0.006 4
$\frac{5}{16}$ — 18 UNC — 3A	0.312 5	0.303 8	0.008 7	0.276 4	0.273 4	0.003 0	0.244 3	0.237 3	0.007 0
$\frac{3}{8}$ — 16 UNC — 3A	0.375 0	0.365 6	0.009 4	0.334 4	0.331 1	0.003 3	0.298 3	0.290 5	0.007 8
$\frac{7}{16}$ — 14 UNC — 3A	0.437 5	0.427 2	0.010 3	0.391 1	0.387 6	0.003 5	0.349 9	0.341 3	0.008 6
$\frac{1}{2}$ — 13 UNC — 3A	0.500 0	0.489 1	0.010 9	0.450 0	0.446 3	0.003 7	0.405 6	0.396 3	0.009 3
$\frac{9}{16}$ — 12 UNC — 3A	0.562 5	0.551 1	0.011 4	0.508 4	0.504 5	0.003 9	0.460 3	0.450 4	0.009 9
$\frac{5}{8}$ — 11 UNC — 3A	0.625 0	0.612 9	0.012 1	0.566 0	0.561 9	0.004 1	0.513 5	0.502 9	0.010 6
$\frac{3}{4}$ — 10 UNC — 3A	0.750 0	0.737 1	0.012 9	0.685 0	0.680 6	0.004 4	0.627 3	0.615 7	0.011 6
$\frac{7}{8}$ — 9 UNC — 3A	0.875 0	0.861 1	0.013 9	0.802 8	0.798 1	0.004 7	0.738 7	0.726 0	0.012 7
1 — 8 UNC — 3A	1.000 0	0.985 0	0.015 0	0.918 8	0.913 7	0.005 1	0.846 6	0.832 5	0.014 1
$1\frac{1}{8}$ — 7 UNC — 3A	1.125 0	1.108 6	0.016 4	1.032 2	1.026 8	0.005 4	0.949 7	0.934 0	0.015 7
$1\frac{1}{4}$ — 7 UNC — 3A	1.250 0	1.233 6	0.016 4	1.157 2	1.151 7	0.005 5	1.074 7	1.058 9	0.015 8
$1\frac{3}{8}$ — 6 UNC — 3A	1.375 0	1.356 8	0.018 2	1.266 7	1.260 7	0.006 0	1.170 5	1.152 5	0.018 0
$1\frac{1}{2}$ — 6 UNC — 3A	1.500 0	1.481 8	0.018 2	1.391 7	1.385 6	0.006 1	1.295 5	1.277 4	0.018 1
$1\frac{3}{4}$ — 5 UNC — 3A	1.750 0	1.729 5	0.020 5	1.620 1	1.613 4	0.006 7	1.504 6	1.483 5	0.021 1
2 — $4\frac{1}{2}$ UNC — 3A	2.000 0	1.978 0	0.022 0	1.855 7	1.848 6	0.007 1	1.727 4	1.704 3	0.023 1
$2\frac{1}{4}$ — $4\frac{1}{2}$ UNC — 3A	2.250 0	2.228 0	0.022 0	2.105 7	2.098 4	0.007 3	1.977 4	1.954 1	0.023 3
$2\frac{1}{2}$ — 4 UNC — 3A	2.500 0	2.476 2	0.023 8	2.337 6	2.329 8	0.007 8	2.193 3	2.167 5	0.025 8
$2\frac{3}{4}$ — 4 UNC — 3A	2.750 0	2.726 2	0.023 8	2.587 6	2.579 7	0.007 9	2.443 3	2.417 4	0.025 9
3 — 4 UNC — 3A	3.000 0	2.976 2	0.023 8	2.837 6	2.829 6	0.008 0	2.693 3	2.667 3	0.026 0
$3\frac{1}{4}$ — 4 UNC — 3A	3.250 0	3.226 2	0.023 8	3.087 6	3.079 4	0.008 2	2.943 3	2.917 1	0.026 2
$3\frac{1}{2}$ — 4 UNC — 3A	3.500 0	3.476 2	0.023 8	3.337 6	3.329 3	0.008 3	3.193 3	3.167 0	0.026 3
$3\frac{3}{4}$ — 4 UNC — 3A	3.750 0	3.726 2	0.023 8	3.587 6	3.579 2	0.008 4	3.443 3	3.416 9	0.026 4
4 — 4 UNC — 3A	4.000 0	3.976 2	0.023 8	3.837 6	3.829 1	0.008 5	3.693 3	3.666 8	0.026 5

Table 8 Coarse thread series (UNC) – Limits and tolerances for finished uncoated threads – Internal threads Class 3B

1	2	3	4	5	6	7	8
Designation	Minor diameter			Effective diameter			Major diameter
	Min. in	Max. in	Tol. in	Min. in	Max. in	Tol. in	Min. in
$\frac{1}{4}$ — 20 UNC — 3B	0.195 9	0.206 7	0.010 8	0.217 5	0.221 1	0.003 6	0.250 0
$\frac{5}{16}$ — 18 UNC — 3B	0.252 4	0.263 0	0.010 6	0.276 4	0.280 3	0.003 9	0.312 5
$\frac{3}{8}$ — 16 UNC — 3B	0.307 3	0.318 2	0.010 9	0.334 4	0.338 7	0.004 3	0.375 0
$\frac{7}{16}$ — 14 UNC — 3B	0.360 2	0.371 7	0.011 5	0.391 1	0.395 7	0.004 6	0.437 5
$\frac{1}{2}$ — 13 UNC — 3B	0.416 7	0.428 4	0.011 7	0.450 0	0.454 8	0.004 8	0.500 0
$\frac{9}{16}$ — 12 UNC — 3B	0.472 3	0.484 3	0.012 0	0.508 4	0.513 5	0.005 1	0.562 5
$\frac{5}{8}$ — 11 UNC — 3B	0.526 6	0.539 1	0.012 5	0.566 0	0.571 4	0.005 4	0.625 0
$\frac{3}{4}$ — 10 UNC — 3B	0.641 7	0.654 5	0.012 8	0.685 0	0.690 7	0.005 7	0.750 0
$\frac{7}{8}$ — 9 UNC — 3B	0.754 7	0.768 5	0.013 8	0.802 8	0.808 9	0.006 1	0.875 0
1 — 8 UNC — 3B	0.864 7	0.879 7	0.015 0	0.918 8	0.925 4	0.006 6	1.000 0
$1\frac{1}{8}$ — 7 UNC — 3B	0.970 4	0.987 5	0.017 1	1.032 2	1.039 3	0.007 1	1.125 0
$1\frac{1}{4}$ — 7 UNC — 3B	1.095 4	1.112 5	0.017 1	1.157 2	1.164 4	0.007 2	1.250 0
$1\frac{3}{8}$ — 6 UNC — 3B	1.194 6	1.214 6	0.020 0	1.266 7	1.274 5	0.007 8	1.375 0
$1\frac{1}{2}$ — 6 UNC — 3B	1.319 6	1.339 6	0.020 0	1.391 7	1.399 6	0.007 9	1.500 0
$1\frac{3}{4}$ — 5 UNC — 3B	1.533 5	1.557 5	0.024 0	1.620 1	1.628 8	0.008 7	1.750 0
2 — 4 $\frac{1}{2}$ UNC — 3B	1.759 4	1.786 1	0.026 7	1.855 7	1.865 0	0.009 3	2.000 0
2 $\frac{1}{4}$ — 4 $\frac{1}{2}$ UNC — 3B	2.009 4	2.036 1	0.026 7	2.105 7	2.115 2	0.009 5	2.250 0
2 $\frac{1}{2}$ — 4 UNC — 3B	2.229 4	2.259 4	0.030 0	2.337 6	2.347 7	0.010 1	2.500 0
2 $\frac{3}{4}$ — 4 UNC — 3B	2.479 4	2.509 4	0.030 0	2.587 6	2.597 9	0.010 3	2.750 0
3 — 4 UNC — 3B	2.729 4	2.759 4	0.030 0	2.837 6	2.848 0	0.010 4	3.000 0
3 $\frac{1}{4}$ — 4 UNC — 3B	2.979 4	3.009 4	0.030 0	3.087 6	3.098 2	0.010 6	3.250 0
3 $\frac{1}{2}$ — 4 UNC — 3B	3.229 4	3.259 4	0.030 0	3.337 6	3.348 4	0.010 8	3.500 0
3 $\frac{3}{4}$ — 4 UNC — 3B	3.479 4	3.509 4	0.030 0	3.587 6	3.598 5	0.010 9	3.750 0
4 — 4 UNC — 3B	3.729 4	3.759 4	0.030 0	3.837 6	3.848 7	0.011 1	4.000 0

Table 9 Fine thread series (UNF) – Limits and tolerances for finished uncoated threads – External threads Class 1A

1	2	3	4	5	6	7	8	9	10
Designation	Major diameter			Effective diameter			Minor diameter		
	Max. in	Min. in	Tol. in	Max. in	Min. in	Tol. in	Max. in	Min. in	Tol. in
$\frac{1}{4}$ —28 UNF—1A	0.249 0	0.239 2	0.009 8	0.225 8	0.220 8	0.005 0	0.205 2	0.197 6	0.007 6
$\frac{5}{16}$ —24 UNF—1A	0.311 4	0.300 6	0.010 8	0.284 3	0.278 8	0.005 5	0.260 3	0.251 8	0.008 5
$\frac{3}{8}$ —24 UNF—1A	0.373 9	0.363 1	0.010 8	0.346 8	0.341 1	0.005 7	0.322 8	0.314 1	0.008 7
$\frac{7}{16}$ —20 UNF—1A	0.436 2	0.424 0	0.012 2	0.403 7	0.397 5	0.006 2	0.374 9	0.365 1	0.009 8
$\frac{1}{2}$ —20 UNF—1A	0.498 7	0.486 5	0.012 2	0.466 2	0.459 8	0.006 4	0.437 4	0.427 4	0.010 0
$\frac{9}{16}$ —18 UNF—1A	0.561 1	0.548 0	0.013 1	0.525 0	0.518 2	0.006 8	0.492 9	0.482 1	0.010 8
$\frac{5}{8}$ —18 UNF—1A	0.623 6	0.610 5	0.013 1	0.587 5	0.580 5	0.007 0	0.555 4	0.544 4	0.011 0
$\frac{3}{4}$ —16 UNF—1A	0.748 5	0.734 3	0.014 2	0.707 9	0.700 4	0.007 5	0.671 8	0.659 8	0.012 0
$\frac{7}{8}$ —14 UNF—1A	0.873 4	0.857 9	0.015 5	0.827 0	0.818 9	0.008 1	0.785 8	0.772 6	0.013 2
1—12 UNF—1A	0.998 2	0.981 0	0.017 2	0.944 1	0.935 3	0.008 8	0.896 0	0.881 2	0.014 8
$1\frac{1}{8}$ —12 UNF—1A	1.123 2	1.106 0	0.017 2	1.069 1	1.060 1	0.009 0	1.021 0	1.006 0	0.015 0
$1\frac{1}{4}$ —12 UNF—1A	1.248 2	1.231 0	0.017 2	1.194 1	1.184 9	0.009 2	1.146 0	1.130 8	0.015 2
$1\frac{3}{8}$ —12 UNF—1A	1.373 1	1.355 9	0.017 2	1.319 0	1.309 6	0.009 4	1.270 9	1.255 5	0.015 4
$1\frac{1}{2}$ —12 UNF—1A	1.498 1	1.480 9	0.017 2	1.444 0	1.434 4	0.009 6	1.395 9	1.380 3	0.015 6

Table 10 Fine thread series (UNF) – Limits and tolerances for finished uncoated threads – Internal threads Class 1B

1	2	3	4	5	6	7	8
Designation	Minor diameter			Effective diameter			Major diameter
	Min. in	Max. in	Tol. in	Min. in	Max. in	Tol. in	Min. in
$\frac{1}{4}$ —28 UNF—1B	0.211 3	0.219 7	0.008 4	0.226 8	0.233 3	0.006 5	0.250 0
$\frac{5}{16}$ —24 UNF—1B	0.267 4	0.277 1	0.009 7	0.285 4	0.292 5	0.007 1	0.312 5
$\frac{3}{8}$ —24 UNF—1B	0.329 9	0.339 6	0.009 7	0.347 9	0.355 3	0.007 4	0.375 0
$\frac{7}{16}$ —20 UNF—1B	0.383 4	0.394 9	0.011 5	0.405 0	0.413 1	0.008 1	0.437 5
$\frac{1}{2}$ —20 UNF—1B	0.445 9	0.457 4	0.011 5	0.467 5	0.475 9	0.008 4	0.500 0
$\frac{9}{16}$ —18 UNF—1B	0.502 4	0.515 1	0.012 7	0.526 4	0.535 3	0.008 9	0.562 5
$\frac{5}{8}$ —18 UNF—1B	0.564 9	0.577 6	0.012 7	0.588 9	0.598 0	0.009 1	0.625 0
$\frac{3}{4}$ —16 UNF—1B	0.682 3	0.696 4	0.014 1	0.709 4	0.719 2	0.009 8	0.750 0
$\frac{7}{8}$ —14 UNF—1B	0.797 7	0.813 5	0.015 8	0.828 6	0.839 2	0.010 6	0.875 0
1—12 UNF—1B	0.909 8	0.927 9	0.018 1	0.945 9	0.957 3	0.011 4	1.000 0
$1\frac{1}{8}$ —12 UNF—1B	1.034 8	1.052 9	0.018 1	1.070 9	1.082 6	0.011 7	1.125 0
$1\frac{1}{4}$ —12 UNF—1B	1.159 8	1.177 9	0.018 1	1.195 9	1.207 9	0.012 0	1.250 0
$1\frac{3}{8}$ —12 UNF—1B	1.284 8	1.302 9	0.018 1	1.320 9	1.333 2	0.012 3	1.375 0
$1\frac{1}{2}$ —12 UNF—1B	1.409 8	1.427 9	0.018 1	1.445 9	1.458 4	0.012 5	1.500 0

Table 11 Fine thread series (UNF) – Limits and tolerances for finished uncoated threads – External threads Class 2A

1	2	3	4	5	6	7	8	9	10
Designation	Major diameter			Effective diameter			Minor diameter		
	Max. in	Min. in	Tol. in	Max. in	Min. in	Tol. in	Max. in	Min. in	Tol. in
$\frac{1}{4}$ — 28 UNF — 2A	0.249 0	0.242 5	0.006 5	0.225 8	0.222 5	0.003 3	0.205 2	0.199 3	0.005 9
$\frac{5}{16}$ — 24 UNF — 2A	0.311 4	0.304 2	0.007 2	0.284 3	0.280 6	0.003 7	0.260 3	0.253 6	0.006 7
$\frac{3}{8}$ — 24 UNF — 2A	0.373 9	0.366 7	0.007 2	0.346 8	0.343 0	0.003 8	0.322 8	0.316 0	0.006 8
$\frac{7}{16}$ — 20 UNF — 2A	0.436 2	0.428 1	0.008 1	0.403 7	0.399 5	0.004 2	0.374 9	0.367 1	0.007 8
$\frac{1}{2}$ — 20 UNF — 2A	0.498 7	0.490 6	0.008 1	0.466 2	0.461 9	0.004 3	0.437 4	0.429 5	0.007 9
$\frac{9}{16}$ — 18 UNF — 2A	0.561 1	0.552 4	0.008 7	0.525 0	0.520 5	0.004 5	0.492 9	0.484 4	0.008 5
$\frac{5}{8}$ — 18 UNF — 2A	0.623 6	0.614 9	0.008 7	0.587 5	0.582 8	0.004 7	0.555 4	0.546 7	0.008 7
$\frac{3}{4}$ — 16 UNF — 2A	0.748 5	0.739 1	0.009 4	0.707 9	0.702 9	0.005 0	0.671 8	0.662 3	0.009 5
$\frac{7}{8}$ — 14 UNF — 2A	0.873 4	0.863 1	0.010 3	0.827 0	0.821 6	0.005 4	0.785 8	0.775 3	0.010 5
1 — 12 UNF — 2A	0.998 2	0.986 8	0.011 4	0.944 1	0.938 2	0.005 9	0.896 0	0.884 1	0.011 9
$1\frac{1}{8}$ — 12 UNF — 2A	1.123 2	1.111 8	0.011 4	1.069 1	1.063 1	0.006 0	1.021 0	1.009 0	0.012 0
$1\frac{1}{4}$ — 12 UNF — 2A	1.248 2	1.236 8	0.011 4	1.194 1	1.187 9	0.006 2	1.146 0	1.133 8	0.012 2
$1\frac{3}{8}$ — 12 UNF — 2A	1.373 1	1.361 7	0.011 4	1.319 0	1.312 7	0.006 3	1.270 9	1.258 6	0.012 3
$1\frac{1}{2}$ — 12 UNF — 2A	1.498 1	1.486 7	0.011 4	1.444 0	1.437 6	0.006 4	1.395 9	1.383 5	0.012 4

Table 12 Fine thread series (UNF) – Limits and tolerances for finished uncoated threads – Internal threads Class 2B

1	2	3	4	5	6	7	8
Designation	Minor diameter			Effective diameter			Major diameter
	Min. in	Max. in	Tol. in	Min. in	Max. in	Tol. in	Min. in
$\frac{1}{4}$ — 28 UNF — 2B	0.211 3	0.219 7	0.008 4	0.226 8	0.231 1	0.004 3	0.250 0
$\frac{5}{16}$ — 24 UNF — 2B	0.267 4	0.277 1	0.009 7	0.285 4	0.290 2	0.004 8	0.312 5
$\frac{3}{8}$ — 24 UNF — 2B	0.329 9	0.339 6	0.009 7	0.347 9	0.352 8	0.004 9	0.375 0
$\frac{7}{16}$ — 20 UNF — 2B	0.383 4	0.394 9	0.011 5	0.405 0	0.410 4	0.005 4	0.437 5
$\frac{1}{2}$ — 20 UNF — 2B	0.445 9	0.457 4	0.011 5	0.467 5	0.473 1	0.005 6	0.500 0
$\frac{9}{16}$ — 18 UNF — 2B	0.502 4	0.515 1	0.012 7	0.526 4	0.532 3	0.005 9	0.562 5
$\frac{5}{8}$ — 18 UNF — 2B	0.564 9	0.577 6	0.012 7	0.588 9	0.594 9	0.006 0	0.625 0
$\frac{3}{4}$ — 16 UNF — 2B	0.682 3	0.696 4	0.014 1	0.709 4	0.715 9	0.006 5	0.750 0
$\frac{7}{8}$ — 14 UNF — 2B	0.797 7	0.813 5	0.015 8	0.828 6	0.835 6	0.007 0	0.875 0
1 — 12 UNF — 2B	0.909 8	0.927 9	0.018 1	0.945 9	0.953 5	0.007 6	1.000 0
$1\frac{1}{8}$ — 12 UNF — 2B	1.034 8	1.052 9	0.018 1	1.070 9	1.078 7	0.007 8	1.125 0
$1\frac{1}{4}$ — 12 UNF — 2B	1.159 8	1.177 9	0.018 1	1.195 9	1.203 9	0.008 0	1.250 0
$1\frac{3}{8}$ — 12 UNF — 2B	1.284 8	1.302 9	0.018 1	1.320 9	1.329 1	0.008 2	1.375 0
$1\frac{1}{2}$ — 12 UNF — 2B	1.409 8	1.427 9	0.018 1	1.445 9	1.454 2	0.008 3	1.500 0

Table 13 Fine thread series (UNF) – Limits and tolerances for finished uncoated threads – External threads Class 3A

1	2	3	4	5	6	7	8	9	10
Designation	Major diameter			Effective diameter			Minor diameter		
	Max.	Min.	Tol.	Max.	Min.	Tol.	Max.	Min.	Tol.
	in	in	in	in	in	in	in	in	in
$\frac{1}{4}$ — 28 UNF — 3A	0.250 0	0.243 5	0.006 5	0.226 8	0.224 3	0.002 5	0.206 2	0.201 1	0.005 1
$\frac{5}{16}$ — 24 UNF — 3A	0.312 5	0.305 3	0.007 2	0.285 4	0.282 7	0.002 7	0.261 4	0.255 7	0.005 7
$\frac{3}{8}$ — 24 UNF — 3A	0.375 0	0.367 8	0.007 2	0.347 9	0.345 0	0.002 9	0.323 9	0.318 0	0.005 9
$\frac{7}{16}$ — 20 UNF — 3A	0.437 5	0.429 4	0.008 1	0.405 0	0.401 9	0.003 1	0.376 2	0.369 5	0.006 7
$\frac{1}{2}$ — 20 UNF — 3A	0.500 0	0.491 9	0.008 1	0.467 5	0.464 3	0.003 2	0.438 7	0.431 9	0.006 8
$\frac{9}{16}$ — 18 UNF — 3A	0.562 5	0.553 8	0.008 7	0.526 4	0.523 0	0.003 4	0.494 3	0.486 9	0.007 4
$\frac{5}{8}$ — 18 UNF — 3A	0.625 0	0.616 3	0.008 7	0.588 9	0.585 4	0.003 5	0.556 8	0.549 3	0.007 5
$\frac{3}{4}$ — 16 UNF — 3A	0.750 0	0.740 6	0.009 4	0.709 4	0.705 6	0.003 8	0.673 3	0.665 0	0.008 3
$\frac{7}{8}$ — 14 UNF — 3A	0.875 0	0.864 7	0.010 3	0.828 6	0.824 5	0.004 1	0.787 4	0.778 2	0.009 2
1 — 12 UNF — 3A	1.000 0	0.988 6	0.011 4	0.945 9	0.941 5	0.004 4	0.897 8	0.887 4	0.010 4
$1\frac{1}{8}$ — 12 UNF — 3A	1.125 0	1.113 6	0.011 4	1.070 9	1.066 4	0.004 5	1.022 8	1.012 3	0.010 5
$1\frac{1}{4}$ — 12 UNF — 3A	1.250 0	1.238 6	0.011 4	1.195 9	1.191 3	0.004 6	1.147 8	1.137 2	0.010 6
$1\frac{3}{8}$ — 12 UNF — 3A	1.375 0	1.363 6	0.011 4	1.320 9	1.316 2	0.004 7	1.272 8	1.262 1	0.010 7
$1\frac{1}{2}$ — 12 UNF — 3A	1.500 0	1.488 6	0.011 4	1.445 9	1.441 1	0.004 8	1.397 8	1.387 0	0.010 8

Table 14 Fine thread series (UNF) – Limits and tolerances for finished uncoated threads – Internal threads Class 3B

1	2	3	4	5	6	7	8
Designation	Minor diameter			Effective diameter			Major diameter
	Min.	Max.	Tol.	Min.	Max.	Tol.	Min.
	in	in	in	in	in	in	in
$\frac{1}{4}$ — 28 UNF — 3B	0.211 3	0.219 0	0.007 7	0.226 8	0.230 0	0.003 2	0.250 0
$\frac{5}{16}$ — 24 UNF — 3B	0.267 4	0.275 4	0.008 0	0.285 4	0.289 0	0.003 6	0.312 5
$\frac{3}{8}$ — 24 UNF — 3B	0.329 9	0.337 2	0.007 3	0.347 9	0.351 6	0.003 7	0.375 0
$\frac{7}{16}$ — 20 UNF — 3B	0.383 4	0.391 6	0.008 2	0.405 0	0.409 1	0.004 1	0.437 5
$\frac{1}{2}$ — 20 UNF — 3B	0.445 9	0.453 7	0.007 8	0.467 5	0.471 7	0.004 2	0.500 0
$\frac{9}{16}$ — 18 UNF — 3B	0.502 4	0.510 6	0.008 2	0.526 4	0.530 8	0.004 4	0.562 5
$\frac{5}{8}$ — 18 UNF — 3B	0.564 9	0.573 0	0.008 1	0.588 9	0.593 4	0.004 5	0.625 0
$\frac{3}{4}$ — 16 UNF — 3B	0.682 3	0.690 8	0.008 5	0.709 4	0.714 3	0.004 9	0.750 0
$\frac{7}{8}$ — 14 UNF — 3B	0.797 7	0.806 8	0.009 1	0.828 6	0.833 9	0.005 3	0.875 0
1 — 12 UNF — 3B	0.909 8	0.919 8	0.010 0	0.945 9	0.951 6	0.005 7	1.000 0
$1\frac{1}{8}$ — 12 UNF — 3B	1.034 8	1.044 8	0.010 0	1.070 9	1.076 8	0.005 9	1.125 0
$1\frac{1}{4}$ — 12 UNF — 3B	1.159 8	1.169 8	0.010 0	1.195 9	1.201 9	0.006 0	1.250 0
$1\frac{3}{8}$ — 12 UNF — 3B	1.284 8	1.294 8	0.010 0	1.320 9	1.327 0	0.006 1	1.375 0
$1\frac{1}{2}$ — 12 UNF — 3B	1.409 8	1.419 8	0.010 0	1.445 9	1.452 2	0.006 3	1.500 0

Table 15 Coarse thread series (UNC) – Basic dimensions

1	2	3	4	5	6	7		8	9
Nominal size	Major diameter D	Threads per inch n	Effective diameter E	Minor diameter external threads K_s	Minor diameter internal threads K_n	Lead angle at basic effective diameter λ		Section at minor diameter at $D-2h_s$	Tensile stress area A_s
in	in		in	in	in	deg	min	in ²	in ²
$\frac{1}{4}$	0.250 0	20	0.217 5	0.188 7	0.195 9	4	11	0.028 0	0.032 4
$\frac{5}{16}$	0.312 5	18	0.276 4	0.244 3	0.252 4	3	40	0.046 9	0.053 2
$\frac{3}{8}$	0.375 0	16	0.334 4	0.298 3	0.307 3	3	24	0.069 9	0.078 6
$\frac{7}{16}$	0.437 5	14	0.391 1	0.349 9	0.360 2	3	20	0.096 1	0.107 8
$\frac{1}{2}$	0.500 0	13	0.450 0	0.405 6	0.416 7	3	7	0.129 2	0.143 8
$\frac{9}{16}$	0.562 5	12	0.508 4	0.460 3	0.472 3	2	59	0.166	0.184
$\frac{5}{8}$	0.625 0	11	0.566 0	0.513 5	0.526 6	2	56	0.207	0.229
$\frac{3}{4}$	0.750 0	10	0.685 0	0.627 3	0.641 7	2	40	0.309	0.338
$\frac{7}{8}$	0.875 0	9	0.802 8	0.738 7	0.754 7	2	31	0.429	0.467
1	1.000 0	8	0.918 8	0.846 6	0.864 7	2	29	0.563	0.612
$1\frac{1}{8}$	1.125 0	7	1.032 2	0.949 7	0.970 4	2	31	0.708	0.771
$1\frac{1}{4}$	1.250 0	7	1.157 2	1.074 7	1.095 4	2	15	0.907	0.978
$1\frac{3}{8}$	1.375 0	6	1.266 7	1.170 5	1.194 6	2	24	1.076	1.166
$1\frac{1}{2}$	1.500 0	6	1.391 7	1.295 5	1.319 6	2	11	1.318	1.418
$1\frac{3}{4}$	1.750 0	5	1.620 1	1.504 6	1.533 5	2	15	1.78	1.92
2	2.000 0	$4\frac{1}{2}$	1.855 7	1.727 4	1.759 4	2	11	2.34	2.52
$2\frac{1}{4}$	2.250 0	$4\frac{1}{2}$	2.105 7	1.977 4	2.009 4	1	55	3.07	3.27
$2\frac{1}{2}$	2.500 0	4	2.337 6	2.193 3	2.229 4	1	57	3.78	4.03
$2\frac{3}{4}$	2.750 0	4	2.587 6	2.443 3	2.479 4	1	46	4.69	4.97
3	3.000 0	4	2.837 6	2.693 3	2.729 4	1	36	5.70	6.01
$3\frac{1}{4}$	3.250 0	4	3.087 6	2.943 3	2.979 4	1	29	6.80	7.14
$3\frac{1}{2}$	3.500 0	4	3.337 6	3.193 3	3.229 4	1	22	8.01	8.37
$3\frac{3}{4}$	3.750 0	4	3.587 6	3.443 3	3.479 4	1	16	9.31	9.71
4	4.000 0	4	3.837 6	3.693 3	3.729 4	1	11	10.71	11.14

NOTE 1 Areas of section at minor diameter (external threads) are calculated from the formula:

$$\frac{\pi}{4}(D - 1.226\ 87P)^2$$

NOTE 2 The tensile stress areas (external threads) are based on the mean of the basic effective diameter ($D - \frac{3}{4}H$) and the design minor diameter ($D - 1\frac{5}{12}H$), the formula being:

$$\frac{\pi}{4}(D - 0.938\ 20P)^2$$

NOTE 3 For further explanation of symbols in headings of the table see Annex D.

Table 16 Fine thread series (UNF) – Basic dimensions

1	2	3	4	5	6	7		8	9
Nominal size	Major diameter D	Threads per inch n	Effective diameter E	Minor diameter external threads K_s	Minor diameter internal threads K_n	Lead angle at basic effective diameter λ		Section at minor diameter at $D-2h_s$	Tensile stress area A_s
in	in		in	in	in	deg	min	in ²	in ²
$\frac{1}{4}$	0.250 0	28	0.226 8	0.206 2	0.211 3	2	52	0.033 3	0.036 8
$\frac{5}{16}$	0.312 5	24	0.285 4	0.261 4	0.267 4	2	40	0.053 7	0.058 7
$\frac{3}{8}$	0.375 0	24	0.347 9	0.323 9	0.329 9	2	11	0.082 4	0.088 6
$\frac{7}{16}$	0.437 5	20	0.405 0	0.376 2	0.383 4	2	15	0.111 1	0.119 8
$\frac{1}{2}$	0.500 0	20	0.467 5	0.438 7	0.445 9	1	57	0.151 1	0.161 2
$\frac{9}{16}$	0.562 5	18	0.526 4	0.494 3	0.502 4	1	55	0.192	0.205
$\frac{5}{8}$	0.625 0	18	0.588 9	0.556 8	0.564 9	1	43	0.244	0.258
$\frac{3}{4}$	0.750 0	16	0.709 4	0.673 3	0.682 3	1	36	0.356	0.375
$\frac{7}{8}$	0.875 0	14	0.828 6	0.787 4	0.797 7	1	34	0.487	0.513
1	1.000 0	12	0.945 9	0.897 8	0.909 8	1	36	0.633	0.667
$1\frac{1}{8}$	1.125 0	12	1.070 9	1.022 8	1.034 8	1	25	0.822	0.861
$1\frac{1}{4}$	1.250 0	12	1.195 9	1.147 8	1.159 8	1	16	1.035	1.078
$1\frac{3}{8}$	1.375 0	12	1.320 9	1.272 8	1.284 8	1	9	1.272	1.321
$1\frac{1}{2}$	1.500 0	12	1.445 9	1.397 8	1.409 8	1	3	1.534	1.588

NOTE See notes to Table 15.

Table 17 Extra fine thread series (UNEF) – Basic dimensions

1	2	3	4	5	6	7	8		9	10
Nominal size		Major diameter D	Threads per inch n	Effective diameter E	Minor diameter external threads K_s	Minor diameter internal threads K_n	Lead angle at basic effective diameter λ		Section at minor diameter at $D-2h_s$ A_s	Tensile stress area A_s
First choice	Second choice						deg	min		
in	in	in		in	in	in			in ²	in ²
$\frac{1}{4}$		0.250 0	32	0.229 7	0.211 7	0.216 2	2	29	0.035 2	0.038 2
$\frac{5}{16}$		0.312 5	32	0.292 2	0.274 2	0.278 7	1	57	0.059 0	0.063 0
$\frac{3}{8}$		0.375 0	32	0.354 7	0.336 7	0.341 2	1	36	0.089 0	0.093 9
$\frac{7}{16}$		0.437 5	28	0.414 3	0.393 7	0.398 8	1	34	0.121 7	0.128 2
$\frac{1}{2}$		0.500 0	28	0.476 8	0.456 2	0.461 3	1	22	0.163	0.171
$\frac{9}{16}$		0.562 5	24	0.535 4	0.511 4	0.517 4	1	25	0.205	0.215
$\frac{5}{8}$		0.625 0	24	0.597 9	0.573 9	0.579 9	1	16	0.259	0.270
	$\frac{11}{16}$	0.687 5	24	0.660 4	0.636 4	0.642 4	1	9	0.318	0.330
$\frac{3}{4}$		0.750 0	20	0.717 5	0.688 7	0.695 9	1	16	0.372	0.388
	$\frac{13}{16}$	0.812 5	20	0.780 0	0.751 2	0.758 4	1	10	0.443	0.460
$\frac{7}{8}$		0.875 0	20	0.842 5	0.813 7	0.820 9	1	5	0.520	0.539
	$\frac{15}{16}$	0.937 5	20	0.905 0	0.876 2	0.883 4	1	0	0.603	0.623
1		1.000 0	20	0.967 5	0.938 7	0.945 9	0	57	0.692	0.713
	$1\frac{1}{16}$	1.062 5	18	1.026 4	0.994 3	1.002 4	0	59	0.777	0.802
$1\frac{1}{8}$		1.125 0	18	1.088 9	1.056 8	1.064 9	0	56	0.877	0.904
	$1\frac{3}{16}$	1.187 5	18	1.151 4	1.119 3	1.127 4	0	53	0.984	1.012
$1\frac{1}{4}$		1.250 0	18	1.213 9	1.181 8	1.189 9	0	50	1.097	1.127
	$1\frac{5}{16}$	1.312 5	18	1.276 4	1.244 3	1.252 4	0	48	1.216	1.248
$1\frac{3}{8}$		1.375 0	18	1.338 9	1.306 8	1.314 9	0	45	1.341	1.374
	$1\frac{7}{16}$	1.437 5	18	1.401 4	1.369 3	1.377 4	0	43	1.473	1.507
$1\frac{1}{2}$		1.500 0	18	1.463 9	1.431 8	1.439 9	0	42	1.61	1.65
	$1\frac{9}{16}$	1.562 5	18	1.526 4	1.494 3	1.502 4	0	40	1.75	1.79
$1\frac{5}{8}$		1.625 0	18	1.588 9	1.556 8	1.564 9	0	38	1.90	1.94
	$1\frac{11}{16}$	1.687 5	18	1.651 4	1.619 3	1.627 4	0	37	2.06	2.10

NOTE See notes to Table 15.

Table 18 4-thread series (4 UN) – Basic dimensions

1	2	3	4	5	6	7		8	9
Nominal size		Major diameter <i>D</i>	Effective diameter <i>E</i>	Minor diameter external threads <i>K_s</i>	Minor diameter internal threads <i>K_n</i>	Lead angle at basic effective diameter <i>λ</i>		Section at minor diameter at <i>D-2h_s</i> <i>A_s</i>	Tensile stress area <i>A_s</i>
First choice	Second choice					deg	min		
in	in	in	in	in	in	deg	min	in ²	in ²
2½ ^{A)}		2.500 0	2.337 6	2.193 3	2.229 4	0	57	3.78	4.03
	2⅝	2.625 0	2.462 6	2.318 3	2.354 4	1	51	4.22	4.49
2¾ ^{A)}		2.750 0	2.587 6	2.443 3	2.479 4	1	46	4.69	4.97
	2⅞	2.875 0	2.712 6	2.568 3	2.604 4	1	41	5.18	5.48
3 ^{A)}		3.000 0	2.837 6	2.693 3	2.729 4	1	36	5.70	6.01
	3⅛	3.125 0	2.962 6	2.818 3	2.854 4	1	32	6.24	6.56
3¾ ^{A)}		3.250 0	3.087 6	2.943 3	2.979 4	1	29	6.80	7.14
	3⅜	3.375 0	3.212 6	3.068 3	3.104 4	1	25	7.39	7.75
3½ ^{A)}		3.500 0	3.337 6	3.193 3	3.229 4	1	22	8.01	8.37
	3⅝	3.625 0	3.462 6	3.318 3	3.354 4	1	19	8.65	9.03
3¾ ^{A)}		3.750 0	3.587 6	3.443 3	3.479 4	1	16	9.31	9.71
	3⅞	3.875 0	3.712 6	3.568 3	3.604 4	1	14	10.00	10.41
4 ^{A)}		4.000 0	3.837 6	3.693 3	3.729 4	1	11	10.71	11.14
	4⅛	4.125 0	3.962 6	3.818 3	3.854 4	1	9	11.45	11.89
4¼		4.250 0	4.087 6	3.943 3	3.979 4	1	7	12.21	12.66
	4⅜	4.375 0	4.212 6	4.068 3	4.104 4	1	5	13.00	13.46
4½		4.500 0	4.337 6	4.193 3	4.229 4	1	3	13.81	14.28
	4⅝	4.625 0	4.462 6	4.318 3	4.354 4	1	1	14.6	15.1
4¾		4.750 0	4.587 6	4.443 3	4.479 4	1	0	15.5	16.0
	4⅞	4.875 0	4.712 6	4.568 3	4.604 4	0	58	16.4	16.9
5		5.000 0	4.837 6	4.693 3	4.729 4	0	57	17.3	17.8
	5⅛	5.125 0	4.962 6	4.818 3	4.854 4	0	55	18.2	18.8
5¼		5.250 0	5.087 6	4.943 3	4.979 4	0	54	19.2	19.8
	5⅜	5.375 0	5.212 6	5.068 3	5.104 4	0	52	20.2	20.8
5½		5.500 0	5.337 6	5.193 3	5.229 4	0	51	21.2	21.8
	5⅝	5.625 0	5.462 6	5.318 3	5.354 4	0	50	22.2	22.8
5¾		5.750 0	5.587 6	5.443 3	5.479 4	0	49	23.3	23.9
	5⅞	5.875 0	5.712 6	5.568 3	5.604 4	0	48	24.4	25.0
6		6.000 0	5.837 6	5.693 3	5.729 4	0	47	25.5	26.1

NOTE See notes to Table 15.

A) These are standard sizes of the UNC series.

Table 19 6-thread series (6 UN) – Basic dimensions

1		2	3	4	5	6	7		8	9
Nominal size		Major diameter D	Effective diameter E	Minor diameter external threads K_s	Minor diameter internal threads K_n	Lead angle at basic effective diameter λ		Section at minor diameter at $D-2h_s$ A_s	Tensile stress area A_s	
First choice	Second choice					deg	min			
in	in	in	in	in	in	deg	min	in ²	in ²	
1 $\frac{3}{8}$ ^{A)}		1.375 0	1.266 7	1.170 5	1.194 6	2	24	1.076	1.166	
	1 $\frac{7}{16}$	1.437 5	1.329 2	1.233 0	1.257 1	2	17	1.194	1.289	
1 $\frac{1}{2}$ ^{A)}		1.500 0	1.391 7	1.295 5	1.319 6	2	11	1.318	1.418	
	1 $\frac{9}{16}$	1.562 5	1.454 2	1.358 0	1.382 1	2	5	1.448	1.55	
1 $\frac{5}{8}$		1.625 0	1.516 7	1.420 5	1.444 6	2	0	1.58	1.69	
	1 $\frac{11}{16}$	1.687 5	1.579 2	1.483 0	1.507 1	1	55	1.75	1.84	
1 $\frac{3}{4}$		1.750 0	1.641 7	1.545 5	1.569 6	1	51	1.88	1.99	
	1 $\frac{13}{16}$	1.812 5	1.704 2	1.608 0	1.632 1	1	47	2.03	2.15	
1 $\frac{7}{8}$		1.875 0	1.766 7	1.670 5	1.694 6	1	43	2.19	2.32	
	1 $\frac{15}{16}$	1.937 5	1.829 2	1.733 0	1.757 1	1	40	2.36	2.49	
2		2.000 0	1.891 7	1.795 5	1.819 6	1	36	2.53	2.67	
	2 $\frac{1}{8}$	2.125 0	2.016 7	1.920 5	1.944 6	1	30	2.90	3.04	
2 $\frac{1}{4}$		2.250 0	2.141 7	2.045 5	2.069 6	1	25	3.29	3.44	
	2 $\frac{3}{8}$	2.375 0	2.266 7	2.170 5	2.194 6	1	20	3.70	3.87	
2 $\frac{1}{2}$		2.500 0	2.391 7	2.295 5	2.319 6	1	16	4.14	4.31	
	2 $\frac{5}{8}$	2.625 0	2.516 7	2.420 5	2.444 6	1	12	4.60	4.79	
2 $\frac{3}{4}$		2.750 0	2.641 7	2.545 5	2.569 6	1	9	5.09	5.28	
	2 $\frac{7}{8}$	2.875 0	2.766 7	2.670 5	2.694 6	1	6	5.60	5.80	
3		3.000 0	2.891 7	2.795 5	2.819 6	1	3	6.14	6.35	
	3 $\frac{1}{8}$	3.125 0	3.016 7	2.920 5	2.944 6	1	0	6.70	6.92	
3 $\frac{1}{4}$		3.250 0	3.141 7	3.045 5	3.069 6	0	58	7.28	7.51	
	3 $\frac{3}{8}$	3.375 0	3.266 7	3.170 5	3.194 6	0	56	7.89	8.14	
3 $\frac{1}{2}$		3.500 0	3.391 7	3.295 5	3.319 6	0	54	8.53	8.78	
	3 $\frac{5}{8}$	3.625 0	3.516 7	3.420 5	3.444 6	0	52	9.19	9.45	
3 $\frac{3}{4}$		3.750 0	3.641 7	3.545 5	3.569 6	0	50	9.87	10.14	
	3 $\frac{7}{8}$	3.875 0	3.766 7	3.670 5	3.694 6	0	48	10.58	10.86	
4		4.000 0	3.891 7	3.795 5	3.819 6	0	47	11.31	11.60	
	4 $\frac{1}{8}$	4.125 0	4.016 7	3.920 5	3.944 6	0	45	12.07	12.37	
4 $\frac{1}{4}$		4.250 0	4.141 7	4.045 5	4.069 6	0	44	12.85	13.16	
	4 $\frac{3}{8}$	4.375 0	4.266 7	4.170 5	4.194 6	0	43	13.66	13.98	
4 $\frac{1}{2}$		4.500 0	4.391 7	4.295 5	4.319 6	0	42	14.49	14.82	
	4 $\frac{5}{8}$	4.625 0	4.516 7	4.420 5	4.444 6	0	40	15.3	15.7	
4 $\frac{3}{4}$		4.750 0	4.641 7	4.545 5	4.569 6	0	39	16.2	16.6	
	4 $\frac{7}{8}$	4.875 0	4.766 7	4.670 5	4.694 6	0	38	17.1	17.5	
5		5.000 0	4.891 7	4.795 5	4.819 6	0	37	18.1	18.4	
	5 $\frac{1}{8}$	5.125 0	5.016 7	4.920 5	4.944 6	0	36	19.0	19.4	
5 $\frac{1}{4}$		5.250 0	5.141 7	5.045 5	5.069 6	0	35	20.0	20.4	
	5 $\frac{3}{8}$	5.375 0	5.266 7	5.170 5	5.194 6	0	35	21.0	21.4	
5 $\frac{1}{2}$		5.500 0	5.391 7	5.295 5	5.319 6	0	34	22.0	22.4	
	5 $\frac{5}{8}$	5.625 0	5.516 7	5.420 5	5.444 6	0	33	23.0	23.5	
5 $\frac{3}{4}$		5.750 0	5.641 7	5.545 5	5.569 6	0	32	24.1	24.6	
	5 $\frac{7}{8}$	5.875 0	5.766 7	5.670 5	5.694 6	0	32	25.2	25.7	
6		6.000 0	5.891 7	5.795 5	5.819 6	0	31	26.4	26.8	

NOTE See notes to Table 15.

A) These are standard sizes of the UNC series.

Table 20 8-thread series (8 UN) – Basic dimensions

1	2	3	4	5	6	7		8	9
Nominal size		Major diameter D	Effective diameter E	Minor diameter external threads K_s	Minor diameter internal threads K_n	Lead angle at basic effective diameter λ		Section at minor diameter at $D-2h_s$ A_s	Tensile stress area A_s
First choice	Second choice					deg	min		
in	in	in	in	in	in			in ²	in ²
1 ^{A)}		1.000 0	0.918 8	0.846 6	0.864 7	2	29	0.563	0.612
	1 $\frac{1}{16}$	1.062 5	0.981 3	0.909 1	0.927 2	2	19	0.649	0.702
1 $\frac{1}{8}$		1.125 0	1.043 8	0.971 6	0.989 7	2	11	0.741	0.798
	1 $\frac{3}{16}$	1.187 5	1.106 3	1.034 1	1.052 2	2	4	0.840	0.900
1 $\frac{1}{4}$		1.250 0	1.168 8	1.096 6	1.114 7	1	57	0.944	1.008
	1 $\frac{5}{16}$	1.312 5	1.231 3	1.159 1	1.177 2	1	51	1.055	1.122
1 $\frac{3}{8}$		1.375 0	1.293 8	1.221 6	1.239 7	1	46	1.172	1.242
	1 $\frac{7}{16}$	1.437 5	1.356 3	1.284 1	1.302 2	1	41	1.295	1.369
1 $\frac{1}{2}$		1.500 0	1.418 8	1.346 6	1.364 7	1	36	1.424	1.502
	1 $\frac{9}{16}$	1.562 5	1.481 3	1.409 1	1.427 2	1	32	1.56	1.64
1 $\frac{5}{8}$		1.625 0	1.543 8	1.471 6	1.489 7	1	29	1.70	1.79
	1 $\frac{11}{16}$	1.687 5	1.606 3	1.534 1	1.552 2	1	25	1.85	1.94
1 $\frac{3}{4}$		1.750 0	1.668 8	1.596 6	1.614 7	1	22	2.00	2.09
	1 $\frac{13}{16}$	1.812 5	1.731 3	1.659 1	1.677 2	1	19	2.16	2.26
1 $\frac{7}{8}$		1.875 0	1.793 8	1.721 6	1.739 7	1	16	2.33	2.43
	1 $\frac{15}{16}$	1.937 5	1.856 3	1.784 1	1.802 2	1	14	2.50	2.60
2		2.000 0	1.918 8	1.846 6	1.864 7	1	11	2.68	2.78
	2 $\frac{1}{8}$	2.125 0	2.043 8	1.971 6	1.989 7	1	7	3.05	3.17
2 $\frac{1}{4}$		2.250 0	2.168 8	2.096 6	2.114 7	1	3	3.45	3.57
	2 $\frac{3}{8}$	2.375 0	2.293 8	2.221 6	2.239 7	1	0	3.88	4.00
2 $\frac{1}{2}$		2.500 0	2.418 8	2.346 6	2.364 7	0	57	4.32	4.46
	2 $\frac{5}{8}$	2.625 0	2.543 8	2.471 6	2.489 7	0	54	4.80	4.94
2 $\frac{3}{4}$		2.750 0	2.668 8	2.596 6	2.614 7	0	51	5.30	5.44
	2 $\frac{7}{8}$	2.875 0	2.793 8	2.721 6	2.739 7	0	49	5.82	5.97
3		3.000 0	2.918 8	2.846 6	2.864 7	0	47	6.36	6.53
	3 $\frac{1}{8}$	3.125 0	3.043 8	2.971 6	2.989 7	0	45	6.94	7.11
3 $\frac{1}{4}$		3.250 0	3.168 8	3.096 6	3.114 7	0	43	7.53	7.71
	3 $\frac{3}{8}$	3.375 0	3.293 8	3.221 6	3.239 7	0	42	8.15	8.34
3 $\frac{1}{2}$		3.500 0	3.418 8	3.346 6	3.364 7	0	40	8.80	8.99
	3 $\frac{5}{8}$	3.625 0	3.543 8	3.471 6	3.489 7	0	39	9.47	9.66
3 $\frac{3}{4}$		3.750 0	3.668 8	3.596 6	3.614 7	0	37	10.16	10.36
	3 $\frac{7}{8}$	3.875 0	3.793 8	3.721 6	3.739 7	0	36	10.88	11.09
4		4.000 0	3.918 8	3.846 6	3.864 7	0	35	11.62	11.84
	4 $\frac{1}{8}$	4.125 0	4.043 8	3.971 6	3.989 7	0	34	12.39	12.61
4 $\frac{1}{4}$		4.250 0	4.168 8	4.096 6	4.114 7	0	33	13.18	13.41
	4 $\frac{3}{8}$	4.375 0	4.293 8	4.221 6	4.239 7	0	32	14.00	14.24
4 $\frac{1}{2}$		4.500 0	4.418 8	4.346 6	4.364 7	0	31	14.84	15.09
	4 $\frac{5}{8}$	4.625 0	4.543 8	4.471 6	4.489 7	0	30	15.7	16.0
4 $\frac{3}{4}$		4.750 0	4.668 8	4.596 6	4.614 7	0	29	16.6	16.9
	4 $\frac{7}{8}$	4.875 0	4.793 8	4.721 6	4.739 7	0	29	17.5	17.8
5		5.000 0	4.918 8	4.846 6	4.864 7	0	28	18.4	18.7
	5 $\frac{1}{8}$	5.125 0	5.043 8	4.971 6	4.989 7	0	27	19.4	19.7
5 $\frac{1}{4}$		5.250 0	5.168 8	5.096 6	5.114 7	0	26	20.4	20.7
	5 $\frac{3}{8}$	5.375 0	5.293 8	5.221 6	5.239 7	0	26	21.4	21.7
5 $\frac{1}{2}$		5.500 0	5.418 8	5.346 6	5.364 7	0	25	22.5	22.8
	5 $\frac{5}{8}$	5.625 0	5.543 8	5.471 6	5.489 7	0	25	23.5	23.8
5 $\frac{3}{4}$		5.750 0	5.668 8	5.596 6	5.614 7	0	24	24.6	24.9
	5 $\frac{7}{8}$	5.875 0	5.793 8	5.721 6	5.739 7	0	24	25.7	26.0
6		6.000 0	5.918 8	5.846 6	5.864 7	0	23	26.8	27.2

NOTE See notes to Table 15.

A) This is a standard size of the UNC series.

Table 21 12-thread series (12 UN) – Basic dimensions

1	2	3	4	5	6	7		8	9
Nominal size		Major diameter D	Effective diameter E	Minor diameter external threads K_s	Minor diameter internal threads K_n	Lead angle at basic effective diameter		Section at minor diameter at $D-2h_s$	Tensile stress area A_s
First choice	Second choice					λ	λ		
in	in	in	in	in	in	deg	min	in ²	in ²
$\frac{9}{16}$ ^{A)}		0.562 5	0.508 4	0.460 3	0.472 3	2	59	0.166	0.184
$\frac{5}{8}$	$\frac{11}{16}$	0.625 0	0.570 9	0.522 8	0.534 8	2	40	0.215	0.235
$\frac{3}{4}$	$\frac{13}{16}$	0.687 5	0.633 4	0.585 3	0.597 3	2	24	0.269	0.292
$\frac{7}{8}$	$\frac{15}{16}$	0.750 0	0.695 9	0.647 8	0.659 8	2	11	0.330	0.354
		0.812 5	0.758 4	0.710 3	0.722 3	2	0	0.396	0.424
		0.875 0	0.820 9	0.772 8	0.784 8	1	51	0.469	0.499
		0.937 5	0.883 4	0.835 3	0.847 3	1	43	0.548	0.580
1 ^{A)}	$1\frac{1}{16}$	1.000 0	0.945 9	0.897 8	0.909 8	1	36	0.633	0.667
		1.062 5	1.008 4	0.960 3	0.972 3	1	30	0.724	0.761
1 $\frac{1}{8}$ ^{A)}	$1\frac{3}{16}$	1.125 0	1.070 9	1.022 8	1.034 8	1	25	0.822	0.861
		1.187 5	1.133 4	1.085 3	1.097 3	1	20	0.925	0.966
1 $\frac{1}{4}$ ^{A)}	$1\frac{5}{16}$	1.250 0	1.195 9	1.147 8	1.159 8	1	16	1.035	1.078
		1.312 5	1.258 4	1.210 3	1.222 3	1	12	1.150	1.197
1 $\frac{3}{8}$ ^{A)}	$1\frac{7}{16}$	1.375 0	1.320 9	1.272 8	1.284 8	1	9	1.272	1.321
		1.437 5	1.383 4	1.335 3	1.347 3	1	6	1.400	1.451
1 $\frac{1}{2}$ ^{A)}	$1\frac{9}{16}$	1.500 0	1.445 9	1.397 8	1.409 8	1	3	1.53	1.59
		1.562 5	1.508 4	1.460 3	1.472 3	1	0	1.67	1.73
1 $\frac{5}{8}$	$1\frac{11}{16}$	1.625 0	1.570 9	1.522 8	1.534 8	0	58	1.82	1.88
		1.687 5	1.633 4	1.585 3	1.597 3	0	56	1.97	2.03
1 $\frac{3}{4}$	$1\frac{13}{16}$	1.750 0	1.695 9	1.647 8	1.659 8	0	54	2.13	2.20
		1.812 5	1.758 4	1.710 3	1.722 3	0	52	2.30	2.36
1 $\frac{7}{8}$	$1\frac{15}{16}$	1.875 0	1.820 9	1.772 8	1.784 8	0	50	2.47	2.54
		1.937 5	1.883 4	1.835 3	1.847 3	0	48	2.65	2.72
2		2.000 0	1.945 9	1.897 8	1.909 8	0	47	2.83	2.90
	$2\frac{1}{8}$	2.125 0	2.070 9	2.022 8	2.034 8	0	44	3.21	3.29
2 $\frac{1}{4}$		2.250 0	2.195 9	2.147 8	2.159 8	0	42	3.62	3.70
	$2\frac{3}{8}$	2.375 0	2.320 9	2.272 8	2.284 8	0	39	4.06	4.14
2 $\frac{1}{2}$		2.500 0	2.445 9	2.397 8	2.409 8	0	37	4.52	4.61
	$2\frac{5}{8}$	2.625 0	2.570 9	2.522 8	2.534 8	0	35	5.00	5.09
2 $\frac{3}{4}$		2.750 0	2.695 9	2.647 8	2.659 8	0	34	5.51	5.61
	$2\frac{7}{8}$	2.875 0	2.820 9	2.772 8	2.784 8	0	32	6.04	6.14
3		3.000 0	2.945 9	2.897 8	2.909 8	0	31	6.60	6.70
	$3\frac{1}{8}$	3.125 0	3.070 9	3.022 8	3.034 8	0	30	7.18	7.29
3 $\frac{1}{4}$		3.250 0	3.195 9	3.147 8	3.159 8	0	29	7.78	7.90
	$3\frac{3}{8}$	3.375 0	3.320 9	3.272 8	3.284 8	0	27	8.41	8.54
3 $\frac{1}{2}$		3.500 0	3.445 9	3.397 8	3.409 8	0	26	9.07	9.20
	$3\frac{5}{8}$	3.625 0	3.570 9	3.522 8	3.534 8	0	26	9.75	9.88
3 $\frac{3}{4}$		3.750 0	3.695 9	3.647 8	3.659 8	0	25	10.45	10.59
	$3\frac{7}{8}$	3.875 0	3.820 9	3.772 8	3.784 8	0	24	11.18	11.32
4		4.000 0	3.945 9	3.897 8	3.909 8	0	23	11.93	12.08
	$4\frac{1}{8}$	4.125 0	4.070 9	4.022 8	4.034 8	0	22	12.71	12.86
4 $\frac{1}{4}$		4.250 0	4.195 9	4.147 8	4.159 8	0	22	13.51	13.67
	$4\frac{3}{8}$	4.375 0	4.320 9	4.272 8	4.284 8	0	21	14.34	14.50
4 $\frac{1}{2}$		4.500 0	4.445 9	4.397 8	4.409 8	0	21	15.2	15.4
	$4\frac{5}{8}$	4.625 0	4.570 9	4.522 8	4.534 8	0	20	16.1	16.2
4 $\frac{3}{4}$		4.750 0	4.695 9	4.647 8	4.659 8	0	19	17.0	17.1
	$4\frac{7}{8}$	4.875 0	4.820 9	4.772 8	4.784 8	0	19	17.9	18.1
5		5.000 0	4.945 9	4.897 8	4.909 8	0	18	18.8	19.0
	$5\frac{1}{8}$	5.125 0	5.070 9	5.022 8	5.034 8	0	18	19.8	20.0
5 $\frac{1}{4}$		5.250 0	5.195 9	5.147 8	5.159 8	0	18	20.8	21.0
	$5\frac{3}{8}$	5.375 0	5.320 9	5.272 8	5.284 8	0	17	21.8	22.0
5 $\frac{1}{2}$		5.500 0	5.445 9	5.397 8	5.409 8	0	17	22.9	23.1
	$5\frac{5}{8}$	5.625 0	5.570 9	5.522 8	5.534 8	0	16	24.0	24.2
5 $\frac{3}{4}$		5.750 0	5.695 9	5.647 8	5.659 8	0	16	25.1	25.3
	$5\frac{7}{8}$	5.875 0	5.820 9	5.772 8	5.784 8	0	16	26.2	26.4
6		6.000 0	5.945 9	5.897 8	5.909 8	0	15	27.3	27.5

NOTE See notes to Table 15.

A) These are standard sizes of the UNC or UNF series.

Table 22 16-thread series (16 UN) – Basic dimensions

1		2	3	4	5	6		7		8	9
Nominal size		Major diameter D	Effective diameter E	Minor diameter external threads K_s	Minor diameter internal threads K_n	Lead angle at basic effective diameter λ		Section at minor diameter at $D-2h_s$ A_s	Tensile stress area A_s		
First choice	Second choice					deg	min				
in	in	in	in	in	in	deg	min	in ²	in ²		
$\frac{3}{8}$ ^{A)}	$\frac{7}{16}$	0.375 0	0.334 4	0.298 3	0.307 3	3	24	0.069 9	0.078 6		
		0.437 5	0.396 9	0.360 8	0.369 8	2	52	0.102 3	0.112 7		
		0.500 0	0.459 4	0.423 3	0.432 3	2	29	0.140 7	0.153		
		0.562 5	0.521 9	0.485 8	0.494 8	2	11	0.185	0.199		
		0.625 0	0.584 4	0.548 3	0.557 3	1	57	0.236	0.252		
$\frac{3}{4}$ ^{A)}	$\frac{11}{16}$	0.687 5	0.646 9	0.610 8	0.619 8	1	46	0.293	0.311		
		0.750 0	0.709 4	0.673 3	0.682 3	1	36	0.356	0.375		
		0.812 5	0.771 9	0.735 8	0.744 8	1	29	0.425	0.446		
		0.875 0	0.834 4	0.798 3	0.807 3	1	22	0.501	0.523		
		0.937 5	0.896 9	0.860 8	0.869 8	1	16	0.582	0.607		
1	$1\frac{1}{16}$	1.000 0	0.959 4	0.923 3	0.932 3	1	11	0.670	0.696		
		1.062 5	1.021 9	0.985 8	0.994 8	1	7	0.763	0.791		
$1\frac{1}{8}$	$1\frac{3}{16}$	1.125 0	1.084 4	1.048 3	1.057 3	1	3	0.863	0.893		
		1.187 5	1.146 9	1.110 8	1.119 8	1	0	0.969	1.001		
$1\frac{1}{4}$	$1\frac{5}{16}$	1.250 0	1.209 4	1.173 3	1.182 3	0	57	1.081	1.115		
		1.312 5	1.271 9	1.235 8	1.244 8	0	54	1.199	1.235		
$1\frac{3}{8}$	$1\frac{7}{16}$	1.375 0	1.334 4	1.298 3	1.307 3	0	51	1.324	1.361		
		1.437 5	1.396 9	1.360 8	1.369 8	0	49	1.454	1.493		
$1\frac{1}{2}$	$1\frac{9}{16}$	1.500 0	1.459 4	1.423 3	1.432 3	0	47	1.59	1.63		
		1.562 5	1.521 9	1.485 8	1.494 8	0	45	1.73	1.78		
$1\frac{5}{8}$	$1\frac{11}{16}$	1.625 0	1.584 4	1.548 3	1.557 3	0	43	1.88	1.93		
		1.687 5	1.646 9	1.610 8	1.619 8	0	42	2.04	2.08		
$1\frac{3}{4}$	$1\frac{13}{16}$	1.750 0	1.709 4	1.673 3	1.682 3	0	40	2.20	2.25		
		1.812 5	1.771 9	1.735 8	1.744 8	0	39	2.37	2.42		
$1\frac{7}{8}$	$1\frac{15}{16}$	1.875 0	1.834 4	1.798 3	1.807 3	0	37	2.54	2.59		
		1.937 5	1.896 9	1.860 8	1.869 8	0	36	2.72	2.77		
2	$2\frac{1}{8}$	2.000 0	1.959 4	1.923 3	1.932 3	0	35	2.91	2.96		
		2.125 0	2.084 4	2.048 3	2.057 3	0	33	3.30	3.35		
$2\frac{1}{4}$	$2\frac{3}{8}$	2.250 0	2.209 4	2.173 3	2.182 3	0	31	3.71	3.77		
		2.375 0	2.334 4	2.298 3	2.307 3	0	29	4.15	4.21		
$2\frac{1}{2}$	$2\frac{5}{8}$	2.500 0	2.459 4	2.423 3	2.432 3	0	28	4.61	4.68		
		2.625 0	2.584 4	2.548 3	2.557 3	0	26	5.10	5.17		
$2\frac{3}{4}$	$2\frac{7}{8}$	2.750 0	2.709 4	2.673 3	2.682 3	0	25	5.61	5.69		
		2.875 0	2.834 4	2.798 3	2.807 3	0	24	6.15	6.23		
3	$3\frac{1}{8}$	3.000 0	2.959 4	2.923 3	2.932 3	0	23	6.71	6.79		
		3.125 0	3.084 4	3.048 3	3.057 3	0	22	7.30	7.38		
$3\frac{1}{4}$	$3\frac{3}{8}$	3.250 0	3.209 4	3.173 3	3.182 3	0	21	7.91	8.00		
		3.375 0	3.334 4	3.298 3	3.307 3	0	21	8.54	8.64		
$3\frac{1}{2}$	$3\frac{5}{8}$	3.500 0	3.459 4	3.423 3	3.432 3	0	20	9.20	9.30		
		3.625 0	3.584 4	3.548 3	3.557 3	0	19	9.89	9.99		
$3\frac{3}{4}$	$3\frac{7}{8}$	3.750 0	3.709 4	3.673 3	3.682 3	0	18	10.60	10.70		
		3.875 0	3.834 4	3.798 3	3.807 3	0	18	11.33	11.44		
4	$4\frac{1}{8}$	4.000 0	3.959 4	3.923 3	3.932 3	0	17	12.09	12.20		
		4.125 0	4.084 4	4.048 3	4.057 3	0	17	12.87	12.99		
$4\frac{1}{4}$	$4\frac{3}{8}$	4.250 0	4.209 4	4.173 3	4.182 3	0	16	13.68	13.80		
		4.375 0	4.334 4	4.298 3	4.307 3	0	16	14.51	14.63		
$4\frac{1}{2}$	$4\frac{5}{8}$	4.500 0	4.459 4	4.423 3	4.432 3	0	15	15.37	15.5		
		4.625 0	4.584 4	4.548 3	4.557 3	0	15	16.2	16.4		
$4\frac{3}{4}$	$4\frac{7}{8}$	4.750 0	4.709 4	4.673 3	4.682 3	0	15	17.2	17.3		
		4.875 0	4.834 4	4.798 3	4.807 3	0	14	18.1	18.2		
5	$5\frac{1}{8}$	5.000 0	4.959 4	4.923 3	4.932 3	0	14	19.0	19.2		
		5.125 0	5.084 4	5.048 3	5.057 3	0	13	20.0	20.2		
$5\frac{1}{4}$	$5\frac{3}{8}$	5.250 0	5.209 4	5.173 3	5.182 3	0	13	21.0	21.2		
		5.375 0	5.334 4	5.298 3	5.307 3	0	13	22.0	22.2		
$5\frac{1}{2}$	$5\frac{5}{8}$	5.500 0	5.459 4	5.423 3	5.432 3	0	13	23.1	23.3		
		5.625 0	5.584 4	5.548 3	5.557 3	0	12	24.2	24.3		
$5\frac{3}{4}$	$5\frac{7}{8}$	5.750 0	5.709 4	5.673 3	5.682 3	0	12	25.3	25.4		
		5.875 0	5.834 4	5.798 3	5.807 3	0	12	26.4	26.6		
6		6.000 0	5.959 4	5.923 3	5.932 3	0	11	27.6	27.7		

NOTE See notes to Table 15.

^{A)} These are standard sizes of the UNC or UNF series.

Table 23 20-thread series (20 UN) – Basic dimensions

1	2	3	4	5	6	7		8	9
Nominal size		Major diameter D	Effective diameter E	Minor diameter external threads K_s	Minor diameter internal threads K_n	Lead angle at basic effective diameter λ		Section at minor diameter at $D-2h_s$ A_s	Tensile stress area A_s
First choice	Second choice					deg	min		
in	in	in	in	in	in	deg	min	in ²	in ²
$\frac{1}{4}$ ^{A)}		0.250 0	0.217 5	0.188 7	0.195 9	4	11	0.028 0	0.032 4
$\frac{5}{16}$		0.312 5	0.280 0	0.251 2	0.258 4	3	15	0.049 5	0.055 4
$\frac{3}{8}$		0.375 0	0.342 5	0.313 7	0.320 9	2	40	0.077 3	0.084 5
$\frac{7}{16}$ ^{A)}		0.437 5	0.405 0	0.376 2	0.383 4	2	15	0.111 2	0.119 8
$\frac{1}{2}$ ^{A)}		0.500 0	0.467 5	0.438 7	0.445 9	1	57	0.151 1	0.161
$\frac{9}{16}$		0.562 5	0.530 0	0.501 2	0.508 4	1	43	0.197	0.209
$\frac{5}{8}$		0.625 0	0.592 5	0.563 7	0.570 9	1	32	0.249	0.262
	$\frac{11}{16}$	0.687 5	0.655 0	0.626 2	0.633 4	1	24	0.308	0.322
$\frac{3}{4}$ ^{A)}		0.750 0	0.717 5	0.688 7	0.695 9	1	16	0.372	0.388
	$\frac{13}{16}$ ^{A)}	0.812 5	0.780 0	0.751 2	0.758 4	1	10	0.443	0.460
$\frac{7}{8}$ ^{A)}		0.875 0	0.842 5	0.813 7	0.820 9	1	5	0.520	0.539
	$\frac{15}{16}$ ^{A)}	0.937 5	0.905 0	0.876 2	0.883 4	1	0	0.603	0.623
1 ^{A)}		1.000 0	0.967 5	0.938 7	0.945 9	0	57	0.692	0.713
	$1\frac{1}{16}$	1.062 5	1.030 0	1.001 2	1.008 4	0	53	0.787	0.810
$1\frac{1}{8}$		1.125 0	1.092 5	1.063 7	1.070 9	0	50	0.889	0.913
	$1\frac{3}{16}$	1.187 5	1.155 0	1.126 2	1.133 4	0	47	0.996	1.022
$1\frac{1}{4}$		1.250 0	1.217 5	1.188 7	1.195 9	0	45	1.110	1.136
	$1\frac{5}{16}$	1.312 5	1.280 0	1.251 2	1.258 4	0	43	1.230	1.258
$1\frac{3}{8}$		1.375 0	1.342 5	1.313 7	1.320 9	0	41	1.355	1.385
	$1\frac{7}{16}$	1.437 5	1.405 0	1.376 2	1.383 4	0	39	1.487	1.52
$1\frac{1}{2}$		1.500 0	1.467 5	1.438 7	1.445 9	0	37	1.63	1.66
	$1\frac{9}{16}$	1.562 5	1.530 0	1.501 2	1.508 4	0	36	1.77	1.80
$1\frac{5}{8}$		1.625 0	1.592 5	1.563 7	1.570 9	0	34	1.92	1.96
	$1\frac{11}{16}$	1.687 5	1.655 0	1.626 2	1.633 4	0	33	2.08	2.11
$1\frac{3}{4}$		1.750 0	1.717 5	1.688 7	1.695 9	0	32	2.24	2.28
	$1\frac{13}{16}$	1.812 5	1.780 0	1.751 2	1.758 4	0	31	2.41	2.45
$1\frac{7}{8}$		1.875 0	1.842 5	1.813 7	1.820 9	0	30	2.58	2.62
	$1\frac{15}{16}$	1.937 5	1.905 0	1.876 2	1.883 4	0	29	2.76	2.81
2		2.000 0	1.967 5	1.938 7	1.945 9	0	28	2.95	3.00
	$2\frac{1}{8}$	2.125 0	2.092 5	2.063 7	2.070 9	0	26	3.34	3.39
$2\frac{1}{4}$		2.250 0	2.217 5	2.188 7	2.195 9	0	25	3.76	3.81
	$2\frac{3}{8}$	2.375 0	2.342 5	2.313 7	2.320 9	0	23	4.20	4.26
$2\frac{1}{2}$		2.500 0	2.467 5	2.438 7	2.445 9	0	22	4.67	4.73
	$2\frac{5}{8}$	2.625 0	2.592 5	2.563 7	2.570 9	0	21	5.16	5.22
$2\frac{3}{4}$		2.750 0	2.717 5	2.688 7	2.695 9	0	20	5.68	5.74
	$2\frac{7}{8}$	2.875 0	2.842 5	2.813 7	2.820 9	0	19	6.22	6.28
3		3.000 0	2.967 5	2.938 7	2.945 9	0	18	6.78	6.85

NOTE See notes to Table 15.

A) These are standard sizes of the UNC, UNF or UNEF series.

Table 24 28-thread series (28 UN) – Basic dimensions

1	2	3	4	5	6	7		8	9
Nominal size		Major diameter D	Effective diameter E	Minor diameter external threads K_s	Minor diameter internal threads K_n	Lead angle at basic effective diameter λ		Section at minor diameter at $D-2h_s$ A_s	Tensile stress area A_s
First choice	Second choice					deg	min		
in	in	in	in	in	in	deg	min	in ²	in ²
$\frac{1}{4}$ ^{A)}		0.250 0	0.226 8	0.206 2	0.211 3	2	52	0.033 4	0.036 8
$\frac{5}{16}$		0.312 5	0.289 3	0.268 7	0.273 8	2	15	0.056 7	0.061 1
$\frac{3}{8}$		0.375 0	0.351 8	0.331 2	0.336 3	1	51	0.086 1	0.091 6
$\frac{7}{16}$ ^{A)}		0.437 5	0.414 3	0.393 7	0.398 8	1	34	0.121 7	0.128 2
$\frac{1}{2}$ ^{A)}		0.500 0	0.476 8	0.456 2	0.461 3	1	22	0.163	0.171
$\frac{9}{16}$		0.562 5	0.539 3	0.518 7	0.523 8	1	12	0.211	0.220
$\frac{5}{8}$		0.625 0	0.601 8	0.581 2	0.586 3	1	5	0.265	0.275
	$\frac{11}{16}$	0.687 5	0.664 3	0.643 7	0.648 8	0	59	0.325	0.336
$\frac{3}{4}$		0.750 0	0.726 8	0.706 2	0.711 3	0	54	0.392	0.403
	$\frac{13}{16}$	0.812 5	0.789 3	0.768 7	0.773 8	0	50	0.464	0.477
$\frac{7}{8}$		0.875 0	0.851 8	0.831 2	0.836 3	0	46	0.543	0.556
	$\frac{15}{16}$	0.937 5	0.914 3	0.893 7	0.898 8	0	43	0.627	0.642
1		1.000 0	0.976 8	0.956 2	0.961 3	0	40	0.718	0.734
	$1\frac{1}{16}$	1.062 5	1.039 3	1.018 7	1.023 8	0	38	0.815	0.832
$1\frac{1}{8}$		1.125 0	1.101 8	1.081 2	1.086 3	0	35	0.918	0.936
	$1\frac{3}{16}$	1.187 5	1.164 3	1.143 7	1.148 8	0	34	1.027	1.046
$1\frac{1}{4}$		1.250 0	1.226 8	1.206 2	1.211 3	0	32	1.143	1.162
	$1\frac{5}{16}$	1.312 5	1.289 3	1.268 7	1.273 8	0	30	1.264	1.285
$1\frac{3}{8}$		1.375 0	1.351 8	1.331 2	1.336 3	0	29	1.392	1.413
	$1\frac{7}{16}$	1.437 5	1.414 3	1.393 7	1.398 8	0	28	1.53	1.55
$1\frac{1}{2}$		1.500 0	1.476 8	1.456 2	1.461 3	0	26	1.67	1.69

NOTE See notes to Table 15.

^{A)} These are standard sizes of the UNF or UNEF series.

Table 25 32-thread series (32 UN) – Basic dimensions

1	2	3	4	5	6	7		8	9
Nominal size		Major diameter D	Effective diameter E	Minor diameter external threads K_s	Minor diameter internal threads K_n	Lead angle at basic effective diameter λ		Section at minor diameter at $D-2h_s$ A_s	Tensile stress area A_s
First choice	Second choice					deg	min		
in	in	in	in	in	in			in ²	in ²
$\frac{1}{4}$ ^{A)}		0.250 0	0.229 7	0.211 7	0.216 2	2	29	0.035 2	0.038 2
$\frac{5}{16}$ ^{A)}		0.312 5	0.292 2	0.274 2	0.278 7	1	57	0.059 0	0.063 0
$\frac{3}{8}$ ^{A)}		0.375 0	0.354 7	0.336 7	0.341 2	1	36	0.089 0	0.093 9
$\frac{7}{16}$		0.437 5	0.417 2	0.399 2	0.403 7	1	22	0.125 1	0.130 9
$\frac{1}{2}$		0.500 0	0.479 7	0.461 7	0.466 2	1	11	0.167	0.174
$\frac{9}{16}$		0.562 5	0.542 2	0.524 2	0.528 7	1	3	0.216	0.223
$\frac{5}{8}$		0.625 0	0.604 7	0.586 7	0.591 2	0	57	0.270	0.279
	$\frac{11}{16}$	0.687 5	0.667 2	0.649 2	0.653 7	0	51	0.331	0.340
$\frac{3}{4}$		0.750 0	0.729 7	0.711 7	0.716 2	0	47	0.398	0.408
	$\frac{13}{16}$	0.812 5	0.792 2	0.774 2	0.778 7	0	43	0.471	0.482
$\frac{7}{8}$		0.875 0	0.854 7	0.836 7	0.841 2	0	40	0.550	0.562
	$\frac{15}{16}$	0.937 5	0.917 2	0.899 2	0.903 7	0	37	0.635	0.648
1		1.000 0	0.979 7	0.961 7	0.966 2	0	35	0.726	0.740

NOTE See notes to Table 15.

A) These are standard sizes of the UNEF series.

Table 26 Thread data for unified thread form

1	2	3	4	5	6	7	8	9	10	11	12	13	14
Threads per inch	Pitch	Flat at internal thread crest	Flat at internal thread root and external thread crest	Height of sharp V-thread	Truncation of internal thread root and external thread crest	Truncation of external thread root	Truncation of internal thread crest	Addendum of external thread	Height of internal thread and depth of thread engagement	Height of external thread	Twice the external thread addendum	Double height of internal thread	Double height of external thread
n	P	F_{cn} $P/4$	F_{rn} F_{cs} $P/8$	H	F_{rn} F_{cs} $H/8$	S_{rs} $H/6$	F_{cn} $H/4$	h_{as} $\frac{3}{8}H$	h_n h_c $\frac{5}{8}H$	h_s $\frac{17}{24}H$	h_b $2h_{as}$ $\frac{3}{4}H$	$2h_n$ $1\frac{1}{4}H$	$1\frac{5}{12}H$
	in	in	in	in	in	in	in	in	in	in	in	in	in
40	0.025 000	0.006 25	0.003 12	0.021 651	0.002 71	0.003 61	0.005 41	0.008 12	0.013 53	0.015 34	0.016 238	0.027 06	0.030 67
36	0.027 778	0.006 94	0.003 47	0.024 056	0.003 01	0.004 01	0.006 01	0.009 02	0.015 04	0.017 04	0.018 042	0.030 07	0.034 08
32	0.031 250	0.007 81	0.003 91	0.027 063	0.003 38	0.004 51	0.006 77	0.010 15	0.016 91	0.019 17	0.020 297	0.033 83	0.038 34
28	0.035 714	0.008 93	0.004 46	0.030 929	0.003 87	0.005 15	0.007 73	0.011 60	0.019 33	0.021 91	0.023 197	0.038 66	0.043 82
24	0.041 667	0.010 42	0.005 21	0.036 084	0.004 51	0.006 01	0.009 02	0.013 53	0.022 55	0.025 56	0.027 063	0.045 11	0.051 12
20	0.050 000	0.012 50	0.006 25	0.043 301	0.005 41	0.007 22	0.010 83	0.016 24	0.027 06	0.030 67	0.032 476	0.054 13	0.061 34
18	0.055 556	0.013 89	0.006 94	0.048 113	0.006 01	0.008 02	0.012 03	0.018 04	0.030 07	0.034 08	0.036 084	0.060 14	0.068 16
16	0.062 500	0.015 62	0.007 81	0.054 127	0.006 77	0.009 02	0.013 53	0.020 30	0.033 83	0.038 34	0.040 595	0.067 66	0.076 68
14	0.071 429	0.017 86	0.008 93	0.061 859	0.007 73	0.010 31	0.015 46	0.023 20	0.038 66	0.043 82	0.046 394	0.077 32	0.087 63
13	0.076 923	0.019 23	0.009 62	0.066 617	0.008 33	0.011 10	0.016 65	0.024 98	0.041 64	0.047 19	0.049 963	0.083 27	0.094 37
12	0.083 333	0.020 83	0.010 42	0.072 169	0.009 02	0.012 03	0.018 04	0.027 06	0.045 11	0.051 12	0.054 127	0.090 21	0.102 24
11	0.090 909	0.022 73	0.011 36	0.078 730	0.009 84	0.013 12	0.019 68	0.029 52	0.049 21	0.055 77	0.059 047	0.098 41	0.111 53
10	0.100 000	0.025 00	0.012 50	0.086 603	0.010 83	0.014 43	0.021 65	0.032 48	0.054 13	0.061 34	0.064 952	0.108 25	0.122 69
9	0.111 111	0.027 78	0.013 89	0.096 225	0.012 03	0.016 04	0.024 06	0.036 08	0.060 14	0.068 16	0.072 169	0.120 28	0.136 32
8	0.125 000	0.031 25	0.015 62	0.108 253	0.013 53	0.018 04	0.027 06	0.040 59	0.067 66	0.076 68	0.081 190	0.135 32	0.153 36
7	0.142 857	0.035 71	0.017 86	0.123 718	0.015 46	0.020 62	0.030 93	0.046 39	0.077 32	0.087 63	0.092 788	0.154 65	0.175 27
6	0.166 667	0.041 67	0.020 83	0.144 338	0.018 04	0.024 06	0.036 08	0.054 13	0.090 21	0.102 24	0.108 253	0.180 42	0.204 48
5	0.200 000	0.050 00	0.025 00	0.173 205	0.021 65	0.028 87	0.043 30	0.064 95	0.108 25	0.122 69	0.129 904	0.216 51	0.245 37
4½	0.222 222	0.055 56	0.027 78	0.192 450	0.024 06	0.032 08	0.048 11	0.072 17	0.120 28	0.136 32	0.144 338	0.240 56	0.272 64
4	0.250 000	0.062 50	0.031 25	0.216 506	0.027 06	0.036 08	0.054 13	0.081 19	0.135 32	0.153 36	0.162 380	0.270 63	0.306 72
3½	0.285 714	0.071 43	0.035 71	0.247 435	0.030 93	0.041 24	0.061 86	0.092 79	0.154 65	0.175 27	0.185 577	0.309 29	0.350 53
3	0.333 333	0.083 33	0.041 67	0.288 675	0.036 08	0.048 11	0.072 17	0.108 25	0.180 42	0.204 48	0.216 506	0.360 84	0.408 96
2½	0.400 000	0.100 00	0.050 00	0.346 410	0.043 30	0.057 74	0.086 60	0.129 90	0.216 51	0.245 37	0.259 808	0.433 01	0.490 75
2	0.500 000	0.125 00	0.062 50	0.433 012	0.054 12	0.072 17	0.108 26	0.162 38	0.270 64	0.306 72	0.324 760	0.541 26	0.613 44
1½	0.666 667	0.166 67	0.083 33	0.577 350	0.072 17	0.096 23	0.144 34	0.216 51	0.360 85	0.408 95	0.433 013	0.721 69	0.817 91
1	1.000 000	0.250 00	0.125 00	0.866 025	0.108 25	0.144 34	0.216 51	0.324 76	0.541 27	0.613 43	0.649 519	1.082 53	1.226 87

NOTE For application of symbols, see Annex D.

Section 3: Special series (UNS)

12 Diameter/pitch combinations, fractional sizes

12.1 Diameters

Diameters of UNS threads shall be selected in accordance with Table 27.

Table 27 Diameter increments for UNS threads

Diameter range		Diameter increments		
Above	Up to and including	First choice	Second choice	Third choice
in	in	in	in	in
$\frac{7}{32}$	$\frac{5}{8}$	$\frac{1}{16}$ ^{A)}	$\frac{1}{32}$	—
$\frac{5}{8}$	2	$\frac{1}{8}$ ^{A)}	$\frac{1}{16}$	$\frac{1}{32}$
2	6	$\frac{1}{4}$ ^{A)}	$\frac{1}{8}$	$\frac{1}{16}$
6	—	$\frac{1}{2}$	$\frac{1}{4}$	$\frac{1}{8}$

^{A)} These are the increments used in Table 1. Diameters derived from them are only UNS when associated with pitches other than those with which they are associated in Table 1. The remaining increments will always give non-standard diameters which will be UNS when associated with any pitch.

For second choice diameters up to $\frac{5}{8}$ in and for third choice diameters between $\frac{5}{8}$ in and 2 in, where the nominal size is an odd multiple of $\frac{1}{32}$ in, the decimal equivalent of the nominal fractional diameter shall be rounded to four decimal places, either up or down, so that the last figure in the rounded value is even. This rounded value shall be taken as the basic major diameter for determining limits of size.

12.2 Pitches

Pitches shall be selected from Table 1 or, where a pitch coarser than 4 t.p.i. is required, from Table 26.

NOTE 1 Preference should be given to the pitches in the constant pitch series, i.e. 4, 6, 8, 12, 16, 20, 28 and 32 t.p.i. Where a finer pitch is needed 36 t.p.i or 40 t.p.i. may also be used.

NOTE 2 In general, the coarser the pitch chosen the greater will be the resistance to stripping. (See also BS 3580.)

13 Diameter/pitch combinations, decimal sizes

The diameter/pitch combination shall be selected from Table 37 or, if none of the threads specified in Table 37 is suitable, the diameter/pitch combination shall be selected as follows.

- a) Diameters shall be selected as follows.
 - 1) Diameters from 1.4 in to 6.0 in inclusive.
 - First choice: Those diameters shown in Table 37, Column 1.
 - Second choice: Those diameters shown in Table 37, Column 2.
 - Third choice: The sizes in 0.1 in increments not shown in Table 37, Column 2.
 - Fourth choice: Intermediate sizes in increments of 0.05 in.
 - 2) Diameters above 6 in.
 - First choice: Sizes in increments of 0.5 in.
 - Second choice: Sizes in increments of 0.25 in.
 - Third choice: Sizes in increments of 0.1 in.
- b) Pitches shall be selected from Table 1 or, where a pitch coarser than 4 t.p.i. is required, from Table 26.

NOTE 1 Preference should be given to the pitches in the constant pitch series, i.e. 4, 6, 8, 12, 16, 20, 28 and 32 t.p.i. Where a finer pitch is needed 36 t.p.i or 40 t.p.i. may also be used.

NOTE 2 In general, the coarser the pitch chosen the greater will be the resistance to stripping. (See also BS 3580.)

14 Tolerance classes of external and internal UNS threads

The tolerance classes of external and internal UNS threads shall be in accordance with Clause 6.

15 Tolerances and allowances

The tolerances and allowances for UNS threads shall be in accordance with Table 28 to Table 36 inclusive.

NOTE 1 Guidance on the use of Tables 28 to 36 is given in Annex B.

NOTE 2 The effective diameter tolerances given in Table 30 to Table 35 have been calculated for a length of engagement equal to 9P, and are recommended for use with lengths of engagement from 5P to 15P. If they are considered unsatisfactory for any particular lengths of engagement longer than 15P, or shorter than 5P, the effective diameter tolerance should be calculated from the formulae given in Table A.1, or alternatively derived from the corresponding nomogram given in Figure A.1.

NOTE 3 The tolerances on minor diameters of internal threads may be adjusted in accordance with Clause 7, Note 6.

16 Coated UNS threads

Coated UNS threads shall be in accordance with Clause 9.

17 Designation of UNS threads

UNS threads shall be designated in accordance with Clause 11.

The designation of UNS threads shall include the basic designation as specified in 11.1 and the limits of size.

EXAMPLES, GENERAL

$\frac{1}{4}$ — 24 UNS — 3A
 MAJOR DIA. .2500 — .2428
 EFF. DIA. .2229 — .2201

$1\frac{3}{32}$ — 24 UNS — 3A
 MAJOR DIA. .4062 — .3990
 EFF. DIA. .3791 — .3762

1.20 — 10 UNS — 2B
 MAJOR DIA. 1.091 7 — 1.112 7
 EFF. DIA. 1.135 0 — 1.143 2

EXAMPLE, THREAD WITH SPECIAL LENGTH OF ENGAGEMENT

$4\frac{1}{2}$ — 4 UNS — SE 1A
 MAJOR DIA. 4.4968 — 4.4611
 EFF. DIA. 4.3344 — 4.3198
 LE .75

EXAMPLE, THREAD WITH MODIFIED CRESTS

$1\frac{1}{2}$ — 10 UNS — 3B MOD
 MINOR DIA. 1.3917 — 1.4007 MOD
 EFF. DIA. 1.4350 — 1.4412
 LE .50

NOTE Diameters in decimal units selected in accordance with Clause 13a) need not be expressed to more than two places of decimals.

Table 28 Allowances for external threads of special diameter/pitch combinations (UNS threads) Classes 1A and 2A

1	2	3	4	5	6	7	8	9	10	11	12	13	14	15	16	17	18	19	20	
Threads per inch	Major diameter																			
	Above	$\frac{7}{32}$	$\frac{5}{16}$	$\frac{7}{16}$	$\frac{9}{16}$	$\frac{11}{16}$	$\frac{7}{8}$	$1\frac{1}{8}$	$1\frac{3}{8}$	$1\frac{5}{8}$	$1\frac{7}{8}$	$2\frac{1}{4}$	$2\frac{3}{4}$	$3\frac{1}{4}$	$3\frac{3}{4}$	$4\frac{1}{2}$	$5\frac{1}{2}$	7	9	11
	Up to and including	$\frac{5}{16}$	$\frac{7}{16}$	$\frac{9}{16}$	$\frac{11}{16}$	$\frac{7}{8}$	$1\frac{1}{8}$	$1\frac{3}{8}$	$1\frac{5}{8}$	$1\frac{7}{8}$	$2\frac{1}{4}$	$2\frac{3}{4}$	$3\frac{1}{4}$	$3\frac{3}{4}$	$4\frac{1}{2}$	$5\frac{1}{2}$	7	9	11	13
Allowances																				
	in	in	in	in	in	in	in	in	in	in	in	in	in	in	in	in	in	in	in	in
40	0.000 9	0.000 9	0.001 0	0.001 0	0.001 0	0.001 0	—	—	—	—	—	—	—	—	—	—	—	—	—	—
36	0.000 9	0.001 0	0.001 0	0.001 0	0.001 0	0.001 1	0.001 1	0.001 2	—	—	—	—	—	—	—	—	—	—	—	—
32	0.001 0	0.001 0	0.001 0	0.001 1	0.001 1	0.001 1	0.001 2	0.001 2	0.001 2	0.001 3	0.001 3	0.001 3	—	—	—	—	—	—	—	—
28	0.001 0	0.001 1	0.001 1	0.001 1	0.001 2	0.001 2	0.001 2	0.001 3	0.001 3	0.001 3	0.001 4	0.001 4	0.001 4	0.001 5	—	—	—	—	—	—
24	0.001 1	0.001 1	0.001 2	0.001 2	0.001 2	0.001 3	0.001 3	0.001 3	0.001 4	0.001 4	0.001 4	0.001 5	0.001 5	0.001 5	0.001 6	0.001 6	0.001 6	—	—	—
20	0.001 2	0.001 2	0.001 3	0.001 3	0.001 3	0.001 4	0.001 4	0.001 4	0.001 5	0.001 5	0.001 5	0.001 6	0.001 6	0.001 6	0.001 7	0.001 7	0.001 7	—	—	—
18	—	0.001 3	0.001 3	0.001 4	0.001 4	0.001 4	0.001 5	0.001 5	0.001 5	0.001 5	0.001 6	0.001 6	0.001 7	0.001 7	0.001 7	0.001 8	0.001 9	—	—	—
16	—	0.001 4	0.001 4	0.001 4	0.001 5	0.001 5	0.001 5	0.001 6	0.001 6	0.001 6	0.001 7	0.001 7	0.001 7	0.001 8	0.001 8	0.001 9	0.001 9	0.002 0	—	—
14	—	—	0.001 5	0.001 5	0.001 5	0.001 6	0.001 6	0.001 7	0.001 7	0.001 7	0.001 7	0.001 8	0.001 8	0.001 8	0.001 9	0.002 0	0.002 0	0.002 0	0.002 1	0.002 2
12	—	—	0.001 6	0.001 6	0.001 7	0.001 7	0.001 7	0.001 8	0.001 8	0.001 8	0.001 9	0.001 9	0.001 9	0.002 0	0.002 0	0.002 1	0.002 1	0.002 2	0.002 3	0.002 4
10	—	—	—	—	0.001 8	0.001 8	0.001 9	0.001 9	0.001 9	0.002 0	0.002 0	0.002 0	0.002 1	0.002 1	0.002 2	0.002 2	0.002 3	0.002 4	0.002 4	0.002 5
8	—	—	—	—	—	0.002 1	0.002 1	0.002 1	0.002 1	0.002 2	0.002 2	0.002 3	0.002 3	0.002 3	0.002 4	0.002 4	0.002 5	0.002 6	0.002 6	0.002 6
6	—	—	—	—	—	—	—	0.002 4	0.002 5	0.002 5	0.002 5	0.002 6	0.002 6	0.002 6	0.002 7	0.002 7	0.002 8	0.002 9	0.002 9	0.002 9
4	—	—	—	—	—	—	—	—	—	0.003 0	0.003 1	0.003 1	0.003 1	0.003 2	0.003 2	0.003 3	0.003 4	0.003 4	0.003 5	0.003 5

Table 29 Major diameter tolerances for external threads of special diameter/pitch combinations (UNS threads)

Threads per inch	Major diameter tolerance	
	Class 1A	Classes 2A and 3A
	$0.090 \sqrt[3]{P^2}$	$0.060 \sqrt[3]{P^2}$
40	0.007 7	0.005 1
36	0.008 3	0.005 5
32	0.008 9	0.006 0
28	0.009 8	0.006 5
24	0.010 8	0.007 2
20	0.012 2	0.008 1
18	0.013 1	0.008 7
16	0.014 2	0.009 4
14	0.015 5	0.010 3
12	0.017 2	0.011 4
10	0.019 4	0.012 9
8	0.022 5	0.015 0
6	0.027 3	0.018 2
4	0.035 7	0.023 8

NOTE 1 The major diameter tolerances for external threads are independent of the diameter of the thread.

NOTE 2 These tolerances have also been used in compiling the limits for major diameters of standard external threads given in Table 2.

Table 30 Effective and minor diameter tolerances for external threads of special diameter/pitch combinations (UNS threads) Class 1A

1	2	3	4	5	6	7	8	9	10	11	12	13	14	15	16	17	18	19	20	21	22	
Threads per inch	Length of engagement 5 to 15 pitches	Major diameter																				
		Above	$\frac{7}{32}$	$\frac{5}{16}$	$\frac{7}{16}$	$\frac{9}{16}$	$\frac{11}{16}$	$\frac{7}{8}$	$1\frac{1}{8}$	$1\frac{3}{8}$	$1\frac{5}{8}$	$1\frac{7}{8}$	$2\frac{1}{4}$	$2\frac{3}{4}$	$3\frac{1}{4}$	$3\frac{3}{4}$	$4\frac{1}{2}$	$5\frac{1}{2}$	7	9	11	Extra tolerance on minor diameter ^{A)}
		Up to and including	$\frac{5}{16}$	$\frac{7}{16}$	$\frac{9}{16}$	$\frac{11}{16}$	$\frac{7}{8}$	$1\frac{1}{8}$	$1\frac{3}{8}$	$1\frac{5}{8}$	$1\frac{7}{8}$	$2\frac{1}{4}$	$2\frac{3}{4}$	$3\frac{1}{4}$	$3\frac{3}{4}$	$4\frac{1}{2}$	$5\frac{1}{2}$	7	9	11	13	
Tolerance on effective diameter																						
	in	in	in	in	in	in	in	in	in	in	in	in	in	in	in	in	in	in	in	in	in	in
40	0.12 to 0.38	0.004 4	0.004 6	0.004 8	0.004 9	0.005 0	0.005 2	—	—	—	—	—	—	—	—	—	—	—	—	—	—	0.001 8
36	0.14 to 0.42	0.004 6	0.004 8	0.005 0	0.005 1	0.005 2	0.005 4	0.005 6	0.005 8	—	—	—	—	—	—	—	—	—	—	—	—	0.002 0
32	0.16 to 0.47	0.004 8	0.005 0	0.005 2	0.005 3	0.005 5	0.005 7	0.005 8	0.006 0	0.006 1	0.006 3	0.006 5	0.006 7	—	—	—	—	—	—	—	—	0.002 3
28	0.18 to 0.54	0.005 1	0.005 3	0.005 5	0.005 6	0.005 8	0.006 0	0.006 1	0.006 3	0.006 4	0.006 6	0.006 8	0.007 0	0.007 1	0.007 3	—	—	—	—	—	—	0.002 6
24	0.21 to 0.62	0.005 5	0.005 7	0.005 9	0.006 0	0.006 1	0.006 3	0.006 5	0.006 7	0.006 8	0.006 9	0.007 1	0.007 3	0.007 5	0.007 7	0.007 9	0.008 2	—	—	—	—	0.003 0
20	0.25 to 0.75	0.006 0	0.006 2	0.006 3	0.006 5	0.006 6	0.006 8	0.007 0	0.007 1	0.007 3	0.007 4	0.007 6	0.007 8	0.008 0	0.008 1	0.008 4	0.008 7	—	—	—	—	0.003 6
18	0.28 to 0.83	—	0.006 5	0.006 7	0.006 8	0.006 9	0.007 1	0.007 3	0.007 4	0.007 6	0.007 7	0.007 9	0.008 1	0.008 3	0.008 4	0.008 7	0.009 0	0.009 4	—	—	—	0.004 0
16	0.31 to 0.94	—	0.006 9	0.007 0	0.007 2	0.007 3	0.007 5	0.007 7	0.007 8	0.007 9	0.008 1	0.008 3	0.008 5	0.008 6	0.008 8	0.009 1	0.009 3	0.009 7	0.010 1	—	—	0.004 5
14	0.36 to 1.07	—	—	0.007 5	0.007 6	0.007 7	0.007 9	0.008 1	0.008 3	0.008 4	0.008 5	0.008 7	0.008 9	0.009 1	0.009 2	0.009 5	0.009 8	0.010 2	0.010 5	0.010 8	—	0.005 2
12	0.42 to 1.25	—	—	0.008 0	0.008 2	0.008 3	0.008 5	0.008 7	0.008 8	0.009 0	0.009 1	0.009 3	0.009 5	0.009 7	0.009 8	0.010 1	0.010 3	0.010 7	0.011 1	0.011 4	—	0.006 0
10	0.50 to 1.50	—	—	—	—	0.009 0	0.009 2	0.009 4	0.009 6	0.009 7	0.009 8	0.010 0	0.010 2	0.010 4	0.010 6	0.010 8	0.011 1	0.011 5	0.011 8	0.012 1	—	0.007 2
8	0.62 to 1.88	—	—	—	—	—	0.010 3	0.010 4	0.010 6	0.010 7	0.010 8	0.011 1	0.011 3	0.011 4	0.011 6	0.011 9	0.012 1	0.012 5	0.012 9	0.013 2	—	0.009 0
6	0.83 to 2.50	—	—	—	—	—	—	—	0.012 1	0.012 3	0.012 4	0.012 6	0.012 8	0.013 0	0.013 1	0.013 4	0.013 7	0.014 1	0.014 4	0.014 7	—	0.012 0
4	1.25 to 3.75	—	—	—	—	—	—	—	—	—	0.015 1	0.015 4	0.015 5	0.015 7	0.015 9	0.016 2	0.016 4	0.016 8	0.017 2	0.017 5	—	0.018 0

NOTE 1 The effective diameter tolerances given in the table are suitable for lengths of engagement within the ranges set out in Column 2. For other lengths of engagement the tolerances should be calculated from the formulae given in Table A.1 or by use of the nomogram given in Figure A.1.

NOTE 2 These values do not agree with, and are not to be used in place of, any tabulated values for the UNC, UNF, 4 UN, 6 UN, and 8 UN thread series in Table 2 to Table 14.

A) The tolerance on the minor diameter is obtained by adding the value in Column 22 to the tolerance on the effective diameter.

Table 31 Effective and minor diameter tolerances for external threads of special diameter/pitch combinations (UNS threads) Class 2A

1	2	3	4	5	6	7	8	9	10	11	12	13	14	15	16	17	18	19	20	21	22	
Threads per inch	Length of engagement 5 to 15 pitches	Major diameter																				Extra tolerance on minor diameter ^{A)}
		Above	$\frac{7}{32}$	$\frac{5}{16}$	$\frac{7}{16}$	$\frac{9}{16}$	$\frac{11}{16}$	$\frac{7}{8}$	$1\frac{1}{8}$	$1\frac{3}{8}$	$1\frac{5}{8}$	$1\frac{7}{8}$	$2\frac{1}{4}$	$2\frac{3}{4}$	$3\frac{1}{4}$	$3\frac{3}{4}$	$4\frac{1}{2}$	$5\frac{1}{2}$	7	9	11	
		Up to and including	$\frac{5}{16}$	$\frac{7}{16}$	$\frac{9}{16}$	$\frac{11}{16}$	$\frac{7}{8}$	$1\frac{1}{8}$	$1\frac{3}{8}$	$1\frac{5}{8}$	$1\frac{7}{8}$	$2\frac{1}{4}$	$2\frac{3}{4}$	$3\frac{1}{4}$	$3\frac{3}{4}$	$4\frac{1}{2}$	$5\frac{1}{2}$	7	9	11	13	
Tolerance on effective diameter																						
	in	in	in	in	in	in	in	in	in	in	in	in	in	in	in	in	in	in	in	in	in	
40	0.12 to 0.38	0.002 9	0.003 1	0.003 2	0.003 3	0.003 4	0.003 5	—	—	—	—	—	—	—	—	—	—	—	—	—	0.001 8	
38	0.14 to 0.42	0.003 1	0.003 2	0.003 3	0.003 4	0.003 5	0.003 6	0.003 7	0.003 8	—	—	—	—	—	—	—	—	—	—	—	0.002 0	
32	0.16 to 0.47	0.003 2	0.003 4	0.003 5	0.003 6	0.003 6	0.003 8	0.003 9	0.004 0	0.004 1	0.004 2	0.004 3	0.004 4	—	—	—	—	—	—	—	0.002 3	
28	0.18 to 0.54	0.003 4	0.003 6	0.003 7	0.003 8	0.003 8	0.004 0	0.004 1	0.004 2	0.004 3	0.004 4	0.004 5	0.004 6	0.004 8	0.004 9	—	—	—	—	—	0.002 6	
24	0.21 to 0.62	0.003 7	0.003 8	0.003 9	0.004 0	0.004 1	0.004 2	0.004 3	0.004 4	0.004 5	0.004 6	0.004 8	0.004 9	0.005 0	0.005 1	0.005 3	0.005 4	—	—	—	0.003 0	
20	0.25 to 0.75	0.004 0	0.004 1	0.004 2	0.004 3	0.004 4	0.004 5	0.004 7	0.004 8	0.004 8	0.004 9	0.005 1	0.005 2	0.005 3	0.005 4	0.005 6	0.005 8	—	—	—	0.003 6	
18	0.28 to 0.83	—	0.004 3	0.004 4	0.004 5	0.004 6	0.004 7	0.004 9	0.005 0	0.005 1	0.005 1	0.005 3	0.005 4	0.005 5	0.005 6	0.005 8	0.006 0	0.006 2	—	—	0.004 0	
16	0.31 to 0.94	—	0.004 6	0.004 7	0.004 8	0.004 9	0.005 0	0.005 1	0.005 2	0.005 3	0.005 4	0.005 5	0.005 7	0.005 8	0.005 9	0.006 1	0.006 2	0.006 5	0.006 7	—	0.004 5	
14	0.36 to 1.07	—	—	0.005 0	0.005 1	0.005 1	0.005 3	0.005 4	0.005 5	0.005 6	0.005 7	0.005 8	0.005 9	0.006 1	0.006 2	0.006 3	0.006 5	0.006 8	0.007 0	0.007 2	0.005 2	
12	0.42 to 1.25	—	—	0.005 4	0.005 4	0.005 5	0.005 7	0.005 8	0.005 9	0.006 0	0.006 1	0.006 2	0.006 3	0.006 4	0.006 5	0.006 7	0.006 9	0.007 2	0.007 4	0.007 6	0.006 0	
10	0.50 to 1.50	—	—	—	—	0.006 0	0.006 2	0.006 3	0.006 4	0.006 5	0.006 5	0.006 7	0.006 8	0.006 9	0.007 0	0.007 2	0.007 4	0.007 7	0.007 9	0.008 1	0.007 2	
8	0.62 to 1.88	—	—	—	—	—	0.006 8	0.007 0	0.007 1	0.007 1	0.007 2	0.007 4	0.007 5	0.007 6	0.007 7	0.007 9	0.008 1	0.008 3	0.008 6	0.008 8	0.009 0	
6	0.83 to 2.50	—	—	—	—	—	—	—	0.008 1	0.008 2	0.008 3	0.008 4	0.008 5	0.008 7	0.008 8	0.008 9	0.009 1	0.009 4	0.009 6	0.009 8	0.012 0	
4	1.25 to 3.75	—	—	—	—	—	—	—	—	—	0.010 1	0.010 2	0.010 4	0.010 5	0.010 6	0.010 8	0.010 9	0.011 2	0.011 4	0.011 6	0.018 0	

NOTE 1 The effective diameter tolerances given in the table are suitable for lengths of engagement within the ranges set out in Column 2. For other lengths of engagement the tolerances should be calculated from the formulae given in Table A.1 or by use of the nomogram given in Figure A.1.

NOTE 2 These values do not agree with, and are not to be used in place of, any tabulated values for the UNC, UNF, 4 UN, 6 UN, and 8 UN thread series in Table 2 to Table 14.

A) The tolerance on the minor diameter is obtained by adding the value in Column 22 to the tolerance on the effective diameter.

Table 32 Effective and minor diameter tolerances for external threads of special diameter/pitch combinations (UNS threads) Class 3A

1	2	3	4	5	6	7	8	9	10	11	12	13	14	15	16	17	18	19	20	21	22	
Threads per inch	Length of engagement 5 to 15 pitches	Major diameter																				Extra tolerance on minor diameter ^{A)}
		Above $\frac{7}{32}$	$\frac{5}{16}$	$\frac{7}{16}$	$\frac{9}{16}$	$\frac{11}{16}$	$\frac{7}{8}$	$1\frac{1}{8}$	$1\frac{3}{8}$	$1\frac{5}{8}$	$1\frac{7}{8}$	$2\frac{1}{4}$	$2\frac{3}{4}$	$3\frac{1}{4}$	$3\frac{3}{4}$	$4\frac{1}{2}$	$5\frac{1}{2}$	7	9	11		
		Up to and including $\frac{5}{16}$	$\frac{7}{16}$	$\frac{9}{16}$	$\frac{11}{16}$	$\frac{7}{8}$	$1\frac{1}{8}$	$1\frac{3}{8}$	$1\frac{5}{8}$	$1\frac{7}{8}$	$2\frac{1}{4}$	$2\frac{3}{4}$	$3\frac{1}{4}$	$3\frac{3}{4}$	$4\frac{1}{2}$	$5\frac{1}{2}$	7	9	11	13		
Tolerance on effective diameter																						
	in	in	in	in	in	in	in	in	in	in	in	in	in	in	in	in	in	in	in	in	in	
40	0.12 to 0.38	0.002 2	0.002 3	0.002 4	0.002 5	0.002 5	0.002 6	—	—	—	—	—	—	—	—	—	—	—	—	—	0.001 8	
36	0.14 to 0.42	0.002 3	0.002 4	0.002 5	0.002 6	0.002 6	0.002 7	0.002 8	0.002 9	—	—	—	—	—	—	—	—	—	—	—	0.002 0	
32	0.16 to 0.47	0.002 4	0.002 5	0.002 6	0.002 7	0.002 7	0.002 8	0.002 9	0.003 0	0.003 1	0.003 1	0.003 2	0.003 3	0.003 4	0.003 5	0.003 6	0.003 6	—	—	—	0.002 3	
28	0.18 to 0.54	0.002 6	0.002 7	0.002 8	0.002 8	0.002 9	0.003 0	0.003 1	0.003 1	0.003 2	0.003 3	0.003 4	0.003 5	0.003 6	0.003 6	—	—	—	—	—	0.002 6	
24	0.21 to 0.62	0.002 8	0.002 9	0.002 9	0.003 0	0.003 1	0.003 2	0.003 3	0.003 3	0.003 4	0.003 5	0.003 6	0.003 7	0.003 7	0.003 8	0.004 0	0.004 1	—	—	—	0.003 0	
20	0.25 to 0.75	0.003 0	0.003 1	0.003 2	0.003 2	0.003 3	0.003 4	0.003 5	0.003 6	0.003 6	0.003 7	0.003 8	0.003 9	0.004 0	0.004 1	0.004 2	0.004 3	—	—	—	0.003 6	
18	0.28 to 0.83	—	0.003 2	0.003 3	0.003 4	0.003 5	0.003 6	0.003 6	0.003 7	0.003 8	0.003 9	0.004 0	0.004 1	0.004 1	0.004 2	0.004 4	0.004 5	0.004 7	—	—	0.004 0	
16	0.31 to 0.94	—	0.003 4	0.003 5	0.003 6	0.003 6	0.003 7	0.003 8	0.003 9	0.004 0	0.004 0	0.004 1	0.004 2	0.004 3	0.004 4	0.004 5	0.004 7	0.004 9	0.005 0	—	0.004 5	
14	0.36 to 1.07	—	—	0.003 7	0.003 8	0.003 9	0.004 0	0.004 1	0.004 1	0.004 2	0.004 3	0.004 4	0.004 5	0.004 5	0.004 6	0.004 8	0.004 9	0.005 1	0.005 3	0.005 4	0.005 2	
12	0.42 to 1.25	—	—	0.004 0	0.004 1	0.004 1	0.004 2	0.004 3	0.004 4	0.004 5	0.004 5	0.004 6	0.004 7	0.004 8	0.004 9	0.005 0	0.005 2	0.005 4	0.005 5	0.005 7	0.006 0	
10	0.50 to 1.50	—	—	—	—	0.004 5	0.004 6	0.004 7	0.004 8	0.004 8	0.004 9	0.005 0	0.005 1	0.005 2	0.005 3	0.005 4	0.005 5	0.005 7	0.005 9	0.006 1	0.007 2	
8	0.62 to 1.88	—	—	—	—	—	0.005 1	0.005 2	0.005 3	0.005 4	0.005 4	0.005 5	0.005 6	0.005 7	0.005 8	0.005 9	0.006 1	0.006 3	0.006 4	0.006 6	0.009 0	
6	0.83 to 2.50	—	—	—	—	—	—	—	0.006 1	0.006 1	0.006 2	0.006 3	0.006 4	0.006 5	0.006 6	0.006 7	0.006 8	0.007 0	0.007 2	0.007 4	0.012 0	
4	1.25 to 3.75	—	—	—	—	—	—	—	—	—	0.007 6	0.007 7	0.007 8	0.007 9	0.007 9	0.008 1	0.008 2	0.008 4	0.008 6	0.008 7	0.018 0	

NOTE 1 The effective diameter tolerances given in the table are suitable for lengths of engagement within the ranges set out in Column 2. For other lengths of engagement the tolerances should be calculated from the three-part formulae given in Table A.1 or by use of the nomogram given in Figure A.1.

NOTE 2 These values do not agree with, and are not to be used in place of, any tabulated values for the UNC, UNF, 4 UN, 6 UN, and 8 UN thread series in Table 2 to Table 14.

A) The tolerance on the minor diameter is obtained by adding the value in Column 22 to the tolerance on the effective diameter.

Table 33 Effective diameter tolerances for internal threads of special diameter/pitch combinations (UNS threads) Class 1B

1	2	3	4	5	6	7	8	9	10	11	12	13	14	15	16	17	18	19	20	21	
Threads per inch	Length of engagement 5 to 15 pitches	Major diameter																			
		Above	$\frac{7}{32}$	$\frac{5}{16}$	$\frac{7}{16}$	$\frac{9}{16}$	$\frac{11}{16}$	$\frac{7}{8}$	$1\frac{1}{8}$	$1\frac{3}{8}$	$1\frac{5}{8}$	$1\frac{7}{8}$	$2\frac{1}{4}$	$2\frac{3}{4}$	$3\frac{1}{4}$	$3\frac{3}{4}$	$4\frac{1}{2}$	$5\frac{1}{2}$	7	9	11
		Up to and including	$\frac{5}{16}$	$\frac{7}{16}$	$\frac{9}{16}$	$\frac{11}{16}$	$\frac{7}{8}$	$1\frac{1}{8}$	$1\frac{3}{8}$	$1\frac{5}{8}$	$1\frac{7}{8}$	$2\frac{1}{4}$	$2\frac{3}{4}$	$3\frac{1}{4}$	$3\frac{3}{4}$	$4\frac{1}{2}$	$5\frac{1}{2}$	7	9	11	13
		Tolerance on effective diameter																			
	in	in	in	in	in	in	in	in	in	in	in	in	in	in	in	in	in	in	in	in	in
40	0.12 to 0.38	0.005 7	0.006 0	0.006 2	0.006 4	0.006 5	0.006 8	—	—	—	—	—	—	—	—	—	—	—	—	—	—
36	0.14 to 0.42	0.006 0	0.006 3	0.006 5	0.006 6	0.006 8	0.007 1	0.007 3	0.007 5	—	—	—	—	—	—	—	—	—	—	—	—
32	0.16 to 0.47	0.006 5	0.006 6	0.006 8	0.007 0	0.007 1	0.007 4	0.007 6	0.007 8	0.008 0	0.008 1	0.008 4	0.008 7	—	—	—	—	—	—	—	—
28	0.18 to 0.54	0.006 7	0.006 9	0.007 2	0.007 3	0.007 5	0.007 8	0.008 0	0.008 2	0.008 4	0.008 5	0.008 8	0.009 0	0.009 3	0.009 5	—	—	—	—	—	—
24	0.21 to 0.62	0.007 2	0.007 4	0.007 6	0.007 8	0.008 0	0.008 2	0.008 5	0.008 7	0.008 8	0.009 0	0.009 3	0.009 5	0.009 7	0.010 0	0.010 3	0.010 6	—	—	—	—
20	0.25 to 0.75	0.007 8	0.008 0	0.008 3	0.008 4	0.008 6	0.008 9	0.009 1	0.009 3	0.009 5	0.009 6	0.009 9	0.010 1	0.010 4	0.010 6	0.010 9	0.011 2	—	—	—	—
18	0.28 to 0.83	—	0.008 4	0.008 7	0.008 8	0.009 0	0.009 3	0.009 5	0.009 7	0.009 9	0.010 0	0.010 3	0.010 5	0.010 8	0.011 0	0.011 3	0.011 6	0.012 2	—	—	—
16	0.31 to 0.94	—	0.008 9	0.009 1	0.009 3	0.009 5	0.009 7	0.010 0	0.010 1	0.010 3	0.010 5	0.010 8	0.011 0	0.011 2	0.011 4	0.011 8	0.012 1	0.012 6	0.013 1	—	—
14	0.36 to 1.07	—	—	0.009 7	0.009 9	0.010 0	0.010 3	0.010 5	0.010 7	0.010 9	0.011 1	0.011 4	0.011 6	0.011 8	0.012 0	0.012 4	0.012 7	0.013 2	0.013 7	0.014 1	—
12	0.42 to 1.25	—	—	0.010 4	0.010 6	0.010 8	0.011 0	0.011 3	0.011 5	0.011 6	0.011 8	0.012 1	0.012 3	0.012 6	0.012 8	0.013 1	0.013 4	0.014 0	0.014 4	0.014 8	—
10	0.50 to 1.50	—	—	—	—	0.011 7	0.012 0	0.012 2	0.012 4	0.012 6	0.012 8	0.013 0	0.013 3	0.013 5	0.013 7	0.014 1	0.014 4	0.014 9	0.015 4	0.015 8	—
8	0.62 to 1.88	—	—	—	—	—	0.013 3	0.013 6	0.013 8	0.013 9	0.014 1	0.014 4	0.014 6	0.014 9	0.015 1	0.015 4	0.015 7	0.016 3	0.016 7	0.017 1	—
6	0.85 to 2.50	—	—	—	—	—	—	—	0.015 8	0.016 0	0.016 1	0.016 4	0.016 7	0.016 9	0.017 1	0.017 4	0.017 8	0.018 3	0.018 7	0.019 1	—
4	1.25 to 3.75	—	—	—	—	—	—	—	—	—	0.019 7	0.020 0	0.020 2	0.020 4	0.020 6	0.021 0	0.021 3	0.021 8	0.022 3	0.022 7	—

NOTE 1 The effective diameter tolerances given in the table are suitable for lengths of engagement within the ranges set out in Column 2. For other lengths of engagement the tolerances should be calculated from the formulae given in Table A.1 or by use of the nomogram given in Figure A.1.

NOTE 2 These values do not agree with and are not to be used in place of any tabulated values for the UNC, UNF, 4 UN, 6 UN, and 8 UN thread series in Table 2 to Table 14.

Table 34 Effective diameter tolerances for internal threads of special diameter/pitch combinations (UNS threads) Class 2B

1	2	3	4	5	6	7	8	9	10	11	12	13	14	15	16	17	18	19	20	21	
Threads per inch	Length of engagement 5 to 15 pitches	Major diameter																			
		Above	$\frac{7}{32}$	$\frac{5}{16}$	$\frac{7}{16}$	$\frac{9}{16}$	$\frac{11}{16}$	$\frac{7}{8}$	$1\frac{1}{8}$	$1\frac{3}{8}$	$1\frac{5}{8}$	$1\frac{7}{8}$	$2\frac{1}{4}$	$2\frac{3}{4}$	$3\frac{1}{4}$	$3\frac{3}{4}$	$4\frac{1}{2}$	$5\frac{1}{2}$	7	9	11
		Up to and including	$\frac{5}{16}$	$\frac{7}{16}$	$\frac{9}{16}$	$\frac{11}{16}$	$\frac{7}{8}$	$1\frac{1}{8}$	$1\frac{3}{8}$	$1\frac{5}{8}$	$1\frac{7}{8}$	$2\frac{1}{4}$	$2\frac{3}{4}$	$3\frac{1}{4}$	$3\frac{3}{4}$	$4\frac{1}{2}$	$5\frac{1}{2}$	7	9	11	13
		Tolerance on effective diameter																			
	in	in	in	in	in	in	in	in	in	in	in	in	in	in	in	in	in	in	in	in	
40	0.12 to 0.38	0.003 8	0.004 0	0.004 1	0.004 3	0.004 4	0.004 5	—	—	—	—	—	—	—	—	—	—	—	—	—	
36	0.14 to 0.42	0.004 0	0.004 2	0.004 3	0.004 4	0.004 5	0.004 7	0.004 9	0.005 0	—	—	—	—	—	—	—	—	—	—	—	
32	0.16 to 0.47	0.004 2	0.004 4	0.004 5	0.004 6	0.004 7	0.004 9	0.005 1	0.005 2	0.005 3	0.005 4	0.005 6	0.005 8	—	—	—	—	—	—	—	
28	0.18 to 0.54	0.004 4	0.004 6	0.004 8	0.004 9	0.005 0	0.005 2	0.005 3	0.005 5	0.005 6	0.005 7	0.005 9	0.006 0	0.006 2	0.006 3	—	—	—	—	—	
24	0.21 to 0.62	0.004 8	0.004 9	0.005 1	0.005 2	0.005 3	0.005 5	0.005 6	0.005 8	0.005 9	0.006 0	0.006 2	0.006 4	0.006 5	0.006 6	0.006 9	0.007 1	—	—	—	
20	0.25 to 0.75	0.005 2	0.005 4	0.005 5	0.005 6	0.005 7	0.005 9	0.006 1	0.006 2	0.006 3	0.006 4	0.006 6	0.006 8	0.006 9	0.007 0	0.007 3	0.007 5	—	—	—	
18	0.28 to 0.83	—	0.005 6	0.005 8	0.005 9	0.006 0	0.006 2	0.006 3	0.006 5	0.006 6	0.006 7	0.006 9	0.007 0	0.007 2	0.007 3	0.007 6	0.007 8	0.008 1	—	—	
16	0.31 to 0.94	—	0.005 9	0.006 1	0.006 2	0.006 3	0.006 5	0.006 6	0.006 8	0.006 9	0.007 0	0.007 2	0.007 3	0.007 5	0.007 6	0.007 9	0.008 1	0.008 4	0.008 7	—	
14	0.36 to 1.07	—	—	0.006 5	0.006 6	0.006 7	0.006 9	0.007 0	0.007 2	0.007 3	0.007 4	0.007 6	0.007 7	0.007 9	0.008 0	0.008 3	0.008 5	0.008 8	0.009 1	0.009 4	
12	0.42 to 1.25	—	—	0.007 0	0.007 1	0.007 2	0.007 4	0.007 5	0.007 6	0.007 8	0.007 9	0.008 1	0.008 2	0.008 4	0.008 5	0.008 7	0.009 0	0.009 3	0.009 6	0.009 9	
10	0.50 to 1.50	—	—	—	—	0.007 8	0.008 0	0.008 2	0.008 3	0.008 4	0.008 5	0.008 7	0.008 9	0.009 0	0.009 1	0.009 4	0.009 6	0.010 0	0.010 3	0.010 5	
8	0.62 to 1.88	—	—	—	—	—	0.008 9	0.009 0	0.009 2	0.009 3	0.009 4	0.009 6	0.009 8	0.009 9	0.010 0	0.010 3	0.010 5	0.010 8	0.011 1	0.011 4	
6	0.83 to 2.50	—	—	—	—	—	—	—	0.010 5	0.010 6	0.010 8	0.010 9	0.011 1	0.011 3	0.011 4	0.011 6	0.011 8	0.012 2	0.012 5	0.012 8	
4	1.25 to 3.75	—	—	—	—	—	—	—	—	—	0.013 1	0.013 3	0.013 5	0.013 6	0.013 8	0.014 0	0.014 2	0.014 6	0.014 9	0.015 1	

NOTE 1 The effective diameter tolerances given in the table are suitable for lengths of engagement within the ranges set out in Column 2. For other lengths of engagement the tolerances should be calculated from the formulae given in Table A.1 or by use of the nomogram given in Figure A.1.

NOTE 2 These values do not agree with, and are not to be used in place of, any tabulated values for the UNC, UNF, 4 UN, 6 UN, and 8 UN thread series, in Table 2 to Table 14.

Table 35 Effective diameter tolerances for internal threads of special diameter/pitch combinations (UNS threads) Class 3B

1	2	3	4	5	6	7	8	9	10	11	12	13	14	15	16	17	18	19	20	21	
Threads per inch	Length of engagement 5 to 15 pitches	Major diameter																			
		Above	$\frac{7}{32}$	$\frac{5}{16}$	$\frac{7}{16}$	$\frac{9}{16}$	$\frac{11}{16}$	$\frac{7}{8}$	$1\frac{1}{8}$	$1\frac{3}{8}$	$1\frac{5}{8}$	$1\frac{7}{8}$	$2\frac{1}{4}$	$2\frac{3}{4}$	$3\frac{1}{4}$	$3\frac{3}{4}$	$4\frac{1}{2}$	$5\frac{1}{2}$	7	9	11
		Up to and including	$\frac{5}{16}$	$\frac{7}{16}$	$\frac{9}{16}$	$\frac{11}{16}$	$\frac{7}{8}$	$1\frac{1}{8}$	$1\frac{3}{8}$	$1\frac{5}{8}$	$1\frac{7}{8}$	$2\frac{1}{4}$	$2\frac{3}{4}$	$3\frac{1}{4}$	$3\frac{3}{4}$	$4\frac{1}{2}$	$5\frac{1}{2}$	7	9	11	13
		Tolerance on effective diameter																			
	in	in	in	in	in	in	in	in	in	in	in	in	in	in	in	in	in	in	in	in	in
40	0.12 to 0.38	0.002 9	0.003 0	0.003 1	0.003 2	0.003 3	0.003 4	—	—	—	—	—	—	—	—	—	—	—	—	—	—
36	0.14 to 0.42	0.003 0	0.003 1	0.003 2	0.003 3	0.003 4	0.003 5	0.003 6	0.003 7	—	—	—	—	—	—	—	—	—	—	—	—
32	0.16 to 0.47	0.003 1	0.003 3	0.003 4	0.003 5	0.003 6	0.003 7	0.003 8	0.003 9	0.004 0	0.004 1	0.004 2	0.004 3	—	—	—	—	—	—	—	—
28	0.18 to 0.54	0.003 3	0.003 5	0.003 6	0.003 7	0.003 7	0.003 9	0.004 0	0.004 1	0.004 2	0.004 3	0.004 4	0.004 5	0.004 6	0.004 7	—	—	—	—	—	—
24	0.21 to 0.62	0.003 6	0.003 7	0.003 8	0.003 9	0.004 0	0.004 1	0.004 2	0.004 3	0.004 4	0.004 5	0.004 6	0.004 8	0.004 9	0.005 0	0.005 2	0.005 3	—	—	—	—
20	0.25 to 0.75	0.003 9	0.004 0	0.004 1	0.004 2	0.004 3	0.004 4	0.004 5	0.004 6	0.004 7	0.004 8	0.005 0	0.005 1	0.005 2	0.005 3	0.005 5	0.005 6	—	—	—	—
18	0.28 to 0.83	—	0.004 2	0.004 3	0.004 4	0.004 5	0.004 6	0.004 7	0.004 8	0.004 9	0.005 0	0.005 1	0.005 3	0.005 4	0.005 5	0.005 7	0.005 8	0.006 1	—	—	—
16	0.31 to 0.94	—	0.004 5	0.004 6	0.004 7	0.004 7	0.004 9	0.005 0	0.005 1	0.005 2	0.005 2	0.005 4	0.005 5	0.005 6	0.005 7	0.005 9	0.006 1	0.006 3	0.006 6	—	—
14	0.36 to 1.07	—	—	0.004 9	0.004 9	0.005 0	0.005 2	0.005 3	0.005 4	0.005 5	0.005 5	0.005 7	0.005 8	0.005 9	0.006 0	0.006 2	0.006 3	0.006 6	0.006 8	0.007 0	—
12	0.42 to 1.25	—	—	0.005 2	0.005 3	0.005 4	0.005 5	0.005 6	0.005 7	0.005 8	0.005 9	0.006 0	0.006 2	0.006 3	0.006 4	0.006 6	0.006 7	0.007 0	0.007 2	0.007 4	—
10	0.50 to 1.50	—	—	—	—	0.005 9	0.006 0	0.006 1	0.006 2	0.006 3	0.006 4	0.006 5	0.006 6	0.006 8	0.006 9	0.007 0	0.007 2	0.007 5	0.007 7	0.007 9	—
8	0.62 to 1.88	—	—	—	—	—	0.006 7	0.006 8	0.006 9	0.007 0	0.007 1	0.007 2	0.007 3	0.007 4	0.007 5	0.007 7	0.007 9	0.008 1	0.008 4	0.008 6	—
6	0.83 to 2.50	—	—	—	—	—	—	—	0.007 9	0.008 0	0.008 1	0.008 2	0.008 3	0.008 4	0.008 5	0.008 7	0.008 9	0.009 1	0.009 4	0.009 6	—
4	1.25 to 3.75	—	—	—	—	—	—	—	—	—	0.009 8	0.010 0	0.010 1	0.010 2	0.010 3	0.010 5	0.010 7	0.010 9	0.011 1	0.011 3	—

NOTE 1 The effective diameter tolerances given in the table are suitable for lengths of engagement within the ranges set out in Column 2. For other lengths of engagement the tolerances should be calculated from the formulae given in Table A.1 or by use of the nomogram given in Figure A.1.

NOTE 2 These values do not agree with, and are not to be used in place of, any tabulated values for the UNC, UNF, 4 UN, 6 UN, and 8 UN thread series in Table 2 to Table 14.

Table 37 Unified screw threads – Decimal inch diameters with preferred pitches

1	2	3	4	5	6	7	8	9	10	11
Preferred diameters		Preferred pitches (threads per inch)								
First choice in	Second choice in	UNC series	UNF series	4	6	8	12	16	20	28
—	1.4	—	—	—	6 UNS	8 UNS	12 UNS	16 UNS	20 UNS	28 UNS
1.5	—	6	12	—	UNC	8 UN	UNF	16 UN	20 UN	28 UN
—	1.6	—	—	—	6 UNS	8 UNS	12 UNS	16 UNS	20 UNS	—
1.75	—	5	—	—	6 UN	8 UN	12 UN	16 UN	20 UN	—
—	1.9	—	—	—	6 UNS	8 UNS	12 UNS	16 UNS	20 UNS	—
2.0	—	4½	—	—	6 UN	8 UN	12 UN	16 UN	20 UN	—
—	2.1	—	—	—	6 UNS	8 UNS	12 UNS	16 UNS	20 UNS	—
2.25	—	4½	—	—	6 UN	8 UN	12 UN	16 UN	20 UN	—
—	2.4	—	—	—	6 UNS	8 UNS	12 UNS	16 UNS	20 UNS	—
2.5	—	4	—	UNC	6 UN	8 UN	12 UN	16 UN	20 UN	—
—	2.6	—	—	—	6 UNS	8 UNS	12 UNS	16 UNS	20 UNS	—
2.75	—	4	—	UNC	6 UN	8 UN	12 UN	16 UN	20 UN	—
—	2.9	—	—	—	6 UNS	8 UNS	12 UNS	16 UNS	20 UNS	—
3.0	—	4	—	UNC	6 UN	8 UN	12 UN	16 UN	20 UN	—
—	3.1	—	—	—	6 UNS	8 UNS	12 UNS	16 UNS	—	—
3.25	—	4	—	UNC	6 UN	8 UN	12 UN	16 UN	—	—
—	3.4	—	—	—	6 UNS	8 UNS	12 UNS	16 UNS	—	—
3.5	—	4	—	UNC	6 UN	8 UN	12 UN	16 UN	—	—
—	3.6	—	—	—	6 UNS	8 UNS	12 UNS	16 UNS	—	—
3.75	—	4	—	UNC	6 UN	8 UN	12 UN	16 UN	—	—
—	3.9	—	—	—	6 UNS	8 UNS	12 UNS	16 UNS	—	—
4.0	—	4	—	UNC	6 UN	8 UN	12 UN	16 UN	—	—
—	4.1	—	—	—	6 UNS	8 UNS	12 UNS	16 UNS	—	—
4.25	—	—	—	4 UN	6 UN	8 UN	12 UN	16 UN	—	—
—	4.4	—	—	4 UNS	6 UNS	8 UNS	12 UNS	16 UNS	—	—
4.5	—	—	—	4 UN	6 UN	8 UN	12 UN	16 UN	—	—
—	4.6	—	—	4 UNS	6 UNS	8 UNS	12 UNS	16 UNS	—	—
4.75	—	—	—	4 UN	6 UN	8 UN	12 UN	16 UN	—	—
—	4.9	—	—	4 UNS	6 UNS	8 UNS	12 UNS	16 UNS	—	—
5.0	—	—	—	4 UN	6 UN	8 UN	12 UN	16 UN	—	—
—	5.1	—	—	4 UNS	6 UNS	8 UNS	12 UNS	16 UNS	—	—
5.25	—	—	—	4 UN	6 UN	8 UN	12 UN	16 UN	—	—
—	5.4	—	—	4 UNS	6 UNS	8 UNS	12 UNS	16 UNS	—	—
5.5	—	—	—	4 UN	6 UN	8 UN	12 UN	16 UN	—	—
—	5.6	—	—	4 UNS	6 UNS	8 UNS	12 UNS	16 UNS	—	—
5.75	—	—	—	4 UN	6 UN	8 UN	12 UN	16 UN	—	—
—	5.9	—	—	4 UNS	6 UNS	8 UNS	12 UNS	16 UNS	—	—
6.0	—	—	—	4 UN	6 UN	8 UN	12 UN	16 UN	—	—

NOTE For limits of size for UNC, UNF and UN threads given in this table see Table 2 to Table 14. Those for UNS threads are given in Table 38.

Table 38 Limits of size for UNS threads having decimal inch basic sizes and preferred pitches

1	2	3	4	5	6	7	8	9	10	11	12	13	14	15	16	17	18
Nominal size and threads per inch	Series designation	External threads									Internal threads						
		Class	Allowance	Major diameter		Effective diameter			Minor diameter		Class	Minor diameter		Effective diameter			Major diameter
				Max.	Min.	Max.	Min.	Tol.	Max.	Min.		Min.	Max.	Min.	Max.	Tol.	
				in	in	in	in	in	in	in		in	in	in	in	in	
1.4 — 6	UNS	2A	0.002 4	1.397 6	1.379 4	1.289 3	1.281 2	0.008 1	1.193 1	1.173 0	2B	1.219 6	1.250 2	1.291 7	1.302 2	0.010 5	1.400 0
		3A	0.000 0	1.400 0	1.381 8	1.291 7	1.285 6	0.006 1	1.195 5	1.177 4	3B	1.219 6	1.239 6	1.291 7	1.299 6	0.007 9	1.400 0
1.4 — 8	UNS	2A	0.002 1	1.397 9	1.382 9	1.316 7	1.309 6	0.007 1	1.244 5	1.228 4	2B	1.264 7	1.289 7	1.318 8	1.328 0	0.009 2	1.400 0
		3A	0.000 0	1.400 0	1.385 0	1.318 8	1.313 5	0.005 3	1.246 6	1.232 3	3B	1.264 7	1.279 7	1.318 8	1.325 7	0.006 9	1.400 0
1.4 — 12	UNS	2A	0.001 8	1.398 2	1.386 8	1.344 1	1.338 2	0.005 9	1.296 0	1.284 1	2B	1.309 8	1.327 9	1.345 9	1.353 5	0.007 6	1.400 0
		3A	0.000 0	1.400 0	1.388 6	1.345 9	1.341 5	0.004 4	1.297 8	1.287 4	3B	1.309 8	1.319 8	1.345 9	1.351 6	0.005 7	1.400 0
1.4 — 16	UNS	2A	0.001 6	1.398 4	1.389 0	1.357 8	1.352 6	0.005 2	1.321 7	1.312 0	2B	1.332 3	1.346 4	1.359 4	1.366 2	0.006 8	1.400 0
		3A	0.000 0	1.400 0	1.390 6	1.359 4	1.355 5	0.003 9	1.323 3	1.314 9	3B	1.332 3	1.340 8	1.359 4	1.364 5	0.005 1	1.400 0
1.4 — 20	UNS	2A	0.001 4	1.398 6	1.390 5	1.366 1	1.361 3	0.004 8	1.337 3	1.328 9	2B	1.345 9	1.357 4	1.367 5	1.373 7	0.006 2	1.400 0
		3A	0.000 0	1.400 0	1.391 9	1.367 5	1.363 9	0.003 6	1.338 7	1.331 5	3B	1.345 9	1.353 7	1.367 5	1.372 1	0.004 6	1.400 0
1.4 — 28	UNS	2A	0.001 3	1.398 7	1.392 2	1.375 5	1.371 3	0.004 2	1.354 9	1.348 1	2B	1.361 3	1.369 7	1.376 8	1.382 3	0.005 5	1.400 0
		3A	0.000 0	1.400 0	1.393 5	1.376 8	1.373 7	0.003 1	1.356 2	1.350 5	3B	1.361 3	1.367 6	1.376 8	1.380 9	0.004 1	1.400 0
1.6 — 6	UNS	2A	0.002 4	1.597 6	1.579 4	1.489 3	1.481 2	0.008 1	1.393 1	1.373 0	2B	1.419 6	1.450 2	1.491 7	1.502 2	0.010 5	1.600 0
		3A	0.000 0	1.600 0	1.581 8	1.491 7	1.485 6	0.006 1	1.395 5	1.377 4	3B	1.419 6	1.439 6	1.491 7	1.499 6	0.007 9	1.600 0
1.6 — 8	UNS	2A	0.002 1	1.597 9	1.582 9	1.516 7	1.509 6	0.007 1	1.444 5	1.428 4	2B	1.464 7	1.489 7	1.518 8	1.528 0	0.009 2	1.600 0
		3A	0.000 0	1.600 0	1.585 0	1.518 8	1.513 5	0.005 3	1.446 6	1.432 3	3B	1.464 7	1.479 7	1.518 8	1.525 7	0.006 9	1.600 0
1.6 — 12	UNS	2A	0.001 8	1.598 2	1.586 8	1.544 1	1.538 2	0.005 9	1.496 0	1.484 1	2B	1.509 8	1.527 9	1.545 9	1.553 5	0.007 6	1.600 0
		3A	0.000 0	1.600 0	1.588 6	1.545 9	1.541 5	0.004 4	1.497 8	1.487 4	3B	1.509 8	1.519 8	1.545 9	1.551 6	0.005 7	1.600 0
1.6 — 16	UNS	2A	0.001 6	1.598 4	1.589 0	1.557 8	1.552 6	0.005 2	1.521 7	1.512 0	2B	1.532 3	1.546 4	1.559 4	1.566 2	0.006 8	1.600 0
		3A	0.000 0	1.600 0	1.590 6	1.559 4	1.555 5	0.003 9	1.523 3	1.514 9	3B	1.532 3	1.540 8	1.559 4	1.564 5	0.005 1	1.600 0
1.6 — 20	UNS	2A	0.001 4	1.598 6	1.590 5	1.566 1	1.561 3	0.004 8	1.537 3	1.528 9	2B	1.545 9	1.557 4	1.567 5	1.573 7	0.006 2	1.600 0
		3A	0.000 0	1.600 0	1.591 9	1.567 5	1.563 9	0.003 6	1.538 7	1.531 5	3B	1.545 9	1.553 7	1.567 5	1.572 1	0.004 6	1.600 0
1.9 — 6	UNS	2A	0.002 5	1.897 5	1.879 3	1.789 2	1.780 9	0.008 3	1.693 0	1.672 7	2B	1.719 6	1.750 2	1.791 7	1.802 5	0.010 8	1.900 0
		3A	0.000 0	1.900 0	1.881 8	1.791 7	1.785 5	0.006 2	1.695 5	1.677 3	3B	1.719 6	1.739 6	1.791 7	1.799 8	0.008 1	1.900 0
1.9 — 8	UNS	2A	0.002 2	1.897 8	1.882 8	1.816 6	1.809 4	0.007 2	1.744 4	1.728 2	2B	1.764 7	1.789 7	1.818 8	1.828 2	0.009 4	1.900 0
		3A	0.000 0	1.900 0	1.885 0	1.818 8	1.813 4	0.005 4	1.746 6	1.732 2	3B	1.764 7	1.779 7	1.818 8	1.815 9	0.007 1	1.900 0

Table 38 Limits of size for UNS threads having decimal inch basic sizes and preferred pitches (continued)

1	2	3	4	5	6	7	8	9	10	11	12	13	14	15	16	17	18
Nominal size and threads per inch	Series designation	External threads									Internal threads						
		Class	Allowance in	Major diameter		Effective diameter			Minor diameter		Class	Minor diameter		Effective diameter			Major diameter
				Max.	Min.	Max.	Min.	Tol.	Max.	Min.		Min.	Max.	Min.	Max.	Tol.	Min.
				in	in	in	in	in	in	in		in	in	in	in	in	in
1.9 — 12	UNS	2A	0.001 8	1.898 2	1.886 8	1.844 1	1.838 0	0.006 1	1.796 0	1.783 9	2B	1.809 8	1.827 9	1.845 9	1.853 8	0.007 9	1.900 0
		3A	0.000 0	1.900 0	1.888 6	1.845 9	1.841 4	0.004 5	1.797 8	1.787 3	3B	1.809 8	1.819 8	1.845 9	1.851 8	0.005 9	1.900 0
1.9 — 16	UNS	2A	0.001 6	1.898 4	1.889 0	1.857 8	1.852 4	0.005 4	1.821 7	1.811 8	2B	1.832 3	1.846 4	1.859 4	1.866 4	0.007 0	1.900 0
		3A	0.000 0	1.900 0	1.890 6	1.859 4	1.855 4	0.004 0	1.823 3	1.814 8	3B	1.832 3	1.840 8	1.859 4	1.864 6	0.005 2	1.900 0
1.9 — 20	UNS	2A	0.001 5	1.898 5	1.890 4	1.866 0	1.861 1	0.004 9	1.837 2	1.828 7	2B	1.845 9	1.857 4	1.867 5	1.873 9	0.006 4	1.900 0
		3A	0.000 0	1.900 0	1.891 9	1.867 5	1.863 8	0.003 7	1.838 7	1.831 4	3B	1.845 9	1.853 7	1.867 5	1.872 3	0.004 8	1.900 0
2.1 — 6	UNS	2A	0.002 5	2.097 5	2.079 3	1.989 2	1.980 9	0.008 3	1.893 0	1.872 7	2B	1.919 6	1.950 2	1.991 7	2.002 5	0.010 8	2.100 0
		3A	0.000 0	2.100 0	2.081 8	1.991 7	1.985 5	0.006 2	1.895 5	1.877 3	3B	1.919 6	1.939 6	1.991 7	1.999 8	0.008 1	2.100 0
2.1 — 8	UNS	2A	0.002 2	2.097 8	2.082 8	2.016 6	2.009 4	0.007 2	1.944 4	1.928 2	2B	1.964 7	1.989 7	2.018 8	2.028 2	0.009 4	2.100 0
		3A	0.000 0	2.100 0	2.085 0	2.018 8	2.013 4	0.005 4	1.946 6	1.932 2	3B	1.964 7	1.979 7	2.018 8	2.025 9	0.007 1	2.100 0
2.1 — 12	UNS	2A	0.001 8	2.098 2	2.086 8	2.044 1	2.038 0	0.006 1	1.996 0	1.983 9	2B	2.009 8	2.027 9	2.045 9	2.053 8	0.007 9	2.100 0
		3A	0.000 0	2.100 0	2.088 6	2.045 9	2.041 4	0.004 5	1.997 8	1.987 3	3B	2.009 8	2.019 8	2.045 9	2.051 8	0.005 9	2.100 0
2.1 — 16	UNS	2A	0.001 6	2.098 4	2.089 0	2.057 8	2.052 4	0.005 4	2.021 7	2.011 8	2B	2.032 3	2.046 4	2.059 4	2.066 4	0.007 0	2.100 0
		3A	0.000 0	2.100 0	2.090 6	2.059 4	2.055 4	0.004 0	2.023 3	2.014 8	3B	2.032 3	2.040 8	2.059 4	2.064 6	0.005 2	2.100 0
2.1 — 20	UNS	2A	0.001 5	2.098 5	2.090 4	2.066 0	2.061 1	0.004 9	2.037 2	2.028 7	2B	2.045 9	2.057 4	2.067 5	2.073 9	0.006 4	2.100 0
		3A	0.000 0	2.100 0	2.091 9	2.067 5	2.063 8	0.003 7	2.038 7	2.031 4	3B	2.045 9	2.053 7	2.067 5	2.072 3	0.004 8	2.100 0
2.4 — 6	UNS	2A	0.002 5	2.397 5	2.379 3	2.289 2	2.280 8	0.008 4	2.193 0	2.172 6	2B	2.219 6	2.250 2	2.291 7	2.302 6	0.010 9	2.400 0
		3A	0.000 0	2.400 0	2.381 8	2.291 7	2.285 4	0.006 3	2.195 5	2.177 2	3B	2.219 6	2.239 6	2.291 7	2.299 9	0.008 2	2.400 0
2.4 — 8	UNS	2A	0.002 2	2.397 8	2.382 8	2.316 6	2.309 2	0.007 4	2.244 4	2.228 0	2B	2.264 7	2.289 7	2.318 8	2.328 4	0.009 6	2.400 0
		3A	0.000 0	2.400 0	2.385 0	2.318 8	2.313 3	0.005 5	2.246 6	2.232 1	3B	2.264 7	2.279 7	2.318 8	2.326 0	0.007 2	2.400 0
2.4 — 12	UNS	2A	0.001 9	2.398 1	2.386 7	2.344 0	2.337 8	0.006 2	2.295 9	2.283 7	2B	2.309 8	2.327 9	2.345 9	2.354 0	0.008 1	2.400 0
		3A	0.000 0	2.400 0	2.388 6	2.345 9	2.341 3	0.004 6	2.297 8	2.287 2	3B	2.309 8	2.319 8	2.345 9	2.351 9	0.006 0	2.400 0
2.4 — 16	UNS	2A	0.001 7	2.398 3	2.388 9	2.357 7	2.352 2	0.005 5	2.321 6	2.311 6	2B	2.332 3	2.346 4	2.359 4	2.366 6	0.007 2	2.400 0
		3A	0.000 0	2.400 0	2.390 6	2.359 4	2.355 3	0.004 1	2.323 3	2.314 7	3B	2.332 3	2.340 8	2.359 4	2.364 8	0.005 4	2.400 0
2.4 — 20	UNS	2A	0.001 5	2.398 5	2.390 4	2.366 0	2.360 9	0.005 1	2.337 2	2.328 5	2B	2.345 9	2.357 4	2.367 5	2.374 1	0.006 6	2.400 0
		3A	0.000 0	2.400 0	2.391 9	2.367 5	2.363 7	0.003 8	2.338 7	2.331 3	3B	2.345 9	2.353 7	2.367 5	2.372 5	0.005 0	2.400 0

Table 38 Limits of size for UNS threads having decimal inch basic sizes and preferred pitches (continued)

1	2	3	4	5	6	7	8	9	10	11	12	13	14	15	16	17	18
Nominal size and threads per inch	Series designation	External threads									Internal threads						
		Class	Allowance	Major diameter		Effective diameter			Minor diameter		Class	Minor diameter		Effective diameter			Major diameter
				Max.	Min.	Max.	Min.	Tol.	Max.	Min.		Min.	Max.	Min.	Tol.		
				in	in	in	in	in	in	in		in	in	in	in	in	
2.6 — 6	UNS	2A	0.002 5	2.597 5	2.579 3	2.489 2	2.480 8	0.008 4	2.393 0	2.372 6	2B	2.419 6	2.450 2	2.491 7	2.502 6	0.010 9	2.600 0
		3A	0.000 0	2.600 0	2.581 8	2.491 7	2.485 4	0.006 3	2.395 5	2.377 2	3B	2.419 6	2.439 6	2.491 7	2.499 9	0.008 2	2.600 0
2.6 — 8	UNS	2A	0.002 2	2.597 8	2.582 8	2.516 6	2.509 2	0.007 4	2.444 4	2.428 0	2B	2.464 7	2.489 7	2.518 8	2.528 4	0.009 6	2.600 0
		3A	0.000 0	2.600 0	2.585 0	2.518 8	2.513 3	0.005 5	2.446 6	2.432 1	3B	2.464 7	2.479 7	2.518 8	2.526 0	0.007 2	2.600 0
2.6 — 12	UNS	2A	0.001 9	2.598 1	2.586 7	2.544 0	2.537 8	0.006 2	2.495 9	2.483 7	2B	2.509 8	2.527 9	2.545 9	2.554 0	0.008 1	2.600 0
		3A	0.000 0	2.600 0	2.588 6	2.545 9	2.541 3	0.004 6	2.497 8	2.487 2	3B	2.509 8	2.519 8	2.545 9	2.551 9	0.006 0	2.600 0
2.6 — 16	UNS	2A	0.001 7	2.598 3	2.588 9	2.557 7	2.552 2	0.005 5	2.521 6	2.511 6	2B	2.532 3	2.546 4	2.559 4	2.566 6	0.007 2	2.600 0
		3A	0.000 0	2.600 0	2.590 6	2.559 4	2.555 3	0.004 1	2.523 3	2.514 7	3B	2.532 3	2.540 8	2.559 4	2.564 8	0.005 4	2.600 0
2.6 — 20	UNS	2A	0.001 5	2.598 5	2.590 4	2.566 0	2.560 9	0.005 1	2.537 2	2.528 5	2B	2.545 9	2.557 4	2.567 5	2.574 1	0.006 6	2.600 0
		3A	0.000 0	2.600 0	2.591 9	2.567 5	2.563 7	0.003 8	2.538 7	2.531 3	3B	2.545 9	2.553 7	2.567 5	2.572 5	0.005 0	2.600 0
2.9 — 6	UNS	2A	0.002 6	2.897 4	2.879 2	2.789 1	2.780 6	0.008 5	2.692 9	2.672 4	2B	2.719 6	2.750 2	2.791 7	2.802 8	0.011 1	2.900 0
		3A	0.000 0	2.900 0	2.881 8	2.791 7	2.785 3	0.006 4	2.695 5	2.677 1	3B	2.719 6	2.739 6	2.791 7	2.800 0	0.008 3	2.900 0
2.9 — 8	UNS	2A	0.002 3	2.897 7	2.882 7	2.816 5	2.809 0	0.007 5	2.744 3	2.727 8	2B	2.764 7	2.789 7	2.818 8	2.828 6	0.009 8	2.900 0
		3A	0.000 0	2.900 0	2.885 0	2.818 8	2.813 2	0.005 6	2.746 6	2.732 0	3B	2.764 7	2.779 7	2.818 8	2.826 1	0.007 3	2.900 0
2.9 — 12	UNS	2A	0.001 9	2.898 1	2.886 7	2.844 0	2.837 7	0.006 3	2.795 9	2.783 6	2B	2.809 8	2.827 9	2.845 9	2.854 1	0.008 2	2.900 0
		3A	0.000 0	2.900 0	2.888 6	2.845 9	2.841 2	0.004 7	2.797 8	2.787 1	3B	2.809 8	2.819 8	2.845 9	2.852 1	0.006 2	2.900 0
2.9 — 16	UNS	2A	0.001 7	2.898 3	2.888 9	2.857 7	2.852 0	0.005 7	2.821 6	2.811 4	2B	2.832 3	2.846 4	2.859 4	2.866 7	0.007 3	2.900 0
		3A	0.000 0	2.900 0	2.890 6	2.859 4	2.855 2	0.004 2	2.823 3	2.814 6	3B	2.832 3	2.840 8	2.859 4	2.864 9	0.005 5	2.900 0
2.9 — 20	UNS	2A	0.001 6	2.898 4	2.890 3	2.865 9	2.860 7	0.005 2	2.837 1	2.828 3	2B	2.845 9	2.857 4	2.867 5	2.874 3	0.006 8	2.900 0
		3A	0.000 0	2.900 0	2.891 9	2.867 5	2.863 6	0.003 9	2.838 7	2.831 2	3B	2.845 9	2.853 7	2.867 5	2.872 6	0.005 1	2.900 0
3.1 — 6	UNS	2A	0.002 6	3.097 4	3.079 2	2.989 1	2.980 6	0.008 5	2.892 9	2.872 4	2B	2.919 6	2.950 2	2.991 7	3.002 8	0.011 1	3.100 0
		3A	0.000 0	3.100 0	3.081 8	2.991 7	2.985 3	0.006 4	2.895 5	2.877 1	3B	2.919 6	2.939 6	2.991 7	3.000 0	0.008 3	3.100 0
3.1 — 8	UNS	2A	0.002 3	3.097 7	3.082 7	3.016 5	3.009 0	0.007 5	2.944 3	2.927 8	2B	2.964 7	2.989 7	3.018 8	3.028 6	0.009 8	3.100 0
		3A	0.000 0	3.100 0	3.085 0	3.018 8	3.013 2	0.005 6	2.946 6	2.932 0	3B	2.964 7	2.979 7	3.018 8	3.026 1	0.007 3	3.100 0
3.1 — 12	UNS	2A	0.001 9	3.098 1	3.086 7	3.044 0	3.037 7	0.006 3	2.995 9	2.983 6	2B	3.009 8	3.027 9	3.045 9	3.054 1	0.008 2	3.100 0
		3A	0.000 0	3.100 0	3.088 6	3.045 9	3.041 2	0.004 7	2.997 8	2.987 1	3B	3.009 8	3.019 8	3.045 9	3.052 1	0.006 2	3.100 0

Table 38 Limits of size for UNS threads having decimal inch basic sizes and preferred pitches (continued)

1	2	3	4	5	6	7	8	9	10	11	12	13	14	15	16	17	18
Nominal size and threads per inch	Series designation	External threads									Internal threads						
		Class	Allowance	Major diameter		Effective diameter			Minor diameter		Class	Minor diameter		Effective diameter			Major diameter
				Max.	Min.	Max.	Min.	Tol.	Max.	Min.		Min.	Max.	Min.	Tol.		
				in	in	in	in	in	in	in		in	in	in	in	in	
3.1 — 16	UNS	2A	0.001 7	3.098 3	3.088 9	3.057 7	3.052 0	0.005 7	3.021 6	3.011 4	2B	3.032 3	3.046 4	3.059 4	3.066 7	0.007 3	3.100 0
		3A	0.000 0	3.100 0	3.090 6	3.059 4	3.055 2	0.004 2	3.023 3	3.014 6	3B	3.032 3	3.040 8	3.059 4	3.064 9	0.005 5	3.100 0
3.4 — 6	UNS	2A	0.002 6	3.397 4	3.379 2	3.289 1	3.280 4	0.008 7	3.192 9	3.172 2	2B	3.219 6	3.250 2	3.291 7	3.303 0	0.011 3	3.400 0
		3A	0.000 0	3.400 0	3.381 8	3.291 7	3.285 2	0.006 5	3.195 5	3.177 0	3B	3.219 6	3.239 6	3.291 7	3.300 1	0.008 4	3.400 0
3.4 — 8	UNS	2A	0.002 3	3.397 7	3.382 7	3.316 5	3.308 9	0.007 6	3.244 3	3.227 7	2B	3.264 7	3.289 7	3.318 8	3.328 7	0.009 9	3.400 0
		3A	0.000 0	3.400 0	3.385 0	3.318 8	3.313 1	0.005 7	3.246 6	3.231 9	3B	3.264 7	3.279 7	3.318 8	3.326 2	0.007 4	3.400 0
3.4 — 12	UNS	2A	0.001 9	3.398 1	3.386 7	3.344 0	3.337 6	0.006 4	3.295 9	3.283 5	2B	3.309 8	3.327 9	3.345 9	3.354 3	0.008 4	3.400 0
		3A	0.000 0	3.400 0	3.388 6	3.345 9	3.341 1	0.004 8	3.297 8	3.287 0	3B	3.309 8	3.319 8	3.345 9	3.352 2	0.006 3	3.400 0
3.4 — 16	UNS	2A	0.001 7	3.398 3	3.388 9	3.357 7	3.351 9	0.005 8	3.321 6	3.311 3	2B	3.332 3	3.346 4	3.359 4	3.366 9	0.007 5	3.400 0
		3A	0.000 0	3.400 0	3.390 6	3.359 4	3.355 1	0.004 3	3.323 3	3.314 5	3B	3.332 3	3.340 8	3.359 4	3.365 0	0.005 6	3.400 0
3.6 — 6	UNS	2A	0.002 6	3.597 4	3.579 2	3.489 1	3.480 4	0.008 7	3.392 9	3.372 2	2B	3.419 6	3.450 2	3.491 7	3.503 0	0.011 3	3.600 0
		3A	0.000 0	3.600 0	3.581 8	3.491 7	3.485 2	0.006 5	3.395 5	3.377 0	3B	3.419 6	3.439 6	3.491 7	3.500 1	0.008 4	3.600 0
3.6 — 8	UNS	2A	0.002 3	3.597 7	3.582 7	3.516 5	3.508 9	0.007 6	3.444 3	3.427 7	2B	3.464 7	3.489 7	3.518 8	3.528 7	0.009 9	3.600 0
		3A	0.000 0	3.600 0	3.585 0	3.518 8	3.513 1	0.005 7	3.446 6	3.431 9	3B	3.464 7	3.479 7	3.518 8	3.526 2	0.007 4	3.600 0
3.6 — 12	UNS	2A	0.001 9	3.598 1	3.586 7	3.544 0	3.537 6	0.006 4	3.495 9	3.483 5	2B	3.509 8	3.527 9	3.545 9	3.554 3	0.008 4	3.600 0
		3A	0.000 0	3.600 0	3.588 6	3.545 9	3.541 1	0.004 8	3.497 8	3.487 0	3B	3.509 8	3.519 8	3.545 9	3.552 2	0.006 3	3.600 0
3.6 — 16	UNS	2A	0.001 7	3.598 3	3.588 9	3.557 7	3.551 9	0.005 8	3.521 6	3.511 3	2B	3.532 3	3.546 4	3.559 4	3.566 9	0.007 5	3.600 0
		3A	0.000 0	3.600 0	3.590 6	3.559 4	3.555 1	0.004 3	3.523 3	3.514 5	3B	3.532 3	3.540 8	3.559 4	3.565 0	0.005 6	3.600 0
3.9 — 6	UNS	2A	0.002 6	3.897 4	3.879 2	3.789 1	3.780 3	0.008 8	3.692 9	3.672 1	2B	3.719 6	3.750 2	3.791 7	3.803 1	0.011 4	3.900 0
		3A	0.000 0	3.900 0	3.881 8	3.791 7	3.785 1	0.006 6	3.695 5	3.676 9	3B	3.719 6	3.739 6	3.791 7	3.800 2	0.008 5	3.900 0
3.9 — 8	UNS	2A	0.002 3	3.897 7	3.882 7	3.816 5	3.808 8	0.007 7	3.744 3	3.727 6	2B	3.764 7	3.789 7	3.818 8	3.828 8	0.010 0	3.900 0
		3A	0.000 0	3.900 0	3.885 0	3.818 8	3.813 0	0.005 8	3.746 6	3.731 8	3B	3.764 7	3.779 7	3.818 8	3.826 3	0.007 5	3.900 0
3.9 — 12	UNS	2A	0.002 0	3.898 0	3.886 6	3.843 9	3.837 4	0.006 5	3.795 8	3.783 3	2B	3.809 8	3.827 9	3.845 9	3.854 4	0.008 5	3.900 0
		3A	0.000 0	3.900 0	3.888 6	3.845 9	3.841 0	0.004 9	3.797 8	3.786 9	3B	3.809 8	3.819 8	3.845 9	3.852 3	0.006 4	3.900 0
3.9 — 16	UNS	2A	0.001 8	3.898 2	3.888 8	3.857 6	3.851 7	0.005 9	3.821 5	3.811 1	2B	3.832 3	3.846 4	3.859 4	3.867 0	0.007 6	3.900 0
		3A	0.000 0	3.900 0	3.890 6	3.859 4	3.855 0	0.004 4	3.823 3	3.814 4	3B	3.832 3	3.840 8	3.859 4	3.865 1	0.005 7	3.900 0

Table 38 Limits of size for UNS threads having decimal inch basic sizes and preferred pitches (continued)

1	2	3	4	5	6	7	8	9	10	11	12	13	14	15	16	17	18
Nominal size and threads per inch	Series designation	External threads									Internal threads						
		Class	Allowance	Major diameter		Effective diameter			Minor diameter		Class	Minor diameter		Effective diameter			Major diameter
				Max.	Min.	Max.	Min.	Tol.	Max.	Min.		Min.	Max.	Min.	Tol.		
				in	in	in	in	in	in	in		in	in	in	in	in	
4.1 — 6	UNS	2A	0.002 6	4.097 4	4.079 2	3.989 1	3.980 3	0.008 8	3.892 9	3.872 1	2B	3.919 6	3.950 2	3.991 7	4.003 1	0.011 4	4.100 0
		3A	0.000 0	4.100 0	4.081 8	3.991 7	3.985 1	0.006 6	3.895 5	3.876 9	3B	3.919 6	3.939 6	3.991 7	4.000 2	0.008 5	4.100 0
4.1 — 8	UNS	2A	0.002 3	4.097 7	4.082 7	4.016 5	4.008 8	0.007 7	3.944 3	3.927 6	2B	3.964 7	3.989 7	4.018 8	4.028 8	0.010 0	4.100 0
		3A	0.000 0	4.100 0	4.085 0	4.018 8	4.013 0	0.005 8	3.946 6	3.931 8	3B	3.964 7	3.979 7	4.018 8	4.026 3	0.007 5	4.100 0
4.1 — 12	UNS	2A	0.002 0	4.098 0	4.086 6	4.043 9	4.037 4	0.006 5	3.995 8	3.983 3	2B	4.009 8	4.027 9	4.045 9	4.054 4	0.008 5	4.100 0
		3A	0.000 0	4.100 0	4.088 6	4.045 9	4.041 0	0.004 9	3.997 8	3.986 9	3B	4.009 8	4.019 8	4.045 9	4.052 3	0.006 4	4.100 0
4.1 — 16	UNS	2A	0.001 8	4.098 2	4.088 8	4.057 6	4.051 7	0.005 9	4.021 5	4.011 1	2B	4.032 3	4.046 4	4.059 4	4.067 0	0.007 6	4.100 0
		3A	0.000 0	4.100 0	4.090 6	4.059 4	4.055 0	0.004 4	4.023 3	4.014 4	3B	4.032 3	4.040 8	4.059 4	4.065 1	0.005 7	4.100 0
4.4 — 4	UNS	2A	0.003 2	4.396 8	4.373 0	4.234 4	4.223 8	0.010 6	4.090 1	4.061 5	2B	4.129 4	4.166 9	4.237 6	4.251 4	0.013 8	4.400 0
		3A	0.000 0	4.400 0	4.376 2	4.237 6	4.229 7	0.007 9	4.093 3	4.067 4	3B	4.129 4	4.159 4	4.237 6	4.247 9	0.010 3	4.400 0
4.4 — 6	UNS	2A	0.002 6	4.397 4	4.379 2	4.289 1	4.280 3	0.008 8	4.192 9	4.172 1	2B	4.219 6	4.250 2	4.291 7	4.303 1	0.011 4	4.400 0
		3A	0.000 0	4.400 0	4.381 8	4.291 7	4.285 1	0.006 6	4.195 5	4.176 9	3B	4.219 6	4.239 6	4.291 7	4.300 2	0.008 5	4.400 0
4.4 — 8	UNS	2A	0.002 3	4.397 7	4.382 7	4.316 5	4.308 8	0.007 7	4.244 3	4.227 6	2B	4.264 7	4.289 7	4.318 8	4.328 8	0.010 0	4.400 0
		3A	0.000 0	4.400 0	4.385 0	4.318 8	4.313 0	0.005 8	4.246 6	4.231 8	3B	4.264 7	4.279 7	4.318 8	4.326 3	0.007 5	4.400 0
4.4 — 12	UNS	2A	0.002 0	4.398 0	4.386 6	4.343 9	4.337 4	0.006 5	4.295 8	4.283 3	2B	4.309 8	4.327 9	4.345 9	4.354 4	0.008 5	4.400 0
		3A	0.000 0	4.400 0	4.388 6	4.345 9	4.341 0	0.004 9	4.297 8	4.286 9	3B	4.309 8	4.319 8	4.345 9	4.352 3	0.006 4	4.400 0
4.4 — 16	UNS	2A	0.001 8	4.398 2	4.388 8	4.357 6	4.351 7	0.005 9	4.321 5	4.311 1	2B	4.332 3	4.346 4	4.359 4	4.367 0	0.007 6	4.400 0
		3A	0.000 0	4.400 0	4.390 6	4.359 4	4.355 0	0.004 4	4.323 3	4.314 4	3B	4.332 3	4.340 8	4.359 4	4.365 1	0.005 7	4.400 0
4.6 — 4	UNS	2A	0.003 2	4.596 8	4.573 0	4.434 4	4.423 6	0.010 8	4.290 1	4.261 3	2B	4.329 4	4.366 9	4.437 6	4.451 6	0.014 0	4.600 0
		3A	0.000 0	4.600 0	4.576 2	4.437 6	4.429 5	0.008 1	4.293 3	4.267 2	3B	4.329 4	4.359 4	4.437 6	4.448 1	0.010 5	4.600 0
4.6 — 6	UNS	2A	0.002 7	4.597 3	4.579 1	4.489 0	4.480 1	0.008 9	4.392 8	4.371 9	2B	4.419 6	4.450 2	4.491 7	4.503 3	0.011 6	4.600 0
		3A	0.000 0	4.600 0	4.581 8	4.491 7	4.485 0	0.006 7	4.395 5	4.376 8	3B	4.419 6	4.439 6	4.491 7	4.500 4	0.008 7	4.600 0
4.6 — 8	UNS	2A	0.002 4	4.597 6	4.582 6	4.516 4	4.508 5	0.007 9	4.444 2	4.427 3	2B	4.464 7	4.489 7	4.518 8	4.529 1	0.010 3	4.600 0
		3A	0.000 0	4.600 0	4.585 0	4.518 8	4.512 9	0.005 9	4.446 6	4.431 7	3B	4.464 7	4.479 7	4.518 8	4.526 5	0.007 7	4.600 0
4.6 — 12	UNS	2A	0.002 0	4.598 0	4.586 6	4.543 9	4.537 2	0.006 7	4.495 8	4.483 1	2B	4.509 8	4.527 9	4.545 9	4.554 6	0.008 7	4.600 0
		3A	0.000 0	4.600 0	4.588 6	4.545 9	4.540 9	0.005 0	4.497 8	4.486 8	3B	4.509 8	4.519 8	4.545 9	4.552 5	0.006 6	4.600 0
4.6 — 16	UNS	2A	0.001 8	4.598 2	4.588 8	4.557 6	4.551 5	0.006 1	4.521 5	4.510 9	2B	4.532 3	4.546 4	4.559 4	4.567 3	0.007 9	4.600 0
		3A	0.000 0	4.600 0	4.590 6	4.559 4	4.554 9	0.004 5	4.523 3	4.514 3	3B	4.532 3	4.540 8	4.559 4	4.565 3	0.005 9	4.600 0

Table 38 Limits of size for UNS threads having decimal inch basic sizes and preferred pitches (continued)

1	2	3	4	5	6	7	8	9	10	11	12	13	14	15	16	17	18
Nominal size and threads per inch	Series designation	External threads									Internal threads						
		Class	Allowance in	Major diameter		Effective diameter			Minor diameter		Class	Minor diameter		Effective diameter			Major diameter
				Max.	Min.	Max.	Min.	Tol.	Max.	Min.		Min.	Max.	Min.	Max.	Tol.	Min.
				in	in	in	in	in	in	in		in	in	in	in	in	in
4.9 — 4	UNS	2A	0.003 2	4.896 8	4.873 0	4.734 4	4.723 6	0.010 8	4.590 1	4.561 3	2B	4.629 4	4.666 9	4.737 6	4.751 6	0.014 0	4.900 0
		3A	0.000 0	4.900 0	4.876 2	4.737 6	4.729 5	0.008 1	4.593 3	4.567 2	3B	4.629 4	4.659 4	4.737 6	4.748 1	0.010 5	4.900 0
4.9 — 6	UNS	2A	0.002 7	4.897 3	4.879 1	4.789 0	4.780 1	0.008 9	4.692 8	4.671 9	2B	4.719 6	4.750 2	4.791 7	4.803 3	0.011 6	4.900 0
		3A	0.000 0	4.900 0	4.881 8	4.791 7	4.785 0	0.006 7	4.695 5	4.676 8	3B	4.719 6	4.739 6	4.791 7	4.800 4	0.008 7	4.900 0
4.9 — 8	UNS	2A	0.002 4	4.897 6	4.882 6	4.816 4	4.808 5	0.007 9	4.744 2	4.727 3	2B	4.764 7	4.789 7	4.818 8	4.829 1	0.010 3	4.900 0
		3A	0.000 0	4.900 0	4.885 0	4.818 8	4.812 9	0.005 9	4.746 6	4.731 7	3B	4.764 7	4.779 7	4.818 8	4.826 5	0.007 7	4.900 0
4.9 — 12	UNS	2A	0.002 0	4.898 0	4.886 6	4.843 9	4.837 2	0.006 7	4.795 8	4.783 1	2B	4.809 8	4.827 9	4.845 9	4.854 6	0.008 7	4.900 0
		3A	0.000 0	4.900 0	4.888 6	4.845 9	4.840 9	0.005 0	4.797 8	4.786 8	3B	4.809 8	4.819 8	4.845 9	4.852 5	0.006 6	4.900 0
4.9 — 16	UNS	2A	0.001 8	4.898 2	4.888 8	4.857 6	4.851 5	0.006 1	4.821 5	4.810 9	2B	4.832 3	4.846 4	4.859 4	4.867 3	0.007 9	4.900 0
		3A	0.000 0	4.900 0	4.890 6	4.859 4	4.854 9	0.004 5	4.823 3	4.814 3	3B	4.832 3	4.840 8	4.859 4	4.865 3	0.005 9	4.900 0
5.1 — 4	UNS	2A	0.003 2	5.096 8	5.073 0	4.934 4	4.923 6	0.010 8	4.790 1	4.761 3	2B	4.829 4	4.866 9	4.937 6	4.951 6	0.014 0	5.100 0
		3A	0.000 0	5.100 0	5.076 2	4.937 6	4.929 5	0.008 1	4.793 3	4.767 2	3B	4.829 4	4.859 4	4.937 6	4.948 1	0.010 5	5.100 0
5.1 — 6	UNS	2A	0.002 7	5.097 3	5.079 1	4.989 0	4.980 1	0.008 9	4.892 8	4.871 9	2B	4.919 6	4.950 2	4.991 7	5.003 3	0.011 6	5.100 0
		3A	0.000 0	5.100 0	5.081 8	4.991 7	4.985 0	0.006 7	4.895 5	4.876 8	3B	4.919 6	4.939 6	4.991 7	5.000 4	0.008 7	5.100 0
5.1 — 8	UNS	2A	0.002 4	5.097 6	5.082 6	5.016 4	5.008 5	0.007 9	4.944 2	4.927 3	2B	4.964 7	4.989 7	5.018 8	5.029 1	0.010 3	5.100 0
		3A	0.000 0	5.100 0	5.085 0	5.018 8	5.012 9	0.005 9	4.946 6	4.931 7	3B	4.964 7	4.979 7	5.018 8	5.026 5	0.007 7	5.100 0
5.1 — 12	UNS	2A	0.002 0	5.098 0	5.086 6	5.043 9	5.037 2	0.006 7	4.995 8	4.983 1	2B	5.009 8	5.027 9	5.045 9	5.054 6	0.008 7	5.100 0
		3A	0.000 0	5.100 0	5.088 6	5.045 9	5.040 9	0.005 0	4.997 8	4.986 8	3B	5.009 8	5.019 8	5.045 9	5.052 5	0.006 6	5.100 0
5.1 — 16	UNS	2A	0.001 8	5.098 2	5.088 8	5.057 6	5.051 5	0.006 1	5.021 5	5.010 9	2B	5.032 3	5.046 4	5.059 4	5.067 3	0.007 9	5.100 0
		3A	0.000 0	5.100 0	5.090 6	5.059 4	5.054 9	0.004 5	5.023 3	5.014 3	3B	5.032 3	5.040 8	5.059 4	5.065 3	0.005 9	5.100 0
5.4 — 4	UNS	2A	0.003 2	5.396 8	5.373 0	5.234 4	5.223 6	0.010 8	5.090 1	5.061 3	2B	5.129 4	5.166 9	5.237 6	5.251 6	0.014 0	5.400 0
		3A	0.000 0	5.400 0	5.376 2	5.237 6	5.229 5	0.008 1	5.093 3	5.067 2	3B	5.129 4	5.159 4	5.237 6	5.248 1	0.010 5	5.400 0
5.4 — 6	UNS	2A	0.002 7	5.397 3	5.379 1	5.289 0	5.280 1	0.008 9	5.192 8	5.171 9	2B	5.219 6	5.250 2	5.291 7	5.303 3	0.011 6	5.400 0
		3A	0.000 0	5.400 0	5.381 8	5.291 7	5.285 0	0.006 7	5.195 5	5.176 8	3B	5.219 6	5.239 6	5.291 7	5.300 4	0.008 7	5.400 0
5.4 — 8	UNS	2A	0.002 4	5.397 6	5.382 6	5.316 4	5.308 5	0.007 9	5.244 2	5.227 3	2B	5.264 7	5.289 7	5.318 8	5.329 1	0.010 3	5.400 0
		3A	0.000 0	5.400 0	5.385 0	5.318 8	5.312 9	0.005 9	5.246 6	5.231 7	3B	5.264 7	5.279 7	5.318 8	5.326 5	0.007 7	5.400 0
5.4 — 12	UNS	2A	0.002 0	5.398 0	5.386 6	5.343 9	5.337 2	0.006 7	5.295 8	5.283 1	2B	5.309 8	5.327 9	5.345 9	5.354 6	0.008 7	5.400 0
		3A	0.000 0	5.400 0	5.388 6	5.345 9	5.340 9	0.005 0	5.297 8	5.286 8	3B	5.309 8	5.319 8	5.345 9	5.352 5	0.006 6	5.400 0

Table 38 Limits of size for UNS threads having decimal inch basic sizes and preferred pitches (concluded)

1	2	3	4	5	6	7	8	9	10	11	12	13	14	15	16	17	18
Nominal size and threads per inch	Series designation	External threads									Internal threads						
		Class	Allowance	Major diameter		Effective diameter			Minor diameter		Class	Minor diameter		Effective diameter			Major diameter
				Max.	Min.	Max.	Min.	Tol.	Max.	Min.		Min.	Max.	Min.	Max.	Tol.	
				in	in	in	in	in	in	in		in	in	in	in	in	
5.4 — 16	UNS	2A	0.001 8	5.398 2	5.388 8	5.357 6	5.351 5	0.006 1	5.321 5	5.310 9	2B	5.332 3	5.346 4	5.359 4	5.367 3	0.007 9	5.400 0
		3A	0.000 0	5.400 0	5.390 6	5.359 4	5.354 9	0.004 5	5.323 3	5.314 3	3B	5.332 3	5.340 8	5.359 4	5.365 3	0.005 9	5.400 0
5.6 — 4	UNS	2A	0.003 3	5.596 7	5.572 9	5.434 3	5.423 4	0.010 9	5.290 0	5.261 1	2B	5.329 4	5.366 9	5.437 6	5.451 8	0.014 2	5.600 0
		3A	0.000 0	5.600 0	5.576 2	5.437 6	5.429 4	0.008 2	5.293 3	5.267 1	3B	5.329 4	5.359 4	5.437 6	5.448 3	0.010 7	5.600 0
5.6 — 6	UNS	2A	0.002 7	5.597 3	5.579 1	5.489 0	5.479 9	0.009 1	5.392 8	5.371 7	2B	5.419 6	5.450 2	5.491 7	5.503 5	0.011 8	5.600 0
		3A	0.000 0	5.600 0	5.581 8	5.491 7	5.484 9	0.006 8	5.395 5	5.376 7	3B	5.419 6	5.439 6	5.491 7	5.500 6	0.008 9	5.600 0
5.6 — 8	UNS	2A	0.002 4	5.597 6	5.582 6	5.516 4	5.508 3	0.008 1	5.444 2	5.427 1	2B	5.464 7	5.489 7	5.518 8	5.529 3	0.010 5	5.600 0
		3A	0.000 0	5.600 0	5.585 0	5.518 8	5.512 7	0.006 1	5.446 6	5.431 5	3B	5.464 7	5.479 7	5.518 8	5.526 7	0.007 9	5.600 0
5.6 — 12	UNS	2A	0.002 1	5.597 9	5.586 5	5.543 8	5.536 9	0.006 9	5.495 7	5.482 8	2B	5.509 8	5.527 9	5.545 9	5.554 9	0.009 0	5.600 0
		3A	0.000 0	5.600 0	5.588 6	5.545 9	5.540 7	0.005 2	5.497 8	5.486 6	3B	5.509 8	5.519 8	5.545 9	5.552 6	0.006 7	5.600 0
5.6 — 16	UNS	2A	0.001 9	5.598 1	5.588 7	5.557 5	5.551 3	0.006 2	5.521 4	5.510 7	2B	5.532 3	5.546 4	5.559 4	5.567 5	0.008 1	5.600 0
		3A	0.000 0	5.600 0	5.590 6	5.559 4	5.554 7	0.004 7	5.523 3	5.514 1	3B	5.532 3	5.540 8	5.559 4	5.565 5	0.006 1	5.600 0
5.9 — 4	UNS	2A	0.003 3	5.896 7	5.872 9	5.734 3	5.723 4	0.010 9	5.590 0	5.561 1	2B	5.629 4	5.666 9	5.737 6	5.751 8	0.014 2	5.900 0
		3A	0.000 0	5.900 0	5.876 2	5.737 6	5.729 4	0.008 2	5.593 3	5.567 1	3B	5.629 4	5.659 4	5.737 6	5.748 3	0.010 7	5.900 0
5.9 — 6	UNS	2A	0.002 7	5.897 3	5.879 1	5.789 0	5.779 9	0.009 1	5.692 8	5.671 7	2B	5.719 6	5.750 2	5.791 7	5.803 5	0.011 8	5.900 0
		3A	0.000 0	5.900 0	5.881 8	5.791 7	5.784 9	0.006 8	5.695 5	5.676 7	3B	5.719 6	5.739 6	5.791 7	5.800 6	0.008 9	5.900 0
5.9 — 8	UNS	2A	0.002 4	5.897 6	5.882 6	5.816 4	5.808 3	0.008 1	5.744 2	5.727 1	2B	5.764 7	5.789 7	5.818 8	5.829 3	0.010 5	5.900 0
		3A	0.000 0	5.900 0	5.885 0	5.818 8	5.812 7	0.006 1	5.746 6	5.731 5	3B	5.764 7	5.779 7	5.818 8	5.826 7	0.007 9	5.900 0
5.9 — 12	UNS	2A	0.002 1	5.897 9	5.886 5	5.843 8	5.836 9	0.006 9	5.795 7	5.782 8	2B	5.809 8	5.827 9	5.845 9	5.854 9	0.009 0	5.900 0
		3A	0.000 0	5.900 0	5.888 6	5.845 9	5.840 7	0.005 2	5.797 8	5.786 6	3B	5.809 8	5.819 8	5.845 9	5.852 6	0.006 7	5.900 0
5.9 — 16	UNS	2A	0.001 9	5.898 1	5.888 7	5.857 5	5.851 3	0.006 2	5.821 4	5.810 7	2B	5.832 3	5.846 4	5.859 4	5.867 5	0.008 1	5.900 0
		3A	0.000 0	5.900 0	5.890 6	5.859 4	5.854 7	0.004 7	5.823 3	5.814 1	3B	5.832 3	5.840 8	5.859 4	5.865 5	0.006 1	5.900 0

Annex A (informative) **Bases of tolerances and allowances for unified screw threads $\frac{1}{4}$ in and larger**

A.1 **General**

In deciding upon suitable bases for calculating tolerances and allowances for unified screw threads $\frac{1}{4}$ in diameter and larger, the aim has been to provide a minimum number of simple formulae which would be applicable to the several classes and to all reasonable combinations of diameter and pitch. The formulae adopted give tolerances sufficiently large for the usual methods of screw thread manufacture, but not so large that the functioning of the screw threads is impaired.

The formulae are given in Table A.1 and relate to finished uncoated threads.

The tolerances on internal threads are positive and have been applied to the basic size and to sizes above the basic size. The tolerances on external threads are negative and have been applied to the basic size less the allowance, if any, and to sizes below that size.

A.2 **Tolerance classes**

The relative magnitudes and positions of the effective diameter tolerance zones for the three tolerance classes of internal and external threads are shown in Figure 4 (for finished uncoated threads).

Owing to the relative difficulties of manufacture of internal and external threads, the internal thread effective diameter tolerances have been made 30% greater than the corresponding external thread effective diameter tolerances for threads of the same class.

The effective diameter tolerances specified for Class 1A external threads and Class 1B internal threads are one-and-a-half times the corresponding tolerance values for Class 2A and Class 2B threads, respectively.

The effective diameter tolerances specified for Class 3A external threads and Class 3B internal threads are three-quarters of the corresponding tolerance values for Class 2A and Class 2B threads, respectively.

A.3 **Allowances**

Class 1A and Class 2A external threads have an allowance equal to 30% of the effective diameter tolerance for Class 2A external threads.

Class 3A external threads have no allowance.

A.4 **Effective diameter tolerances**

The basic formula that has been used for calculating the effective diameter tolerance for Class 2A external threads is:

$$0.0015\sqrt[3]{D} + 0.0015\sqrt{L_e} + 0.015\sqrt[3]{P^2}$$

where:

D is the basic major diameter;

L_e is the length of engagement;

P is the pitch of the thread.

The three components of the effective diameter tolerance are intended to accommodate respectively, deviations in the simple effective diameter, deviations in cumulative pitch over the length of engagement and deviations in the flank angles of the thread. The formula is the same as that given in ASME B1.1-2003, 5.8.1c).

This formula is based on the accuracy of present day screwing tools and methods of production, and is applicable to all practical combinations of diameter and pitch. Effective diameter tolerances for all classes of internal threads and Classes 1A and 3A external threads, have been obtained by multiplying the values obtained from this formula by the factors given in A.2, as summarized in Table A.1. The normal tolerances have been calculated for specific lengths of engagement as follows.

- a) For UNC, UNF, 4 UN, 6 UN and 8 UN threads, a length of engagement equal to one diameter has been used.
- b) For UNEF, 12 UN, 16 UN, 20 UN, 28 UN, 32 UN and all UNS threads, a length of engagement equal to $9P$ has been used.

A.5 Major diameter tolerances

A.5.1 External threads

The formulae that have been used for calculating the major diameter tolerances for external threads are as follows:

$$\text{Class 1A: } 0.09\sqrt[3]{P^2}$$

$$\text{Class 2A and Class 3A: } 0.06\sqrt[3]{P^2}$$

A.5.2 Internal threads

Following existing practice, no tolerances are specified for the major diameters of internal threads, but only a minimum size which is the same as the basic major diameter (see 4.2).

A.6 Minor diameter tolerances

A.6.1 External threads

The tolerances for the minor diameters of external threads are related to the corresponding effective diameter tolerances, since the roots of external threads are formed in the same manufacturing operation as the flanks. Account has also been taken of the fact that wear on the cutting or forming tool is greater on the crests of the tool-thread than on the flanks. This is commonly allowed for in practice by making the crests of the thread on the tool to a smaller radius than the basic root radius of the external thread.

Making the minor diameter tolerance on an external thread larger than the corresponding effective diameter tolerance by an amount equal to $0.072P$ allows new tools to have a crest radius as small as $0.108\ 3P$; tools may also safely be retained in service until the crest radius wears to the basic root radius of the external thread, i.e. $0.144\ 3P$. (See Figure 6, Figure 7 and Figure 8.)

A.6.2 Internal threads

A.6.2.1 General

The internal thread minor diameter is normally formed by an operation prior to threading. Theoretically, the tolerance could be based entirely on the diameter, but in practice such a basis might be dangerous, as fine and coarse pitches associated with large diameters would have the same tolerances. In order to ensure an adequate depth of engagement and reduce the possibility of “cross threading” of fine pitches associated with large diameters, the internal thread minor diameter tolerances have been based on the formulae given in **A.6.2.2** and **A.6.2.3**.

NOTE These formulae are applicable to threads with lengths of engagement of $\frac{2}{3}$ to $1\frac{1}{2}$ diameters.

A.6.2.2 Class 1B and Class 2B

The minor diameter tolerances have been based on the following formula:

$$0.25P - 0.4P^2$$

This formula is applicable to all threads $\frac{1}{4}$ in diameter and above and 80 t.p.i. to 4 t.p.i. [This corresponds to a minimum thread height of internal threads ranging from 65% for 80 t.p.i. to 72% for 4 t.p.i. (see Note).] For threads coarser than 4 t.p.i. the tolerance is $0.15P$.

NOTE On the basis that 100% corresponds to $(3/4)H$. On the same basis the maximum thread height of an internal thread $(5/8)H$ is $83\frac{1}{8}\%$.

A.6.2.3 Class 3B

The minor diameter tolerance has been based on the following formula:

$$0.05\sqrt[3]{P^2} + 0.03P/D - 0.002$$

with the following lower limits:

- a) minimum tolerance $0.23P - 1.5P^2$ for 80 t.p.i. to 13 t.p.i. inclusive. [This corresponds to a minimum thread height of internal threads ranging from 67% for 80 t.p.i. to 74% for 13 t.p.i.(see Note).]
- b) minimum tolerance $0.120P$ for 12 t.p.i. and coarser. [This corresponds to a minimum thread height of internal threads of 74% (see Note).]

NOTE On the basis that 100% corresponds to $(3/4)H$. On the same basis the maximum thread height of an internal thread $(5/8)H$ is $83\frac{1}{8}\%$.

A.7 Depth of thread engagement

The depth of engagement (radial amount of thread overlap) between a pair of basic size external and internal screw threads is $(5/8)H$. This is the maximum value. For two screw threads in their minimum material conditions and assembled co-axially, the depth of engagement is reduced to:

- $(5/8)H$ minus $\frac{1}{2}$ (sum of tolerances on major diameter of external thread and minor diameter of internal thread) minus $\frac{1}{2}$ allowance (if any); or
- $\frac{1}{2}$ (minimum limit of external thread major diameter minus maximum limit of internal thread minor diameter).

For the standard screw threads given in Table 1, the minimum depths of engagement calculated from their limits given in Table 2 are as follows, when expressed as percentages of $(5/8)H$:

- Classes 2A and 2B: 56% for 32 t.p.i. increasing to 76% for 4 t.p.i.;
- Classes 1A and 1B (UNC and UNF only): 49% for 28 t.p.i. increasing to 72% for 4 t.p.i.

Table A.1 Limits of size of unified threads as given by screw thread tolerance formulae

External threads						
Thread classes	Major diameter		Effective diameter		Minor diameter	
	Max.	Minus tolerance	Max.	Minus tolerance	Max.	Minus tolerance
1A	$D-G$	$0.09\sqrt[3]{P^2}$	$E-G$	$1.5\left(0.0015\sqrt[3]{D} + 0.0015\sqrt{L_e} + 0.015\sqrt[3]{P^2}\right)$	$D-G - 1\frac{5}{12}H$	$1.5\left(0.0015\sqrt[3]{D} + 0.0015\sqrt{L_e} + 0.015\sqrt[3]{P^2}\right) + H/12$
2A	$D-G$	$0.06\sqrt[3]{P^2}$	$E-G$	$\left(0.0015\sqrt[3]{D} + 0.0015\sqrt{L_e} + 0.015\sqrt[3]{P^2}\right)$	$D-G - 1\frac{5}{12}H$	$\left(0.0015\sqrt[3]{D} + 0.0015\sqrt{L_e} + 0.015\sqrt[3]{P^2}\right) + H/12$
3A	D	$0.06\sqrt[3]{P^2}$	E	$0.75\left(0.0015\sqrt[3]{D} + 0.0015\sqrt{L_e} + 0.015\sqrt[3]{P^2}\right)$	$D - 1\frac{5}{12}H$	$0.75\left(0.0015\sqrt[3]{D} + 0.0015\sqrt{L_e} + 0.015\sqrt[3]{P^2}\right) + H/12$
Internal threads						
Thread classes	Major diameter		Effective diameter		Minor diameter	
	Min.	Plus tolerance	Min.	Plus tolerance	Min.	Plus tolerance
1B	D	Not specified	E	$1.95\left(0.0015\sqrt[3]{D} + 0.0015\sqrt{L_e} + 0.015\sqrt[3]{P^2}\right)$	$D - 1\frac{1}{4}H$	$0.25P - 0.4P^2$ for 80 t.p.i. to 4 t.p.i. threads inclusive $0.15P$ for threads coarser than 4 t.p.i.
2B	D	Not specified	E	$1.3\left(0.0015\sqrt[3]{D} + 0.0015\sqrt{L_e} + 0.015\sqrt[3]{P^2}\right)$	$D - 1\frac{1}{4}H$	$0.25P - 0.4P^2$ for 80 t.p.i. to 4 t.p.i. threads inclusive $0.15P$ for threads coarser than 4 t.p.i.
3B	D	Not specified	E	$0.975\left(0.0015\sqrt[3]{D} + 0.0015\sqrt{L_e} + 0.015\sqrt[3]{P^2}\right)$	$D - 1\frac{1}{4}H$	$0.05\sqrt[3]{P^2} + 0.03P/D - 0.002$ Minimum: $0.23P - 1.5P^2$ for 80 t.p.i. to 13 t.p.i. and $0.12P$ for 12 t.p.i. and coarser.

NOTE 1 D = Basic major diameter.

E = Basic effective diameter = $D - \frac{3}{4}H$.

L_e = Length of engagement.

P = Pitch.

H = Height of fundamental triangle = $0.866\ 03P$.

G = Allowance = $0.3\left(0.0015\sqrt[3]{D} + 0.0015\sqrt{L_e} + 0.015\sqrt[3]{P^2}\right)$

NOTE 2 The above formulae relate to the limits of size of finished uncoated threads.

Figure A.1 Unified screw threads – Nomogram for effective (pitch) diameter tolerances, Class 2A

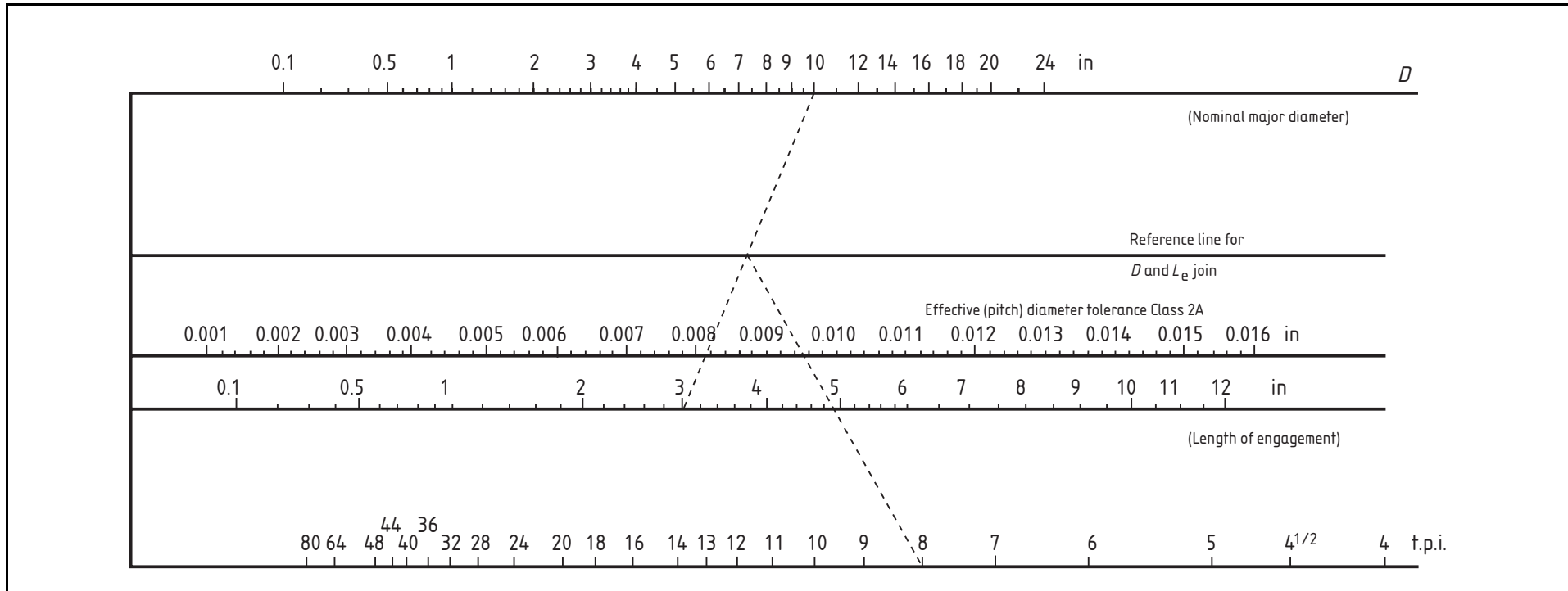

Dotted lines indicate method of use for a screw having the following characteristics:

$D = 10$ in, $L_e = 3$ in, 8 t.p.i.

$$\text{Class 2A effective diameter tolerance} = 0.0015\sqrt[3]{D} + 0.0015\sqrt{L_e} + 0.015\sqrt[3]{P^2}$$

Tolerance for Class 2A is 0.0096 in

Tolerances for other classes are as follows:

Class 1A = $1.5 \times$ tolerance for Class 2A

Class 1B = $1.95 \times$ tolerance for Class 2A

Class 2B = $1.3 \times$ tolerance for Class 2A

Class 3A = $0.75 \times$ tolerance for Class 2A

Class 3B = $0.975 \times$ tolerance for Class 2A

Allowance for Class 1A and Class 2A = $0.3 \times$ tolerance for Class 2A.

Annex B (informative) **Outline guide, and examples, for calculating limits of size of untabulated UNS screw threads**

B.1 General

Limits of size for untabulated UNS threads should be calculated in accordance with **B.2** or **B.3**, as applicable.

Except in the case of Class 2AG, use should be made wherever possible of Table 28 to Table 36. Where these are not applicable, the limits and tolerances should be calculated from the formulae given in Annex A.

NOTE Examples of calculations are given in **B.4**.

B.2 Uncoated external threads, Classes 1A, 2A and 3A

Limits of size should be calculated as follows.

Maximum major diameter

Classes 1A and 2A	= Basic major diameter (D) minus allowance (G), Table 28
Class 3A	= Basic major diameter (D)

Minimum major diameter

Class 1A	= Maximum, minus Class 1A tolerance, Table 29
Classes 2A and 3A	= Maximum, minus Classes 2A and 3A tolerance, Table 29

Maximum effective diameter

Classes 1A and 2A	= Basic effective diameter (E), minus allowance (G), Table 28
Class 3A	= Basic effective diameter (E)

Minimum effective diameter

Class 1A	= Maximum, minus Class 1A effective diameter tolerance, Table 30
Class 2A	= Maximum, minus Class 2A effective diameter tolerance, Table 31
Class 3A	= Maximum, minus Class 3A effective diameter tolerance, Table 32

Maximum minor diameter

All classes	= Maximum major diameter, minus $1\frac{5}{12}H$, Table 26, Column 14
-------------	--

Minimum minor diameter

All classes	= Maximum, minus (effective diameter tolerance for Class + $H/12$) Column 22 of Table 30, Table 31 or Table 32, for Classes 1A, 2A, and 3A respectively
-------------	--

B.3 Uncoated internal threads, Classes 1B, 2B and 3B

Limits of size should be calculated as follows.

<i>Minimum major diameter</i>	
All classes	= Basic major diameter (D)
<i>Maximum major diameter</i>	
All classes	Not specified
<i>Minimum effective diameter</i>	
All classes	= Basic effective diameter (E)
<i>Maximum effective diameter</i>	
Class 1B	= Minimum, plus Class 1B effective diameter tolerance, Table 33
Class 2B	= Minimum, plus Class 2B effective diameter tolerance, Table 34
Class 3B	= Minimum, plus Class 3B effective diameter tolerance, Table 35
<i>Minimum minor diameter</i>	
All classes	= Basic major diameter, minus $1\frac{1}{4}H$, Table 26, Column 13
<i>Maximum minor diameter</i>	
All classes	= Minimum, plus minor diameter tolerance, Table 36 (see Note)

NOTE Table 36 covers minor diameter tolerances for internal threads of practical diameter/pitch combinations. If the length of engagement (L_e) is less than $5P$ or greater than $15P$ reference should be made to Clause 7, Note 5, and if deemed necessary the limits should be adjusted accordingly.

B.4 Examples

The following examples are given to illustrate the method for determining the limits of size for untabulated threads.

Example 1 and Example 2 give examples for threads that are not to be coated and Example 3 gives an example for coated threads.

Example 1 and Example 3 are examples of UNS threads. Example 2 is of a thread that is not UNS but it has been included because the threads are untabulated and the limits of size therefore need to be calculated.

EXAMPLE 1

NOTE 1 Dimensions are in inches.

Description

Class 2A external thread, and Class 2B internal thread, $\frac{1}{4}$ in diameter \times 24 t.p.i. with a 0.25 in length of engagement.

NOTE 2 The fact that the description does not include a reference to coating means that the threads are not to be coated.

Basic sizes of thread

Major diameter	= 0.250 0
Effective diameter	= 0.250 0 – 0.027 1 = 0.222 9 (Table 26, Col. 12)
Minor diameter	= 0.250 0 – 0.045 1 = 0.204 9 (Table 26, Col. 13)

External thread

Design sizes:

Major diameter	= 0.250 0 – 0.001 1 = 0.248 9 (Table 28, Col. 2)
Effective diameter	= 0.222 9 – 0.001 1 = 0.221 8 (Table 28, Col. 2)
Minor diameter	= 0.248 9 – 0.051 1 = 0.197 8 (Table 26, Col. 14)

Tolerances:

Major diameter	= 0.007 2 (Table 29, Col. 3)
Effective diameter	= 0.003 7 (Table 31, Col. 3)
Minor diameter	= 0.003 7 + 0.003 0 = 0.006 7 (Table 31, Col. 22)

Limits:

Major diameter	= 0.248 9 and 0.241 7
Effective diameter	= 0.221 8 and 0.218 1
Minor diameter	= 0.197 8 and 0.191 1

Internal thread

Design sizes:

Major diameter	= 0.250 0
Effective diameter	= 0.222 9
Minor diameter	= 0.204 9

Tolerances:

Major diameter	no tolerance specified
Effective diameter	= 0.004 8 (Table 34, Col. 3)
Minor diameter	= 0.009 7 (Table 36, Col. 2)

Limits:

Major diameter	= 0.250 0 minimum
Effective diameter	= 0.222 9 and 0.227 7
Minor diameter	= 0.204 9 and 0.214 6

Thread designations $\frac{1}{4}$ — 24 UNS — 2A

Major diameter	= 0.2489 — 0.2417
Eff. diameter	= 0.2218 — 0.2181

 $\frac{1}{4}$ — 24 UNS — 2B

Minor diameter	= 0.2049 — 0.2146
Eff. diameter	= 0.2229 — 0.2277

EXAMPLE 2

NOTE 1 Dimensions are in inches.

Description

Class 1A external thread and Class 1B internal thread
4.5 in diameter \times 4 t.p.i. with a length of engagement of 0.75 in.

NOTE 2 Although this example is not of a UNS thread its limits of size need to be calculated. The thread is of a diameter and pitch which place it in the 4 UN series. However, the limits of size are not given in Table 2 because, firstly, the Class 1A and 1B limits are not given for this series and, secondly, the length of engagement is less than five pitches which precludes the use of the standard tolerances, the latter being based on a length of engagement of $4\frac{1}{2}$ in and being acceptable for lengths of engagement varying from $1\frac{1}{4}$ in to $6\frac{3}{4}$ in (5P to 1.5D).

Basic sizes of thread

Major diameter	= 4.500 0
Effective diameter	= 4.500 0 – 0.162 4 = 4.337 6 (Table 26, Col. 12)
Minor diameter	= 4.500 0 – 0.270 6 = 4.229 4 (Table 26, Col. 13)

External thread

Design sizes:

Major diameter	= 4.500 0 – 0.003 2 = 4.496 8 (Table 28, Col. 15)
Effective diameter	= 4.337 6 – 0.003 2 = 4.334 4 (Table 28, Col. 15)
Minor diameter	= 4.496 8 – 0.306 7 = 4.190 1 (Table 26, Col. 14)

Tolerances:

Major diameter	= 0.035 7 (Table 29, Column 2)
Effective diameter	= $1.5 \left(0.001 5 \sqrt[3]{4.5} + 0.001 5 \sqrt{0.75} + 0.015 \sqrt[3]{0.25^2} \right)$ (Table A.1) = 1.5(0.002 476 + 0.001 299 + 0.005 953) = 1.5(0.009 728) = 0.014 6 (see Note 3)

NOTE 3 This value can also be obtained using the nomogram in Figure A.1.

Minor diameter	= 0.014 6 + 0.018 0 = 0.032 6 (Table 30, Col. 22)
----------------	--

Limits:

Major diameter	= 4.496 8 and 4.461 1
Effective diameter	= 4.334 4 and 4.319 8
Minor diameter	= 4.190 1 and 4.157 5

Internal thread

Design sizes:

Major diameter = 4.500 0

Effective diameter = 4.337 6

Minor diameter = 4.229 4

Tolerances:

Major diameter no tolerance specified

Effective diameter = 1.95 (0.009 728) = 0.019 0

Minor diameter = 0.028 2 [Table 36, Col. 2 reduced by 25%
owing to the short length of engagement (L_e)
(see Clause 7, Note 5)]

Limits:

Major diameter = 4.500 0 minimum

Effective diameter = 4.337 6 and 4.356 6

Minor diameter = 4.229 4 and 4.257 6

Thread designations

4.5 — 4 UN — SE 1A

Major diameter = 4.4968 — 4.4611

Eff. diameter = 4.3344 — 4.3198 SPL

 $L_e = 0.75$

4.5 — 4 UN — SE 1B

Minor diameter = 4.2294 — 4.2576 SPL

Eff. diameter = 4.3376 — 4.3566 SPL

 $L_e = 0.75$ **EXAMPLE 3***NOTE Dimensions are in inches.***Description**Class 2AG external thread and Class 2B internal thread both having a coated finish, $\frac{1}{2}$ in diameter \times 20 t.p.i. with 0.44 in length of engagement.**Basic sizes of thread**

Major diameter = 0.500 0 (Table 16, Col. 2)

Effective diameter = 0.467 5 (Table 16, Col. 4)

Minor diameter = 0.445 9 (Table 16, Col. 6)

External thread

After-coating design sizes:

Major diameter = 0.498 7 (Table 11, Col. 2)

Effective diameter = 0.466 2 (Table 11, Col. 5)

Minor diameter = 0.437 4 (Table 11, Col. 8)

Before-coating design sizes (see Clause 9):

$$\text{Major diameter} = 0.498\ 7 - 0.001 = 0.497\ 7$$

$$\text{Effective diameter} = 0.466\ 2 - 0.001 = 0.465\ 2$$

$$\text{Minor diameter} = 0.437\ 4 - 0.001 = 0.436\ 4$$

Tolerances:

$$\text{Major diameter} = 0.008\ 1 \text{ (Table 11, Col. 4)}$$

$$\text{Effective diameter} = 0.004\ 3 \text{ (Table 11, Col. 7)}$$

$$\text{Minor diameter} = 0.007\ 9 \text{ (Table 11, Col. 10)}$$

Before-coating limits:

$$\text{Major diameter} = 0.497\ 7 \text{ and } 0.489\ 6$$

$$\text{Effective diameter} = 0.465\ 2 \text{ and } 0.460\ 9$$

$$\text{Minor diameter} = 0.436\ 4 \text{ and } 0.428\ 5$$

After-coating limits (minimum limits not specified):

$$\text{Major diameter} = 0.498\ 7 \text{ maximum}$$

$$\text{Effective diameter} = 0.466\ 2 \text{ maximum}$$

$$\text{Minor diameter} = 0.437\ 4 \text{ maximum}$$

Internal thread

After-coating design sizes:

$$\text{Major diameter} = 0.500\ 0$$

$$\text{Effective diameter} = 0.467\ 5$$

$$\text{Minor diameter} = 0.445\ 9$$

Before-coating design sizes [see Clause 9d):

$$\text{Major diameter} = 0.500\ 0 + 0.001 = 0.501\ 0$$

$$\text{Effective diameter} = 0.467\ 5 + 0.001 = 0.468\ 5$$

$$\text{Minor diameter} = 0.445\ 9 + 0.001 = 0.446\ 9$$

Tolerances:

$$\text{Major diameter} \text{ No tolerance specified}$$

$$\text{Effective diameter} = 0.005\ 6 - 0.001 = 0.004\ 6 \text{ (Table 12, Col. 7)}$$

$$\text{Minor diameter} = 0.011\ 5 - 0.001 = 0.010\ 5 \text{ (Table 12, Col. 4)}$$

Before-coating limits:

$$\text{Major diameter} = 0.501\ 0 \text{ minimum}$$

$$\text{Effective diameter} = 0.468\ 5 \text{ and } 0.473\ 1$$

$$\text{Minor diameter} = 0.446\ 9 \text{ and } 0.457\ 4$$

After-coating limits (maximum limits not specified):

$$\text{Major diameter} = 0.500\ 0 \text{ minimum}$$

$$\text{Effective diameter} = 0.467\ 5 \text{ minimum}$$

$$\text{Minor diameter} = 0.445\ 9 \text{ minimum}$$

Thread designations $\frac{1}{2}$ — 20 UNF — 2AG

Major diameter .4987 max.

Eff. diameter .4662 max. After coating

Major diameter .4977 — .4896 SPL

Eff. diameter .4652 — .4609 SPL Before coating

 $\frac{1}{2}$ — 20 UNF — 2B

Minor diameter .4459 min.

Eff. diameter .4675 min. After coating

Minor diameter .4469 — .4574 SPL

Eff. diameter .4685 — .4731 SPL Before coating

Annex C (informative) Forms of the crest of external threads

The actual form of the crest of an external unified thread depends on the method of manufacture.

If a single-ribbed grinding wheel or single-point cutting tool is used, a thread with a completely flat crest will be produced, as illustrated in Figure C.1a).

Use of a crushed multi-ribbed grinding wheel produces a crest profile as shown in Figure C.1b).

A typical form of crest produced by the thread rolling process is shown in Figure C.1c). The crests of threads resulting from this process will normally fall wholly above the minimum limiting profile shown in Figure 3.

Figure C.1d) shows the form of crest produced by a thread cutting die of nominal root radius, i.e. 0.108 *3P*. With a correctly formed tool there will be no serious loss of straight flank even when it cuts a thread on the minimum effective diameter as shown by Figure C.1d).

Provided that care is taken with regard to the wear of tools, rounded crests should rarely reach the dotted profile shown in Figure 3.

The following advantages are associated with bolts with rounded crests.

- a) Bolts with rounded crests are less susceptible than those having flat crests, to damage by burring during handling and transport, which results in sharp, or semi-sharp, edges round the outside diameter of the bolt.
- b) Troubles associated with plating are far less serious if the crests of the bolts are rounded. In the plating of bolts by the usual barrel plating process, the burring of flat-crested bolts can be quite serious, and in the still-vat process the plating tends to build up round the two edges at the outside diameter and encroaches upon the flanks.
- c) The threads on thread-rolling dies are stronger, less subject to fatigue failure and easier to grind if their roots are rounded rather than sharp-cornered.

Figure C.1 Crest profiles on external threads resulting from different production methods

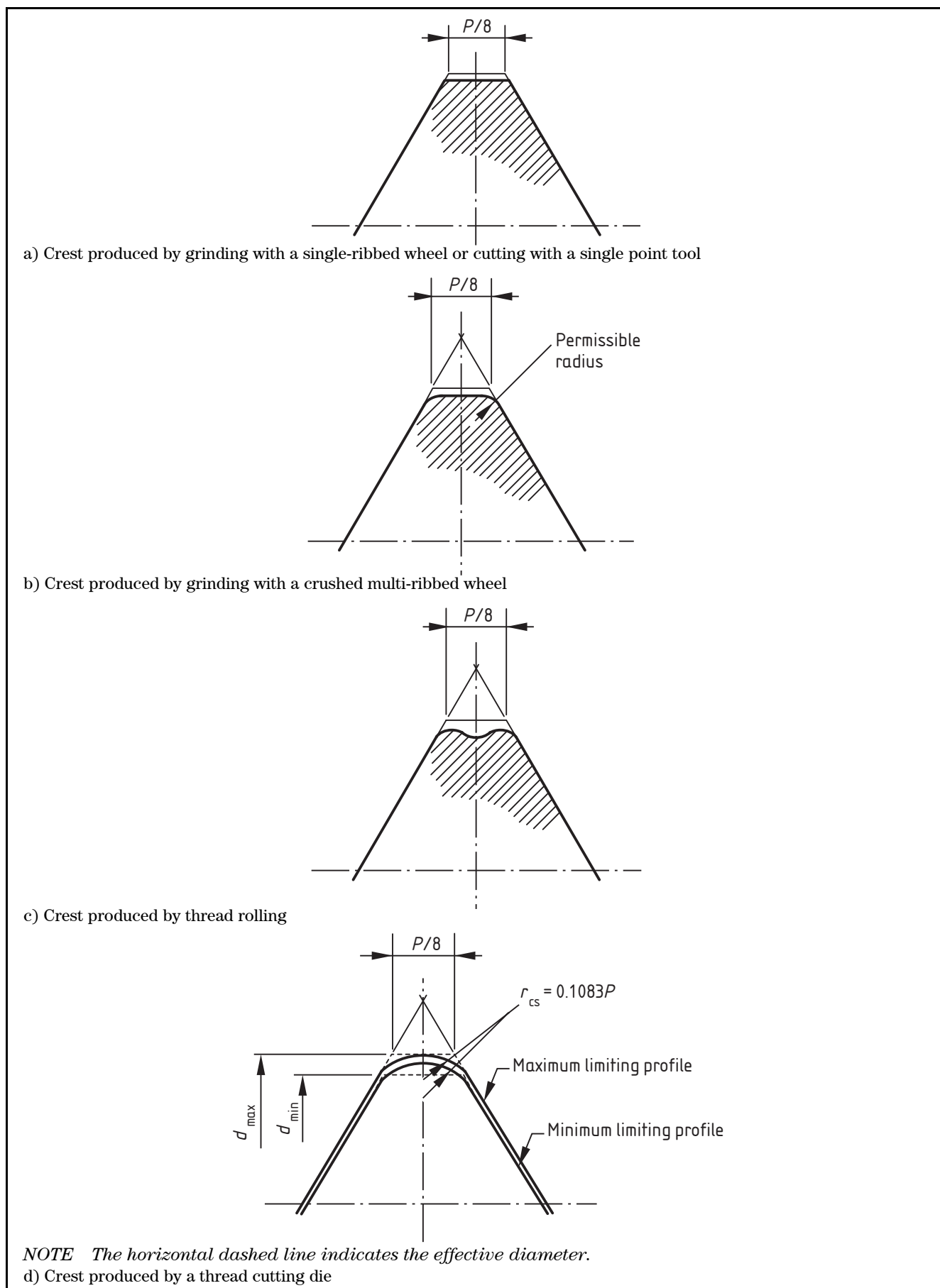

Annex D (informative) General symbols

General symbols are given in Table D.1 and illustrated in Figure D.1.

NOTE See 3.2.

Table D.1 General symbols

Symbol	Parameter	Remarks
A_s	Tensile stress area	$\frac{\pi}{4}(D - 0.938\ 20P)^2$
D	Basic major diameter	Subscripts s or n, indicating external or internal thread, may be used if necessary
E	Basic effective diameter	
K	Basic minor diameter	
P	Pitch	
l	Lead	
n	Number of threads per unit of length (per inch)	Equals $1/P$
N	Number of turns per unit of length (per inch)	Equals $1/l$
H	Height of fundamental triangle	
h	Height (or depth) of thread	Subscripts s or n, indicating external or internal thread, may be used if necessary
h_a	Addendum	$\tan \lambda = \frac{l}{\pi E}$
h_d	Dedendum	
h_b	Height of basic external thread	
h_e	Depth of thread engagement	
α	Half-angle of symmetrical thread	
α_1	Angle between leading flank of thread and normal to axis of thread	
α_2	Angle between following flank of thread and normal to axis of thread	
λ	Lead angle	
r_{rs}	Radius at root of external thread	
r_{cs}	Optional radius at crest of external thread	

Table D.1 General symbols (*continued*)

Symbol	Parameter	Remarks
	<i>Distance from apex of fundamental triangle to:</i>	
s	Root or crest of rounded thread (general)	
f	Root or crest of flat thread (general)	
f_{cs}	Flat at crest of external thread (general)	
s_{cs}	Rounded crest of external thread	
s_{rs}	Rounded root of external thread	
f_{cn}	Flat at crest of internal thread	
f_{rn}	Theoretical flat at root of internal thread	
F	Width of flat (general)	
F_{cs}	Width of flat at crest of external thread	
F_{cn}	Width of flat at crest of internal thread	
F_{rn}	Width of theoretical flat at root of internal thread	
L_e	Length of engagement	
Symbol prefixed with δ	Deviation in any dimension	Examples: Deviation in pitch, δP ; deviation in half-angle, $\delta\alpha_1$ or $\delta\alpha_2$
ΔE_α	Effective-diameter equivalent of deviations in flank angles	
ΔE_p	Effective-diameter equivalent of deviation in pitch	
G	Allowance	

Figure D.1 General symbols

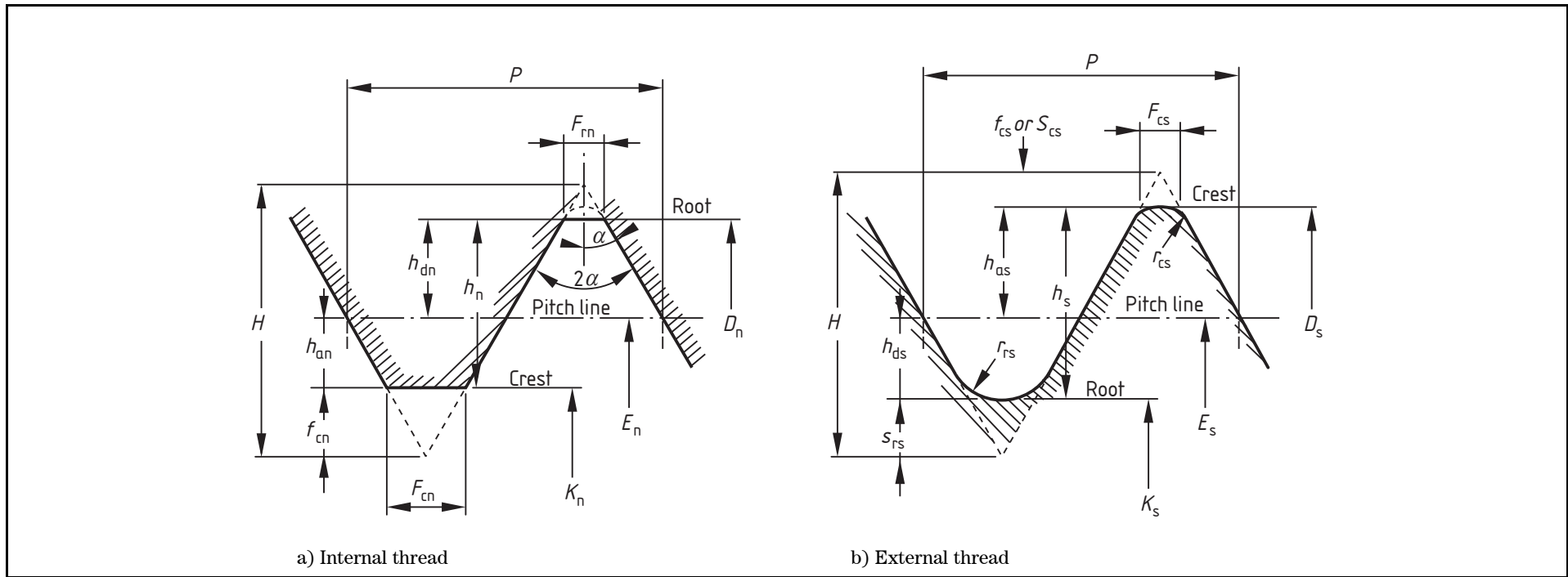

Annex E (informative)

Tolerances on pitch and flank angle in relation to tolerance on effective diameter

E.1 Effect of pitch errors

An error in pitch increases the effective diameter of an external thread and decreases the effective diameter of an internal thread. These increased or decreased effective diameters are termed virtual effective diameters (see 3.1.2). In the case of pitch errors, the difference, D_{ep} , in inches, between the simple effective diameter (see 3.1.1) and the virtual effective diameter is given by the following equation:

$$D_{ep} = 1.732 \times \delta P$$

where:

δP is the maximum error in the axial displacement between any two points on a unified form screw thread within the length of engagement, in inches.

E.2 Effect of errors in flank angle

An error in one or both of the flank angles increases the effective diameter of an external thread and decreases the effective diameter of an internal thread. These increased or decreased effective diameters are again virtual effective diameters (see E.1).

In the case of errors in flank angle(s), the difference, D_{ef} , in inches, between the simple effective diameter (see 3.1.1) and the virtual effective diameter is given by the following equation:

$$D_{ef} = 0.010 \times P \times (\delta\alpha_1 + \delta\alpha_2)$$

where:

P is the pitch of the thread;

$(\delta\alpha_1 + \delta\alpha_2)$ is the sum of the errors in the opposite flank angles, in degrees, *regardless of their signs*.

NOTE In the basic form of the unified screw thread the lengths of straight flank above and below the pitch line are not equal. For this reason the change in effective diameter resulting from positive flank angle errors on external threads and negative flank angle errors on internal threads will be slightly less than that resulting from negative flank angle errors on external threads and positive flank angle errors on internal threads. The factor of 0.010 in the expression above is the mean value of the corresponding factors applying to these two sets of conditions, and is sufficiently accurate for practical purposes.

E.3 Criteria for acceptability of a combination of errors in the effective diameter, pitch and flank angle of a screw thread

The simple effective diameter and virtual effective diameter of internal and external threads should be as follows.

- a) *External threads.* The simple effective diameter of an external thread (as measured along the pitch line of the thread) should lie between the limits specified for that diameter. In addition, the virtual effective diameter should not exceed the upper limit stated for the effective diameter.
- b) *Internal threads.* The simple effective diameter of an internal thread (as measured along the pitch line) should lie between the limits specified for that diameter. In addition, the virtual effective diameter should not be smaller than the lower limit stated for the effective diameter.

Experience has shown that when an external thread or an internal thread is inspected with a GO screw gauge made to the design size, and a NOT GO gauge for the effective diameter made to the lower limit for the effective diameter of the external thread or the upper limit for the effective diameter of the internal thread, the above conditions regarding the size of the “simple” effective diameter (see 3.1.1), and its size as influenced by any errors in the pitch and flank angle of the thread, are safeguarded for practical purposes.

E.4 Tolerances on pitch and flank angle of a screw thread

It is not possible to lay down definite tolerances for the pitch or the flank angle of a screw thread of any particular size or class. In any particular case, the maximum permissible combined effects of pitch and flank angle errors will depend upon the difference between the “simple” effective diameter of the external or internal thread and the design size of the effective diameter. In the case of an external thread having its simple effective diameter on the upper limit, i.e. equal to the design size of the effective diameter, no errors at all can be allowed in pitch or flank angle. The combined effect of the errors in pitch and flank angle can only be permitted to reach a maximum value in the case of an external thread the simple effective diameter of which is on its lower limit, or in the case of an internal thread the simple effective diameter of which is on the upper limit specified.

It is important to realize that the tolerance allowed on the effective diameter of an external or an internal thread should not be regarded as being available in full for variations in that element of the thread alone; part of this tolerance should be considered as reserved for compensating for the effects of errors in pitch and flank angle, which are invariably present to some extent.

Annex F (informative) **Standard unified thread series, guidance on selection and use**

F.1 General

The characteristics of the different series of standard unified screw threads and the uses for which they are suitable are given in **F.2** to **F.5**. In selecting the thread for a particular use the strength of the thread should also be taken into account. Guidance on the strengths of threads is given in BS 3580.

F.2 Coarse thread series (UNC)

This series is suitable for the bulk production of bolts, screws, and nuts and for other general engineering purposes. The coarse pitch gives a good resistance to stripping. The series is suitable for use with lower tensile strength materials such as cast iron, mild steel and softer materials (brass, aluminium, plastics, etc.). It is suitable for components needing rapid assembly or removal, or if corrosion or slight damage is likely.

F.3 Fine thread series (UNF)

This series is suitable for use where a finer pitch is needed. It is less resistant to stripping, and to the effects of repeated tightening than the coarse series. It is not recommended for high-duty fasteners above 1 in diameter, but provided that the length of engagement is adequate, it can be expected to give sufficient resistance to stripping to develop the full tensile load carrying capacity of the externally threaded member; and subject to the same provisions can be used satisfactorily in softer materials. The external threads of this series have a greater tensile stress area than those of the coarse series.

This series has finer pitches than those in the Whitworth fine series (B.S.F.) (see BS 84). Therefore it should not be assumed that, size for size, it is always suitable for particular uses for which the B.S.F. series has previously been employed; quite often the UNC series would be more appropriate.

F.4 Extra fine thread series (UNEF)

This series is convenient for use where finer pitches are required for short lengths of engagement and for thin walled designs. It has been extensively used in the past in the United States of America and is convenient for designs in which interchangeability with United States practice is important. For use in the UK, threads in this series above 1 in diameter are not recommended. For diameters above 1 in, the 20 UN series is recommended in preference to the 18 t.p.i. of the UNEF series.

F.5 Constant pitch series

These constant pitch series are intended for general design work, for which the variable pitch series are unsuitable or inadequate. The intended uses of these thread series are as follows.

- a) *4-Thread series (4 UN)*. This series is intended for use where a very robust thread is needed.
- b) *6-Thread series (6 UN)*. This series offers a robust thread which can be used for heavy duty applications where space is limited.
- c) *8-Thread series (8 UN)*. This series, originally used for high-pressure joint bolts and nuts, is now widely used in the United States of America instead of the UNC series above 1 in. It is generally recommended for use in moderate to large designs in which a reasonably fine thread is desirable. It is suitable for bolts and nuts for high temperature work.
- d) *12-Thread series (12 UN)*. This series was originally devised for boiler practice to permit tapping out worn threads one size larger. It is a very convenient series when a medium fine pitch is needed on moderate to large diameters, and in compact designs, since the double depth of thread falls within $\frac{1}{8}$ in increments of basic size on diameter.
- e) *16-Thread series (16 UN)*. This series gives a convenient and reasonably robust thread for use on large diameters in compact designs.
- f) *20-Thread series (20 UN)*. This series provides a very convenient fine thread for compact designs of moderate diameter as the double depth of thread falls within $\frac{1}{16}$ in increments of basic size on diameter.
- g) *28-Thread and 32-Thread series (28 UN and 32 UN)*. These series are intended for use on small to moderate diameters in designs for which the 20 UN series is too coarse.

Annex G (informative)

Standard unified thread series, information and guidance regarding the tolerance classes

G.1 Classes 2A and 2B

Classes 2A and 2B, which correspond substantially to the Whitworth “medium” class of external thread and the “normal” class of internal thread (see BS 84), are the classes suitable for the majority of general engineering purposes.

The allowance on Class 2A threads assists in free assembly, and thus minimizes galling and seizing in high speed assembly. It also provides a definite minimum clearance for the application of a suitable lubricant in some types of assembly, such as high temperature bolting [see F.5c)], for which however, it may sometimes be necessary to increase the allowance while maintaining the Class 2A tolerance.

In the case of coated Class 2A threads, the difference between the maximum material limits and the basic size, constituted by the allowance, is permitted to be taken up by the thickness of the coating [see Clause 9b)].

G.2 Classes 3A and 3B

Classes 3A and 3B are classes of threads requiring a closer fit than that normally obtained with Classes 2A and 2B, and should only be used when close accuracy of thread form and pitch is particularly required. Classes 3A and 3B correspond substantially to the Whitworth “close” class of external thread and the “medium” class of internal thread. Consistent production of threads of Classes 3A and 3B requires the use of high quality production equipment and particularly thorough inspection.

Class 3A threads have no allowance. When these threads are coated, adjustments have to be made to their normal limits to suit the pre-coating conditions, as specified in Clause 9d).

NOTE Owing to the tendency for close-fitting external and internal threads made of stainless steel to seize when tightened together, it is recommended that stainless steel external threads should not be made to Class 3A limits but rather to Class 1A or Class 2A limits for uncoated external threads.

G.3 Classes 1A and 1B

Threads of Classes 1A and 1B are primarily intended for applications in which quick and easy assembly is needed even when the threads have become dirty or slightly damaged.

The allowance on Class 1A threads is the same as for Class 2A so that in the case of uncoated threads, the closest fit obtainable is the same, but the larger tolerances result in a freer average fit with Classes 1A and 1B threads. The allowance on Class 1A threads has to be maintained after coating [see Clause 9a)]. In the ordinary range of fasteners, Class 1B nuts are not widely used. A Class 2B nut associated with a Class 1A bolt is likely to be suitable for most purposes requiring a free fit. The Class 1A/1B fit is freer than the Whitworth “free”/“normal” fit.

Bibliography

Standards publications

For dated references, only the edition cited applies. For undated references, the latest edition of the referenced document (including any amendments) applies.

BS 2693-1, *Specification for screwed studs – Part 1: General purpose studs*

BS 2693-2, *Specification for screwed studs – Part 2: Recommendations for high grade studs*

BS 3382: Parts 1 & 2, *Specification for electroplated coatings on threaded components – Part 1: Cadmium on steel components – Part 2: Zinc on steel components*

BS 3382-7, *Specification for electroplated coatings on threaded components – Part 7: Thicker platings for threaded components*

BS 3580, *Guide to design considerations on the strength of screw threads*

BS ISO 68-2:1998, *ISO general purpose screw threads – Basic profile – Part 2: Inch screw threads*

ASME B1.1-2003, *Unified inch screw threads (UN and UNR thread form)*

BSI – British Standards Institution

BSI is the independent national body responsible for preparing British Standards. It presents the UK view on standards in Europe and at the international level. It is incorporated by Royal Charter.

Revisions

British Standards are updated by amendment or revision. Users of British Standards should make sure that they possess the latest amendments or editions.

It is the constant aim of BSI to improve the quality of our products and services. We would be grateful if anyone finding an inaccuracy or ambiguity while using this British Standard would inform the Secretary of the technical committee responsible, the identity of which can be found on the inside front cover.

Tel: +44 (0)20 8996 9000. Fax: +44 (0)20 8996 7400.

BSI offers members an individual updating service called PLUS which ensures that subscribers automatically receive the latest editions of standards.

Buying standards

Orders for all BSI, international and foreign standards publications should be addressed to Customer Services. Tel: +44 (0)20 8996 9001.

Fax: +44 (0)20 8996 7001. Email: orders@bsi-global.com. Standards are also available from the BSI website at <http://www.bsi-global.com>.

In response to orders for international standards, it is BSI policy to supply the BSI implementation of those that have been published as British Standards, unless otherwise requested.

Information on standards

BSI provides a wide range of information on national, European and international standards through its Library and its Technical Help to Exporters Service. Various BSI electronic information services are also available which give details on all its products and services. Contact the Information Centre. Tel: +44 (0)20 8996 7111. Fax: +44 (0)20 8996 7048. Email: info@bsi-global.com.

Subscribing members of BSI are kept up to date with standards developments and receive substantial discounts on the purchase price of standards. For details of these and other benefits contact Membership Administration. Tel: +44 (0)20 8996 7002. Fax: +44 (0)20 8996 7001. Email: membership@bsi-global.com.

Information regarding online access to British Standards via British Standards Online can be found at <http://www.bsi-global.com/bsonline>.

Further information about BSI is available on the BSI website at <http://www.bsi-global.com>.

Copyright

Copyright subsists in all BSI publications. BSI also holds the copyright, in the UK, of the publications of the international standardization bodies. Except as permitted under the Copyright, Designs and Patents Act 1988 no extract may be reproduced, stored in a retrieval system or transmitted in any form or by any means – electronic, photocopying, recording or otherwise – without prior written permission from BSI.

This does not preclude the free use, in the course of implementing the standard, of necessary details such as symbols, and size, type or grade designations. If these details are to be used for any other purpose than implementation then the prior written permission of BSI must be obtained.

Details and advice can be obtained from the Copyright & Licensing Manager.

Tel: +44 (0)20 8996 7070. Fax: +44 (0)20 8996 7553.

Email: copyright@bsi-global.com.



389 Chiswick High Road
London
W4 4AL