

Methods of test for

Soils for civil engineering purposes —

Part 2: Classification tests

Confirmed
January 2010

Committees responsible for this British Standard

The preparation of this British Standard was entrusted by the Road Engineering Standards Policy Committee (RDB/-) to Technical Committee RDB/38, upon which the following bodies were represented:

Association of Consulting Engineers
 British Civil Engineering Test Equipment Manufacturers' Association
 County Surveyors' Society
 Department of the Environment (Property Services Agency)
 Department of the Environment (Building Research Establishment)
 Department of Transport
 Department of Transport (Transport and Road Research Laboratory)
 Coopted members

This British Standard, having been prepared under the direction of the Road Engineering Standards Policy Committee, was published under the authority of Board of the BSI and comes into effect on
 31 August 1990

© BSI 11-1998

The following BSI references relate to the work on this standard:
 Committee reference RDB/38
 Draft for comment 88/10675 DC

ISBN 0 580 17867 6

Amendments issued since publication

Amd. No.	Date of issue	Comments
9027	May 1996	Indicated by a sideline in the margin

Contents

	Page
Committees responsible	Inside front cover
Foreword	ii
<hr/>	
1 Scope	1
2 Definitions	1
3 Determination of moisture content	1
3.1 General	1
3.2 Oven-drying method	1
3.3 Method for saturation moisture content of chalk	3
4 Determination of the liquid limit	4
4.1 General	4
4.2 Sample preparation	4
4.3 Cone penetrometer method (definitive method)	5
4.4 One-point cone penetrometer method	8
4.5 Casagrande apparatus method	9
4.6 One-point Casagrande method	11
5 Determination of the plastic limit and plasticity index	13
5.1 General	13
5.2 Sample preparation	13
5.3 Method for plastic limit	13
5.4 Derivation of plasticity index and liquidity index	14
6 Determination of shrinkage characteristics	14
6.1 General	14
6.2 Sample preparation	14
6.3 Volumetric shrinkage (definitive method)	15
6.4 Volumetric shrinkage (subsidiary method)	18
6.5 Linear shrinkage	21
7 Determination of density	23
7.1 General	23
7.2 Linear measurement method	23
7.3 Immersion in water method	24
7.4 Water displacement method	26
8 Determination of particle density	28
8.1 General	28
8.2 Gas jar method	28
8.3 Small pyknometer method	29
8.4 Large pyknometer method	31
9 Determination of particle size distribution	32
9.1 General	32
9.2 Wet sieving method	32
9.3 Dry sieving method	36
9.4 Sedimentation by the pipette method	37
9.5 Sedimentation by the hydrometer method	42
<hr/>	
Appendix A Typical test data and calculation forms	50
Figure 1 — Details of cone for liquid limit test	7
Figure 2 — Casagrande liquid limit apparatus	10
Figure 3 — Grooving tool and height gauge	10
Figure 4 — Shrinkage limit apparatus	15
Figure 5 — Typical shrinkage curve	17

	Page
Figure 6 — Apparatus for shrinkage limit test	20
Figure 7 — Mould for linear shrinkage test	22
Figure 8 — Apparatus for determination of density by immersion in water	25
Figure 9 — Apparatus for determination of density by water displacement	26
Figure 10 — Minimum mass of sample required for particle size test	33
Figure 11 — Sampling pipette for sedimentation test	37
Figure 12 — Arrangement for lowering sampling pipette into soil suspension	38
Figure 13 — Hydrometer for determination of fine particle size	43
Figure 14 — Essential measurements for calibration of hydrometer	45
<hr/>	
Table 1 — Factors for one-point cone penetrometer liquid limit test	9
Table 2 — Factors for one-point Casagrande liquid limit test	13
Table 3 — Mass of soil sample for sieving	34
Table 4 — Maximum mass of material to be retained on each test sieve at the completion of sieving	34
Table 5 — Pipette sampling times and equivalent particle diameters	41
Table 6 — Hydrometer test data	48
Table 7 — Viscosity of water	49
<hr/>	
Publications referred to	Inside back cover

Foreword

This Part of BS 1377 has been prepared under the direction of the Road Engineering Standards Policy Committee. It is a revision of clause 2 of BS 1377:1975 which is superseded by amendment.

BS 1377:1975 which has now been withdrawn is replaced by the following Parts of BS 1377:1990:

- *Part 1: General requirements and sample preparation;*
- *Part 2: Classification tests;*
- *Part 3: Chemical and electro-chemical tests;*
- *Part 4: Compaction-related tests;*
- *Part 5: Compressibility, permeability and durability tests;*
- *Part 6: Consolidation and permeability tests in hydraulic cells and with pore pressure measurement;*
- *Part 7: Shear strength tests (total stress);*
- *Part 8: Shear strength tests (effective stress);*
- *Part 9: In-situ tests.*

Reference should be made to Part 1 for further information about each of the Parts.

The principal changes to the classification tests as described in the 1975 edition are as follows.

a) *Additions*

- Determination of the saturation moisture content of chalk.
- Determination of the liquid limit by a one-point cone penetration test.
- Determination of shrinkage limit.
- Determination of bulk density by direct measurement of an undisturbed sample.
- Determination of particle density using a large pycnometer (preserving jar).

b) *Deletion*

- The alcohol and sand bath methods for the determination of moisture content.

c) *Significant changes*

- Use of the ISO recommended series of sieve aperture sizes has been introduced as an alternative to existing sieve aperture sizes.

Procedures for fine particle size analysis by sedimentation have been amended. Pretreatment is not now mandatory, and the need for several corrections to test observations has been eliminated.

The term “particle density” replaces “specific gravity”.

For most of the tests the normal requirement is to use the soil in its natural state without the need for drying before testing.

It has been assumed in the drafting of this British Standard that the execution of its provisions is entrusted to appropriately qualified and experienced people.

A British Standard does not purport to include all the necessary provisions of a contract. Users of British Standards are responsible for their correct application.

Compliance with a British Standard does not of itself confer immunity from legal obligations.

Summary of pages

This document comprises a front cover, an inside front cover, pages 1 to 64, an inside back cover and a back cover.

This standard has been updated (see copyright date) and may have had amendments incorporated. This will be indicated in the amendment table on the inside front cover.

1 Scope

This Part of BS 1377 specifies methods of test for the classification of soil and for the determination of basic physical properties.

Most of these tests are required for the classification of soils in accordance with BS 5930:1981.

Some of the properties determined by these tests are required for tests described in other Parts of this standard.

Reference should be made to Part 1 of this standard for general requirements that are relevant to all Parts of this standard, and for methods of preparation of samples for testing.

NOTE The titles of the publications referred to in this standard are listed on the inside back cover.

2 Definitions

For the purposes of this Part of BS 1377 the definitions given in BS 1377-1 apply.

3 Determination of moisture content

3.1 General

Water is present in most naturally occurring soils. The amount of water, expressed as a proportion by mass of the dry solid particles, known as the moisture content, has a profound effect on soil behaviour. In this context a soil is “dry” when no further water can be removed at a temperature not exceeding 110 °C.

Moisture content is required as a guide to classification of natural soils and as a control criterion in recompacted soils and is measured on samples used for most field and laboratory tests. The oven-drying method is the definitive procedure used in standard laboratory practice.

NOTE In some situations, for example in the field control of earthworks, a rapid method of measurement of moisture content may be required and a number of rapid methods are available, e.g. the sand bath method, the microwave oven-drying method and the calcium carbide method. It should not be assumed that these methods are appropriate for all soil types and when they are used on a particular soil some tests should also be carried out using the oven-drying method as a check.

A procedure for determining the moisture content at full saturation of chalk is described.

3.2 Oven-drying method

3.2.1 General. This method covers the determination of the moisture content of a specimen of soil as a percentage of its dry mass.

The requirements of Part 1 of this standard, where appropriate, shall apply to this test method.

3.2.2 Apparatus

3.2.2.1 A *drying oven*, capable of maintaining a temperature of 105 °C to 110 °C.

NOTE A microwave oven should not be used for the determination of moisture content by the definitive method for soils containing clay or organic matter because of the difficulty of ensuring that the temperature of the soil does not exceed 110 °C before all the water is removed. Higher temperatures than this can alter the properties of clay material.

3.2.2.2 For *fine-grained soils*

3.2.2.2.1 A *glass weighing bottle*, fitted with a ground glass stopper or cap, or a suitable airtight corrosion-resistant metal container.

3.2.2.2.2 A *balance* readable to 0.01 g.

3.2.2.2.3 A *desiccator* containing anhydrous silica gel.

NOTE It is preferable to use self-indicating silica gel as the desiccant. Calcium chloride should not be used as it is known that many clays when oven dry are capable of absorbing water from it.

3.2.2.3 For *medium-grained soils*

3.2.2.3.1 A *corrosion-resistant container* of about 500 g capacity.

3.2.2.3.2 A *balance* readable to 0.1 g.

3.2.2.3.3 A *scoop* of suitable size.

3.2.2.4 For *coarse-grained soils*

3.2.2.4.1 A *corrosion-resistant container* of about 4 kg capacity.

3.2.2.4.2 A *balance* readable to 1 g.

3.2.2.4.3 A *scoop* of suitable size.

3.2.3 Procedure

3.2.3.1 For *fine-grained soils*

3.2.3.1.1 Clean and dry the weighing bottle or metal container and weigh it to the nearest 0.01 g (m_1). Take a sample of at least 30 g of soil, crumble and place loosely in the container or weighing bottle, and replace the lid or stopper. Then weigh the container or bottle and contents to the nearest 0.01 g (m_2).

3.2.3.1.2 Remove the lid or stopper, and place the container or bottle with its lid and contents in the oven and dry at 105 °C to 110 °C. The period required for drying will vary with the type of soil and the size of sample but the sample shall be deemed to be dry when the differences in successive weighings of the cooled sample (see **3.2.3.1.3** and **3.2.3.1.4**) at intervals of 4 h do not exceed 0.1 % of the original mass of the sample. Do not replace the lid or stopper while the sample is in the oven.

NOTE 1 Certain soils contain gypsum which on heating loses its water of crystallization. The moisture content determined by this method will be affected by approximately 0.2 % for each 1 % of gypsum. If it is suspected that gypsum is present in the soil the moisture content samples should be dried at no more than 80 °C and possibly for a longer time. The presence of gypsum can be identified by heating a small quantity of soil on a metal plate. Grains of gypsum will turn white within a few minutes, whereas most other mineral grains remain unaltered.

NOTE 2 Between 16 h and 24 h is usually a sufficient length of time for drying most soils, but certain soil types and large or very wet samples will require longer. The drying time will also depend on the amount of material in the oven and may be confirmed by trial tests.

3.2.3.1.3 After drying, remove the container or bottle and contents from the oven and place the whole in the desiccator to cool.

NOTE If the lids of the containers fit well and it is unlikely that the samples are to be left for a considerable time before weighing, the samples need not be placed in the desiccator to cool, unless glass weighing bottles with ground glass stoppers have been used.

3.2.3.1.4 Replace the lid and then weigh the container or bottle and contents to the nearest 0.01 g (m_3).

3.2.3.2 For medium-grained soils

3.2.3.2.1 Clean and dry the container and weigh it to the nearest 0.1 g (m_1). Take a sample of at least 300 g of soil, crumble and place loosely in the container, and replace the lid. Then weigh the container and contents to the nearest 0.1 g (m_2).

3.2.3.2.2 Remove the lid and place the container and contents in the oven and dry at 105 °C to 110 °C (see note 1 to **3.2.3.1.2**). The period required for drying will vary with the type of soil, the size of sample and the number of samples in the oven but the sample shall be deemed to be dry when the differences in successive weighings of the cooled sample (see **3.2.3.2.3** and **3.2.3.2.4**) at intervals of 4 h do not exceed 0.1 % of the original mass of the soil (see note 2 to **3.2.3.1.2**). Do not replace the lid while the sample is in the oven.

3.2.3.2.3 After drying, replace the lid and allow the whole to cool.

3.2.3.2.4 Weigh the container and contents to the nearest 0.1 g (m_3).

3.2.3.3 For coarse-grained soils

3.2.3.3.1 Clean and dry the container and weigh it to the nearest 1 g (m_1). Take a sample of at least 3 kg of soil, place loosely in the container and replace the lid. Weigh the container and contents to the nearest 1 g (m_2).

3.2.3.3.2 Remove the lid and place the container and contents in the oven and dry at 105 °C to 110 °C (see note 1 to **3.2.3.1.2**). The period for drying will vary with the type of soil and the size of the sample but the sample shall be deemed to be dry when the differences in successive weighings of the cooled sample (see **3.2.3.3.3** and **3.2.3.3.4**) at intervals of 4 h do not exceed 0.1 % of the original mass of the soil (see note 2 to **3.2.3.1.2**). Do not replace the lid while the sample is in the oven.

3.2.3.3.3 After drying, replace the lid and allow the whole to cool.

3.2.3.3.4 Weigh the container and contents to the nearest 1 g (m_3).

3.2.4 Calculations and expression of results
(See form 2.A of appendix A.)

Calculate the moisture content of the soil specimen, w , as a percentage of the dry soil mass to the nearest 0.1 %, from the equation:

$$w = \left(\frac{m_2 - m_3}{m_3 - m_1} \right) 100 \text{ (\%)}$$

where

m_1 is the mass of container (in g);

m_2 is the mass of container and wet soil (in g);

m_3 is the mass of container and dry soil (in g).

NOTE 1 If the moisture content is to be related to the Atterberg limits, e.g. for determining the liquidity index, and the soil contains material retained on a 425 µm sieve, the measured moisture content, w (in %), can be corrected to give the equivalent moisture content, w_a (in %), of the fraction passing the 425 µm sieve, using the equation:

$$w_a = w \left(\frac{100}{p_a} \right)$$

where

P_a is the percentage by dry mass of the portion of the soil sample passing the 425 µm test sieve, determined as specified in **4.2.4** and **4.2.5**.

If the particles retained on the 425 µm sieve are porous and absorb water, the amount of absorption should be determined and the value of w_a calculated from the equation.

$$w_a = \frac{100}{p_a} w - w_r \left(\frac{100 - p_a}{p_a} \right)$$

where

w_r is the moisture content of the fraction retained on the 425 µm test sieve.

NOTE 2 The presence of dissolved salts in saline water gives an incorrect value of moisture content. For these soils the "fluid content" is more appropriate, i.e. the mass of pore fluid (water plus salts) per unit dry mass of soil particles. This can be calculated from the measured moisture content, w (in %), by the following two ways.

a) If the proportion by mass of salt in the fluid is known (p parts per thousand (ppt), i.e. p in mg of salt per g of fluid), the fluid content, w_f (in %), by mass is calculated from the equation:

$$w_f = \frac{1000 w}{1000 - p \left(1 + \frac{w}{100} \right)}$$

b) If the salt content is known in terms of volume (q in g of salt per litre of fluid), the density of the fluid, ρ_f (in Mg/m³), also needs to be known. The fluid content (in %) by volume can then be calculated from the equation:

$$w_f = \frac{1000 w}{1000 - \frac{q}{\rho_f} \left(1 + \frac{w}{100} \right)}$$

In sea water having a density of 1.024 Mg/m³ and containing a salt concentration of 35 ppt by mass, the difference between the fluid content and the conventional moisture content, expressed as a percentage, is about 3 %. The difference increases with increasing moisture content.

If the salt concentration in the water is not known it can be determined by the method given in clause 8 of BS 1377-3:1990.

Express the moisture content of the soil for values up to 10 % to two significant figures. For moisture contents above 10 % express the result to the nearest whole number.

3.2.5 Test report. The test report shall affirm that the test was carried out in accordance with BS 1377-2:1990 and shall contain the following information:

- a) the method of test used;
- b) the moisture content;
- c) the temperature at which the soil was dried, if less than 105 °C;
- d) the comparison with Atterberg limits, if required (see note 1 to 3.2.4);
- e) the fluid content, if appropriate (see note 2 to 3.2.4);
- f) the information required by clause 9 of BS 1377-1:1990.

3.3 Method for saturation moisture content of chalk

3.3.1 General. The saturation moisture content of intact chalk lumps can be used, together with the chalk crushing value, to classify chalk in relation to its behaviour as a freshly placed fill material. This test is based on the determination of the dry density of the chalk lump, using the "Immersion in water method", and the calculation from it of the potential moisture content at saturation, assuming a value of 2.70 Mg/m³ for the particle density of the chalk solids.

The requirements of Part 1 of this standard, where appropriate, shall apply to this test method.

3.3.2 Apparatus

3.3.2.1 A metal or plastics watertight container

3.3.2.2 A balance readable to 1 g.

3.3.2.3 A cradle and supporting frame similar in principle to that shown in Figure 8 which, with the frame attached to the scoop or platform of the balance, can support the cradle below the balance.

NOTE The arrangement of the cradle and supporting frame shown in Figure 8 has been found convenient but any other method which enables the specimen to be suspended in water, supported only by the scoop or platform of the balance above, would also be satisfactory. Adequate counterbalance weights should be placed on the supporting battens.

3.3.2.4 Equipment for melting paraffin wax, preferably thermostatically controlled.

3.3.2.5 Apparatus for moisture content determination as specified in 3.2.

3.3.3 Material. Paraffin wax as specified in 5.4.2 of Part 1 of this standard.

3.3.4 Adjustment of apparatus

3.3.4.1 Support the balance with the scoop or platform over the container and with at least 300 mm clear space between the underside of the supports and the top of the container. A suitable arrangement is shown in Figure 8.

3.3.4.2 Fill the container with water to within about 80 mm of the top. Then place it in a position below the balance, and adjust the cradle and supporting frame, so that the cradle is suspended in the water without touching either the bottom or the sides of the container. Ensure that the largest specimen to be tested will be immersed completely when on the cradle.

3.3.4.3 Place a counter-mass on the scale pan to bring the reading on the balance back to zero if necessary.

3.3.5 Procedure

3.3.5.1 Each sample to be tested shall consist of an intact lump of chalk, with a volume between 300 mL and 500 mL. Weigh the sample to the nearest 1 g (m_s).

3.3.5.2 Coat the specimen completely by repeated dipping in molten paraffin wax. Allow the waxed specimen to cool and weigh to the nearest 1 g (m_w).

NOTE 1 Waxing of the specimen should be carried out very carefully. Surface depressions, including cavities left by stones, should be first coated with molten wax applied by brush, and allowed to set before dipping. Ensure that air bubbles are not formed under the wax. Cavities considered to be parts of existing voids, e.g. in compacted soils, due to poor compaction, should be made up with filler before waxing.

NOTE 2 To avoid shrinking and cracking of the wax coating, the wax should be only just molten when applied. In the absence of a thermostatically controlled wax pot, use of a carpenter's glue pot helps to avoid overheating of the wax.

3.3.5.3 Place the waxed specimen in the cradle and suspend the cradle from the supporting frame attached to the scoop or platform of the balance. Record the apparent mass of the specimen while suspended in water to the nearest 1 g (m_g).

NOTE When the specimen is placed in the water, supported by the cradle, care should be taken to see that no air bubbles are trapped underneath the specimen. Also, while measuring the apparent mass when suspended in water, it should be ensured that the specimen is immersed completely. If this is not the case either the level of the water in the container should be raised or the supporting frame should be adjusted until the specimen is immersed completely. The specimen should then be removed from the cradle and the apparatus readjusted as specified in 3.3.4.2 and 3.3.4.3.

3.3.5.4 Remove the specimen from the cradle and carefully remove the paraffin wax. Determine the moisture content of the whole specimen, using the procedure specified in 3.2.

3.3.6 Calculations and expression of results (See form 2.B of appendix A.)

Calculate the volume of the test specimen, V_s (in cm^3), from the equation:

$$V_s = (m_w - m_g) - \frac{(m_w - m_s)}{\rho_p}$$

where

m_w is the mass of specimen and wax coating (in g);

m_g is the apparent mass of specimen and wax coating when suspended in water (in g);

m_s is the mass of the chalk specimen (in g);

ρ_p is the density of paraffin wax (in Mg/m^3).

NOTE The density of the wax can be determined by procedure 1 described in 7.2.

Calculate the bulk density of the specimen, ρ (in Mg/m^3), from the equation:

$$\rho = \frac{m_s}{v_s}$$

Calculate the dry density of the specimen, ρ_d (in Mg/m^3), from the equation:

$$\rho_d = \frac{100 \rho}{100 + w}$$

where

w is the moisture content of the chalk (in %)

Calculate the saturation moisture content, w_s (in %), from the equation:

$$w_s = 100 \left(\frac{1}{\rho_d} - \frac{1}{2.7} \right)$$

where

2.7 is the particle density of the chalk (in Mg/m^3).

Express the saturation moisture content for values up to 10 % to two significant figures. For saturation moisture contents above 10 % express the result to the nearest whole number.

3.3.7 Test report. The test report shall affirm that the test was carried out in accordance with BS 1377-2:1990 and shall contain the following information:

- the method of test used;
- the saturation moisture content;
- the information required by clause 9 of BS 1377-1:1990.

4 Determination of the liquid limit

4.1 General

The liquid limit is the empirically established moisture content at which a soil passes from the liquid state to the plastic state. It provides a means of classifying a soil, especially when the plastic limit (see clause 5) is also known.

Two main types of test are specified. The first is the cone penetrometer method, which is fundamentally more satisfactory than the alternative because it is essentially a static test depending on soil shear strength. It is also easier to perform and gives more reproducible results. The second is the much earlier Casagrande type of test which has been used for many years as a basis for soil classification and correlation of engineering properties. This test introduces dynamic effects and is more susceptible to discrepancies between operators.

For both types of test an alternative rapid "one-point" procedure is given, which may give less accurate results.

The method of sample preparation is the same for all of these tests.

4.2 Sample preparation

4.2.1 General. Wherever possible the test shall be carried out on soil in its natural state. With many clay soils it is practicable and shall be permissible to remove by hand any coarse particles present, i.e. particles retained on a 425 μm test sieve. Otherwise these particles shall be removed by wet sieving as specified in 4.2.4.

In the definitive method the soil shall not be allowed to become dry before testing. Where air drying is required the method used shall be stated. Drying and breaking down procedures shall comply with 7.3.4, 7.3.5 and 7.4.3 of BS 1377-1:1990.

The requirements of Part 1 of this standard, where appropriate, shall apply to this test method.

4.2.2 Apparatus

4.2.2.1 Test sieves, of sizes 425 μm and 2 mm, with receiver.

4.2.2.2 Apparatus for determination of moisture content, as specified in 3.2.2.

4.2.2.3 A sharp knife.

4.2.2.4 An implement for shredding cohesive soil.

4.2.2.5 Two palette knives.

4.2.2.6 A corrosion-resistant airtight container, large enough to take 200 g to 300 g of wet soil.

4.2.2.7 A flat, glass plate, a convenient size being 10 mm thick and about 500 mm square.

4.2.2.8 A wash bottle containing distilled water complying with 5.1 of BS 1377-1:1990.

4.2.2.9 A corrosion-resistant container of 600 mL or 1 000 mL capacity.

4.2.2.10 A glass stirring rod.

4.2.3 Specimen from natural soil

4.2.3.1 From a soil in the natural state containing little or no material retained on a 425 µm test sieve, take a representative sample weighing about 500 g. Cut it into small pieces using a knife or shredder and remove any coarse particles by hand or with tweezers.

4.2.3.2 If coarse particles are present determine their mass and the mass of the sample used.

NOTE These weighings enable the approximate proportion of coarse material to be reported if required.

4.2.3.3 Transfer the soil to a flat glass plate. Add distilled water and mix thoroughly with two palette knives until the mass becomes a thick homogeneous paste.

4.2.3.4 Place the paste in an airtight container and allow to stand for about 24 h or for long enough to enable the water to permeate through the soil.

NOTE A maturing period of about 24 h is recommended for most soils but a shorter time may be acceptable for soils of low clay content. Very silty soils can be tested immediately after mixing.

4.2.4 Sieved specimen

4.2.4.1 Take a sample of the soil of sufficient size to give a test specimen weighing at least 300 g which passes the 425 µm test sieve.

4.2.4.2 From the sample take a representative specimen and determine its moisture content, w_n (in %), as specified in 3.2.

4.2.4.3 Weigh the remainder of the sample to an accuracy of within 0.01 g (m_6).

4.2.4.4 Place the weighed sample in a container under just enough distilled water to submerge it. A dispersant shall not be added. Stir the mixture until it forms a slurry.

4.2.4.5 Pour the slurry through a guard sieve or sieves nested in a 425 µm test sieve nested in a receiver. Use the minimum amount of additional distilled water to wash the fines through into the receiver, or into a large container if necessary, until the water passing the 425 µm test sieve is virtually clear.

4.2.4.6 Collect together the washed material retained on the sieves, dry it at 105 °C to 110 °C and weigh it to an accuracy of within 0.01 g (m_7).

4.2.4.7 Allow the fine soil particles in the wash water to settle and after a suitable interval pour off any clear water above the suspension.

4.2.4.8 Allow the suspension partially to dry in a current of warm air, protected from dust, until it forms a stiff paste. Alternatively, excess water may be removed by filtration under vacuum or pressure.

NOTE A suitable consistency corresponds to not more than 15 mm penetration of the cone penetrometer liquid limit apparatus, or not less than 50 blows of the Casagrande apparatus.

4.2.5 Calculations. For the sieved soil calculate the dry mass, m_d (in g), of the initial sample from the equation:

$$m_d = \left(\frac{100}{100 + w_n} \right) m_6$$

where

w_n is the moisture content (in %);

m_6 is the mass of the sample as determined in 4.2.4.3 (in g).

Calculate the percentage of particles passing the 425 µm test sieve, p_a , from the equation:

$$p_a = \left(\frac{m_d - m_7}{m_d} \right) 100 \%$$

where

m_7 is the mass of the sample as determined in 4.2.4.6 (in g).

4.3 Cone penetrometer method (definitive method)

4.3.1 General. This method covers the determination of the liquid limit of a sample of soil in its natural state, or of a sample of soil from which material retained on a 425 µm test sieve has been removed.

NOTE The method using the cone penetrometer is preferred to that employing the Casagrande apparatus (see 4.5), as the test is both easier to carry out and is capable of giving more reproducible results. The cone penetrometer apparatus is easier to maintain in correct adjustment and the test procedure is less dependent on the judgement of the operator. The results obtained with the cone penetrometer may differ slightly from those with the Casagrande apparatus, but in most cases up to a liquid limit of 100 these differences will not be significant and will be less than the normal variations likely to be obtained using the Casagrande apparatus.

The requirements of Part 1 of this standard, where appropriate shall apply to this test method.

4.3.2 Apparatus

4.3.2.1 A flat, glass plate, of which a convenient size is 10 mm thick and about 500 mm square.

4.3.2.2 Two palette knives or spatulas.

4.3.2.3 A penetrometer as used in bituminous material testing complying with BS 2000-49.

4.3.2.4 A cone of stainless steel or duralumin approximately 35 mm long, with a smooth, polished surface and an angle of $30 \pm 1^\circ$. To ensure that the point remains sufficiently sharp for the purposes of the test, the cone shall be replaced if, after continued use, the point can no longer be felt when brushed lightly with the tip of the finger when the tip of the cone is pushed through a hole 1.5 ± 0.02 mm in diameter, bored through a metal plate 1.75 ± 0.1 mm thick. The mass of the cone together with its sliding shaft shall be 80.00 ± 0.1 g (see Figure 1).

NOTE The effect of surface roughness is more significant than small variations in cone angle or bluntness of the tip.

4.3.2.5 One or more metal cups (55 ± 2) mm in diameter and (40 ± 2) mm deep with the rim parallel to the flat base.

4.3.2.6 An evaporating dish, of about 150 mm diameter.

4.3.2.7 Apparatus for moisture content determination of fine grained soils as specified in 3.2.2.

4.3.2.8 A wash bottle or beaker, containing distilled water complying with 5.1 of Part 1 of this standard.

4.3.2.9 A corrosion-resistant airtight container.

4.3.2.10 A metal straightedge about 100 mm long or a straight-bladed spatula.

4.3.2.11 A stopclock or stopwatch readable to 1 s.

4.3.3 Procedure

4.3.3.1 Take a sample of about 300 g from the soil paste prepared as specified in 4.2.3 (natural condition) or 4.2.4 (sieved soil) and place it on the glass plate.

4.3.3.2 Mix the paste for at least 10 min using the two palette knives. If necessary add more distilled water so that the first cone penetration reading is about 15 mm.

NOTE Some soils, e.g. clays of high plasticity and residual soils, may require up to 40 min of continuous mixing immediately before testing to obtain reliable results. If in doubt comparative tests should be carried out.

4.3.3.3 Push a portion of the mixed soil into the cup with a palette knife taking care not to trap air. Strike off excess soil with the straightedge to give a smooth level surface.

4.3.3.4 With the penetration cone locked in the raised position lower the supporting assembly so that the tip of the cone just touches the surface of the soil. When the cone is in the correct position a slight movement of the cup will just mark the soil surface. Lower the stem of the dial gauge to contact the cone shaft and record the reading of the dial gauge to the nearest 0.1 mm.

4.3.3.5 Release the cone for a period of 5 ± 1 s. If the apparatus is not fitted with an automatic release and locking device take care not to jerk the apparatus during this operation. After locking the cone in position lower the stem of the dial gauge to contact the cone shaft and record the reading of the dial gauge to the nearest 0.1 mm. Record the difference between the beginning and end of the drop as the cone penetration.

4.3.3.6 Lift out the cone and clean it carefully to avoid scratching.

4.3.3.7 Add a little more wet soil to the cup, taking care not to trap air, make the surface smooth as in 4.3.3.3 and repeat 4.3.3.4 to 4.3.3.6.

4.3.3.8 If the difference between the first and second penetration readings is not more than 0.5 mm record the average of the two penetrations and proceed to 4.3.3.9.

If the second penetration is more than 0.5 mm and less than 1 mm different from the first, carry out a third test. If the overall range is then not more than 1 mm record the average of the three penetrations and proceed to 4.3.3.9.

If the overall range is more than 1 mm remove the soil from the cup, remix and repeat 4.3.3.3 to 4.3.3.8 until consistent results are obtained and then proceed to 4.3.3.9.

4.3.3.9 Take a moisture content sample of about 10 g from the area penetrated by the cone and determine the moisture content as specified in 3.2.

4.3.3.10 Repeat 4.3.3.3 to 4.3.3.9 at least three more times using the same sample of soil to which further increments of distilled water have been added. Proceed from the drier to the wetter condition of the soil. The amount of water added shall be such that a range of penetration values of approximately 15 mm to 25 mm is covered by the four or more test runs and is evenly distributed. Each time soil is removed from the cup for the addition of water, wash and dry the cup.

4.3.3.11 If at any time during the above procedure the soil has to be left for a while on the glass plate cover the soil with the evaporating dish or a damp cloth to prevent the soil drying out.

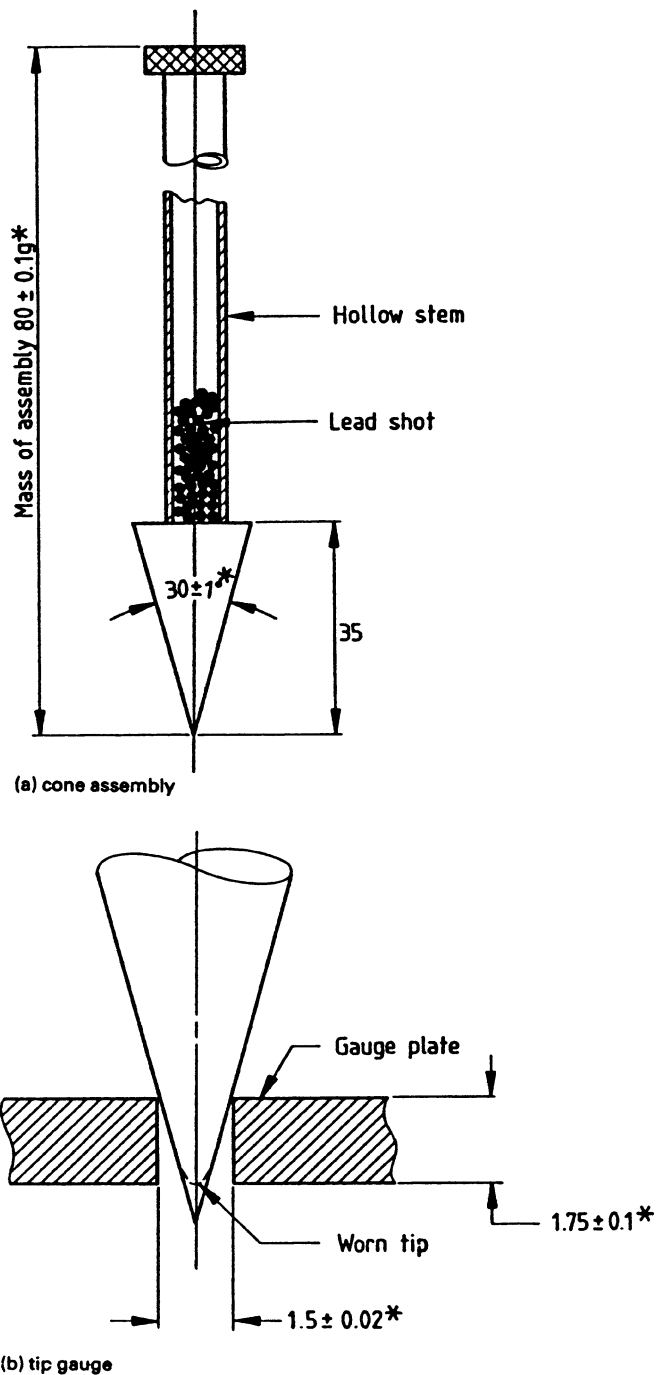

All dimensions are in millimetres.

Figure 1 — Details of cone for liquid limit test

4.3.4 *Calculations and expression of results*
(See form 2.C of appendix A).

4.3.4.1 Calculate the moisture content of each test specimen as specified in 3.2.

4.3.4.2 Plot the relationship between moisture content and cone penetration with the percentage moisture contents as abscissae and the cone penetrations as ordinates, both on linear scales.

4.3.4.3 Draw the best straight line fitting the plotted points.

4.3.4.4 From the linear graph read off the moisture content corresponding to a cone penetration of 20 mm to one decimal place.

4.3.4.5 Express the moisture content corresponding to a cone penetration of 20 mm to the nearest whole number and report it as the liquid limit (w_L) of the soil sample.

4.3.4.6 Express the percentage of material passing the 425 μm test sieve correct to the nearest whole number (see 4.2.5).

4.3.5 Test report. The test report shall affirm that the test was carried out in accordance with BS 1377-2:1990 and shall contain the following information:

- a) the method of test used;
- b) the liquid limit;
- c) the percentage of material retained on the 425 μm test sieve;
- d) the history of the material, e.g. whether tested in the natural state, or after wet sieving or after any other process;
- e) the information required by clause 9 of BS 1377-1:1990.

4.4 One-point cone penetrometer method

4.4.1 General. This method enables the liquid limit of a soil sample to be determined from only one measurement of moisture content. This method enables a result to be obtained when only a small amount of soil is available.

NOTE 1 The one-point method using the cone penetrometer is likely to give results that are less reliable than those obtained from the four-point method (see 4.3), and is therefore suitable only where a possibly less accurate result is acceptable.

NOTE 2 If it is suspected that the liquid limit is higher than about 120 % the method specified in 4.3 should be followed using the appropriate size of sample.

The requirements of Part 1 of this standard, where appropriate, shall apply to this test method.

4.4.2 Apparatus. The apparatus shall be the same as that specified in 4.3.2.

4.4.3 Procedure

4.4.3.1 Take a sample of about 100 g from the soil paste prepared as specified in 4.2.3 (natural condition) or 4.2.4 (sieved soil) and place it on the glass plate.

NOTE For many soils the influence of curtailing or omitting the curing time introduces errors that are unlikely to be greater than those inherent in this rapid procedure.

4.4.3.2 Thoroughly mix the paste with distilled water using the two palette knives. Adjust the moisture content to that corresponding to a cone penetration of between 15 mm and 25 mm, and as close as possible to 20 mm. This may be checked with the cone penetrometer device if necessary. Mix for at least 10 min.

NOTE Some soils e.g. clays of high plasticity and residual soils, may require up to 40 min of continuous mixing immediately before testing to obtain reliable results. If in doubt, comparative tests should be carried out.

4.4.3.3 Push a portion of the mixed soil into the cup with a palette knife, taking care not to trap air. Strike off excess soil with the straightedge to give a smooth surface.

4.4.3.4 With the cone locked in the raised position lower the supporting assembly so that the tip of the cone just touches the surface of the soil. When the cone is in the correct position a slight movement of the cup will just mark the soil surface. Record the reading of the dial gauge to the nearest 0.1 mm.

4.4.3.5 Release the cone for a period of 5 ± 1 s. If the apparatus is not fitted with an automatic release and locking device take care not to jerk the apparatus during this operation. After locking the cone in position lower the dial gauge to the new position of the cone shaft and note the reading to the nearest 0.1 mm. Record the difference between the beginning and end of the drop as the cone penetration.

4.4.3.6 Lift out the cone and clean it carefully to avoid scratching.

4.4.3.7 Add a little more wet soil to the cup, taking care not to trap air, make the surface smooth as specified in 4.4.3.3 and repeat 4.4.3.4 to 4.4.3.6.

4.4.3.8 Repeat 4.4.3.4 to 4.4.3.7 until two consecutive tests give cone penetration readings within 0.5 mm.

4.4.3.9 Remove the bulk of the soil, including the zone penetrated by the cone, from the cup. Place it in a suitable container and determine its moisture content as specified in 3.2.

4.4.4 Calculations and expression of results.

Calculate the moisture content of the test sample as specified in 3.2 and express the result to the first decimal place.

Obtain the factor corresponding to the cone penetration and the moisture content range from Table 1.

Calculate the liquid limit from the equation:

$$\text{liquid limit} = \text{moisture content} \times \text{factor}$$

and express the result to the nearest whole number.

4.4.5 Test report. The test report shall affirm that the test was carried out in accordance with BS 1377-2:1990 and shall contain the following information:

- a) the method of test used;
- b) the value of the liquid limit;
- c) the percentage of material retained on the 425 μm test sieve;

d) the history of the sample, e.g. whether tested in the natural state or after wet sieving or after any other process;

e) the information required by clause 9 of BS 1377-1:1990.

Table 1 — Factors for one-point cone penetrometer liquid limit test^a

Cone penetration mm	Factors for moisture content ranges		
	below 35 %	35 % to 50 %	above 50 %
15	1.057	1.094	1.098
16	1.052	1.076	1.075
17	1.042	1.058	1.055
18	1.030	1.039	1.036
19	1.015	1.020	1.018
20	1.000	1.000	1.000
21	0.984	0.984	0.984
22	0.971	0.968	0.967
23	0.961	0.954	0.949
24	0.955	0.943	0.929
25	0.954	0.934	0.909
Plasticity	low	intermediate	high

^a Reference: Clayton and Jukes, 1978

4.5 Casagrande apparatus method

4.5.1 General. This is an alternative method for the determination of the liquid limit of a sample of natural soil, or of a sample of soil from which material retained on a 425 µm test sieve has been removed.

NOTE The method using the Casagrande apparatus has been the accepted procedure for determining the liquid limit but experience has shown that it is difficult to maintain the apparatus in accordance with the standard and the results are subject to the judgement of the operator. For these reasons the method using the cone penetrometer is to be preferred, but provided that care is taken to ensure that the Casagrande apparatus is correctly maintained and the test procedure is strictly adhered to satisfactory results can be obtained. Results obtained using the Casagrande apparatus may differ slightly from those obtained from the cone method up to a liquid limit of 100 but in most cases these differences will not be significant and will be less than the normal variations likely to be obtained using the Casagrande apparatus. For liquid limits above 100 the cone method appears to give lower values.

The requirements of Part 1 of this standard, where appropriate, shall apply to this test method.

4.5.2 Apparatus

4.5.2.1 A flat, glass plate, of which a convenient size is 10 mm thick and about 500 mm square.

4.5.2.2 Two palette knives or spatulas.

4.5.2.3 A mechanical device complying with the essential details illustrated in Figure 2. The base shall be made of vulcanized rubber of hardness between 84° and 94° IRHD (International Rubber Hardness Scale D) and resilience between 20 % and 35 % at 20 ± 2 °C determined in accordance with BS 903. The formulation of the rubber shall be generally as specified in BS 1154 for type Z compounds but additional fillers, such as phenolic resin, can be used to produce the required hardness and resilience.

The hardness shall be determined at least once every 2 years by use of a hardness tester as specified in BS 903-A26 and the resilience by means of the Lupke pendulum apparatus as specified in BS 903-A8 whilst recognizing that the hardness is greater than 85° IRHD. Each test can be performed either on the full lamination thickness or on the full block thickness.

4.5.2.4 A grooving tool and gauge complying with the essential details illustrated in Figure 3.

NOTE The grooving tool should be withdrawn from use when the tip has worn to a width of 3 mm. It may be found useful to have a standard check gauge of the correct dimension against which the tool can be checked.

4.5.2.5 Apparatus for moisture content determination of fine grained soils as specified in 3.2.2.

4.5.2.6 A wash bottle or beaker, containing distilled water complying with 5.1 of BS 1377-1:1990.

4.5.2.7 A corrosion-resistant airtight container large enough to take 200 g to 250 g of wet soil.

4.5.3 Adjustment of apparatus. Inspect the liquid limit device, ensure that it is clean, dry and in good working order and that the cup falls freely and does not have excessive side play at its hinge. Inspect the grooving tool to ensure that it is clean, dry and that the critical dimensions are as shown in Figure 3 (see note to 4.5.2.4).

Adjust the height to which the cup of the liquid limit device is lifted so that when the cup is raised to its maximum height the 10 mm gauge will just pass between it and the base.

4.5.4 Procedure

4.5.4.1 Take a sample of about 300 g from the soil paste prepared as specified in 4.2.3 (natural condition) or 4.2.4 (sieved soil) and place it on the glass plate.

4.5.4.2 Mix the prepared paste for at least 10 min using the two palette knives. If necessary add more distilled water so that the first blow count (see 4.5.4.5) is about 50 blows.

NOTE Some soils, e.g. clays of high plasticity and residual soils, may require up to 40 min of continuous mixing immediately before testing to obtain reliable results. If in doubt comparative tests should be carried out.

Dimensions												
Letter	A		B		C		D		E		G	
mm	54 ± 0.5		2 ± 0.5		27 ± 0.5		12.5 ± 0.5		56 ± 0.5		10 ± 0.5	
Letter	H	J	K	L	M	N	P	Q	R	S	T	
mm	16 ± 0.5	60 ± 0.5	51 ± 2.0	150	130	27	28	6	22	19	45	

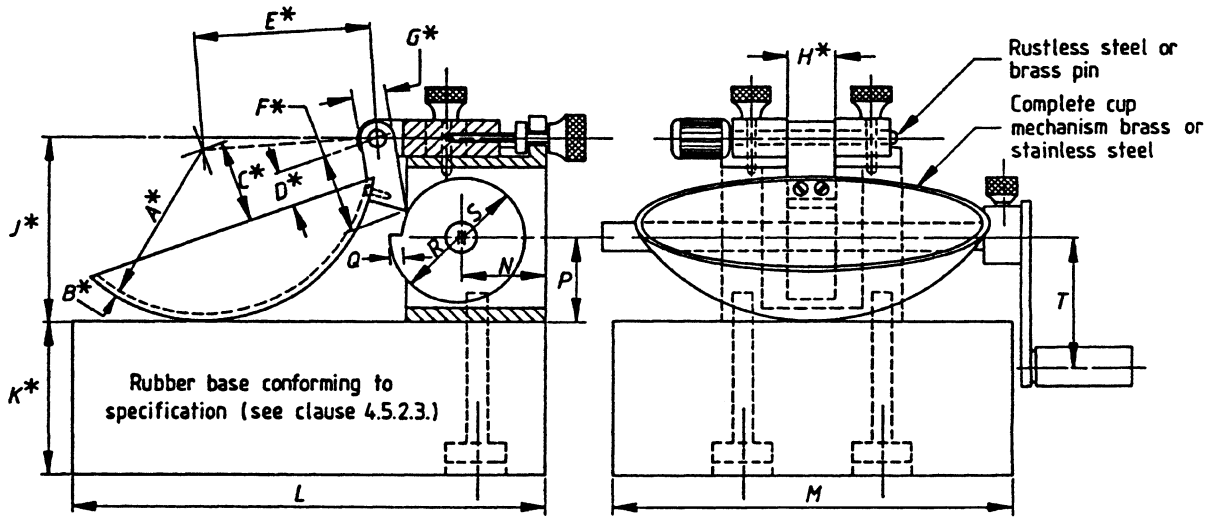

NOTE. This design has been found satisfactory, but alternative designs may be used provided that the essential requirements are fulfilled.

* See 4.1.3.1.1 of BS 1377 : Part 1 : 1990.

Figure 2 — Casagrande liquid limit apparatus

Dimensions							
Letter	A	B	C	D	E	F	
mm	2 ± 0.25	11 ± 0.25	40 ± 0.5	8 ± 0.25	50 ± 0.5	1.5 ± 0.1	
Letter	G	H	J	K	L	M	N
mm	13 ± 0.5	20	50	25	50	10 ± 0.25	20

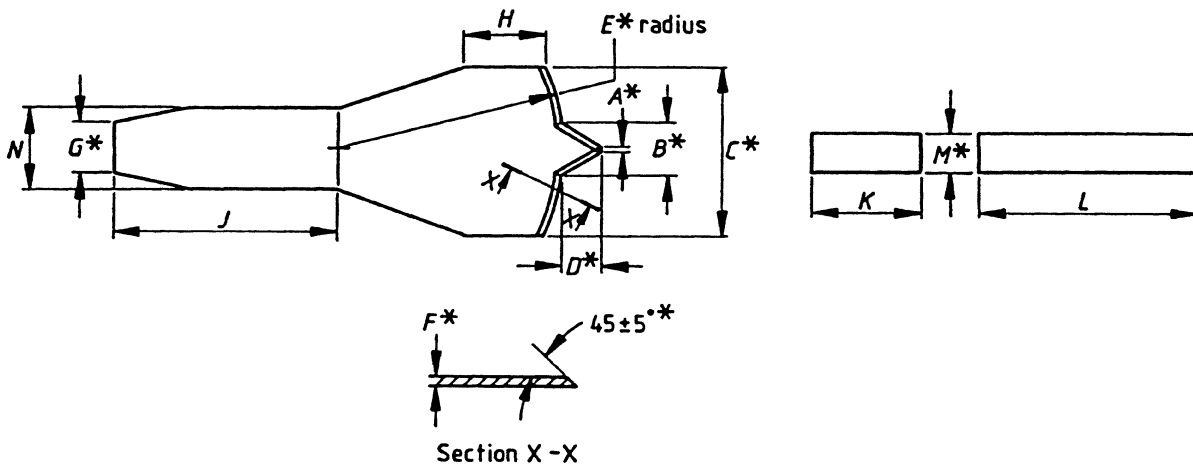

NOTE. This design has been found satisfactory, but alternative designs may be used provided that the essential requirements are fulfilled.

* See 4.1.3.1.1 of BS 1377 : Part 1 : 1990.

Figure 3 — Grooving tool and height gauge

4.5.4.3 With the cup of the apparatus resting on the base, place a portion of the mixed soil in the cup without entrapping air. Level off the soil surface parallel to the base.

4.5.4.4 Use the grooving tool to divide the soil into two equal parts by drawing the tool from the hinge towards the front in a continuous circular movement. Hold the grooving tool normal to the surface of the cup, with the chamfered edge facing the direction of movement.

NOTE With soils having low plasticity indices it is sometimes difficult to cut a smooth groove in the soil with the grooving tool. However, it does not necessarily follow that because a smooth groove cannot be obtained, the soil is non-plastic, and it should be recorded that the liquid limit could not be obtained by this method. The cone penetrometer method is the only practicable procedure for soils of this type.

4.5.4.5 Turn the crank handle at the rate of 2 r/s so that the cup is lifted and dropped, counting the number of bumps. Continue until the two parts of the soil come into contact at the bottom of the groove along a distance of 13 mm, measured with the end of the grooving tool or with a ruler. Record the number of bumps at which this occurs.

NOTE Sometimes the soil flows so as to leave a gap between two areas of contact. The test should continue until there is a length of continuous contact for 13 mm.

4.5.4.6 Add a little more of the prepared soil from the glass plate and mix it with the soil in the cup.

4.5.4.7 Repeat **4.5.4.3** to **4.5.4.5** until two consecutive runs give the same number of bumps for closure.

NOTE 1 Some soils tend to slide on the surface of the cup instead of flow taking place within the soil. If this occurs the result should be discarded and the test repeated until flowing does occur. If, after additional increments of water, sliding still occurs, the test is not applicable and a note should be made that the liquid limit could not be obtained by this method. The cone penetrometer method (see **4.3**) should be used instead.

NOTE 2 Care should be taken to see that the sample does not dry out between repeat tests as the number of blows for closure will increase gradually as the sample dries.

4.5.4.8 Take about 10 g of soil with a spatula from the portions of the sample that have just flowed together. Place the soil in a suitable container and determine the moisture content as specified in **3.2**.

4.5.4.9 Repeat **4.5.4.3** to **4.5.4.8** at least three more times using the same sample of soil to which further increments of distilled water have been added.

Proceed from the drier to the wetter condition of the soil. The amount of water added shall be such that when the four or more moisture contents are plotted they are evenly distributed over the range between 50 bumps to 10 bumps. Each time the soil is removed from the cup for the addition of water, wash and dry the cup and grooving tool.

4.5.4.10 If at any time during the above procedure the soil has to be left for a while on the glass plate, cover the soil with the evaporating dish or a damp cloth to prevent the soil drying out.

4.5.5 *Calculations and expression of results* (See form 2.D of appendix A.)

Calculate the moisture content of each test sample and express the result as specified in **3.2**.

Plot the relationship between the moisture content and the corresponding number of bumps on a semi-logarithmic chart, with the percentage moisture contents as ordinates on the linear scale and the number of bumps as abscissae on the logarithmic scale.

Draw the best straight line fitting the plotted points (the "flow curve").

From the flow curve read off the moisture content corresponding to the abscissa of 25 blows to the first decimal place.

Express this moisture content to the nearest whole number and report it as the liquid limit.

4.5.6 *Test report.* The test report shall affirm that the test was carried out in accordance with this Part of this standard and shall contain the following information:

- a) the method of test used;
- b) the value of the liquid limit;
- c) the percentage of material passing the 425 μm test sieve;
- d) the history of the sample, e.g. whether tested in the natural state or after wet sieving or after any other process.
- e) the information required by clause **9** of BS 1377-1:1990.

4.6 One-point Casagrande method

4.6.1 *General.* This method enables the liquid limit of a soil sample to be determined from only one measurement of moisture content. This method enables a result to be obtained when only a small amount of soil is available.

NOTE 1 The one-point method using the Casagrande apparatus is likely to give results that are less reliable than those obtained from the four-point method of **4.5** and is therefore suitable only where a possibly less accurate result is acceptable.

NOTE 2 If it is suspected that the liquid limit is higher than about 120 % the procedure given in **4.3** or **4.5** should be followed using the appropriate size of sample.

The requirements of Part 1 of this standard, where appropriate, shall apply to this test method.

4.6.2 *Apparatus.* The apparatus shall be the same as that specified in **4.5.2**.

4.6.3 *Adjustment of apparatus.* The apparatus shall be adjusted as specified in **4.5.3**.

4.6.4 Procedure

4.6.4.1 Take a sample of about 100 g from the soil paste prepared as specified in **4.2.3** (natural condition) or **4.2.4** (sieved soil) and place it on the glass plate.

NOTE For many soils the influence of curtailing or omitting the curing time introduces errors that are unlikely to be greater than those inherent in this procedure.

4.6.4.2 Thoroughly mix the paste with distilled water using the two palette knives. Adjust the moisture content to that corresponding to the value for between 15 bumps and 35 bumps of the Casagrande machine and as close as possible to 25 bumps. This may be checked with the machine if necessary. Mix for at least 10 min.

NOTE 1 As can be seen from Table 2 the nearer the moisture content is to that at 25 bumps the less is the error due to the variation of the slope of the flow line from the slope of the calculated line obtained from the equation:

$$w_L = w \left(\frac{n}{25} \right)^{\tan B}$$

where

w_L is the liquid limit (in %);

w is the moisture content corresponding to n blows (in %);

$\tan B = 0.092$ (the slope of the calculated flow line relating $\log(w_L)$ to $\log(w)$ for British soils).

NOTE 2 The amount of distilled water added should be such that the number of bumps is less rather than more than 25 because during mixing and placing some moisture tends to evaporate causing the soil to be drier when actually tested.

NOTE 3 Some soils, e.g. clays of high plasticity and residual soils, may require up to 40 min of continuous mixing immediately before testing to obtain reliable results. If in doubt comparative tests should be carried out.

4.6.4.3 With the cup of the apparatus resting on the base, place a portion of the mixed soil in the cup without entrapping air. Level off the soil surface parallel to the base.

4.6.4.4 Use the grooving tool to divide the soil into two equal parts by drawing the tool from the hinge towards the front in a continuous circular movement. Hold the grooving tool normal to the surface of the cup, with the chamfered edge facing the direction of movement.

NOTE With soils having low plasticity indices it is sometimes difficult to cut a smooth groove in the soil with the grooving tool specified. However, it does not necessarily follow that because a smooth groove cannot be obtained the soil is non-plastic, and it should be recorded that the liquid limit could not be obtained by this method. The cone penetrometer method is the only practicable procedure for soils of this type.

4.6.4.5 Turn the crank handle at the rate of 2 r/s so that the cup is lifted and dropped, counting the number of bumps. Continue until the two parts of the soil come into contact at the bottom of the groove along a distance of 13 mm, measured with the end of the grooving tool or with a ruler. Record the number of bumps at which this occurs. The number shall be between 15 bumps and 35 bumps.

NOTE Sometimes the soil flows so as to leave a gap between two areas of contact. The test should continue until there is a length of continuous contact for 13 mm.

4.6.4.6 Add a little more of the prepared soil from the glass plate and mix it with the soil in the cup.

4.6.4.7 Repeat **4.6.4.3** to **4.6.4.5** until two consecutive runs give the same number of bumps for closure.

NOTE 1 Some soils tend to slide on the surface of the cup instead of flow taking place within the soil. If this occurs the result should be discarded and the test repeated until flowing does occur. If, after additional increments of water, sliding still occurs, the test is not applicable and a note should be made that the liquid limit could not be obtained by this method.

NOTE 2 Care should be taken to see that the sample does not dry out between repeat tests as the number of bumps for closure will increase gradually as the sample dries.

4.6.4.8 Remove the bulk of the soil from the cup and place it in a suitable container and determine its moisture content as specified in **3.2**.

4.6.5 Calculations and expression of results.

Calculate the moisture content of the test sample as specified in **3.2** to the first decimal place.

Obtain the factor corresponding to the number of bumps obtained in the test from Table 2.

Calculate the liquid limit from the equation:

$$\text{Liquid limit} = \text{moisture content} \times \text{factor}$$

and express the result to the nearest whole percentage number.

4.6.6 Test report. The test report shall affirm that the test was carried out in accordance with BS 1377-2:1990 and shall include the following:

- a) the method of test used;
- b) the value of the liquid limit;
- c) the percentage of material passing the 425 μm test sieve;
- d) the history of the sample, e.g. whether tested in the natural state, after wet sieving or after any other process;
- e) the information required by clause **9** of BS 1377-1:1990.

Table 2 — Factors for one-point Casagrande liquid limit test

Number of bumps	Factor	Number of bumps	Factor	Number of bumps	Factor	Number of bumps	Factor
15	0.95	21	0.98	26	1.00	31	1.02
16	0.96	22	0.99	27	1.01	32	1.02
17	0.96	23	0.99	28	1.01	33	1.02
18	0.97	24	0.99	29	1.01	34	1.02
19	0.97	25	1.00	30	1.02	35	1.03
20	0.98						

5 Determination of the plastic limit and plasticity index

5.1 General

The plastic limit is the empirically established moisture content at which a soil becomes too dry to be plastic. It is used together with the liquid limit to determine the plasticity index which when plotted against the liquid limit on the plasticity chart (see BS 5930) provides a means of classifying cohesive soils. It is recognized that the results are subject to the judgement of the operator, and that some variability in results will occur.

5.2 Sample preparation

Samples for test shall be prepared as specified in 4.2. The soil shall not be allowed to become dry before testing. Where air drying is required the method used shall be stated. Drying and breaking down procedures shall comply with 7.3.4, 7.3.5 and 7.4.3 of BS 1377-1:1990.

It is convenient to carry out the test on a portion of the material prepared for one of the liquid limit test procedures specified in clause 4.

5.3 Method for plastic limit

5.3.1 General. This method covers the determination of the plastic limit of a soil sample, i.e. the lowest moisture content at which the soil is plastic. The sample shall be of soil in its natural state, or of soil from which material retained on a 425 µm test sieve has been removed.

The requirements of Part 1 of this standard, where appropriate, shall apply to this test method.

5.3.2 Apparatus

5.3.2.1 A flat, glass plate, as specified in 4.3.2.1, on which the soil is mixed.

5.3.2.2 A flat, glass plate, smooth and free from scratches, on which threads are rolled. A convenient size of plate is about 10 mm thick and 300 mm square.

NOTE The condition of the surface of the glass plate affects the behaviour of the rolled threads. Mixing of soil containing silica particles inevitably scratches a glass surface. Use of a separate unscratched glass plate for the rolling operation will reduce discrepancies due to this effect.

5.3.2.3 Two palette knives or spatulas.

5.3.2.4 Apparatus for the moisture content determination of fine-grained soils as specified in 3.2.2.

5.3.2.5 A length of rod, 3 mm in diameter and about 100 mm long.

5.3.3 Procedure

5.3.3.1 Take a sample of about 20 g from the soil paste prepared as specified in 4.2.3 (natural condition) or 4.2.4 (sieved soil) and place it on the glass mixing plate.

5.3.3.2 Allow the soil to dry partially on the plate until it becomes plastic enough to be shaped into a ball.

5.3.3.3 Mould the ball of soil between the fingers and roll it between the palms of the hands until the heat of the hands has dried the soil sufficiently for slight cracks to appear on its surface. Divide this sample into two subsamples of about 10 g each and carry out a separate determination on each portion. Divide each subsample into four more or less equal parts and treat each part as specified in 5.3.3.4 to 5.3.3.8.

5.3.3.4 Mould the soil in the fingers to equalize the distribution of moisture, then form the soil into a thread about 6 mm diameter between the first finger and thumb of each hand.

5.3.3.5 Roll the thread between the fingers, from finger-tip to the second joint, of one hand and the surface of the glass rolling plate. Use enough pressure to reduce the diameter of the thread to about 3 mm in five to 10 complete, forward and back, movements of the hand. Some heavy clays will require 10 to 15 movements when the soil is near the plastic limit because the soil hardens at this stage. It is important to maintain a uniform rolling pressure; do not reduce the pressure as the thread diameter approaches 3 mm.

5.3.3.6 Pick up the soil, mould it between the fingers to dry it further, form it into a thread and roll it out again as specified in **5.3.3.5**.

NOTE Gradually drying of the soil is effected by alternately rolling and moulding, not by continual rolling, either as a ball or as threads, which produces a dried crust.

5.3.3.7 Repeat **5.3.3.6** until the thread shears both longitudinally and transversely when it has been rolled to about 3 mm diameter, as gauged by the rod. Do not gather the pieces of soil together after they have crumbled, in order to reform a thread and to continue rolling; the first crumbling point is the plastic limit.

NOTE With soils that are marginally plastic it is often difficult to obtain the correct crumbling condition.

5.3.3.8 Gather together the portions of the crumbled soil thread, transfer them to a suitable container and replace the lid immediately.

5.3.3.9 Repeat **5.3.3.4** to **5.3.3.8** on the other three portions of soil, placing them all in the same container. Determine the moisture content of the soil in the container as specified in **3.2**.

5.3.3.10 Repeat **5.3.3.3** to **5.3.3.9** on the duplicate sample formed in **5.3.3.3**.

5.3.4 Calculations and expression of results (Form 2.C or form 2.D of appendix A may be used.)

Calculate the moisture content of both samples by testing in accordance with the method described in **3.2** but utilizing the samples obtained from **5.3.3**. If the two results differ by more than 0.5 % moisture content, repeat the whole test.

Calculate the average of the two moisture content values and express the value to the nearest whole number. This is the plastic limit.

5.3.5 Test report. The test report shall affirm that the test was carried out in accordance with BS 1377-2:1990 and shall include the following information:

- a) the method of test used;
- b) the plastic limit of the soil sample;
- c) the percentage of material passing the 425 μm test sieve;
- d) the history of the sample, e.g. whether tested in the natural state, or after wet sieving or after any other process;
- e) The information required by clause **9** of BS 1377-1:1990.

If it is not possible to determine the plastic limit this fact shall be reported.

5.4 Derivation of plasticity Index and liquidity Index

5.4.1 General. This method covers the determination of the plasticity index and the liquidity index of a soil.

5.4.2 Procedure. Determine the moisture content, w_a , of the fraction passing a 425 μm test sieve of the sample of soil in its natural condition by one of the procedures specified in clause **3**. (See note to **3.2.4**.)

Determine the liquid limit, w_L , by one of the procedures specified in clause **4**, and the plastic limit, w_p , by the procedure specified in **5.3**.

5.4.3 Calculations. Calculate the plasticity index, I_p , from the equation:

$$I_p = w_L - w_p$$

Calculate the liquidity index, I_L , from the equation:

$$I_L = \frac{w_a - w_p}{I_p}$$

6 Determination of shrinkage characteristics

6.1 General

6.1.1 Objective. Shrinkage due to drying is significant in clays but less so in silts and sands. These tests enable the shrinkage limit, w_s , of clays to be determined, i.e. the moisture content below which a clay ceases to shrink. They also provide ways of quantifying the amount of shrinkage likely to be experienced by clays, in terms of the shrinkage ratio, volumetric shrinkage and linear shrinkage.

These factors are also relevant to the converse condition of expansion due to wetting.

6.1.2 Types of test. Three types of test are specified. The first is the definitive method in which volumetric measurements are made on a cylindrical specimen, usually of undisturbed soil, as it is allowed to dry. The second is the subsidiary method, in which disturbed soil is mixed to a paste with water to form a small pat for the same purpose. Both procedures enable the shrinkage limit of the soil, the shrinkage ratio, and the volumetric shrinkage for a given change of moisture content, to be determined. In the third test only the total linear shrinkage of a soil paste is measured.

The second and third procedures are carried out on the fraction of the soil sample passing a 425 μm test sieve.

6.2 Sample preparation

The cylindrical specimen for the test specified in **6.3** shall be prepared by one of the procedures specified in clause **7** of BS 1377-1:1990 depending on whether the specimen is to be of undisturbed, remoulded or compacted soil, and the type or size of the original sample.

Samples for the tests specified in 6.4 and 6.5 shall be prepared in the same way as specified in 4.2. Wherever possible, soil in the natural state shall be used and particles larger than 425 μm shall be removed by hand.

In the definitive method the soil shall not be allowed to become dry before testing. Where air drying is required the method used shall be stated. Drying and breaking down procedures shall comply with 7.3.4, 7.3.5 and 7.4.3 of BS 1377-1:1990.

6.3 Volumetric shrinkage (definitive method)

6.3.1 General. This test covers the determination of the shrinkage limit of a cylindrical specimen of undisturbed or remoulded soil by measuring its volume as its moisture content decreases from the initial value and plotting the shrinkage curve. The soil specimen is ideally of 38 mm to 51 mm diameter, with a length of between 1 diameter and 2 diameters.

The requirements of Part 1 of this standard, where appropriate, shall apply to this test method.

6.3.2 Apparatus

6.3.2.1 Shrinkage limit apparatus, of the type shown in Figure 4. The essential features are as follows:

- immersion tank for containing mercury;
- wire cage for enclosing the specimen;
- micrometer measuring device, readable to 0.01 mm, complying with 4.2.1.3 of BS 1377-1:1990.
- electrical circuit with battery, indicator lamp and platinum contact mounted on the tip of the micrometer stem, such that contact with the mercury surface completes the circuit and lights the lamp;
- circuit test switch;
- levelling screws on the base, and circular levelling bubble;
- dished top surface, to allow spilt droplets of mercury to run back into the tank.

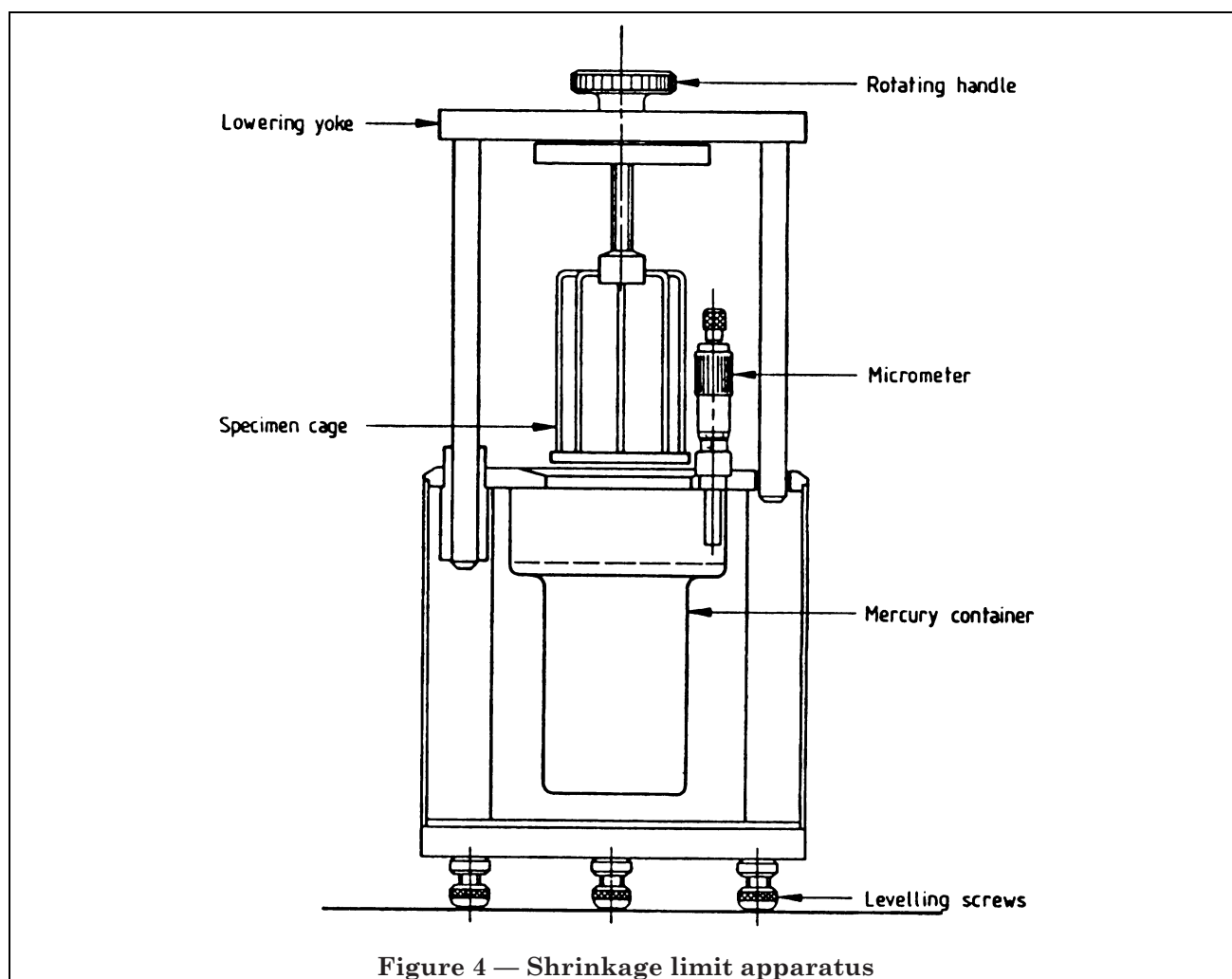

Figure 4 — Shrinkage limit apparatus

6.3.2.2 Mercury metal, sufficient to fill the tank of the apparatus to the required level.

WARNING: Mercury is a hazardous substance and the appropriate precautionary measures should be taken when using it. Reference should be made to current Government regulations and to Guidance Note MS 12, Health & Safety Executive: Mercury — medical surveillance (HMSO, June 1979). Operations involving the use of mercury should be carried out in a fume cupboard or in the vicinity of an air-extractor fan so that any mercury vapour can be removed immediately.

Adequate provision should be made for the removal of vapour from the drying oven.

6.3.2.3 Tray containing a little water, on which to stand the apparatus so that any spilled mercury can be retained.

6.3.2.4 Balance readable to 0.01 g.

6.3.2.5 Watch glass.

6.3.2.6 Tongs for lifting the specimen.

6.3.2.7 Small brush, for brushing droplets of mercury.

6.3.2.8 Apparatus for determination of moisture content as specified in 3.2.

6.3.2.9 Mould or tube for forming the test specimen, and suitable cutting and trimming tools, as specified in 8.2.1 and 8.2.3 of BS 1377-1:1990.

6.3.2.10 Rubber gloves.

6.3.3 Preparation of apparatus

6.3.3.1 Determine the internal diameter, D , of the mercury tank to 0.1 mm.

6.3.3.2 Place the apparatus on a firm bench, situated in a fume cupboard or in the vicinity of an air-extractor fan.

6.3.3.3 Level the apparatus by means of the base adjusting screws.

6.3.3.4 Add mercury carefully to the tank, to the required depth.

6.3.3.5 Readjust the apparatus if necessary to ensure that it remains level.

6.3.3.6 Use the test switch to check the electrical circuit.

6.3.3.7 Lower the cage into the mercury tank until it is completely submerged, and rotate it a few times to dislodge any air bubbles.

6.3.3.8 Adjust the micrometer until the platinum contact just touches the surface of the mercury, as indicated by the indicator lamp.

6.3.3.9 Record the reading of the micrometer as the zero reading, M_0 (in mm).

6.3.3.10 Raise the cage out of the tank and raise the micrometer adjustment.

6.3.4 Preparation of the specimen. Prepare the cylindrical specimen by one of the methods specified in clause 8 of BS 1377-1:1990.

Measure the initial length and diameter of the specimen to the nearest 0.01 mm, as specified in 7.2.4. Record the average values of length, L_1 , and diameter, D_1 .

NOTE These measurements provide a check on the volume measurements obtained from the shrinkage limit apparatus, but are not essential.

Weigh the specimen to 0.01 g, and record it as the initial mass, m_1 .

6.3.5 Test procedure

6.3.5.1 Place the soil specimen in the cage of the shrinkage limit apparatus and lower the cage until it is completely immersed in the mercury. Rotate the cage a few times to dislodge any air bubbles.

6.3.5.2 Adjust the micrometer so that contact with the mercury is just made, lighting the lamp.

6.3.5.3 Record the micrometer reading, M (in mm), and calculate the difference between M and the zero reading, M_0 .

6.3.5.4 Raise the cage, remove the specimen and carefully brush off any droplet of mercury back into the tank.

6.3.5.5 Weigh the specimen immediately to 0.01 g (m).

6.3.5.6 Place the specimen on a watch glass and leave it standing exposed to the air at room temperature for about 2 h so as to dry partially.

6.3.5.7 Repeat 6.3.5.1 to 6.3.5.6, determining the zero reading each time as described in 6.3.3.7 to 6.3.3.10, and obtain sets of micrometer readings and the corresponding mass. Continue until three successive differences in micrometer readings show no change with reducing mass.

NOTE 1 At this point the soil will normally take on a lighter colour.

NOTE 2 The drying process may take several days. It should not be hurried, e.g. by oven drying, otherwise cracks may develop in the specimen. Mercury may not fully penetrate very fine cracks, which would give a false reading of volume. Wider cracks may fill with mercury which could remain entrapped, giving a false mass.

NOTE 3 If necessary cover the specimen with a damp cloth under a polyethelene sheet to prevent too much loss of moisture overnight.

6.3.5.8 When no further shrinkage is taking place, dry the specimen to constant mass at 105 °C to 110 °C.

NOTE The oven and its surroundings should be adequately ventilated to eliminate any mercury vapour.

6.3.5.9 Cool the dried specimen in a desiccator and weigh it to 0.01 g (m_d).

6.3.5.10 Immerse the dry specimen in the mercury tank and determine the micrometer reading, M_d , as specified in 6.3.5.1 to 6.3.5.4.

6.3.6 Calculation, plotting and expression of results

(See form 2.E of appendix A.)

Calculate the initial volume, V_1 (in cm^3), and density, ρ (in Mg/m^3), of the specimen from the equations:

$$V_1 = \frac{\pi D_1^2 L_1}{4000}$$

$$\rho = \frac{m_1}{V_1}$$

where

D_1 is the average diameter of the specimen (in mm);

L_1 is the average length of the specimen (in mm);

m_1 is the initial mass of the specimen (in g).

Calculate the volume of the specimen, V (in cm^3), corresponding to each pair of micrometer readings, M_0 and M (in mm), from the equation:

$$V = (M - M_0) \left(\frac{\pi D^2}{4000} \right)$$

where

D is the internal diameter of the mercury tank (in mm);

M is the micrometer reading (in mm);

M_0 is the zero reading of the micrometer (in mm).

After oven drying, the value of V , calculated from the above equation but using $M = M_d$, is denoted by V_d , i.e. the measured volume of the specimen after oven drying.

Calculate the unit volume, U (in cm^3 per 100 g of dry soil), for each measurement from the equation:

$$U = \left(\frac{V}{m_d} \right) 100$$

where

m_d is the oven-dried mass of the dried specimen (in g).

Calculate the moisture content of the specimen, w (in %), corresponding to each measurement from the equation:

$$w = \left(\frac{m - m_d}{m_d} \right) 100$$

where

m is the mass of the specimen for that measurement.

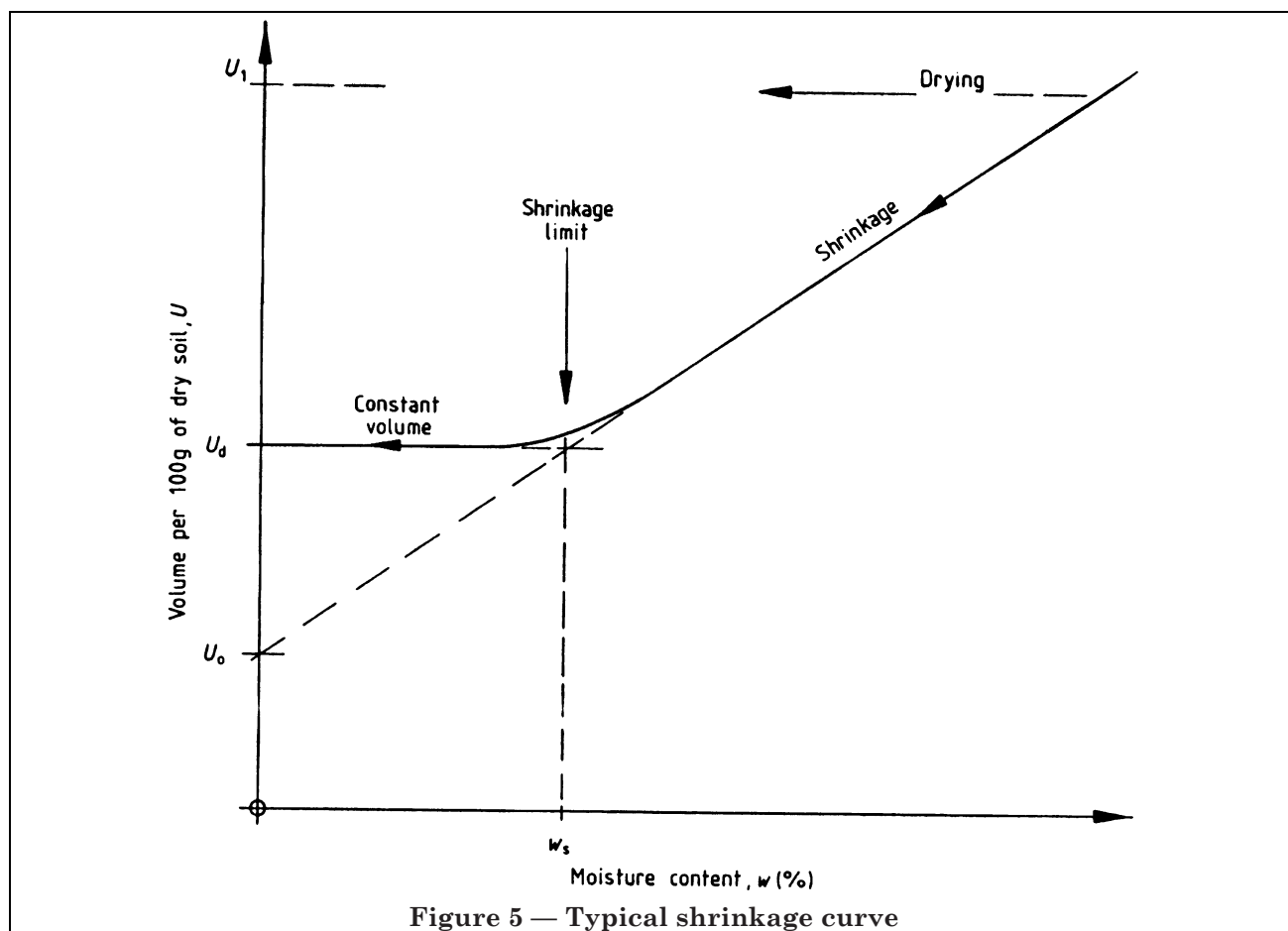

Figure 5 — Typical shrinkage curve

Plot the values of U as ordinates against w as abscissae. Plot the unit volume in the dry state, U_d (in cm^3 per 100 g of dry soil), at zero moisture content, from the equation:

$$U_d = \left(\frac{V_d}{m_d} \right) 100$$

where

V_d is the measured volume of the specimen after oven drying (in cm^3).

Draw a horizontal straight line through the point representing U_d , and draw the inclined straight line of best fit through the points representing the first few readings. A typical graphical plot is shown in Figure 5.

NOTE The inclined line produced downwards theoretically intersects the vertical U axis at a value U_0 given by the equation:

$$U_0 = \left(\frac{m_d}{\rho_s} \right) 100$$

where

ρ_s is the particle density of the soil (in Mg/m^3).

Determine the moisture content, w_s (in %), at the point where the two lines intersect. This value is the shrinkage limit.

Calculate the shrinkage ratio, R_s , from the equation:

$$R_s = \frac{m_d}{V_d}$$

The volumetric shrinkage of the soil, V_s (in cm^3), corresponding to a decrease in moisture content from a given value, w (in %), to the shrinkage limit is calculated from the equation:

$$V_s = \frac{w - w_s}{R_s}$$

where

V_s is the decrease in volume (in cm^3) expressed as a percentage of the soil mass (in g) when dried;

w is the given moisture content of the soil (in %).

Express the moisture content corresponding to the shrinkage limit, w_s , to the nearest whole number.

Express the shrinkage ratio to two significant figures.

6.3.7 Test report. The test report shall affirm that the test was carried out in accordance with BS 1377-2:1990 and shall include the following information:

- the method of test used;
- the shrinkage limit;

- the initial moisture content of the specimen;
- the initial density of the specimen;
- the plot of the shrinkage curve;
- the shrinkage ratio;
- the percentage of material passing the 425 μm test sieve;
- the history of the test specimen, e.g. whether prepared from undisturbed natural soil, from remoulded soil or from compacted soil;
- the method of preparation;
- the information required by clause 9 of BS 1377-1:1990.

6.4 Volumetric shrinkage (subsidiary method)

6.4.1 General. This test covers the determination of the shrinkage limit and the shrinkage ratio of the fraction of a soil sample passing a 425 μm test sieve by volumetric measurements on a small pat of the soil. The volumetric shrinkage from a given moisture content can also be calculated. The method includes the optional derivation of the shrinkage curve during drying.

The requirements of Part 1 of this standard, as appropriate, shall apply to this test method.

6.4.2 Apparatus

6.4.2.1 Shrinkage dish, a circular dish of porcelain or monel metal with a flat bottom, about 44 mm internal diameter and about 12 mm deep.

6.4.2.2 Glass cup, about 57 mm in diameter and 32 mm deep, having the top rim ground smooth and flat and essentially parallel to the base.

6.4.2.3 Flat sheet of glass or clear acrylic, large enough to cover the glass cup, fitted with three non-corrodible prongs as shown in Figure 6 a); referred to as the prong plate.

6.4.2.4 Glass plate, large enough to cover the shrinkage dish.

6.4.2.5 Two porcelain evaporating dishes, each about 150 mm in diameter.

6.4.2.6 Glass measuring cylinder, 25 mL capacity reading to 0.1 mL.

6.4.2.7 Mercury, rather more than will fill the glass cup.

WARNING: Mercury is a hazardous substance and the appropriate precautionary measures should be taken. Reference should be made to current Government regulations and to Guidance Note MS 12, Health and Safety Executive: Mercury — medical surveillance (HMSO, June 1979). Operations involving the use of mercury should be carried out in a fume cupboard or in the vicinity of an air-extractor fan so that any mercury vapour can be removed immediately. Adequate provision should be made for the removal of vapour from the drying oven.

6.4.2.8 *Steel straightedge* about 100 mm long.

6.4.2.9 *Two palette knives* or spatulas.

6.4.2.10 *Apparatus for determination of moisture content* as specified in 3.2.

6.4.2.11 *Large tray* containing a small amount of water, to retain any spilled mercury.

6.4.2.12 *Petroleum jelly*.

6.4.2.13 *Small brush*, for brushing droplets of mercury.

6.4.2.14 *Distilled water*, complying with 5.1 of BS 1377-1:1990.

6.4.3 Preparation of apparatus

6.4.3.1 Clean and dry the shrinkage dish, and weigh it to 0.01 g (m_2).

6.4.3.2 Determine the internal volume of the shrinkage dish by placing the shrinkage dish in an evaporating dish and filling it to overflowing with mercury. Then press the small plain glass plate firmly over the top of the shrinkage dish so that excess mercury is displaced without entrapping any air. Carefully remove the glass plate and transfer all the mercury in the shrinkage dish to the measuring cylinder. Record the volume of mercury to 0.1 mL (V_1) as the initial volume of soil tested.

6.4.3.3 Coat the inside of the shrinkage dish with a thin layer of petroleum jelly to prevent sticking of the soil.

6.4.4 Procedure

6.4.4.1 Place a sample of about 50 g from the material passing the 425 μm test sieve, obtained as specified in 4.2.4, into an evaporating dish. Alternatively take a sample of natural soil from which coarse particles have been removed and thoroughly mix it with distilled water in the evaporating dish to make a readily workable paste.

6.4.4.2 Add distilled water if necessary and mix thoroughly using the palette knives until the mass becomes a smooth homogeneous paste with a moisture content a little above the liquid limit.

NOTE The exact moisture content is not critical to within a few percent. The required consistency will give a cone penetration of about 25 mm to 28 mm in the cone penetrometer liquid limit device, or will require about 10 bumps of the Casagrande apparatus.

6.4.4.3 Place enough of the soil paste in the centre of the shrinkage dish to fill it about one-third full, without entrapping pockets of air. Tap the dish on a firm surface, padded with a few layers of blotting paper or similar material, to cause the soil to flow to the edges of the dish and to release any air bubbles present.

Add a second amount of soil paste about equal to the first, and repeat the tapping operation until all entrapped air has been released.

6.4.4.4 Add more soil paste, and continue the tapping operation until the shrinkage dish is completely filled and free of air, with an excess standing out above the edge. Strike off the excess with the straightedge and clean off any soil adhering to the outside of the dish.

6.4.4.5 Weigh the soil and dish immediately to 0.01 g (m_3).

If only the numerical results are required, proceed to 6.4.4.9. If the shrinkage curve during drying is required, follow the procedures specified in 6.4.4.6 to 6.4.4.8.

NOTE Steps 6.4.4.6 to 6.4.4.8 may not be practicable for soils of low clay content.

6.4.4.6 Leave the soil in the shrinkage dish exposed to air for a few hours to allow it to dry partially. When the soil pat has shrunk away from the side of the dish and can be safely handled, carefully remove it from the dish and determine its volume, V , as specified in 6.4.4.11. Weigh the soil pat to 0.01 g (m).

NOTE If the soil pat cracks or breaks the test should be repeated, allowing the pat to dry more slowly.

6.4.4.7 Place the soil pat on a flat surface and allow it to dry further in air. Then determine its mass, and its volume as specified in 6.4.4.11.

6.4.4.8 Repeat 6.4.4.7 until the measured volume is practically constant, then proceed as specified in 6.4.4.10.

6.4.4.9 Leave the soil in the shrinkage dish exposed to air to allow it to dry until the colour of the soil changes from dark to light.

6.4.4.10 Dry the soil in the dish to constant mass in an oven maintained at 105 °C to 110 °C. Cool and weigh to 0.01 g as specified in 3.2.3.1.3 and 3.2.3.1.4 (m_4).

6.4.4.11 Remove the soil pat from the dish and determine its volume as follows (see note to 6.4.4.6).

6.4.4.11.1 Place the glass cup in a clean evaporating dish standing on a large tray. Fill the cup to overflowing with mercury, and remove excess mercury by pressing the prong plate firmly on the top of the cup. Avoid trapping air under the plate.

6.4.4.11.2 Carefully remove the prong plate and brush off any mercury drops adhering to the outside of the cup. Place the cup into a second clean evaporating dish without spilling any mercury.

6.4.4.11.3 Place the soil pat on the surface of the mercury and carefully force it under the mercury with the three prongs of the prong plate (see Figure 6(b)). Ensure that no air is trapped under the soil pat. Press the prong plate firmly on to the cup without entrapping air and brush off any droplets of mercury adhering to it into the evaporating dish.

6.4.4.11.4 Transfer all the mercury displaced into the evaporating dish to the measuring cylinder and record the volume, V , to 0.1 mL. The volume, V , is equal to the volume of the soil pat. After oven drying the volume is denoted by V_d .

6.4.5 Calculation, plotting and expression of results (See form 2.F of appendix A.)

Calculate the mass of wet soil, m_1 (in g), placed in the shrinkage dish from the equation:

$$m_1 = m_3 - m_2$$

where

m_2 is the mass of the shrinkage dish (in g).

m_3 is the mass of the shrinkage dish filled with wet soil (in g).

Calculate the mass of dry soil, m_d (in g), from the equation:

$$m_d = m_4 - m_2$$

where

m_4 is the mass of the shrinkage dish and dry soil (in g).

Calculate the moisture content, w_1 (in %), of the initial wet soil pat from the equation:

$$W_1 = \left(\frac{m_1 - m_d}{m_d} \right) 100$$

Calculate the shrinkage limit, w_s (in %), from the equation:

$$w_s = w_1 - \left(\frac{V_1 - V_d}{m_d} \right) 100$$

where

V_1 is the volume of the soil sample initially (in mL);

V_d is the volume of the dry soil (in mL).

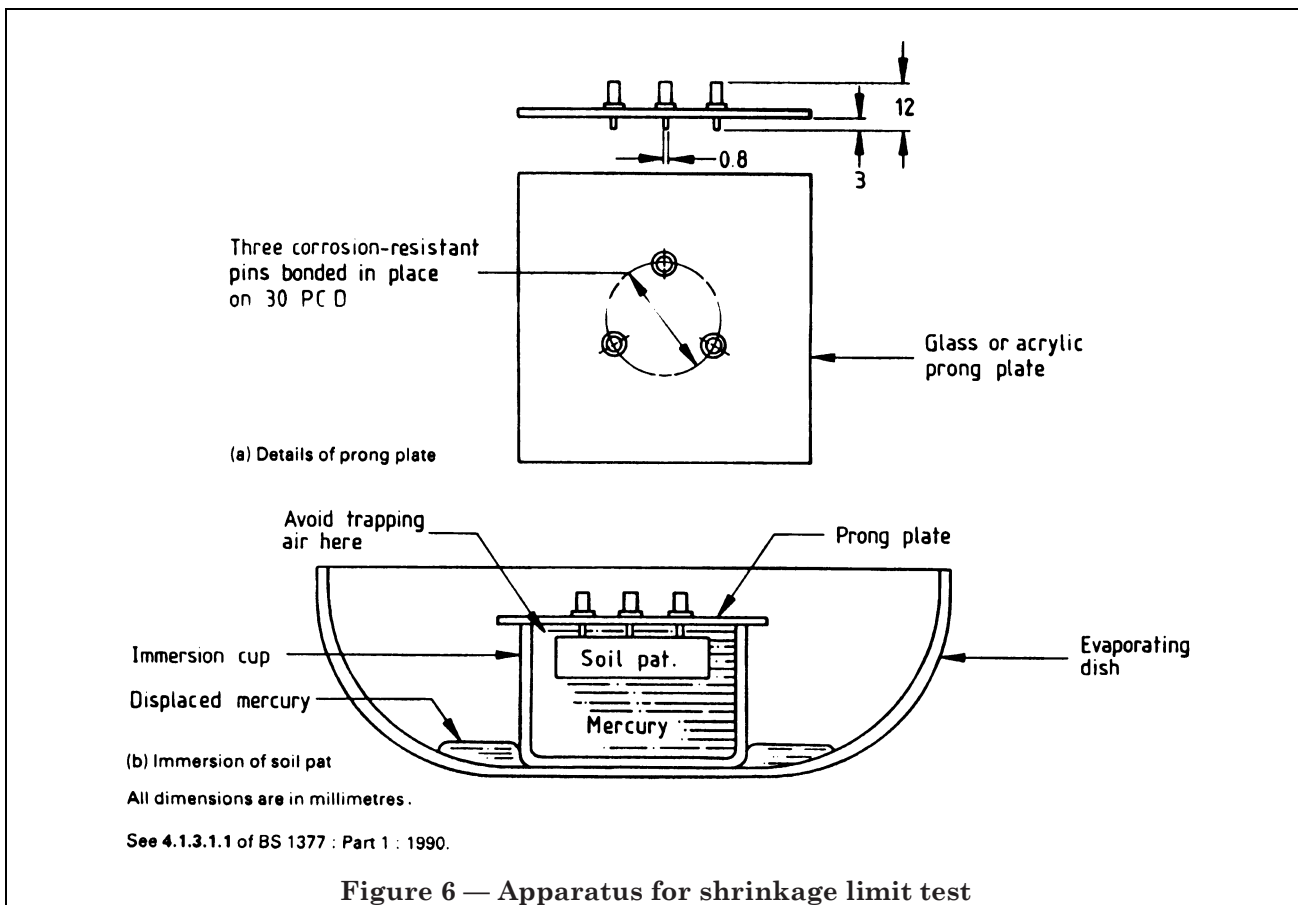

Figure 6 — Apparatus for shrinkage limit test

Calculate the shrinkage ratio, R_s , from the equation:

$$R_s = \frac{m_d}{V_d}$$

The volumetric shrinkage of the soil, V_s (in mL), corresponding to a decrease in moisture content from a given value, w (in %), to the shrinkage limit is calculated from the equation:

$$V_s = \frac{w - w_s}{R_s}$$

where

V_s is the decrease in volume (in mL) expressed as a percentage of the soil mass (in g) when dried;

w is the given moisture content of the soil (in %).

If the shrinkage curve is required proceed as follows.

From each measurement of volume and mass of the soil pat calculate the unit volume per 100 g of dry soil, U (in cm^3), from the equation:

$$U = \left(\frac{V}{m_d} \right) 100$$

When the soil was initially placed in the dish,

$$U = U_1 = \left(\frac{V_1}{m_d} \right) 100$$

In the oven-dried state,

$$U = U_d = \left(\frac{V_d}{m_d} \right) 100$$

Calculate the moisture content, w (in %), at each stage from the equation:

$$w = \left(\frac{m - m_d}{m_d} \right) 100$$

Plot values of the unit volume per 100 g dry soil, U , as ordinates against percentage moisture content, w , as abscissae, both on linear scales, as in Figure 5. The calculated value, U_d , corresponds to zero moisture content, and the calculated value, U_1 , corresponds to the initial moisture content, w_1 .

Draw the horizontal line through the point representing U_d . Draw the inclined line through the point representing U_1 which best fits the first few readings, before the relationship becomes essentially horizontal (see Figure 5). Where the two lines intersect read off the value of moisture content, w_s , which is equal to the shrinkage limit.

Express the moisture content corresponding to the shrinkage limit to the nearest whole number.

Express the shrinkage ratio to two significant figures.

6.4.6 Test report. The test report shall affirm that the test was carried out in accordance with BS 1377-2:1990 and shall include the following information:

- a) the method of test used;
- b) the shrinkage limit;
- c) whether the shrinkage limit was calculated from the final dry mass of the soil or derived from the shrinkage curve;
- d) the shrinkage ratio;
- e) the percentage of material passing the 425 μm test sieve;
- f) the history of the sample, e.g. whether tested in the natural state or after wet sieving or after any other process;
- g) the information required by clause 9 of BS 1377-1:1990.

6.5 Linear shrinkage

6.5.1 General. This method covers the determination of the linear shrinkage of the fraction of a soil sample passing a 425 μm test sieve from linear measurements on a bar of soil.

The requirements of Part 1 of this standard, as appropriate, shall apply to this test method.

6.5.2 Apparatus

6.5.2.1 Two palette knives or spatulas.

6.5.2.2 A flat, glass plate, a convenient size being 10 mm thick and about 500 mm square, or an evaporating dish of approximately 150 mm diameter.

6.5.2.3 A mould made of brass, or other suitable material complying with the essential details illustrated in Figure 7.

6.5.2.4 Silicone grease or petroleum jelly.

6.5.2.5 A drying oven capable of maintaining temperatures of 60 °C to 65 °C and of 105 °C to 110 °C.

6.5.2.6 A means of measuring a length of up to 150 mm to within 0.5 mm, such as an engineers' steel rule or vernier calipers.

6.5.2.7 Distilled water complying with 5.1 of BS 1377-1:1990.

6.5.3 Preparation of apparatus. Clean the mould thoroughly and apply a thin film of silicone grease or petroleum jelly to its inner faces to prevent the soil adhering to the mould.

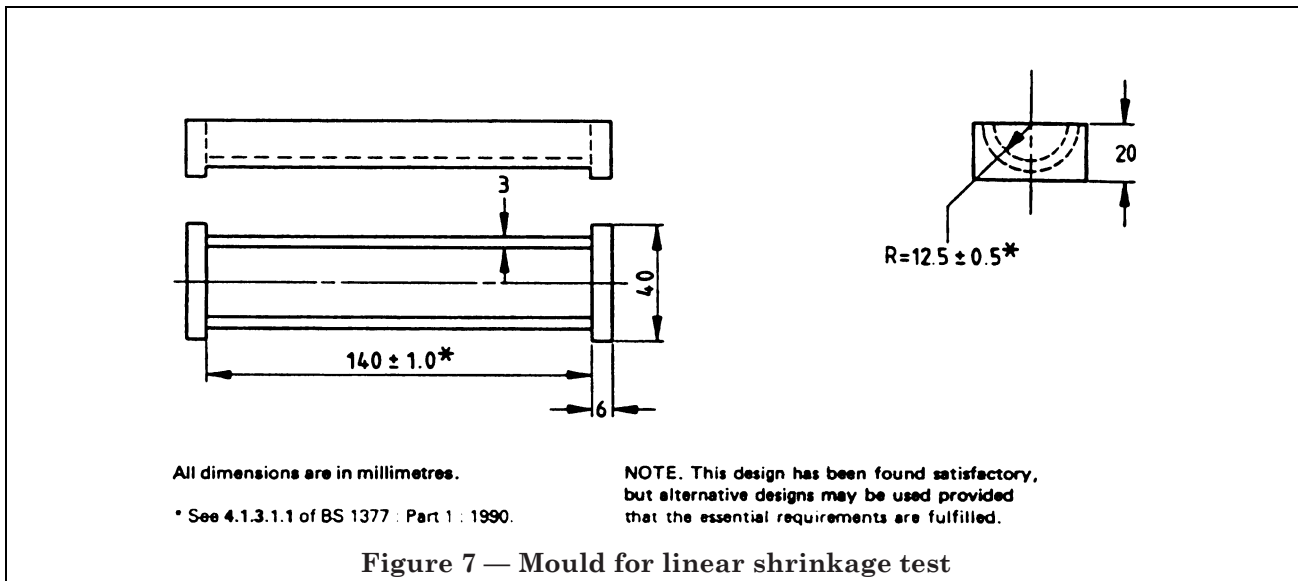

Figure 7 — Mould for linear shrinkage test

6.5.4 Procedure

6.5.4.1 Place a sample of about 150 g from the material passing through the 425 μm test sieve, obtained as specified in 4.2.4, on the flat, glass plate or in the evaporating dish. Alternatively take a sample of natural soil from which coarse particles have been removed and thoroughly mix it with distilled water in the evaporating dish to make a readily workable paste.

6.5.4.2 Add distilled water if necessary and mix thoroughly using the palette knives until the mass becomes a smooth homogeneous paste with a moisture content at about the liquid limit of the soil.

NOTE The required consistency will give a cone penetration of about 20 mm in the cone penetrometer liquid limit device, or will require about 25 bumps of the Casagrande apparatus. This moisture content is not critical to within a few per cent.

6.5.4.3 Place the soil/water mixture in the mould such that it is slightly proud of the sides of the mould. Gently jar the mould to remove any air pockets in the mixture.

6.5.4.4 Level the soil along the top of the mould with the palette knife and remove all soil adhering to the rim of the mould by wiping with a damp cloth.

6.5.4.5 Place the mould where the soil/water can air dry slowly in a position free from draughts until the soil has shrunk away from the walls of the mould. Then complete the drying, first at a temperature not exceeding 65 $^{\circ}\text{C}$ until shrinkage has largely ceased, and then at 105 $^{\circ}\text{C}$ to 110 $^{\circ}\text{C}$ to complete the drying.

6.5.4.6 Cool the mould and soil and measure the mean length of the soil bar. If the specimen has become curved during drying, remove it carefully from the mould and measure the lengths of the top and bottom surfaces. The mean of these two lengths shall be taken as the length of the oven dry specimen.

NOTE Should a specimen crack badly, or break, such that measurement is difficult, the test should be repeated at a slower drying rate.

6.5.5 Calculations and expression of results
(See form 2.G of appendix A.)

Calculate the linear shrinkage of the soil as a percentage of the original length of the specimen, L_0 (in mm), from the equation:

$$\text{Percentage of linear shrinkage} = \left(1 - \frac{L_D}{L_0}\right) 100$$

where

L_D is the length of the oven-dry specimen (in mm).

Report the linear shrinkage of the soil to the nearest whole percentage.

6.5.6 Test report. The report shall affirm that the test was carried out in accordance with BS 1377-2:1990 and shall include the following information.

- the method of test used;
- the value of the linear shrinkage of the soil;

- c) the proportion of soil that passes the 425 μm sieve test;
- d) the history of the sample, e.g. whether tested in the natural state or after wet sieving or after any other process;
- e) the information required by clause 9 of BS 1377-1:1990.

7 Determination of density

7.1 General

7.1.1 Terminology. In this standard, density is expressed in terms of mass density. The bulk density of a soil, ρ , is the mass per unit volume of the soil deposit including any water it contains. The dry density, ρ_d , is the mass of dry soil contained in a unit volume. Both are expressed in Mg/m^3 , which is numerically the same as g/cm^3 .

NOTE Weight density (unit weight), denoted by γ , is used when calculating the force exerted by a mass of soil, and is derived from the mass density by the equation:

$$\gamma = \rho g$$

where

g is the acceleration due to gravity (in m/s^2).

The value of γ (in kN/m^3) is numerically related to ρ (in Mg/m^3) by the equation:

$$\gamma = 9.807 \rho$$

7.1.2 Types of test. Three methods are specified. The first applies to soils that can be formed into a regular geometric shape, the volume of which can be calculated from linear measurements. In the second the volume of the specimen is determined by weighing it submerged in water. In the third the volume is measured by displacement of water.

7.2 Linear measurement method

7.2.1 General. This method is suitable for the determination of the density of a sample of cohesive soil of regular shape, including specimens prepared for other tests. The samples used are normally in the form of either rectangular prisms or right cylinders.

Three procedures are specified for preparing the specimen, as follows:

Procedure 1. Cutting and trimming a specimen to a suitable shape from a block sample.

Procedure 2. Extruding from a tube to form a cylindrical specimen of the same diameter as the tube.

Procedure 3. Obtaining a cylindrical specimen of smaller diameter than the sampling tube.

General comments on specimen preparation are given in clause 8 of BS 1377-1:1990.

The requirements of Part 1 of this standard, where appropriate, shall apply to this test method.

7.2.2 Apparatus. The apparatus required is as specified in 8.2 of BS 1377-1:1990, with the addition of a balance readable to 0.01 g.

7.2.3 Preparation of specimens

7.2.3.1 Procedure 1 (Specimen from block sample)

7.2.3.1.1 Cut away at least 10 mm from the outside face of the block sample, and cut out an approximately rectangular prism of soil slightly larger than the final dimensions of the specimen. If the specimen is to be used for some other test its shape shall be appropriate for that test.

7.2.3.1.2 Make the ends of the prism plane and parallel using the mitre box, or by careful trimming and checking with straightedge and try-square on the glass plate.

The test specimen may be either rectangular or cylindrical.

7.2.3.1.3 For a rectangular specimen trim the other four faces of the prism so that they are mutually perpendicular and at right angles to the end faces. Flatness and squareness shall be accurate to within 0.5 % of each dimension.

7.2.3.1.4 For a cylindrical specimen place the specimen in a soil lathe and cut off the excess soil in thin layers. Rotate the specimen between each cut until a cylindrical specimen is produced. The specimen shall not be trimmed while it is being rotated.

Remove the specimen from the lathe. Cut to the required length and make the ends plane and normal to the specimen axis to within 0.5°. A split mould may be used as a jig for this operation if of sufficient accuracy.

7.2.3.1.5 For a cylindrical specimen using a thin walled sampling tube clamp the tube firmly in the holding jig. Push the tube steadily at constant speed into the soil until the tube is nearly full, maintaining alignment of the axis of the tube with the direction of motion. Rotate the tube through 360° to shear the specimen and withdraw the tube.

Remove the specimen from the tube and trim as specified in 7.2.3.2.

7.2.3.2 Procedure 2 (Specimen direct from sample tube). The procedure is as specified in 8.3 of BS 1377-1:1990.

7.2.3.3 Procedure 3 (Specimen extruded into smaller tubes). The procedure is as specified in 8.4 of BS 1377-1:1990.

7.2.4 Measurements

7.2.4.1 Weigh the trimmed specimen to an accuracy of 0.1 % (m).

7.2.4.2 For a specimen consisting of a rectangular prism, measure and record the length of each face along the edges and near the mid-face to the nearest 0.1 mm.

7.2.4.3 For a cylindrical specimen of stiff soil, measure and record the diameter on two perpendicular diameters, at each end and near the middle, to the nearest 0.1 mm. Measure the length along three lines spaced at about 120° around the curved surface, to the nearest 0.1 mm.

7.2.4.4 For a cylindrical specimen of plastic soil, measure the internal dimensions of the mould or tube to 0.1 mm.

NOTE If the specimen is likely to deform on removal from the tube its volume should be determined from measurements of the tube diameter and length, and the distance from each end of the tube to the trimmed ends of the specimen.

7.2.5 *Calculations and expression of results.* For a rectangular prism specimen calculate the specimen density, ρ (in Mg/m³), from the equation:

$$\rho = \frac{1000m}{LBH}$$

where

L , B and H are the mean specimen dimensions determined as, specified in **7.2.4.2** (in mm);

m is the specimen mass (in g).

For a cylindrical specimen calculate the mean length, L , and the mean diameter, D . Calculate the specimen density, ρ (in Mg/m³), from the equation:

$$\rho = \frac{4000m}{\pi D^2 L}$$

where

D is the mean diameter of the specimen or of the tube or mould determined as specified in **7.2.4.3** or **7.2.4.4** (in mm);

L is the mean length of the specimen or of the tube or mould determined as specified in **7.2.4.3** or **7.2.4.4** (in mm);

m is the specimen mass (in g).

If the moisture content, w (in %), of the soil is known, calculate the dry density of the specimen, ρ_d (in Mg/m³), from the equation:

$$\rho_d = \frac{100\rho}{100 + w}$$

Express the density and dry density of the soil specimen to the nearest 0.01 Mg/m³.

Express the moisture content, if known, to two significant figures.

7.2.6 *Test report.* The test report shall affirm that the test was carried out in accordance with BS 1377-2:1990 and shall include the following information:

- the method of test used;
- the density and the dry density of the soil specimen;
- the moisture content if known;
- the information required by clause 9 of BS 1377-1:1990.

7.3 Immersion in water method

7.3.1 *General.* This method covers the determination of the bulk density and dry density of a sample of natural or compacted soil by measuring its mass in air and its apparent mass when suspended in water. The method can be employed whenever lumps of material of suitable size can be obtained.

NOTE Although the sample should preferably be cylindrical or cubical in shape, the test can be carried out quite satisfactorily on specimens of other shapes, providing no one dimension is very much smaller than the other two. However, lumps with re-entrant angles should be avoided. As the accuracy of the test depends upon the size of the specimen, it is important that the largest available specimen, compatible with the capacity of the balance, should be used.

The requirements of Part 1 of this standard, where appropriate, shall apply to this test method.

7.3.2 Apparatus

7.3.2.1 A watertight container of a suitable size.

7.3.2.2 A balance readable to 1 g.

7.3.2.3 A cradle and supporting frame similar in principle to that shown in Figure 8 which, with the frame attached to the scoop or platform of the balance, can support the cradle below the balance.

NOTE The arrangement of the cradle and supporting frame shown in Figure 8 has been found convenient but any other method which enables the specimen to be suspended in water, supported only by the scoop or platform of the balance above, would also be satisfactory. Adequate counterbalance weights should be placed on the supporting battens.

7.3.2.4 *Equipment for melting paraffin wax.*

7.3.2.5 *Apparatus for moisture content determination* as specified in **3.2**.

7.3.3 Materials

7.3.3.1 *Plasticine or putty.*

7.3.3.2 *Paraffin wax* as specified in **5.4.2** of BS 1377-1:1990.

7.3.4 Adjustment of apparatus

7.3.4.1 Support the balance with the scoop or platform over the container and with at least 300 mm clear space between the underside of the supports and the top of the container. A suitable arrangement is shown in Figure 8.

7.3.4.2 Fill the container with water to within 80 mm of the top. Then place the container in a position below the balance, and adjust the cradle and supporting frame, so that the cradle is suspended in the water without touching either the bottom or the sides of the container. Ensure that the largest specimen to be tested will be immersed completely when on the cradle.

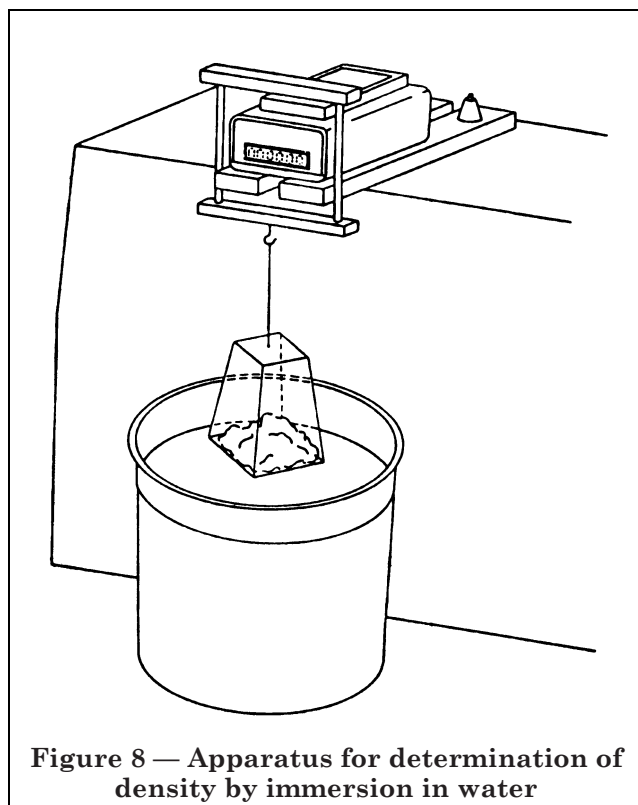

Figure 8 — Apparatus for determination of density by immersion in water

7.3.4.3 Place the counter-mass on the scale pan to bring the reading on the balance back to zero if a two-pan balance is used, or use the tare device to set the balance reading to zero.

7.3.5 Procedure

7.3.5.1 Trim the soil sample, if necessary, until a specimen is produced measuring at least 100 mm in each dimension (see note to 7.3.1). Weigh this specimen to the nearest 1 g (m_s).

7.3.5.2 Fill all the surface air voids of the specimen with a material which is insoluble in water, e.g. plasticine or putty. Cavities left by removal of stones shall not be filled. Weigh to the nearest 1 g (m_f).

NOTE Care should be taken to fill only air voids and not the holes resulting from loss of stone during collection and preparation of the specimen. In filling the voids the material used should be trimmed level with the surface of the specimen.

7.3.5.3 Coat the specimen completely by repeated dipping in molten paraffin wax. Allow the waxed specimen to cool and weigh to the nearest 1 g (m_w).

NOTE 1 Waxing of the specimen should be carried out very carefully. Surface depressions, including cavities left by stones, should be first coated with molten wax applied by brush, and allowed to set before dipping. Ensure that air bubbles are not formed under the wax. Cavities considered to be parts of existing voids, e.g. in compacted soils, due to poor compaction, should be made up with filler before waxing.

NOTE 2 To avoid shrinking and cracking of the wax coating the wax should be only just molten when applied. In the absence of a thermostatically controlled waxpot, use of a carpenter's glue pot helps to avoid overheating of the wax.

7.3.5.4 Place the waxed specimen in the cradle and suspend the cradle from the supporting frame attached to the scoop or platform of the balance. Measure the apparent mass of the specimen while suspended in water to the nearest 1 g (m_g).

NOTE When the specimen is placed in the water, supported by the cradle, care should be taken to see that no air bubbles are trapped underneath the specimen. Also, while measuring the apparent mass when suspended in water, ensure that the specimen is immersed completely. If this is not the case either the level of the water in the container should be raised or the supporting frame should be adjusted until the specimen is immersed completely. The specimen should then be removed from the cradle and the apparatus readjusted as specified in 7.3.4.2 and 7.3.4.3.

7.3.5.5 Remove the specimen from the cradle, allow it to surface dry and break it up. Take a portion of the soil which is completely free from paraffin wax, plasticine or putty and determine its moisture content, w , as specified in 3.2.

7.3.6 Calculations and expression of results (See form 2.H of appendix A.)

Calculate the volume of the test specimen, V_s (in cm^3), from the equation:

$$V_s = (m_w - m_g) - \left(\frac{m_w - m_f}{\rho_p} \right)$$

where

m_w is the mass of specimen and wax coating (in g);

m_g is the apparent mass of specimen and wax coating when suspended in water (in g);

m_f is the mass of specimen after making up surface voids with filler (in g);

ρ_p is the density of paraffin wax (in g/cm^3).

NOTE The density of the paraffin wax can be determined by procedure 1 described in 7.2.

Calculate the bulk density of the specimen, ρ (in Mg/m^3), from the equation:

$$\rho = \frac{m_s}{V_s}$$

where

m_s is the mass of the soil specimen (in g) prepared as specified in 7.3.5.1.

Calculate the dry density of the specimen, ρ_d (in Mg/m^3), from the equation:

$$\rho_d = \frac{100\rho}{100 + w}$$

where

w is the moisture content of the soil (in %).

Express the bulk density and dry density to the nearest 0.01 Mg/m^3 .

Express the moisture content to two significant figures.

7.3.7 Test report. The test report shall affirm that the test was carried out in accordance with BS 1377-2:1990 and shall include the following information:

- the method of test used;
- the bulk density and the dry density of the soil specimen;
- the moisture content;
- the information required by clause 9 of BS 1377-1:1990.

7.4 Water displacement method

7.4.1 General. This method covers the determination of the bulk density and dry density of a sample of soil by measuring its water displacement and mass. The method can be employed whenever lumps of material of suitable size can be obtained.

NOTE Although the sample should preferably be cylindrical or cubical in shape, the test can be carried out quite satisfactorily on specimens of other shapes, providing no one dimension is very much smaller than the other two. However, lumps with re-entrant angles should be avoided. As the accuracy of the test depends upon the size of the specimen, it is important that the largest available specimen compatible with the capacity of the balance and of the siphon container should be used.

The requirements of Part 1 of this standard, where appropriate, shall apply to this test method.

7.4.2 Apparatus

7.4.2.1 A cylindrical metal container with a siphon tube, of the type shown in Figure 9.

7.4.2.2 A watertight container to act as a receiver for the water siphoning over from the container specified in 7.4.2.1.

7.4.2.3 A balance readable to 1 g.

7.4.2.4 Equipment for melting paraffin wax.

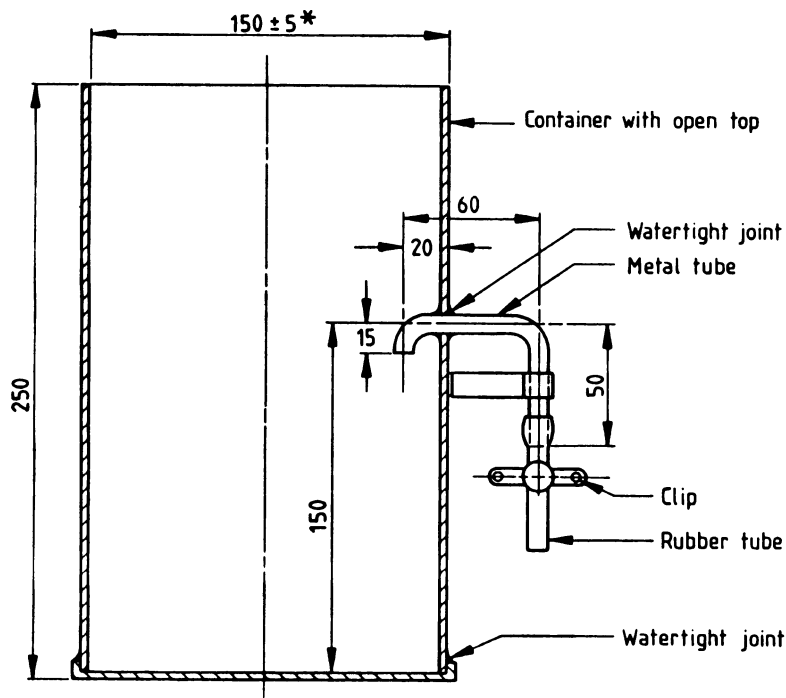

NOTE. This design has been found satisfactory, but alternative designs may be used provided that the essential requirements are fulfilled.

All dimensions are in millimetres.

* See 4.1.3.1.1 of BS 1377 : Part 1 : 1990.

Figure 9 — Apparatus for determination of density by water displacement

7.4.2.5 Apparatus for moisture content determination as specified in 3.2.

7.4.3 Materials

7.4.3.1 Plasticine or putty.

7.4.3.2 Paraffin wax as specified in 5.4.2 of BS 1377-1:1990.

7.4.4 Procedure

7.4.4.1 Trim the soil sample, if necessary, until a specimen of approximately 100 mm in each dimension is produced (see note to 7.4.1). Weigh this specimen to the nearest 1 g (m_s).

7.4.4.2 Fill all the surface air voids of the specimen with a material which is insoluble in water, e.g. plasticine or putty. Cavities left by removal of stones shall not be filled. Weigh the specimen to the nearest 1 g (m_p).

NOTE Care should be taken to fill only air voids and not the holes resulting from loss of stone during collection and preparation of the specimen. In filling the voids the material used should be trimmed level with the surface of the specimen.

7.4.4.3 Coat the specimen completely by repeated dipping in molten paraffin wax. Allow the specimen to cool and then weigh to the nearest 1 g (m_w).

NOTE 1 Waxing of the specimen should be carried out very carefully. Surface depressions, including cavities left by stones, should be first coated with molten wax applied by brush, and allowed to set before dipping. Ensure that air bubbles are not formed under the wax.

Cavities considered to be parts of existing voids, e.g. in compacted soils, due to poor compaction, should be made up with filler before waxing.

NOTE 2 To avoid shrinking and cracking of the wax coating the wax should be only just molten when applied. In the absence of a thermostatically controlled waxpot, use of a carpenter's glue pot helps to avoid overheating of the wax.

7.4.4.4 Stand the metal container on a level base and pour water into the container until the level of the liquid is well above the siphon tube. Release the clip on the rubber outlet tube to allow excess water to run to waste. Retighten the clip.

7.4.4.5 Weigh the container for receiving the water to the nearest 1 g (m_1) and then place it below the siphon outlet. Lower the specimen carefully into the container so that no portion of the specimen is projecting above the level of the siphon. Release the clip on the siphon outlet tube, allowing the displaced water to siphon over into the receiver. After all the excess water has been siphoned off, retighten the clip on the outlet tube. Then weigh the receiver and water to the nearest 1 g (m_2).

NOTE When the specimen is placed in the water in the container care should be taken to see that no air bubbles are trapped underneath the specimen.

7.4.4.6 Remove the specimen from the container, allow it to surface dry and break it up. Take a representative sample of the soil, completely free from paraffin wax, plasticine or putty, and determine its moisture content, w , as specified in 3.2.

7.4.5 Calculations and expression of results (See form 2.J of appendix A.)

Calculate the volume of the test specimen, V_s (in cm^3), from the equation:

$$V_s = (m_2 - m_1) - \left(\frac{m_w - m_f}{\rho_p} \right)$$

where

m_1 is the mass of the water receiver (in g);

m_2 is the mass of the receiver and water siphoned over into it (in g);

m_w is the mass of specimen after coating with paraffin wax (in g);

m_f is the mass of specimen after making up surface voids with filler (in g);

ρ_p is the density of paraffin wax (in g/cm^3).

NOTE The density of the paraffin wax can be determined readily by procedure described in 7.2.

Calculate the bulk density of the specimen, ρ (in Mg/m^3), from the equation:

$$\rho = \frac{m_s}{V_s}$$

where

m_s is the mass of the soil specimen (in g) prepared as specified in 7.4.4.1.

Calculate the dry density of the specimen, ρ_d (in Mg/m^3), from the equation:

$$\rho_d = \frac{100\rho}{100 + w}$$

where

w is the moisture content of the soil (in %).

Express the bulk density and dry density to the nearest 0.01 Mg/m^3 .

Express the moisture content to two significant figures.

7.4.6 Test report. The test report shall affirm that the test was carried out in accordance with BS 1377-2:1990 and shall include the following information:

- the method of test used;
- the bulk density and the dry density of the soil specimen;
- the moisture content;
- the information required by clause 9 of BS 1377-1:1990.

8 Determination of particle density

8.1 General

8.1.1 Terminology. In this standard the term particle density is used instead of the term specific gravity, which was used in previous editions of this standard, to comply with current usage in other standards. It is denoted by the symbol ρ_s . In this standard particle density is quoted in Mg/m^3 , which is numerically equal to the specific gravity.

8.1.2 Types of test. Three methods are described. The first is a gas jar method suitable for most soils including those containing gravel-sized particles. The second is the small pycnometer method which is the definitive method for soils consisting of clay, silt and sand-sized particles. The third is a pycnometer method, suitable for soils containing particles up to medium gravel size. The last is less accurate than the other two and is more suitable as a site test or when a result of lower accuracy is acceptable.

8.1.3 Limitations. Different particle sizes within a sample of soil often have different particle densities. These methods of test give the average particle density for the range of sizes, and their distribution, contained in the sample tested. In some instances it may be desirable to measure the particle density separately on separate size fractions.

8.2 Gas jar method

8.2.1 General. This method is suitable for soil containing up to 10 % of particles retained on a 37.5 mm test sieve. Coarse particles in excess of this should be broken down to less than this size before testing. If these particles contain internal voids, tests on the broken-down material could lead to results different from those given by tests on the whole material.

The requirements of Part 1 of this standard, where appropriate, shall apply to this test method.

8.2.2 Sample preparation

8.2.2.1 Sample. A sample of soil of about 1 kg mass shall be obtained as specified in 7.3 and 7.4.4 of BS 1377-1:1990. Coarse material in excess of 10 % retained on a 37.5 mm test sieve, or any particles retained on a 50 mm test sieve, shall be broken down to less than 37.5 mm size.

8.2.2.2 Test specimens. At least two specimens shall be obtained from the sample by riffing. For fine-grained soils each specimen shall be of about 200 g, and for coarse-grained soils of about 400 g. The specimens shall be oven dried, normally at 105 °C to 110 °C, and then stored in airtight containers until required.

NOTE Oven drying for the soil at 105 °C to 110 °C has been specified for convenience. If there is any reason to believe that this will change the particle density due to loss of water of hydration, the soil should be dried at no more than 80 °C. This fact should be reported.

Duplicate specimens are needed for two separate determinations of the particle density.

8.2.3 Apparatus

8.2.3.1 A gas jar, 1 L in capacity, fitted with a rubber bung.

NOTE A gas jar has been found to make a very effective pycnometer but any container of similar capacity can be used provided that it can be shaken in a mechanical shaking apparatus, and provided that the mouth can be sealed in such a way that its volume is constant.

8.2.3.2 A ground glass plate for closing the gas jar.

8.2.3.3 A mechanical shaking apparatus capable of rotating the gas jar, end over end, at about 50 r/min.

NOTE An end-over-end shaker has been specified but shaking machines giving a vibrating motion would also be suitable. The choice of shaking machine depends on the type of pycnometer used.

8.2.3.4 A balance readable to 0.1 g.

8.2.3.5 A thermometer to cover the temperature range 0 °C to 50 °C, readable to 1 °C.

8.2.3.6 A drying oven, capable of maintaining a temperature of 105 °C to 110 °C.

8.2.4 Procedure

8.2.4.1 Clean and dry the gas jar and ground glass plate and weigh them together to the nearest 0.2 g (m_1).

8.2.4.2 Transfer the first soil specimen from its sealed container directly into the gas jar. Weigh the gas jar, ground glass plate and contents to the nearest 0.2 g (m_2).

8.2.4.3 Add about 500 mL of water at a temperature within ± 2 °C of the average room temperature during the test to the soil. Insert the rubber stopper into the gas jar, and for medium- and coarse-grained soils set aside for at least 4 h.

NOTE If there is a large difference between the air temperature and water temperature, sufficient water should be drawn for the required number of tests and allowed to stand in the room in which the tests are being done until the temperature is within the given range.

8.2.4.4 At the end of this period, or immediately after the addition of water in the case of fine-grained soils, shake the gas jar by hand until the particles are in suspension.

8.2.4.5 Place the gas jar securely in the shaking apparatus and shake for a period of 20 min to 30 min.

8.2.4.6 Remove the stopper carefully and wash any soil particles adhering to the stopper or to the top of the gas jar into the jar. Disperse any froth with a fine spray of water. Add water to the gas jar to within 2 mm of the top and allow the soil to settle for a few minutes, then fill the gas jar to the brim with more water. Place the ground glass plate on the top of the jar taking care not to trap any air under the plate.

NOTE This operation may be easier if the gas jar is inclined under a slow stream of water while the ground glass plate is slid upwards over the rim.

8.2.4.7 Dry the gas jar and plate carefully on the outside and weigh the whole to the nearest 0.2 g (m_3).

8.2.4.8 Empty the gas jar, wash it out thoroughly and fill it to the brim with water at a temperature within ± 2 °C of the average room temperature. Place the ground glass plate in position taking care not to trap any air under the plate. Ensure that the water in the jar contains no air bubbles.

8.2.4.9 Dry the gas jar and plate carefully on the outside and weigh the whole to the nearest 0.2 g (m_4).

8.2.4.10 Repeat 8.2.4.1 to 8.2.4.7 using the second specimen of the same soil so that two values of particle density can be obtained. If the results differ by more than 0.03 Mg/m³ repeat the tests.

8.2.5 Calculations and expressions of results
(See form 2.K of appendix A.)

Calculate the particle density, ρ_s (in Mg/m³), from the equation:

$$\rho_s = \frac{m_2 - m_1}{(m_4 - m_1) - (m_3 - m_2)}$$

where

m_1 is the mass of gas jar and ground glass plate (in g);

m_2 is the mass of gas jar, plate and soil (in g);

m_3 is the mass of gas jar, plate, soil and water (in g);

m_4 is the mass of gas jar, plate and water (in g).

Calculate the average of the two results if they differ by no more than 0.03 Mg/m³.

Express the average value of particle density to the nearest 0.01 Mg/m³.

8.2.6 Test report. The test report shall affirm that the test was carried out in accordance with BS 1377-2:1990 and shall include the following information:

- a) the method of test used;
- b) the average value of the particle density of the soil specimen;

- c) the information required by clause 9 of BS 1377-1:1990.

8.3 Small pyknometer method

8.3.1 General. This method is suitable for soils consisting of particles finer than 2 mm. Larger particles may be ground down to smaller than this size before testing. If these particles contain internal voids, tests on the broken-down material could lead to results different from those given by tests on the whole material.

The requirements of Part 1 of this standard, where appropriate, shall apply to this test method.

8.3.2 Sample preparation

8.3.2.1 Sample. A sample of soil of about 100 g shall be obtained as specified in 7.3 and 7.4.4 of BS 1377-1:1990. Large particles shall be ground to pass a 2 mm test sieve.

8.3.2.2 Specimens. At least two specimens, each between 5 g and 10 g, shall be obtained by riffing. The specimens shall be oven dried at 105 °C to 110 °C, and then stored in airtight containers until required.

NOTE Oven drying of the soil at 105 °C to 110 °C has been specified for convenience. If there is any reason to believe that this will change the particle density due to loss of water of hydration, the soil should be dried at not more than 80 °C. This fact should be reported.

Duplicate specimens are needed for two separate determinations of particle density, which may be run concurrently.

8.3.3 Apparatus

8.3.3.1 Two 50 mL density bottles (pyknometers) with stoppers, complying with BS 733-1.

8.3.3.2 A water bath maintained at a constant temperature in the range 20 °C to 30 °C to within ± 0.2 °C.

8.3.3.3 A vacuum desiccator with protective cage.

8.3.3.4 A desiccator containing anhydrous silica gel.

8.3.3.5 A drying oven, capable of maintaining a temperature of 105 °C to 110 °C.

8.3.3.6 A balance readable to 0.001 g.

8.3.3.7 A source of vacuum, e.g. a filter pump or a vacuum pump.

8.3.3.8 A Chattaway spatula having a blade small enough to go through the neck of the density bottle, or a piece of glass rod about 150 mm long and 3 mm diameter.

8.3.3.9 A wash bottle containing air-free distilled water.

NOTE 1 Air-free distilled water may be obtained by boiling a quantity of water for at least 30 min in a container that can be sealed from the atmosphere during cooling. Take care to see that the container is strong enough to resist the reduction in pressure inside it during cooling.

NOTE 2 With non-polar materials, e.g. coal particles, the use of a wetting agent may be necessary. Add 20 % by volume of a very dilute solution of wetting agent in distilled water in the wash bottle. A longer period under vacuum may be required.

8.3.3.10 A *sample divider* of the multiple slot type (riffle box) with a 7 mm width of opening.

8.3.3.11 A *length of rubber vacuum tubing* to fit the vacuum pump and the desiccator.

8.3.4 Procedure

8.3.4.1 Clean the density bottle and stopper. Dry by rinsing with acetone or an alcohol-ether mixture and then blowing warm air through it at 105 °C to 110 °C. Weigh the bottle with the stopper to the nearest 0.001 g (m_1).

NOTE In order to avoid distortion the density bottle should not be dried by placing it in an oven.

8.3.4.2 Transfer the first soil specimen to the density bottle direct from its sealed container. Weigh the bottle, contents and stopper to the nearest 0.001 g (m_2).

8.3.4.3 Add sufficient air-free distilled water or other liquid just to cover the soil in the bottle, without disturbing the soil excessively. Place the bottle and contents, without the stopper, in the vacuum desiccator. Evacuate the desiccator gradually, reducing the pressure to about 20 mm of mercury. Take care during this operation to ensure that air trapped in the soil does not bubble too violently, which could lead to small drops of suspension being lost through the mouth of the bottle. When using a water pump, because of variations in mains pressure, take care to ensure that the required vacuum is maintained.

Leave the bottle in the evacuated desiccator for at least 1 h until no further loss of air is apparent.

NOTE With certain soils, e.g. those containing soluble salts, kerosene (paraffin oil) or white spirit may be preferred to distilled water. If one of these is used, record the fact and carry out a separate experiment to determine the density of the liquid at the temperature of the test. The equation for the particle density of the soil particles, ρ_s (in Mg/m³), given in 8.3.5 then becomes:

$$\rho_s = \frac{\rho_L(m_2 - m_1)}{(m_4 - m_1) - (m_3 - m_2)}$$

where

ρ_L is the density of the liquid used, at the constant temperature (in Mg/m³);

m_1 is the mass of density bottle (in g);

m_2 is the mass of bottle and dry soil (in g);

m_3 is the mass of bottle, soil and liquid (in g);

m_4 is the mass of bottle when full of liquid only (in g).

8.3.4.4 Release the vacuum and remove the lid of the desiccator. Stir the soil in the bottle carefully with the Chattaway spatula, or vibrate the bottle. Before removing the spatula from the bottle wash off any particles of soil adhering to the blade with a few drops of air-free liquid. Replace the lid of the desiccator and evacuate it again as specified in 8.3.4.3.

8.3.4.5 Repeat 8.3.4.3 and 8.3.4.4 until no more air is evolved from the soil.

NOTE Experience has shown that the largest source of error in the test is due to the difficulty in ensuring the complete removal of air from the sample. To obtain reliable results the soil should be left under vacuum for several hours, preferably overnight.

8.3.4.6 Remove the density bottle and contents from the desiccator and add more air-free liquid to fill the bottle. Insert the stopper and immerse the bottle up to the neck in the constant-temperature bath. Leave the bottle in the bath for at least 1 h or until the contents have attained the constant temperature of the bath.

NOTE If a constant-temperature room or cabinet is available then this procedure need not be carried out in a water bath.

8.3.4.7 If there is an apparent decrease in the volume of the liquid, remove the stopper, add more liquid to fill the bottle and replace the stopper. Return the bottle to the bath and again allow the contents to attain the constant temperature.

NOTE If surplus liquid other than water exudes through the capillary in the stopper it should be carefully absorbed on a filter paper to avoid contamination of the water bath.

8.3.4.8 Repeat 8.3.4.7 if necessary until the bottle remains completely full.

8.3.4.9 Take the stoppered bottle out of the bath, carefully wipe it dry with the minimum of handling and weigh the whole to the nearest 0.001 g (m_3).

8.3.4.10 Clean out the bottle, fill it completely with de-aerated liquid, insert the stopper and immerse in the constant temperature bath for the period specified in 8.3.4.6.

8.3.4.11 If necessary fill the bottle as specified in 8.3.4.7 and 8.3.4.8.

8.3.4.12 Take the stoppered bottle out of the bath, wipe it dry as specified in 8.3.4.9 and weigh it to the nearest 0.001 g (m_4).

NOTE If 8.3.4.10 is used to find the volume of the density bottle then the test may be carried out at any temperature provided it is constant throughout the test.

8.3.4.13 Repeat 8.3.4.1 to 8.3.4.9 using the second specimen of the same soil so that two values of particle density can be obtained. If the results differ by more than 0.03 Mg/m³ repeat the test.

NOTE 1 Many soils have a substantial proportion of heavier or lighter particles. Such soils will give erratic values for the particle density even with the greatest care in testing and a number of repeat tests may be needed to obtain a good average value.

NOTE 2 Clean quartz and flint sands generally have a specific gravity close to 2.65; low values would suggest the presence of organic matter.

8.3.5 Calculations. (See form 2.L of appendix A.)

Calculate the particle density, ρ_s (in Mg/m^3), from the equation:

$$\rho_s = \frac{m_2 - m_1}{(m_4 - m_1) - (m_3 - m_2)}$$

where

m_1 is the mass of density bottle (in g);

m_2 is the mass of bottle and dry soil (in g);

m_3 is the mass of bottle, soil and water (in g);

m_4 is the mass of bottle when full of water only (in g).

Calculate the average of the two results if they differ by no more than 0.03 Mg/m^3 .

Express the average value of the particle density to the nearest 0.01 Mg/m^3 .

8.3.6 Test report. The test report shall affirm that the test was carried out in accordance with BS 1377-2:1990 and shall include the following information:

- the method of test used;
- the average value of the particle density of the soil specimen;
- the information required by clause 9 of BS 1377-1:1990.

8.4 Large pyknometer method

8.4.1 General. This method is suitable for use in a laboratory with limited facilities. It is satisfactory for non-cohesive soils containing particles finer than 20 mm. Coarser particles should be broken down to less than this size before testing. If these particles contain internal voids, tests on the broken-down material could lead to results different from those given by tests on the whole material.

This method is less accurate than the gas jar method specified in 8.2 and is not suitable for clay soils.

The requirements of Part 1 of this standard, where appropriate, shall apply to this test method.

8.4.2 Sample preparation

8.4.2.1 Sample. A sample of soil of about 1.5 kg shall be obtained as specified in 7.3 and 7.4.4 of BS 1377-1:1990. Coarse particles retained on a 20 mm test sieve shall be broken down to less than that size.

8.4.2.2 Test specimens. At least two specimens, each of about 400 g, shall be obtained from the sample by riffing. The specimens shall be oven dried at 105°C to 110°C , and then stored in airtight containers until required.

NOTE Oven drying of the soil at 105°C to 110°C has been specified for convenience. If there is any reason to believe that this will change the particle density due to loss of water of hydration, the soil should be dried at not more than 80°C . This fact should be reported.

Duplicate specimens are needed for two separate determinations.

8.4.3 Apparatus

8.4.3.1 Pyknometer, a glass vessel of nominally 1 L capacity designed for a screw-top lid, fitted with the following:

- a corrosion-resistant screw ring;
- a conical cap of corrosion-resistant metal with a cone angle of 75° to 78° and with a hole 6 ± 0.5 mm diameter at its apex;
- a rubber or fibre sealing washer to ensure that the screw top is watertight when screwed on to the jar.

A mark shall be made on the screw top so that the screw is tightened to the same position each time and the internal volume of the pyknometer is always the same.

NOTE A suitable vessel is a 1 kg fruit preserving jar in which the glass lid normally used is replaced by the assembly described in a), b) and c) of 8.4.3.1.

8.4.3.2 A glass rod about 300 mm long and 6 mm diameter.

8.4.3.3 A balance readable to 0.5 g.

8.4.3.4 A thermometer to cover the temperature range 0°C to 50°C , readable to 1°C .

8.4.3.5 A drying oven capable of maintaining a temperature of 105°C to 110°C .

8.4.4 Procedure

8.4.4.1 Clean and dry the pyknometer and weigh the whole assembly to the nearest 0.5 g (m_1).

8.4.4.2 With the screw top removed transfer the first specimen from its sealed container directly into the jar. Weigh the jar and contents and the screw-top assembly to the nearest 0.5 g (m_2).

8.4.4.3 Add water at a temperature of within $\pm 2^\circ\text{C}$ of the average room temperature during the test to about half fill the jar. Stir the mixture thoroughly with the glass rod to remove air trapped in the soil.

NOTE If there is a large difference between the air temperature and water temperature, sufficient water should be drawn for the required number of tests and allowed to stand in the room in which the tests are being done until the temperature is within the given range.

8.4.4.4 Fit the screw cap assembly and tighten so that the reference marks coincide. Fill the pyknometer with water.

8.4.4.5 Agitate by shaking the pycnometer, or by rolling it on the bench, while holding one finger over the hole in the conical top. Allow air to escape and froth to disperse. Leave the pycnometer standing for at least 24 h at room temperature constant to within ± 2 °C.

NOTE Air may also be removed by applying suction to the hole in the cap from an efficient filter pump.

8.4.4.6 Top up the pycnometer with water so that the water surface is flush with the hole in the conical cap. Take care that air bubbles or froth are not trapped under the cap.

8.4.4.7 Dry the pycnometer on the outside and weigh the whole to the nearest 0.5 g (m_3).

8.4.4.8 Empty the pycnometer, wash it thoroughly and fill it completely with water at room temperature. Ensure that the reference marks on the screw cap coincide, that no air bubbles are entrapped (see note to 8.4.4.5), and that the water surface is flush with the hole in the conical cap.

8.4.4.9 Dry the pycnometer on the outside and weigh to the nearest 0.5 g (m_4).

8.4.4.10 Repeat 8.4.4.1 to 8.4.4.7 using the second specimen of the same soil so that two values of particle density can be obtained. If the results differ by more than 0.05 Mg/m³ repeat the tests.

8.4.5 *Calculations and expression of results*
(See Form 2.L of appendix A.)

Calculate the particle density, ρ_s (in Mg/m³), from the equation:

$$\rho_s = \frac{m_2 - m_1}{(m_4 - m_1) - (m_3 - m_2)}$$

where

m_1 is the mass of pycnometer and cap assembly (in g);

m_2 is the mass of pycnometer, cap and soil (in g);

m_3 is the mass of pycnometer, cap, soil and water (in g);

m_4 is the mass of pycnometer, cap and water (in g).

Calculate the average of the two results if they differ by no more than 0.05 Mg/m³.

Express the average value of the particle size density to the nearest 0.05 Mg/m³.

8.4.6 *Test report.* The test report shall affirm that the test was carried out in accordance with BS 1377-2:1990 and shall include the following information:

- the method of test used;
- the average value of the particle density of the soil specimen;

c) the information required by clause 9 of BS 1377-1:1990.

9 Determination of particle size distribution

9.1 General

Two methods of sieving are specified. Wet sieving is the definitive method applicable to essentially cohesionless soils. Dry sieving is suitable only for soils containing insignificant quantities of silt and clay.

Two methods of determining the size distribution of fine particles down to the clay size by sedimentation are specified, namely the pipette method and the hydrometer method, in both of which the density of the soil suspension at various intervals is measured. Combined sieving and sedimentation procedures enable a continuous particle size distribution curve of a soil to be plotted from the size of the coarsest particles down to the clay size.

9.2 Wet sieving method

9.2.1 *General.* This method covers the quantitative determination of the particle size distribution in an essentially cohesionless soil, down to the fine sand size. The combined silt and clay fraction can be obtained by difference.

The procedure given involves preparation of the sample by wet sieving to remove silt and clay-sized particles, which are rejected, followed by dry sieving of the remaining coarser material.

If the soil does not contain particles retained on a 2 mm test sieve in significant quantity, the method specified in 9.4 or 9.5 can be used.

The requirements of Part 1 of this standard, where appropriate, shall apply to this test method.

9.2.2 Apparatus

9.2.2.1 *Test sieves* having the following aperture sizes:

75 mm, 63 mm, 50 mm, 37.5 mm, 28 mm, 20 mm, 14 mm, 10 mm, 6.3 mm, 5 mm, 3.35 mm, 2 mm, 1.18 mm, 600 μ m, 425 μ m, 300 μ m, 212 μ m, 150 μ m, 63 μ m and appropriate receivers.

NOTE 1 Alternatively, test sieves complying with BS 410 having the ISO series of aperture sizes may be used.

NOTE 2 The aperture sizes of the test sieves used for the test should adequately cover the range for the particular soil used, but it will not generally be necessary to use every size for every test.

NOTE 3 Where large numbers of tests are to be carried out it may be advantageous to have two sets of sieves, one for the wet sieving and one for the dry sieving processes.

9.2.2.2 *A balance* readable to 1.0 g.

9.2.2.3 *A balance* readable to 0.1 g.

9.2.2.4 *Sample dividers*, e.g. the multiple slot type (riffle boxes).

9.2.2.5 *A drying oven* capable of maintaining a temperature of 105 °C to 110 °C.

9.2.2.6 *An evaporating dish* about 150 mm diameter.

9.2.2.7 *A corrosion-resistant tray*, a convenient size being about 300 mm square and 40 mm deep.

9.2.2.8 *Two or more large corrosion-resistant metal or plastics watertight trays* with sides about 80 mm deep, or a bucket of about 12 L capacity.

9.2.2.9 *A scoop*.

9.2.2.10 *Sieve brushes*, and a wire brush or similar stiff brush.

9.2.2.11 *Sodium hexametaphosphate*.

9.2.2.12 *A quantity of rubber tubing* about 6 mm bore.

9.2.2.13 *A sprayer* such as a small watering-can rose.

9.2.2.14 *A mechanical sieve shaker* (optional).

9.2.3 *Sample preparation*. The soil shall be prepared as specified in 7.3 and 7.4.5 of BS 1377-1:1990. The test sample shall be obtained by riffing or quartering and shall then be oven dried at 105 °C to 110 °C to give a minimum mass complying with Table 3. (See also Figure 10.)

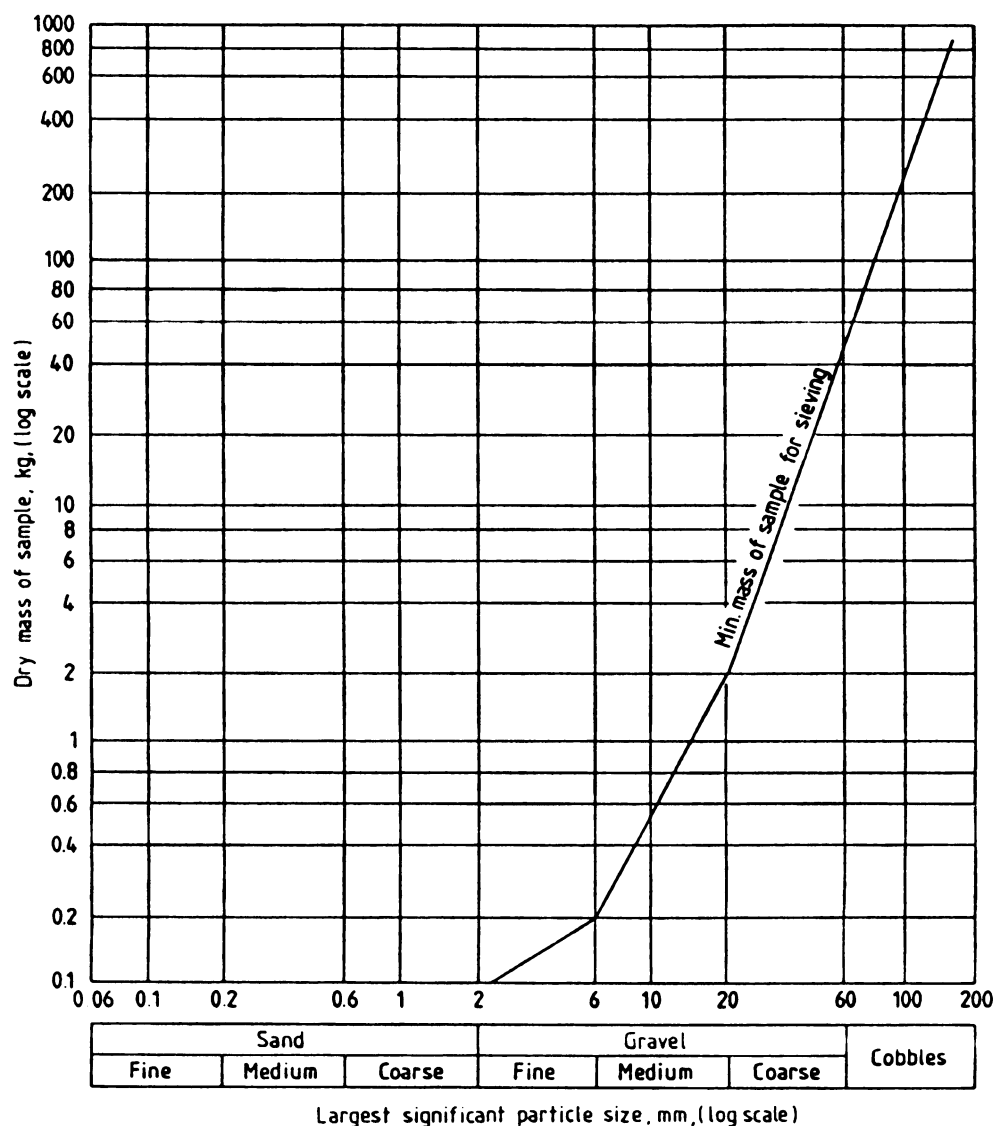

Figure 10 — Minimum mass of sample required for particle size test

If separation of the silt and clay fractions is to be carried out, or if the particle size distribution is to be extended below 63 μm , a second riffled sample shall be obtained for a fine analysis as specified in 9.4 or 9.5.

9.2.4 Procedure

9.2.4.1 Weigh the oven-dried test sample to 0.1 % of its total mass (m_1).

9.2.4.2 Place the sample on the 20 mm test sieve and brush any particles too coarse to pass through the test sieve with a wire brush or similar stiff brush until the individual particles are clean of any finer material.

NOTE 1 If adhering fine material cannot be removed easily by brushing, the following procedure may be followed.

- Remove the fine material from the coarse particles by washing.
- Dry and weigh the coarse particles to 0.1 % of their mass.
- Dry the washings, add them to the material passing the 20 mm test sieve, and mix thoroughly.

Take care when dealing with soft materials to ensure that the brushing does not remove parts of the large particles.

NOTE 2 Certain soils, e.g. tropical residual soils, have significant amounts of the clay fraction in the interstices of the larger particles. Treat these soils as specified in this method but then wash the large particles retained on the 20 mm test sieve in sodium hexametaphosphate solution; estimate the amount of clay removed and allow for it in the final calculations.

Sieve the fraction retained on the 20 mm test sieve on the appropriate larger test sieves and weigh the amount retained on each test sieve. If any test sieve becomes overloaded sieve the material on the test sieve in parts, the parts not to exceed the masses given in Table 4.

Table 3 — Mass of soil sample for sieving

Maximum size of material present in substantial proportion (more than 10 %)	Minimum mass of sampling to be taken for sieving
Test sieve aperture	
mm	kg
63	50
50	35
37.5	15
28	6
20	2
14	1
10	0.5
6.3	0.2
5	0.2
3.35	0.15
2 or smaller	0.1

Table 4 — Maximum mass of material to be retained on each test sieve at the completion of sieving

Test sieve aperture size	Maximum mass on sieve of diameter		
	450 mm	300 mm	200 mm
mm	kg	kg	g
50	10	4.5	—
37.5	8	3.5	—
28	6	2.5	—
20	4	2.0	—
14	3	1.5	—
10	2	1.0	—
6.3	1.5	0.75	—
5	1.0	0.5	—
3.35	—	—	300
2	—	—	200
1.18	—	—	100
μm			
600	—	—	75
425	—	—	75
300	—	—	50
212	—	—	50
150	—	—	40
63	—	—	25

9.2.4.3 Weigh the portion of the oven-dried material passing the 20 mm test sieve to 0.1 % of its total mass, m_2 .

Riffle that portion so that a fraction of convenient mass (about 2 kg) is obtained. Weigh the fraction to 0.1 % of its total mass, m_3 .

9.2.4.4 Spread the riffled fraction in the large tray, or place it in the bucket, and cover with water. If the soil is cohesive add sodium hexametaphosphate to the water first at a concentration of 2 g/L.

9.2.4.5 Stir the mixture well to wet the soil. Allow the soil to stand for at least 1 h in this solution, stirring frequently.

9.2.4.6 Wash the material, a little at a time, through a 2 mm test sieve nested in a 63 μm test sieve, allowing the material passing the 63 μm test sieve is virtually clear. Ensure that neither test sieve is overloaded in the process, either with solids or with water (see Table 4). The maximum amount of material initially on the 63 μm test sieve shall not exceed 150 g for a 200 mm diameter test sieve, 350 g for a 300 mm diameter test sieve or 750 g for a 450 mm diameter test sieve.

9.2.4.7 Transfer all the material retained on the sieves into a tray or evaporating dish and dry in an oven at 105 °C to 110 °C.

NOTE The retained material should not be dried on the sieve as it is detrimental to sieves to heat them.

9.2.4.8 Weigh the dried fraction when cool to 0.1 % of its total mass, m_4 .

9.2.4.9 Sieve the dried fractions through the appropriate sieves down to the 6.3 mm test sieve, using the dry sieving procedure specified in 9.3.4. Weigh the amount retained on each sieve to 0.1 % of the total dry fraction.

NOTE The 6.3 mm sieve is stated as the size at which riffing is carried out, but the sieve aperture size chosen for this operation should be appropriate to the grading of the soil. The principle remains the same, but Form 2M should be modified accordingly.

9.2.4.10 If the fraction passing the 6.3 mm test sieve is small, i.e. not more than 150 g, the sample may be sieved by dry sieving on the appropriate sieves down to and including the 63 µm test sieve. Weigh the amount retained on each sieve and any fines passing the 63 µm test sieve, m_F , to 0.1 % of the total fraction passing the 6.3 mm sieve.

NOTE 1 If a mechanical shaker is available 9.2.4.9 and 9.2.4.10 can be performed in one operation provided the test sieves are all of the same diameter. Take care to ensure that sieving is complete. The minimum period of shaking should be 10 min.

NOTE 2 The 6.3 mm sieve is stated as the size at which riffing is carried out, but the sieve aperture size chosen for this operation should be appropriate to the grading of the soil. The principle remains the same but Form M should be modified accordingly.

9.2.4.11 If the fraction passing the 6.3 mm test sieve is large, i.e. substantially greater than 150 g, weigh it (m_5), and then riffle it so that a fraction of 100 g to 150 g is obtained. Weigh this fraction, m_6 , and then sieve on the appropriate sieves down to and including the 63 µm test sieve. Weigh the amounts retained on each sieve, and any fines passing the 63 µm test sieve, m_E . If riffing is not necessary, m_6 is the same as m_5 . Weigh to 0.1 % of the total fraction passing the 6.3 mm sieve.

NOTE The 6.3 mm sieve is stated as the size at which riffing is carried out, but the sieve aperture size chosen for this operation should be appropriate to the grading of the soil. The principle remains the same, but Form 2M should be modified accordingly.

9.2.5 Calculations and expression of results
(See form 2.M appendix A.)

9.2.5.1 For samples containing particles larger than 20 mm in size, calculate the sum of the masses retained on each sieve together with the mass m_2 passing the 20 mm sieve.

If this total differs from the initial dry mass m_1 by more than 1 % this stage of the test shall be repeated.

Calculate the proportion by mass of material retained on each of the coarse series of sieves as a percentage of m_1 .

For example:

Percentage retained on 28 mm sieve =

$$\left\{ \frac{m(28 \text{ mm})}{m_1} \right\} 100$$

9.2.5.2 Calculate the sum of the masses retained on each sieve together with the mass m_5 passing the 6.3 mm sieve. If this total differs from the dried riffled mass m_4 by more than 1 % this stage of the test shall be repeated.

Calculate the corrected mass of material retained on each of the sieves between 20 mm and 6.3 mm by multiplying by m_2/m_3 , then calculate this mass as a percentage of m_1 .

For example:

$$\begin{aligned} &\text{Percentage retained on 10 mm sieve} \\ &= m(10 \text{ mm}) \left(\frac{m_2}{m_3} \right) \left(\frac{100}{m_1} \right) \end{aligned}$$

9.2.5.3 Calculate the sum of the masses retained on each sieve together with the mass m_F or m_E passing the 63 µm sieve. If this total differs from the dried riffled mass m_6 by more than 1 % this stage of the test shall be repeated.

Calculate the corrected mass of material retained on each of the sieves finer than the 6.3 mm sieve by

multiplying by $\left(\frac{m_5}{m_6} \right) \left(\frac{m_2}{m_3} \right)$ and then calculate this mass as a percentage of m_1 .

For example:

Percentage retained on

$$300 \text{ } \mu\text{m sieve} = m(300 \mu\text{m}) \left(\frac{m_5}{m_6} \right) \left(\frac{m_2}{m_3} \right) \left(\frac{100}{m_1} \right)$$

9.2.5.4 Calculate the cumulative percentages by mass of the sample passing each of the sieves from the general relationship:

$$(\% \text{ passing this sieve}) = (\% \text{ passing previous sieve}) - (\% \text{ retained on this sieve})$$

9.2.5.5 Calculate the fraction passing the 63 µm test sieve by difference. The mass of fines lost by washing in 9.2.4.6 is equal to $(m_3 - m_4)$. To this is added the mass of any fine material (m_F) passing the 63 µm sieve when dry sieved (see 9.2.4.10), and the percentage finer than 63 µm is equal to:

$$\left\{ \frac{(m_3 - m_4) + m_F}{m_3} \right\} \left(\frac{m_2}{m_1} \right) 100$$

If the sample was subdivided (see 9.2.4.11) the mass of fines, m_E , is increased in the ratio m_5/m_6 , and the percentage finer than 63 μm is equal to:

$$\left\{ \frac{(m_3 - m_4) + \left(\frac{m_E \times m_5}{m_6} \right)}{m_3} \right\} \left(\frac{m_2}{m_1} \right) 100$$

for m_1 see 9.2.4.1;

for m_2 see 9.2.4.3;

for m_3 see 9.2.4.3;

for m_4 see 9.2.4.8;

for m_5 see 9.2.4.11;

for m_6 see 9.2.4.11;

for m_E see 9.2.4.11;

for m_F see 9.2.4.10.

Express the results on a semi-logarithmic chart of the type shown as Form 2.N in appendix A. Alternatively, the results may be reported in the form of a table showing, to the nearest 1 %, the percentage by mass passing each of the sieves used.

9.2.6 Test report. The test report shall affirm that the test was carried out in accordance with BS 1377-2:1990 and shall include the following information:

- the method of test used;
- the particle size distribution curve or the tabulated percentages, as specified in 9.2.5.5;
- the information required by clause 9 of BS 1377-1:1990.

9.3 Dry sieving method

9.3.1 General. This method covers the quantitative determination of the particle size distribution in a cohesionless soil down to the fine-sand size. This method shall not be used unless it has been shown that for the type of material under test it gives the same results as the method of analysis by wet sieving. In cases of doubt the method shall not be used.

The requirements of Part 1 of this standard, where appropriate, shall apply to this test method.

9.3.2 Apparatus

9.3.2.1 Test sieves having the following aperture sizes may be used:

75 mm, 63 mm, 50 mm, 37.5 mm, 28 mm, 20 mm, 14 mm, 10 mm, 6.3 mm, 5 mm, 3.35 mm, 2 mm, 1.18 mm, 600 μm , 425 μm , 300 μm , 212 μm , 150 μm , 63 μm and appropriate receivers.

NOTE 1 Alternatively, test sieves complying with BS 410 having the ISO series of aperture sizes may be used.

NOTE 2 The sizes of test sieves used for the test should cover adequately the range for the particular soil used, but it will not generally be necessary to use every size for every test.

9.3.2.2 A balance readable to 1.0 g.

9.3.2.3 A balance readable to 0.1 g.

9.3.2.4 Sample dividers, e.g. the multiple slot type (riffle box).

9.3.2.5 A drying oven capable of maintaining a temperature of 105 °C to 110 °C.

9.3.2.6 A tray.

9.3.2.7 A scoop.

9.3.2.8 Sieve brushes.

9.3.2.9 A mechanical sieve shaker (optional).

9.3.3 Sample preparation. The soil shall be prepared as specified in 7.3 and 7.4.5 of BS 1377-1:1990. The test sample shall be obtained by riffling or quartering and shall then be oven dried at 105 °C to 110 °C to give a minimum mass complying with Table 3. (See also Figure 10.)

9.3.4 Procedure

9.3.4.1 Weigh the oven-dried sample to 0.1 % of its total mass (m_1).

9.3.4.2 Fit the largest size test sieve appropriate to the maximum size of material present to the receiver and place the sample on the sieve (see BS 1796).

NOTE If the assembly is not too heavy to handle, several sieves, in order of size, may be fitted together and used at the same time.

9.3.4.3 Agitate the test sieve so that the sample rolls in an irregular motion over the test sieve. Particles may be hand placed to see if they will fall through but they shall not be pushed through. Make sure that only individual particles are retained. Weigh the amount retained on the test sieve to 0.1 % of its total mass.

9.3.4.4 Transfer the material retained in the receiver to a tray and fit the receiver to the next largest sized test sieve. Place the contents of the tray on the sieve and repeat 9.3.4.3.

NOTE If the mass of the sample passing the 20 mm test sieve is substantially greater than 2 kg the sample should be riffled to obtain a sample of about 2 kg and care taken to make due allowance in the calculation for the subdivision of the original sample.

9.3.4.5 Repeat 9.3.4.3 and 9.3.4.4 through all the test sieve sizes used.

NOTE If a mechanical shaker is available 9.3.4.3 and 9.3.4.4 can be performed in one operation provided the test sieves are all of the same diameter. Take care to ensure that sieving is complete. The minimum period of shaking should be 10 min.

9.3.4.6 If any test sieve becomes overloaded sieve the material on the test sieve in parts, the parts not to exceed the masses given in Table 4.

9.3.5 Calculations (See form 2.M of appendix A.)

Calculate the percentage by mass of material retained on each test sieve.

Obtain the percentage passing the 63 μm test sieve by difference, and check by weighing the amount in the receiver.

Calculate the cumulative percentage (by mass of the total sample) passing each of the sieves.

Express the results obtained on a semi-logarithmic chart of the type shown as Form 2.N in appendix A. Alternatively, the results may be reported as a table showing, to the nearest 1 %, the percentage by mass passing each of the sieves used.

9.3.6 Test report. The test report shall affirm that the test was carried out in accordance with BS 1377-2:1990 and shall include the following information.

- the method of test used;
- the particle size distribution curve, or the tabulated percentages, as specified in 9.3.5;
- the information required by clause 9 of BS 1377-1:1990.

9.4 Sedimentation by the pipette method

9.4.1 General. This method covers the quantitative determination of the particle size distribution in a soil from the coarse sand size to the clay size (about 2 μm). (See note.) The procedure enables the percentages of coarse, medium and fine silt, and clay, to be determined. These percentages can be linked to the curve obtained by sieving to provide a single curve for the whole material.

The analysis of data requires that the particle density of the soil specimen is known or can be assumed.

The test as specified is not usually necessary if less than 10 % of the material passes the 63 μm test sieve as specified in 9.2.

NOTE If the sample has been wet sieved down to the 63 μm test sieve size then only the material passing the 63 μm test sieve need be used to carry out this test, thus eliminating the necessity of repeating the determinations of the same fractions.

The requirements of Part 1 of this standard, where appropriate, shall apply to this test method.

9.4.2 Apparatus

9.4.2.1 A sampling pipette of the type illustrated in Figure 11, fitted with a pressure and suction inlet, and having a capacity of approximately 10 mL. The pipette shall be so arranged that it can be inserted to a fixed depth into a cylinder (see 9.4.2.2), when the latter is immersed in a constant-temperature bath (see Figure 12).

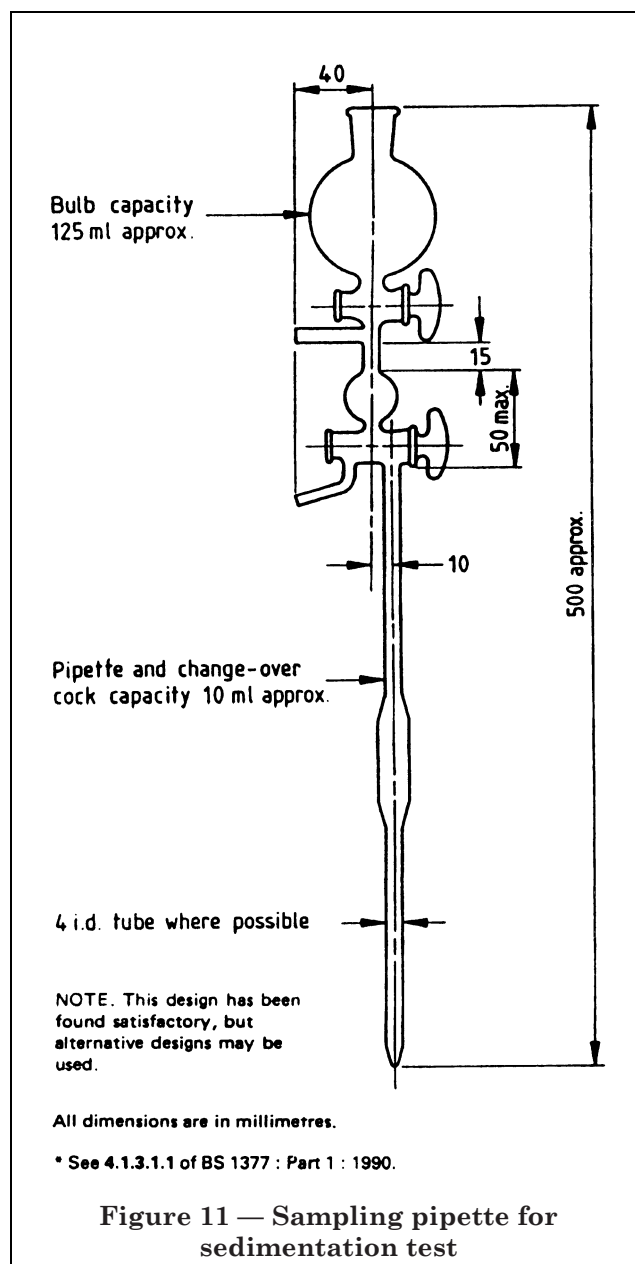

9.4.2.2 Two glass cylinders, each approximately 50 mm diameter and approximately 350 mm long graduated at 500 \pm 10 mL volume, with rubber bungs to fit.

9.4.2.3 Nine glass weighing bottles, approximately 25 mm in diameter and 50 mm high fitted with ground glass stoppers. The masses of the bottles shall be known to the nearest 0.001 g.

9.4.2.4 A constant-temperature bath capable of being maintained at 25 $^{\circ}\text{C}$, to an accuracy of \pm 0.5 $^{\circ}\text{C}$ into which the cylinder can be immersed up to the 500 mL mark. The bath shall not vibrate the sample.

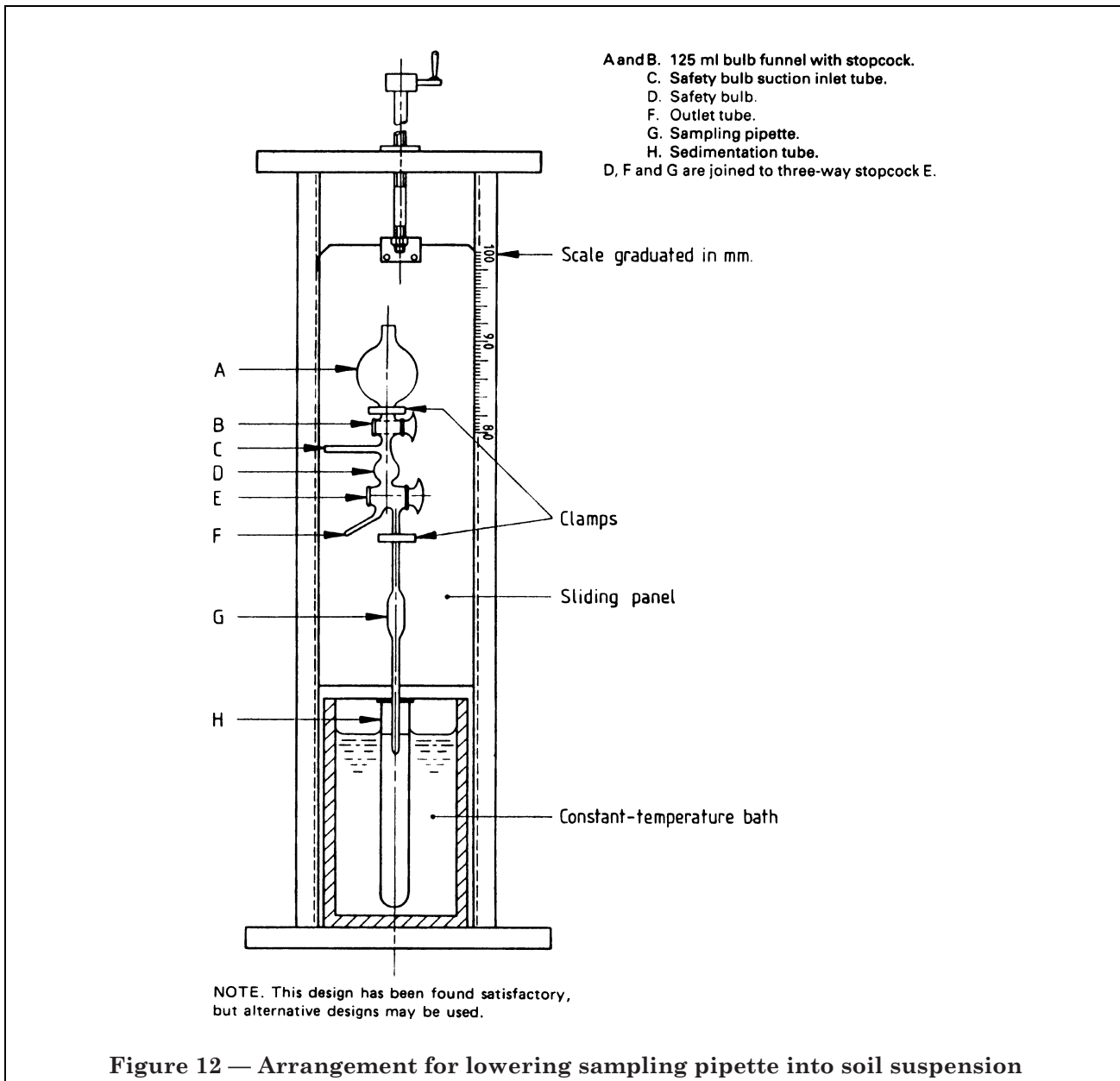

9.4.2.5 A mechanical shaker capable of keeping 30 g of soil and 150 mL of water in continuous suspension. A device which rotates the container end-over-end at 30 r/min to 60 r/min is satisfactory.

9.4.2.6 Test sieves as follows: 2 mm; 600 μm , 212 μm , 63 μm and appropriate receivers.

9.4.2.7 A sample divider of the multiple slot type (riffle box).

9.4.2.8 A balance readable to 0.001 g.

9.4.2.9 A drying oven, capable of maintaining a temperature of 60 °C to 65 °C and of 105 °C to 110 °C.

9.4.2.10 A stopclock or stopwatch readable to 1 s.

9.4.2.11 A desiccator containing anhydrous silica gel.

9.4.2.12 A 650 mL or 1 L conical flask and a cover glass to fit, and a small beaker.

9.4.2.13 A centrifuge capable of holding 250 mL capacity bottles, used only if chemical pretreatment is specified (see 9.4.2.21).

NOTE Centrifuging is the most rapid and convenient method of recovering the soil after pretreatment. However if a centrifuge is not available the alternative equipment and procedure may be used instead.

9.4.2.14 250 mL capacity polypropylene centrifuge bottles, used only if chemical pretreatment is specified.

9.4.2.15 A 100 mL measuring cylinder.

9.4.2.16 A 25 mL pipette or measuring cylinder.

9.4.2.17 A glass filter funnel about 100 mm in diameter.

9.4.2.18 A wash bottle containing distilled water complying with 5.1 of BS 1377-1:1990.

9.4.2.19 A length of glass rod, 150 mm to 200 mm long and 4 mm to 5 mm in diameter, fitted at one end with a rubber policeman.

9.4.2.20 Electric hotplate or bunsen burner with tripod and gauze.

9.4.2.21 The following items are alternatives to 9.4.2.13 and 9.4.2.14 and shall be used only if chemical pretreatment is specified. (See note to 9.4.2.13.)

9.4.2.21.1 Buchner funnel, 150 mm in diameter.

9.4.2.21.2 Glass filter flask of about 1 L capacity with rubber bung to take the funnel.

9.4.2.21.3 Filter papers, to fit the funnel¹⁾.

9.4.2.21.4 An evaporating dish, about 150 mm in diameter.

9.4.2.21.5 A source of vacuum.

9.4.2.21.6 Vacuum tubing.

9.4.3 Reagents

9.4.3.1 Hydrogen peroxide. A 20 volume solution.

9.4.3.2 Sodium hexametaphosphate solution. Dissolve 33 g of sodium hexametaphosphate and 7 g of sodium carbonate in distilled water to make 1 L of solution. This solution is unstable and shall be freshly prepared approximately once a month. The date of preparation shall be recorded on the bottle.

NOTE Sodium hexametaphosphate has been specified as the dispersing agent in view of the success with which it has been employed in the analysis of a large number of soils. However, it has been found to be ineffective when dealing with certain highly aggregated soils. In such cases the incomplete dispersion obtained is indicated by the formation of relatively large crumbs or flocs of soil which fall rapidly through the water leaving a sharply defined, clear layer above the suspension. When this occurs allow the soil to settle to the bottom of the cylinder and decant as much of the supernatant liquid as possible. Add a further 25 mL of dispersing agent, shake well and make up to 500 mL. If flocculation still occurs, some other method of dispersion should be tried.

9.4.4 Calibrations

9.4.4.1 Calibration of sampling pipette

9.4.4.1.1 Clean the sampling pipette thoroughly, dry it and immerse the nozzle in distilled water. Close the tap B and open tap E to pipette G (see Figure 12).

9.4.4.1.2 By means of a rubber tube attached to C, suck water up into the pipette until it rises above E. Close tap E, and remove the pipette from the water. Pour off surplus water drawn up into the cavity above E through F into the small beaker.

9.4.4.1.3 Discharge the water contained in the pipette and tap E into a glass weighing bottle of known mass, and determine the mass. From this mass calculate the internal volume, V_p (in mL), of the pipette and the tap to the nearest 0.05 mL.

9.4.4.1.4 Make three determinations of the volume as above and take the average value as V_p (in mL).

9.4.4.2 Dispersing agent correction

9.4.4.2.1 This procedure shall be followed when a fresh batch of dispersant solution is used. Between any of the times at which samples are taken from the sedimentation cylinder (see 9.4.6.3), take a sample of V_p (in mL) from the cylinder containing the dispersant solution using the pipette. Following the procedure specified in 9.4.6.3.5 to 9.4.6.3.11 except that there is no need to time the sampling operation and the depth of the sampling is not important.

9.4.4.2.2 Determine the mass of solid residue in the sample to 0.001 g (m_r).

9.4.5 Sample preparation

9.4.5.1 The soil shall be prepared as specified in 7.3 and 7.4.5 of BS 1377-1:1990.

NOTE 1 Oven drying of some soils, in particular some tropical soils, can change the particle size properties. Where drying is likely to cause significant changes the soil should not be dried. The dry mass in this case should be calculated using the water content and mass of the test sample. Where it is known from precedent that oven drying does not affect the particle size properties of the soil the test sample may be oven dried.

NOTE 2 Difficulty may be experienced with certain tropical soils in removing all the finer fractions from the material retained on the 2 mm test sieve. In such cases it may be necessary to use a dispersing agent as in 9.2 and to wet sieve the material retained on the 2 mm test sieve. It should be dry sieved as far as possible first to reduce the amount of suspension to be handled as it will have to be filtered, washed, dried and added to the rest of the material before the pretreatment process.

9.4.5.2 The dry mass of soil required depends on the type of soil. Appropriate quantities are about 30 g for a sandy soil and 12 g for a clay or silt.

NOTE Stokes' Law applies to a single sphere falling in a large body of liquid. It is not applicable to a highly concentrated suspension, when the particles are close enough to influence each other. It has been established that if the mass of solid matter in the suspension is not too large, the deviation from Stokes' Law is negligible.

9.4.5.3 Weigh the test sample to 0.001 g and obtain its initial dry mass (m_0).

9.4.5.4 Place the test sample in the wide-mouthed conical flask.

¹⁾ Whatman No. 50 are found to be suitable.

9.4.6 Procedure. If pretreatment with hydrogen peroxide is not required, omit **9.4.6.1** and proceed from **9.4.6.2**.

9.4.6.1 Pretreatment for organic matter

9.4.6.1.1 This procedure shall be followed only when organic matter is present in the soil in significant quantity.

NOTE Pretreatment with hydrogen peroxide should normally be omitted when testing inorganic soils. When organic matter is present in significant quantity, i.e. 0.5 % or more, and its effect on the results is uncertain, parallel tests should be carried out on identical specimens with and without pretreatment. Soils rich in manganese oxides, or sulphides, may react violently with hydrogen peroxide, especially when heated.

9.4.6.1.2 Weigh the test sample to 0.001 g (m_0).

9.4.6.1.3 Place the test sample in the conical flask.

9.4.6.1.4 Add 50 mL of distilled water, and gently boil the soil suspension to reduce the volume to about 40 mL.

9.4.6.1.5 After cooling, add 75 mL of hydrogen peroxide and stir the mixture gently with a glass rod. Cover it with a cover glass and allow to stand overnight.

9.4.6.1.6 Gently heat the suspension in the conical flask, taking care to avoid frothing over. Stir or agitate the contents frequently.

9.4.6.1.7 As soon as vigorous frothing has subsided reduce the volume to about 50 mL by boiling. With very organic soils additional peroxide may be required to complete the oxidation.

9.4.6.1.8 If a centrifuge is used omit **9.4.6.1.13** to **9.4.6.1.16**. If a centrifuge is not used omit **9.4.6.1.9** to **9.4.6.1.12** inclusive.

9.4.6.1.9 Weigh the centrifuge bottle with its stopper to the nearest 0.001 g. Transfer the contents of the flask to the centrifuge bottle taking care not to lose any soil.

NOTE Centrifuging is the most rapid and convenient method of recovering the soil after pretreatment. However, if a centrifuge is not available the alternative equipment and procedure may be used instead.

9.4.6.1.10 Adjust the volume of water in the bottle to about 200 mL, stopper the bottle and centrifuge for 15 min at about 2 000 r/min.

9.4.6.1.11 Decant the clear supernatant liquid, place the bottle and its contents in the oven maintained at 60 °C to 65 °C and allow to dry to constant mass as described in **3.2.3.3.2**.

9.4.6.1.12 Replace the stopper, allow to cool in the desiccator and reweigh when cool. Determine the mass of dry pretreated soil (m_p) to 0.001 g by difference. The dried soil is now ready for dispersion as specified in **9.4.6.2**.

NOTE Extreme care is needed with the procedure from this point on, to avoid any loss of material.

9.4.6.1.13 If a centrifuge is not used transfer the contents of the conical flask on to a filter paper on a Buchner funnel. Rinse the flask with distilled water to ensure that no soil particles are lost.

9.4.6.1.14 Filter under vacuum and thoroughly wash the soil retained on the filter paper with distilled water.

9.4.6.1.15 Using a jet of distilled water, transfer the soil from the filter paper to the weighed evaporating dish, ensuring that no material is lost. Dry in an oven at 60 °C to 65 °C, cool in the desiccator and weigh again. Determine the mass of dry pretreated soil, m_p , to the nearest 0.001 g, by difference.

9.4.6.1.16 Transfer the dried soil to a conical flask for dispersion as specified in **9.4.6.2**.

9.4.6.2 Dispersion

9.4.6.2.1 Add 100 mL of the distilled water to the soil in the centrifuge bottle or conical flask. Shake vigorously until all the soil is in suspension, then add 25 mL of the dispersant solution from a pipette.

9.4.6.2.2 Shake the bottle or flask in the mechanical shaking device for at least 4 h or overnight when convenient. Alternatively, when a conical flask is used, the suspension may be agitated by the blade of a vibrating stirrer.

NOTE When dealing with soils which may be broken down by the shaking technique, e.g. some shales, a reduced period of shaking should be adopted, i.e. less than 4 h.

9.4.6.2.3 Transfer the suspension from the bottle or flask to the 63 μm test sieve placed on the receiver, and wash the soil in the sieve using a jet of distilled water from the wash bottle. The amount of water used during this operation shall not exceed 500 mL.

9.4.6.2.4 Transfer the suspension that has passed through the sieve to the 500 mL cylinder and make up to 500 mL with distilled water. Use this suspension for the sedimentation analysis specified in **9.4.6.3**.

9.4.6.2.5 Transfer the material retained on the 63 μm test sieve to an evaporating dish and dry in the oven maintained at 105 °C to 110 °C.

9.4.6.2.6 When cool, resieve this material on the sieves down to the 63 μm size, as specified in **9.3.4**. Weigh the material retained on each sieve to 0.1 % of total mass.

9.4.6.2.7 Add any material passing the 63 μm test sieve to the sedimentation cylinder.

NOTE In the wet sieving operation for the separation of sand particles, grains with diameters just slightly smaller than the apertures of the 63 μm test sieve tend to be retained due to the surface tension of the water held between the sieve meshes. The absence of such particles from the suspension is not detrimental to the subsequent sedimentation provided that they form only a small proportion of the total sample. If it is found that a large part of the sample passes the 63 μm test sieve during dry sieving operation, the material passing should be added to the suspension in the measuring cylinder prior to the sedimentation.

9.4.6.3 Sedimentation

9.4.6.3.1 Insert the rubber bung into the cylinder containing the soil suspension, shake it and place it in the constant-temperature bath so that it is immersed in water up to the 500 mL graduation mark.

9.4.6.3.2 Add 25 mL of the dispersant solution from a pipette or measuring cylinder to the second 500 mL sedimentation cylinder and dilute with distilled water up to the 500 mL graduation mark. Insert the rubber bung and place this cylinder in the constant-temperature bath alongside the first.

9.4.6.3.3 After at least 1 h, or when the cylinders and contents have reached the temperature of the bath, take out the cylinders, shake them vigorously applying about 120 end-over-end cycles in 2 min and immediately replace them in the bath.

9.4.6.3.4 At the instant the cylinder with the soil suspension is replaced upright in the bath, start the timer. Remove the rubber bungs carefully and lay them lightly on the top of each cylinder.

NOTE Froth on the surface of the suspension can be dispersed by adding two drops of methylated spirit.

9.4.6.3.5 About 15 s before a sample is due to be taken (see Table 5), lower the pipette, with tap E closed (see Figure 12) vertically into the soil suspension until the end is 100 ± 1 mm below the water surface. Take great care to avoid turbulence in the suspension. This operation shall take about 10 s.

Table 5 — Pipette sampling times and equivalent particle diameters

Particle density of silt and clay fraction Mg/m ³	Times after shaking of starting sampling operation					
	1st sample		2nd sample		3rd sample	
	min	s	min	s	h	min
2.50	4	30	50	30	7	35
2.55	4	20	49	0	7	21
2.60	4	10	47	30	7	7
2.65	4	5	46	0	6	54
2.70	4	0	44	30	6	42
2.75	3	50	43	30	6	30
2.80	3	40	42	0	6	20
2.85	3	35	41	0	6	10
2.90	3	30	40	0	6	0
2.95	3	25	39	0	5	50
3.00	3	20	38	0	5	41
3.05	3	15	37	0	5	33
3.10	3	10	36	0	5	25
3.15	3	5	35	0	5	18
3.20	3	0	34	30	5	10
Equivalent particle diameter	0.02 mm		0.006 mm		0.002 mm	

9.4.6.3.6 Open tap E so that a sample of soil suspension, V_p (in mL), is drawn up into the pipette. Close the tap when the pipette and the bore in the tap E are filled with the suspension. The sampling operation shall take about 10 s to complete.

9.4.6.3.7 Withdraw the pipette from the suspension cylinder, taking about 10 s to complete this operation.

9.4.6.3.8 During the sampling operation (see 9.4.6.3.6) a small amount of the suspension may have been drawn up into the bulb D above the bore of tap E. Run this surplus into a beaker down the outlet tube F by opening the tap E so that D and F are connected. Wash out with distilled water from the bulb funnel A into D and out through F until no suspension remains in this part of the system.

9.4.6.3.9 Place a weighing bottle of known mass, measured to 0.001 g, under the end of the pipette and open tap E so that the contents of the pipette are delivered into the bottle. Wash any suspension left on the inner walls of the pipette into the weighing bottle by allowing distilled water from the bulb A to run through B, D and E into the pipette G and then into the weighing bottle.

9.4.6.3.10 Place the weighing bottle and contents in the oven maintained at 105 °C to 110 °C and evaporate the sample to dryness.

9.4.6.3.11 Cool in the desiccator, weigh the bottle and contents to the nearest 0.001 g.

9.4.6.3.12 Determine the mass of solid material in the sample to 0.001 g.

9.4.6.3.13 Carry out 9.4.6.3.5 to 9.4.6.3.12 twice more at the times specified in Table 5. The successive masses of the solid material determined in 9.4.6.3.12 are denoted by m_1 , m_2 , m_3 .

NOTE If required, additional readings, making a total of not more than six, may be taken to give a good spread of points over the silt particle size range, 0.06 mm to 0.002 mm, when plotted on a logarithmic scale.

9.4.7 Calculations and expression of results
(See form 2.P in appendix A.)

9.4.7.1 Fine sieving

9.4.7.1.1 Calculate the proportion of soil retained on each sieve as a percentage of the dry mass of soil used, m (in g), where

$m = m_o$ if pretreatment was omitted;

For example: $m = m_p$ if the soil was pretreated as described in 9.4.6.1.

$$\text{Percentage retained on the } 600 \mu\text{m test sieve} = \frac{m(600 \mu\text{m})}{m} 100$$

9.4.7.1.2 Calculate the cumulative percentages by mass passing each of the sieves from the general relationship:

$$\begin{aligned} & \text{(Cumulative \% passing this sieve)} \\ &= \text{(cumulative \% passing previous sieve)} \\ & - \text{(\% retained on this sieve).} \end{aligned}$$

9.4.7.2 Sedimentation

9.4.7.2.1 Calculate the mass of solid material, W_1 , W_2 , etc. (in g), in 500 mL of suspension for each pipette sampling time from the equation:

$$W_1, W_2, \text{ etc.} = \left(\frac{m_1 \text{ or } m_2, \text{ etc.}}{V_p} \right) 500$$

where

m_1 , m_2 , etc. are the masses of material from the first, second, etc. sampling (in g);

V_p is the calibrated volume of the pipette (in mL).

Similarly the mass of solid material in 500 mL of dispersant solution, W_r (in g), is given by the equation:

$$W_r = \left(\frac{m_r}{V_p} \right) 500$$

where

m_r is the mass of residue as determined in 9.4.4.2.2.

9.4.7.2.2 Obtain the equivalent particle diameter, D (in mm), for each sampling operation from the bottom line of Table 5.

NOTE If required, additional readings, making a total of not more than six, may be taken to give a good spread of points over the silt particle size range, 0.06 mm to 0.002 mm, when plotted on a logarithmic scale. The equivalent particle diameter, D (in mm), for each sampling operation is calculated from the equation:

$$D = 0.005531 \sqrt{\frac{\eta H}{(\rho_t - \rho_s) t}}$$

where

η is the dynamic viscosity of water at the test temperature (in mPa s) as listed in Table 7;

H is the sampling depth (in mm);

ρ_t is the density of the liquid (water with dispersant) containing the soil suspension (in Mg/m³);

ρ_s is the mean particle density (in Mg/m³);

t is the pipette sampling time (in min);

0.005531 is a constant.

9.4.7.2.3 Calculate the percentage by mass, K , of particles smaller than each equivalent particle diameter, D (in mm), from the equation:

$$K = \left\{ \frac{(W_1, W_2, \text{ etc.} - W_r)}{m} \right\} 100$$

where

m is the mass of dry soil used (in g).

Express the results of the sedimentation analysis, and of the sieving analysis if appropriate, by plotting on a semi-logarithmic chart of the type shown as Form 2.N in appendix A, in the form of a continuous curve.

Alternatively, express the results in terms of various size fractions in the form of a table showing, to the nearest 1 %, the percentage finer than each fraction.

9.4.8 Test report. The test report shall affirm that the test was carried out in accordance with BS 1377-2:1990 and shall include the following information:

- the method of test used;
- the results of the sedimentation analysis;
- the results of the sieving analysis, if appropriate;
- the method of pretreatment;
- the information required by clause 9 of BS 1377-1:1990.

9.5 Sedimentation by the hydrometer method

9.5.1 General. This method covers the quantitative determination of the particle size distribution in a soil from the coarse sand size to the clay size.

NOTE If the sample has been wet sieved down to the 63 μ m test sieve size then only the material passing the 63 μ m test sieve need be used to carry out this test, thus eliminating the necessity of repeating the determinations of the same fractions.

The analysis of data requires that the particle density of the soil specimen is known or can be assumed.

The test as described is not usually necessary if less than 10 % of the material passes the 63 μ m test sieve when measured as specified in 9.2.

The requirements of Part 1 of this standard, where appropriate, shall apply to this test method.

9.5.2 Apparatus

9.5.2.1 A hydrometer of the type illustrated in Figure 13 and otherwise fulfilling the following requirements of BS 718.

The bulb and stem shall be made of glass as free as possible from visible defects. The glass shall be resistant to chemicals and shall be well annealed.

Where a solid loading material is used it shall be fixed in the bottom part of the hydrometer by means of a cementing material which does not soften if heated to 80 °C. Where mercury is the loading material it shall be confined in the bottom part of the hydrometer.

9.5.2.13 A centrifuge capable of holding 250 mL capacity bottles, used only if chemical pretreatment is specified. (See 9.5.2.21.)

NOTE Centrifuging is the most rapid and convenient method of recovering the soil after pretreatment. However if a centrifuge is not available the alternative equipment and procedure may be used instead.

9.5.2.14 250 mL capacity polypropylene centrifuge bottles, used only if chemical pretreatment is specified.

9.5.2.15 Two measuring cylinders, of capacity 100 mL and 500 mL.

9.5.2.16 A wash bottle containing distilled water complying with 5.1 of BS 1377-1:1990.

9.5.2.17 A length of glass rod about 150 mm to 200 mm long and 5 mm in diameter.

9.5.2.18 A constant-temperature bath capable of being maintained at 25 °C, to an accuracy of ± 0.5 °C into which the sedimentation cylinder can be immersed up to the 1 L mark. The bath shall not vibrate the sample.

9.5.2.19 Pipettes, or measuring cylinders of capacity 100 mL and 50 mL.

9.5.2.20 Electric hotplate, or bunsen burner with tripod and gauze.

9.5.2.21 The following items are alternatives to 9.5.2.13 and 9.5.2.14 and shall be used only if chemical pretreatment is specified (see note to 9.5.2.13).

9.5.2.21.1 Buchner funnel, 150 mm in diameter.

9.5.2.21.2 Glass vacuum filter flask, of about 1 L capacity with rubber bung, to take the funnel.

9.5.2.21.3 Filter papers, to fit the funnel²⁾.

9.5.2.21.4 An evaporating dish, about 150 mm in diameter.

9.5.2.21.5 A source of vacuum.

9.5.2.21.6 Vacuum tubing.

9.5.3 Reagents

9.5.3.1 Hydrogen peroxide. A 20-volume solution.

9.5.3.2 Sodium hexametaphosphate solution. Dissolve 33 g of sodium hexametaphosphate and 7 g of sodium carbonate in distilled water to make 1 L of solution. This solution is unstable and shall be freshly prepared once a month. The date of preparation shall be recorded on the bottle (see note 3 to 9.4.3.2).

9.5.4 Calibrations

9.5.4.1 Volume calibration of hydrometer.

Determine the volume of the hydrometer bulb, V_h , as follows:

Weigh the hydrometer to the nearest 0.1 g.

Record the mass in grams as the volume of the hydrometer in millilitres. This includes the volume of the bulb plus the volume of the stem below the 1.000 graduation mark. For practical purposes the error due to the inclusion of this stem volume may be neglected.

9.5.4.2 Scale calibration of hydrometer

9.5.4.2.1 Measure the distance, L (in mm), from the 100 mL scale marking to the 1 000 mL scale marking on the sedimentation cylinder, to the nearest millimetre. For a cylinder with a scale mark only at 1 000 mL, determine the 100 mL level by adding a measured 100 mL (or 100 g) of water.

9.5.4.2.2 Measure and record the distances from the lowest calibration mark on the stem of the hydrometer to each of the other major calibration marks, R_h .

9.5.4.2.3 Measure and record the distance, N , from the neck of the bulb to the nearest calibration mark. The distance, H , corresponding to a reading, R_h , is equal to the sum of the distances measured in 9.5.4.2.2 and 9.5.4.2.3, ($N + d_1$, $N + d_2$, etc., see Figure 14).

9.5.4.2.4 Measure and record the distance, h , from the neck to the bottom of the bulb as the height of the bulb.

9.5.4.2.5 Calculate the effective depth, H_R (in mm), corresponding to each of the major calibration marks, R_h , from the equation:

$$H_R = H + \frac{1}{2} \left(h - \frac{V_h}{900} L \right)$$

where

H is the length from the neck of bulb to graduation

R_h (in mm) (see Figure 14);

h is the length of the bulb, or twice the length from the neck of the bulb to its centre of volume (in mm);

V_h is the volume of hydrometer bulb (in mL);

L is the distance between the 100 mL and the 1 000 mL scale markings of the sedimentation cylinder (in mm).

NOTE The formula in 9.5.4.2.5 and Figure 14 assume a symmetrical bulb with its centre of volume located at $h/2$ below the neck. If an asymmetrical bulb is used, the centre of volume can be determined with sufficient accuracy by projecting the shape of the bulb on to a sheet of paper and finding the centre of gravity of the projected area. In the formula h is then replaced by $2h_g$, i.e. twice the length from the neck of the bulb to its centre of volume.

²⁾ Whatman NO. 50 are found to be suitable.

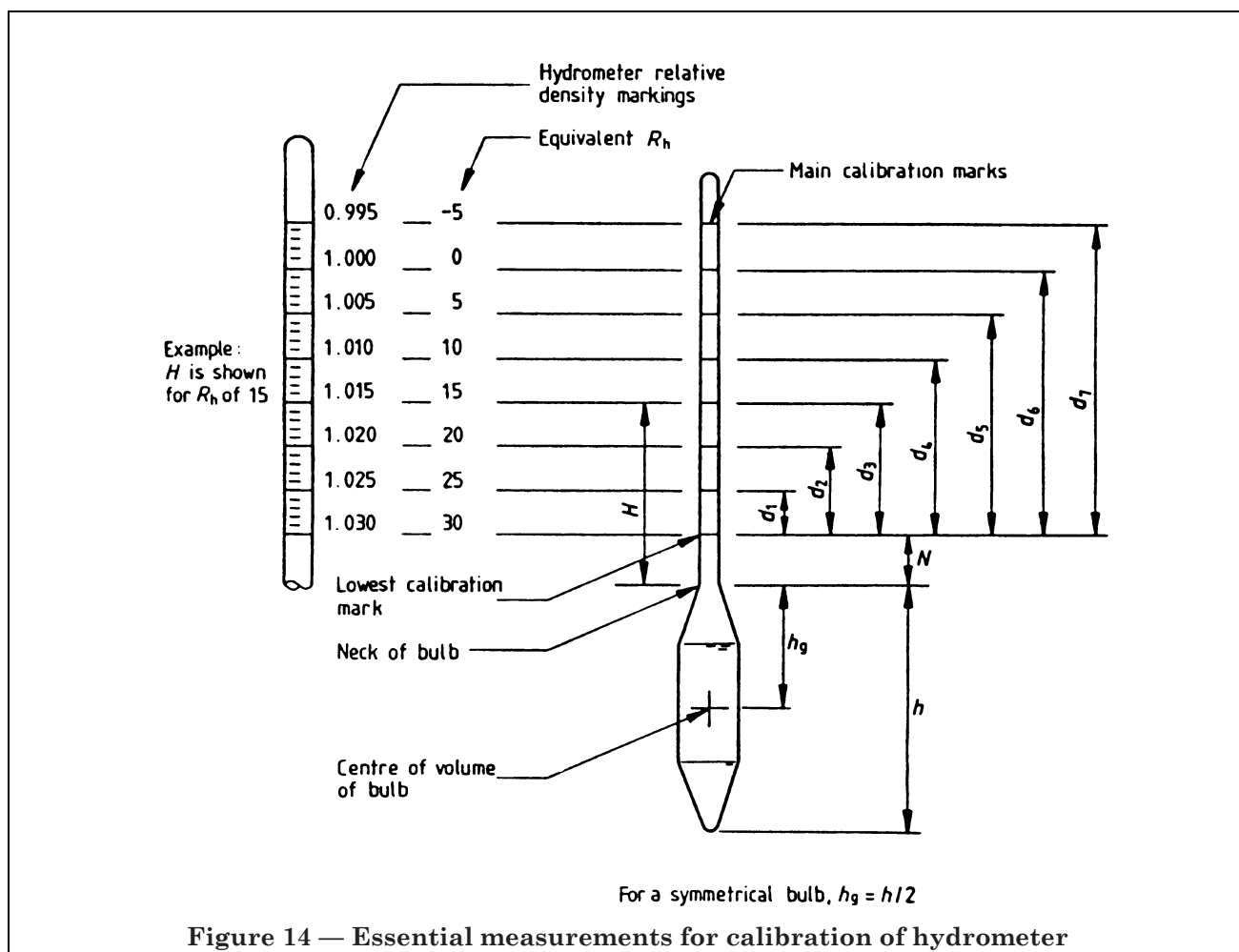

9.5.4.2.6 Plot the relationship between H_R and R_h as a smooth curve.

NOTE This relationship gives the effective depth of the suspension, the relative density of which is given by the hydrometer reading. It allows for the rise of the liquid in the graduated cylinder.

If the calibration curve is linear the relationship may be expressed as an equation of the form:

$$H_R = j_1 + j_2 R_h$$

where

J_1 is the intercept on the H_r axis corresponding to

$$R_h = 0;$$

J_2 is the slope of the line always negative

R_h is any hydrometer specific gravity reading (see Figure 14) consisting of the decimal part only with the decimal point moved three places to the right.

Record the identification number of the hydrometer on the calibration readings and graph.

9.5.4.3 Meniscus correction

9.5.4.3.1 Insert the hydrometer in a 1 L cylinder containing about 800 mL water.

9.5.4.3.2 By placing the eye slightly below the plane of the surface of the liquid and then raising it slowly until the surface seen as an ellipse becomes a straight line, determine the point where the plane intersects the hydrometer scale.

NOTE In order to obtain an accurate reading on the hydrometer scale the stem has to be perfectly clean so that the meniscus round the stem can be fully developed.

9.5.4.3.3 By placing the eye slightly above the plane of the surface of the liquid, determine the point where the upper limit of the meniscus intersects the hydrometer scale.

9.5.4.3.4 Record the difference between the two readings in **9.5.4.3.2** and **9.5.4.3.3** above as the meniscus correction, C_m .

NOTE Hydrometers are calibrated to read correctly at the surface of a liquid. However, soil suspensions are not transparent enough to permit a reading to be taken at the surface, and the reading, R_h' , has to be made at the upper rim of the meniscus. The meniscus correction, C_m , which has to be added to R_h' in order to obtain R_h , the true reading, is a constant for each hydrometer.

9.5.5 Sample preparation

9.5.5.1 The soil shall be prepared in accordance with **7.3** and **7.4.5** of BS 1377-1:1990.

NOTE 1 Oven drying of some soils, in particular some tropical soils, can change the particle size properties. Where drying is likely to cause significant changes the soil should not be dried. The dry mass in this case should be calculated using the water content and mass of the test sample. Where it is known from precedent that oven drying does not affect the particle size properties of the soil the test sample may be oven dried.

NOTE 2 Difficulty may be experienced with certain tropical soils in removing all the finer fractions from the material retained on the 2 mm test sieve. In such cases it may be necessary to use a dispersing agent as in **9.2** and to wet sieve the material retained on the 2 mm test sieve. It should be dry sieved as far as possible first to reduce the amount of suspension to be handled as it will have to be filtered, washed, dried and added to the rest of the material before the pretreatment process.

9.5.5.2 The dry mass of soil required depends on the type of soil.

NOTE 1 Appropriate quantities are about 100 g for a sandy soil and 50 g for a silt soil and 30 g for a clay soil.

NOTE 2 Stokes' Law applies to a single sphere falling in a large body of liquid. It is not applicable to a highly concentrated suspension, when the particles are close enough to influence each other. It has been established that if the mass of solid matter in the suspension is not too large, the deviation from Stokes' Law is negligible. If the hydrometer reading remains high for a lengthy period this indicates an excessive quantity of solid particles and the test should be repeated with a smaller initial sample.

9.5.5.3 Weigh the test sample to 0.01 g and obtain its initial dry mass, m_0 .

9.5.5.4 Place the test sample in the wide-mouthed conical flask.

9.5.6 Procedure. If pretreatment with hydrogen peroxide is not required, omit **9.5.6.1** and proceed to **9.5.6.2**.

9.5.6.1 Pretreatment for organic matter

9.5.6.1.1 This procedure shall be followed only when organic matter is present in the soil in significant quantity.

NOTE Pretreatment with hydrogen peroxide should normally be omitted when testing inorganic soils. When organic matter is present in significant quantity, i.e. 0.5 % or more, and its effect on the results is uncertain, parallel tests should be carried out on identical specimens with and without pretreatment.

9.5.6.1.2 Weigh the test sample to 0.01 g (m_0).

9.5.6.1.3 Place the test sample in the wide-mouthed conical flask.

9.5.6.1.4 Add 150 mL of hydrogen peroxide and stir the mixture gently with a glass rod for a few minutes. Cover it with a cover glass and leave to stand overnight. Gently heat the mixture in the conical flask, taking care to avoid frothing over. Stir the contents of the flask periodically.

9.5.6.1.5 As soon as vigorous frothing has subsided reduce the volume to about 50 mL by boiling. With very organic soils additional peroxide may be required to complete the oxidation.

9.5.6.1.6 If a centrifuge is used omit **9.5.6.1.11** to **9.5.6.1.13**. If a centrifuge is not used omit **9.5.6.1.7** to **9.5.6.1.10** inclusive.

9.5.6.1.7 Weigh the centrifuge bottle with its stopper to the nearest 0.01 g. Transfer the contents of the flask to the centrifuge bottle taking care not to lose any soil (see note to **9.5.2.13**).

9.5.6.1.8 Adjust the volume of water in the bottle to about 200 mL, stopper the bottle and centrifuge for 15 min at about 2 000 r/min.

9.5.6.1.9 Decant the clear supernatant liquid, place the bottle and its contents in the oven maintained at 60 °C to 65 °C and allow to dry to constant mass as described in **3.2.3.3.2**.

9.5.6.1.10 Replace the stopper, allow to cool in the desiccator and reweigh when cool. Determine the mass of dry pretreated soil, m_p , to 0.01 g by difference. The dried soil is now ready for dispersion as specified in **9.5.6.2**.

NOTE Extreme care is necessary from this point on to avoid any loss of material.

9.5.6.1.11 If a centrifuge is not used transfer the contents of the conical flask on to a filter paper on a Buchner funnel. Rinse the flask with distilled water to ensure that no soil particles are lost.

9.5.6.1.12 Filter under vacuum and thoroughly wash the soil retained on the filter paper with distilled water.

9.5.6.1.13 Using a jet of distilled water, transfer the soil from the filter paper to the weighed evaporating dish, ensuring that no material is lost. Dry in an oven at 60 °C to 65 °C, cool in the desiccator and weigh again. Determine the mass of dry pretreated soil, m_p , to the nearest 0.01 g, by difference.

9.5.6.1.14 Transfer the dried soil to a conical flask for dispersion as specified in **9.5.6.2**.

9.5.6.2 Dispersion

NOTE The experimental details described here using sodium hexametaphosphate as the dispersing agent have been found suitable for a very large number of soils occurring in the UK and abroad.

Certain very strongly aggregated soils may not be dispersed completely by the technique described, and it may be found necessary to add additional amounts of this or other dispersing agents. In such cases the incomplete dispersion obtained is indicated by the formation of relatively large crumbs or flocs of soil which fall rapidly through the water leaving a sharply defined, clear layer above the suspension. When this occurs decant as much of the supernatant liquid as possible, add a further 100 mL of dispersing agent, shake well and make up to 1 L with water. If flocculation still occurs some other method of dispersion should be used.

9.5.6.2.1 Add 100 mL of the dispersant solution from a pipette to the soil in the centrifuge bottle or conical flask. Shake the mixture thoroughly until all the soil is in suspension.

9.5.6.2.2 Shake the bottle or flask in the mechanical shaking device for at least 4 h, or overnight when convenient. Alternatively, when a conical flask is used, the suspension may be agitated by the blade of a vibrating stirrer.

NOTE When dealing with soils which may be broken down by the shaking technique, e.g. some shales, a reduced period of shaking should be adopted, i.e. less than 4 h.

9.5.6.2.3 Transfer the suspension from the bottle or flask to the 63 μm test sieve placed on the receiver, and wash the soil in the sieve using a jet of distilled water from the wash bottle. The amount of water used during this operation shall not exceed 500 mL.

9.5.6.2.4 Transfer the suspension that has passed through the sieve to the 1 L measuring cylinder and make up to the 1 L graduation mark with distilled water. Use this suspension for the sedimentation analysis specified in **9.5.6.3**.

9.5.6.2.5 Transfer the material retained on the 63 μm test sieve to an evaporating dish and dry in the oven maintained at 105 °C to 110 °C.

9.5.6.2.6 When cool, resieve this material on the sieves down to the 63 μm size, as specified in **9.3.4**. Weigh the material retained on each sieve to 0.01 g.

9.5.6.2.7 Add any material passing the 63 μm test sieve to the measuring cylinder.

NOTE In the wet sieving operation for the separation of sand particles, grains with diameters just slightly smaller than the apertures of the 63 μm test sieve tend to be retained due to the surface tension of the water held between the sieve meshes. The absence of such particles from the suspension is not detrimental to the subsequent sedimentation provided that they form only a small proportion of the total sample. If it is found that a large part of the sample passes the 63 μm test sieve during the dry sieving operation, the material passing shall be added to the suspension in the measuring cylinder prior to the sedimentation.

9.5.6.3 Sedimentation

NOTE See note to **9.5.5.2**.

9.5.6.3.1 Insert the rubber bung into the cylinder containing the soil suspension, shake it and place it in the constant-temperature bath so that it is immersed in water at least up to the 1 L graduation mark.

9.5.6.3.2 Add 100 mL of the dispersant solution from a pipette or measuring cylinder to the second 1 L sedimentation cylinder and dilute with distilled water to exactly 1 L. Insert the rubber bung and place this cylinder in the constant-temperature bath alongside the first.

9.5.6.3.3 After at least 1 h, or when the cylinders and contents have reached the temperature of the bath, take out the cylinder containing the dispersant solution, shake it thoroughly and replace it in the bath. Take out the cylinder containing the soil suspension, shake it vigorously end-over-end about 60 times in 2 min and then immediately replace it in the bath.

9.5.6.3.4 At the instant the cylinder with the soil suspension is replaced upright in the bath, start the timer. Remove the rubber bungs carefully from the cylinders.

9.5.6.3.5 Immerse the hydrometer in the suspension to a depth slightly below its floating position and allow it to float freely.

NOTE Froth on the surface of the suspension can be dispersed by adding two drops of methylated spirit.

9.5.6.3.6 Take hydrometer readings at the upper rim of the meniscus after periods of 0.5 min, 1 min, 2 min and 4 min. Record the relevant readings as shown in Table 6. (See form 2.Q of appendix A.)

9.5.6.3.7 Remove the hydrometer slowly, rinse in distilled water and place it in the cylinder of distilled water with dispersant at the same temperature as the soil suspension. Observe and record the top of the meniscus reading, R_0 .

9.5.6.3.8 Reinsert the hydrometer in the soil suspension and take and record readings after periods of 8 min, 30 min, 2 h, 8 h, and 24 h from the start of sedimentation, and twice during the following day if appropriate. The precise times are not critical provided that the exact time period is recorded. Insert the hydrometer slowly about 15 s before a reading is due.

NOTE 1 The test should normally continue until the percentage finer than about 2 μm can be determined. In most cases if the correct amount of soil has been used this will be reached within about 24 h.

NOTE 2 A greater or lesser number of readings (but not less than three) may be acceptable. The minimum of three readings should enable the percentages of fine, medium and coarse silt to be determined.

Insert and withdraw the hydrometer before and after taking each reading very carefully to avoid disturbing the suspension unnecessarily. Allow 10 s for each operation. Avoid vibration of the sample.

Table 6 — Hydrometer test data

1	2	3	4	5	6	7	8	9	10
Date	Time	Elapsed time t (min)	Temperature T (°C)	Reading R_h	$R_h' + C_m = R_h$	H_r (mm)	D (mm)	$R_h' - R_o' = R_d$	K (%)
<p>t is the elapsed time from the start of sedimentation (in min);</p> <p>T the temperature of the suspension at that time (in °C);</p> <p>R_h' is the hydrometer reading at the upper rim of the meniscus, consisting of the decimal part only with the decimal point moved three places to the right. For example, a hydrometer reading of 1.0325 would be recorded as an R_h value of 32.5;</p> <p>C_m is the meniscus correction;</p> <p>H_r is the effective depth (in mm) corresponding to R_h, obtained from the calibration curve;</p> <p>D is the equivalent particle diameter (in mm);</p> <p>R_o' is the hydrometer reading at the upper rim of the meniscus in the dispersant solution (in mm);</p> <p>K is the percentage by mass of particles less than D;</p> <p>R_d is the modified hydrometer reading.</p>									

9.5.6.3.9 Observe and record the temperature of the suspension once during the first 15 min and then after every subsequent reading. Read the temperature to an accuracy of ± 0.5 °C. If the temperature varies by more than ± 1 °C take another hydrometer reading in the dispersant solution as specified in **9.5.6.3.7**.

9.5.7 Calculations and expression of results
(See Table 6 and form 2.Q of appendix A.)

9.5.7.1 Fine sieving

9.5.7.1.1 Calculate the proportion of soil retained on each sieve as a percentage of the dry mass of soil used, m (in g), m

where

$$m = m_o \text{ if pretreatment was omitted;}$$

$$m = m_p \text{ if the soil was pretreated as described in 9.5.6.1.}$$

For example:

Percentage retained on the 600 μm test sieve

$$= \left(\frac{m (600 \mu\text{m})}{m} \right) 100$$

9.5.7.1.2 Calculate the cumulative percentages by mass passing each of the sieves from the general relationship:

$$\begin{aligned} & (\text{Cumulative \% passing this sieve}) \\ &= (\text{cumulative \% passing previous sieve}) - \\ & (\% \text{ retained on this sieve}) \end{aligned}$$

9.5.7.2 Sedimentation

9.5.7.2.1 Calculate the true hydrometer reading, R_h (in mm), from the equation:

$$R_h = R_h' + C_m$$

where

C_m is the meniscus correction derived as specified in **9.5.4.3**;

R_h' is the observed hydrometer reading.

Enter the values in column 6 of Table 6.

9.5.7.2.2 Obtain the effective depth, H_r (in mm), at which the density of the suspension is measured, corresponding to the reading, R_h , from the hydrometer scale calibration curve derived as specified in **9.5.4.2**, either by reading off from the curve or by calculation from its equation. Enter the value of H_r in column 7 of Table 6.

9.5.7.2.3 Calculate the equivalent particle diameter, D (in mm), from the equation:

$$D = 0.005531 \sqrt{\frac{\eta H_r}{(\rho_s - 1) t}}$$

where

η is the dynamic viscosity of water at the test temperature (in mPa s) as shown in Table 7;

H_r is the effective depth at which the density of the suspension is measured (in mm);

ρ_s is the particle density (in Mg/m^3);

t is the elapsed time (in min);

0.005531 is a constant.

Record the value of D , calculated from each set of readings, as shown in column 8 of Table 6.

NOTE Alternatively the value of D may be determined by using a nomographic chart for the application of Stokes' Law. These charts are available commercially.

Table 7 — Viscosity of water

Temperature T °C	Viscosity of water η mPa s
10	1.304
15	1.137
20	1.002
25	0.891
30	0.798
NOTE Intermediate values may be obtained by interpolation.	

9.5.7.2.4 Calculate the modified hydrometer reading, R_d , from the equation:

$$R_d = R_h' - R_o'$$

where

R_o' is the hydrometer reading at the upper rim of the meniscus in the dispersant solution.

Enter the value of R_d as shown in column 9 of Table 6.

NOTE If the density of the dispersant solution is less than 1 000g/mL, R_o' will be negative.

9.5.7.2.5 Calculate the percentage by mass, K , of particles smaller than the corresponding equivalent particle diameter, D (in mm), from the equation:

$$K = \left\{ \frac{100 \rho_s}{m(\rho_s - 1)} \right\} R_d$$

where

m is the mass of the dry soil used (in g).

NOTE The total dry mass, m , of the sample used for the test is inserted here whether or not any particles were retained on the 63 μm test sieve.

Enter the value of K corresponding to each value of D as shown in column 10 of Table 6.

Express the results of the sedimentation analysis, and of the sieving analysis if appropriate, by plotting on a semi-logarithmic chart of the type shown as Form 2.N in appendix A, in the form of a continuous curve.

Alternatively, express the results in terms of various size fractions in the form of a table showing, to the nearest 1 %, the percentage of each of the fractions defined in the glossary.

9.5.8 Test report. The test report shall affirm that the test was carried out in accordance with BS 1377-2:1990 and shall include the following information:

- the method of test used;
- the results of the sedimentation analysis;
- the results of the sieve analysis if appropriate;
- the method of pretreatment;
- the information required by clause 9 of BS 1377-1:1990.

Appendix A Typical test data and calculation forms

These test sheets are given as examples only, other suitable forms may be used.

Form 2.A. Moisture content

Form 2.B. Saturation moisture content of chalk

Form 2.C. Liquid limit (cone penetrometer) and plastic limit

Form 2.D. Liquid limit (Casagrande method) and plastic limit

Form 2.E. Shrinkage limit (cylindrical specimen)

Form 2.F. Shrinkage limit (disc specimen)

Form 2.G. Linear shrinkage

Form 2.H. Density by immersion in water

Form 2.J. Density by water displacement

Form 2.K. Particle density (gas jar)

Form 2.L. Particle density (pycnometer)

Form 2.M. Particle size distribution (sieving)

Form 2.N. Particle size distribution chart

Form 2.P. Particle size distribution (pipette sedimentation)

Form 2.Q. Particle size distribution (hydrometer sedimentation)

Moisture content

Form 2.A

Location		Job ref.			
		Borehole/Pit no.			
Soil description		Sample no.			
		Depth		m	
Test method		BS 1377-2:1990:3.2		Date	
Related test					
Specimen ref.					
Container no.					
Mass of wet soil + container (m_2)		g			
Mass of dry soil + container (m_3)		g			
Mass of container (m_1)		g			
Mass of moisture ($m_2 - m_3$)		g			
Mass of dry soil ($m_3 - m_1$)		g			
Moisture content $w = \left(\frac{m_2 - m_3}{m_3 - m_1} \right) 100$		%			
			Operator		Approved

Saturation moisture content of chalk

Form 2.B

Location	Job ref.	
	Borehole/Pit no.	
Soil description	Sample no.	
	Depth	m
Test method	BS 1377-2:1990:3.3	Date

DENSITY						
Specimen no.						
Mass of specimen (m_s)	g					
Mass of specimen + filter + wax (m_w)	g					
Mass of wax ($m_w - m_s$)	g					
Density of wax (ρ_p)	Mg/m ³					
Apparent mass of waxed specimen suspended in water	g					
Volume of specimen $(V_s) = (m_w - m_g) - \left(\frac{m_w - m_s}{\rho_p} \right)$	cm ³					
Bulk density (ρ)	Mg/m ³					

MOISTURE CONTENTS						
Container no.						
Mass of wet soil + container	g					
Mass of dry soil + container	g					
Mass of container	g					
Mass of moisture	g					
Mass of dry soil	g					
Moisture content	%					

Dry density (ρ_d)	Mg/m ³					
Saturation moisture contents (w_s)	%					
		Operator	Checked	Approved		

Liquid limit (cone penetrometer) and plastic limit

Form 2.C

Location	Job ref.	
	Borehole/Pit no.	
Soil description	Sample no.	
	Depth	m
Test method	BS 1377-2:1990:4.3/4.4*	Date

PLASTIC LIMIT	Test no.	1	2	3	4	Average
Container no.						
Mass of wet soil + container	g					
Mass of dry soil + container	g					
Mass of container	g					
Mass of moisture	g					
Mass of dry soil	g					
Moisture content	%					

LIQUID LIMIT	Test no.	1	2	3	4
Initial dial gauge reading	mm				
Final dial gauge reading	mm				
Average penetration	mm				
Container no.					
Mass of wet soil + container	g				
Mass of dry soil + container	g				
Mass of container	g				
Mass of moisture	g				
Mass of dry soil	g				
Moisture content	%				

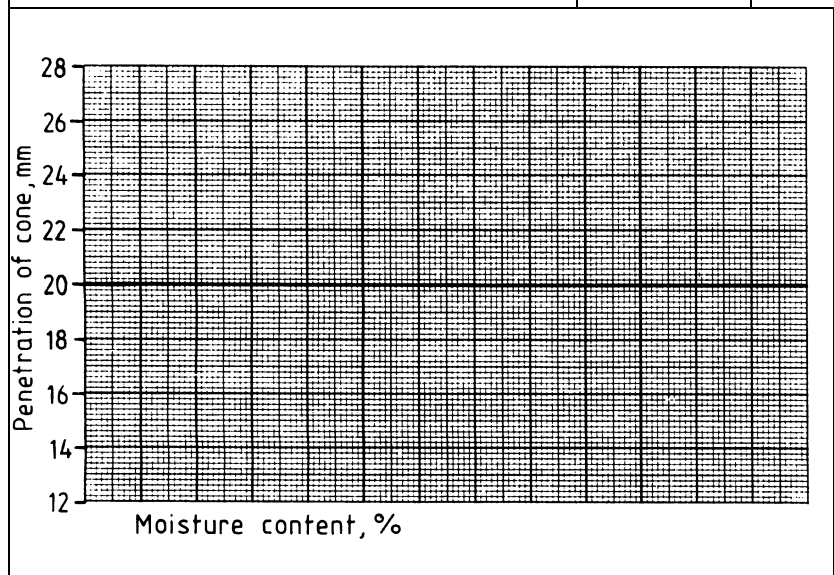

Sample preparation*

as received
washed on 425 µm sieve
air dried at°C
oven dried at°C
not known
Proportion retained
on 425 µm sieve%

Liquid limit %

Plastic limit %

Plasticity index

* Delete as appropriate

Operator	Checked	Approved

Liquid limit (Casagrande method) and plastic limit Form 2.D

Location	Job ref.	
	Borehole/Pit no.	
Soil description	Sample no.	
	Depth	m
Test method	BS 1377-2:1990:4.5/4.6*	Date

PLASTIC LIMIT	Test no.	1	2	3	4	Average
Container no.						
Mass of wet soil + container	g					
Mass of dry soil + container	g					
Mass of container	g					
Mass of moisture	g					
Mass of dry soil	g					
Moisture content	%					

LIQUID LIMIT	Test no.	1	2	3	4	5
Number of bumps						
Container no.						
Mass of wet soil + container	g					
Mass of dry soil + container	g					
Mass of container	g					
Mass of moisture	g					
Mass of dry soil	g					
Moisture content	%					

	Sample preparation* as received washed on 425 µm sieve air dried at°C oven dried at°C not known Proportion retained on 425 µm sieve%	
	Liquid limit	%
	Plastic limit	%
	Plasticity index	
	* Delete as appropriate	
	Operator	Checked

Shrinkage limit (cylindrical specimen)

Form 2.E

Location	Job ref.	
	Borehole/Pit no.	
Soil description	Sample no.	
	Depth	m
Test method	BS 1377-2:1990:6.3	Date
Method of preparation		

INITIAL CONDITIONS

Immersion tank:	Specimen	mass	g
diameter D mm	length mm	volume	cm^3
volume factor $\frac{\pi D^2}{4 \cdot 000}$	diameter mm	density	Mg/m^3

TEST DATA

Measurement no.	1	2	3	4	5	6	oven dried
Date							
Time							
Micrometer readings	zero mm						
	with sample mm						
	difference mm						
Specimen	volume cm^3						
	mass g						
	density Mg/m^3						
Volume per 100 g dry soil cm^3							
Moisture content %							0

	Proportion retained on 425 μm sieve %		
	Shrinkage ratio		
	Shrinkage limit		
	Operator	Checked	Approved

Shrinkage limit (disc specimen)

Form 2.F

Location	Job ref.	
	Borehole/Pit no.	
Soil description	Sample no.	
	Depth	m
Test method	BS 1377-2:1990:6.4	Date
Method of preparation		

TEST DATA

Specimen reference					
Shrinkage dish no.					
Mass of wet soil + dish	m_3	g			
Mass of dish	m_2	g			
Mass of wet soil	$m_1 = m_3 - m_2$	g			
Mass of dry soil + dish	m_4	g			
Mass of dry soil	$m_d = m_4 - m_2$	g			
Initial moisture content	$w_1 = \left(\frac{m_1 - m_d}{m_d} \right) 100$	%			
Volume of mercury in shrinkage dish	V_1	mL			
Volume of mercury displaced by dry soil	V_d	mL			
Volume of shrinkage	$V_1 - V_d$	mL			
Shrinkage limit	$w_s = w_1 - \left(\frac{V_1 - V_d}{m_d} \right) 100$	%			
Shrinkage ratio	$R_s = \frac{m_d}{V_d}$				
Given moisture content	w	%			
Volumetric shrinkage	$V_s = \frac{w - w_s}{R_s}$				

Shrinkage limit (disc specimen) (concluded)
DATA FOR SHRINKAGE CURVE

Form 2.F

Measurement no.	1	2	3	4	5	6
Mass of soil pat m g						
Volume of soil pat V mL						
Volume per 100 g of dry soil $U = \left(\frac{V}{m_d}\right) 100$						
Moisture content $w = \left(\frac{m - m_d}{m_d}\right) 100$ %						
			Proportion retained on 425 μ m sieve...%			
			<table border="1"> <tr> <td>Shrinkage limit</td> </tr> <tr> <td>Shrinkage ratio</td> </tr> <tr> <td>Volumetric Shrinkage</td> </tr> </table>			
Shrinkage limit						
Shrinkage ratio						
Volumetric Shrinkage						
			Operator	Checked	Approved	

Linear shrinkage

Form 2.G

Location	Job ref.	
	Borehole/Pit no.	
Soil description	Sample no.	
	Depth	m
Test method	BS 1377-2:1990:6.5	Date
Method of preparation		

TEST DATA

Specimen reference				
Percentage passing 425 μ m sieve				
Initial length L_o mm				
Oven-dried length L_D mm				
Linear shrinkage $100 \left(1 - \frac{L_D}{L_o}\right)$ %				
		Operator	Checked	Approved

Density by immersion in water

Form 2.H

Location	Job ref.	
	Borehole/Pit no.	
Soil description	Sample no.	
	Depth	m
Test method	BS 1377-2:1990:7.3	Date

Density of wax used (ρ_p) = Mg/m³

Sample reference						
Mass of soil sample (m_s)	g					
Mass of specimen after filling air voids (m_f)	g					
Mass of specimen after waxing (m_w)	g					
Mass of wax ($m_p = m_w - m_f$)	g					
Apparent mass of waxed specimen suspended in water (m_g)	g					
Volume of specimen $V_s = (m_w - m_g) - \frac{m_p}{\rho_p}$	cm ³					
Bulk density $\rho = \frac{m_s}{V_s}$	Mg/m ³					
Moisture content container no.						
Moisture content (w)	%					
Dry density $\rho_d = \frac{100 \rho}{100 + w}$	Mg/m ³					
		Operator	Checked	Approved		

Density by water displacement

Form 2.J

Location	Job ref.	
	Borehole/Pit no.	
Soil description	Sample no.	
	Depth	m
Test method	BS 1377-2:1990:7.4	Date

Density of wax used (ρ_p) = Mg/m³

Specimen reference						
Mass of soil sample (m_s)	g					
Mass of specimen after filling air voids (m_f)	g					
Mass of specimen after waxing (m_w)	g					
Mass of wax ($m_p = m_w - m_f$)	g					
Mass of receiver + displaced water (m_2)	g					
Mass of receiver empty (m_1)	g					
Volume of specimen $V_s = (m_2 - m_1) - \frac{m_p}{\rho_p}$	cm ³					
Bulk density $\rho = \frac{m_s}{V_s}$	Mg/m ³					
Moisture content container no.						
Moisture content (w)	%					
Dry density $\rho_d = \frac{100 \rho}{100 + w}$	Mg/m ³					
		Operator	Checked	Approved		

Particle density (gas jar)

Form 2.K

Location			Job ref.		
			Borehole/Pit no.		
Soil description			Sample no.		
			Depth		m
Test method			BS 1377-2:1990:8.2		Date
Method of preparation					
Specimen reference					
Mass of gas jar, plate, soil and water	m_3	g			
Mass of gas jar, plate and soil	m_2	g			
Mass of gas jar, plate and water	m_4	g			
Mass of gas jar and plate	m_1	g			
Mass of soil	$m_2 - m_1$	g			
Mass of water in full jar	$m_4 - m_1$	g			
Mass of water used	$m_3 - m_2$	g			
Volume of soil particles	$(m_4 - m_1) - (m_3 - m_2)$	mL			
Particle density $\rho_s = \frac{m_2 - m_1}{(m_4 - m_1) - (m_3 - m_2)}$		Mg/m ³			
Average value ρ_s		Mg/m ³			
			Operator		Checked
					Approved

Form 2.L

Particle density (pycnometer)

Location	Job ref.	
	Borehole/Pit no.	
Soil description	Sample no.	
	Depth	m
Test method	BS 1377-2:1990:8.3/8.4*	Date
Method of preparation		

Small/large pycnometer*

Specimen reference						
Pycnometer number						
Mass of bottle + soil + water	m_3	g				
Mass of bottle + soil	m_2	g				
Mass of bottle full of water	m_4	g				
Mass of bottle	m_1	g				
Mass of soil	$m_2 - m_1$	g				
Mass of water in full bottle	$m_4 - m_1$	g				
Mass of water used	$m_3 - m_2$	g				
Volume of soil particles $(m_4 - m_1) - (m_3 - m_2)$		mL				
Particle density $\rho_s = \frac{m_2 - m_1}{m_4 - m_1 - m_3 - m_2} \rho_L$		Mg/m ³				
Average value ρ_s		Mg/m ³				
*Delete as appropriate						
			Operator	Checked	Approved	

Particle size distribution (sieving)

Form 2.M

Location		Job ref.	
		Borehole/Pit no.	
Soil description		Sample no.	
		Depth	m
Test method BS 1377-2:1990:9.2/9.3/9.4/9.5*		Date	
Initial dry mass	m_1	g	
BS test sieve		Mass retained g	
		actual	corrected m
		Percentage retained $\left(\frac{m}{m_1}\right) 100$	Cumulative percentage passing
	75 mm		
	63 mm		
	50 mm		
	37.5 mm		
	28 mm		
	20 mm		
Passing 20 mm	m_2		
total	(check with m_1)		
riffled	m_3		
riffled and washed	m_4		
Correction factor	$\frac{m_2}{m_3}$		
	14 mm		
	10 mm		
	6.3 mm		
Passing 6.3 mm	m_5		
total	(check with m_4)		
riffled	m_6		
Correction factor	$\left(\frac{m_2}{m_3} \times \frac{m_5}{m_6}\right)$		
	5 mm		
	3.35 mm		
	2 mm		
	1.18 mm		
	600 μm		
	425 μm		
	300 μm		
	212 μm		
	150 μm		
	63 μm		
Passing 63 μm	m_F or m_E		
Total (check with m_6)		(m_1)	
*Delete as appropriate			
		Operator	Checked
			Approved

Particle size distribution chart

Form 2.N

Location	Soil description	Job ref.	Sample no.
		Borehole/Pit no.	Depth m
Test method BS 1377-2:1990:9.2/9.3/9.4/9.5*			Date

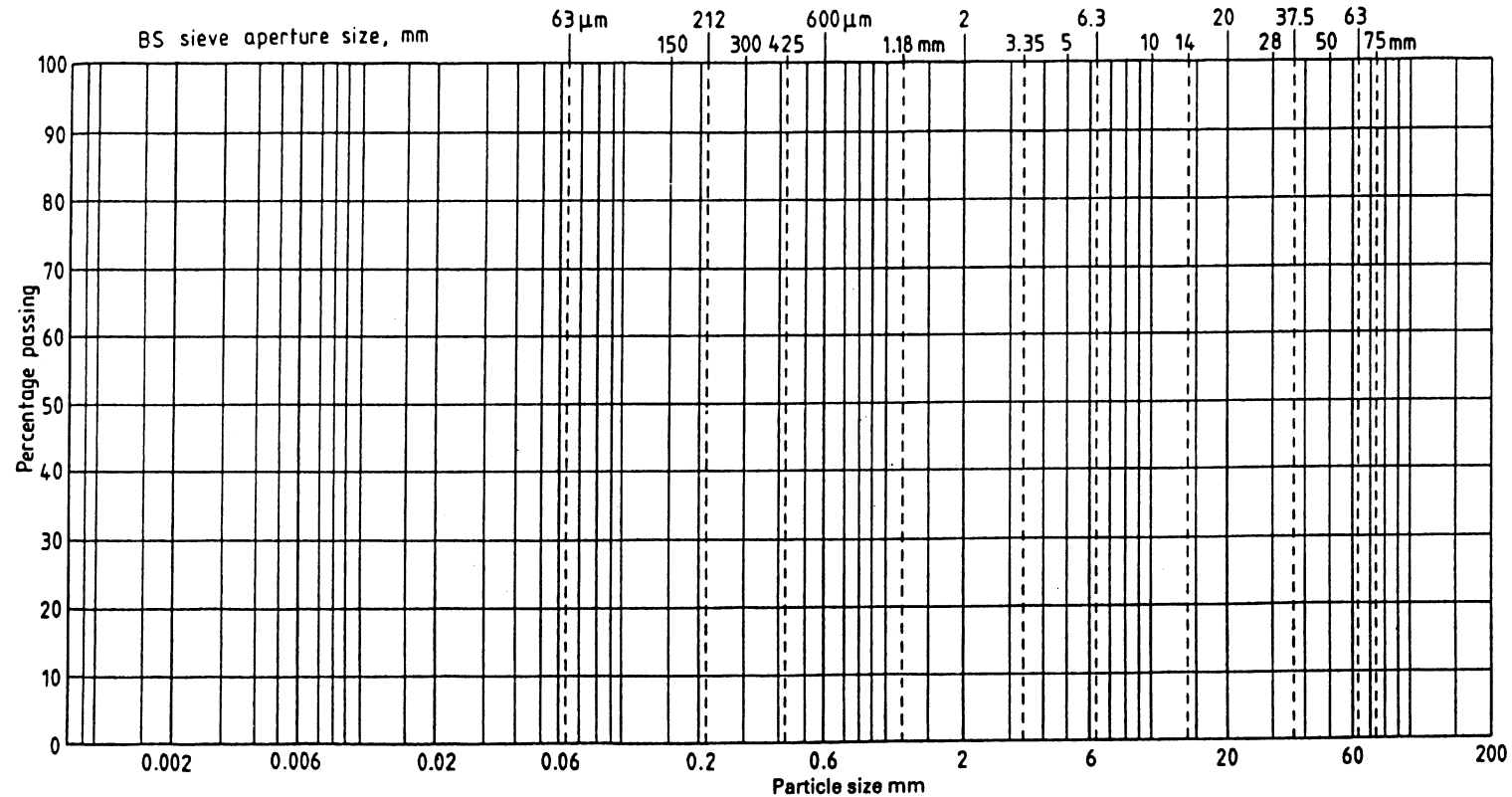

CLAY	Fine	Medium	Coarse	Fine	Medium	Coarse	Fine	Medium	Coarse	COBBLES	BOULDERS
	SILT			SAND			GRAVEL				

*Delete as appropriate	Operator	Checked	Approved

Particle size distribution (Pipette sedimentation) Form 2.P

Location	Job ref.	
	Borehole/Pit no.	
Soil description	Sample no.	
	Depth	m
Test method	BS 1377-2:1990:9.4	Date
Method of preparation		

CALIBRATION

Pipette no.	
Volume of pipette	V_p mL

SAMPLE DATA

Dry mass of soil	m	g
Particle density measured/assumed*	ρ_s	Mg/m ³

Viscosity of water at°C	η	mPa s
$D = 0.005531 \sqrt{\frac{\eta H_r}{(\rho_s - 1) t}}$		mm*

PRETREATMENT*

Pretreated with		
Initial dry mass of sample	m_o	g
Dry mass after pretreatment	m_p	g
Pretreatment loss	$m_o - m_p$	g
		%

$$K = \left(\frac{W_1 \text{ etc.} - W_r}{m} \right) 100 \%$$

$$\text{At } 25^\circ\text{C, } D = \frac{0.05221}{\sqrt{(\rho_s - 1) t}} \text{ mm}$$

TEST DATA

Pipette sample ref.						dispersant only
Date						
Time						
Elapsed time	t	min				
Temperature	T	°C				
Bottle no.						
Mass of bottle + solids		g				
Mass of bottle		g				
Mass of solids in V_p	m_1 etc.	g				m_r
Mass of solids in 500 mL	W_1 etc.	g				W_r
Mass of soil in 500 mL	$(W_1 \text{ etc.} - W_r)$	g				
Particle diameter		mm				
Percentage finer than D		%				

*Delete as appropriate

	Operator	Checked	Approved

Publications referred to

Normative reference

- BS 410, *Specification for test sieves.*
BS 718, *Specification for density hydrometers.*
BS 733, *Pyknometers.*
BS 733-1, *Specification.*
BS 903, *Methods of testing vulcanized rubber.*
BS 903-A8, *Determination of rebound resilience.*
BS 903-A26, *Determination of hardness.*
BS 1154, *Specification for natural rubber compounds.*
BS 1377, *Methods of test for soils for civil engineering purposes.*
BS 1377-1, *General requirements and sampling.*
BS 1796, *Method for test sieving.*
BS 2000, *Methods of test for petroleum and its products.*
BS 2000-49, *Penetration of bituminous materials.*
BS 5930, *Code of practice for site investigations.*

Informative reference

- Clayton, C.R.I. and Jukes, A.W. (1978). A one-point cone penetrometer liquid limit test. *Geotechnique*, 28:4:469.

British Standards Institution (BSI)

BSI is the national body responsible for preparing British Standards and other standards-related publications, information and services.

BSI is incorporated by Royal Charter. British Standards and other standardization products are published by BSI Standards Limited.

About us

We bring together business, industry, government, consumers, innovators and others to shape their combined experience and expertise into standards-based solutions.

The knowledge embodied in our standards has been carefully assembled in a dependable format and refined through our open consultation process. Organizations of all sizes and across all sectors choose standards to help them achieve their goals.

Information on standards

We can provide you with the knowledge that your organization needs to succeed. Find out more about British Standards by visiting our website at bsigroup.com/standards or contacting our Customer Services team or Knowledge Centre.

Buying standards

You can buy and download PDF versions of BSI publications, including British and adopted European and international standards, through our website at bsigroup.com/shop, where hard copies can also be purchased.

If you need international and foreign standards from other Standards Development Organizations, hard copies can be ordered from our Customer Services team.

Subscriptions

Our range of subscription services are designed to make using standards easier for you. For further information on our subscription products go to bsigroup.com/subscriptions.

With **British Standards Online (BSOL)** you'll have instant access to over 55,000 British and adopted European and international standards from your desktop. It's available 24/7 and is refreshed daily so you'll always be up to date.

You can keep in touch with standards developments and receive substantial discounts on the purchase price of standards, both in single copy and subscription format, by becoming a **BSI Subscribing Member**.

PLUS is an updating service exclusive to BSI Subscribing Members. You will automatically receive the latest hard copy of your standards when they're revised or replaced.

To find out more about becoming a BSI Subscribing Member and the benefits of membership, please visit bsigroup.com/shop.

With a **Multi-User Network Licence (MUNL)** you are able to host standards publications on your intranet. Licences can cover as few or as many users as you wish. With updates supplied as soon as they're available, you can be sure your documentation is current. For further information, email bsmusales@bsigroup.com.

BSI Group Headquarters

389 Chiswick High Road London W4 4AL UK

Revisions

Our British Standards and other publications are updated by amendment or revision.

We continually improve the quality of our products and services to benefit your business. If you find an inaccuracy or ambiguity within a British Standard or other BSI publication please inform the Knowledge Centre.

Copyright

All the data, software and documentation set out in all British Standards and other BSI publications are the property of and copyrighted by BSI, or some person or entity that owns copyright in the information used (such as the international standardization bodies) and has formally licensed such information to BSI for commercial publication and use. Except as permitted under the Copyright, Designs and Patents Act 1988 no extract may be reproduced, stored in a retrieval system or transmitted in any form or by any means – electronic, photocopying, recording or otherwise – without prior written permission from BSI. Details and advice can be obtained from the Copyright & Licensing Department.

Useful Contacts:

Customer Services

Tel: +44 845 086 9001

Email (orders): orders@bsigroup.com

Email (enquiries): cservices@bsigroup.com

Subscriptions

Tel: +44 845 086 9001

Email: subscriptions@bsigroup.com

Knowledge Centre

Tel: +44 20 8996 7004

Email: knowledgecentre@bsigroup.com

Copyright & Licensing

Tel: +44 20 8996 7070

Email: copyright@bsigroup.com