

BS 1245:2012



BSI Standards Publication

Pedestrian doorsets and door frames made from steel sheet – Specification

bsi.

...making excellence a habit.™

Publishing and copyright information

The BSI copyright notice displayed in this document indicates when the document was last issued.

© The British Standards Institution 2012

Published by BSI Standards Limited 2012

ISBN 978 0 580 56185 6

ICS 91.060.50

The following BSI references relate to the work on this standard:

Committee reference B/538/2

Draft for comment 11/30142900 DC

Publication history

First published 1945

Second edition, November 1951

Third edition, February 1975

Fourth (present) edition, June 2012

Amendments issued since publication

Date	Text affected
------	---------------

Contents

Foreword *ii*

1	Scope	1
2	Normative references	1
3	Terms and definitions	2
4	Handing	3
5	Components	3
6	Construction and design	8
7	Glazing	22
8	Ventilation devices	22
9	Installation, use, cleaning and maintenance	22
10	Security	22
11	Safety in case of fire	22
12	Safety in use	22
13	Weathertightness	23
14	Operation and strength characteristics	23
15	Hygiene, health and the environment	23
16	Acoustic performance	23
17	Energy conservation	23
18	Marking	23

Annexes

Annex A (normative)	Specification for handing	25
Annex B (informative)	Additional guidance on the construction of door leaves	28

Bibliography 32

List of figures

Figure 1	– Typical isometric lock preparation detail in door leaf	5
Figure 2	– Typical doorset configurations and hardware locations	6
Figure 3	– Typical isometric hinge preparation detail in door leaf	7
Figure 4	– Key to sizing: between reveals (second fix)	9
Figure 5	– Key to sizing: studwork or built in to brickwork (first fix)	10
Figure 6	– Typical frame assembly methods	12
Figure 7	– Typical profiles for single swing jambs and heads	13
Figure 8	– Typical profiles for double swing jambs and heads	14
Figure 9	– Typical sill details	15
Figure 10	– Typical frame fixing methods	17
Figure 11	– Typical transom assembly methods	19
Figure 12	– Typical removable steel over panel detail	20
Figure 13	– Typical glazed over panel detail	21
Figure A.1	– Specification for handing of doorsets	26
Figure B.1	– Typical steel door assembly	29
Figure B.2	– Typical section through flush double doorset	30
Figure B.3	– Plan of a typical over-rebated doorset	31

Summary of pages

This document comprises a front cover, an inside front cover, pages i to iv, pages 1 to 32, an inside back cover and a back cover.

Foreword

Publishing information

This British Standard is published by BSI Standards Limited, under licence from The British Standards Institution, and came into effect on 30 June 2012. It was prepared by Subcommittee B/538/2, *Doors*, under the authority of Technical Committee B/538, *Doors, windows, shutters, hardware and curtain walling*. A list of organizations represented on these committees can be obtained on request to their secretary.

Supersession

This British Standard supersedes BS 1245:1975, which is withdrawn.

Relationship with other publications

This British Standard is related to the following other standards.

- BS EN 14351-1 is the harmonized European product standard for windows and external pedestrian doorsets without resistance to fire and smoke leakage characteristics. It gives a list of performance characteristics and classifications of performance, but does not give guidance on determining the appropriate classification for any specific application.
- BS 6375 is the national application document in the UK, giving performance requirements and guidance for the selection of appropriate classes of performance from BS EN 14351-1.
- BS 8213-4 provides guidance on the survey and installation of replacement external pedestrian doorsets.

Information about this document

This is a full revision of the standard, and introduces the following principal changes:

- changes taking into account the publication of the harmonized European standard BS EN 14351 to remove any conflict between the standards ¹⁾;
- information on how the requirements relate to the European Construction Products Directive [1].

Presentational conventions

The provisions of this standard are presented in roman (i.e. upright) type. Its requirements are expressed in sentences in which the principal auxiliary verb is "shall".

Commentary, explanation and general informative material is presented in smaller italic type, and does not constitute a normative element.

Contractual and legal considerations

This publication does not purport to include all the necessary provisions of a contract. Users are responsible for its correct application.

Compliance with a British Standard cannot confer immunity from legal obligations.

¹⁾ At the time of publication of this edition of BS 1245, only BS EN 14351-1 has been published. Part 2 is in preparation. Part 3 (also in preparation) has been redesignated prEN 16034.

Particular attention is drawn to the Building Regulations 2010 [2], and to the corresponding Building (Scotland) Regulations 2004 [3] and Building Regulations (Northern Ireland) 2000 [4].

1 Scope

This British Standard specifies requirements for the design, fabrication and performance of pedestrian doorsets with leaves manufactured from steel skins with a minimum thickness of 1.0 mm, where all surfaces are steel and the edges are steel and mechanically fixed. It applies to doors whose leaves are infilled with materials of either recycled cardboard honeycomb or mineral wool.

It covers both complete doorsets, and door frames that could be used for doorsets with non-metallic leaves.

It applies to doors fitted into frames in a factory, to be installed vertically (within 15°) into buildings, as single or double units, in coupled assemblies when appropriate, of the following types:

- a) single leaf single-swing doors with or without side and over panels;
- b) double leaf single-swing doors with or without side and over panels;
- c) single leaf double-swing doors with or without side and over panels;
- d) double leaf double-swing doors with or without side and over panels.

It is applicable to assemblies up to the point of installation.

This British Standard does not specify requirements for fire resistance or smoke control characteristics.

2 Normative references

The following documents, in whole or in part, are normatively referenced in this document and are indispensable for its application. For dated references, only the edition cited applies. For undated references, the latest edition of the referenced document (including any amendments) applies.

BS 6100-1 (BS ISO 6707-1), *Building and civil engineering – Vocabulary – Part 1: General terms*

BS 6100-12, *Building and civil engineering – Vocabulary – Part 12: Plant, equipment and persons*

BS 6262 (all parts), *Glazing for buildings*

BS 6375 (all parts), *Performance of windows and doors*

BS 8000-7, *Workmanship on building sites – Part 7: Code of practice for glazing*

BS EN 1279 (all parts), *Glass in building – Insulating glass units*

BS EN 1670:2007, *Building hardware – Corrosion resistance – Requirements and test methods*

BS EN 1935, *Building hardware – Single-axis hinges – Requirements and test methods*

BS EN 10088-2, *Stainless steels – Technical delivery conditions for sheet/plate and strip of corrosion resisting steels for general purposes*

BS EN 10152, *Electrolytically zinc coated cold rolled steel flat products for cold forming – Technical delivery conditions*

BS EN 10346:2009, *Continuously hot-dip coated steel flat products – Technical delivery conditions*

BS EN 12519, *Windows and pedestrian doors – Terminology*

BS EN 13141-1, *Ventilation for buildings – Performance testing of components/products for residential ventilation – Part 1: Externally and internally mounted air transfer devices*

BS EN 13142, *Ventilation for buildings – Components/products for residential ventilation – Required and optional performance characteristics*

BS EN ISO 4042, *Fasteners – Electroplated coatings*

BS EN ISO 9227, *Corrosion tests in artificial atmospheres – Salt spray tests*

3 Terms and definitions

For the purposes of this British Standard, the terms and definitions given in BS 6100-1, BS 6100-12, BS EN 12519 and the following apply.

3.1 coupled assembly

two or more doorsets mechanically joined to fill an opening

NOTE This was previously known as a composite assembly.

3.2 door frame

part of a doorset surrounding a door leaf and to which the door leaf is hinged

3.3 door leaf

moving element within a doorset

3.4 doorset

complete unit, as installed, comprising door leaf, door frame, any associated side panels and/or top lights, and any operating hardware, locks and accessories

NOTE This is also known as a door assembly.

3.5 fixing

component that is used to secure separate parts of a doorset to each other, to secure an item of hardware to a door part, or to secure a completed doorset into the structure of a building

3.6 glazing gasket

plastic or synthetic rubber member used between the glazing and the frame and/or between the glazing and the glazing bead

3.7 hardware

device attached to a structural member of a doorset to facilitate opening, closing or making the product secure in the frame

3.8 sill

horizontal bottom member of a door frame

NOTE This is sometimes referred to as a threshold.

3.9 ventilation device

ventilator other than an opening light incorporated into a doorset

NOTE 1 A permanent ventilation device provides continuous ventilation. A controlled device can be closed and may be adjusted to provide ventilation.

NOTE 2 A ventilation device is referred to as an "air transfer device" in BS EN 13142 and is frequently referred to as a "trickle ventilator" in the UK.

3.10 weatherseal

resilient material designed to reduce air infiltration and water penetration

NOTE This is sometimes referred to as a weatherstrip.

3.11 work size

width and height of the doorset to be supplied, as agreed between the manufacturer and the customer, established from a designed or built structural opening

4 Handing

The handing shall be in accordance the specification provided.

Where the manufacturer is specifying the handing, the specification shall conform to Annex A.

NOTE Where the manufacturer is not specifying the handing, care should be taken to check the handing designation. See Annex A.

5 Components

5.1 Steel materials

NOTE 1 Typical external steel door leaves are 40 mm to 55 mm, and the steel skins are normally 1.0 mm or 1.2 mm. Internal door leaves can be of reduced thickness and have lighter gauge skins. Some special doors for acoustic and/or security performance can be thicker and have skins of greater thickness.

Door leaves and frames shall be fabricated from one of the following:

- mild steel sheet, electro zinc coated conforming to BS EN 10152;
- mild steel sheet, hot-dip zinc coated, conforming to BS EN 10346:2009, coating designation Z275;
- austenitic stainless steel sheet or strip conforming to BS EN 10088-2.

Where metal reinforcement is used it shall be manufactured from one of the following metals:

- a) mild steel strip, hot-dip zinc coated, conforming to BS EN 10346:2009, coating designation Z275. This type of reinforcement shall be only used in profiles or systems designed and sealed so that no exterior moisture can come into contact with the reinforcement;
- b) mild steel sections which are subsequently given a corrosion-resistant coating in order to conform to the requirements in a);
- c) austenitic stainless steel sheet or strip conforming to BS EN 10088-2.

NOTE 2 This type of reinforcement can be used in any type of profile or system.

5.2 Infill material

Door leaves shall be infilled with material from one of the following:

- recycled cardboard honeycomb of a cell size of 27 mm to 28 mm and a minimum weight of 170 gsm;
- mineral wool or other insulation slabs which require additional stiffeners to reinforce the steel skins.

5.3 Hardware and hardware reinforcements

5.3.1 Locks and latches

Locks and/or latches shall be fitted using the lock/latch manufacturer's installation instructions using a lock box reinforcement, of sufficient thickness to accommodate the hardware manufacturer's recommended machine screw fixings, fixed inside the door leaf.

NOTE 1 A typical lock preparation detail is shown in Figure 1. Other arrangements are possible.

NOTE 2 Guidance on the positioning of lock/latch and operating furniture is given in BS 8300 and Figure 2. Other arrangements are possible.

Figure 1 Typical isometric lock preparation detail in door leaf

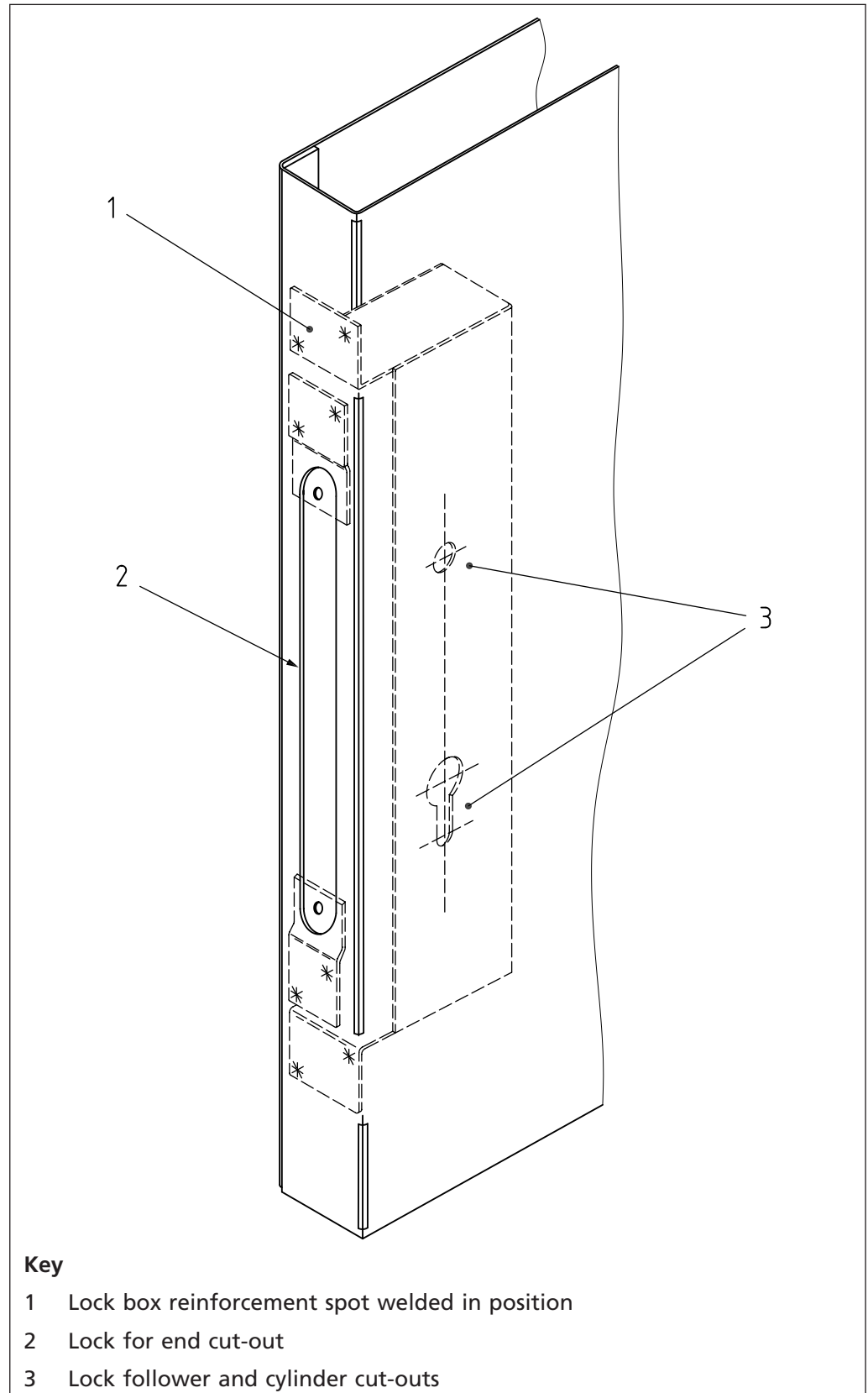
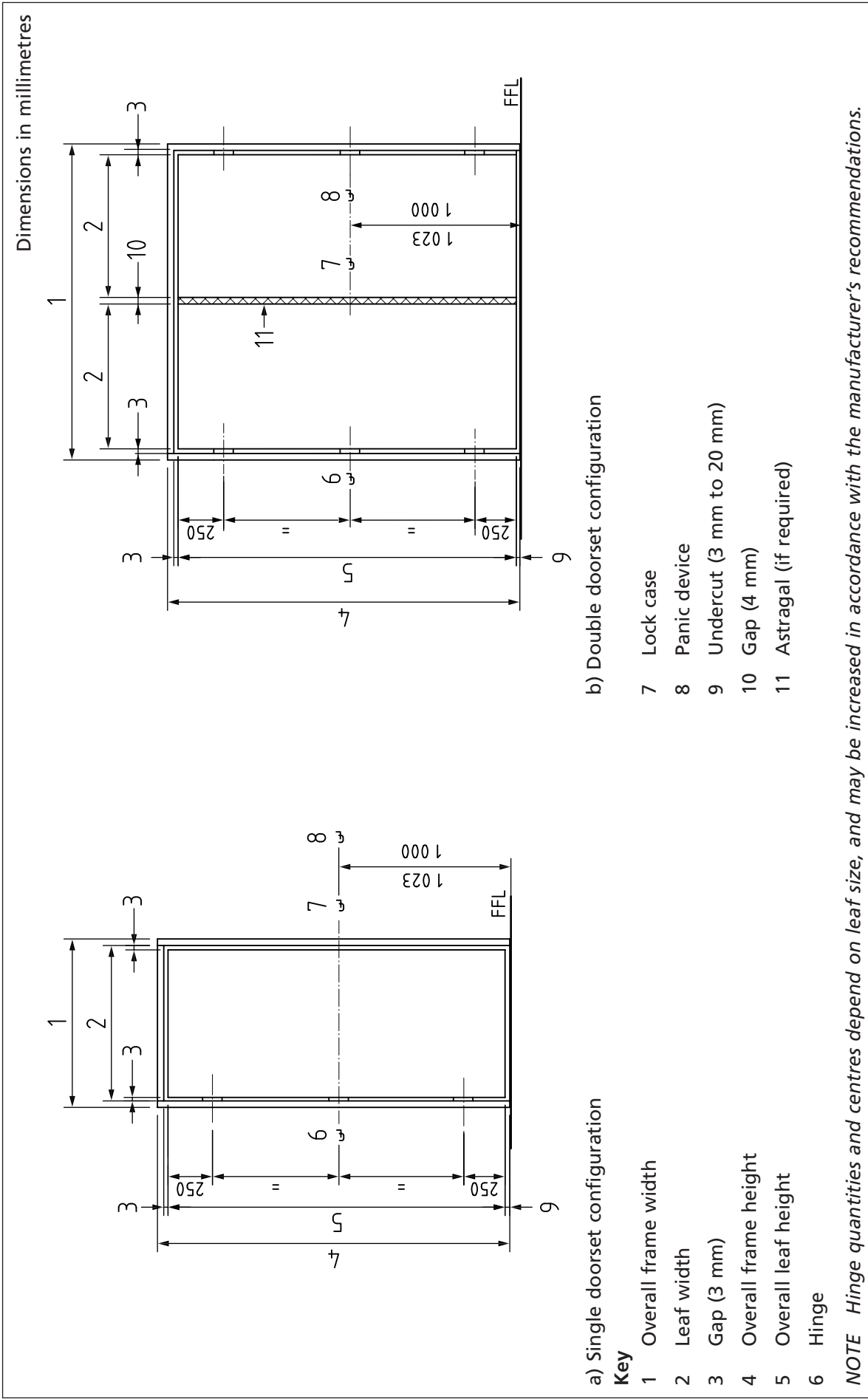

Figure 2 Typical doorset configurations and hardware locations



5.3.2 Hinges

Hinges shall conform to BS EN 1935 unless otherwise specified by the purchaser.

The hinges shall be welded or screwed to the frame at the manufacturer's discretion. Where screwed on hinges are used, there shall be a reinforcing plate fixed to the frame to which the hinge shall be screwed. The plate shall be of steel not less than 3 mm nominal thickness. The length of the plates shall be not less than 70 mm greater than the length of the hinge.

NOTE A typical hinge preparation detail is shown in Figure 3. The position of the hinges for internal and external doorsets is typically as shown in Figure 2.

Figure 3 Typical isometric hinge preparation detail in door leaf

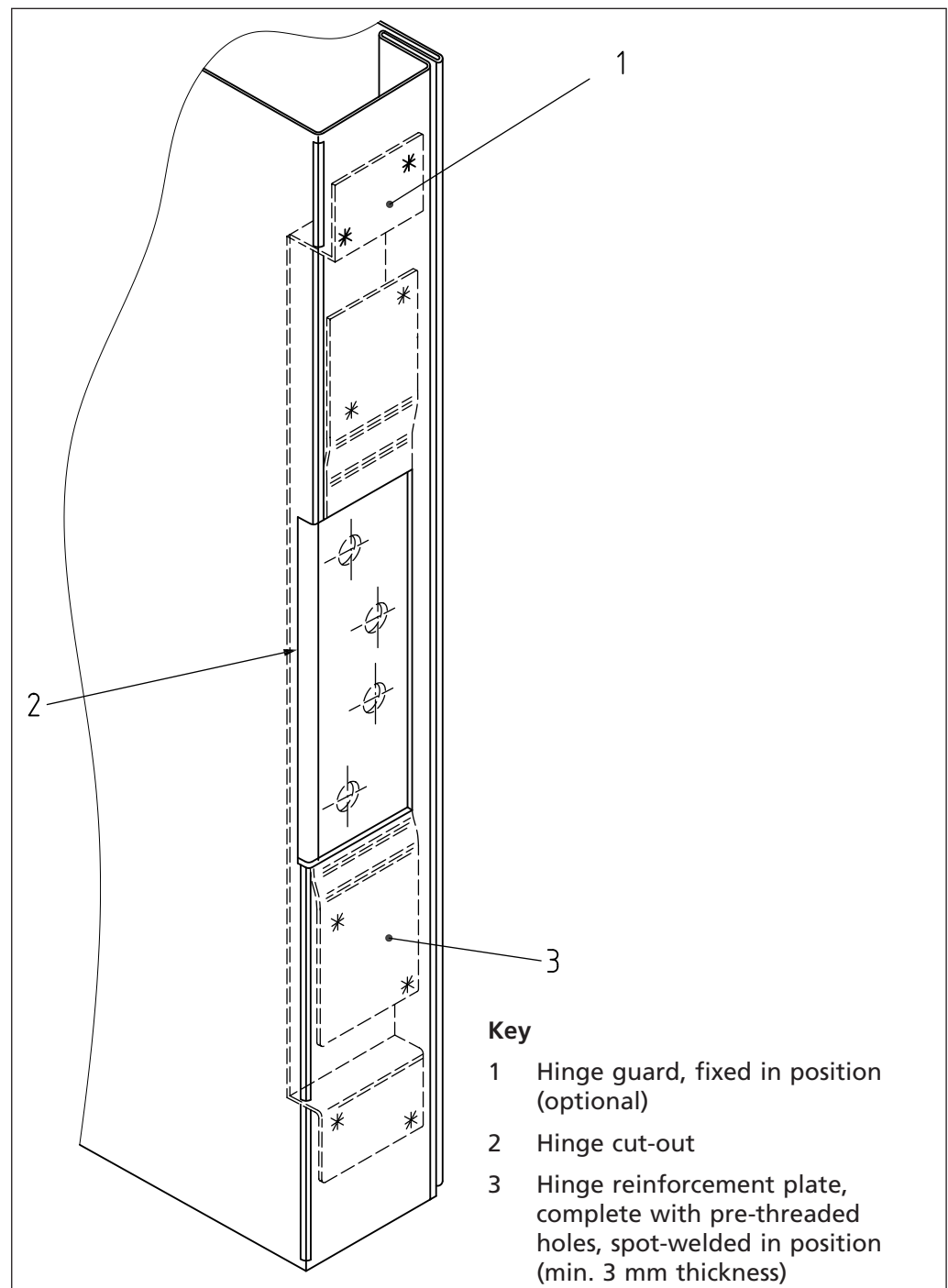

5.3.3 Finishes of hardware except for fixings

Materials for all hardware, except for fixings as defined in 3.5, shall have at least the equivalent corrosion resistance of BS EN 1670:2007, grade (class) 3 when subjected to a neutral salt spray test as specified in BS EN ISO 9227. Tests shall be carried out on complete hardware items as supplied.

NOTE 1 There is no direct correlation between a given number of hours salt spray testing and real-time natural environment exposure.

NOTE 2 In certain coastal or industrial environments, austenitic stainless steel hardware conforming to BS EN 10088-2, is particularly suitable.

Threaded components shall be treated in accordance with BS EN ISO 4042.

5.4 Glazing materials

The type, thickness and quality of glass shall be selected using the recommendations given in the relevant part of BS 6262.

Insulating glass units shall conform to BS EN 1279.

Glazing gaskets shall be suitable for the type and quality of the glass selected or specified.

5.5 Finishes

Doorsets shall be covered with a corrosion-inhibitive protective primer coating prior to delivery. For doorsets with factory-applied finishing systems, if a primer is used, it shall be applied before the final coating.

NOTE 1 Doorsets that are to be installed in corrosive atmospheres or marine environments might require additional protection.

Both the primer (where used) and the final coating shall be applied in accordance with the manufacturer's recommendations.

NOTE 2 The finish needs to be durable. A single coat will give a cover of 30 μm to 40 μm . When a primer is added under the top coat then 60 μm would be the minimum thickness. If necessary the coating specification should be agreed between the manufacturer and the customer prior to supply.

6 Construction and design

NOTE Additional guidance on the construction of door leaves is given in Annex B.

6.1 Sizing

The opening sizes shall be as shown in Figure 4 and Figure 5. Where both sizes are quoted the width shall be given before the height.

NOTE Attention is drawn to Approved Documents B [5] and M [6] of the Building Regulations 2000 [2] in respect of effective clear opening widths.

Figure 4 Key to sizing: between reveals (second fix)

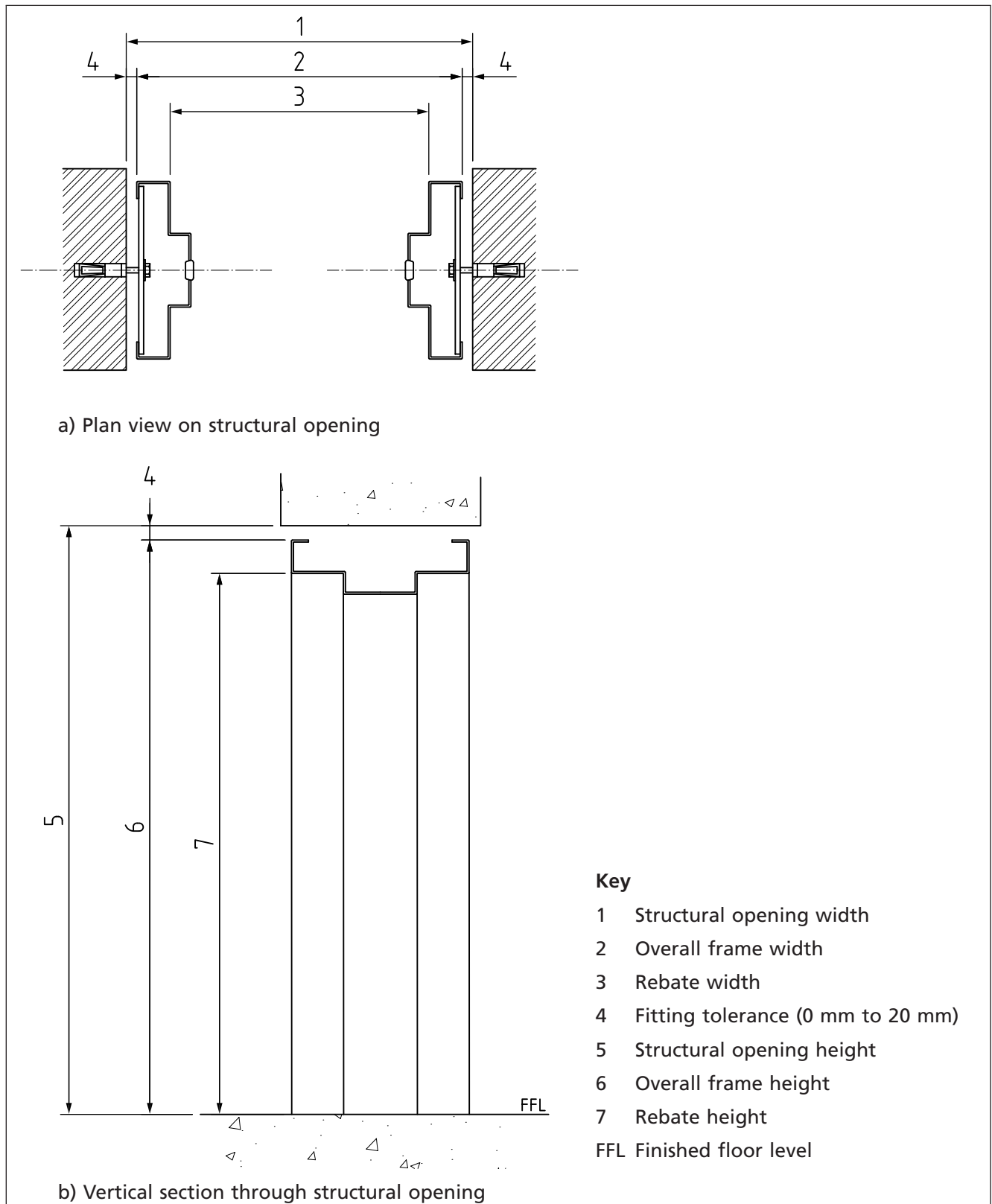
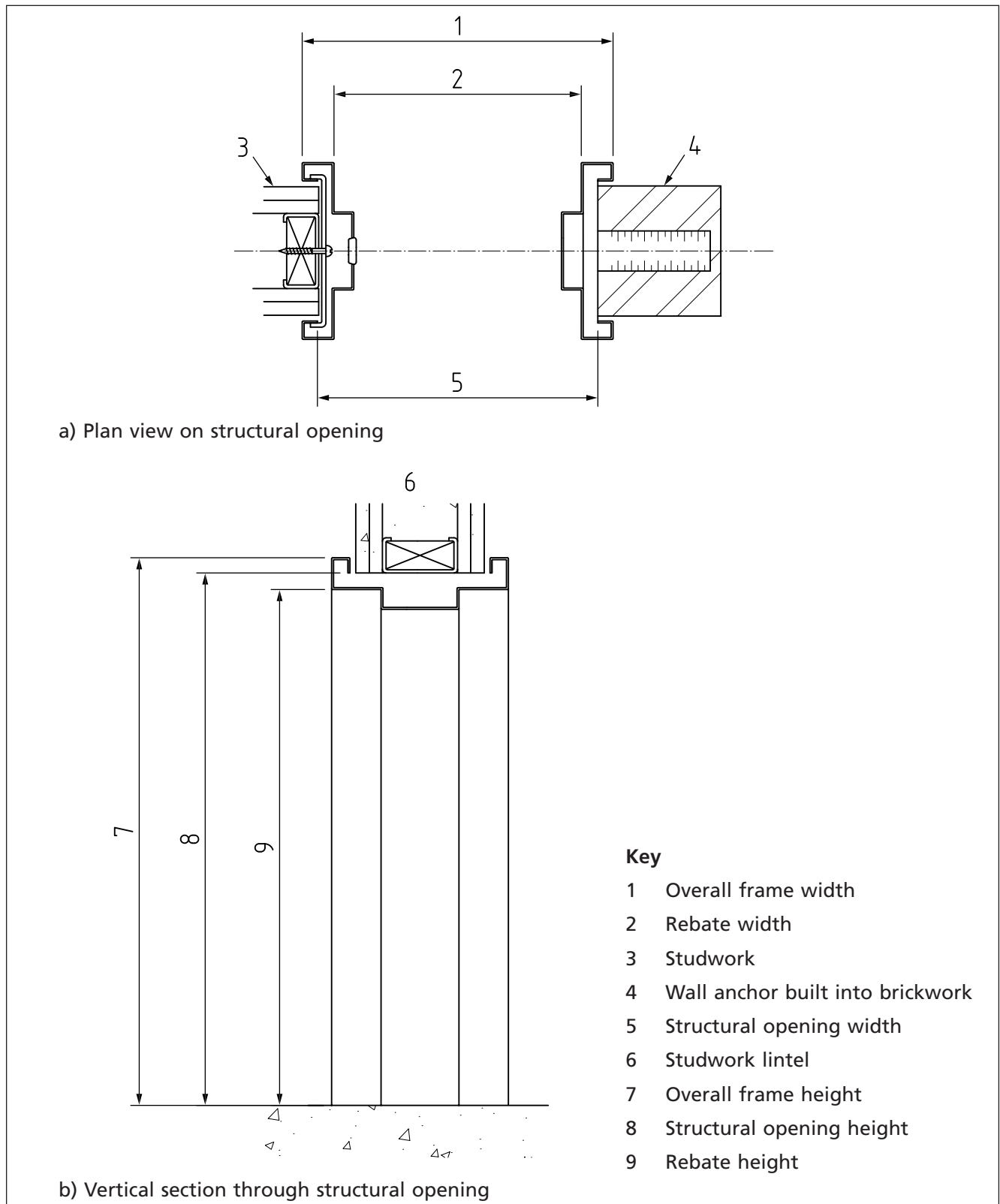

Figure 5 Key to sizing: studwork or built in to brickwork (first fix)



6.2 Manufacturing tolerances

The overall width and height of the doorset shall be the work size minus manufacturer's clearance, to allow fitting into an as-built structural opening (3.11).

6.3 Door frame construction

COMMENTARY ON 6.3

The frames for steel doorsets or for doorsets with non-metallic leaves are normally profiled from 1.2 mm or 1.5 mm thick steel sheet in various shapes and sizes. Each frame consists of two jambs and head member and, when applicable, a transom and/or sill. The whole is then rigidly joined together either by mechanical means or welding.

Steel doorset manufacturers use different methods of assembling door frames. These can be by mechanical means or welding. A number of typical assembly methods are shown in Figure 6.

Typical single and double rebate profile frames are shown in Figure 7. A typical double swing pivot jamb profile and the strike and head profiles are shown in Figure 8.

Where a transom is fitted the rebate of the transom shall fit flush with the rebate of the door frame.

Reinforcements shall be welded or mechanically fixed to the frame to receive hinges and/or lock strike plates.

When required, door frames shall be fitted with a sill, which shall be fixed flush to the base of the frame to suit the door frame profile.

NOTE Typical sill details are shown in Figure 9.

When frames are to be installed in wet construction, mortar guards shall be fixed in the frame at locations provided for lock/latch strike plates, hinges or bolts.

Frame silencers shall be fitted to the stop of the frame to cushion the closing of the door leaf unless weatherstrips or smoke seals are fitted.

Figure 6 Typical frame assembly methods

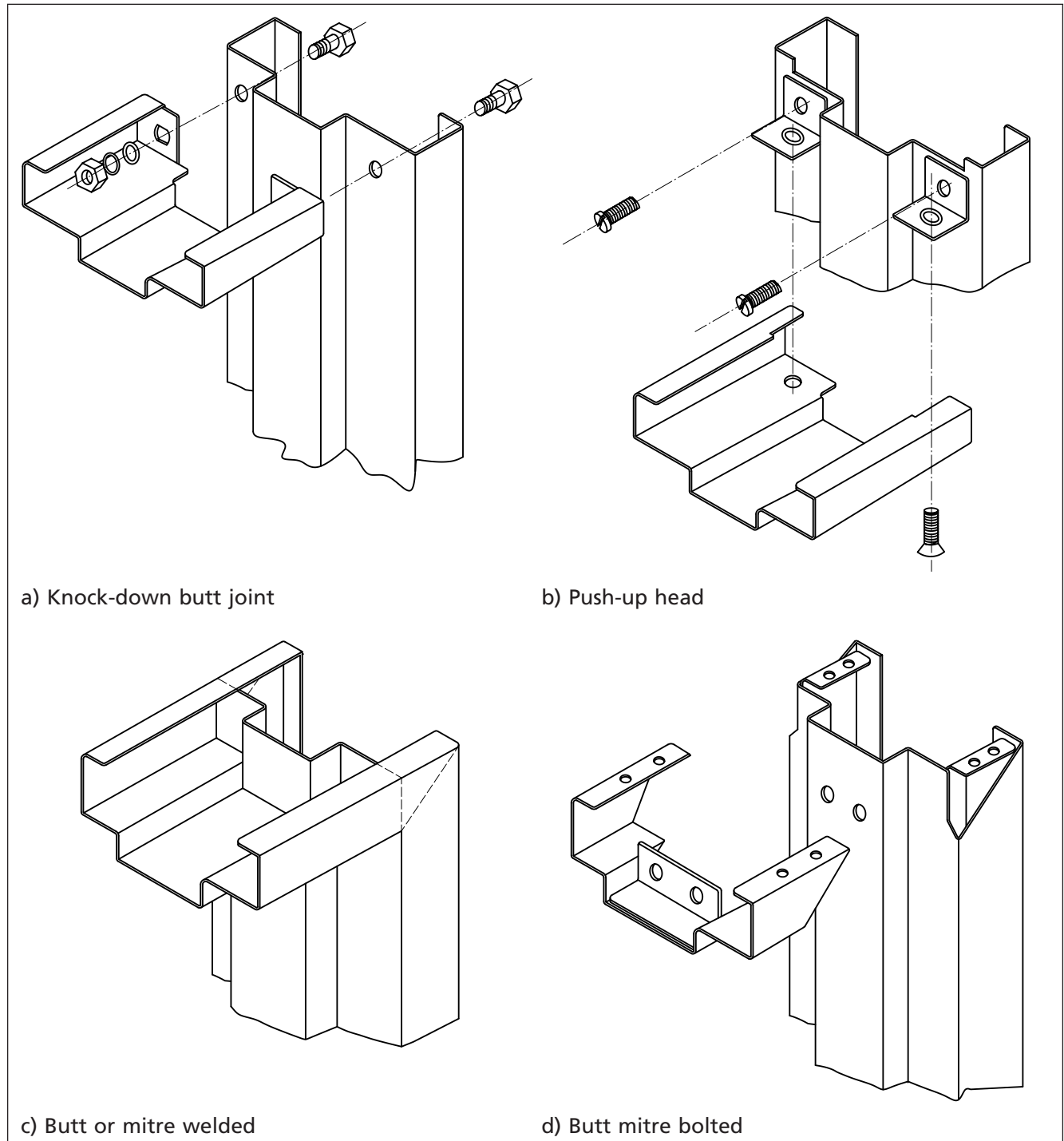

Figure 7 Typical profiles for single swing jambs and heads

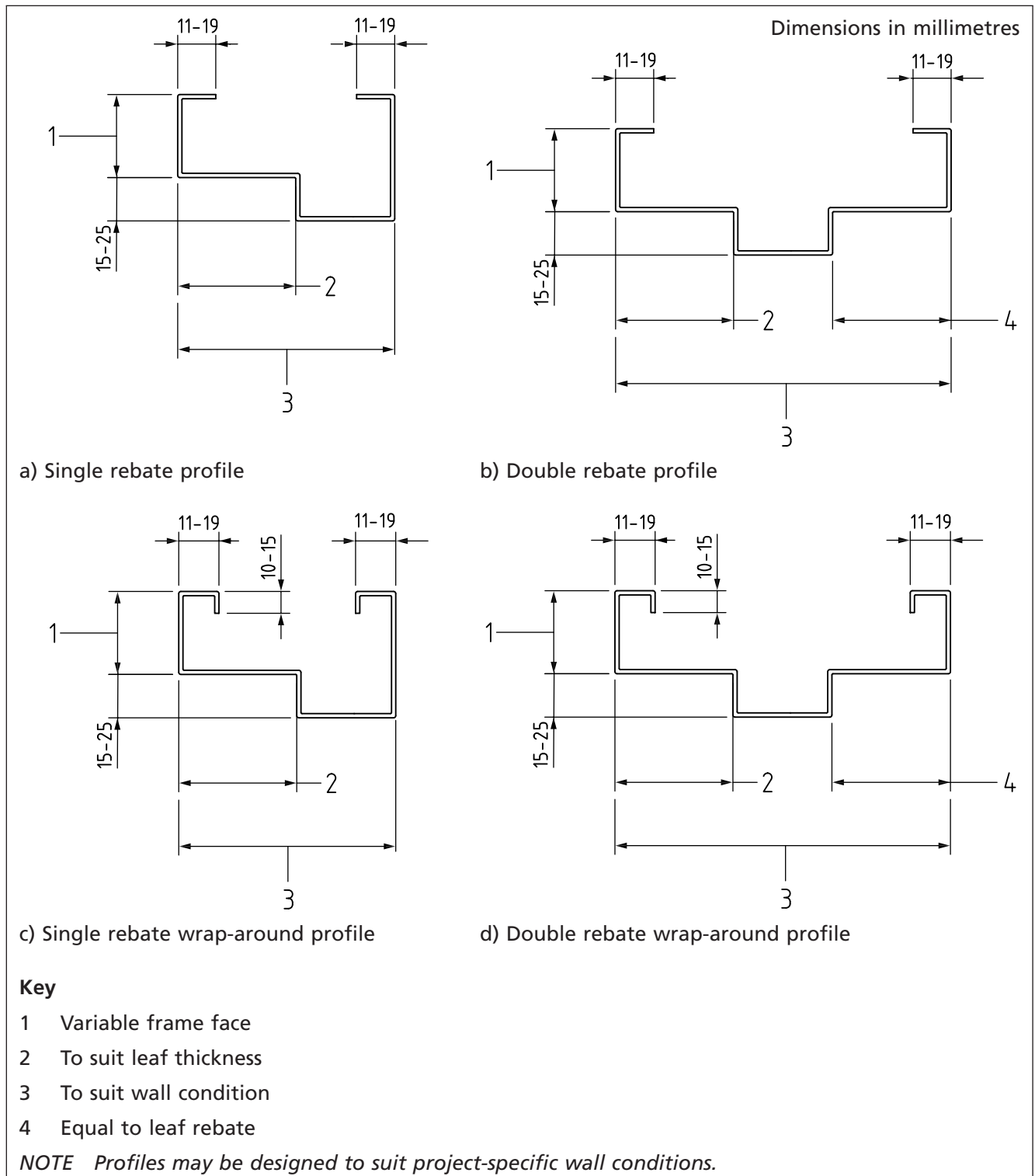

Figure 8 Typical profiles for double swing jambs and heads

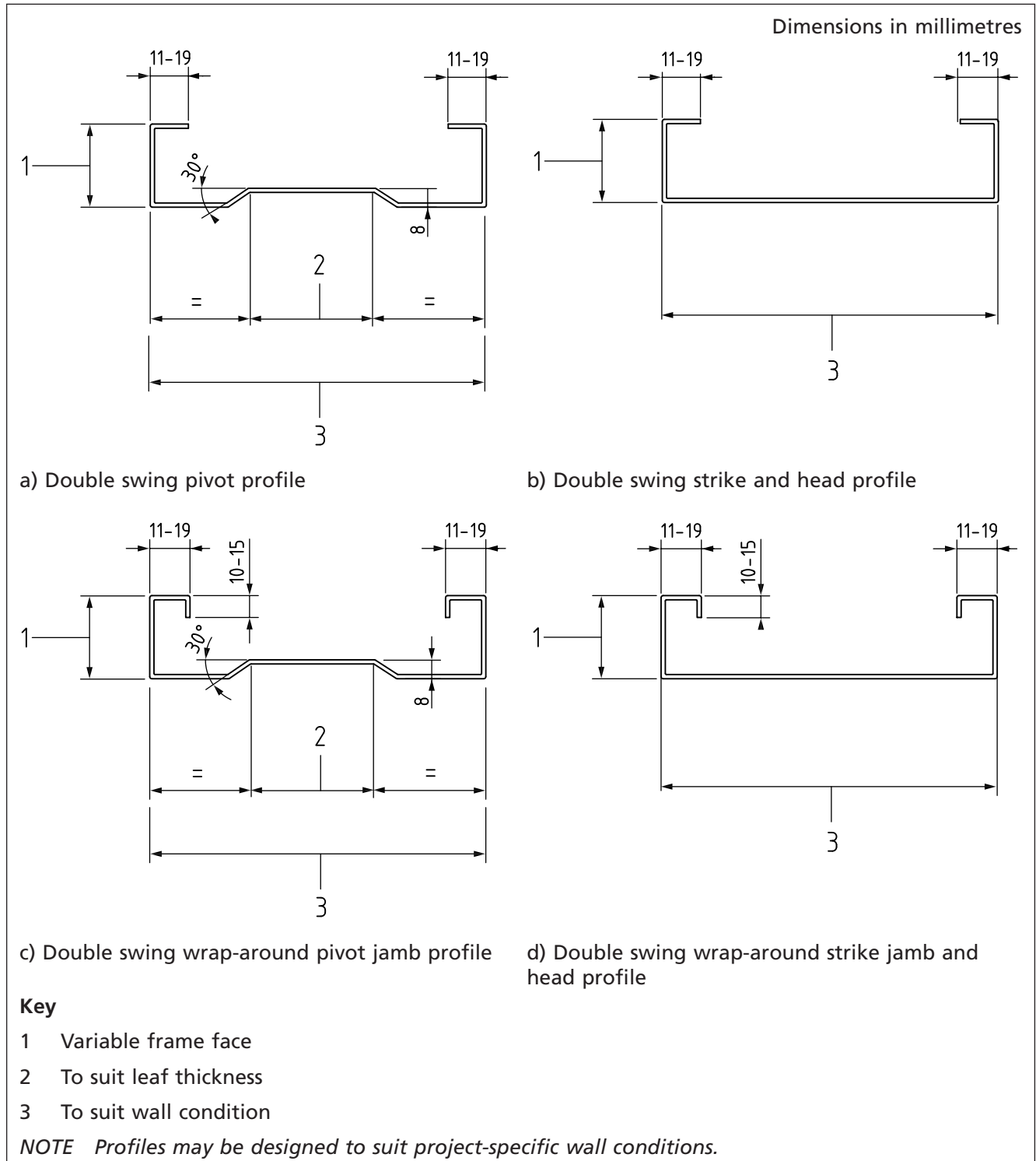
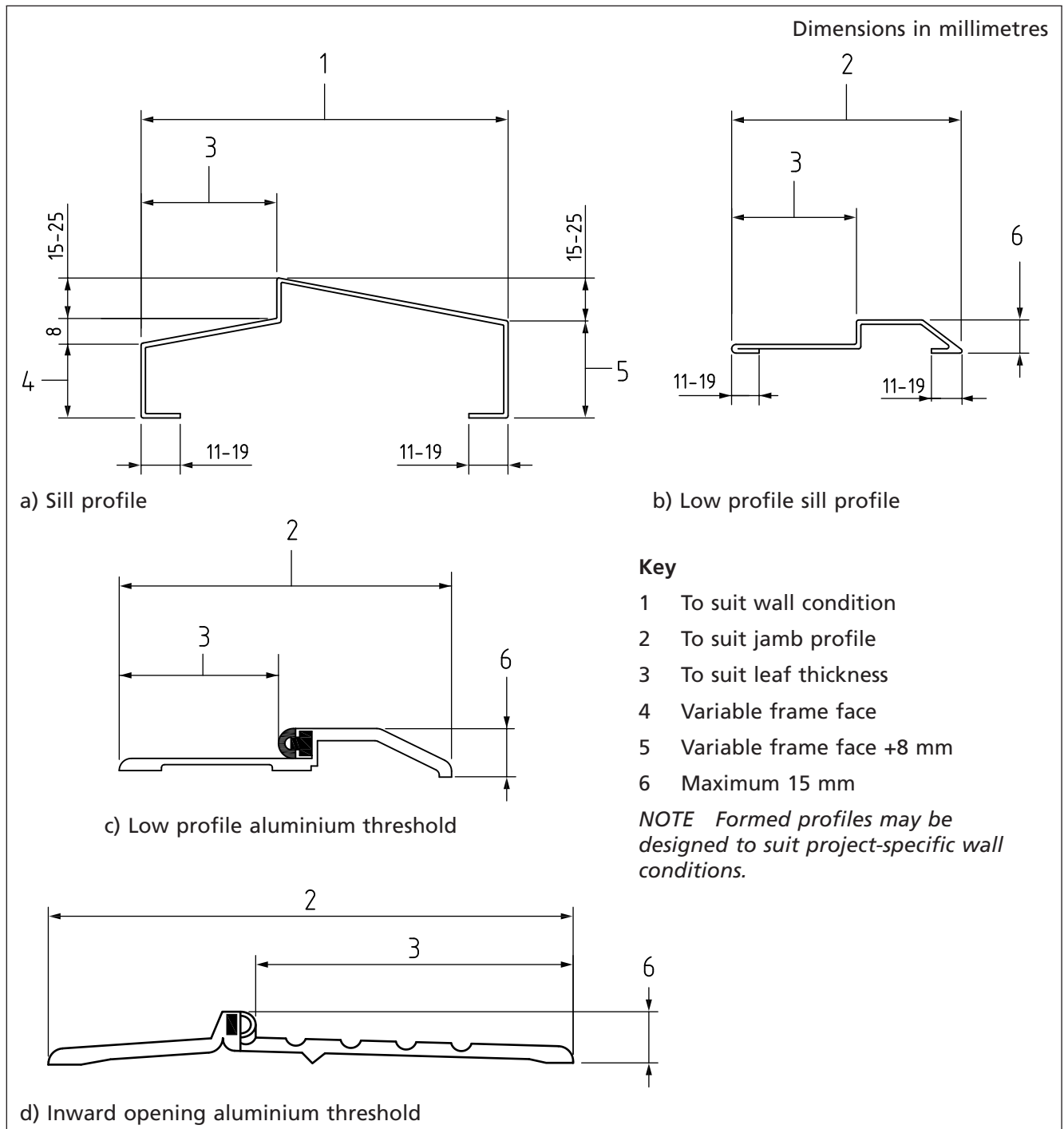

Figure 9 Typical sill details



6.4 Frame fixing methods

COMMENTARY ON 6.4

The way in which steel doorsets are fixed to openings depends on the opening construction which can be masonry, partitioning or cladded steelwork. When steel doorsets are fitted to cladding it is critical that the supporting steel structure is capable of providing a solid and rigid base to prevent movement of the door frame when the door is being used. It is recommended that the thickness of the supporting steelwork should be at least 3 mm. It is also important that where applicable the effect of thermal bridging is taken into account in the design of the interface between the door frame and the wall.

The frame fixings shall be provided by the doorset manufacturer and shall be appropriate for the type of fixing method required (see Note 1).

NOTE 1 When the door is set in position and the opening built around it, it is known as "first fix". Where the opening is already constructed and the doorset fitted afterwards it is known as "second fix". The type of fixing to use with the appropriate profile frame then requires fixings suitable for the structure.

NOTE 2 Typical frame fixing methods are shown in Figure 10.

Figure 10 Typical frame fixing methods (1 of 2)

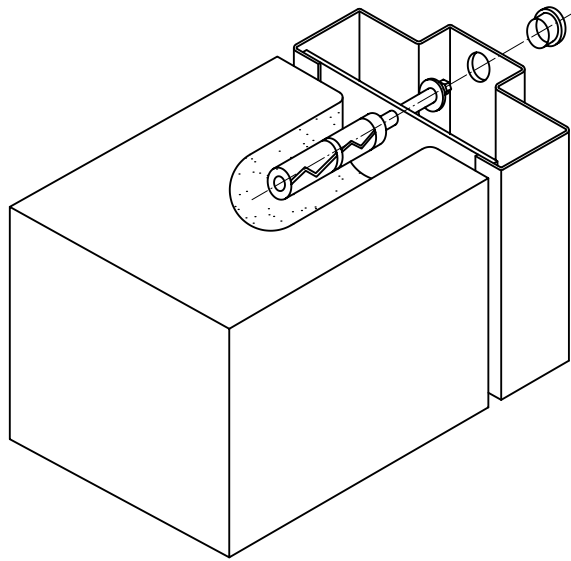

NOTE Packing shims removed for clarity.
a) Expansion bolt complete with plug

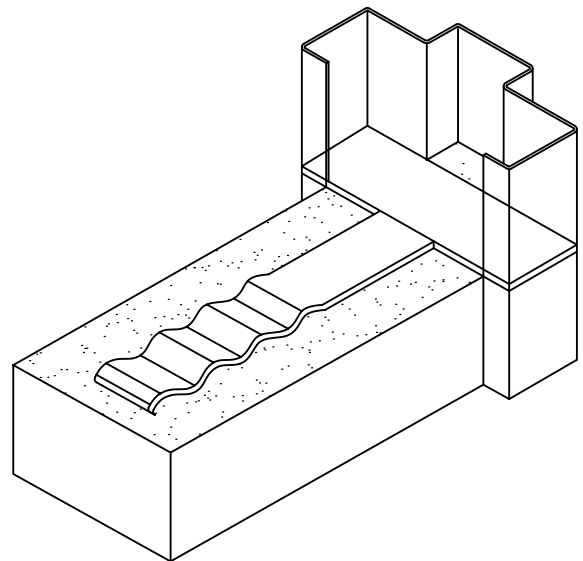

b) "T" wall anchor (first fix)

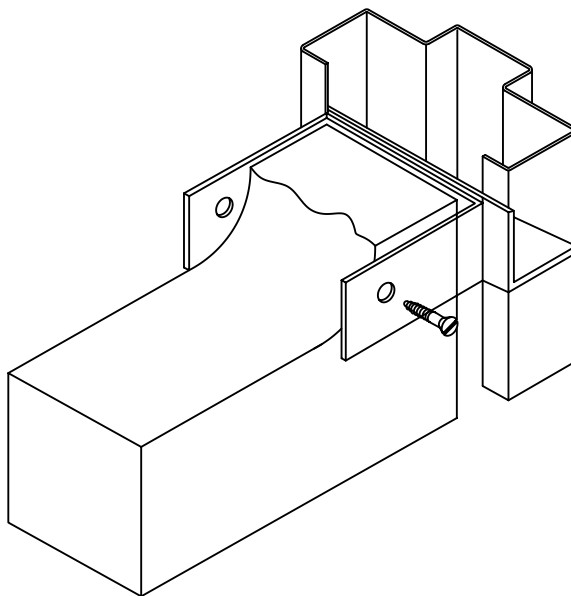

c) Wrap-around anchor

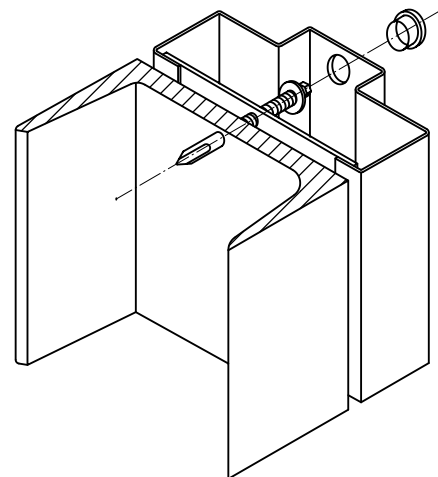

NOTE Packing shims removed for clarity.
d) Self-drilling/self-tapping screw into steelwork complete with plug

Figure 10 Typical frame fixing methods (2 of 2)

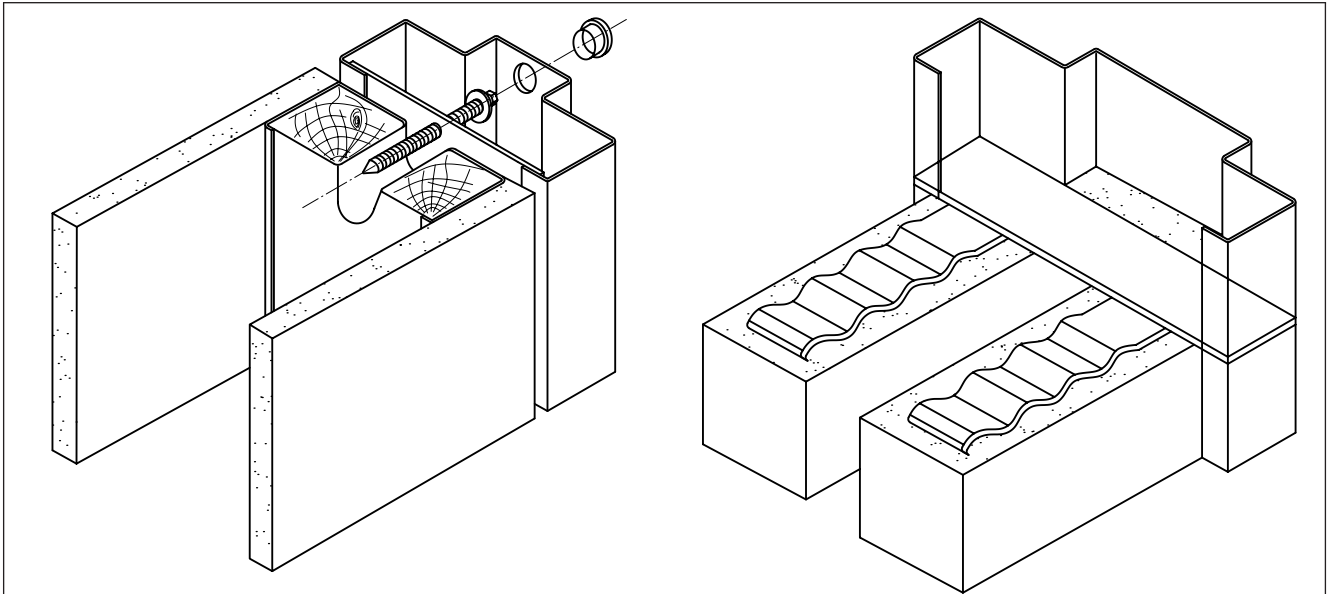

NOTE Packing shims removed for clarity.

e) Woodscrew complete with plug into studwork

f) Cavity "T" wall anchor (first fix)

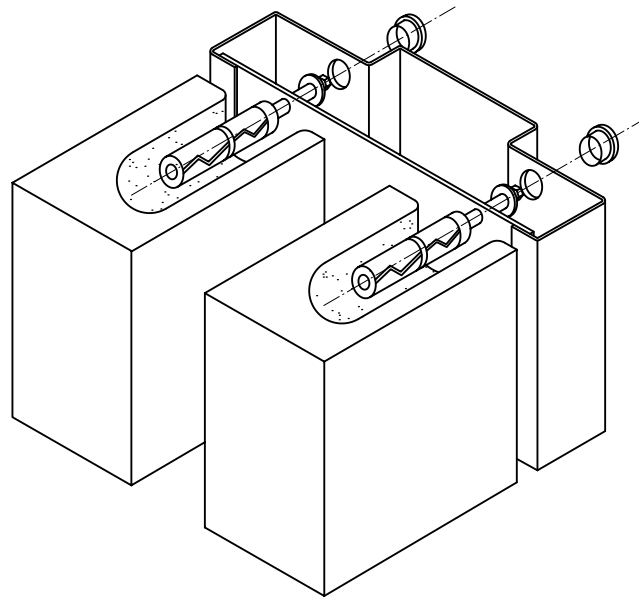

NOTE Packing shims removed for clarity.

g) Expansion bolts complete with plugs to bridge cavity in wall

6.5 Over panels and side panels

NOTE Over panels in ceiling height frames may be solid, with or without a transom bar, glazed or with ventilation devices. A typical transom fixing detail is shown in Figure 11. The method of fixing will vary from manufacturer to manufacturer when the panels are permanently fixed but sometimes the panels are removable, in which case a typical detail is shown in Figure 12. A typical detail of fixing a glazed over panel is shown in Figure 13.

The method of construction of any top and/or side panels shall be the same as that used for the door leaf.

Where infillings other than glazing are used, they shall be constructed in the same way as the door leaf.

Figure 11 Typical transom assembly methods

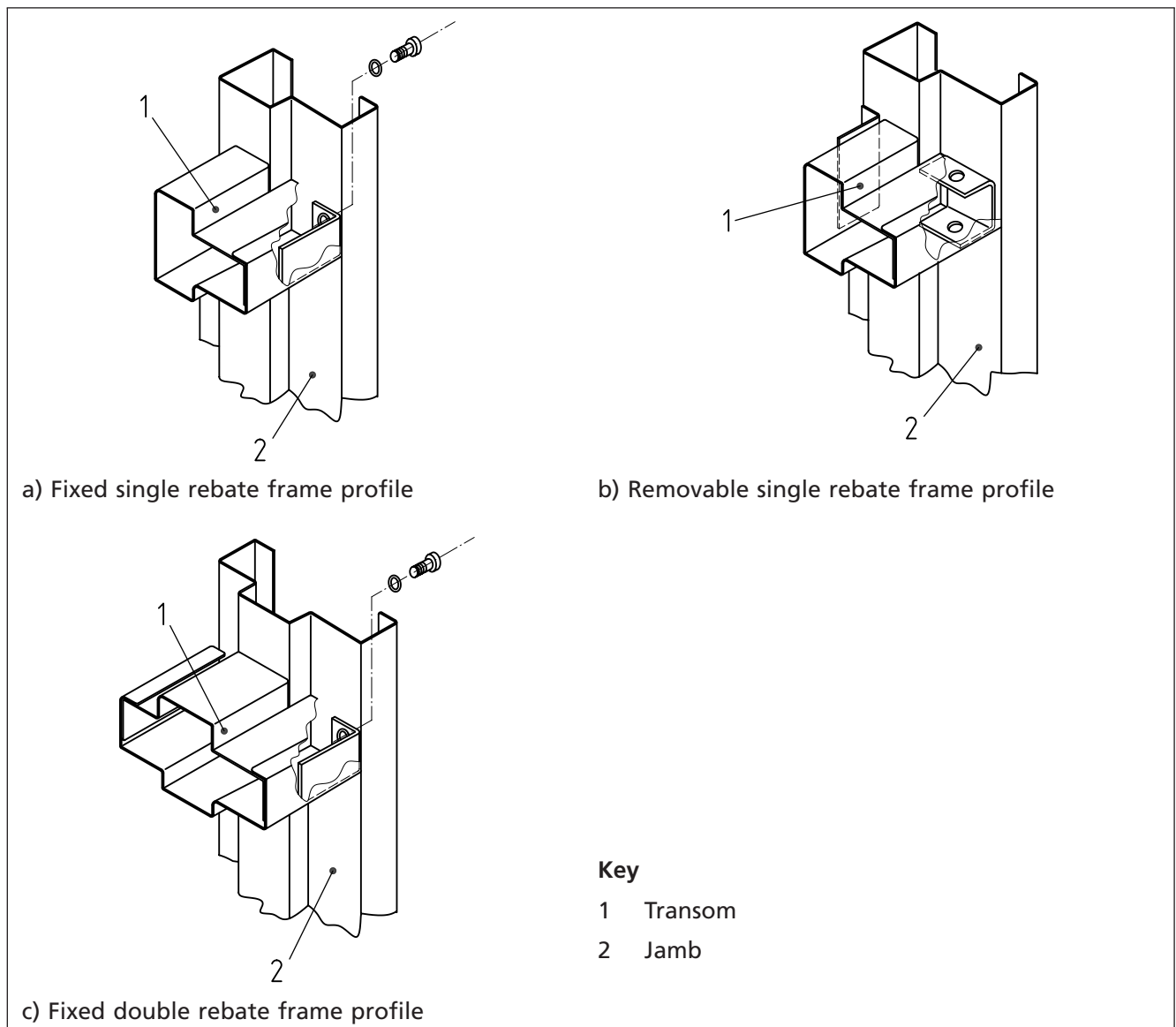
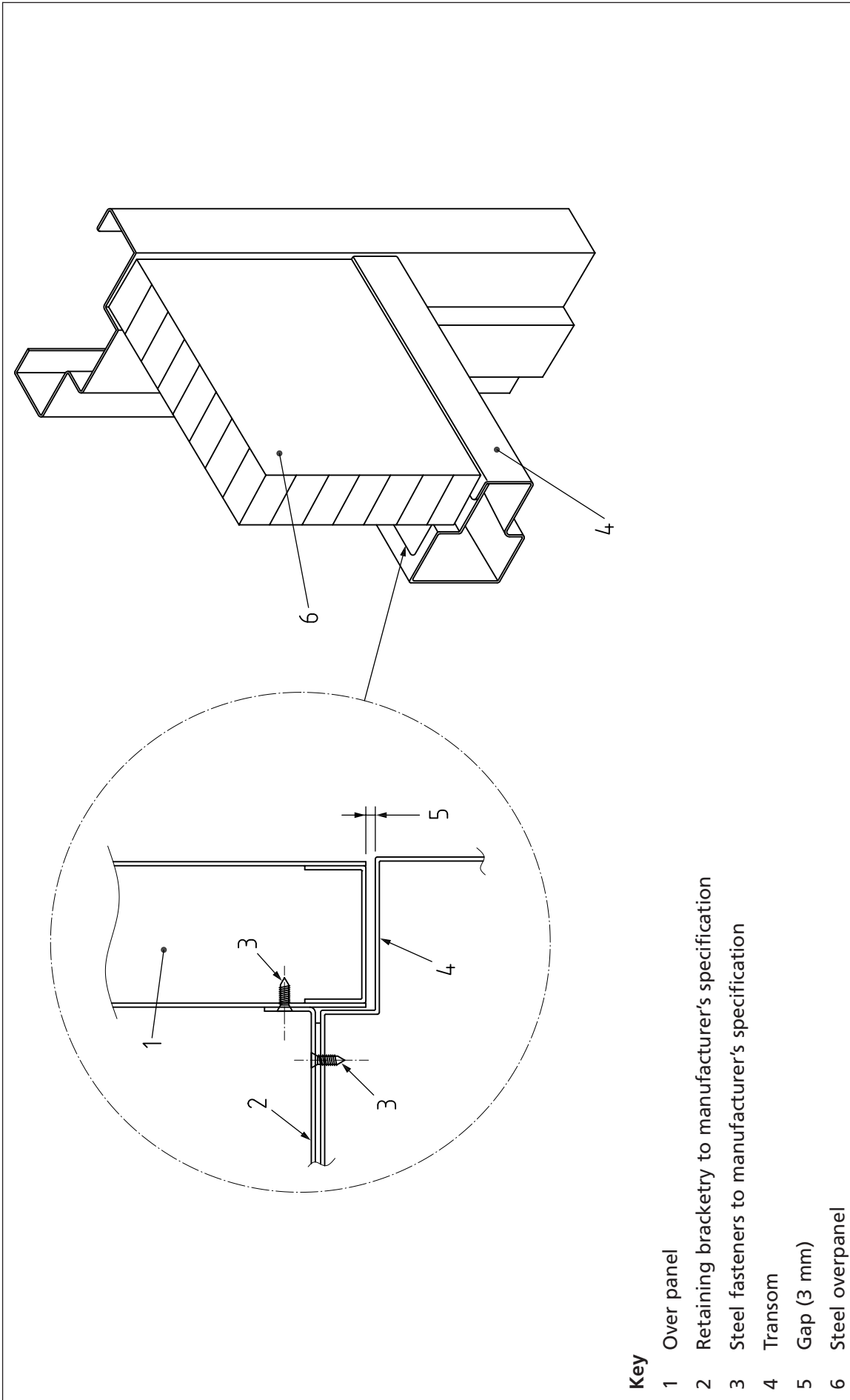

Figure 12 Typical removable steel over panel detail



Key

- 1 Over panel
- 2 Retaining bracketry to manufacturer's specification
- 3 Steel fasteners to manufacturer's specification
- 4 Transom
- 5 Gap (3 mm)
- 6 Steel overpanel

Figure 13 Typical glazed over panel detail

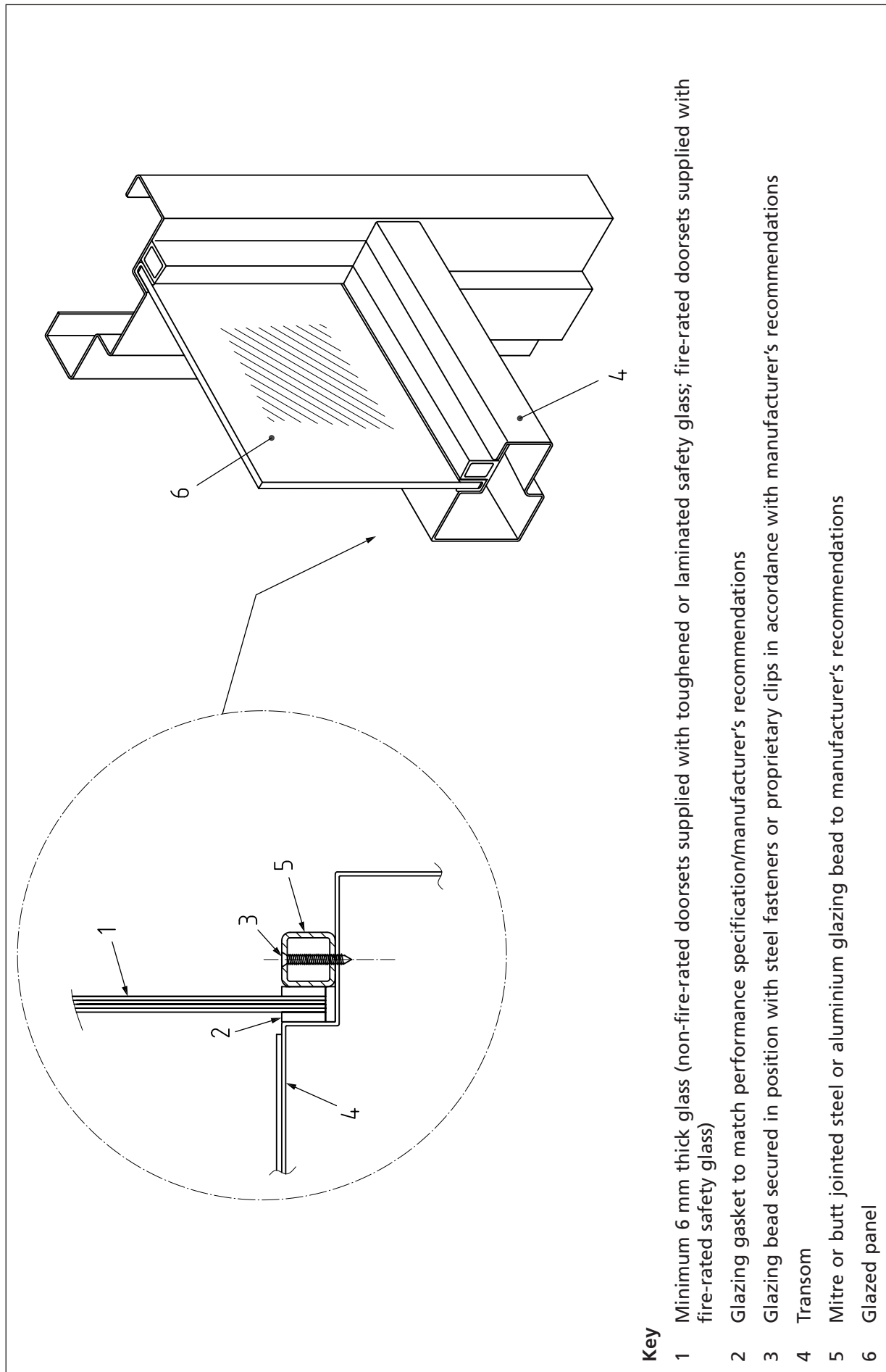

7 Glazing

Any glazing shall be in accordance with the recommendations given in the relevant part of BS 6262 and BS 8000-7. Doorsets shall also be designed to allow re-glazing without removing the outer frame from the structure of the building.

NOTE Attention is drawn to the glazing safety recommendations of BS 6262-4, particularly the requirements for marking the glass.

8 Ventilation devices

Ventilation devices shall not permit the penetration of moisture into any profile chambers that are not designed to have moisture in them.

NOTE Conformity to this requirement is determined by visual examination.

9 Installation, use, cleaning and maintenance

Guidance on the installation, use, cleaning and maintenance of doorsets shall be provided by the door manufacturer. Where appropriate, this shall include guidance on suitable types of finishing paint for doorsets that are to be finished on site.

10 Security

10.1 Basic security

Where basic security forms part of the requirements, when a completed doorset is subjected to the basic security test specified in BS 6375-3, it shall not be possible to gain entry.

10.2 Enhanced security

When enhanced security forms part of the requirements, doorsets shall conform to BS 6375-3.

11 Safety in case of fire

11.1 Fire resistance

Where fire resistance forms part of the requirements, it shall be declared in accordance with BS 6375-3.

11.2 Reaction to fire

Where reaction to fire forms part of the requirements, it shall be declared in accordance with BS 6375-3.

12 Safety in use

12.1 Impact resistance

Where impact resistance forms part of the requirements, it shall be declared in accordance with BS 6375-2.

12.2 Safety devices

Any safety devices shall conform to the requirements specified in BS 6375-2.

12.3 Emergency exit and panic devices

Any emergency exit devices or panic exit devices shall conform to the requirements in specified in BS 6375-3.

13 Weathertightness

Where weathertightness forms part of the requirements for external doorsets, the completed doorset shall meet the weathertightness requirements for the appropriate classification specified in BS 6375-1, when tested in accordance with BS 6375-1.

14 Operation and strength characteristics

Operation and strength characteristics shall be declared in accordance with BS 6375-2.

15 Hygiene, health and the environment

NOTE 1 This clause is relevant to Essential Requirement 3 of the Construction Products Directive [1].

NOTE 2 There is a requirement in BS EN 14351-1 for the manufacturer to declare if there is a risk of any potentially dangerous substances being released from the doorset during normal intended use.

The performance of any ventilation device (3.9) mounted within the doorset shall be classified in accordance with BS EN 13142 when tested in accordance with BS EN 13141-1.

16 Acoustic performance

When specified, acoustic performance shall be declared in accordance with BS 6375-3.

17 Energy conservation

Where thermal resistance forms part of the requirements for energy conservation, the U value of the doorset shall be declared in accordance with BS 6375-3.

18 Marking

Each doorset shall be identified with the following information:

- a) the number and date of this British Standard, i.e. BS 1245:2012 ²⁾;
- b) claimed performance classifications;
- c) the name or trademark of the manufacturer or other means of identifying the manufacturer; and

²⁾ Marking BS 1245:2012 on or in relation to a product represents a manufacturer's declaration of conformity, i.e. a claim by or on behalf of the manufacturer that the product meets the requirements of the standard. The accuracy of the claim is therefore solely the responsibility of the person making the claim. Such a declaration is not to be confused with third party certification of conformity, which might also be desirable.

d) means of traceability.

The identification shall be affixed:

- to any suitable part of the product; or
- on an attached label; or
- on its packaging; or
- on the accompanying commercial documents; or
- on the manufacturer's website; or
- in the manufacturer's published technical specifications.

Annex A
(normative)
A.1

Specification for handing

View

When specifying handing, the door shall be viewed from the pull side.

NOTE 1 Drawing conventions for door types are illustrated in Figure A.1. The European designations (BS EN 12519) are significantly different and care should be taken to establish which is being used.

NOTE 2 Figure 1 uses the following general conventions.

- a) Doorsets are always handed from the pull to open (hinge) side of the doorset.
- b) The outside is always treated as the more secure side of the doorset, irrespective of whether internal or external.
- c) Unless advised otherwise:
 - the key side of cylinders is fitted to the outside;
 - pull handles are fitted to the pull side;
 - door closers are fitted to the inside;
 - the secure side of vision panels and louvers is outside.

A.2 Side-hung doorsets

The handing of side-hung pedestrian doorsets shall be described by the hinge position when viewed from the pull side.

NOTE 1 For instance, a door viewed from the outside with the hinges on the left, is a left-hand door.

NOTE 2 Care should be taken to avoid confusion with door handing specified in accordance with BS EN 12519, which is determined by hinge position but viewed from the opening face which might be outside or inside.

A.3 Vertically pivoted doorsets

For doorsets pivoted vertically off-centre, the handing shall be described by the pivot position in relation to the portion opening out. The portion opening outwards shall be stated.

Figure A.1 Specification for handing of doorsets (1 of 2)

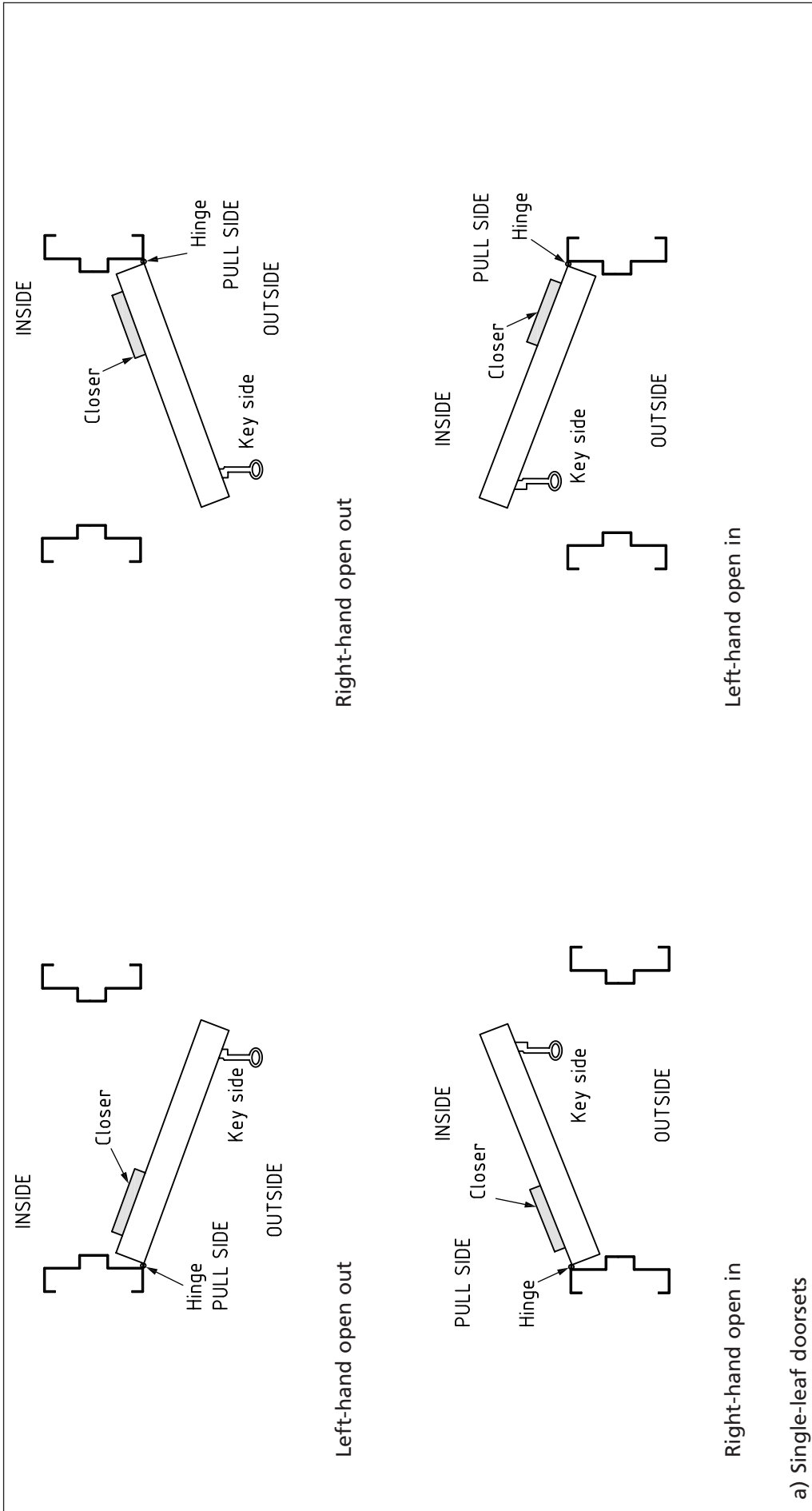

a) Single-leaf doorsets

Figure A.1 Specification for handing of doorsets (2 of 2)

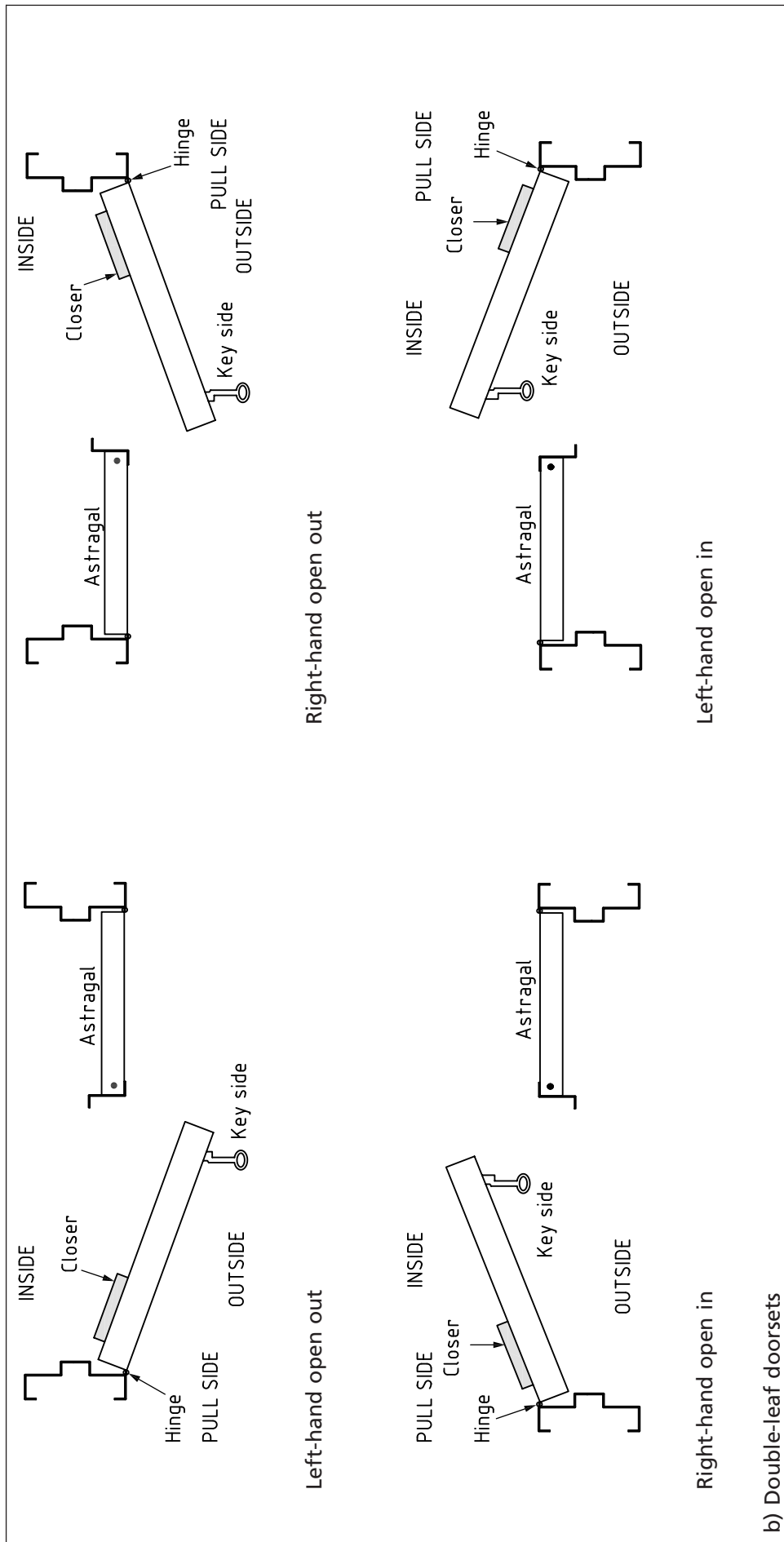

Annex B
(informative)

Additional guidance on the construction of door leaves

B.1 General

Steel doors, often referred to as metal doors, are normally supplied complete with a steel profiled frame and are now designated as steel doorsets. The door leaves are normally designed to give a flush face with any joints hidden within the reveal of the frame. However, large size door leaves might result in the need for face joints where the size exceeds the maximum steel sheet size available. The top and bottom of the door has a flush or inverted channel section to make it a "box" section.

Steel door leaves are made from flat steel sheet which is "pierced" with holes and cut-outs for hinges, locks and vision panels prior to being folded and assembled.

A typical steel door assembly is shown in Figure B.1.

B.2 Lock seam

This type of construction is in the form of a "tray and lid" where the visible joint is a locked seam.

A typical section through a flush double doorset is shown in Figure B.2.

NOTE The construction of the door may vary according to material thickness or performance criteria.

B.3 Seamless

For certain applications, such as clean rooms, the edges of the door are spot welded and filled or continuously welded and smoothed to give a seamless appearance.

B.4 Over-rebated

Some types of door include a rebated edge which overlaps the door frame. A plan of a typical over-rebated doorset is shown in Figure B.3.

B.5 Door leaf cores

In order to infill the void in the middle of the steel box section a number of different materials are used as a core dependent on the location and application of the final doorset such as, thermal, acoustic, fire and security performance.

B.6 Honeycomb

Most commercially available steel doors use this material for the core. The material is impregnated cardboard bonded to the steel skins during the manufacturing process giving a rigid and strong product weighing only 25 kg/m².

This type of construction allows cutting of apertures for vision panels or ventilation devices and is used on fire and non-fire doors.

B.7 Stiffened

Where the core of the door is not rigid e.g. mineral wool or other insulation material the steel skins need to be reinforced using stiffeners. These can be vertical or horizontal in the form of a grid. The stiffeners are normally profiled and either spot welded or bonded to the steel skins and the insulation material fitted in the spaces between.

Figure B.1 Typical steel door assembly

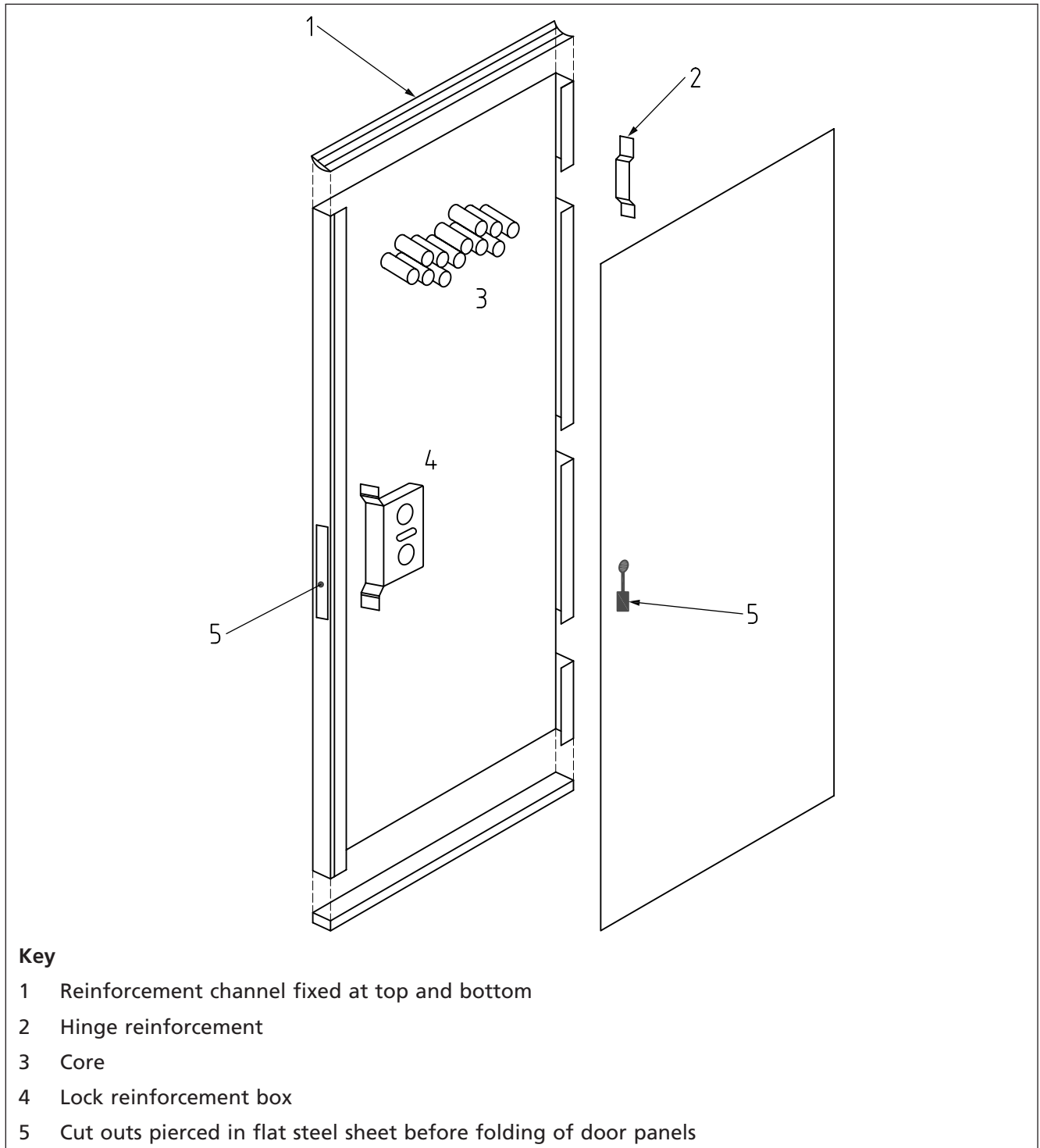

Figure B.2 Typical section through flush double doorset

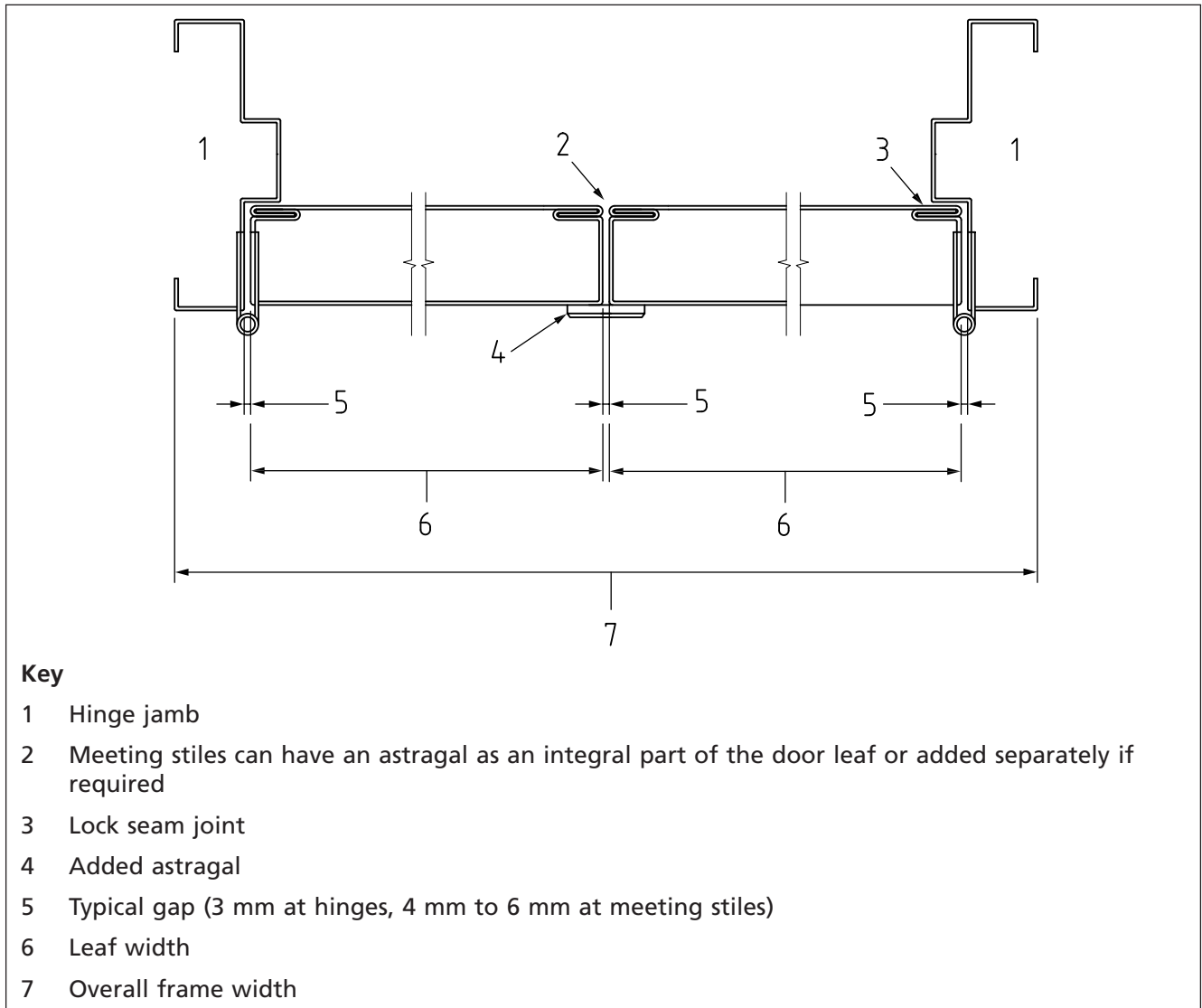
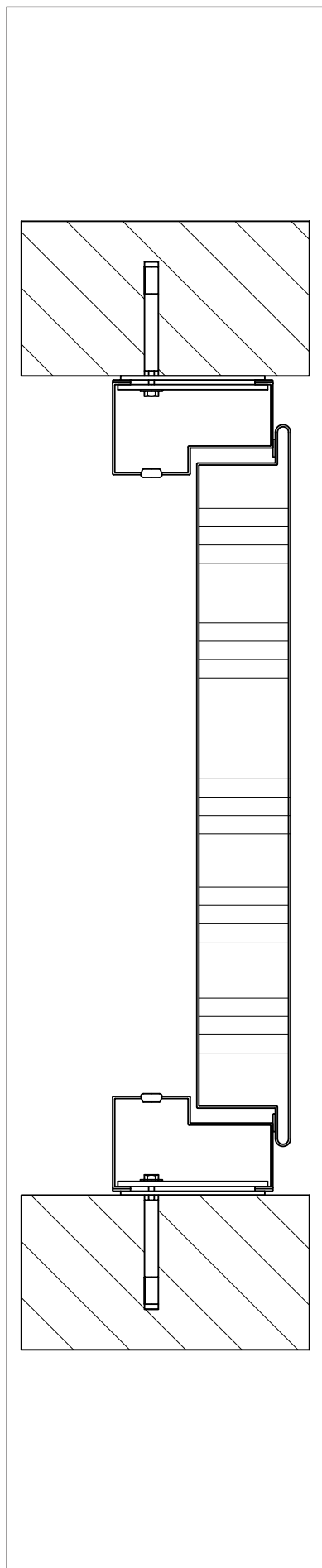

Figure B.3 Plan of a typical over-rebated doorset



Bibliography

Standards publications

For dated references, only the edition cited applies. For undated references, the latest edition of the referenced document (including any amendments) applies.

BS 8213-4, *Windows, doors and rooflights – Part 4: Code of practice for the survey and installation of windows and external doorsets*

BS 8300, *Design of buildings and their approaches to meet the needs of disabled people – Code of practice*

BS EN 14351-1, *Windows and pedestrian doorsets – Product standard, performance characteristics – Part 1: Windows and external pedestrian doorsets without resistance to fire and/or smoke leakage characteristics* ³⁾

Other publications

- [1] EUROPEAN COMMUNITIES. 89/106/EEC. Council Directive 89/106/EEC of 21 December 1988 on the approximation of laws, regulations and administrative provisions of the Member States relating to construction products. Luxembourg: Office for Official Publications of the European Communities, 1988.
- [2] GREAT BRITAIN. Building Regulations 2010. London: The Stationery Office.
- [3] SCOTLAND. Building (Scotland) Regulations 2004 and subsequent amendments. Edinburgh: The Stationery Office.
- [4] GREAT BRITAIN. Building Regulations (Northern Ireland) 2000 and subsequent amendments. Belfast: The Stationery Office.
- [5] GREAT BRITAIN. *The Building Regulations 2000 – Approved Document B – Fire safety*. (Volumes 1 and 2.) London: The Stationery Office, 2007.
- [6] STATIONERY OFFICE. *The Building Regulations 2000 – Approved Document M – Access to and use of buildings*. 2004 edition. London: The Stationery Office, 2006.

³⁾ Part 2 is in preparation. Part 3 (also in preparation) has been redesignated prEN 16034.

British Standards Institution (BSI)

BSI is the national body responsible for preparing British Standards and other standards-related publications, information and services.

BSI is incorporated by Royal Charter. British Standards and other standardization products are published by BSI Standards Limited.

About us

We bring together business, industry, government, consumers, innovators and others to shape their combined experience and expertise into standards-based solutions.

The knowledge embodied in our standards has been carefully assembled in a dependable format and refined through our open consultation process. Organizations of all sizes and across all sectors choose standards to help them achieve their goals.

Information on standards

We can provide you with the knowledge that your organization needs to succeed. Find out more about British Standards by visiting our website at bsigroup.com/standards or contacting our Customer Services team or Knowledge Centre.

Buying standards

You can buy and download PDF versions of BSI publications, including British and adopted European and international standards, through our website at bsigroup.com/shop, where hard copies can also be purchased.

If you need international and foreign standards from other Standards Development Organizations, hard copies can be ordered from our Customer Services team.

Subscriptions

Our range of subscription services are designed to make using standards easier for you. For further information on our subscription products go to bsigroup.com/subscriptions.

With **British Standards Online (BSOL)** you'll have instant access to over 55,000 British and adopted European and international standards from your desktop. It's available 24/7 and is refreshed daily so you'll always be up to date.

You can keep in touch with standards developments and receive substantial discounts on the purchase price of standards, both in single copy and subscription format, by becoming a **BSI Subscribing Member**.

PLUS is an updating service exclusive to BSI Subscribing Members. You will automatically receive the latest hard copy of your standards when they're revised or replaced.

To find out more about becoming a BSI Subscribing Member and the benefits of membership, please visit bsigroup.com/shop.

With a **Multi-User Network Licence (MUNL)** you are able to host standards publications on your intranet. Licences can cover as few or as many users as you wish. With updates supplied as soon as they're available, you can be sure your documentation is current. For further information, email bsmusales@bsigroup.com.

BSI Group Headquarters

389 Chiswick High Road London W4 4AL UK

Revisions

Our British Standards and other publications are updated by amendment or revision.

We continually improve the quality of our products and services to benefit your business. If you find an inaccuracy or ambiguity within a British Standard or other BSI publication please inform the Knowledge Centre.

Copyright

All the data, software and documentation set out in all British Standards and other BSI publications are the property of and copyrighted by BSI, or some person or entity that owns copyright in the information used (such as the international standardization bodies) and has formally licensed such information to BSI for commercial publication and use. Except as permitted under the Copyright, Designs and Patents Act 1988 no extract may be reproduced, stored in a retrieval system or transmitted in any form or by any means – electronic, photocopying, recording or otherwise – without prior written permission from BSI. Details and advice can be obtained from the Copyright & Licensing Department.

Useful Contacts:

Customer Services

Tel: +44 845 086 9001

Email (orders): orders@bsigroup.com

Email (enquiries): cservices@bsigroup.com

Subscriptions

Tel: +44 845 086 9001

Email: subscriptions@bsigroup.com

Knowledge Centre

Tel: +44 20 8996 7004

Email: knowledgecentre@bsigroup.com

Copyright & Licensing

Tel: +44 20 8996 7070

Email: copyright@bsigroup.com



...making excellence a habit.™