

BS 1139-6:2014



BSI Standards Publication

Metal scaffolding – Part 6: Prefabricated tower scaffolds outside the scope of BS EN 1004, but utilizing components from such systems – Specification

bsi.

...making excellence a habit.™

Publishing and copyright information

The BSI copyright notice displayed in this document indicates when the document was last issued.

© The British Standards Institution 2014

Published by BSI Standards Limited 2014

ISBN 978 0 580 83646 6

ICS 91.220

The following BSI references relate to the work on this document:

Committee reference B/514/24

Draft for comment 14/30286613 DC

Publication history

First published December 2005

Second (present) edition, December 2014

Amendments issued since publication

Date	Text affected
-------------	----------------------

Contents

Foreword *ii*

1	Scope	1
2	Normative references	1
3	Terms and definitions	2
4	General Requirements	13
5	Materials	13
6	Dimensions	13
7	Structural design	20
8	Verification	23
9	Markings	24
10	Information to be supplied with a prefabricated tower scaffold	25

Bibliography 27

List of figures

Figure 1	– Example of a cantilever tower scaffold	2
Figure 2	– Example of a large deck tower scaffold	3
Figure 3	– Example of a linked tower scaffold	4
Figure 4	– Example of a linked tower scaffold with bridge decks	5
Figure 5	– Example of a stepped tower scaffold	6
Figure 6	– Example of a high clearance frame	7
Figure 7	– Example of a walk through end frame at ground level	8
Figure 8	– Example of a step through end frame	8
Figure 9	– Example of a portal end frame	9
Figure 10	– Examples of bridge beams	10
Figure 11	– Example of a prefabricated tower scaffold cantilever platform	11
Figure 12	– Example showing a prefabricated tower scaffold of 2 bay lengths in Elevation A and 3 bays width in Elevation B	12
Figure 13	– Minimum clear height and width of a high clearance frame on the highway for the passage of the general public	14
Figure 14	– Minimum clear height and width of a walk through end frame for walk through frames not intended for use on the highway for the passage of the general public	15
Figure 15	– Minimum clear height and width for walk through end frames on the highway for the passage of the general public	16
Figure 16	– Minimum clear width for step through end frames	17
Figure 17	– Minimum clear width and height for portal end frames	18
Figure 18	– Maximum vertical distance between platforms used for assembly and dismantling	19

List of tables

Table 1	– Dimensions for portal end frames	17
Table 2	– Load classes	21

Summary of pages

This document comprises a front cover, an inside front cover, pages i to ii, pages 1 to 28, an inside back cover and a back cover.

Foreword

Publishing information

This part of BS 1139 is published by BSI Standards Limited, under licence from The British Standards Institution, and came into effect on 31 December 2014. It was prepared by Subcommittee B/514/24, *Access towers*, under the authority of Technical Committee B/514, *Access and support equipment*. A list of organizations represented on these committee can be obtained on request to their secretary.

Supersession

This part of BS 1139 supersedes BS 1139-6:2005, which is withdrawn.

Relationship to other standards

This part of BS 1139 should be read in conjunction with, and is complementary to, BS EN 1004, *Mobile access and working towers made of prefabricated elements — Materials, dimensions, design loads, safety and performance requirements*.

Information about this document

This is a full revision of the standard and introduces the following principal changes:

- clarification of the scope;
- updated terms and definitions;
- dimensions for certain components;
- new requirements for structural design and positional stability;
- new requirements for design verification;
- new requirements for marking and for the information to be supplied.

Presentational conventions

The provisions of this standard are presented in roman (i.e. upright) type. Its requirements are expressed in sentences in which the principal auxiliary verb is "shall".

Commentary, explanation and general informative material is presented in smaller italic type, and does not constitute a normative element.

Requirements in this standard are drafted in accordance with *The BSI guide to standardization – Section 2: Rules for the structure, drafting and presentation of British Standards*, subclause 11.3.1, which states, "Requirements should be expressed using wording such as: 'When tested as described in Annex A, the product shall ...'". This means that only those products that are capable of passing the specified test will be deemed to conform to this standard.

Contractual and legal considerations

This publication does not purport to include all the necessary provisions of a contract. Users are responsible for its correct application.

Attention is drawn to the Work at Height Regulations 2005 [1].

Compliance with a British Standard cannot confer immunity from legal obligations.

1 Scope

This part of BS 1139 specifies requirements for the structural design of prefabricated tower scaffolds utilizing components from mobile access and working towers specified in BS EN 1004 but in configurations that are outside of the scope of that standard.

These configurations include:

- a) prefabricated tower scaffolds outside the height limits of BS EN 1004;
- b) towers with more than one working platform;
- c) large deck tower scaffolds;
- d) linked tower scaffolds;
- e) cantilever tower scaffolds;
- f) stepped tower scaffolds;
- g) tower scaffolds used as a means of access;
- h) towers built on base plates instead of castors.

This British Standard applies to prefabricated tower scaffolds subject to wind loads up to and including 0.1 kN/m^2 .

NOTE Where a prefabricated tower scaffold might be subject to wind in excess of 0.1 kN/m^2 , and it cannot be dismantled or moved to avoid these winds, suitable wind design criteria can be found in BS EN 1991-1-4.

This British Standard does not cover prefabricated tower scaffolds using guys as a method of stabilization.

2 Normative references

The following referenced documents are indispensable for the application of this document. For dated references, only the edition cited applies. For undated references, the latest edition of the referenced document (including any amendments) applies.

BS EN 74 (all parts), *Couplers, spigot pins and baseplates for use in falsework and scaffolds*

BS EN 1004, *Mobile access and working towers made of prefabricated elements – Materials, dimensions, design loads, safety and performance requirements*

BS EN 1298, *Mobile access and working towers – Rules and guidelines for the preparation of an instruction manual*

BS EN 1999-1-1, *Eurocode 9: Design of aluminium structures – Part 1-1: General structural rules*

BS EN 12811-2, *Temporary works equipment – Part 2: Information on materials*

3 Terms and definitions

For the purposes of this part of BS 1139 the terms and definitions given in BS EN 1004 together with the following apply.

NOTE The figures in this clause are not working drawings.

3.1 prefabricated tower scaffold

structure made up from prefabricated components which have their dimensions fixed by the design and which are used in mobile access and working towers specified in BS EN 1004 but in one or more configurations that are outside the scope of that standard. It might be:

- a) be rendered moveable by the fitting of castor wheels or other mobility devices in contact with the supporting surface at the base, or be rendered static by the fitting of base plates in contact with that surface;
- b) be structurally self-supporting and/or self-stabilized, or be structurally supported and/or stabilised by:
 - 1) securing it to an adjacent supporting structure;
 - 2) using other methods which provide the required strength and stability;
- c) have one or more working platforms and intermediate access platforms

3.2 prefabricated tower scaffold configurations

3.2.1 cantilever tower scaffold

prefabricated tower scaffold with one or more projecting working platforms

NOTE See Figure 1 for an example.

Figure 1 Example of a cantilever tower scaffold



3.2.2 large deck tower scaffold

assembly of adjoining prefabricated tower scaffolds connected together laterally at their ends and sides

NOTE 1 See Figure 2 for an example.

NOTE 2 Large deck tower scaffolds are also known as birdcage towers or boxing ring towers.

Figure 2 Example of a large deck tower scaffold

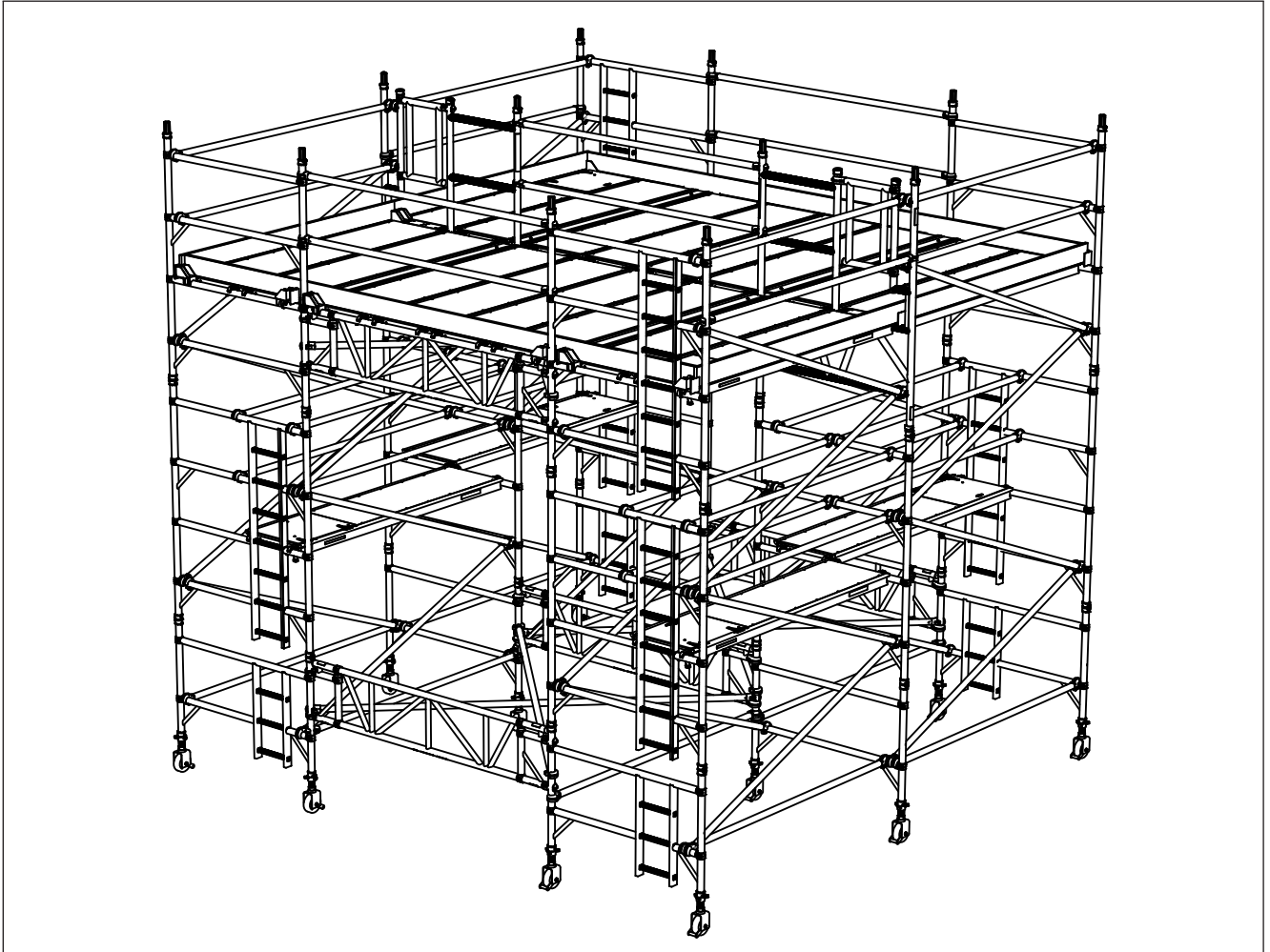

3.2.3 linked tower scaffold

assembly of adjoining prefabricated tower scaffolds connected together laterally at their ends or sides either by the sharing of end frames, or by the use of bridge decks or bridge beams

NOTE 1 See Figure 3 and Figure 4 for examples.

NOTE 2 Linked tower scaffolds are also known as façade towers.

NOTE 3 See 3.3.6 for definition of bridge beam and 3.3.7 for definition of bridge deck.

Figure 3 Example of a linked tower scaffold

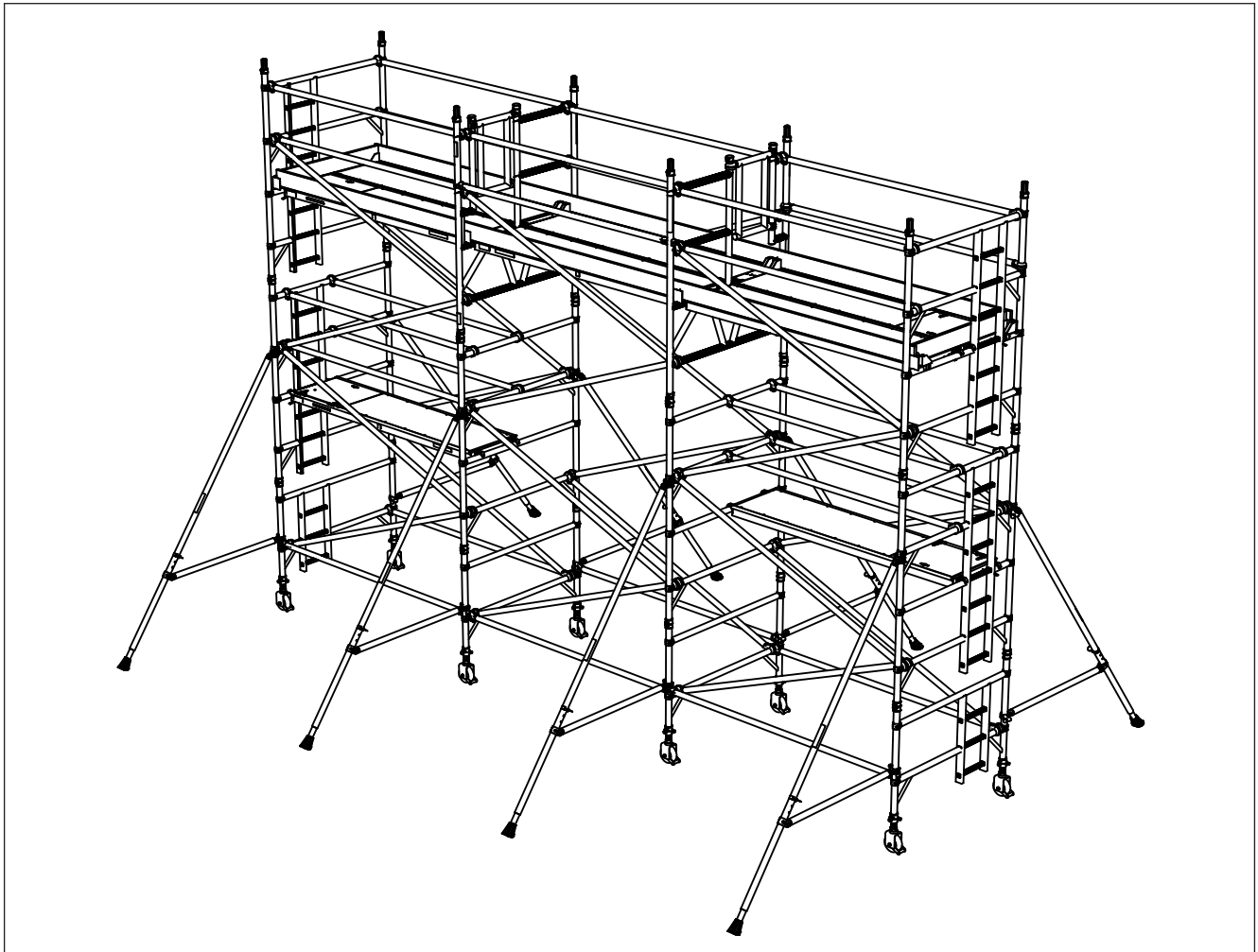
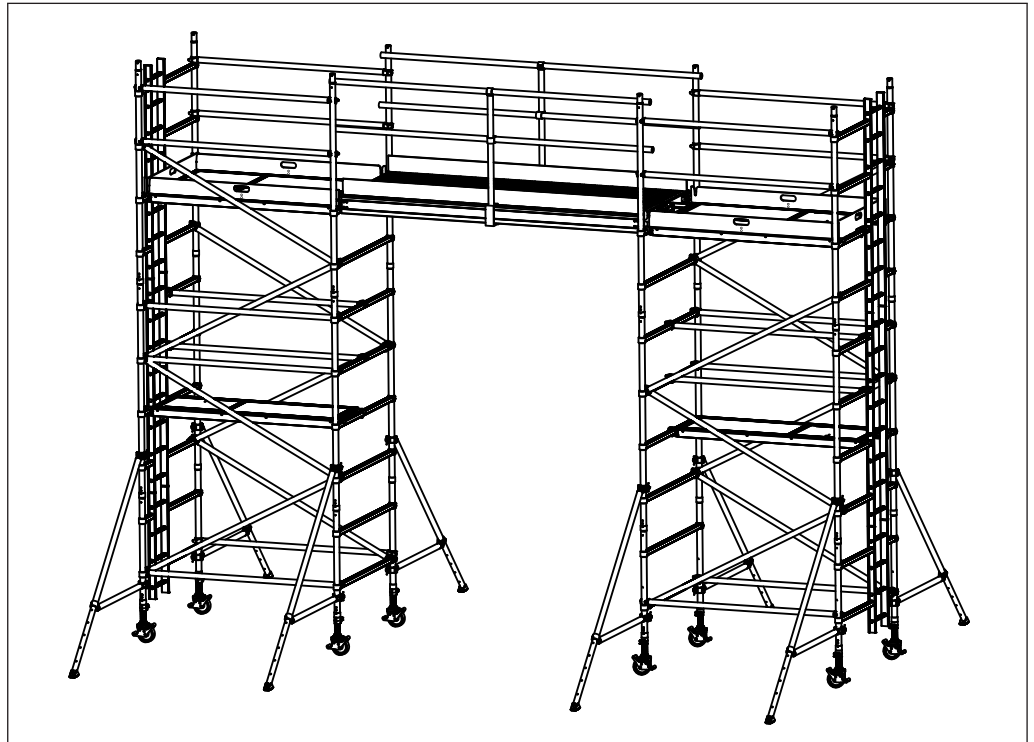

Figure 4 Example of a linked tower scaffold with bridge decks



3.2.4 stepped tower scaffold

prefabricated tower scaffold where the bases at the opposite ends of the tower are at different heights

NOTE Figure 5 shows an example of a stepped tower scaffold – a tower built on a staircase.

Figure 5 Example of a stepped tower scaffold

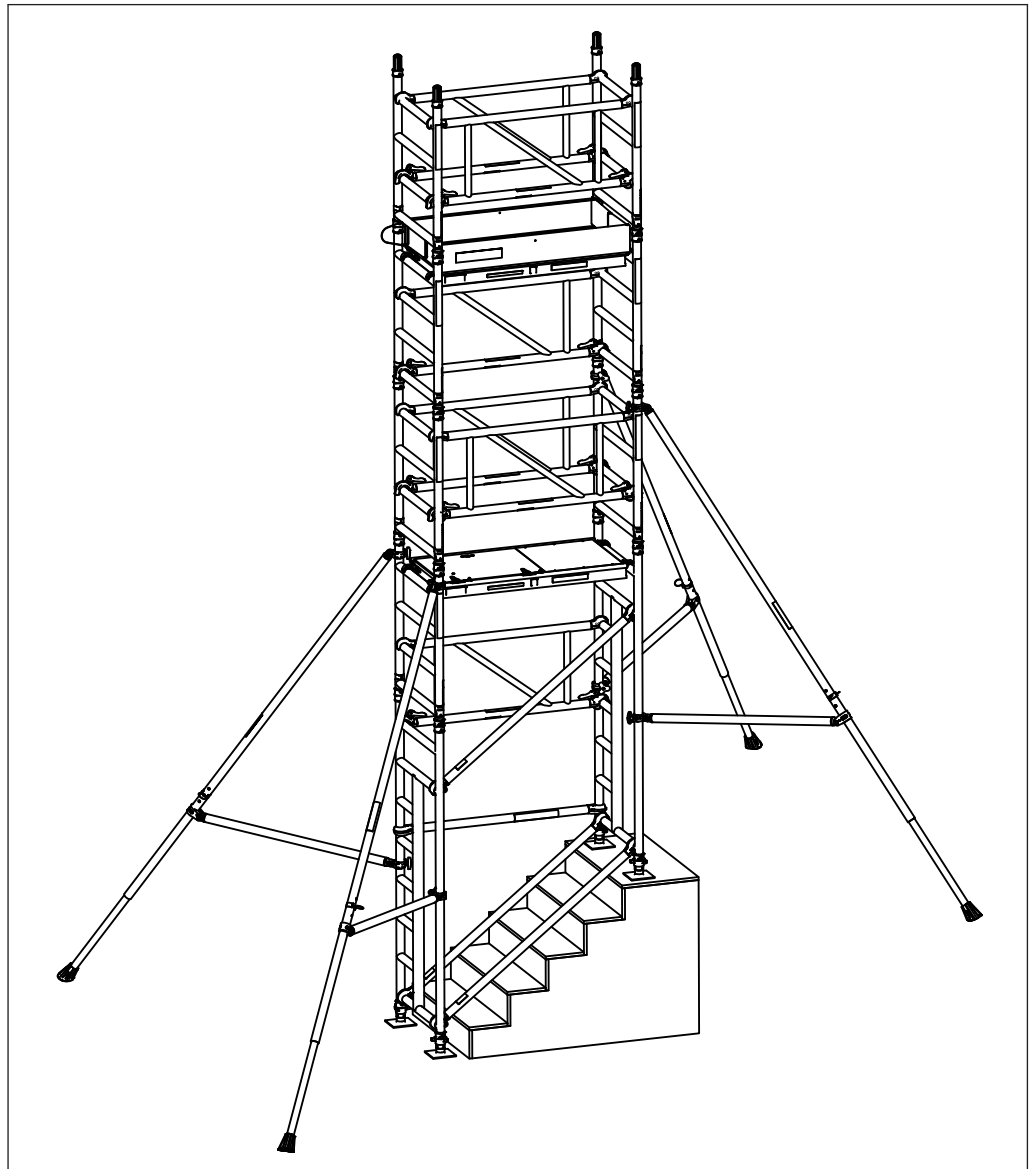

3.2.5 high level tower scaffold

prefabricated tower scaffold of any configuration where the uppermost platform is:

- more than 12 m from the ground when the tower is not subject to wind forces or;
- more than 8 m from the ground when the tower is subject to wind forces

NOTE Prefabricated tower scaffolds indoors might also be subject to wind forces.

3.3 prefabricated tower components

3.3.1 base plate

component secured to the base of a prefabricated tower scaffold to provide a support on the ground when movement of the tower is not required

3.3.2 high clearance frame

component which is installed at the base of a prefabricated tower scaffold and which provides unrestricted passage through the width of the tower at ground level or to span obstructions

NOTE 1 See Figure 6 for an example.

NOTE 2 High clearance frames are also known as goalpost frames.

Figure 6 Example of a high clearance frame

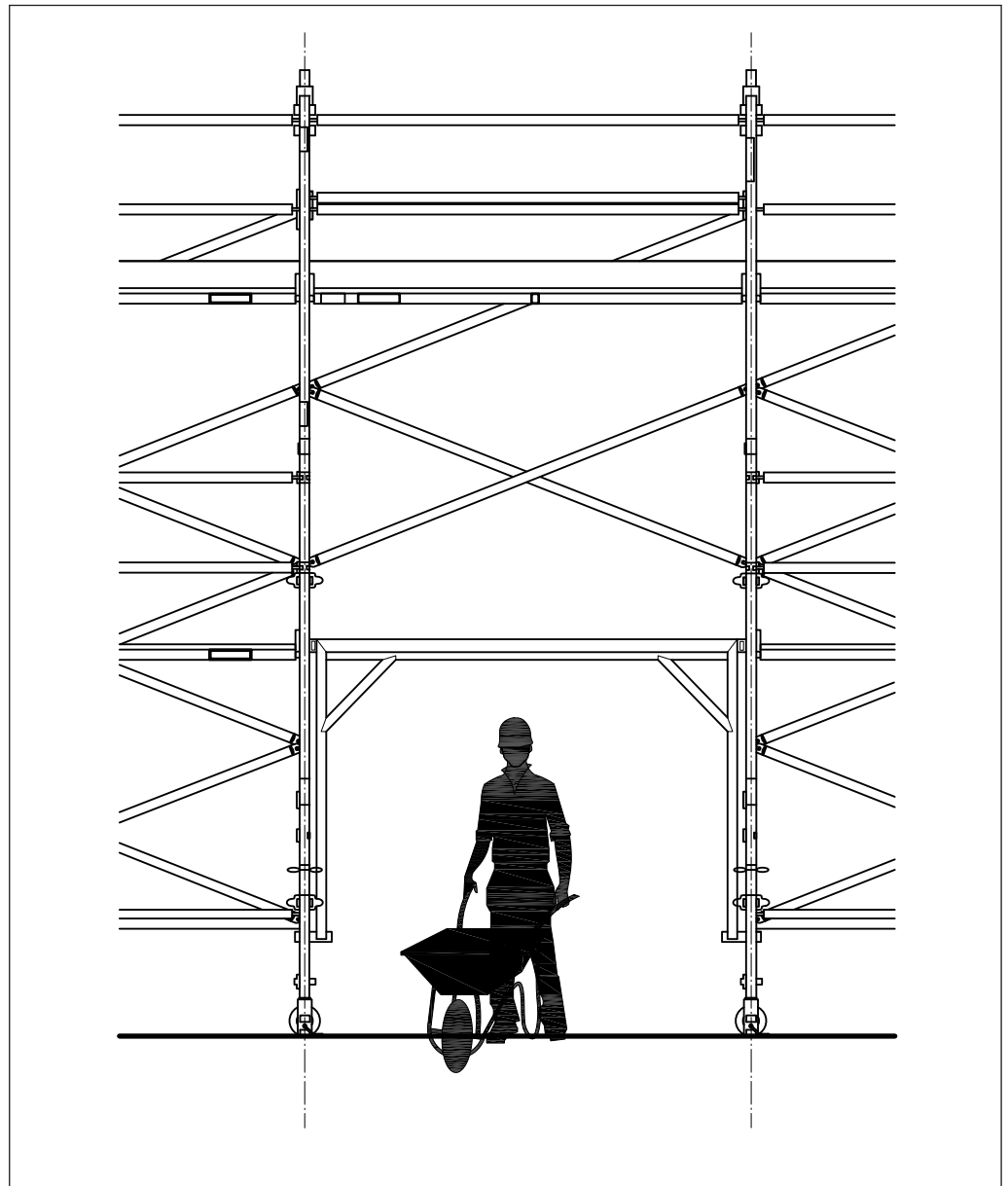

3.3.3 walk through end frame

component which provides unrestricted passage through the end frames of a tower

NOTE 1 See Figure 7 for an example.

NOTE 2 Walk through end frames are also known as pavement frames.

Figure 7 Example of a walk through end frame at ground level

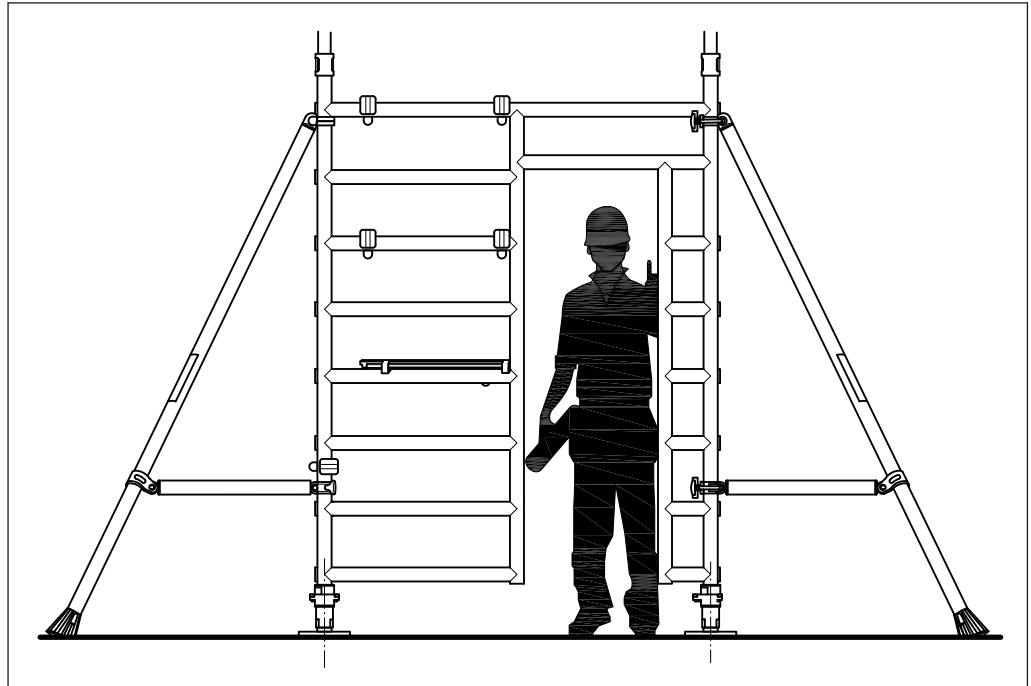

3.3.4 step through end frame

component which provides passage between the ends of adjoined towers at the uppermost platform level

NOTE See Figure 8 for an example.

Figure 8 Example of a step through end frame

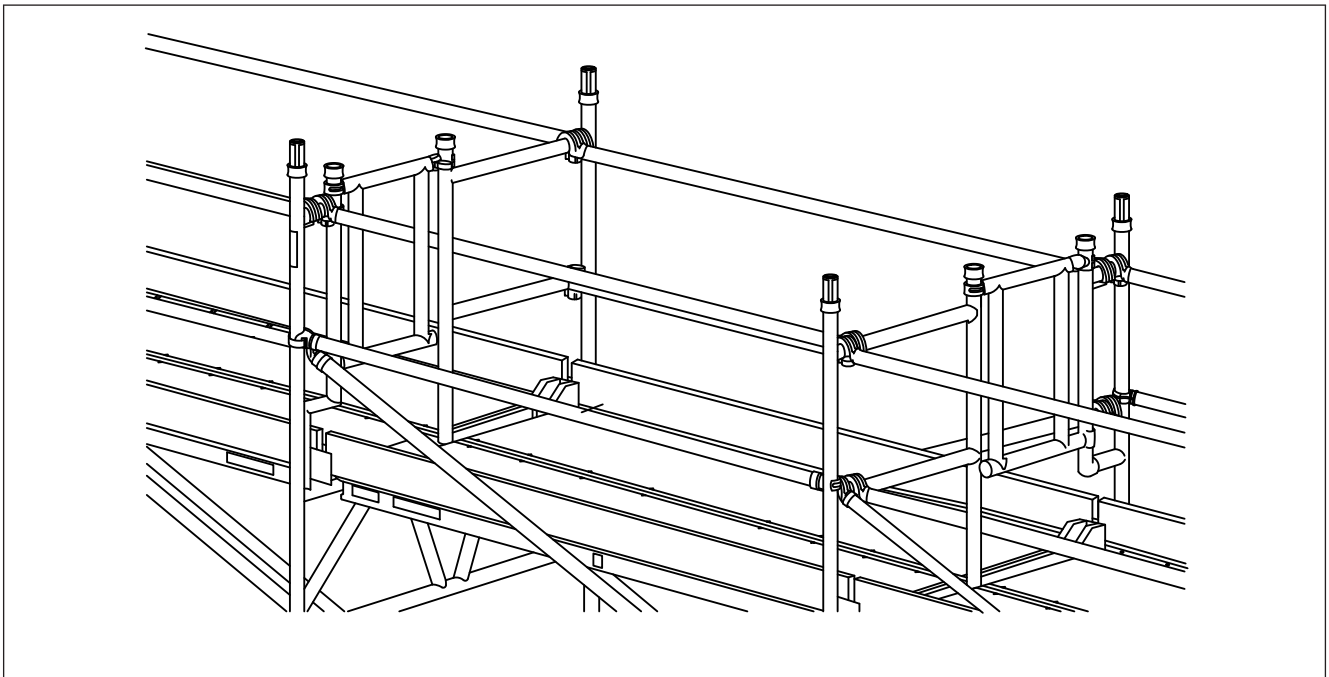

3.3.5 portal end frame

end frame with an aperture which enables passage through the ends of the tower

NOTE See Figure 9 for an example.

Figure 9 Example of a portal end frame

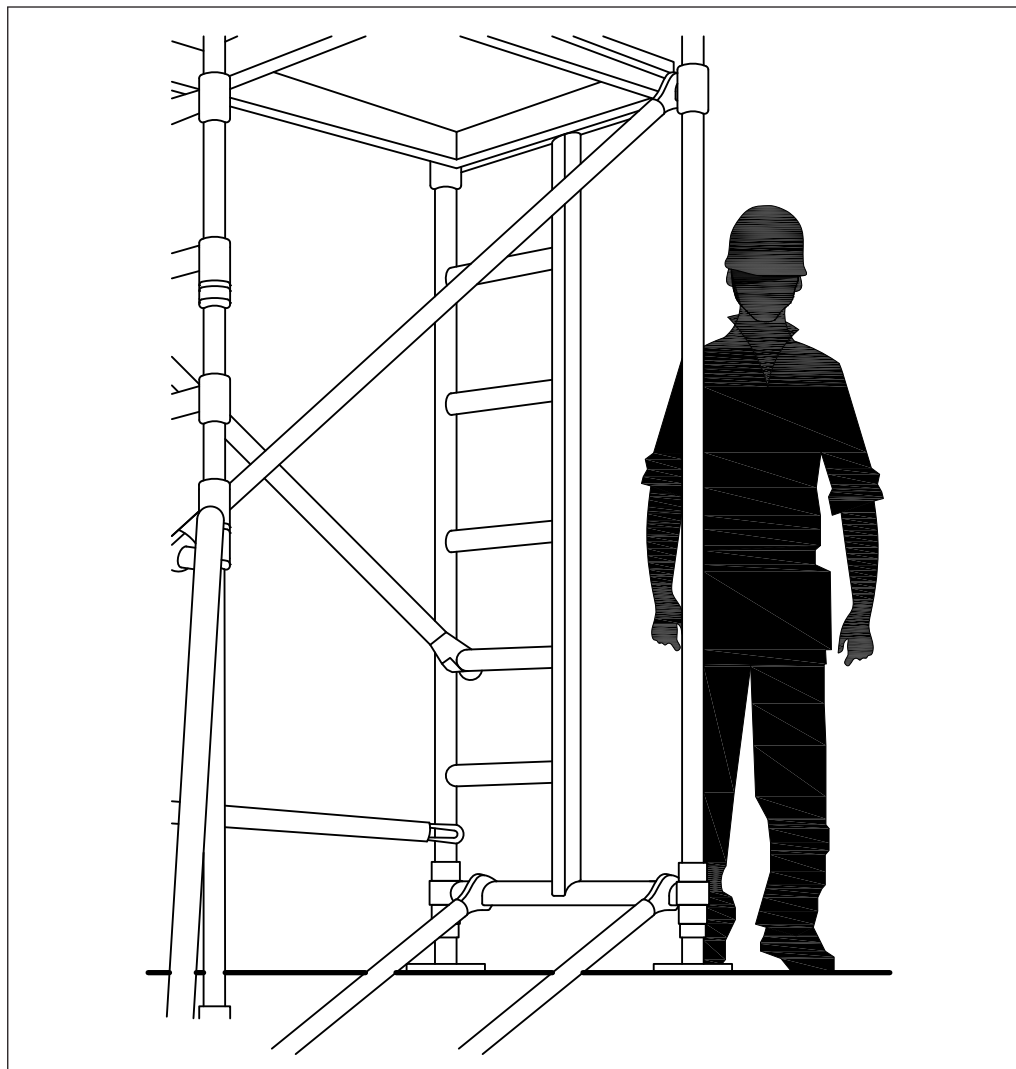

3.3.6 bridge beam

component which is used to connect two prefabricated tower scaffolds and might support the platform

NOTE See Figure 10 for an example.

Figure 10 Examples of bridge beams

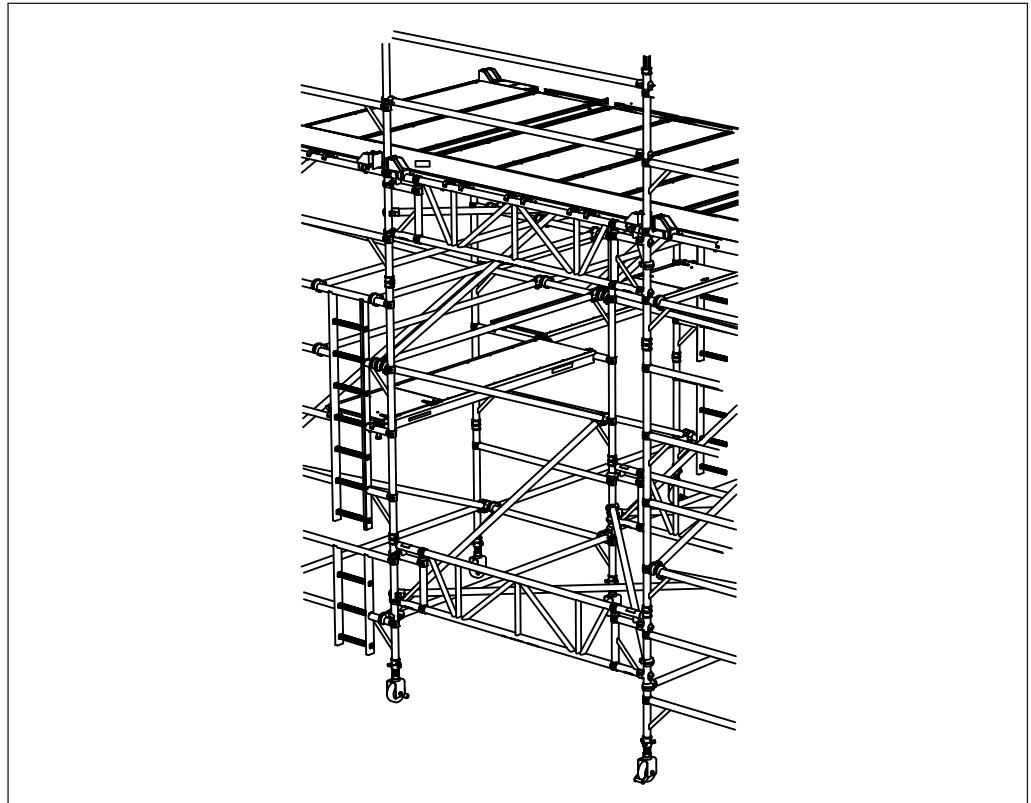
**3.3.7 bridge deck**

component which connects and creates a bridge between two prefabricated tower scaffolds

3.4 working platform level

platform unit or combination of platform units and/or cantilever platforms at the level at which the work task is undertaken

NOTE There might be more than one working platform.

3.5 access platform level

place to stand when installing or removing components of the tower when assembling, altering or dismantling the tower, or as a place to stand when ascending or descending the tower

3.6 platform unit

prefabricated unit which forms the platform or part of the platform of the prefabricated tower scaffold

3.7 cantilever platform

working platform which projects outwards from the side or end of, and is supported by, the prefabricated tower scaffold

NOTE See Figure 11 for an example.

Figure 11 Example of a prefabricated tower scaffold cantilever platform

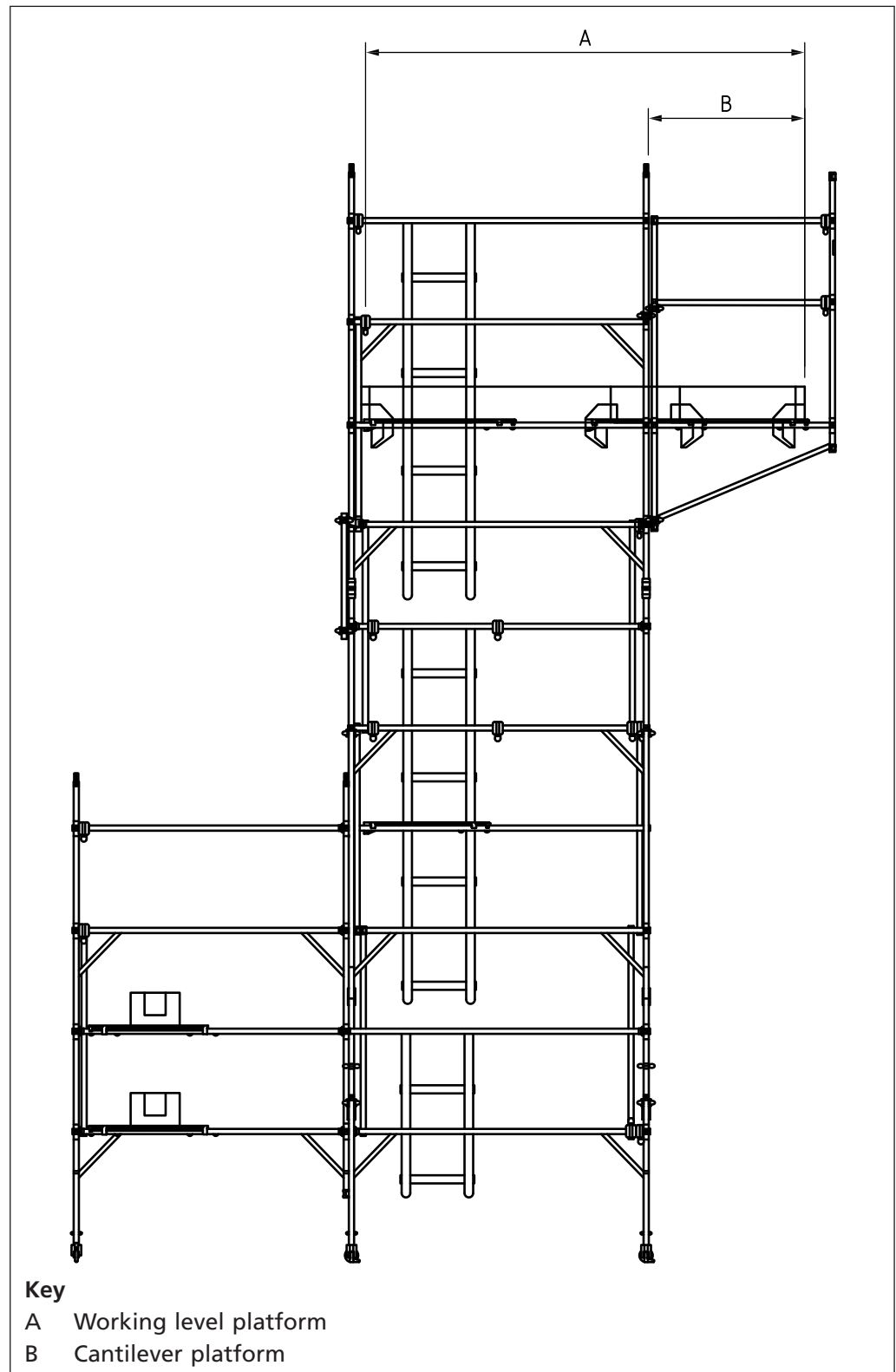

3.8 bay

vertical section between uprights of a prefabricated tower scaffold – through the entire length or width of the tower when viewed in elevation

NOTE See Figure 12 for an example.

Figure 12 Example showing a prefabricated tower scaffold of 2 bay lengths in Elevation A and 3 bays width in Elevation B

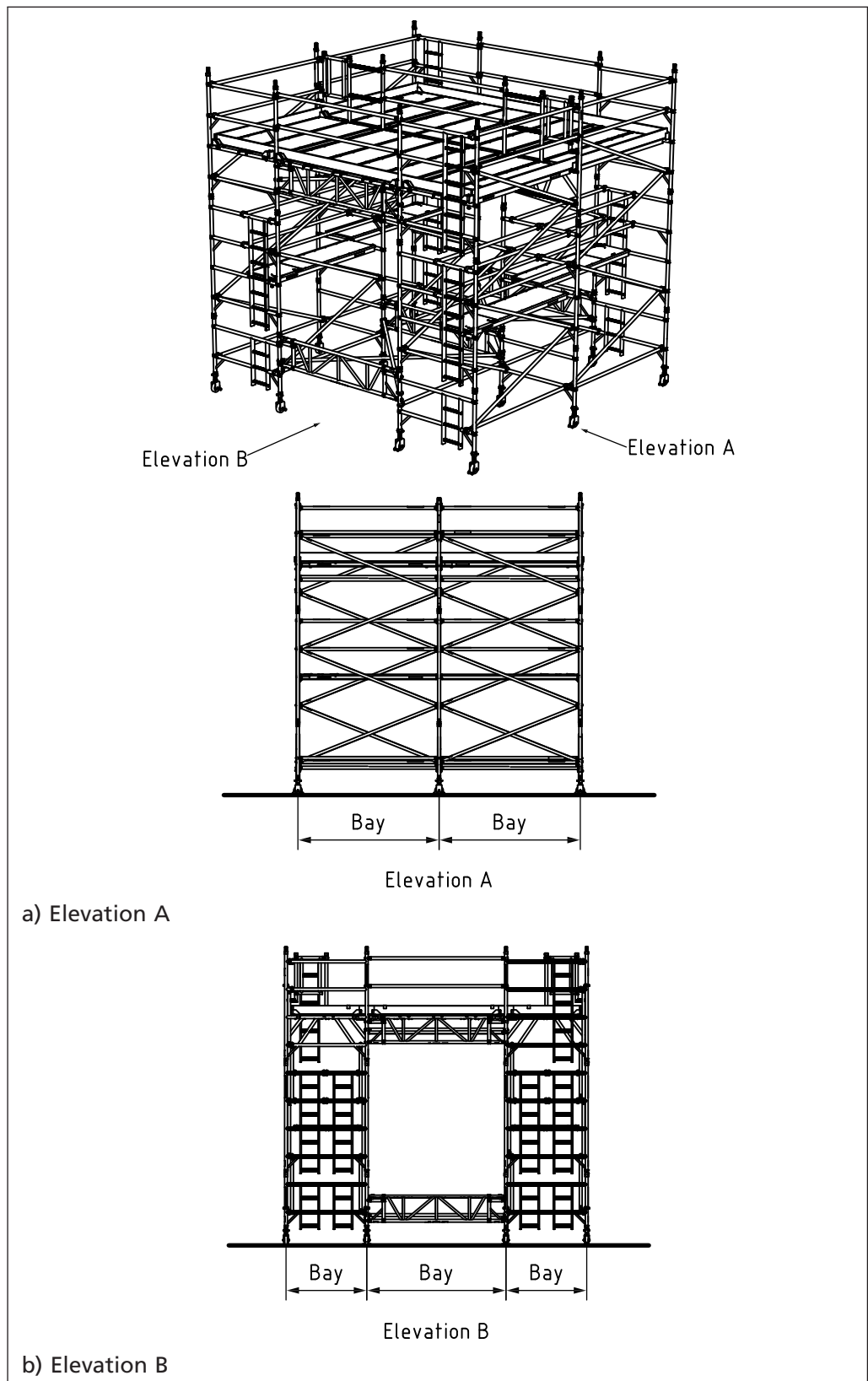

4 General Requirements

4.1 General

The requirements from BS EN 1004 shall apply with the exceptions given in this British Standard.

4.2 Load class

All prefabricated tower scaffolds shall be capable of supporting a uniformly distributed load (UDL) relevant to the nature of the work being undertaken (see 7.2.3).

4.3 Base plates

Base plates used in conjunction with a mobile tower shall conform to the requirements of BS EN 74.

4.4 Connectors

Connectors used to attach loose tubes used as structural members in prefabricated tower scaffolds shall conform to the relevant requirements of BS EN 74.

4.5 Ballast

If ballast is necessary, it shall be secured in position against displacement and unauthorized removal. The ballast shall be made of rigid materials such as steel or concrete. Ballasts shall not utilize liquid or granular materials.

5 Materials

5.1 The materials of prefabricated tower scaffolds shall conform to the material requirements of BS EN 1004.

5.2 Loose tubes used as structural members in prefabricated tower scaffolds shall conform to the relevant material requirements of BS EN 12811-2.

6 Dimensions

6.1 High clearance frames

6.1.1 When not intended for use on the highway for the passage of the general public, high clearance frames shall have a minimum clear height of 1.85 m and shall have a minimum clear width of 0.5 m.

6.1.2 When intended for use on the highway for the passage of the general public, high clearance frames shall have a minimum clear height of 2.44 m and a minimum clear width of 1.2 m.

NOTE 1 See Figure 13.

NOTE 2 Attention is drawn to the PASMA document "Guidance notes and application for a licence to assemble and use a mobile tower on the highway" [2] which gives guidance on the use of high clearance frames.

Figure 13 Minimum clear height and width of a high clearance frame on the highway for the passage of the general public

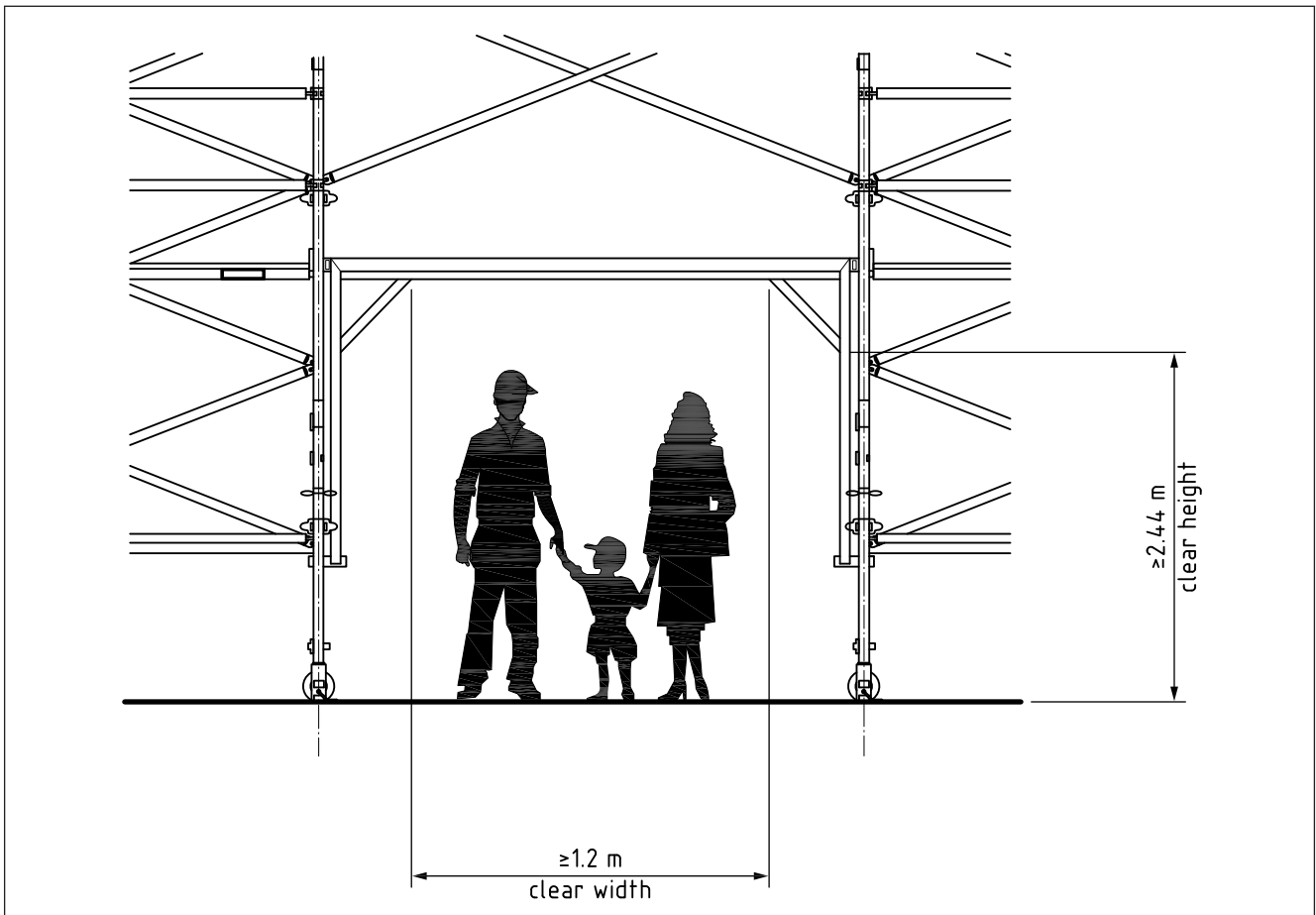

6.2 Walk through end frames

6.2.1 When not intended for use on the highway for the passage of the general public, walk through end frames shall have a minimum clear height of 1.85 m and shall have a minimum clear width of 0.5 m.

NOTE See Figure 14.

Figure 14 Minimum clear height and width of a walk through end frame for walk through frames not intended for use on the highway for the passage of the general public

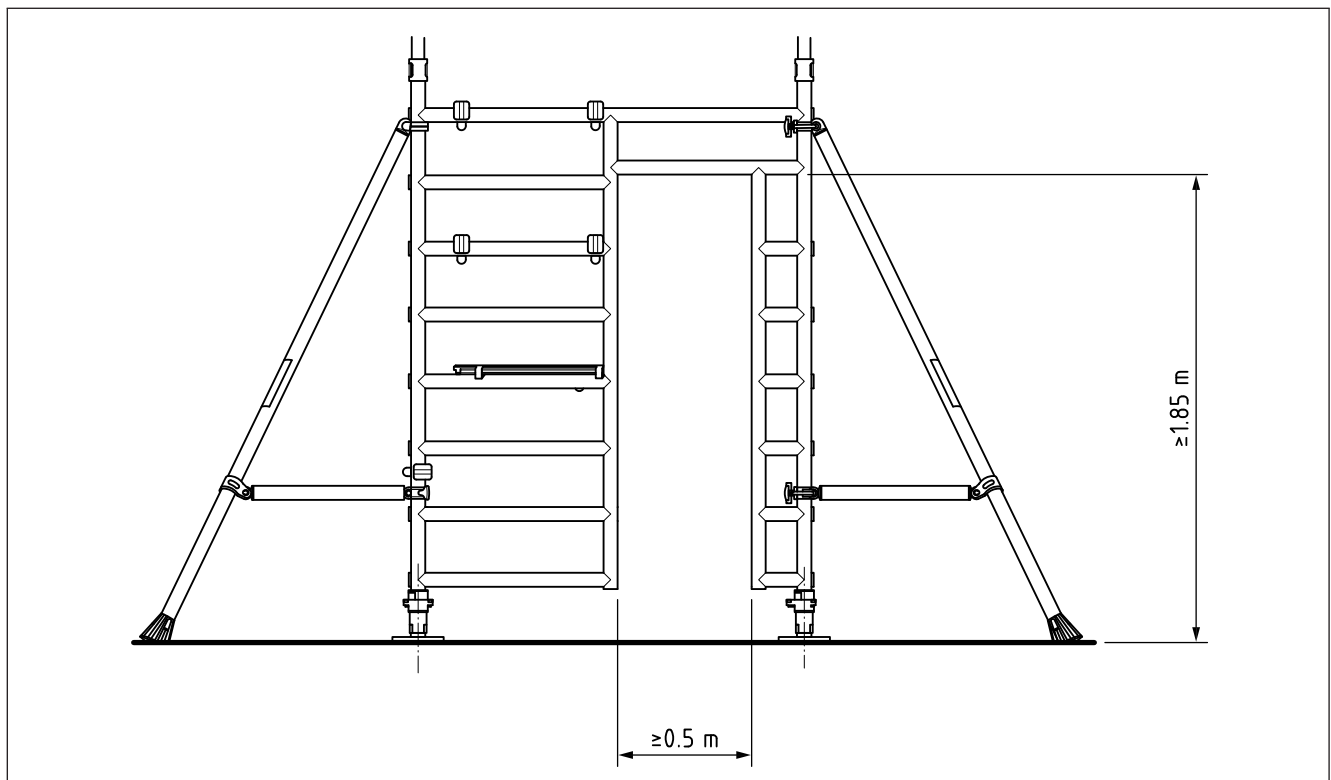

6.2.2 When intended for use on the highway for the passage of the general public, walk through end frames shall have a minimum clear height of 2.44 m and shall have a minimum clear width of 1.2 m.

NOTE 1 See Figure 15.

NOTE 2 Attention is drawn to PASMA guidance document "Guidance notes and application for a licence to assemble and use a mobile tower on the highway" [2].

Figure 15 Minimum clear height and width for walk through end frames on the highway for the passage of the general public



6.3 Step through end frames

Step through end frames shall have a minimum clear width of 0.5 m.

NOTE See Figure 16.

Figure 16 Minimum clear width for step through end frames

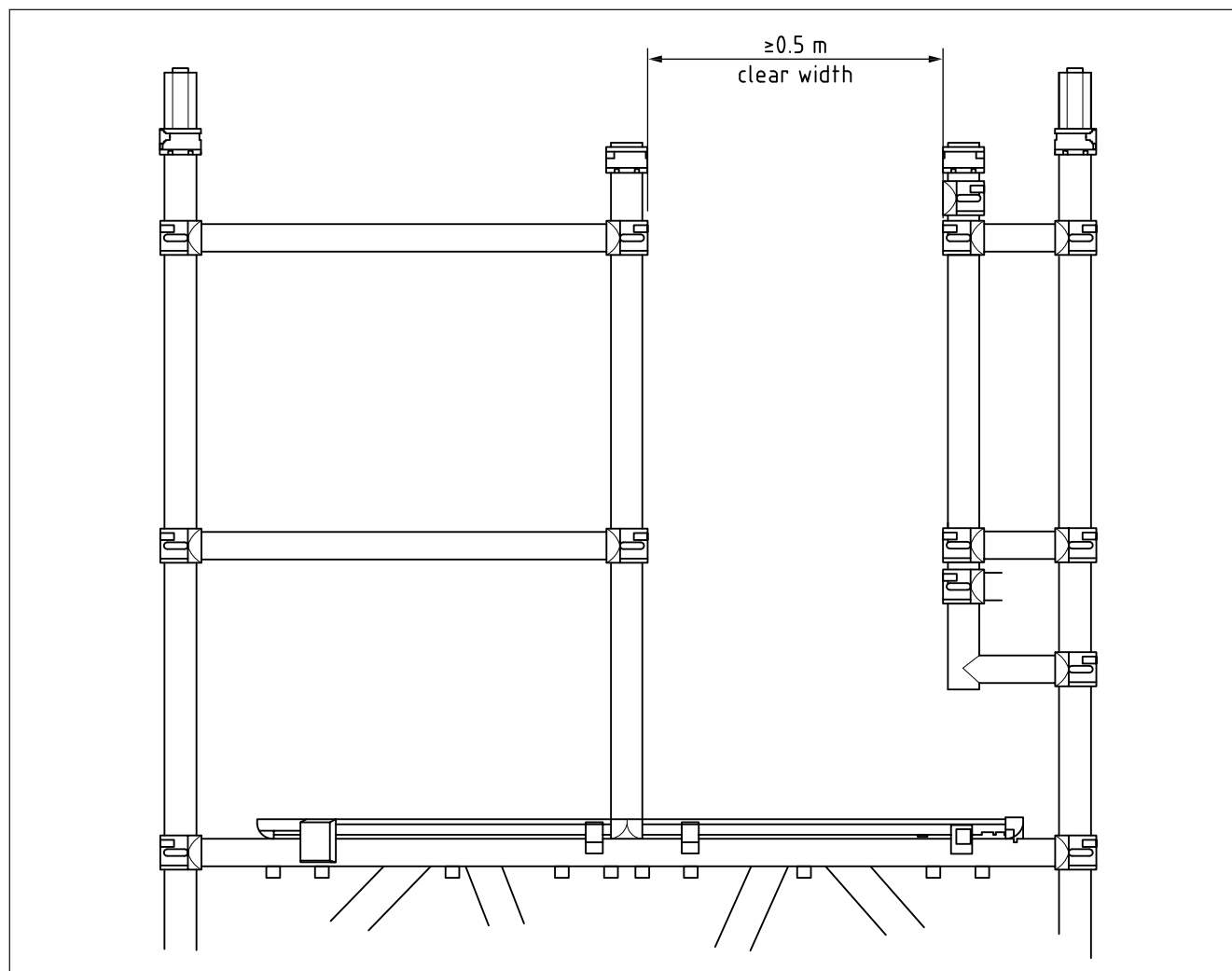

6.4 Portal end frames

Portal end frames shall have a minimum clear width as specified in Table 1.

NOTE 1 See also Figure 17.

NOTE 2 Portal end frames are not intended for passage by the general public.

Table 1 Dimensions for portal end frames

Frame width (W) m	Minimum clear width (CW) m
<0.85	0.4
≥ 0.85	0.5

Figure 17 Minimum clear width and height for portal end frames

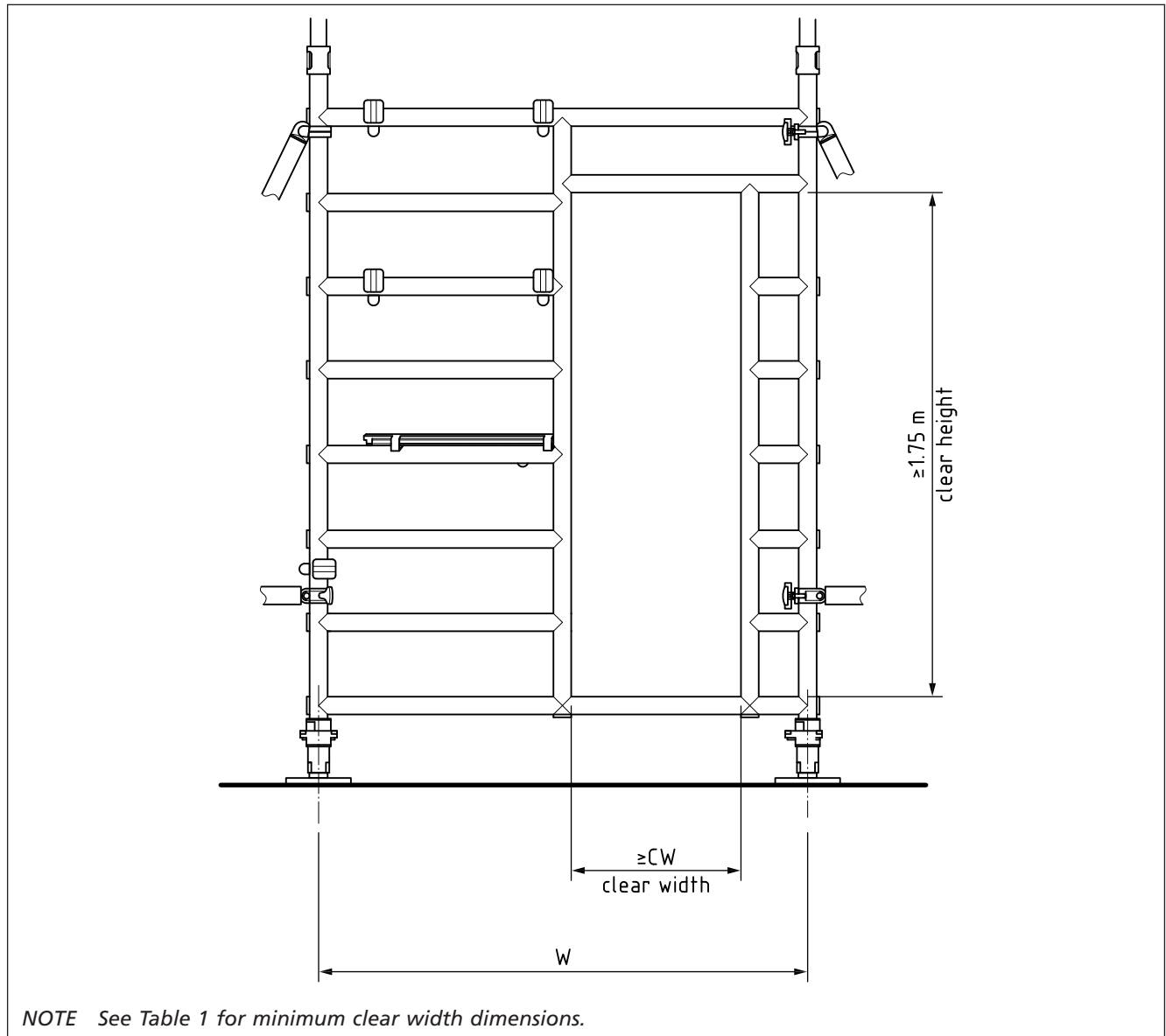

6.5 Vertical distances between platforms

The maximum vertical distance between platforms used for the assembly and dismantling of a prefabricated tower scaffold shall be 2.1 m.

NOTE See Figure 18.

Figure 18 Maximum vertical distance between platforms used for assembly and dismantling

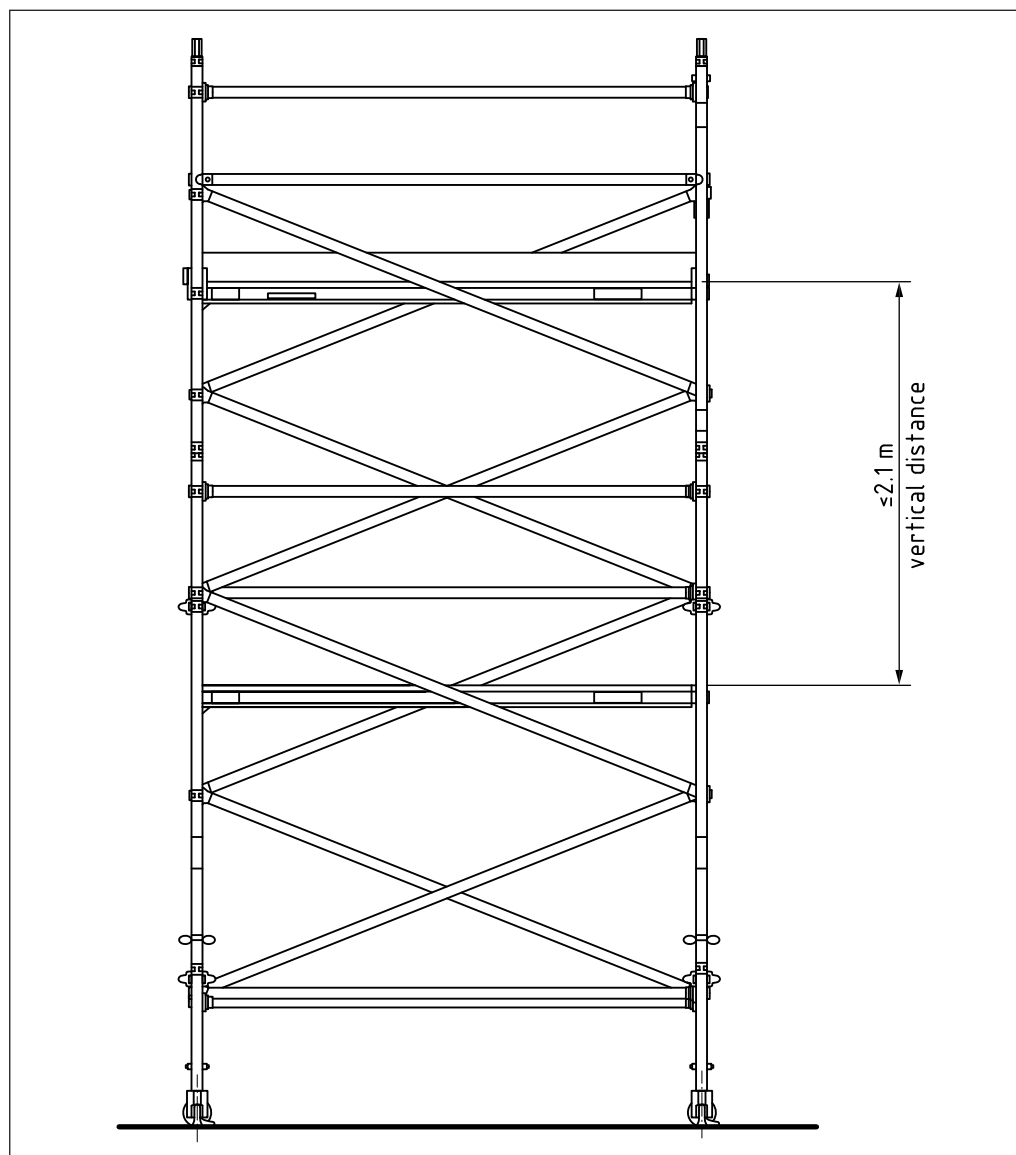

6.6 Gaps between adjoining platform units

Gaps between the ends and sides of adjoining platform units in the horizontal plane shall not exceed 25 mm in width.

6.7 Side protection to platforms

6.7.1 All platforms shall be fitted with principal guardrails and intermediate side protection in accordance with BS EN 1004.

6.7.2 Working platforms shall be fitted with toe boards in accordance with BS EN 1004.

7 Structural design

7.1 General

7.1.1 The structural design requirements of prefabricated tower scaffolds specified in 7.1.2 to 7.3 shall be applied, together with the structural design requirements given in BS EN 1004.

NOTE 1 In addition to designing for use, designers should consider structural strength and positional stability during assembly and dismantling of the prefabricated tower scaffold.

NOTE 2 When using anchors in concrete and masonry to tie a prefabricated scaffold structure to a supporting structure refer to BS 8539.

7.1.2 Prefabricated tower scaffolds shall be structurally and positionally stable in accordance with the load combinations given in 7.2.4.

7.1.3 For prefabricated tower scaffolds with cantilever platforms, in addition to the requirements of 7.1.2, the requirements of 7.2.5 shall apply.

7.1.4 Any bespoke components included as part of the prefabricated tower scaffold shall be verified by design calculation and testing in accordance with BS EN 1004.

7.1.5 All platforms, including platforms incorporated for access, assembly and dismantling, shall be included in the structural design calculations.

7.1.6 Design calculations for prefabricated tower scaffolds shall assume that any adjustable legs are fully extended and eccentricities of castors are considered in the least favourable position.

7.1.7 Design calculations for welded aluminium prefabricated tower structures shall take into account the effect of heat affected zones in accordance with the requirements of BS EN 1999-1-1.

7.1.8 All actions in this British Standard shall be taken as characteristic static loads.

7.1.9 Calculation models shall consider the actual weights of the components.

7.2 Actions

7.2.1 General

The actions from BS EN 1004 shall apply with the exceptions given in 7.2.2 to 7.2.5 of this standard.

7.2.2 Horizontal actions

7.2.2.1 Horizontal service loads

Prefabricated tower scaffolds shall be designed for horizontal service loads of:

- a) 0.3 Kilonewtons (kN) per bay for bays ≤ 4 m in length and;
 - b) 2×0.3 kN per bay for bays > 4 m in length,
- applied at the working platform level(s).

The maximum number of horizontal service loads shall not be greater than the number of persons permitted on the prefabricated tower scaffold.

7.2.2.2 Wind loads

7.2.2.2.1 Wind loads on the structure

Calculations for wind loads shall apply an aerodynamic force co-efficient (shape factor) of 1.3 for all projected areas of the prefabricated tower scaffold.

7.2.2.2.2 Wind loads on persons

For the purpose of design calculations, the wind loads shall be in accordance with the requirements of BS EN 1004. In addition, the design calculations shall consider the wind load based on the maximum number of persons permitted on the prefabricated tower scaffold.

For each person permitted on the structure, the design calculations shall consider a wind load of 0.1 kN/m² multiplied by a shape factor of 1 over a projected area of 0.7 m² at a height of 1 m above the platform level.

7.2.3 Load classes

For each of the load classes, the uniformly distributed load (UDL) requirements, as given in Table 2, shall be used.

For prefabricated tower scaffolds of load class 1, all platform units shall be capable of supporting a load class 2 service load, but this shall not apply to the scaffold structure in its entirety.

Table 2 Load classes

Load class	Uniformly Distributed Load (UDL) (kN/m ²)
1 ^{A)}	0.75
2	1.5
3	2.0

^{A)} Load class 1 is for very light duty work such as inspection or painting.

7.2.4 Load combinations

7.2.4.1 Structural stability

The prefabricated tower scaffold shall be evaluated separately in both load directions (parallel and perpendicular to the tower) for each load combination.

A prefabricated tower scaffold shall be able to resist the following combination of actions on the structure at ultimate limit state:

- the self-weight of the prefabricated tower scaffold including ballast if applicable;
- a UDL appropriate to the load class applied at the working platform level(s);
- a horizontal service load as specified in 7.2.2.1;
- loads resulting from an inclined position of 1% and joint imperfections and;
- a horizontal wind load on the structure in accordance with 7.2.2.2.1 and BS EN 1004.

Item e) shall be omitted from the load combination if the prefabricated tower scaffold is not exposed to wind (e.g. used indoors where no wind forces occur).

NOTE A prefabricated tower scaffold used internally might be subjected to wind e.g. positioned adjacent to a significant opening or in a tunnel.

7.2.4.2 Positional stability

7.2.4.2.1 General

Prefabricated tower scaffolds shall be able to resist overturning when calculated in accordance with 7.2.4.2.2, 7.2.4.2.3, and 7.2.4.2.4.

The prefabricated tower scaffold shall be evaluated separately in both load directions (parallel and perpendicular to the tower) for each load combination.

The factor of safety against overturning for the in service conditions specified in 7.2.4.2.2 and 7.2.4.2.3 shall be ≥ 1.5 .

The factor of safety against overturning for the out of service condition specified in 7.2.4.2.4 shall be ≥ 1.3 .

7.2.4.2.2 In service condition 1

Joint imperfections and inclination of 1% shall be taken into account.

Prefabricated tower scaffolds shall be calculated to resist a combination of:

- a) the vertical forces comprising of:
 - 1) the self-weight of the structure, including ballast if applicable, and;
 - 2) a 0.75 kN point load applied 100 mm from the most unfavourable edge of the working platform multiplied by the maximum number of persons permitted on the structure;
- b) the horizontal forces comprising of:
 - 1) a wind load on the person in accordance with 7.2.2.2.2 and;
 - 2) a wind load on the structure in accordance with 7.2.2.2.1 and BS EN 1004.

7.2.4.2.3 In service condition 2

Joint imperfections and inclination of 1% shall be taken into account.

Prefabricated tower scaffolds shall be calculated to resist a combination of:

- a) the vertical forces comprising of:
 - 1) the self-weight of the structure (including ballast if applicable), and;
 - 2) a 0.75 kN point load applied 100 mm from the most unfavourable edge of the working platform multiplied by the maximum number of persons permitted on the structure and;
- b) the horizontal forces comprising of a horizontal service load in accordance with 7.2.2.1.

7.2.4.2.4 Out of service condition

Joint imperfections and inclination of 1% shall be taken into account.

Prefabricated tower scaffolds shall be calculated to resist a combination of:

- a) the vertical forces comprising of the self-weight of the structure (including ballast if applicable) and;
- b) the horizontal forces comprising of a wind load on the structure as given in 7.2.2.2.1 and BS EN 1004.

7.2.5 Actions on cantilever tower scaffolds

Cantilever tower scaffolds shall be calculated for structural and positional stability in accordance with this British Standard with the exception that the factor of safety against overturning specified in 7.2.4.2.2 and 7.2.4.2.3 shall be increased to at least 3 when calculating the direction of the overturning moment imposed by loads from the cantilever platform(s).

When calculating in accordance with 7.2.4.2, the 0.75 kN point load shall be increased to 1.3kN.

NOTE Attention is drawn to HSE research report "RR342 Revision of body size criteria in standards – Protecting people who work at height" [3] which states, "It is likely (95% confidence) that the interval 112.3 kg-118.4 kg covers the true value of the 95th percentile for Weight Without Equipment and the interval 116.2 kg-122.0 kg covers the true value of the 95th percentile for Working Weight". The detailed results are in section 11.1 and 11.2 of the report.

The maximum number of persons on a working platform, incorporating a cantilever platform (see Figure 11), shall not exceed the maximum number of persons of the cantilever platform.

7.3 Structural deflection limits

Prefabricated tower scaffolds shall be limited for serviceability by maximum horizontal deflection when measured from the unloaded condition at the uppermost platform level.

When subjected to the actions given in 7.2.4.1, prefabricated tower scaffolds shall not deflect more than

$$\frac{h}{100} = d$$

where:

- h is the height of the uppermost platform level
- d is the deflection up to a maximum of 100 mm in any horizontal direction.

8 Verification

8.1 Verification report

A verification report shall be created by the designer as evidence of compliance with this standard. The verification report shall be checked by someone other than the designer. The verification report shall include as a minimum:

- a) identification of the evaluated configuration;
- b) identification of the particular set of components examined;
- c) structural data for components and connections as resistances and stiffnesses evaluated by tests;
- d) a detailed structural analysis in accordance with the requirements of this British Standard;
- e) confirmation of compliance with the requirements of this British Standard;
- f) a list of supporting documents including design drawings and assembly, use and dismantling instructions;
- g) the name and signature of the designer and the person who checked the report;

- h) document identity and date of issue.

8.2 Design certificate

The design certificate shall provide summary evidence that an adequate assessment of the prefabricated tower scaffold structure has been made in accordance with the requirements of this British Standard. The design certificate shall include as a minimum:

- a) identification of the evaluated configuration;
- b) identification of the components to which the design certificate applies;
- c) the design standards to which the components conform;
- d) specific notes regarding the safe use of the evaluated configuration;
- e) identification of relevant supporting documents including design drawings and assembly, use and dismantling instructions;
- f) the name and signature of the person responsible for issuing the design certificate;
- g) document identity and date of issue.

9 Markings

Markings shall be in accordance with the marking requirements of BS EN 1004.

Where the information on any marking on any individual component of a prefabricated tower scaffold regarding the safe working load of that component is incorrect because of the configuration in which the tower is built, then the correct information shall be displayed prominently at the base of the tower.

NOTE An example might be where the standard marking for a platform shows a maximum safe working load but because of the configuration in which the tower is built, that load is reduced.

Additionally, the following information shall be displayed prominently at the base of the tower:

- a) the maximum number of simultaneous working platforms permitted;
- b) the maximum number of persons permitted on the working platform(s) during use;
- c) the maximum number of persons permitted on the tower during assembly and dismantling;
- d) the maximum number of persons permitted on any one platform;
- e) the maximum safe working load on working platforms;
- f) the maximum safe working load on the prefabricated tower scaffold;
- g) the load class of the prefabricated tower scaffold.

10 Information to be supplied with a prefabricated tower scaffold

10.1 General

The information specified in Clause 9 shall be included in the information supplied with a prefabricated tower scaffold.

10.2 Assembly, use and dismantling instructions

For each type of prefabricated tower scaffold, an instruction manual or other assembly, use and dismantling plan shall be produced for use on-site and shall include, as a minimum, the information and instructions specified in BS EN 1298.

NOTE Attention is drawn to Work at Height Regulations 2005, Schedule 3, Part 2, Paragraph 8 [1].

Additionally the following instructions shall be included:

Platforms must be installed with vertical distances between them not exceeding 2.1 m when assembling and dismantling.

The maximum number of people on a working platform level permitted to simultaneously exert a horizontal load of 30 kg is:

- 1 person per bay for bays less than 4 m in length and;
- 2 persons per bay for bays greater than 4 m in length.

The weather forecast must be taken into account before use.

10.3 Anchors, ties and ballast

Information on the selection and installation of anchors or ties, including any tie loads, and/or quantities of ballast shall be supplied with any tower that is not self-supporting and/or self-stabilized. The information shall include the following instruction:

When used, select and install anchors in concrete and masonry must be selected and installed in accordance with BS 8539.

This prefabricated tower scaffold has been designed to be properly secured to a suitable adjacent supporting structure capable of withstanding the forces that will be imposed upon it by the attachment of the tower. Devices for securing the tower must be simultaneously rigid in both tension and compression and capable of withstanding and transmitting the loads imposed by the tower to the supporting structure.

If ballast is necessary, it must be secured in position and made of rigid materials such as steel or concrete, but excluding liquids or granular materials.

10.4 Leg loads

Information on the maximum point loads (leg loads) imposed by the prefabricated tower scaffold on its supporting surface shall be supplied.

10.5 Use of prefabricated scaffolds for access to adjacent structures

When a prefabricated scaffold tower is used as a means of access to another place (for example a flat roof) the user information shall include the following:

NOTE Attention is drawn to Work at Height Regulations 2005 Schedule 2, Paragraph 5 [1].

The tower must be built on base plates and properly secured to an adjacent supporting structure to prevent movement of the tower away from the structure at the point of access.

There must be no gap between the platform of the prefabricated scaffold tower and the place being accessed through which a person, tools or materials could fall or partially fall or which could cause a person to trip.

The platform of the prefabricated scaffold tower and the surface onto which a person will step when accessing another place must be at the same level.

Means of protection must be removed only for the time and to the extent necessary to gain access or egress or for the performance of a particular task and must be replaced as soon as practicable. The task must not be performed while means of protection are removed unless effective compensatory measures are in place.

Provision must be made to prevent falls – not only from the prefabricated tower scaffold, but also from the adjacent structure.

Bibliography

Standards publications

For dated references, only the edition cited applies. For undated references, the latest edition of the referenced document (including any amendments) applies.

BS 8539, *Code of practice for the selection and installation of post-installed anchors in concrete and masonry*

BS EN 1991-1-4, *Eurocode 1: General actions – Part 1-4: Actions on structures – Wind actions*

Other publications

- [1] GREAT BRITAIN. *Work at Height Regulations 2005*. London: The Stationery Office.
- [2] PREFABRICATED ACCESS SUPPLIERS' AND MANUFACTURERS' ASSOCIATION. *Guidance notes and application for a licence to assemble and use a mobile tower on the highway*. PASMA, 2013.
<http://www.pasma.co.uk/info/pavement-licence-guidance> (last accessed on 03 December 2014)
- [3] HEALTH AND SAFETY EXECUTIVE. *Revision of body size criteria in standards – Protecting people who work at height. RR342*. Sudbury: HSE Books, 2005. ISBN 0-7176-6102-4. ¹⁾

Further reading

BS EN 1993-1-1, *Eurocode 3: Design of steel structures – Part 1-1: General rules and rules for buildings*

BS EN 1995-1-1, *Eurocode 5: Design of timber structures – Part 1-1: General rules – Common rules*

PREFABRICATED ACCESS SUPPLIERS' AND MANUFACTURERS' ASSOCIATION. *Operator's Code of Practice*. PASMA, 2009.

¹⁾ Available to download at <http://www.hse.gov.uk/research/rrpdf/rr342.pdf> (last accessed on 03 December 2014)

British Standards Institution (BSI)

BSI is the national body responsible for preparing British Standards and other standards-related publications, information and services.

BSI is incorporated by Royal Charter. British Standards and other standardization products are published by BSI Standards Limited.

About us

We bring together business, industry, government, consumers, innovators and others to shape their combined experience and expertise into standards-based solutions.

The knowledge embodied in our standards has been carefully assembled in a dependable format and refined through our open consultation process. Organizations of all sizes and across all sectors choose standards to help them achieve their goals.

Information on standards

We can provide you with the knowledge that your organization needs to succeed. Find out more about British Standards by visiting our website at bsigroup.com/standards or contacting our Customer Services team or Knowledge Centre.

Buying standards

You can buy and download PDF versions of BSI publications, including British and adopted European and international standards, through our website at bsigroup.com/shop, where hard copies can also be purchased.

If you need international and foreign standards from other Standards Development Organizations, hard copies can be ordered from our Customer Services team.

Subscriptions

Our range of subscription services are designed to make using standards easier for you. For further information on our subscription products go to bsigroup.com/subscriptions.

With **British Standards Online (BSOL)** you'll have instant access to over 55,000 British and adopted European and international standards from your desktop. It's available 24/7 and is refreshed daily so you'll always be up to date.

You can keep in touch with standards developments and receive substantial discounts on the purchase price of standards, both in single copy and subscription format, by becoming a **BSI Subscribing Member**.

PLUS is an updating service exclusive to BSI Subscribing Members. You will automatically receive the latest hard copy of your standards when they're revised or replaced.

To find out more about becoming a BSI Subscribing Member and the benefits of membership, please visit bsigroup.com/shop.

With a **Multi-User Network Licence (MUNL)** you are able to host standards publications on your intranet. Licences can cover as few or as many users as you wish. With updates supplied as soon as they're available, you can be sure your documentation is current. For further information, email bsmusales@bsigroup.com.

BSI Group Headquarters

389 Chiswick High Road London W4 4AL UK

Revisions

Our British Standards and other publications are updated by amendment or revision.

We continually improve the quality of our products and services to benefit your business. If you find an inaccuracy or ambiguity within a British Standard or other BSI publication please inform the Knowledge Centre.

Copyright

All the data, software and documentation set out in all British Standards and other BSI publications are the property of and copyrighted by BSI, or some person or entity that owns copyright in the information used (such as the international standardization bodies) and has formally licensed such information to BSI for commercial publication and use. Except as permitted under the Copyright, Designs and Patents Act 1988 no extract may be reproduced, stored in a retrieval system or transmitted in any form or by any means – electronic, photocopying, recording or otherwise – without prior written permission from BSI. Details and advice can be obtained from the Copyright & Licensing Department.

Useful Contacts:

Customer Services

Tel: +44 845 086 9001

Email (orders): orders@bsigroup.com

Email (enquiries): cservices@bsigroup.com

Subscriptions

Tel: +44 845 086 9001

Email: subscriptions@bsigroup.com

Knowledge Centre

Tel: +44 20 8996 7004

Email: knowledgecentre@bsigroup.com

Copyright & Licensing

Tel: +44 20 8996 7070

Email: copyright@bsigroup.com



...making excellence a habit.™