

Fans for general purposes —

Part 8: Vocabulary and definition of categories

ICS 01.040.23; 23.120

National foreword

This British Standard reproduces verbatim ISO 13349:1999 and implements it as the UK national standard.

The UK participation in its preparation was entrusted to Technical Committee MCE/17, Industrial fans, which has the responsibility to:

- aid enquirers to understand the text;
- present to the responsible international/European committee any enquiries on the interpretation, or proposals for change, and keep the UK interests informed;
- monitor related international and European developments and promulgate them in the UK.

A list of organizations represented on this committee can be obtained on request to its secretary.

Cross-references

The British Standards which implement international publications referred to in this document may be found in the BSI Standards Catalogue under the section entitled "International Standards Correspondence Index", or by using the "Find" facility of the BSI Standards Electronic Catalogue.

A British Standard does not purport to include all the necessary provisions of a contract. Users of British Standards are responsible for their correct application.

Compliance with a British Standard does not of itself confer immunity from legal obligations.

Summary of pages

This document comprises a front cover, an inside front cover, the ISO title page, pages ii and iii, a blank page, pages 1 to 37 and a back cover.

The BSI copyright notice displayed in this document indicates when the document was last issued.

Amendments issued since publication

Amd. No.	Date	Comments

This British Standard, having been prepared under the direction of the Engineering Sector Committee, was published under the authority of the Standards Committee and comes into effect on 15 November 1999

© BSI 11-1999

ISBN 0 580 35416 4

INTERNATIONAL STANDARD

ISO
13349

First edition
1999-10-01

Industrial fans — Vocabulary and definitions of categories

Ventilateurs industriels — Vocabulaire et définitions des catégories



Foreword

ISO (the International Organization for Standardization) is a worldwide federation of national standards bodies (ISO member bodies). The work of preparing International Standards is normally carried out through ISO technical committees. Each member body interested in a subject for which a technical committee has been established has the right to be represented on that committee. International organizations, governmental and non-governmental, in liaison with ISO, also take part in the work. ISO collaborates closely with the International Electrotechnical Commission (IEC) on all matters of electrotechnical standardization.

Draft International Standards adopted by the technical committees are circulated to the member bodies for voting. Publication as an International Standard requires approval by at least 75 % of the member bodies casting a vote.

International Standard ISO 13349 was prepared by Technical Committee ISO/TC 117, *Industrial fans*.

Annex A of this International Standard is for information only.

Introduction

This International Standard reflects the importance of a standardized approach to the terminology of fans.

The need for an International Standard has been evident for some considerable time. To take just one example, the coding of driving arrangements differs from manufacturer to manufacturer. What one currently calls Arrangement 1 may be known by another as Arrangement 3. The confusion for the customer is only too apparent. For similar reasons, it is essential to use standardized nomenclature to identify particular parts of a fan.

Wherever possible, in the interests of international comprehension, this International Standard is in agreement with similar documents produced by Eurovent, AMCA, VDMA (Germany), AFNOR (France) and UNI (Italy). They have, however, been built on where the need for amplification was apparent.

Use of this International Standard will lead to greater understanding among all parts of the air-moving industry. It is hoped that manufacturers, consultants, contractors and users will adopt and refer to this International Standard as soon as possible.

Industrial fans — Vocabulary and definitions of categories

1 Scope

This International Standard provides a vocabulary and defines categories for general purpose industrial fans and their component parts. It is applicable to any fan used for industrial purposes, including the ventilation of buildings and mines, but excluding ceiling, pedestal and similar circulation types of fans such as those commonly used for non-industrial purposes.

2 Normative references

The following standards contain provisions which, through reference in this text, constitute provisions of this International Standard. At the time of publication the editions indicated were valid. All standards are subject to revision, and parties to agreements based on this International Standard are encouraged to investigate the possibility of applying the most recent editions of the standards listed below. Members of IEC and ISO maintain registers of currently valid International Standards.

ISO 5801:1997, *Industrial fans — Performance testing using standardized airways.*

ISO 5802:—¹⁾, *Industrial fans — Performance testing in situ.*

ISO 13350:1999, *Industrial fans — Performance testing of jet fans.*

ISO 13351:1996, *Industrial fans — Dimensions.*

3 Definitions

For the purposes of this International Standard, the following definitions apply.

3.1

fan

rotary-bladed machine which receives mechanical energy and utilizes it by means of one or more impellers fitted with blades to maintain a continuous flow of air or other gas passing through it and whose work per unit mass does not normally exceed 25 kJ/kg

NOTE 1 The term "fan" is taken to mean the fan as supplied without any addition to the inlet or outlet, except where such addition is specified.

NOTE 2 Fans are defined according to their installation category, function, fluid path and operating conditions.

NOTE 3 If the work per unit mass exceeds a value of 25 kJ/kg, the machine is termed a turbocompressor. This means that, for a mean stagnation density through the fan of $1,2 \text{ kg/m}^3$, the fan pressure will not exceed $1,2 \times 25 \text{ kJ/kg}$, i.e. 30 kPa, and the pressure ratio will not exceed 1,30 since atmospheric pressure is approximately 100 kPa.

¹⁾ To be published.

ISO 13349:1999(E)

3.2

air

in this International Standard, an abbreviation for the expression "air or other gas"

3.3

standard air

by convention, air with a density of 1,2 kg/m³

3.4 Fan installation types according to the arrangement of ducting (see figure 1)

3.4.1

installation type A

installation with free inlet and free outlet

[ISO 5801 and ISO 5802]

3.4.2

installation type B

installation with free inlet and ducted outlet

[ISO 5801 and ISO 5802]

3.4.3

installation type C

installation with ducted inlet and free outlet

[ISO 5801 and ISO 5802]

3.4.4

installation type D

installation with ducted inlet and ducted outlet

[ISO 5801 and ISO 5802]

3.5 Types of fan according to their function

3.5.1

ducted fan

fan used for moving air within a duct

NOTE Such a fan may be arranged in an installation of type (B), (C) or (D) (see figures 2, 3 and 5).

3.5.2

partition fan

fan used for moving air from one free space to another separated from the first by a partition having an aperture in which or on which the fan is installed

NOTE Such a fan should be arranged in an installation of type (A) (see figure 6).

3.5.3

jet fan

fan used for producing a jet of air in a space and unconnected to any ducting (see figures 7 and 8)

NOTE The air jet may be used for example for adding momentum to the air within a duct, a tunnel or other space, or for intensifying the heat transfer in a determined zone.

3.6 Fan types according to the fluid path within the impeller

3.6.1

centrifugal fan

fan in which the air enters the impeller with an essentially axial direction and leaves it in a direction perpendicular to this axis (see figure 2)

NOTE 1 The centrifugal fan is also known as a radial-flow fan.

NOTE 2 The impeller may have one or two inlet(s) and may or may not include a shroud and/or a backplate (centreplate) (see figure 14).

NOTE 3 The impeller is defined as "backward-curved or inclined", "radial" or "forward-curved" depending on whether the outward direction of the blade at the periphery is backward, radial or forward relative to the direction of the rotation (see figure 14).

NOTE 4 A centrifugal fan may be of the low, medium or high pressure type, according to the aspect ratio of fan inlet diameter to outside diameter of the impeller. These terms indicate that the pressure generated at a given flowrate is low, medium or high.

NOTE 5 Figure 5 shows a cross-section through a family of impellers having the same inlet diameter. Fans with ratios of fan inlet/outside impeller diameter of greater than approximately 0,63 are considered "low aspect ratio", and lower than approximately 0,4 are considered "high aspect ratio". Medium aspect ratio centrifugal fans are intermediate between these two figures.

NOTE 6 The impeller diameter and the casing scroll radii increase with the pressure range for which the fan is designed.

NOTE 7 These categories will also be affected by the ability to run at the necessary peripheral speed (see 5.2 and table 1).

3.6.2

axial-flow fan

fan in which the air enters and leaves the impeller along essentially cylindrical surfaces coaxial with the fan (see figure 3)

NOTE 1 An axial-flow fan may be of the low, medium or high pressure type according to the aspect ratio of hub diameter to outside impeller diameter. These terms indicate that the pressure generated at a given flowrate is low, medium or high.

NOTE 2 Figure 10 shows a cross-section through a family of impellers having the same outside diameter. Fans with ratios of hub/outside impeller diameter of less than approximately 0,4 are considered "low aspect ratio", and greater than approximately 0,71 are considered "high aspect ratio". Medium aspect ratio axial fans are intermediate between these two figures.

NOTE 3 These categories will also be affected by the ability to run at the necessary peripheral speed.

3.6.2.1

contra-rotating fan

axial-flow fan which has two impellers arranged in series and rotating in opposite directions

3.6.2.2

reversible axial-flow fan

axial-flow fan which is specially designed to rotate in either direction regardless of whether the performance is identical in both directions

3.6.2.3

propeller fan

axial-flow fan having an impeller with a small number of broad blades of uniform material thickness and designed to operate in an orifice

3.6.2.4

plate mounted axial-flow fan

axial-flow fan in which the impeller rotates in an orifice or spigot of relatively short axial length, the impeller blades being of aerofoil section

3.6.2.5

vane axial fan

axial-flow fan suitable for ducted applications which has guide vanes before or after the impeller, or both

3.6.2.6

tube axial fan

axial-flow fan without guide vanes, suitable for ducted applications

3.6.3

mixed-flow fan

fan in which the fluid path through the impeller is intermediate between the centrifugal and axial-flow types (see figures 7 and 11)

3.6.4

cross-flow fan

fan in which the fluid path through the impeller is in a direction essentially at right angles to its axis both entering and leaving the impeller at its periphery (see figure 12)

3.6.5

ring-shaped fan

air moving device for which the circulation of fluid in the toric casing is helicoidal

NOTE The rotation of the impeller, which contains a number of blades, creates a helicoidal trajectory which is intercepted by one or more blades depending on the flowrate. The impeller transfers energy to the fluid (see figure 13).

3.6.6

multi-stage fan

fan having two or more impellers working in series (2-stage fan, 3-stage fan, etc.)

NOTE 1 Multi-stage fans may have guide vanes and/or interconnecting ducts between successive impellers.

NOTE 2 The blades of an impeller may be either of a profiled section (as an aerofoil) or of uniform thickness (see figure 14).

3.6.7

tubular centrifugal fan

fan having a centrifugal impeller used in an inline ducted configuration (see figure 4)

3.6.8

bifurcated fan

fan having an axial, mixed-flow or centrifugal impeller in an inline configuration where the direct-drive motor is separated from the flowing air stream by means of a compartment or tunnel (see figure 25 Bd)

3.7 Types of fan according to operating conditions

3.7.1

general purpose fan

fan suitable for handling air which is nontoxic, not saturated, noncorrosive, nonflammable, free from abrasive particles and within a temperature range from $-20\text{ }^{\circ}\text{C}$ to $+80\text{ }^{\circ}\text{C}$ (maximum temperature $40\text{ }^{\circ}\text{C}$ if the motor and/or the fan bearings are in the air stream)

3.7.2

special purpose fan

fan used for special operating conditions (see 3.7.2.1 to 3.7.2.11)

NOTE 1 A fan may have a combination of special features.

NOTE 2 The operating conditions stated below represent a typical range, but the list is not necessarily complete. Other types having special features to suit specific applications should be agreed between the manufacturer and purchaser.

3.7.2.1

hot gas fan

fan used for handling hot gases continuously

NOTE 1 Special materials shall be incorporated as necessary for the fan which may have a direct or indirect drive.

NOTE 2 The motor on a direct-drive fan may be either in the air stream or separated from it.

NOTE 3 Indirect-drive fans should incorporate a means for cooling belts, bearings or other drive components where necessary (see 5.3.2 for designation).

3.7.2.2**smoke-ventilating fan**

fan suitable for handling hot smoke for a specified time/temperature profile

NOTE 1 Special materials are incorporated as necessary for the fan, which may have a direct or indirect drive.

NOTE 2 The motor may be either in the air stream on a direct-drive fan, or separated from it.

NOTE 3 Indirect-drive fans incorporate a means for cooling belts, bearings or other drive components where necessary (see 5.3.3 for categorization).

3.7.2.3**wet-gas fan**

fan suitable for handling air containing particles of water or any other liquid

3.7.2.4**gas-tight fan**

fan with a suitable sealed casing to match a specified leakage rate at a specified pressure

NOTE Depending upon the leakage specification, this can involve special attention being paid to all services which penetrate the casing, such as inspection means, lubricator fittings and electrical supply, as well as the details of the connecting flanges (see 5.3.4 for categorization).

3.7.2.5**dust fan**

fan suitable for handling dust-laden air, designed to suit the dust being handled

3.7.2.6**conveying fan****transport fan**

fan suitable for the conveying of solids (e.g. wood chips, textile waste, pulverized materials) and dust entrained in the air stream, designed to suit the material being conveyed

NOTE A conveying/transport fan may be of direct or indirect type, depending on whether or not the handled material passes through the impeller.

3.7.2.7**nonclogging fan**

fan having an impeller designed to minimize clogging by virtue of its detailed shape, or by the use of special materials

NOTE The fan may also incorporate other features to allow the use of cleaning sprays and to facilitate the removal of any material.

3.7.2.8**abrasion-resistant fan**

fan designed to minimize abrasion, having parts that are especially subject to wear constructed in suitable abrasion-resistant materials and/or easily replaceable

3.7.2.9**corrosion-resistant fan**

fan constructed in suitable corrosion-resistant materials or suitably treated to minimize corrosion by specified agents

3.7.2.10**spark-resistant fan****ignition-protected fan**

fan with features designed to minimize the risk of sparks or hot spots resulting from contact between moving and stationary parts that may cause the ignition of dust or gases

NOTE No bearings, drive components or electrical devices should be placed in the air or gas stream, unless they are constructed in such a manner that failure of that component cannot ignite the surrounding gas stream (see 5.3.4 for categorization).

3.7.2.11

powered roof ventilator

fan designed for mounting on a roof and having exterior weather protection

3.8 Fan elements

3.8.1

fan inlet

opening, usually circular or rectangular, through which the air first enters the fan casing

NOTE 1 If the fan is provided with an inlet-connecting flange or spigot, the fan inlet dimensions are measured inside this connection. The inlet area is the gross area measured inside this flange, i.e. no deductions are made for blockages such as motors, bearing supports, etc.

NOTE 2 When the inlet area is not clearly defined, it should be agreed between the parties to the contract.

3.8.2

fan outlet

opening, usually circular or rectangular, through which the air finally leaves the fan casing

NOTE 1 If the fan is provided with an outlet connecting flange or spigot, the fan outlet dimensions are measured inside this connection. When the fan is delivered with a diffuser and the performance is quoted with this fitted, the area of the fan outlet is to be taken as equal to the outlet area of the diffuser.

NOTE 2 When the outlet area is not clearly defined, it should be agreed between the parties to the contract.

NOTE 3 For the special requirements of jet fans, see ISO 13350.

3.8.3

impeller tip diameter

maximum diameter measured over the tips of the blades of the impeller (see ISO 13351)

3.8.4

size designation

nominal impeller tip diameter, defined as the impeller tip diameter on which the design of that fan is based

4 Units and symbols

The following primary units and symbols for the parameters listed shall be used.

Parameter	Symbol	Unit
Volume flowrate	q_v	m ³ /s
Fan pressure	p_F	Pa
Power	P	W
Torque		Nm
Gas density	ρ	kg/m ³
Impeller tip speed	u	m/s
Outlet or duct velocity	v	m/s
Rotational frequency	n	r/s
Rotational speed	N	r/min
Dimensions		mm
Moment of inertia		kg·m ²
Stress		Pa
Energy		kJ
Temperature	θ	K
Work per unit mass	y	kJ/kg
Thrust		kN

4.1 Multiples of primary units

The choice of the appropriate multiple or submultiple of an SI unit is governed by convenience. The multiple chosen for a particular application shall be that which will lead to numerical values within a practical range (e.g. kilopascal for pressure, kilowatts for power and megapascal for stress).

4.2 Units of time

The second is the SI base unit of time, although outside SI the minute has been recognized by CIPM as necessary to retain for use because of its practical importance. Manufacturers may, therefore, continue with the use of r/min for rotational speed.

4.3 Temperature of air/gas

The kelvin is the SI base unit of thermodynamic temperature and is preferred for most scientific and technological purposes. The degree Celsius ($^{\circ}\text{C}$) is acceptable for practical applications.

5 Fan categories

5.1 General

Fans may be categorized according to:

- a) suitability for the fan pressure;
- b) suitability of construction (including features required for smoke ventilation, gas tightness and ignition protection);
- c) driving arrangement;
- d) inlet and outlet conditions;
- e) method of fan control;
- f) rotation and position of parts;
- g) characteristic dimensions.

Examples of the use of the definitions and categories to identify a fan in a specification are given in annex A.

5.2 Suitability for the fan pressure

A fan may also be defined as being low, medium or high pressure, according to the level of work per unit mass, and whether the influence of compressibility of the air or gas being handled has to be taken into account. For a detailed account of these considerations, refer to ISO 5801.

A low-pressure fan is then defined as having a pressure ratio less than 1,02 and a reference Mach No. of less than 0,15. This corresponds to a pressure rise of less than 2 kPa when handling standard air.

A medium-pressure fan is defined as having a pressure ratio greater than 1,02 and less than 1,1. The reference Mach No. shall be less than 0,15. This corresponds to a pressure rise of 2 kPa to 10 kPa.

A high-pressure fan is defined as having a pressure ratio and pressure rise greater than the above.

5.2.1 Work per unit mass

A convention is used for all industrial fans except jet fans (see ISO 13350), denoting the work per unit mass as the quotient of air power and mass flowrate. The fan pressure is approximately equal to the product of work per unit mass and the mean stagnation density of the fluid within the fan.

5.2.2 Fan categories

Depending on its peripheral speed, a fan impeller will develop more or less pressure. This International Standard defines a range of "fan categories" where the fan pressure at maximum efficiency and maximum rotational speed is not less than the value given in table 1. In any event, this defined fan pressure shall not exceed 95 % of the maximum pressure developed by the fan at its maximum speed.

5.2.3 Changes in air density

These categories shall also be used to indicate whether or not the change in air density within the fan shall be considered. For a low-pressure fan this change may be neglected. For a high-pressure fan, this change shall not be neglected, whereas for a medium-pressure fan, it may or may not be neglected depending on the desired accuracy. Detailed mechanical design and construction of the rotational elements will be determined by the peripheral speed and, therefore, the pressure for which the fan is specified.

Table 1 — Categorization of fan according to level of work per unit mass

Fan description	Code	Work per unit mass	"Maximum" fan pressure (for standard air)	Category
		kJ/kg	kPa	
Low pressure	L	> 0 and ≤ 0,6	> 0 and ≤ 0,7	0
		> 0,6 and ≤ 0,83	> 0,7 and ≤ 1	1
		> 0,83 and ≤ 1,33	> 1 and ≤ 1,6	2
		> 1,33 and ≤ 1,67	> 1,6 and ≤ 2,0	3
Medium pressure	M	> 1,67 and ≤ 3	> 2,0 and ≤ 3,6	4
		> 3 and ≤ 5,25	> 3,6 and ≤ 6,3	5
		> 5,25 and ≤ 8,33	> 6,3 and ≤ 10	6
High pressure	H	> 8,33 and ≤ 13,33	> 10 and ≤ 16	7
		> 13,33 and ≤ 18,67	> 16,0 and ≤ 22,4	8
		> 18,67 and ≤ 25	> 22,4 and ≤ 30	9
Turbocompressors		> 25	> 30	

5.3 Suitability of construction

5.3.1 Categorization according to casing construction

Fans are used for a variety of purposes (see 3.7). The air or gas handled may be clean or contain moisture or solid particles and may be at ambient or other temperature. Connection to its associated ducting can be via flexible elements or alternatively it may be attached directly, such that the casing has to withstand additional loads due to the dead weight of these connections. Where a high or low temperature is present, further loading can result from the effects of expansion or contraction. Casing thickness and/or stiffening are also determined by the ability to withstand the specified fan pressure and dynamic loads and by the need for a margin to counter the effects of any erosion or corrosion. For all these and other reasons, different methods of casing construction and different casing thicknesses are appropriate to the application.

The categorization in table 2 reflects current practice and shall be used only to assist specification. It in no way indicates any form of grading. Category 1 is as valid for clean air ventilation as Category 3 is preferred for heavy industrial requirements.

Table 2 — Categorization according to method of casing construction

Category	Typical casing features	Usage	Casing thickness
1	Lockformed, spot welded or screwed construction. Cradle or angle frame mounting	— Light HVAC Clean air	$< 0,0025 D$
2	Lockformed, seam welded or continuously welded construction. Semi-universal design with bolted on side-plates	— Heavy HVAC — Light industrial Light dust or moisture	$> 0,0025 D$
3	Fully welded fixed discharge	— Heavy industrial • Dirty air containing moisture and/or solids, or • High pressure, or • High power	$> 0,00333 D$
NOTE D is the nominal impeller diameter, in millimetres.			

5.3.2 Designation for hot-gas fan

Where a fan is suitable for continuous operation up to a stated maximum temperature (hot gas fan, see 3.7.2.1), this should be indicated on the conventional fan rating plate itself.

The following designation shall be used:

T, followed by the maximum temperature, in degrees Celsius, for continuous operation.

EXAMPLE T/500 denotes a fan rated for a maximum continuous temperature of 500 °C.

5.3.3 Designation and recommended categorization for smoke-ventilating fans (see 3.7.2.2)

If the fan is also, or only, capable of short-term operation at a high temperature, this information shall be clearly stated on a separate label.

The following designation shall be used:

HT, followed by temperature in degrees Celsius and time, at the stated temperature, in hours or decimals of an hour.

EXAMPLE HT/300/0,5, denotes "a high-temperature fan rated for operation at 300 °C for 0,5 h (i.e. 30 min)".

The recommended categories for smoke-ventilating fan are given in table 3.

Table 3 — Recommended categorization of smoke-ventilating fans

Temperature category	Coding	Maximum air/gas temperature °C	Minimum operating time h
A	HT/150/5,0	150	5,0
B	HT/200/2,0	200	2,0
C	HT/250/1,0	250	1,0
D	HT/300/1,0	300	1,0
E	HT/400/2,0	400	2,0
F	HT/600/1,5	600	1,5
G	HT/850/1,0	850	1,0

5.3.4 Categorization for gas-tight fans (see 3.7.2.4)

Gas-tight fans shall be categorized in accordance with table 4. The amount of leakage is dependent on the pressure within the fan casing and the time for which this must be maintained. The leakage rate is obtained by blocking off the fan inlet and outlet and 'pumping up' or extracting the casing using an auxiliary test fan. The change test pressure shall be measured by a manometer as a function of time. The leakage rate is then determined from the flow of the auxiliary test fan or other pressure sources. This leakage shall be less than the value calculated from the formula appropriate to the category.

NOTE Normally the fan is stationary during this test. However if the correct functioning of the shaft seal is dependent on fan rotation, then the test shall be carried out with the impeller removed and the remainder of the fan running.

Categories A to D match the established classes of allowable ductwork leakage rate used in the air-conditioning industry. Category E is often specified for systems handling toxic fumes, whilst Categories F and G relate to nuclear and defence equipment specifications respectively.

Table 4 — Categorization of gas-tight fans — Leakage as a function of test pressure

Leakage category	Maximum test pressure kPa	Time at maximum pressure min	Acceptance criteria/ maximum leakage rate
A	0,5	15	$0,027 \times p^{0,65}$
B	1	15	$0,009 \times p^{0,65}$
C	2	15	$0,003 \times p^{0,65}$
D	2,5	15	$0,001 \times p^{0,65}$
E	2,5	15	$0,0005 \times p^{0,65}$
F	3	60	Fall in $p < 500$ Pa
G	10,5	15	No detectable leaks

NOTE Leakage rates are in litres per second per square metre of casing wetted area and p is the test pressure in pascals.

5.3.5 Categorization for ignition-protected fans (see 3.7.2.10)

5.3.5.1 General considerations

Fans may sometimes handle potentially explosive or flammable particles, fumes or vapours. These applications require careful consideration of all system components to ensure the safe handling of the gas stream. This International Standard deals only with the fan unit installed in that system and contains guidelines which are to be

used by both the manufacturer and user as a means of establishing general methods of construction. The exact method of construction and choice of alloys is the responsibility of the manufacturer; however, the customer shall inform him of the potential hazard and the degree of protection required.

The use of this categorization cannot guarantee absolute safety. Ignition-protected construction does not protect against ignition of explosive gases or dust caused by catastrophic failure causing complete fan breakdown, or from foreign objects or material that may be present in a system and moved by the air stream.

This categorization applies to ferrous and non-ferrous metals. The potential questions which may be associated with fans constructed of fibre-reinforced plastics, PVC or any other plastics compound are not addressed. The types of ignition-protected fan shall be categorized as given in table 5.

NOTE The categorization shown in table 5 is based on industry practice. For further information refer to the EUROVENT document "Ignition-protected fan".

Table 5 — Categorization of ignition-protected fans

Type	Construction
A	All parts of the fan in contact with the air or gas being handled shall be made of metals that do not produce sparks or hot spots when striking or rubbing against each other, which may ignite the gases, liquid or dust that may be present. Steps must also be taken to ensure that the impeller bearings and shaft are adequately attached and/or restrained to prevent a lateral or axial shift in these components.
B	The fan shall be designed so that the parts of the fan that are most likely to touch in case of fault are made of metals that do not produce sparks or hot spots when striking or rubbing against each other. This could in an axial fan be obtained by e.g. aluminium impeller blades and an aluminium lining to the casing, other parts such as the hub, shaft etc. may be a ferrous material. Steps shall also be taken to ensure that the impeller, bearings and shaft are adequately attached and/or restrained to prevent a lateral or axial shift in these components.
C	The fan shall be so constructed that a shift of the impeller or shaft will not permit two parts of the fan to rub or strike, which might produce sparks.
NOTE Where low-risk materials are not used (e.g. some auxiliary mine fans) all clearances between rotating and static parts shall be not less than 5 mm.	

5.3.5.2 Additional requirements

5.3.5.2.1 It is not sufficient that sparks or hot spots do not occur between clean rubbing surfaces. Corroded surfaces shall also be ignition-protected and no paint shall be used which, in combination with one of the metals, can give rise to sparks (iron oxide paint with aluminium could represent a hazard).

Flying flakes of corrosion or paint shall be avoided. Easily flammable metals such as magnesium or aluminium alloys containing more than 5 % magnesium should be avoided.

The metal pairings employed shall be chosen on the basis of ignition temperature and energy of the gases or dust to be expected. In many cases — but not all — a reasonable degree of safety may be obtained with the following pairings:

Aluminium — Aluminium

Steel — Naval brass or leaded brass

NOTE 1 The most effective ignition protection is to prevent buildup of dangerous gas concentrations or dust quantities.

NOTE 2 The use of aluminium or aluminium alloys in the presence of steel which may be exposed to oxidation requires special consideration. Experiments by mine research establishments throughout the world have shown that aluminium impellers rubbing on rust may cause high intensity sparking.

5.3.5.2.2 Electrolytic corrosion between different alloys should be avoided, as it may cause deformation, loosening of linings, etc. and lead to increased hazard, e.g. copper lining on a galvanized surface.

5.3.5.2.3 No bearings, drive components or electrical devices shall be placed in the air or gas stream unless they are constructed or enclosed in such a manner that failure of that component cannot ignite the surrounding gas stream.

5.3.5.2.4 The user shall electrically earth all fan parts.

5.3.5.2.5 Regular inspections and cleaning of fans and ducts shall be carried out by the user, as bearing life, corrosion effects, vibrations, etc. may considerably influence the life and safety of the fan.

5.3.5.2.6 Monitoring of vibration is recommended.

5.4 Drive arrangements

The six most commonly used types of drive are as follows:

- a) **Direct drive from the shaft of the motor or other prime mover.** The impeller is fixed to the shaft extension.
- b) **Drive through an inline direct coupling.** The drive shaft and the impeller shaft are each fixed on a part of the in-line direct coupling and rotate at the same speed.
- c) **Drive through an inline slipping coupling.** The drive shaft is fixed to the primary part of the coupling and the impeller shaft to the secondary part of the coupling enabling them to rotate at different speeds, the relative difference of which (i.e. the slip) depends upon the speed, the torque to be transmitted and when appropriate the degree of control applied to the coupling.
- d) **Drive through a gearbox.** The drive shaft and the impeller shaft are not necessarily coaxial; they may be parallel or at an angle, their speeds being in one or more given ratio(s).
- e) **Belt drive.** The drive shaft and the impeller shaft are not in-line but parallel, the drive between the two being by means of flat, toothed or vee belts (or belts of some other section) and suitable pulleys. Their speeds are in a given ratio subject to a small amount of slip except in the case of the toothed belt.
- f) **Direct drive with inset motor.** The motor is set inside the fan casing.

Fans shall be classified according to the drive arrangements of the fan, especially as far as direct and belt driven units are concerned. These are shown in table 6 for centrifugal units and table 7 for axial units.

Table 6 — Drive arrangements for centrifugal fans

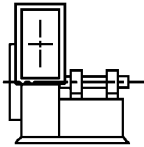
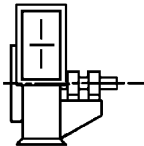
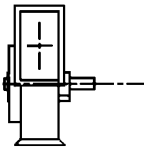
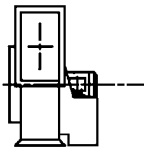
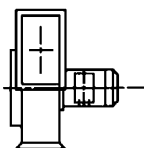
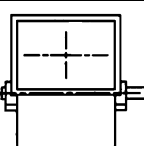
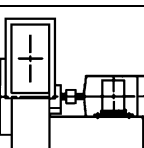
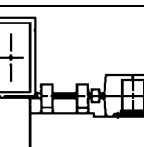
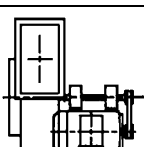
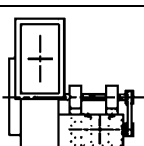
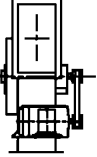
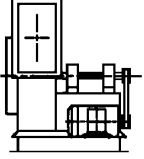
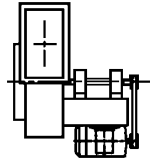
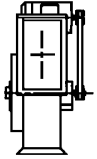
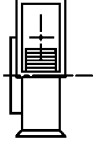
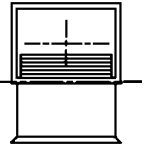
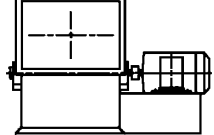
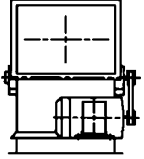
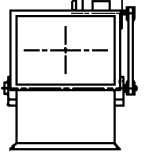
Arrangement No.	Description	Motor position (see figure 22)	Outline drawing
1	Single-inlet fan for belt drive. Impeller overhung on shaft running in 2 plummer block bearings supported by a pedestal.	—	
2	Single-inlet fan for belt drive. Impeller overhung on shaft running in bearings supported by a bracket attached to the fan casing.	—	
3	Single-inlet fan for belt drive. Impeller mounted on shaft running in bearings on each side of casing and supported by the fan casing.	—	
4	Single-inlet fan for direct drive. Impeller overhung on motor shaft. No bearings on fan. Motor supported by base.	—	
5	Single-inlet fan for direct drive. Impeller overhung on motor shaft. No bearings on fan. Motor attached to casing side by its flanged end-shield.	—	
6	Double-inlet fan for belt drive. Impeller mounted on shaft running in bearings on each side of casing and supported by the fan casing.	—	
7	Single-inlet fan for coupling drive. Generally as arrangement 3 but with a base for the driving motor.	—	
8	Single-inlet fan for coupling drive. Generally as arrangement 1 plus an extended base for the driving motor.	—	
9	Single-inlet fan for coupling drive. Generally as arrangement 1 but with the motor mounted on the outside of the bearing pedestal.	W or Z	
10	Single-inlet fan for belt drive. Generally as arrangement 1 but with the drive motor inside the bearing pedestal.	—	

Table 6 (end)

Arrangement No.	Description	Motor position (see figure 22)	Outline drawing
11	Single-inlet fan for belt drive. Generally as arrangement 3 but with the fan and motor supported by a common base frame.	W or Z (very rarely X or Y)	
12	Single-inlet fan for belt drive. Generally as arrangement 1 but with the fan and motor supported by a common base frame.	W or Z (very rarely X or Y)	
13	Single-inlet fan for belt drive. Generally as arrangement 1 but with the motor fixed underneath the bearing pedestal.	—	
14	Single-inlet fan for belt drive. Generally as arrangement 3 but with the motor supported by the fan scroll.	—	
15	Single-inlet fan for direct drive. Driving motor in-set within impeller and fan casing.	—	
16	Double-inlet fan for direct drive. Driving motor in-set within impeller and fan casing.	—	
17	Double-inlet fan for coupling drive. Generally as arrangement 6 but with a base for the driving motor.	—	
18	Double-inlet fan for belt drive. Generally as arrangement 6 but with a fan and motor supported by common base frame.	W or Z (very rarely X or Y)	
19	Double-inlet fan for belt drive. Generally as arrangement 6 but with the motor supported by the fan scroll.	—	

NOTE Arrangements 1, 3, 6, 7, 8 and 17 may also be provided with the bearings mounted on pedestals for base set independent of the fan housing.

Table 7 — Drive arrangements for axial-flow fans

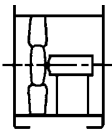
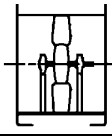
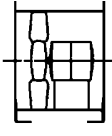
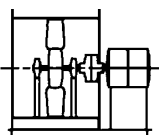
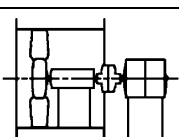
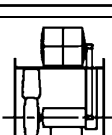
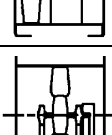
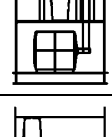
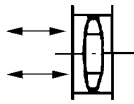
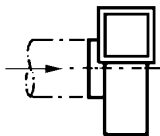
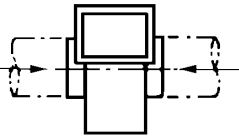
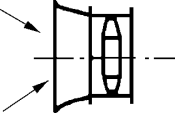
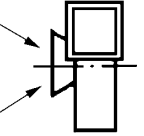
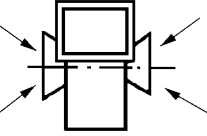
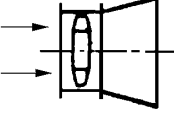
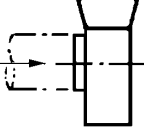
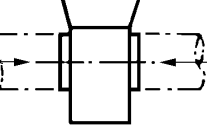
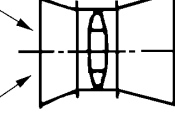
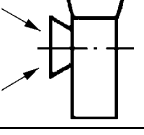
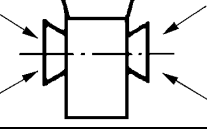
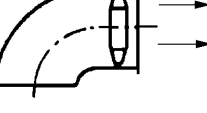
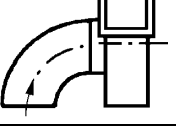
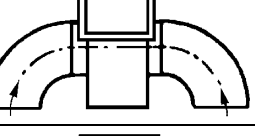

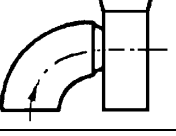
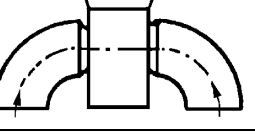
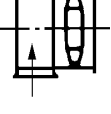
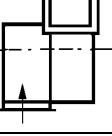
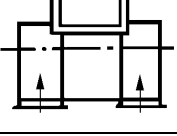
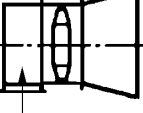
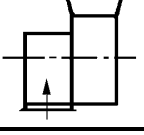
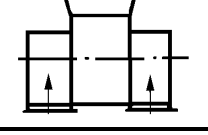
Arrangement No.	Description	Motor position (see figure 22)	Outline drawing
1	For belt drive. Impeller overhung on shaft running in 2 bearings, suitably supported.	—	
3	For belt drive. Impeller overhung on shaft running between bearings and supported by fan housing.	—	
4	For direct drive. Impeller overhung on driving motor shaft. No bearings on fan. Driving motor base-mounted or integrally direct-connected.	—	
7	For coupling drive. Generally as arrangement 3 but with a base for the driving motor.	—	
8	For coupling drive. Generally as arrangement 1 plus an extended base for the driving motor.	—	
9	For belt drive. Generally as arrangement 1 but with a driving motor outside and supported by the fan casing.	See Fig. 19 —	
11	For belt drive. Generally as arrangement 3 but with fan and driving motor outside and supported by a common base frame	W or Z (very rarely X or Y)	
12	For belt drive. Generally as arrangement 1 plus an extended base for the driving motor.	W or Z (very rarely X or Y)	

Table 8 — Inlet/outlet ancillaries for fans

Subcode	Description	Outline drawing		
		Axial-flow fans	Single-inlet centrifugal fans	Double-inlet centrifugal fans
U	Fan with inlet and outlet openings immediately adjacent to the casing.			
E	Fan with a cone or bellmouth inlet and with the outlet opening immediately adjacent.			
D	Fan with a diffuser on the fan outlet and with the inlet opening immediately adjacent.			
ED	Fan with a cone or bellmouth inlet on the inlet side and a diffuser on the outlet.			
B	Fan with a bend on the inlet side and the outlet side immediately adjacent.			
BD	Fan with a bend on the inlet side and a diffuser on the outlet.			
S	Fan with side box entry to the inlet and outlet opening immediately adjacent.			
SD	Fan with side box entry to the inlet and diffuser on the fan outlet.			

5.5 Inlet and outlet conditions

The direction or condition of the flow into or out of the fan, may be modified by the addition of ancillaries. These are identified by alphabetical subcodes (see table 8).

5.6 Method of fan control

Various methods of fan control are commonly used in order to modify fan performance:

- a) **Variable speed control.** Speed can be varied either continuously or in steps by a variable-speed motor, slipping coupling, gearbox or other means.

- b) **Damper control.** The fan performance is controlled by means of a damper, either on the inlet or on the outlet, creating an additional variable system resistance.
- c) **Vane control.** Vanes mounted at the fan inlet can be adjusted in order to change the fan performance by controlling the swirl at the fan inlet.
- d) **Blade pitch control**
 - 1) Variable blade pitch control (normally only for axial-flow fans). The blade angle of the impeller can be varied whilst the impeller is rotating, all blades being simultaneously varied by one operation.
 - 2) Adjustable pitch

If the blade angle of the impeller can be altered only when the impeller is stationary, this method of control is termed "adjustable pitch".

NOTE When the blade angle cannot be changed, it is said that the fan has a "fixed pitch".

5.7 Designation of direction of rotation and position of parts of the fan assembly

The conventions detailed below shall be used for designating the direction of rotation of the fan and the position of some of its parts.

5.7.1 Direction of rotation

By convention, the direction of rotation is determined from the side opposite the inlet, no matter what the actual position of the drive (see figures 15, 16 and 17). The direction of rotation is designated clockwise (right-hand, symbol RD) or anticlockwise (left-hand, symbol LG) according to the direction seen when viewed along the axis of the fan from the side opposite the inlet.

NOTE 1 For a contra-rotating fan, rotation of the first stage shall determine the direction of rotation.

NOTE 2 For a double-inlet centrifugal fan and a cross-flow fan, the direction of rotation is determined when viewed from the driving side.

NOTE 3 Clockwise rotation of the fan may entail anticlockwise rotation of the driving motor. Rotational direction of motor is always defined looking upon the driving end of the motor shaft.

5.7.2 Outlet position of a centrifugal fan

The angular positions of the outlet of a fan shall be defined in relation to an origin taken as a straight line perpendicular to the mounting base towards the axis of rotation (see figures 18 and 19).

The outlet position of a centrifugal fan is designated by the symbol for the direction of rotation, i.e. LG or RD, followed by the angle, in degrees, between the origin and the axis of discharge, the angle being measured in the direction of rotation as defined in 5.7.1 (e.g. LG 135 or RD 90) (see figures 15, 18 and 19).

5.7.3 Position of component parts of a centrifugal fan with volute casing

The angular position of a motor, inlet box or bend, inspection door or any other component is designated by the symbol for the direction of rotation (i.e. LG or RD) followed by the angle, in degrees, between the origin as defined in 5.7.2 and the axis of the component part, the angle being measured in the direction of rotation as defined in 5.7.1 (see figure 20).

NOTE Where the fan casing is not provided with feet, the outlet position will be taken as 0°.

5.7.4 Position of component parts of an axial-flow, mixed-flow or other fan with coaxial inlet and outlet

The angular position of a motor, an inlet box or bend, outlet bend, inspection door, terminal box, mounting feet, extended lubricators and axis of the belt drive or gearbox input shaft is defined by the angle in degrees between the origin and the axis of the component measured in a clockwise direction when viewed along the axis of rotation, from the side opposite to the inlet, irrespective of the direction of rotation of the fan (see figure 21).

An exception is a reversible axial-flow fan which is viewed from the driving side. Where the definition of origin given in figure 21 does not apply, an arbitrary origin may be chosen.

5.7.5 Position of motor or other prime mover

5.7.5.1 Plan view position of motor for belt or chain drive

The position of a motor when viewed perpendicular to the fan mounting base shall be denoted by letters W, X, Y, Z as shown in figure 22 and it shall be specified whether the drive is on the inlet side or on the side opposite the inlet.

5.7.5.2 Position of motor in a direct-driven axial-flow, mixed-flow or other fan with coaxial inlet and outlet

The motor position for a direct-driven fan with horizontal or vertical axis shall be designated as shown in figure 23.

5.8 Characteristic dimensions and component parts

5.8.1 Characteristic dimensions

Size designations, inlet and outlet flanges shall be as defined in ISO 13351. The definitions of size designation are given in 3.8.4.

Figures 24 to 27 show the arrangements of typical fans. In each case the fan inlet is identified by “1” whilst the outlet is identified by “2” and the impeller tip diameter by “3”.

5.8.2 Terms for fan component parts

The illustrations (figures 24, 25, 26 and 27) have been chosen as examples to show component parts of fans (table 9 gives the index of fan parts and table 10 lists the preferred terms for fan component parts). Many alternative features and arrangements are possible and the selected illustrations shall not be taken as standard designs for the kinds of fan involved.

Table 9 — Index illustration of fans

Ref.	Fan type	Features
Aa	Centrifugal	Backward curved — indirect drive
Ab		Forward curved — direct drive
Ac		Paddle blades — indirect drive
Ad		Vane control — coupled drive
Ae		Double inlet
Af		Multistage
Ag		Two stages with duct connection (duplex)
Ba	Axial-flow	Long casing — guide vanes — direct drive
Bb		Short casing — direct drive
Bc		Indirect drive
Bd		Shielded motor (bifurcated) — direct drive
Be		Multistage — indirect drive
Bf		Propeller fan
Ca	Mixed-flow	Direct drive
Da	Cross-flow	Direct drive

Table 10 — List of preferred terms for fan components (see figures 24 to 27)

	Component part	A ¹⁾						B ¹⁾						C ¹⁾	D ¹⁾		
		a	b	c	d	e	f	g	a	b	c	d	e	f	g	a	a
10	Impeller	a	b	c	d	e	f	g	a	b	c	d	e	f		a	a
11	Blades	a	b	c		e	f		a	b	c	d	e	f		a	a
12	Blade tip	a	b	c			f										
13	Blade tip								a	b	c	d	e	f		a	
14	Blade inlet edge	a	b	c			f										
15	Blade leading edge								a	b			e	f			
16	Blade trailing edge								a	b			e	f			
17	Blade root								a	b	c	d	e			a	
18	Hub	a	b			e			a	b	c	d	e	f		a	
19	Hub boss	a	b	c		e	f		a	b						a	
20	Hub disc		b						a	b						a	
21	Hub rim								a	b						a	
22	Hub spider			c													
23	Impeller backplate	a	b				f										
24	Impeller centreplate					e											
25	Impeller endplate																a
26	Impeller shroud	a	b			e	f										
27	Impeller intermediate shroud	a															
28	Fan casing	a	b	c	d	e	f	g	a	b	c	d	e			a	a
29	Scroll plate	a	b	c	d	e	f										
30	Cut-off	a		c			f										
31	Extended cut-off		b			e											
32	Casing inlet sideplate	a	b	c	d	e	f	g									
33	Casing backplate	a	b	c	d		f	g									
34	Casing coverplate			c													
35	Inlet flange		b	c	d		f	g	a			d	e			a	
36	Inlet spigot	a															
37	Shaped inlet	a	b			e			a	b						a	
38	Inlet box		b						a								
39	Outlet flange	a		c			f	g	a			d	e			a	
40	Outlet spigot		b			e											
41	Outlet transformer	a															
42	Outlet expander						f		a			e					
43	Outlet reducer			c													
44	Interconnecting duct							g									
45	Centre fairing															a	
46	Upstream centre fairing								a			e				a	
47	Downstream centre fairing								a			e				a	
48	Fairing supports								a			e				a	
49	Guide vanes (a set) (Guide vane)						f					e					
							f					e					
50	Upstream guide vanes (a set) (Upstream guide vane)								a								
									a								
51	Downstream guide vanes (a set) (Downstream guide vane)								a			e				a	
									a			e				a	
52	Casing stiffeners	a															
53	Base angles	a	b	c	d							e					

Table 10 — List of preferred terms for fan components (see figures 24 to 27) (end)

	Component part	A ¹⁾							B ¹⁾							C ¹⁾	D ¹⁾	
		a	b	c	d	e	f	g	a	b	c	d	e	f	g	a	a	
54	Foot or feet					e			a		c						a	a
55	Casing drain			c														
56	Access or inspection door	a		c					a		c							
57	Mounting ring (wall flange)									b								
58	Mounting lugs									b								
59	Diaphragm plate													f				
60	Motor stool		b															
61	Motor bracket										c	d						
62	Motor arms									b				f				
63	Motor supports								a								a	
64	Bearing pedestal	a																
65	Bearing bracket			c										e				
66	Bearing stool				d													
67	Bearing supports					e					c							
68	Baseframe	a		c										e				
69	Anti-vibration mountings			c										e				
70	Combination baseplate				d													
71	Motor or other prime mover		b	c	d		f	g	a	b	c	d	e	f			a	a
72	Bearings	a		c	d	e					c		e					a
73	Shaft	a	b	c	d	e	f		a	b	c	d	e	f			a	a
74	Shaft extension	a	b	c		e			a									
75	Shaft seal		b															
76	Cooling disc (or impeller)	a																
77	Fan pulley			c							c		e					
78	Motor pulley			c							c		e					
79	Drive belt(s)			c							c		e					
80	Coupling				d													
81	Inlet guard	a							a								a	
82	Motor-side guard									b				f				
83	Impeller-side guard									b				f				
84	Shaft guard	a			d													
85	Drive guard			c							c		e					
86	Coupling guard				d													
87	Cooling disc (or cooling impeller) guard	a																
88	Inlet vane control				d													
Dimensions																		
1	Fan inlet	a	b	c	d		f	g	a			d	e				a	a
2	Fan outlet	a	b	c		e	f	g	a	b		d	e				a	a
3	Impeller tip diameter	a	b	c					a	b	c	d	e	f			a	
4	Impeller tip clearance								a	b	c	d	e	f			a	
5	Impeller inlet clearance	a	b	c		e	f											

1) See table 9.

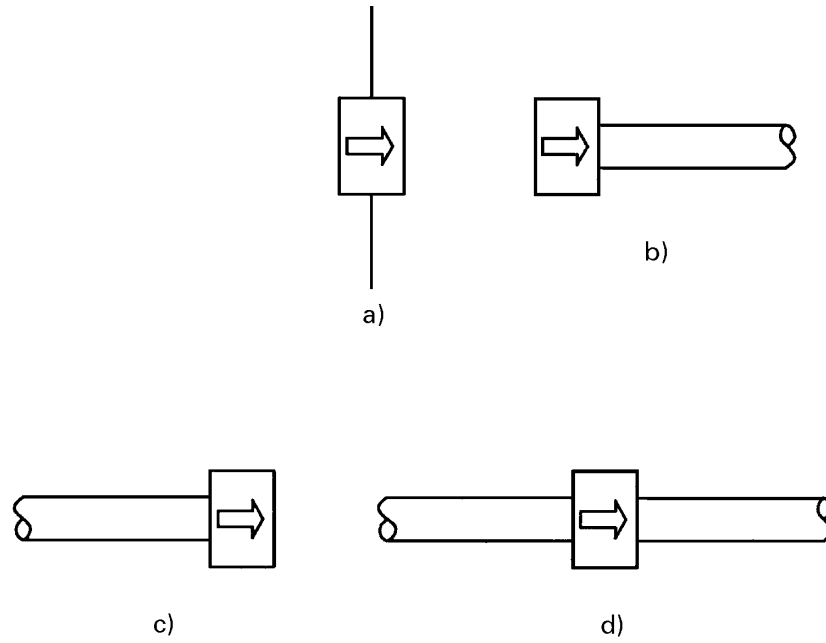
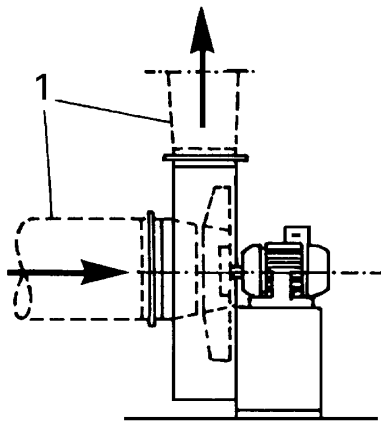


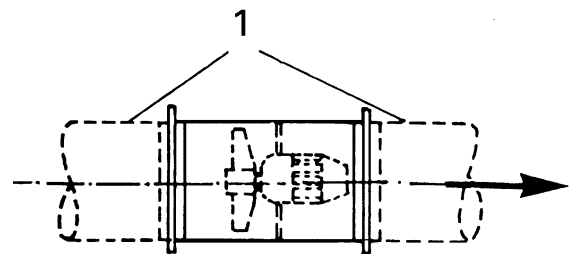
Figure 1 — Installation type



Key

1 Ducts

Figure 2 — Centrifugal fan



Key

1 Ducts

Figure 3 — Axial-flow fan

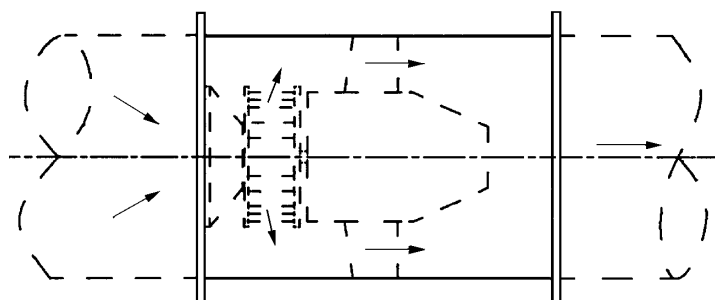


Figure 4 — Tubular centrifugal fan

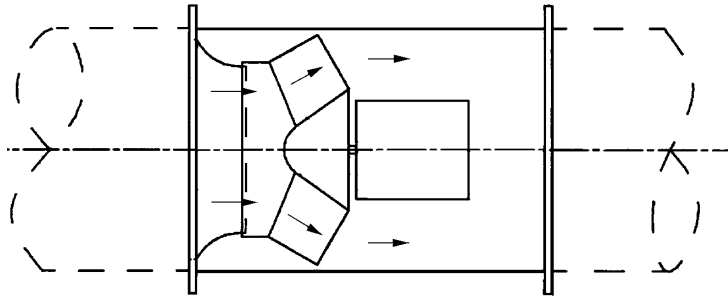


Figure 5 — Mixed-flow fan

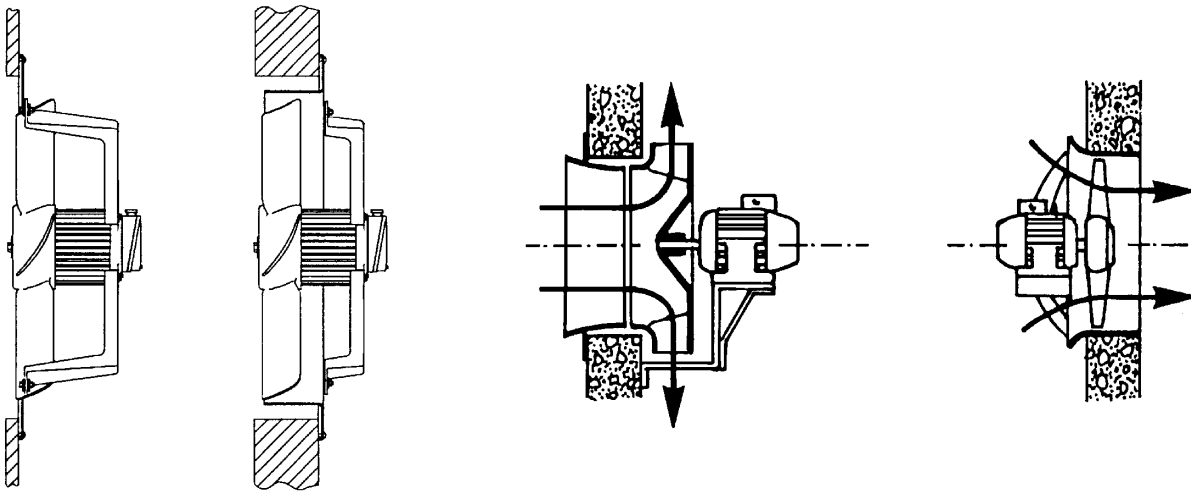


Figure 6 — Partition fans

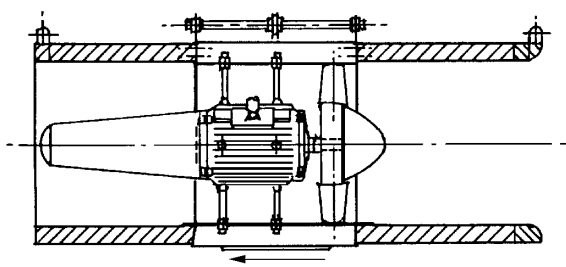


Figure 7 — Jet fan for tunnels

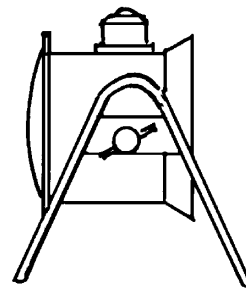


Figure 8 — Jet fan for cooling

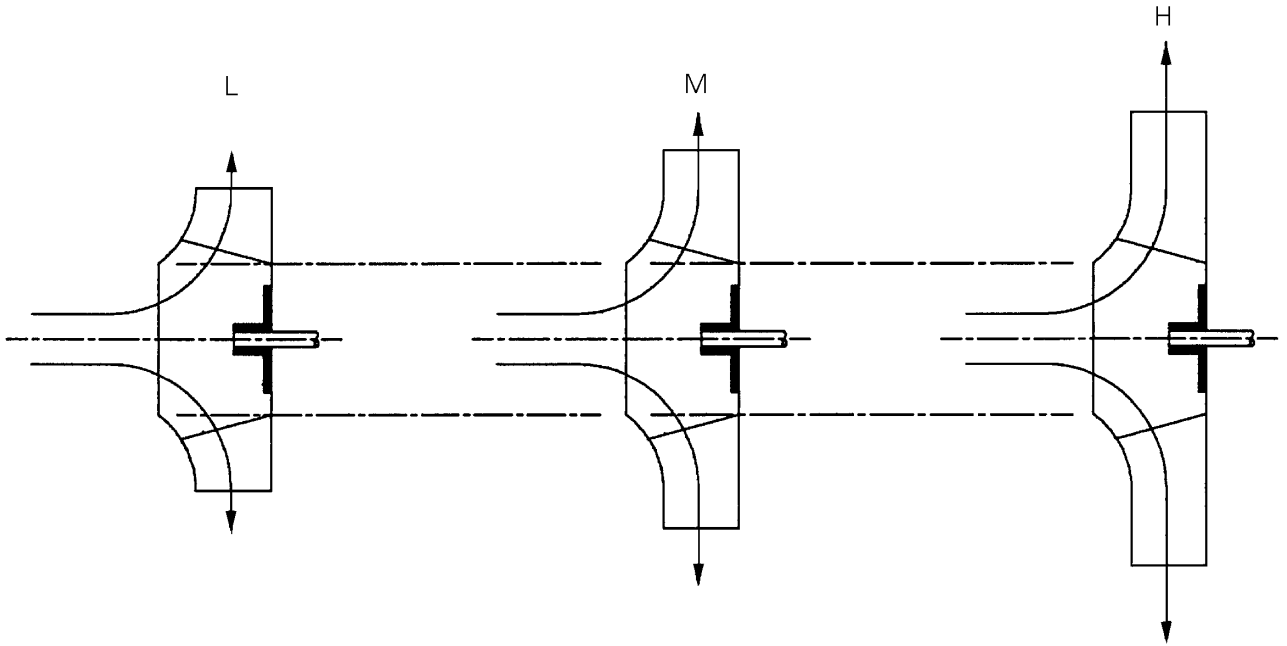


Figure 9 — Impellers of a centrifugal fan

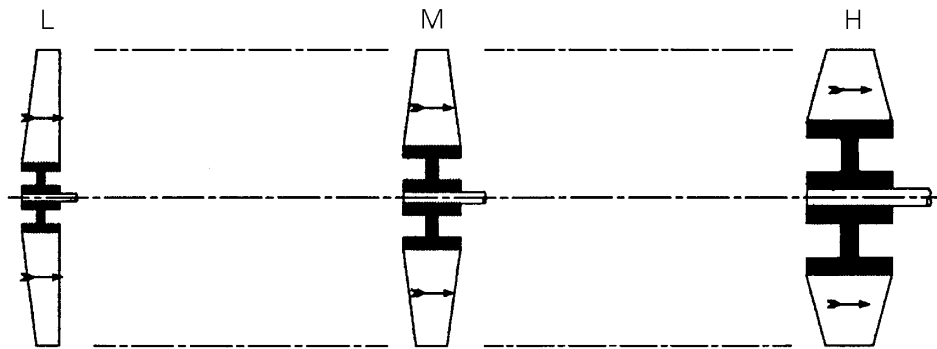


Figure 10 — Impellers of an axial-flow fan

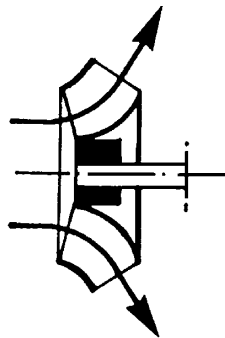


Figure 11 — Impeller of a mixed-flow fan

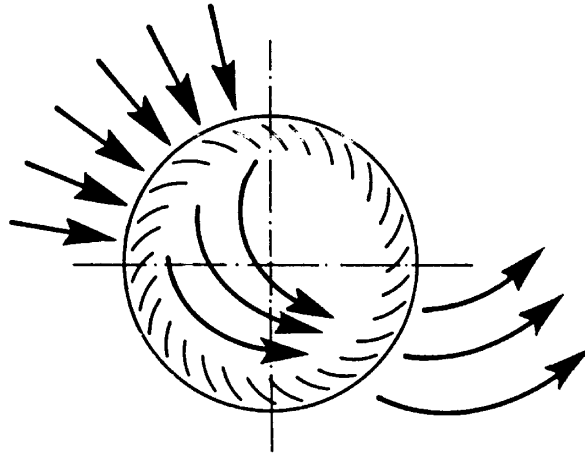
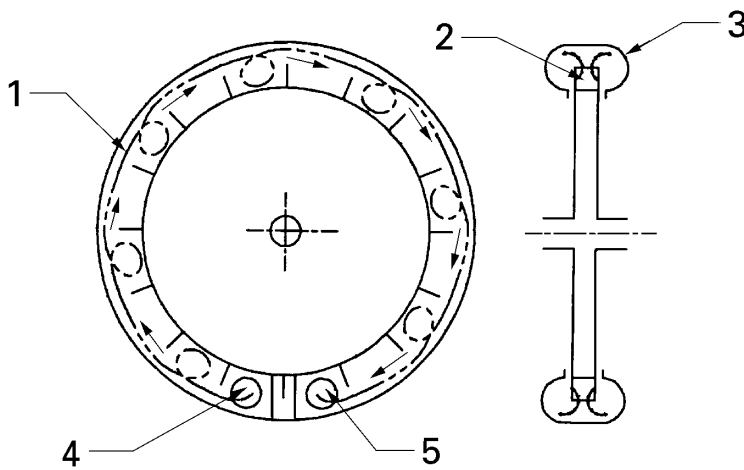


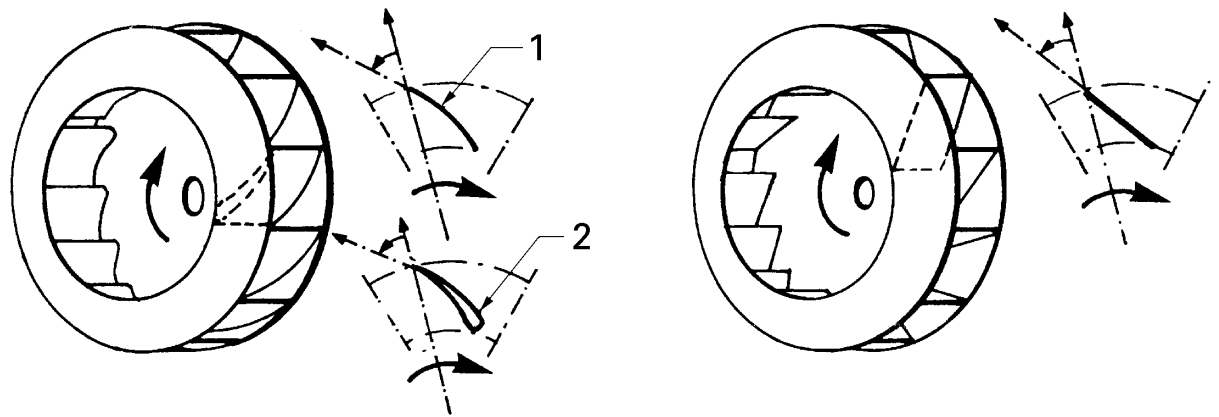
Figure 12 — Impeller of a cross-flow fan



Key

- 1 Fluid
- 2 Blade
- 3 Casing
- 4 Inlet
- 5 Outlet

Figure 13 — Impeller of a ring-shaped fan



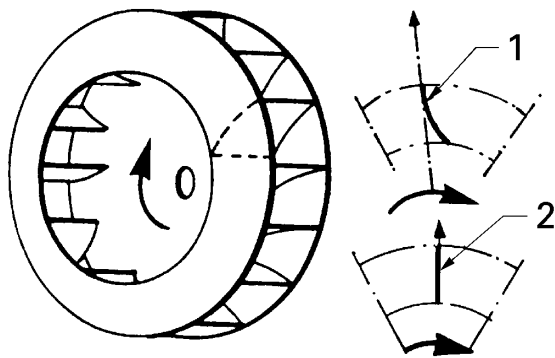
Backward-curved

Backward-inclined

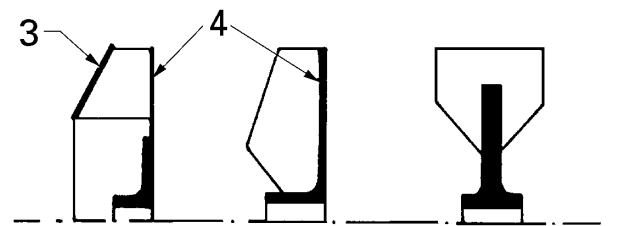
Key

- 1 Uniform thickness
- 2 Aerofoil

a) Backward



Radial-tipped



Shrouded

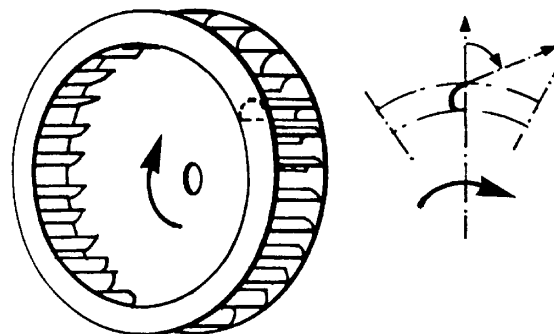
Unshrouded

Paddle blades

Key

- 1 Radial-tipped
- 2 Radial
- 3 Shroud
- 4 Backplate

b) Radial



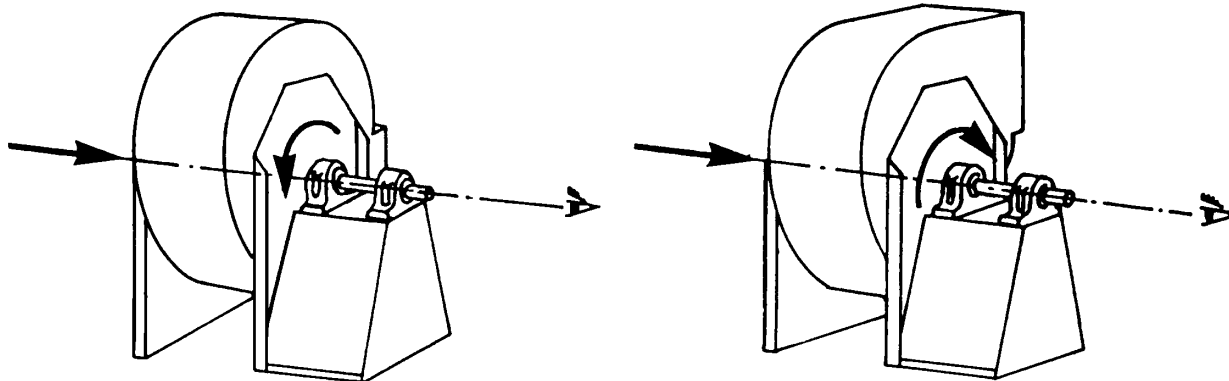
Forward-curved

c) Forward

Figure 14 — Examples of centrifugal impellers

LG: anticlockwise rotation

RD: clockwise rotation

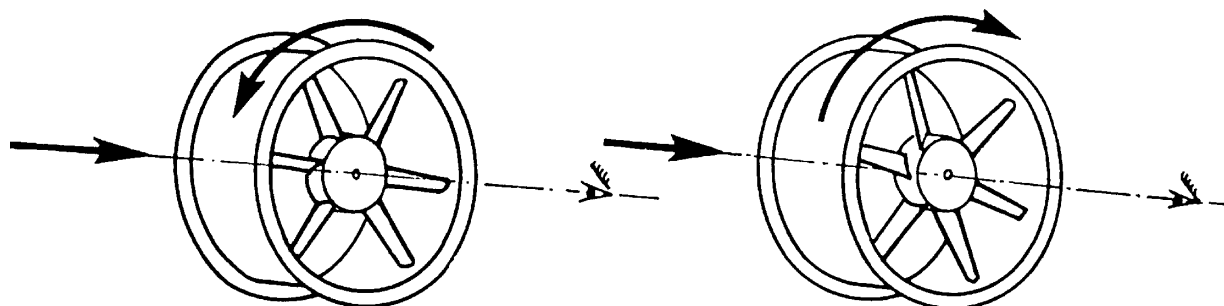


NOTE The rotation of a single-inlet fan shall always be determined from the side opposite the inlet, no matter where the actual location of the drives.

Figure 15 — Direction of rotation of centrifugal fans

LG: anticlockwise rotation

RD: clockwise rotation



NOTE The rotation of an axial-flow fan is determined from the side opposite the inlet.

Figure 16 — Direction of rotation of axial-flow and mixed-flow fans

LG: anticlockwise rotation

RD: clockwise rotation

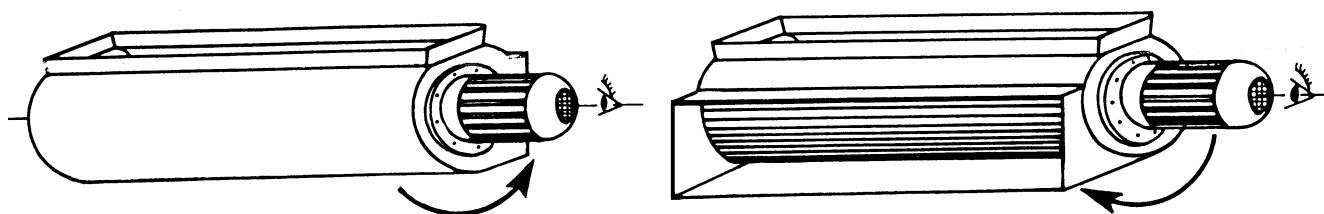
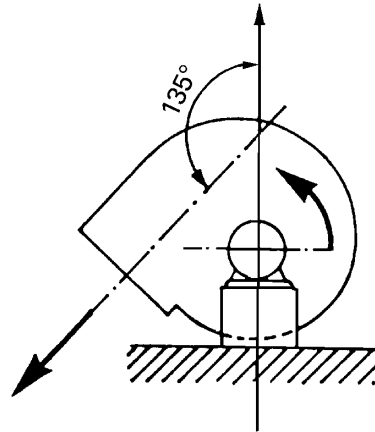


Figure 17 — Direction of rotation of cross-flow fans



EXAMPLE LG 135

Figure 18 — Conventional designation of the outlet position of a centrifugal fan

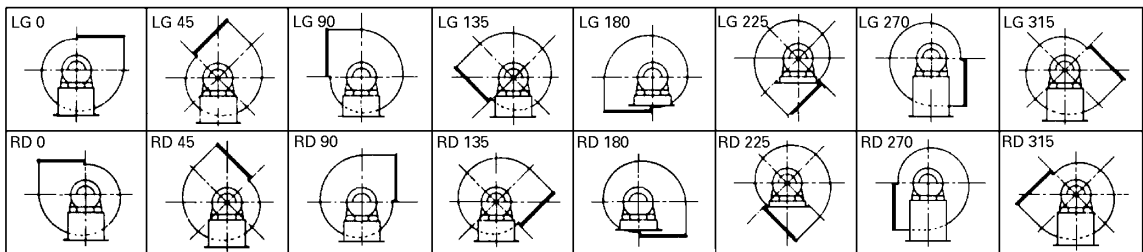
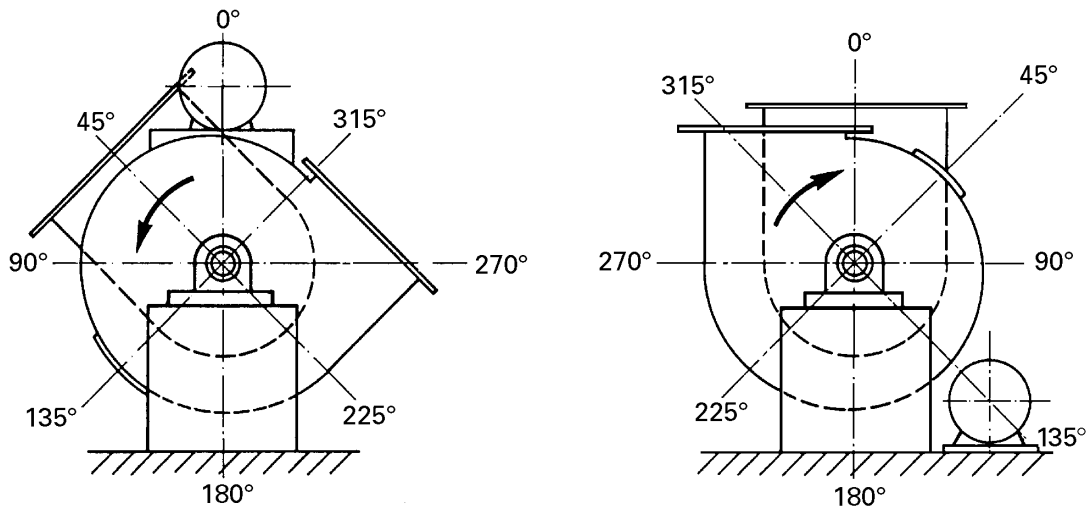


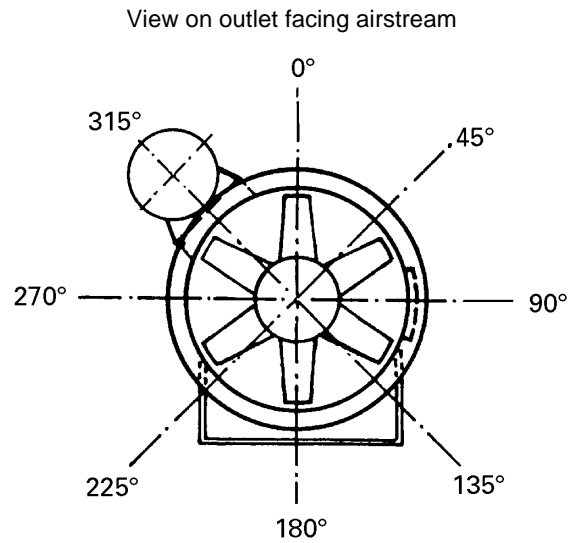
Figure 19 — Recommended positions for the outlet of a centrifugal fan



EXAMPLES
 Outlet: LG 315
 Inspection door: LG 135
 Inlet box: LG 45
 Motor: LG 0

Outlet: RD 0
 Inspection door: RD 45
 Inlet box: RD 0
 Motor: RD 135

Figure 20 — Conventional designation of the angular position of component parts of a centrifugal fan with volute casing

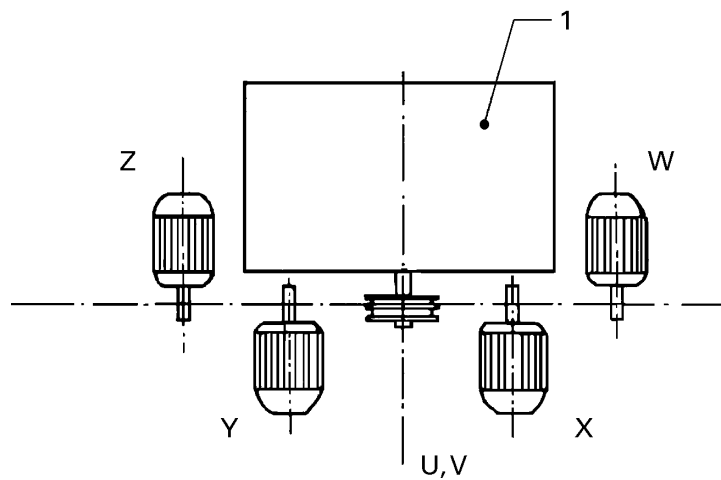


EXAMPLE

Inspection door: 90°

Motor: 315°

Figure 21 — Conventional designation of the angular position of components of an axial-flow, mixed-flow or other fan with coaxial inlet and outlet



Key

- 1 Fan
- U Below shaft level
- V Above shaft level

Figure 22 — Conventional designation of the alternative drive positions in plan view of a motor for belt or chain drive

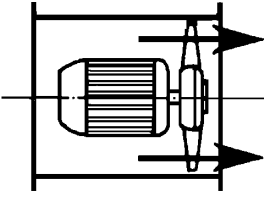
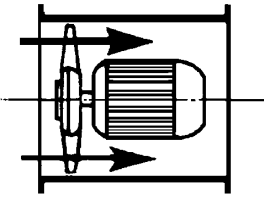
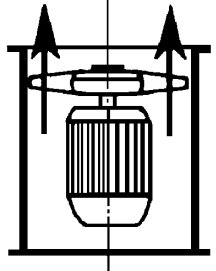
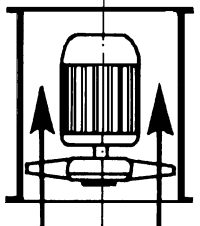
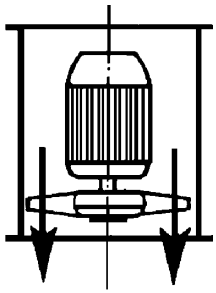
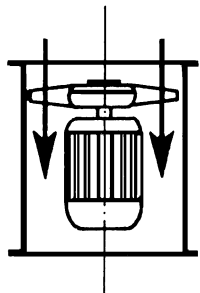
		A Motor upstream	B Motor downstream
Horizontal axis			
		A	B
Vertical axis	U Upward discharge		
	D Downward discharge		
		AU	BU
		AD	BD

Figure 23 — Conventional designation of the motor position in a direct-driven axial-flow, mixed-flow or other fan with coaxial inlet and outlet

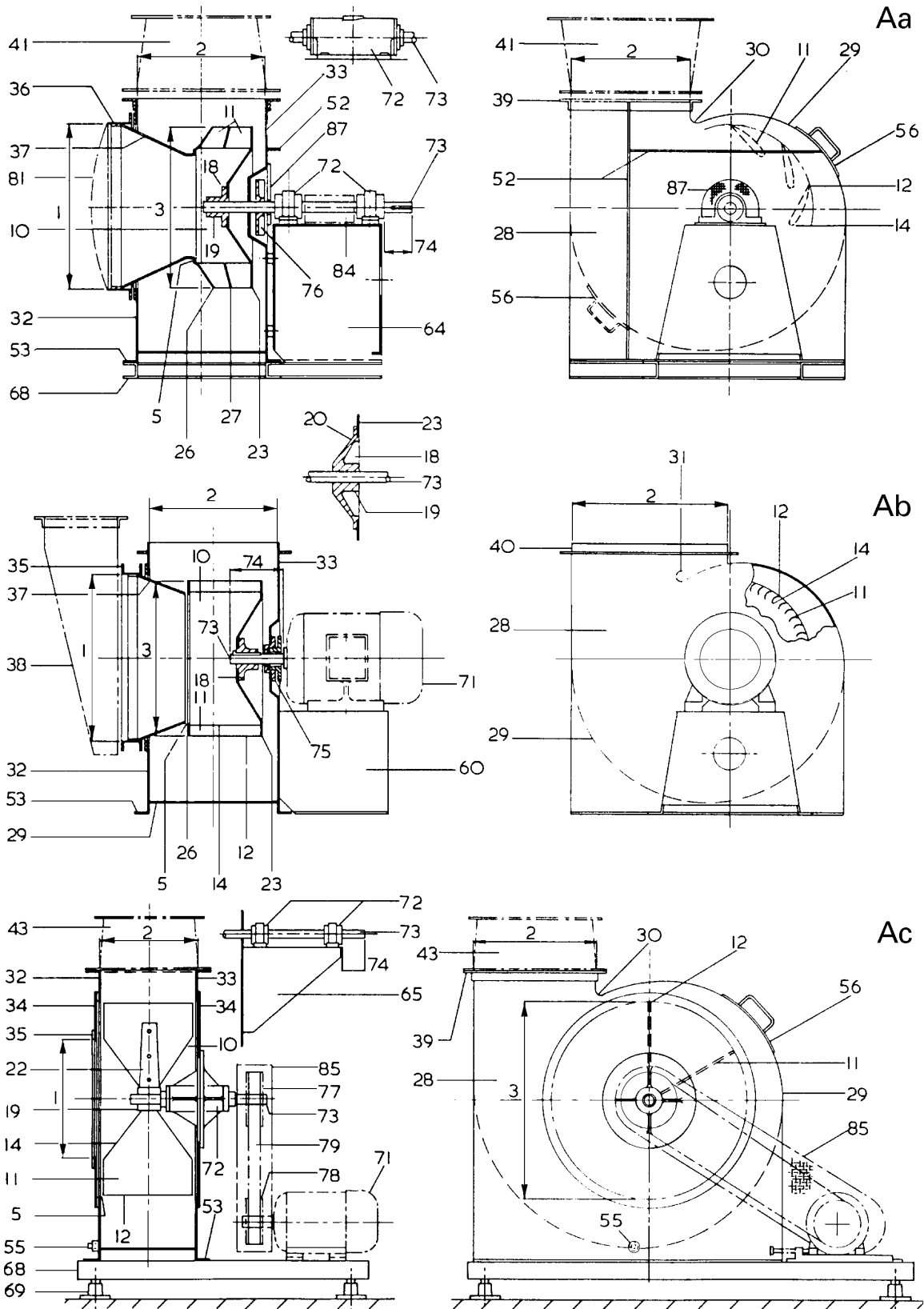


Figure 24 — Illustrations of centrifugal fans (see table 10)

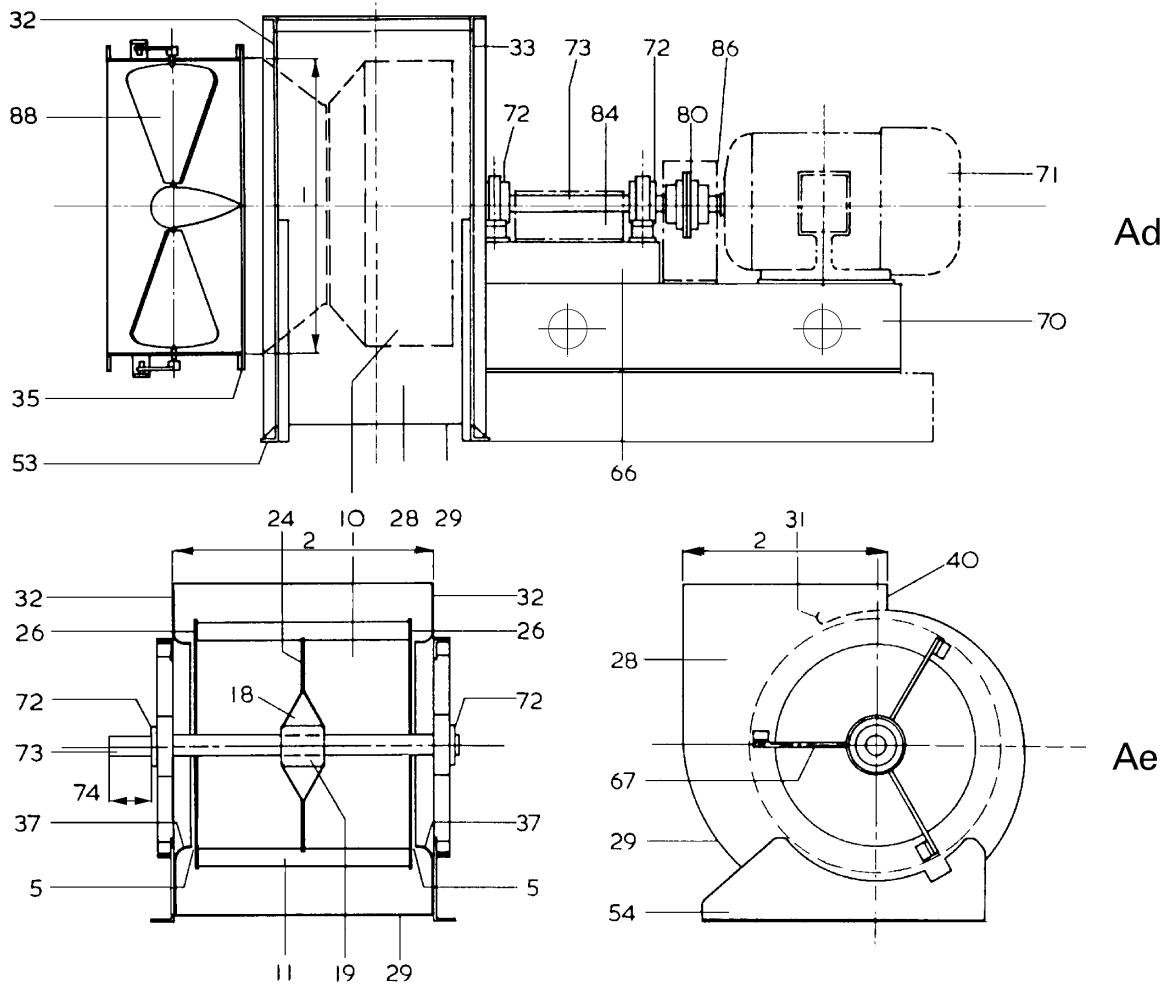


Figure 24 (continued)

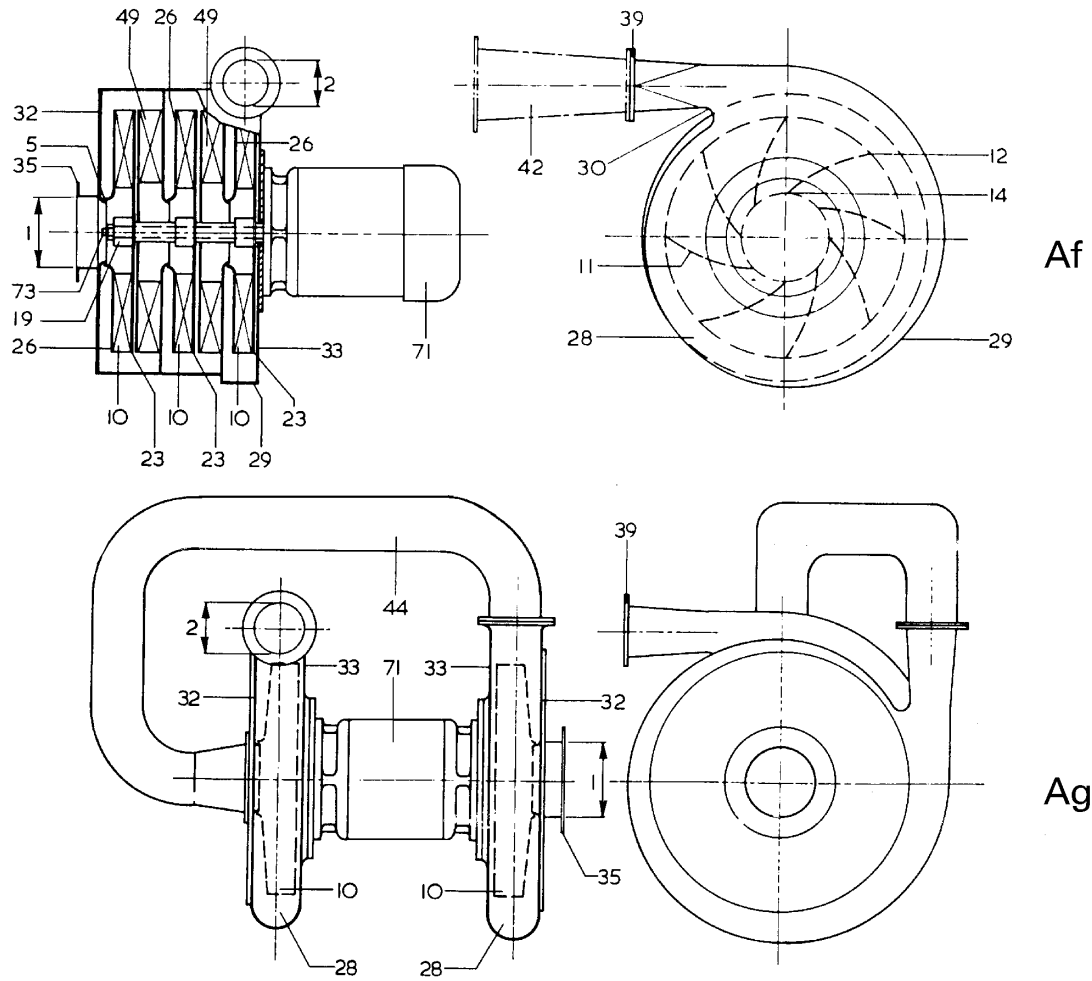
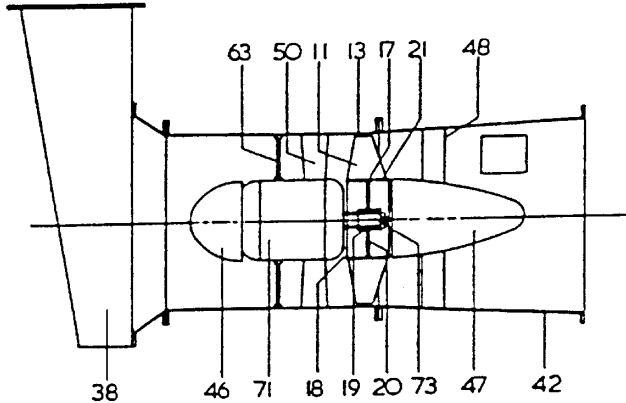
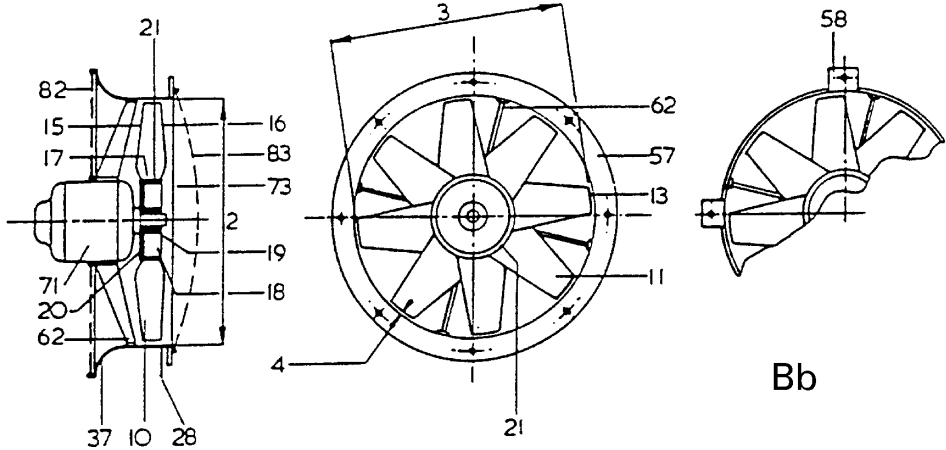
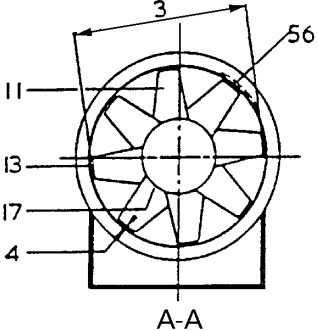
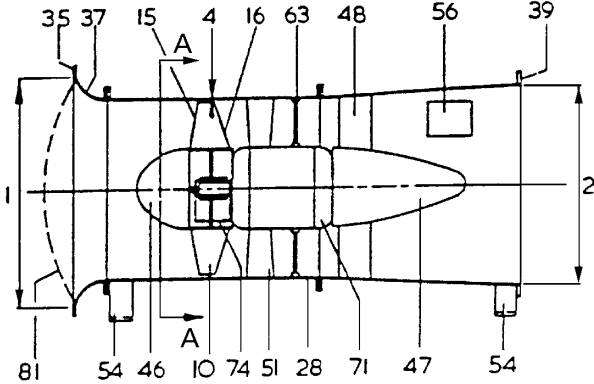


Figure 24 (end)



Ba



Bb

Figure 25 — Illustrations of axial-flow fans (see table 10)

Licensed copy: PONTYPRIDD COLLEGE, 11/11/2007, Uncontrolled Copy, © BSI

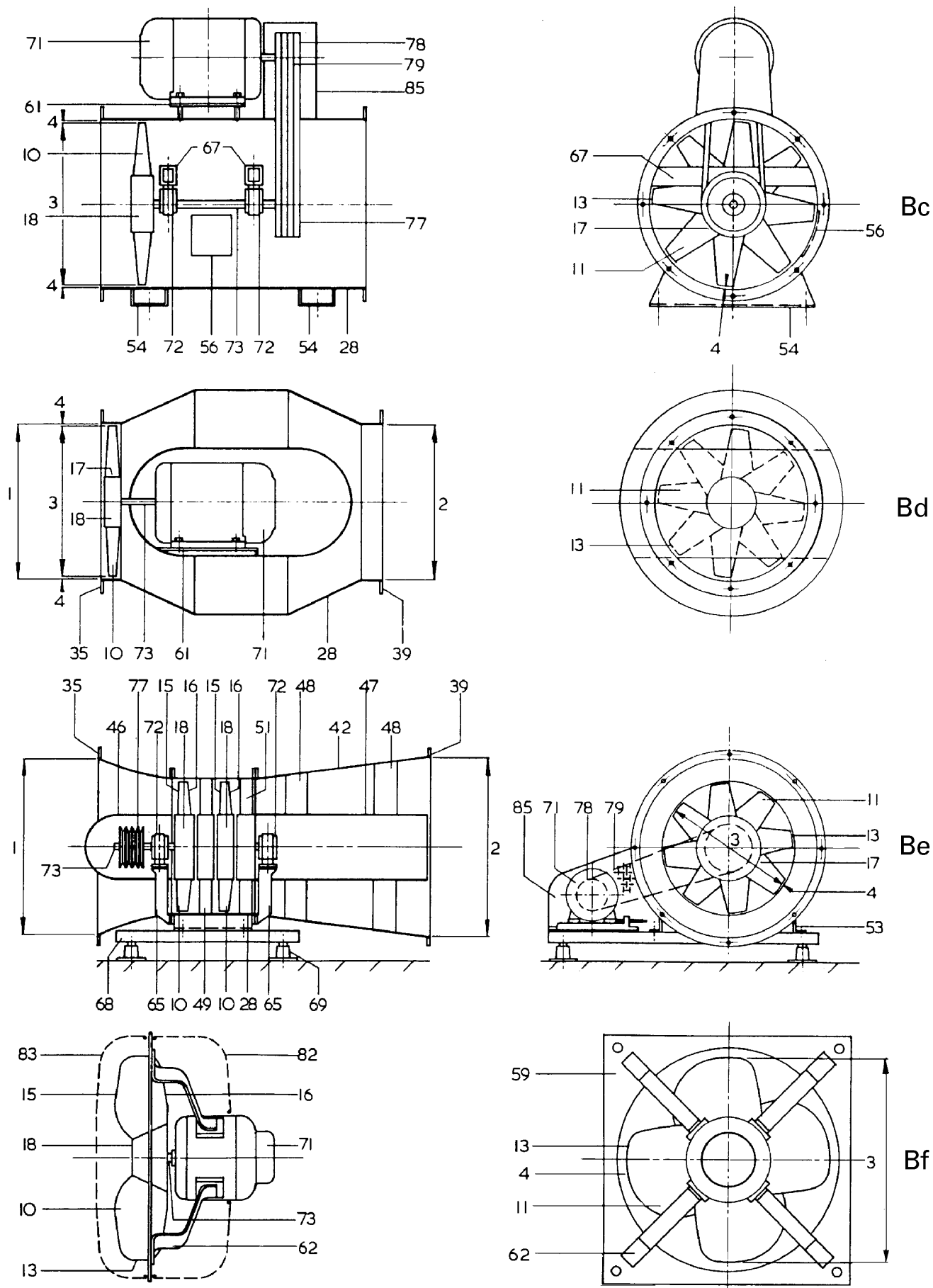


Figure 25 (end)

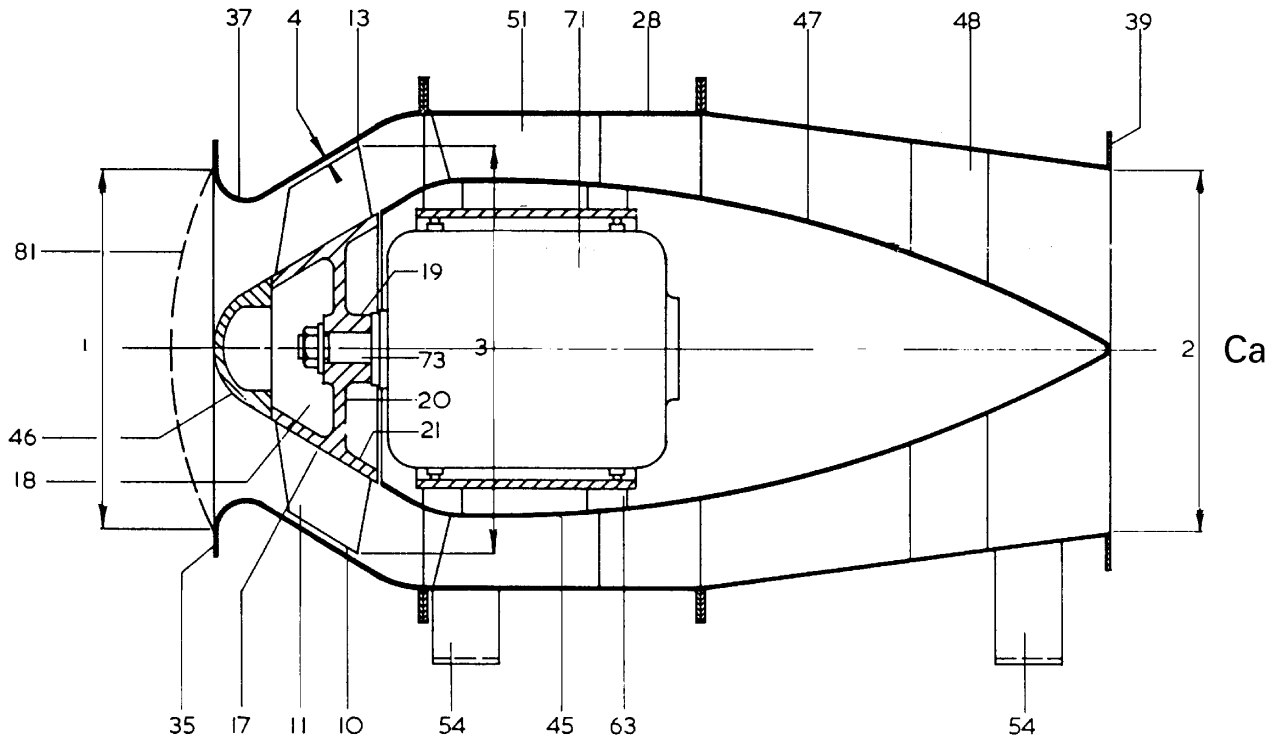


Figure 26 — Illustration of a mixed-flow fan (see table 10)

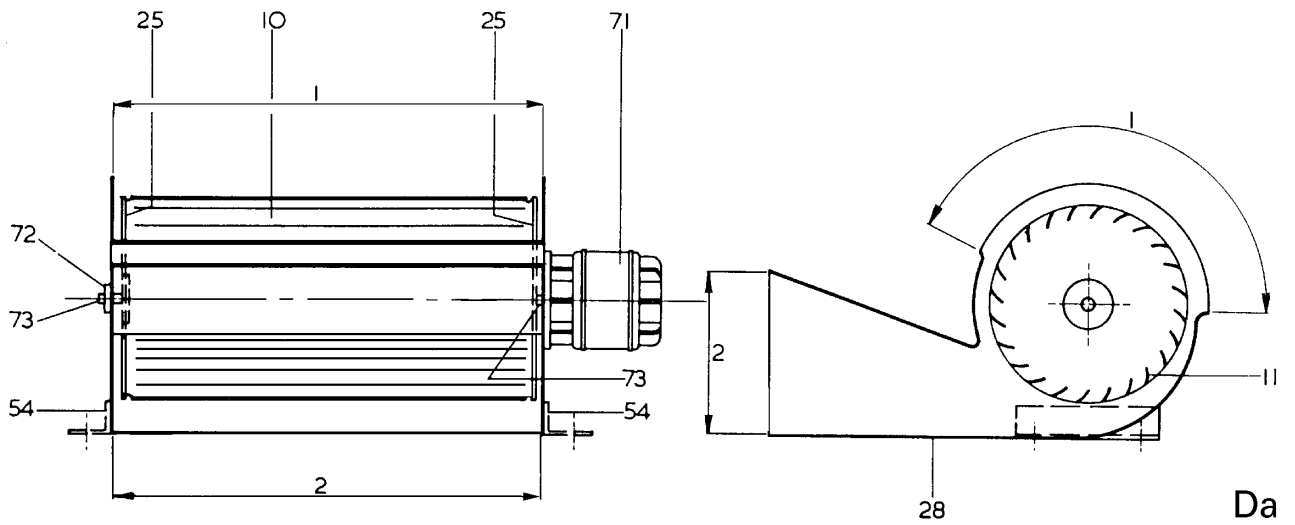


Figure 27 — Illustration of a cross-flow fan (see table 10)

Annex A (informative)

Examples

A.1 Example 1: Centrifugal fan

Coupling-drive heavy-duty centrifugal fan with impeller between bearings and designed for a duty of 38 m³/s against a fan pressure of 6,3 kPa.

Casing to be suitable for supporting the associated ducting. Side boxed inlet with vane control and diffuser on the outlet, terminating in a flange to match client's ducting. Casing to be fitted with an inspection door and to be suitable for handling radioactive fumes without detectable leakage.

Type of installation	Type "D"	3.4, figure 1
Type of fan as a function of its role	Ducted	3.5
Type of fan according to fluid path	Centrifugal	3.6
Suitability for pressure	High pressure, Category M/6	5.2, table 1
Casing construction	Category 3	5.3.1, table 2
Temperature category	Gastight fan, Category G	5.3.3, table 3
Drive arrangement	Coaxial coupling, arrangement 7	5.3.4, table 6
Inlet/outlet conditions	SD	5.5, table 8
Method of fan control	Vane control	5.6
Component parts	Outlet RD45	5.7, figures 18, 19, 20
	Inspection door RD315	
	Inlet box RD0	
Motor position	In-line	5.7, figure 20

A.2 Example 2: Axial-flow fan

Belt-drive axial-flow fan with duct-mounted motor for open-inlet, ducted-outlet installation with discharge diffuser. Duty fan pressure 1,0 kPa flow rate 20 m³/s at standard density. The fan is also required to operate under emergency conditions, with a gas temperature of 300 °C for 1 h. Inspection door on casing.

Type of installation	Type "B"	3.4, figure 1
Type of fan as a function of its role	Ducted	3.5
Type of fan according to fluid path	Axial-flow	3.6
Suitability for pressure	Medium pressure: Category L/2	5.2, table 1

Casing construction	Category 2	5.3.1, table 2
Temperature category	Smoke ventilating fan, Category D (HT/300/1,0)	5.3.3, table 3
Drive arrangement	Belt drive: Arrangement 9	5.3.4, table 6
Inlet/outlet conditions	ED	5.5, table 8
Component parts	Rotation RD	5.7, figure 16
	Inspection door 90°	
Motor position	Motor 0°	5.7, figure 21

BSI — British Standards Institution

BSI is the independent national body responsible for preparing British Standards. It presents the UK view on standards in Europe and at the international level. It is incorporated by Royal Charter.

Revisions

British Standards are updated by amendment or revision. Users of British Standards should make sure that they possess the latest amendments or editions.

It is the constant aim of BSI to improve the quality of our products and services. We would be grateful if anyone finding an inaccuracy or ambiguity while using this British Standard would inform the Secretary of the technical committee responsible, the identity of which can be found on the inside front cover. Tel: 020 8996 9000. Fax: 020 8996 7400.

BSI offers members an individual updating service called PLUS which ensures that subscribers automatically receive the latest editions of standards.

Buying standards

Orders for all BSI, international and foreign standards publications should be addressed to Customer Services. Tel: 020 8996 9001. Fax: 020 8996 7001.

In response to orders for international standards, it is BSI policy to supply the BSI implementation of those that have been published as British Standards, unless otherwise requested.

Information on standards

BSI provides a wide range of information on national, European and international standards through its Library and its Technical Help to Exporters Service. Various BSI electronic information services are also available which give details on all its products and services. Contact the Information Centre. Tel: 020 8996 7111. Fax: 020 8996 7048.

Subscribing members of BSI are kept up to date with standards developments and receive substantial discounts on the purchase price of standards. For details of these and other benefits contact Membership Administration. Tel: 020 8996 7002. Fax: 020 8996 7001.

Copyright

Copyright subsists in all BSI publications. BSI also holds the copyright, in the UK, of the publications of the international standardization bodies. Except as permitted under the Copyright, Designs and Patents Act 1988 no extract may be reproduced, stored in a retrieval system or transmitted in any form or by any means – electronic, photocopying, recording or otherwise – without prior written permission from BSI.

This does not preclude the free use, in the course of implementing the standard, of necessary details such as symbols, and size, type or grade designations. If these details are to be used for any other purpose than implementation then the prior written permission of BSI must be obtained.

If permission is granted, the terms may include royalty payments or a licensing agreement. Details and advice can be obtained from the Copyright Manager. Tel: 020 8996 7070.