

Fire tests on building materials and structures —

**Part 23: Methods for determination of
the contribution of components to the
fire resistance of a structure**

ICS 13.220.50

| |
|----------------------------|
| Confirmed December 2011 |
|----------------------------|

Committees responsible for this British Standard

The preparation of this British Standard was entrusted by the Fire Standards Committee (FSM/-) to Technical Committee FSM/1, upon which the following bodies were represented:

| | |
|---|--|
| Association of British Roofing Felt Manufacturers | Engineering Equipment and Materials Users' Association |
| Association of Building Component Manufacturers Ltd. | Eurisol (UK) Association of Manufacturers of Mineral Insulation Fibres |
| Association of Structural Fire Protection Contractors and Manufacturers | Fibre Building Board Organisation (FIDOR) |
| British Coal | Fibre Cement Manufacturers Association Limited |
| British Fire Services' Association | Fire Insurers Research and Testing Organisation (FIRTO) |
| British Floor Covering Manufacturers' Association | Fire Offices Committee |
| British Plastics Federation | Fire Protection Association |
| British Railways Board | Flat Glass Manufacturers' Association |
| British Rigid Urethane Foam Manufacturers' Association | Flat Roofing Contractors' Advisory Board |
| British Wood Preserving Association | Gypsum Products Development Association |
| Cement and Concrete Association | Home Office |
| Chemical Industries Association | Institution of Fire Engineers |
| Chief and Assistant Chief Fire Officers Association | Mastic Asphalt Council and Employers' Federation |
| Concrete Society | National Council of Building Materials Producers |
| Department of Education and Science | National GRP Construction Federation |
| Department of the Environment for Northern Ireland | RAPRA Technology Ltd. |
| Department of the Environment (Housing and Construction Industries) | Royal Institute of British Architects |
| Department of the Environment (Property Services Agency) | Steel Construction Institute |
| Department of Transport (Marine Directorate) | Timber Research and Development Association |
| Electricity Supply Industry in England and Wales | United Kingdom Antimony Oxide Manufacturers' Association |
| | United Kingdom Atomic Energy Authority |
| | Warrington Fire Research Centre |
| | Wood Wool Slab Manufacturers' Association |
| | Yarsley Technical Centre Ltd. |

The following bodies were also represented in the drafting of the standard, through subcommittees and panels:

| | |
|--|--|
| Association of Builders Hardware Manufacturers | Guild of Architectural Ironmongers |
| British Steel Industry | Hevac Association |
| Department of the Environment (Building Research Establishment, Fire Research Station) | Intumescent Fire Seals Association |
| Door and Shutter Association | National Association of Lift Makers |
| Electric Cable Makers' Confederation | Suspended Ceilings Association |
| | Thermal Insulation Manufacturers' and Suppliers' Association (TIMSA) |

Amendments issued since publication

| Amd. No. | Date of issue | Comments |
|----------|---------------|---------------------------------------|
| 9458 | January 1998 | Indicated by a sideline in the margin |
| | | |
| | | |
| | | |

This British Standard, having been prepared under the direction of the Fire Standards Committee, was published under the authority of the Board of BSI and comes into effect on 29 May 1987

© BSI 06-1999

The following BSI references relate to the work on this standard:
Committee reference FSM/1
Draft for comment 85/41321 DC

ISBN 0 580 15804 0

Contents

| | Page |
|--|--------------------|
| Committees responsible | Inside front cover |
| Foreword | ii |
| <hr/> | |
| 1 Scope | 1 |
| 2 Definitions | 1 |
| 3 Test conditions | 1 |
| 4 Apparatus | 1 |
| 5 Determination of the contribution of suspended ceilings to the fire resistance of steel beams | 1 |
| 6 Determination of the contribution of intumescent seals to the fire resistance of timber door assemblies | 4 |
| <hr/> | |
| Appendix A Guidance information | 8 |
| <hr/> | |
| Figure 1 — Non-loaded suspended ceiling test assembly | 12 |
| Figure 2 — Supporting construction for a loadbearing test | 13 |
| Figure 3 — Typical method applying test load to loadbearing test specimen | 13 |
| Figure 4 — Thermocouple weight | 14 |
| Figure 5 — Apparatus for determining the contribution of intumescent seals to the fire resistance of door and shutter assemblies | 15 |
| Figure 6 — Method of jointing the timber lippings | 16 |
| Figure 7 — Thermocouple arrangements to be used when determining the contribution made by intumescent seals | 17 |
| Figure 8 — Typical method for sealing joints between cover slabs | 18 |
| <hr/> | |
| Publications referred to | Inside back cover |
| <hr/> | |

Foreword

This Part of BS 476 has been prepared under the direction of the Fire Standards Committee, and describes the specific equipment and procedures for determining the contribution made by components to the fire resistance of structures. These components need not have any fire resistance in their capacity as isolated components. This Part should be read in conjunction with BS 476-20 which describes the general requirements for these methods.

This Part has been prepared in such a way as to allow reference to be made to the appropriate method of determining the contribution made by the designated component to the fire resistance of the structure by clause number only. Therefore clauses 5 and 6 are self-contained and cross refer to BS 476-20 where necessary. Methods for determining the fire resistance of loadbearing and non-loadbearing elements of construction are described in BS 476-21 and BS 476-22 respectively. The general changes made to the method for suspended ceilings compared with BS 476-8 are described in the foreword to BS 476-20. The method for determining the contribution of intumescent seals is a new test procedure developed as a quality control test by the intumescent sealants industry and has not previously been published.

An appendix is included which gives guidance and background information which will assist the designer and the testing laboratory to select and evaluate specimens which are representative of "in use" situations.

Attention is drawn to the Health and Safety at Work etc. Act 1974, and the need to ensure that the methods specified in this standard are carried out under suitable environmental conditions to provide adequate protection to personnel against the risk of fire and/or inhalation of smoke and/or toxic products of combustion.

CAUTION. The mechanical sawing of asbestos cement components attracts the provisions of the Asbestos Regulations 1969. Adequate methods exist to control levels of dust during such operations and these are detailed in the Control and Safety Guides¹⁾ issued by the Asbestos Research Council.

This Part, together with BS 476-20, BS 476-21, BS 476-22 and BS 476-24 supersedes BS 476-8:1972 which is withdrawn. However, the latter will still be made available on request since it is referred to in building regulations and other legislative documents.

A British Standard does not purport to include all the necessary provisions of a contract. Users of British Standards are responsible for their correct application.

Compliance with a British Standard does not of itself confer immunity from legal obligations.

Summary of pages

This document comprises a front cover, an inside front cover, pages i and ii, pages 1 to 18, an inside back cover and a back cover.

This standard has been updated (see copyright date) and may have had amendments incorporated. This will be indicated in the amendment table on the inside front cover.

¹⁾ Available from Asbestors Information Centre, Sackville House, 40 Piccadilly, London W1V 9PA.

1 Scope

This Part of BS 476 describes procedures for determining the contribution made by components to the total fire resistance of a structure or other elements used in conjunction with them when subjected to the relevant heating and pressure conditions specified in BS 476-20. This Part provides the requirements for specimen selection and/or its design and construction, the edge conditions, the equipment including any special apparatus or instrumentation, and the procedures and criteria as they apply to components which make a contribution to the fire resistance of a complete assembly. The methods are applicable to suspended ceilings protecting steel beams and intumescent seals for use in conjunction with single-acting, latched timber fire resisting door assemblies.

NOTE The titles of the publications referred to in this standard are listed on the inside back cover.

2 Definitions

For the purposes of this Part of BS 476, the definitions given in BS 476-20 and BS 4422 apply, together with the following.

2.1

suspended ceiling

a horizontal membrane and its associated suspension system which is provided below, and not in direct contact with, the structural, unprotected steel beams for the express purpose of protecting them from a fire environment, and which does not incorporate any loadbearing member of the structure

2.2

intumescent seal

a seal comprising material or a combination of materials with the property of swelling or foaming when exposed to heat, intended to improve the fire performance of the element of construction in which it is incorporated

3 Test conditions

The test conditions shall be as specified in BS 476-20 except, when performing tests in accordance with clause 5, the pressure immediately below the suspended ceiling shall be neutral, i.e. in equilibrium with the laboratory.

4 Apparatus

The apparatus for the test shall be as specified in BS 476-20. Additional equipment will be required in order to evaluate the contribution to the fire resistance provided by these specified components and this equipment shall be as specified in 5.4 and 6.3.

5 Determination of the contribution of suspended ceilings to the fire resistance of steel beams

5.1 General

5.1.1 This clause describes a method for determining the effective, protection that is provided by a suspended ceiling to a standard supporting construction of steel beams and specified concrete deck when exposed to specified conditions of heating and pressure from below.

The method is applicable to ceilings used in situations where the cavity above the ceiling is entirely surrounded by barriers which have the effect of restricting the transfer of hot gases (see A.1.1).

5.1.2 The suspended ceiling is protecting loadbearing steel beams and the method described permits the test to be carried out in either of the following ways:

- a) without any load being applied to the structural steel beams in which case only the maximum temperature of the beams is used to determine the limit of effective protection; or
- b) with the steel beams loaded, using one of the loading options given in A.4.2 of BS 476-20:1987, in which case the degree or rate of deflection is used to determine the limit of effective protection.

5.1.3 The results obtained by this method are not directly applicable to all types of steel beam/concrete floor deck assemblies. The method provides for additional temperature measurements to be taken in order that the potential contribution of the suspended ceiling to the protection of other steel beam/concrete floor deck assemblies may be assessed.

5.1.4 When it is required to determine directly the fire resistance of a particular floor or flat roof assembly with a suspended ceiling, the methods described in this clause are not applicable (see clause 7 of BS 476-21:1987).

5.2 Test specimen

5.2.1 *Number of specimens.* A single specimen shall be tested from its underside.

NOTE Whilst a suspended ceiling is generally an asymmetrical construction, the fire protection is only required with respect to fire attacking its underside.

5.2.2 Size of specimen. The specimen shall be of such dimensions that at least 4 m × 3 m is exposed to the furnace or full size if the element is smaller, and the specimen shall cover the full width and length of the furnace.

5.2.3 Design

5.2.3.1 The contribution to the fire resistance of steel beams, as provided by a suspended ceiling, shall be determined by erecting the test specimen beneath either the specified form of construction described in 5.2.5.2 or a suitable construction as described in 5.2.5.3. The specimen shall be designed such that it is suspended from the supporting construction in a manner representative of that used in practice. In the case where the beams are loaded, however, the suspension system shall be such as to allow the ceiling to deflect in sympathy with the beams.

The suspended ceiling shall normally be erected such that the ceiling is not closer than 5 mm nor further than 400 mm from the soffit of the steel beams. When the incorporation of other fittings, e.g. lighting units or duct entry grilles, requires a larger cavity the ceiling shall be fitted as close to the soffit of the steel beams as these items will allow (see A.1.2.1).

5.2.3.2 The ceiling suspension system shall be designed and erected such that the allowances for expansion do not exceed those provided in practice for the lengths of the members involved (see A.1.2.2); where gaps are left at ends to provide additional expansion they shall be reported.

5.2.3.3 The size and types of ceiling panels or tiles used shall not be mixed when designing the specimen (see A.1.2.3).

5.2.3.4 In use, many suspended ceilings incorporate lighting fittings, speaker grilles, duct openings, etc. but these items shall not be incorporated in a test specimen that is intended to evaluate the basic performance of the membrane. The influence of these items shall be assessed or tested separately (see A.1.2.4).

5.2.4 Specimen construction and condition. The construction of the specimen and the condition of the materials shall be in accordance with BS 476-20. Whilst it may be convenient to install the panels or tiles from above, the final closing of the cavity shall be performed from below as it would be in practice.

5.2.5 Supporting construction

5.2.5.1 The specimen shall be tested under either non-loadbearing or loadbearing conditions when the supporting construction shall be as described in 5.2.5.2 or 5.2.5.3 respectively.

5.2.5.2 For a non-loadbearing test the construction shall consist of steel beams supporting concrete slabs as shown in Figure 1 (see A.1.3).

The steel beams shall be of solid rolled type having a perimeter to cross sectional area ratio (P/A ratio) larger than or equal to 210 m⁻¹ (three-sided exposure) (a nominal serial size of 203 mm × 133 mm × 30 kg/m). The ratio between the total exposed surface area of steel beams and the plan area of the suspended ceiling shall be less than 0.8 : 1.

The cover slabs shall be constructed from lightweight aggregate concrete (density 1 600 ± 100 kg/m³) and shall be 150 mm thick.

When more than one cover slab is used to cover the area of the cavity then all joints shall be substantially sealed.

The perimeter wall of the cavity between the cover slabs and the suspended ceiling shall be manufactured from concrete with a density of 1 100 kg/m³ or less with a thickness of not less than 50 mm, or where a higher density concrete is used then an insulating materials shall be applied to the cavity face in order to provide similar degrees of insulation. The joints between this perimeter frame and the cover slabs shall also be substantially sealed.

The cover slabs shall be bedded on to the top surface of the steel beams using a compression gasket of dry mineral fibre insulation material of density 90 kg/m³ to 115 kg/m³, and 12 mm thickness. This gasket shall be full width and placed on the upper flange of the beam prior to the positioning of the floor slabs.

5.2.5.3 For a loadbearing test the construction shall be a floor construction comprising steel beams with a concrete deck and the loadbearing beams shall be loaded in a similar manner to that specified in BS 476-21.

NOTE 1 An example of a suitable construction is shown in Figure 2. (See also Figure 3.)

Either one or two loadbearing beams shall be used in the construction.

NOTE 2 These beams should preferably have a P/A ratio equal to 210 m⁻¹ (three-sided exposure) (a nominal serial size of 203 mm × 133 mm × 30 kg/m), usually grade 43A of BS 4360. These beams shall be simply supported.

The concrete cover slabs to the furnace shall be made up of precast lightweight concrete units (density 1 600 ± 100 kg/m³) and the test load may be transmitted to the test beam through these slabs. They shall be laid on the steel beams allowing them to deflect under the influence of load during the test. The butt joints between the slabs shall be adequately sealed (see A.1.3.2).

The perimeter wall of the cavity between the cover slabs and the suspended ceiling shall be manufactured from concrete with a density of $1\,100\text{ kg/m}^3$ or less with a thickness of not less than 50 mm, or where a higher density concrete is used then an insulating material shall be applied to the cavity face in order to provide similar degrees of insulation. The joints between this perimeter frame and the cover slabs shall also be substantially sealed.

The cover slabs shall be bedded on to the top surface of the steel beams using a compression gasket of dry mineral fibre insulation material of density 90 kg/m^3 to 115 kg/m^3 , and 12 mm thickness. This gasket shall be full width and placed on the upper flange of the beam prior to the positioning of the floor slabs.

Other suitable constructions may be used but these shall be reported and have an appropriate relationship with the suspended ceiling under test.

5.2.5.4 The cover slabs or topping materials shall be conditioned in a similar manner to the test specimen except that they can be used at moisture contents below representative levels (see **A.1.4**).

5.3 Specimen support conditions

When the specimen is full size all edges shall be fixed as in practice. For specimens that are smaller than the element of construction, all edges of the suspended ceiling shall be fixed to the specimen support frame or the furnace surround with any allowance for lateral movement limited to that specified in **5.2.3.2**.

NOTE Vertical movement of the ceiling edges or any suspension system need not be inhibited.

5.4 Additional apparatus

In addition to the apparatus specified in BS 476-20, the following apparatus is required if additional measurements are to be made (see **5.5.5**).

5.4.1 *Thermocouple weight*, as shown in Figure 4, for holding the specimen surface thermocouples in position. The legs of the thermocouple weight shall bear on the corners of the insulating pad so as to trap the thermocouple centrally between the resilient material and the underside of the pad.

NOTE The weight is only necessary when the upper surface of a ceiling membrane consists of a resilient insulation material.

5.5 Examination of specimen

5.5.1 Establish the dimensions and properties of the materials used in the construction of the specimen in accordance with BS 476-20 (see **A.1.5.1**).

5.5.2 Mount the test construction horizontally on top of the furnace, such that it is subjected to heating from the underside.

5.5.3 Position the furnace thermocouples at not less than one to every 1.5 m^2 , or part thereof, of the exposed surface area, with a minimum of four for specimens of less than 6 m^2 with the exposed surface area being the nominal area measured in the plane of the specimen. Distribute the thermocouples uniformly ensuring that no thermocouple is closer than 500 mm from the furnace walls, and with the thermocouple hot junctions at $100 \pm 10\text{ mm}$ from the surface of the specimen at the start of the test. Where the surface is irregular, measure the $100 \pm 10\text{ mm}$ from the median depth provided the junction is not nearer than 50 mm from any part of the exposed surfaces.

5.5.4 Position at least one pressure sensing head in the furnace such that the pressure conditions in the furnace are measured and controlled in accordance with BS 476-20 so as to maintain equilibrium pressure with the laboratory at a point 100 mm below the soffit of the specimen. In the case of an irregular profile maintain the pressure at the specified level 100 mm below an imaginary line between the lowest points of the irregular surface. Ensure that the pressure sensing head does not interfere with the deflection of the specimen during test.

NOTE The pressure sensing head is not required to be maintained at a fixed distance from the surface of the specimen during the test.

5.5.5 In order to measure the temperature of the steel beams, peen six thermocouples to each beam so that they are distributed uniformly along the length of each beam and are on the inside of the lower flange of the beam midway between the web and the toe of the flange (see **A.1.5.2**).

When measurements are to be made of the surface temperature of either the unexposed face of the ceiling tiles or panels or the soffit of the cover slabs, fix the thermocouples specified in **6.4.2.1** of BS 476-20:1987 in the conventional manner. When measurements are to be made on any horizontal fibrous or resilient insulation materials use a thermocouple weight (see **5.4.1**).

When measuring air temperatures within the cavity use thermocouples that comply with **6.4.2.1** of BS 476-20:1987.

5.5.6 When the test is to be performed with a loaded supporting construction, position the loading equipment, and locate in position and attach, if necessary, the equipment required for measuring vertical deformation at the point of anticipated maximum deformation.

NOTE As beams are simply supported, the point of maximum deformation can normally be assumed to occur at midspan.

5.6 Test procedure

5.6.1 Carry out the test in accordance with BS 476-20, with the exception of the furnace pressure conditions, and make any observations on the behaviour of the specimen, including the dislodgement of any tiles or the mode of failure in the case of a loaded supporting structure (see **A.1.6**).

5.6.2 In the case of a non-loaded supporting structure, monitor the temperature of the steel beams to check compliance with the maximum temperature criteria given in **5.7.1 a**).

5.6.3 In the case of a loaded supporting structure, monitor the deflection and the rate of deflection for compliance with the limiting deflections constituting a loss of loadbearing capacity as required in **5.7.1 b**).

5.6.4 Monitor all other thermocouples installed for the purpose of providing additional temperature information.

5.7 Criteria of failure, expression of results and test report

5.7.1 *Criteria of failure.* The performance of a suspended ceiling shall be determined by its ability to provide protection to steel beams to enable them to retain their loadbearing capacity. The limit of effective protection provided by the suspended ceiling shall be deemed to have occurred when any of the following criteria, as applicable, have been exceeded.

- a) In a non-loaded test the temperature at any measuring point on any beams reaches 400 °C.
- b) In a test with a loaded supporting construction the beams fail to satisfy the criteria given in **10.2.3** of BS 476-20:1987.

5.7.2 *Expression of results.* The test results shall be stated in terms of the elapsed time, to the nearest minute, between the commencement of heating and failure under one of the criteria given in **5.7.1**, as applicable. If no failures have been recorded then the elapsed time between the commencement of heating and the termination of the test shall be reported as the limit of the effective protection provided by the suspended ceiling.

NOTE A typical result may be expressed as follows.
Duration of effective protection: 74 min.

5.7.3 *Test report.* The test report shall include the results (see **5.7.2**) and any observations together with the information required by items a) to f) of clause **12** of BS 476-20:1987. In addition the following information shall be included.

g) Details of the expansion joints in the members supporting the ceiling and other features considered essential for the stability of the system. The expansion allowance per unit length of the grid system members and/or the spacing between expansion joints shall be stated and justified.

h) Details of any light fittings, grilles, openings and ducting that were incorporated in the specimen.

i) The test loading, if any, and its relationship to the design conditions.

j) The depth of the ceiling void.

k) The restraint conditions that applied to the suspended ceiling during the test.

l) Temperature/time curves for the steel beams.

m) The duration of effective protection to the steel beams.

n) An analysis of the behaviour of any expansion joints as determined by a post-test examination.

o) Where a loadbearing steel beam section has been tested which does not have a perimeter to cross-sectional area ratio of 210 m⁻¹, the reason for the deviation, and the limiting effects on the tested section.

6 Determination of the contribution of intumescent seals to the fire resistance of timber door assemblies

6.1 General

6.1.1 This clause describes a method of test for determining the effective sealing capability of intumescent materials or systems in the context of sealing door to frame clearances in timber door assemblies (see **A.2.1**).

The results obtained from this test are applicable for use on proven single acting, single-leaf latched timber door assemblies of sizes up to that tested but not greater than 2 100 mm by 926 mm at a thickness equal to that of the tested specimen.

The test is suitable for evaluating intumescent sealing systems for use on timber fire resisting doors of up to 1 h fire resistance.

The timber door assemblies to which these intumescent seals may be applied will have been tested in accordance with BS 476-22 and have satisfied the integrity criterion for a period equal to or less than that obtained in the test whilst incorporating any other form of heat activated seal. These seals may not be applied to timber door assemblies which when so tested have deflected more than 15 mm from the vertical during the relevant period of the test.

6.1.2 The suitability of any sealing system for use on timber door assemblies of any other configuration, i.e. unlatched single doors, double leaf assemblies etc., or doors constructed of other materials can only be evaluated by subjecting a full sized door assembly, complete with seals, to test in accordance with clause 6 of BS 476-22:1987.

6.1.3 An analysis of the results of many fire tests on full size timber door assemblies has established that 15 mm is a representative maximum deflection. Some doors with proprietary non-timber cores have deflected considerably more than 15 mm and hence the scope of the test is limited to timber door assemblies.

6.2 Test specimen

6.2.1 General. The specimen shall consist of a strip or set of intumescent seals of the type to be evaluated, fixed into the hardwood edging of the testing rig described in 6.3.1 and in a similar manner as in practice (see A.2.2).

6.2.2 Specimen size. The width of the strip and the thickness of the rig panels shall in all cases be the same as would be used on the door and frame in use. The length of the strip is governed by the size of the testing rig but the seal shall be continuous around the periphery of the panel or frame, forming butt joints at the corners, unless other joints are to be formed in practice, when the joints shall be as in practice.

6.2.3 Design of specimen

6.2.3.1 The upper surface of the intumescent seal shall be level with, or not more than 1 mm below, the surface of the timber lipping. In such cases the seal shall be installed in a similar manner to that to be used in practice.

6.2.3.2 Where a single intumescent strip is to be used the strip shall be fitted into a groove machined into the outer, fixed hardwood lipping as in practice such that the centre line of the lipping and the centre line of the seal are coincident. Where two or more strips are to be used, these shall be equally distributed about the centre line of lipping as they would be in accordance with the manufacturer's instructions.

6.2.3.3 In situations where the seal is designed to be fitted to the moving element of a door assembly, i.e. the edge of the leaf, then it is permissible to mount the seal or seals into the hardwood lipping fixed to the central, pivoted panel of the testing rig as installed, or in accordance with the manufacturer's instructions.

6.2.4 Specimen condition. The condition of any hygroscopic material used in the manufacture of the test specimen shall be in accordance with BS 476-20.

6.3 Additional apparatus

In addition to the apparatus specified in clause 6 of BS 476-20:1987 the following apparatus is required.

6.3.1 Testing rig (see Figure 5 and A.2.3)

6.3.1.1 The testing rig shall be low carbon steel angle (60 mm × 30 mm × 5 mm thick) with mitred welded corners to form a square frame 600 mm × 600 mm. A central low carbon steel plate (nominally 5 mm thick) shall be fixed to a diagonally mounted 15 mm diameter round low carbon steel bar which is retained in bushes at each end. The central panel shall be retained in a diagonally central position by means of locking collars bearing against the face of pivot blocks on the diagonal shaft such that the gap between the central panel and the outer frame is equal on all edges.

6.3.1.2 A bolt manufactured from 6 mm thick × 20 mm wide low carbon steel plate shall be able to slide through a bolt tunnel mounted on the back face of the central low carbon steel panel such that the tip of the bolt engages in a keep mounted to the back of the outer frame.

6.3.1.3 An arm with a deflection limit adjustment screw shall be fixed to the panel as shown in Figure 5.

6.3.1.4 On the rear face of the frame a 100 mm diameter pulley wheel shall be mounted on a steel pulley bracket to facilitate the application of a load to the central panel at the point shown in Figure 5. A wire rope shall be attached at the position shown on the central panel so that the rope passes over the pulley and hangs down below the rig for a length of approximately 300 mm. A weight, or a weight pan and weights, of mass 7.5 kg is attached to the lower end of this wire rope.

6.3.1.5 The flush face of the outer frame shall be clad with a non-combustible insulating board, or laminated boards, with a density of 680 kg/m^3 and a thermal conductivity of between 0.14 W/(m K) to 0.18 W/(m K) to a thickness equal to the thickness of the door to which the results are normally to be applied. A lipping of hardwood (of density between 650 kg/m^3 and 750 kg/m^3) shall be affixed to the inner edge of this cladding to the full thickness of the insulating board and $19 \pm 1 \text{ mm}$ deep. The lippings to both the inner panel and the outer frame shall be glued to the cladding with a suitable adhesive.

NOTE Resorcinol formaldehyde is the preferred adhesive, but in the case of tests for use with FD30 door assemblies a urea formaldehyde adhesive or similar may be used as an alternative (see A.2.3).

The central panel shall be clad in a similar manner and a similar hardwood lipping shall be incorporated in the perimeter of this panel to a nominal depth of 19 mm but finally sized such that the gap between the lipping on the frame and central panel is $3.5 \pm 0.5 \text{ mm}$ on all faces.

6.3.1.6 The method of jointing the lippings shall be as given in Figure 6. All surfaces of the joint shall be coated with adhesive and there shall be no gaps between sections which exceed 0.5 mm .

Other methods are acceptable, particularly if the type of seal is difficult to fit, or has its expansion restricted by such methods of jointing, subject to the method not causing or permitting gaps to develop that may influence the integrity rating of the seal (see A.2).

6.4 Examination of specimen

6.4.1 Establish the dimensions and properties of the sealing materials and the timber lippings used in the test construction in accordance with BS 476-20.

6.4.2 Mount the testing rig, complete with its cladding and incorporating the seal under evaluation, in an associated test construction in the vertical face of the testing furnace.

Mount the rig such that the clad face is flush with the associated construction on the exposed face. Ensure that the associated construction is not greater than 100 mm thick. Ensure that the test rig is securely fixed within the hole in the associated construction by means of additional brackets if required.

6.4.3 Position not less than four furnace control thermocouples 100 mm from each edge of the test rig and 100 mm from the face of the associated construction, as shown in Figure 7 (a). When multiple rigs are in use, the two thermocouples between adjacent rigs will be common to both as shown in Figure 7 (b).

6.4.4 Set the adjustable deflection limiting screw to give 15 mm deflection.

6.4.5 Engage the bolt that locks the central pivoted panel in line with the outer frame. Apply a mass of 7.5 kg to the loading system.

6.5 Test procedure

Carry out the test in accordance with BS 476-20 maintaining a positive pressure within the furnace, relative to the laboratory atmosphere of $(10 \pm 2) \text{ Pa}$ at a height corresponding with the top edge of the central panel, i.e. level with the upper horizontal gap.

After a test on a panel designed for evaluating seals for use on 30 min resisting door assemblies has been running for 15_{+1}^0 min , carefully withdraw the bolt used to retain the central panel in a vertical position. Perform this operation in such a way as to create a minimal disturbance to the position of the panel. For tests on 54 mm thick panels designed for evaluating seals for use on 60 min resisting door assemblies, withdraw the bolt after 30_{+1}^0 min .

NOTE The withdrawal of the bolt automatically applies the load to the central panel (see A.2.4).

Note the deflection of the panel immediately after the withdrawal of the retaining bolt and continue to monitor the deflection under either the maximum limiting deflection of 15 mm is reached or until the test is terminated. Record the time at which the limiting deflection is reached.

Monitor the gap between the inner pivoted panel and the outer fixed frame for loss of integrity as described in 10.3.2 of BS 476-20:1987.

NOTE As all of the edges of the rig are subjected to positive pressure furnace conditions the use of the gap gauges is not relevant.

Disregard any deflection that occurs after termination of the heating or during the extinguishing procedures.

6.6 Criteria of failure, expression of results and test report

6.6.1 Criteria of failure. The contribution to the fire resistance provided by the intumescent seal shall be determined by compliance with the criteria of integrity. Failure of the intumescent seal shall be deemed to have occurred as a result of either the presence of continuous flaming on the unexposed face or ignition of the cotton fibre pad as described in 10.3.2 of BS 476-20:1987.

6.6.2 Expression of results. The contribution of the intumescent seal to the integrity of a fire resisting door or shutter assembly shall be expressed in terms of the period for which the sealing system satisfied the integrity criteria of the test. The thickness of the test panel shall also be given.

NOTE A typical result may be expressed as follows.
Effective contribution to the fire resistance provided by the intumescent seal: 39 min in conjunction with a 44 mm thick panel.

6.6.3 Test report. The test report, and any associated document or letter expressing the contribution to fire resistance, shall include the result (see **6.6.2**), the time at which the maximum deflection of 15 mm was reached or the magnitude of the maximum deflection, together with the information required by items a) to d) of clause 12 of BS 476-20:1987. In addition the following information shall be included.

- e) A full description of the intumescent seal including any applied protection.
- f) The size and cross-sectional area of the total seal and the size and cross-sectional area of the intumescent material if these are different.
- g) The position of the seal(s) in the lipping relative to the exposed face of the testing rig.
- h) The gap between the lippings on all four faces of the panel.
- i) The density of the timber used as the lipping material.
- j) The following statement:

A door which has achieved an integrity rating under BS 476-22 may have its intumescent seal(s) replaced by those which have achieved the same integrity rating under this test procedure, provided that the door assembly which was tested in accordance with BS 476-22 satisfies the following requirements.

- i) The assembly shall consist of a leaf and frame, together with associated, proven essential ironmongery which has previously been tested in accordance with clause 6 or 7 of BS 476-22:1987 as an insulated or partially insulated door. It shall have satisfied the integrity requirement for the specified period, when fitted with other intumescent seals which have a cross-sectional area not greater than that tested in this test.

ii) The required integrity rating shall not exceed 60 min.

iii) The operating mode shall only be a latched, single leaf, single swing door assembly.

iv) The leaf size shall not be greater than that tested in accordance with BS 476-22 and shall not exceed 926 mm in width or 2 100 mm in height regardless. 30 min fire resisting doors shall be not less than 44 mm thick and 1 h fire resisting doors shall be not less than 54 mm thick.

v) When tested in accordance with BS 476-22 the top edge of the leaf of the door assembly shall not have deflected at any point along its top edge by more than 15 mm from its original position.

vi) The frame shall be of solid timber. Softwood shall have a density of not less than 500 kg/m³ for FD30 doors. Hardwood shall have a density of not less than 650 kg/m³ for FD60 doors.

vii) the leaf shall be timber faced, lipped with hardwood of a density greater than 650 kg/m³ down the two long edges and shall consist of timber across the two short edges.

The method of test does not provide any information relating to the need to protect hinges with additional intumescent material, particularly in the lower, negative pressure zone of the furnace. When applying the result of this test to seals to be fitted to the assembly under consideration, any protection to the hinge positions used in the full scale BS 476-22 test shall be used in this assembly without change to either the quantity or type of protection.

If any of the above requirements are not complied with then the complete assembly shall be re-tested with the new intumescent material fitted.

Appendix A Guidance information

A.1 Contribution of suspended ceilings protecting steel beams

A.1.1 *General*

The objective of the test described in clause 5 is to determine the limit of effective protection that can be provided by a suspended ceiling to a structural floor that is constructed from concrete slabs supported by unprotected steel beams. The results obtained from this test are only directly applicable to this type of construction due to the criteria used. It is recommended, however, that temperatures other than those are measured and recorded. These temperatures may provide guidance that may enable the ceiling to be used to protect other forms of construction. Care should be exercised in the use of these measured temperatures as they are directly related to the thermal conductivity and thermal inertia of the supporting construction. If the ceiling is used in conjunction with other forms of construction, the temperature rise will be dependent upon the thermal characteristics of the structure being protected.

The test procedure provides for two equally acceptable methods of test, one test being performed with a load applied to the supporting construction and evaluated by means of loadbearing capacity, whilst the alternative procedure allows the use of an unloaded construction adjudged by compliance with a predetermined temperature rise criterion applied to the steel beams. It should be noted that current evidence suggests that most suspended ceilings will obtain a higher duration of effective protection when evaluated in conjunction with a loadbearing supporting construction rather than when evaluated by means of the maximum temperature rise criterion. The criterion used for non-loadbearing tests is well below accepted critical temperatures for low carbon steel. It should be recognized, however, that it will be more expensive to evaluate a loaded assembly due to the damage that is done to both the steel beams and the cover slabs which are normally re-usable after a test during which no load has been applied.

A.1.2 *Design of specimen*

A.1.2.1 The method requires that the suspended ceiling is constructed in such a manner that the ceiling is erected, under normal circumstances, not less than 5 mm below, nor more than 400 mm from, the soffit of the steel beams.

If the suspended ceiling is closer than this it is recommended that the assembly be tested as a normal floor or flat roof construction, tested in accordance with BS 476-21, as the heat transfer will not be significantly different from a conventional ceiling assembly. At the other end of the scale the volume of air and the amount of exposed cavity wall will both affect the temperature rise in the cavity and if the size of the ceiling void is not controlled then variable temperature rises may well result.

A.1.2.2 An additional requirement is that the expansion joint should have an expansion allowance proportional to the length of the member into which it is fitted. This will frequently cause a conflict in the design of a specimen as one expansion joint is not designed to provide the allowance required in, for example, a 4 m length, but two such joints will provide a much greater allowance than would normally be required for a 4 m member.

It is important that the number of joints do not provide excessive allowance and the specimen should always be constructed with insufficient allowance if it is not possible to provide a joint that accommodates the expected expansion exactly.

The effect of a fire impinging on the middle of a large expanse of suspended ceiling will be to cause the heated portion to expand against the rigid restraint provided by the cooler remainder of the ceiling. This can be best represented on a small test specimen by abutting the ends of all members in the suspension system tightly to the perimeter edges of the furnace or the supporting frame, such that all thermal expansion has to be incorporated within the members in the suspension system.

A.1.2.3 If a specimen is constructed with tiles or panels of different thickness, density or thermal characteristics it will be impossible to evaluate the effective protection of the individual tiles or panels as the beam temperature will be the result of the integrated heat flow through the various ceiling materials. It is permissible, however, to test a ceiling made up of similar panels that only differ with respect to the pattern on the exposed face.

A.1.2.4 Light fittings and heating ducts affect the behaviour of a suspended ceiling in two different ways. Because these items are often suspended directly or, as in the case of the heating grille, indirectly via the trunking back to the floor slab above they are therefore capable of providing support to the suspended ceiling. The introduction of these components into the membrane is, however, likely to affect the heat flow through the ceiling due to the thermal bridges and imperfections that they may introduce. It is for these reasons that the effect of these components should be evaluated by means of a separate test in accordance with clause 5.

A.1.3 Supporting construction

A.1.3.1 For non-loadbearing tests, the rate of temperature rise of the steel beams is proportional to the exposed steel area and inversely proportional to the mass of the beams. The beams are specified by the ratio of their surface area, perimeter (P) and the cross-sectional area (A). It is important to note that the " P " term is based only on the surfaces exposed to the cavity heat and therefore the top surface of the upper flange is not taken into account in determining the value of " P ".

In order to keep the thermal characteristics of the cavity similar, regardless of the plan area of the ceiling, a ratio between the exposed surface area of the steel beams and the ceiling area has been introduced.

The thermal characteristics of the cavity edge construction have also been identified as a factor in the heat balance of the cavity. For this reason it is important to control this feature and an insulated edge is specified. Where it is not possible to use concrete of the specified density and thickness, the face should be insulated with an insulating board or fibre mattress to give similar thermal characteristics. The loss of heat through gaps between the floor slabs and the perimeter cavity walls, or even between individual slabs, has been identified as an important factor in the total heat balance in the cavity. It is important to seal all gaps to produce an airtight seal.

This can be achieved by means of heavily compressed mineral fibre or a combination of mineral fibre, plaster or sealing mastics. Figure 8 shows a method that can be adopted for sealing joints in the cover slabs.

A.1.3.2 For loadbearing tests, when evaluating the effective protection of a suspended ceiling with a load applied to the supporting construction, it is important to ensure that the floor slabs do not produce a bridging action from one cavity wall to the other. It is important, therefore, for the beams to carry their own "topping" constructions and be prepared as individual beams.

The seals between these slabs should be able to accommodate differential movements without allowing increases in gas leakage rates that may affect the thermal balance in the cavity.

A.1.4 Condition of cover slabs

The method requires that the cover slabs are subject to moisture content control. This is a requirement as excessive moisture in the cover slab could lead to a suppression of the cavity temperature, and hence the temperature of the steel beams. When suspended ceilings are evaluated without a load on the supporting construction, the cover slabs become a re-usable component. It is extremely difficult to increase the moisture content of the slabs and for that reason it is permissible to use these slabs at lower than representative moisture levels.

A.1.5 Setting-up procedure

A.1.5.1 In the construction of the suspended ceiling and its supporting construction many individual components of nominally the same dimension are used. It is important, therefore, not only to determine the size of these components, but also to establish the magnitude of the variation between them. The beams used in the supporting construction also need to be measured in order to determine or confirm their P/A ratio.

A.1.5.2 The fire resistance of a non-loadbearing test specimen is determined by means of the temperature rise in the steel beams which form part of the supporting structure. It is important, therefore, that these temperatures are measured accurately. One of the most common causes of error when using unsheathed thermocouples is the forming of a secondary couple between the two wires to make up the thermocouple. These wires sometimes make a couple just outside the flange of the beam due to the proximity of the wires as they emerge from the hole into which they have been peened. A suitable technique that overcomes these problems is to drill two smaller holes, close to each other, and peen each wire making up the couple into separate holes. It is recommended that the holes are not more than 4 mm apart.

It should be noted that the cover slabs are not monitored with respect to unexposed face temperature rise or imperviousness by means of the cotton pad.

A.1.5.3 When measurements are to be made of the cavity temperature or the temperature of the soffit of the floor slabs, the number of points of measurement will be dependent upon the distance between the ceiling and the soffit of the steel beams. Where this distance is large, the temperatures in the cavity will be more uniform. Narrow gaps are, however, likely to cause temperature rises in one cavity that may not influence the temperatures in the other cavities and it is recommended that each cavity should be monitored individually.

A.1.6 Test procedure

The fire behaviour of a suspended ceiling is often dependent upon the efficiency of the expansion joints. An analysis of the behaviour of these components will be of assistance in determining possible causes of failure or assisting in the formulation of any subsequent assessments.

A.2 Contribution of intumescent seals

A.2.1 General

Since the introduction of positive furnace pressure in the 1972 revision of BS 476-8, it became virtually impossible to maintain the integrity of an insulated separating element for any sensible period of time if a gap was present in the test construction at the start of the test or developed during fire exposure. In the majority of static elements, e.g. partitions and floors, such gaps were easily eradicated by adequate use of fillers and sealants. Moveable elements, e.g. doorsets and shutter assemblies, presented special problems as gaps had to exist around their perimeter in order that they operated without hindrance during normal use. In order to maintain their integrity for the periods required in regulations these gaps had to be eliminated during the heating period.

Some test constructions expand during heating and, depending upon the size of the element and the size of the gap, a partial seal can develop naturally. In other elements, e.g. timber doorsets, some shrinkage can occur which would have the effect of increasing, rather than decreasing, the risk of a loss of integrity. In these cases heat activated sealing systems had to be fitted and the most common of these in current use is the intumescent seal, which, whilst letting smoke through in the early stages of the test, will form effective seals in the later stages.

For the more complex assemblies, i.e. double-leaf doorsets, doorsets without latches and assemblies incorporating overpanels, the intumescent seal often performs a secondary function which helps to maintain the stability of the leaf or leaves by either generating, or avoiding the generation of, imposed forces on the assembly during fire exposure. The suitability of any particular seal that is required to play such a secondary role can only be determined by subjecting the complete assembly to the test described in clause 6 of BS 476-22:1987.

In the case of simpler elements, i.e. standard size, latched, single acting timber door assemblies, the requirement for the seal to perform any secondary function is virtually eliminated. The latch, in combination with the hinges, is capable of providing all of the required stability without any assistance from the intumescent materials and as a result the intumescent seals are only required to fill the gap around the perimeter of the leaf. The doorset design, including all of the hardware, should have demonstrated its ability to remain stable enough to satisfy the criteria of the door test described in clause 6 of BS 476-22:1987 using intumescent seals where necessary. The need to change seals for either supply or cost reasons should not, however, require the whole assembly to be retested and such an assembly should be able to incorporate any seal that has demonstrated its ability to provide the required contribution to the fire resistance when tested in combination with an equivalent thickness of panel to the door being used.

For these reasons, this interchangeability is restricted to single-acting timber latched door assemblies of up to 2 100 mm height and 926 mm width where the door component is faced with timber or other ligno-cellulosic materials and incorporates an edging of similar materials not less than 25 mm thick. The door leaf should not incorporate any metal components, either structurally or as facings, and the void between the edging and the faces may be filled only with wood or other ligno-cellulosic products. The frame into which this leaf is hung should also be of solid timber or incorporate a facing of ligno-cellulosic material not less than 25 mm thickness applied to an inert, non-metallic core.

The test is not suitable for evaluating the acceptability of intumescent seals for use on timber based doorsets that are to be hung in metal frames. Such combinations and all other more complex assemblies are required to be tested as complete doorsets as described in BS 476-22, in order to evaluate the suitability of the seals for such use.

It is also unsuitable for evaluating concealed intumescent sealing systems for general applications, as the method of jointing will inhibit the free expansion of the seals, resulting in artificial and premature failure. If the test method is to be used for research or development of concealed intumescent systems then the method of jointing the corners should reflect the methods to be used in practice.

NOTE It is not conventional for all edges of the leaf to incorporate concealed intumescent seals.

A.2.2 Specimen construction

As the width and cross-sectional area of the seal under test is the only size for which the result is valid it is important that the specimen size selected is representative of that which is proposed to be used in practice. Similarly, the thickness of the panel, and hence the timber lipping, should also be identical to the door to which the results are to be applied.

When the seals are of the pre-formed strip type, the details at the corners should be as recommended by the manufacturer of the intumescent material.

Where the strip is fitted in the conventional manner, i.e. in the lipping to the fixed outer frame, the jointing detail is not as important as it is for seals that are fitted to the lippings attached to the central, pivoted panel.

The intumescent seal should be fixed in accordance with the manufacturer's recommendations. Where more than one technique is recommended, the method that is considered to be the least effective should be used although it is permissible to use alternative fixings in one rig.

A.2.3 Testing rig

As the testing rig incorporates a pivoted central panel it is important that the rig is maintained such that the central panel moves freely. Due to the nature of the environment the use of grease on the pivots should be either avoided or used vary sparingly. The application of powdered graphite should be adequate to ensure reasonably free movement without the attendant risk of melting or ignition associated with the use of grease.

Although the results obtained from this test are applied to single-acting, single leaf doors which will invariably incorporate a stop on the frame, it is not possible to incorporate a stop on the testing rig as the central panel pivots about a diagonal axis causing one of the corners to move into the furnace and the other out. For this reason greater "scouring" of the timber lippings will occur during a test using the rig than would occur when using a rebated frame, especially as the gap between the lippings is greater than that recommended in the test of a door assembly.

It is important, therefore, that the timber lippings are able to withstand this extra scouring and it is for this reason that the density of the timber recommended is 650 kg/m^3 or greater in order to take advantage of the slightly lower charring rates that such timber exhibits. It should be noted, however, that timber is normally quoted by nominal density values and fairly wide variations can occur within a species. Physical checks should be taken on batches of timber to be used to ensure that the density of the timber is above the 650 kg/m^3 required.

The actual materials used for cladding the steel components of the rig are not important in the behaviour of the specimen unless they exhibit high shrinkage rates or high distortions which could cause gaps to develop between the hardwood lippings and cladding material. The main purpose of these materials is to keep the steel framework relatively cool and hence it is their thermal conductivity and to some extent their density that is most important. Boards manufactured from bonded exfoliated vermiculite or reinforced calcium silicate or combinations of both are suitable for this purpose.

A.2.4 Test procedure

The withdrawal of the bolt after 15 min applies the 7.5 kg load to the edge of the central frame. This load is not intended to represent any externally applied force but is designed to reproduce typical internally generated stresses caused by the heating of the timber door. As intumescent seals behave in dissimilar ways some seals will be capable of resisting this applied load whilst others will allow the panel to move the full 15 mm immediately. The test should not influence this behaviour in any way either during or following the withdrawal of the bolt.

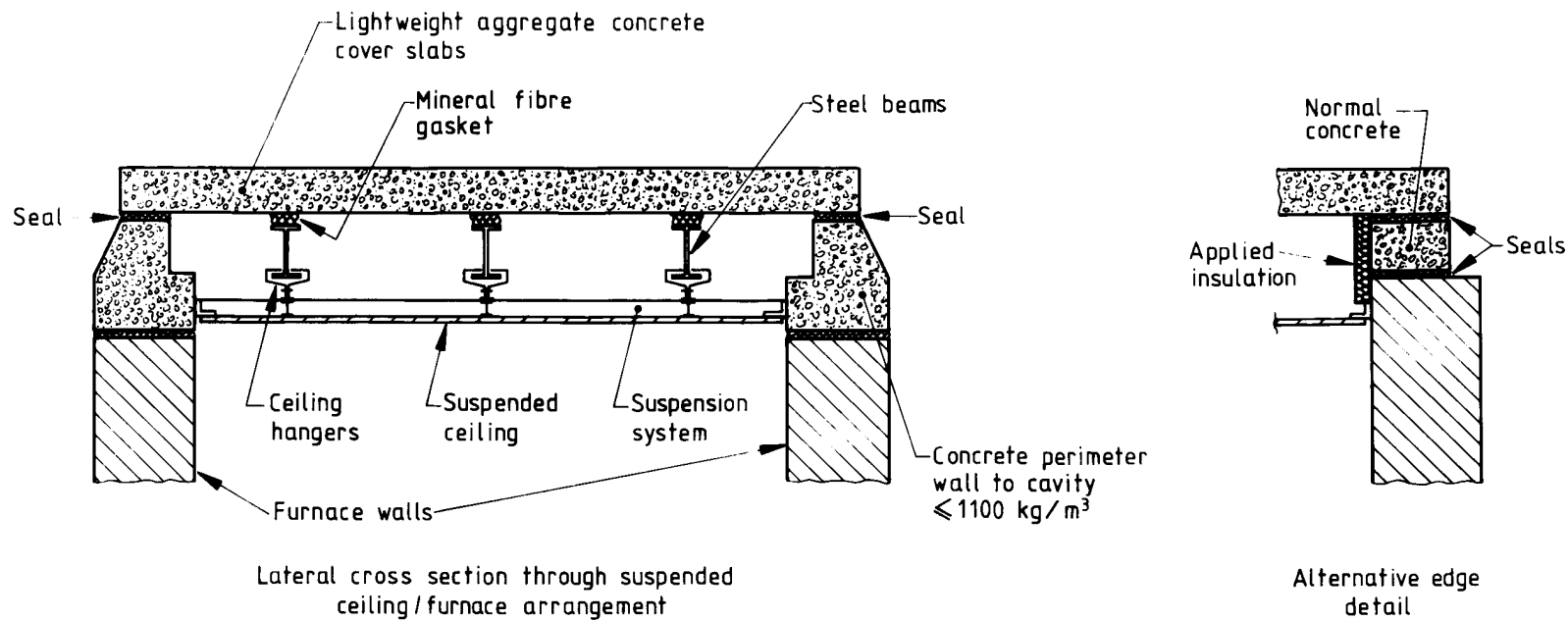

(a) Lateral cross section through suspended ceiling/furnace arrangement

(b) Alternative edges detail

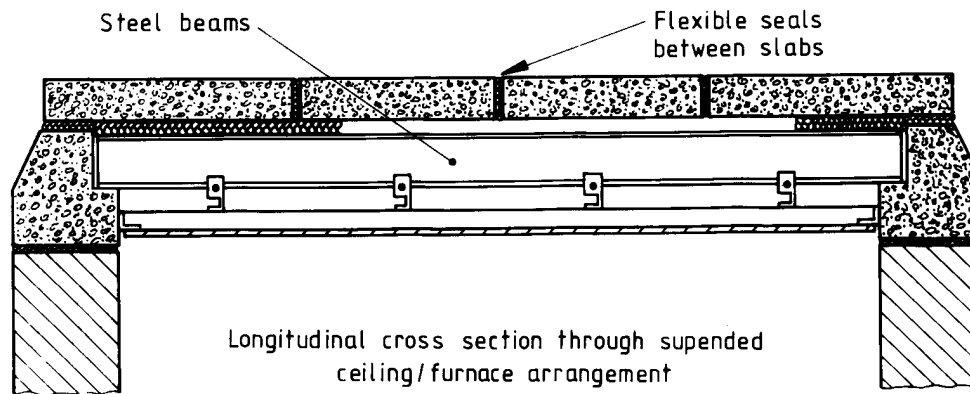

(c) Longitudinal cross section through suspended ceiling/furnace arrangement

Figure 1 — Non-loaded suspended ceiling test assembly

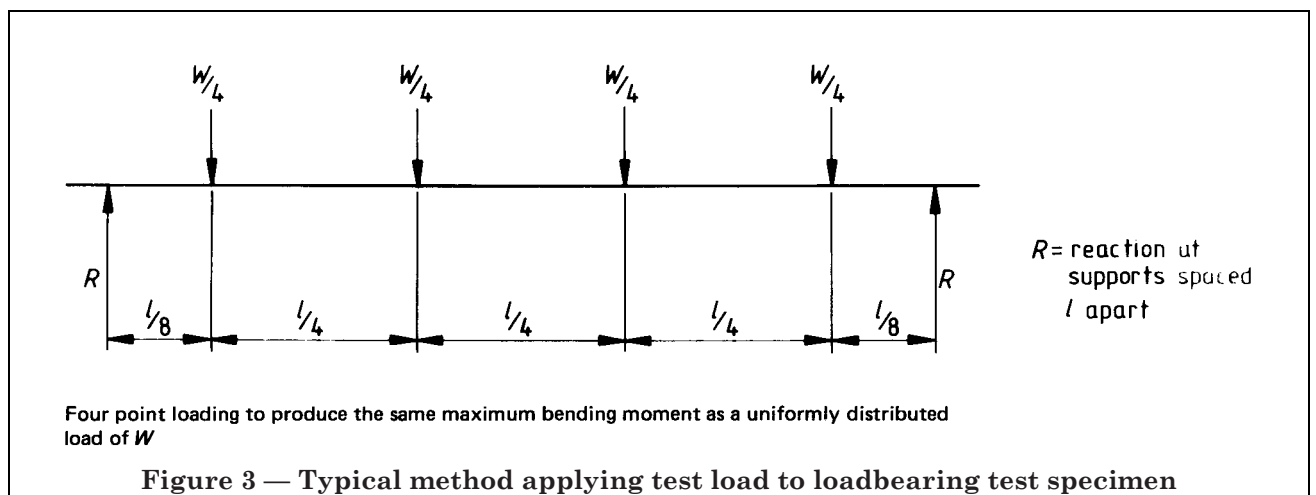
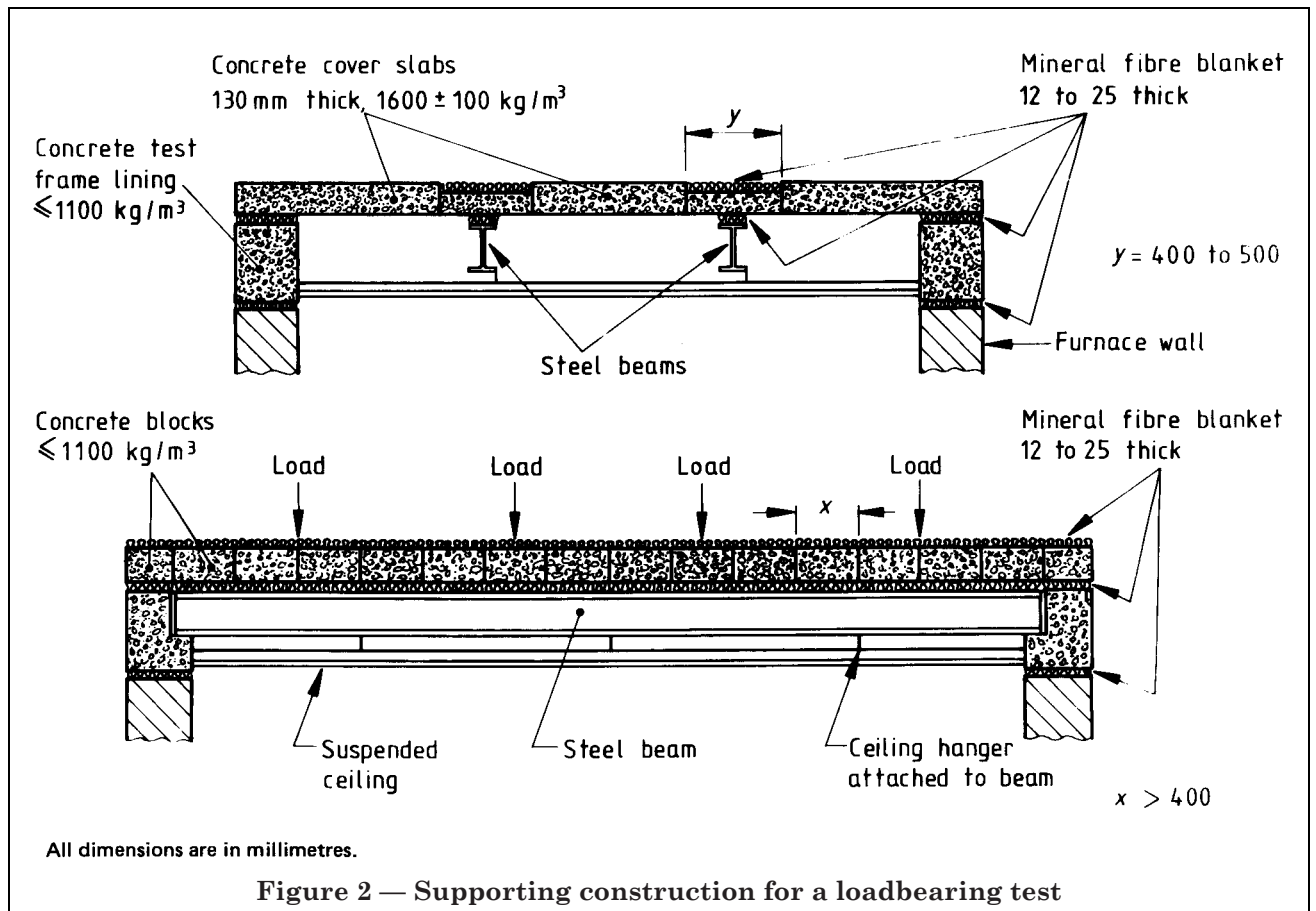

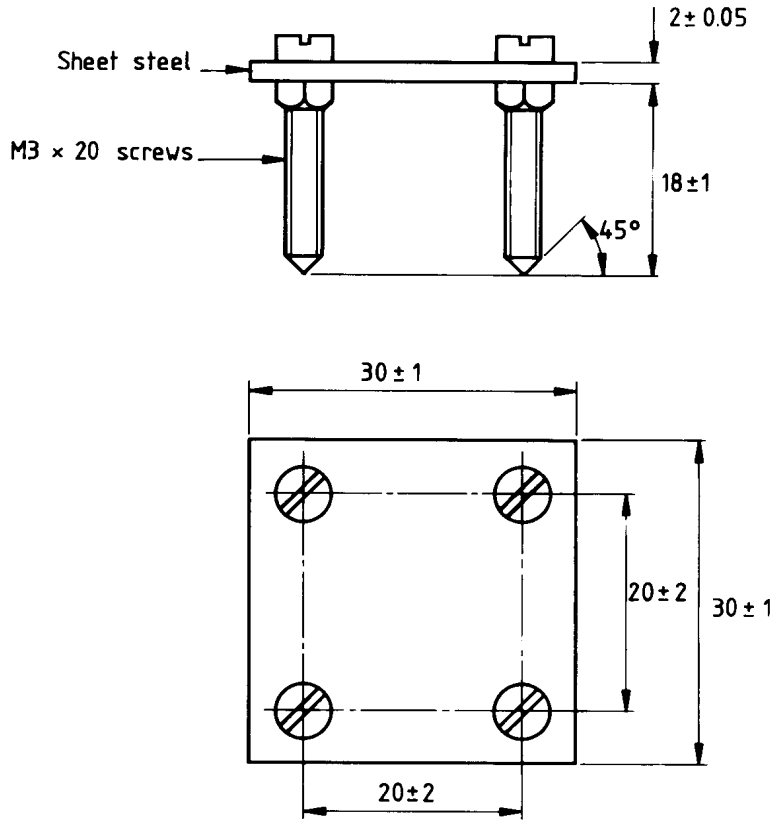

All dimensions are in millimetres.

Figure 4 — Thermocouple weight

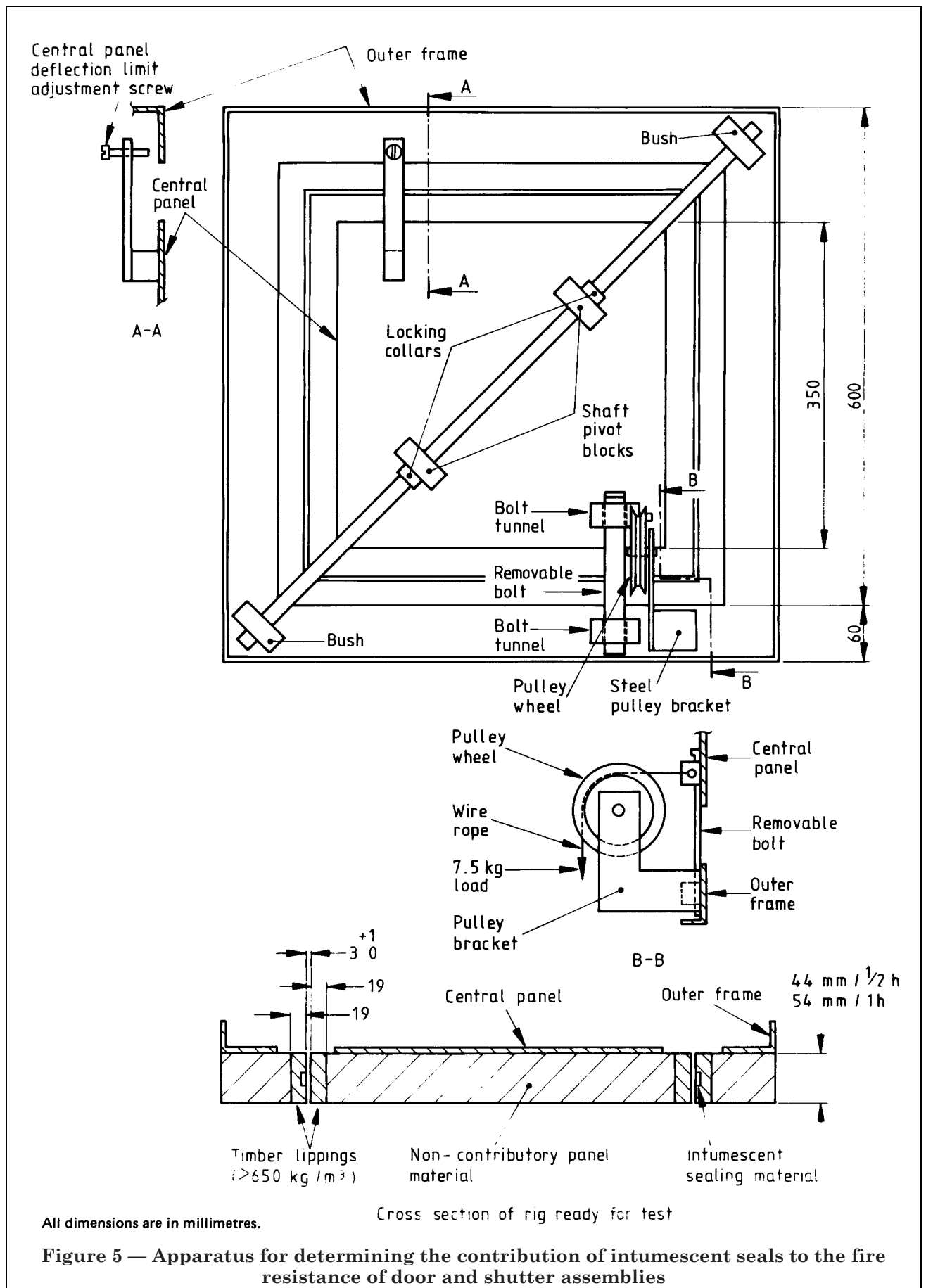

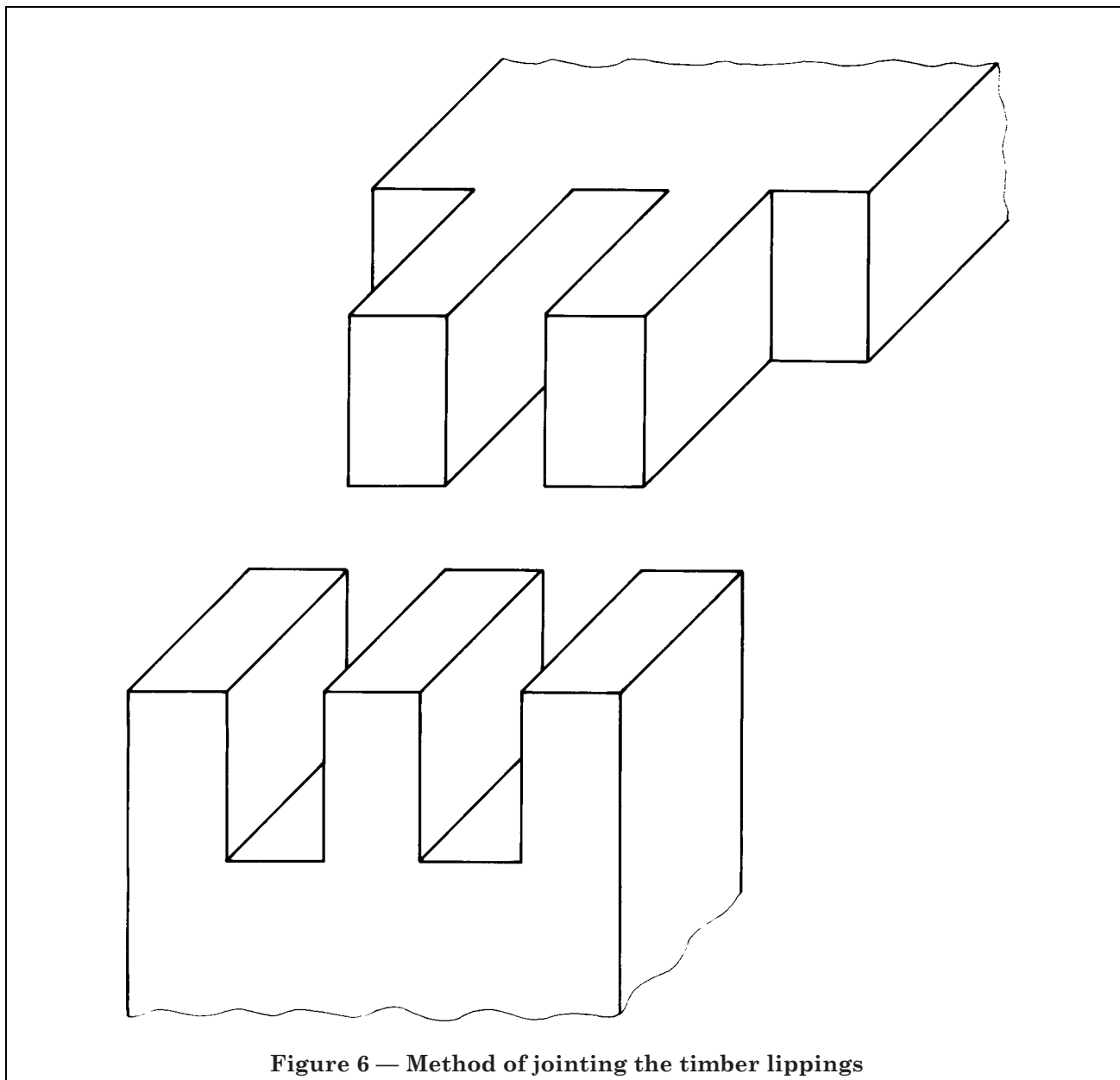

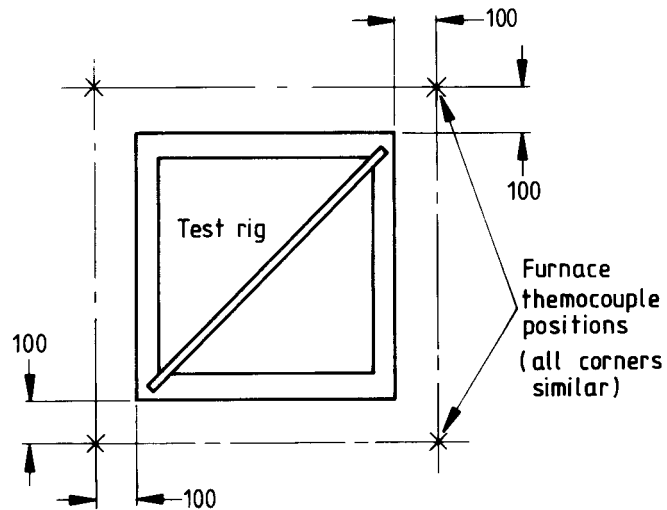

(a) Thermocouple positions when testing one rig

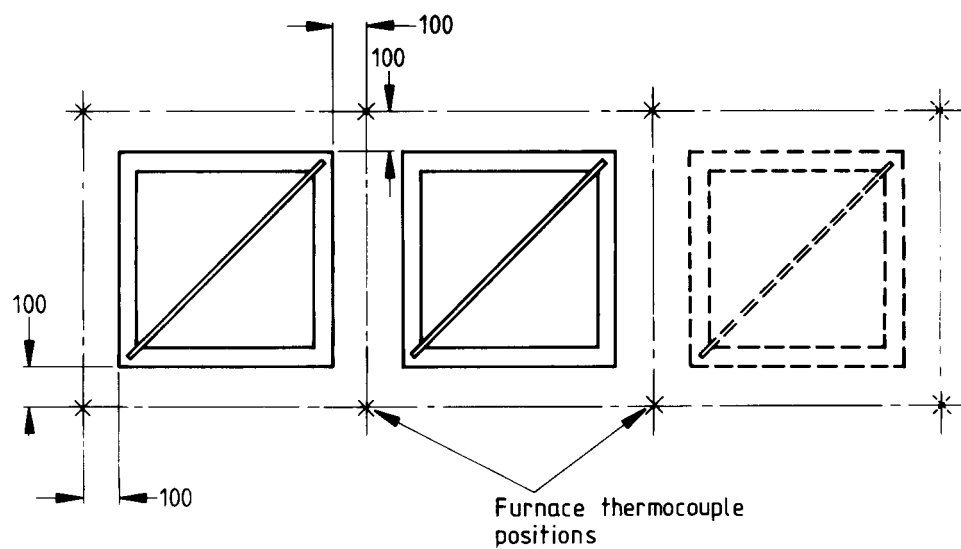

(b) Thermocouple positions when testing two or more rigs

All dimensions are in millimetres.

Figure 7 — Thermocouple arrangements to be used when determining the contribution made by intumescent seals

Mineral fibre blanket to inhibit
connective heat loss from cavity
(12 to 25 mm thick, medium density)

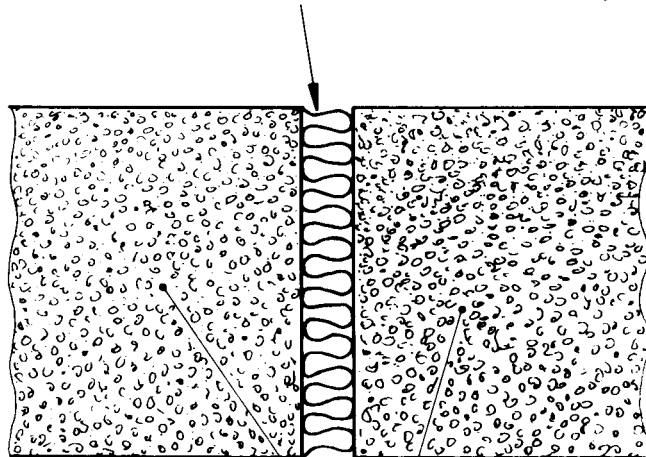

Adjacent cover slabs

Figure 8 — Typical method for sealing joints between cover slabs

Publications referred to

BS 476, *Fire tests on building materials and structures.*

BS 476-20, *Method for determination of the fire resistance of elements of construction (general principles).*

BS 476-21, *Methods for determination of the fire resistance of loadbearing elements of construction.*

BS 476-22, *Methods for determination of the fire resistance of non-loadbearing elements of construction.*

BS 476-24, *Method for determination of the fire resistance of ventilation ducts.*

BS 4360, *Specification for weldable structural steels.*

BS 4422, *Glossary of terms associated with fire.*

BSI — British Standards Institution

BSI is the independent national body responsible for preparing British Standards. It presents the UK view on standards in Europe and at the international level. It is incorporated by Royal Charter.

Revisions

British Standards are updated by amendment or revision. Users of British Standards should make sure that they possess the latest amendments or editions.

It is the constant aim of BSI to improve the quality of our products and services. We would be grateful if anyone finding an inaccuracy or ambiguity while using this British Standard would inform the Secretary of the technical committee responsible, the identity of which can be found on the inside front cover. Tel: 020 8996 9000. Fax: 020 8996 7400.

BSI offers members an individual updating service called PLUS which ensures that subscribers automatically receive the latest editions of standards.

Buying standards

Orders for all BSI, international and foreign standards publications should be addressed to Customer Services. Tel: 020 8996 9001. Fax: 020 8996 7001.

In response to orders for international standards, it is BSI policy to supply the BSI implementation of those that have been published as British Standards, unless otherwise requested.

Information on standards

BSI provides a wide range of information on national, European and international standards through its Library and its Technical Help to Exporters Service. Various BSI electronic information services are also available which give details on all its products and services. Contact the Information Centre. Tel: 020 8996 7111. Fax: 020 8996 7048.

Subscribing members of BSI are kept up to date with standards developments and receive substantial discounts on the purchase price of standards. For details of these and other benefits contact Membership Administration. Tel: 020 8996 7002. Fax: 020 8996 7001.

Copyright

Copyright subsists in all BSI publications. BSI also holds the copyright, in the UK, of the publications of the international standardization bodies. Except as permitted under the Copyright, Designs and Patents Act 1988 no extract may be reproduced, stored in a retrieval system or transmitted in any form or by any means – electronic, photocopying, recording or otherwise – without prior written permission from BSI.

This does not preclude the free use, in the course of implementing the standard, of necessary details such as symbols, and size, type or grade designations. If these details are to be used for any other purpose than implementation then the prior written permission of BSI must be obtained.

If permission is granted, the terms may include royalty payments or a licensing agreement. Details and advice can be obtained from the Copyright Manager. Tel: 020 8996 7070.