

BRITISH STANDARD

Specification for cast iron drain pipes, fittings and their joints for socketed and socketless systems

ICS 23.040.10, 23.040.40, 91.140.80

BSi
British Standards

NO COPYING WITHOUT BSI PERMISSION EXCEPT AS PERMITTED BY COPYRIGHT LAW

Publishing and copyright information

The BSI copyright notice displayed in this document indicates when the document was last issued.

© BSI 2008

ISBN 978 0 580 57781 9

The following BSI references relate to the work on this standard:

Committee reference PSE/10

Draft for comment 08/30156969 DC

Publication history

First published February 1932

Second edition, June 1933

Third edition (as BS 437-1), November 1970

Fourth edition (as BS 437), October 1978

Fifth (present) edition, April 2008

Amendments issued since publication

Amd. no.	Date	Text affected
-----------------	-------------	----------------------

Contents

Foreword *ii*

- 1** Scope *1*
- 2** Normative references *1*
- 3** Terms and definitions *1*
- 4** Technical requirements *3*
- 5** Performance requirements for flexible joints *8*

Annexes

Annex A (normative) Test methods *9*

Bibliography *12*

List of figures

Figure 1 – Socket dimensions *4*

Figure 2 – Sealing zones for couplings *5*

Figure A.1 – Crush test apparatus for pipes *11*

List of tables

Table 1 – Dimensions of pipes and fittings *3*

Table 2 – Socket dimensions *4*

Table 3 – Sealing zone lengths *6*

Table 4 – Mechanical properties of pipes, fittings and couplings *6*

Summary of pages

This document comprises a front cover, an inside front cover, pages i and ii, pages 1 to 12, an inside back cover and a back cover.

Foreword

Publishing information

This British Standard is published by BSI and came into effect on 30 April 2008. It was prepared by Technical Committee PSE/10, *Iron pipes and fittings*. A list of organizations represented on this committee can be obtained on request to its secretary.

Supersession

This British Standard supersedes BS 437:1978+A1:1988, which is withdrawn.

Information about this document

This is a full revision of the standard, which now includes:

- a) performance requirements for the joints, based on the requirements of BS EN 877;
- b) socketless fittings not previously covered in BS 437;
- c) ductile iron couplings for jointing socketless systems.

The revision takes account of changes to the foundry practice concerned with the making of cast iron drain goods.

Presentational conventions

The provisions of this standard are presented in roman (i.e. upright) type. Its requirements are expressed in sentences in which the principal auxiliary verb is “shall”.

Commentary, explanation and general informative material is presented in smaller italic type, and does not constitute a normative element.

Requirements in this standard are drafted in accordance with *The BSI guide to standardization – Section 2: Rules for the structure, drafting and presentation of British Standards*, subclause **11.3.1**, which states, “Requirements should be expressed using wording such as: ‘When tested as described in Annex A, the product shall ...’”. This means that only those products that are capable of passing the specified test will be deemed to conform to this standard.

Contractual and legal considerations

This publication does not purport to include all the necessary provisions of a contract. Users are responsible for its correct application.

Compliance with a British Standard cannot confer immunity from legal obligations.

1 Scope

This British Standard specifies the requirements for cast iron drain systems for use in buried applications or suspended within a basement, in areas not subject to fire regulations, where any pressure likely to occur is a maximum of 3.5 bar.

NOTE In this standard, all pressures are relative pressures, expressed in bars (100 kPa = 1 bar).

The nominal sizes of the drain systems are DN 100, DN 150 and DN 225 inclusive.

The standard specifies the requirements for materials, dimensions and tolerances, mechanical properties and surface condition for cast iron pipes and fittings. It also indicates performance requirements for all components, including joints.

2 Normative references

The following referenced documents are indispensable for the application of this document. For dated references, only the edition cited applies. For undated references, the latest edition of the referenced document (including any amendments) applies.

BS EN 681-1, *Elastomeric seals – Material requirements for pipe joint seals used in water and drainage applications – Part 1: Vulcanized rubber*

BS EN 877, *Cast iron pipes and fittings, their joints and accessories for the evacuation of water from buildings – Requirements, test methods and quality assurance*

3 Terms and definitions

For the purposes of this British Standard the following terms and definitions apply.

3.1 cast iron

alloy of iron and carbon in which graphite can be present in different forms

NOTE In grey cast iron the graphite is in flake form; in ductile iron it is formed as nodules.

3.2 coupling

connecting piece used to join together the spigots of mating pipes or fittings

3.3 drain

system of pipes, fittings and joints which will be buried in the ground or suspended within basements, in order to connect the discharge system of the building to a sewer or septic tank

3.4 fitting

cast iron component, other than a pipe, which allows deviation, a change in direction or diameter, including access components

3.5 flexible joint

joint which permits significant angular deflection both during and after installation and which can accept a slight offset of the centreline

3.6 gasket

elastomeric sealing component of a joint

3.7 joint

connection between the ends of pipes and/or fittings using various methods of sealing including socket/spigot or coupling, with sealing effected by elastomeric gasket(s) or sealing compounds

3.8 joint assembly

two spigots or a socket and spigot and means of joining them together, assembled into a single unit

3.9 length

effective length of a pipe or fitting

NOTE For socket and spigot pipes and fittings, the effective length is equal to the overall length minus the spigot insertion depth as given in the manufacturer's catalogues.

3.10 nominal size (DN)

alphanumeric designation, used for reference purposes, of the size of components and pipework system comprising the letters DN followed by a dimensionless whole number which is indirectly related to the physical size, in millimetres, of the bore or outside diameter of the end connections

[BS EN ISO 6708:1996, 2.1]

NOTE In this standard it is the bore.

3.11 pipe

casting of uniform bore, straight in axis, normally having plain ends but can also be socketed

3.12 rigid joint

joint that does not permit significant angular deflection either during or after installation

3.13 sewer

system of pipes designed to collect surface water and waste water from buildings and convey them to the point of disposal or treatment

3.14 type test

proof of design test which is carried out once to demonstrate compliance with the requirements of this standard and which is repeated only after significant change in manufacture, design or material

3.15 waste water

water which is contaminated by use and all water discharging into the drainage system, e.g. domestic and trade effluent, condensate water and rainwater when discharged into a waste drainage system

4 Technical requirements

4.1 General

The requirements for pipes, fittings and joints are defined in 4.2 to 4.8.

4.2 Surface condition

When inspected in accordance with A.1, pipes and fittings shall be free from defects (superficial and other defects) which could be detrimental to their correct operation as defined in this standard.

4.3 Dimensions

4.3.1 Nominal size

The nominal sizes shall be DN 100, DN 150 and DN 225.

4.3.2 External diameter (DE)

The standard external diameters (DE) of the coated spigot ends of pipes and fittings, as well as the tolerances applicable to these, shall conform to the values given in Table 1, when measured in accordance with A.2.

Table 1 **Dimensions of pipes and fittings**

Dimensions in millimetres

DN	External diameter DE		Min. wall thickness
	Nominal value	Tolerance	
100	117	+2 -1	6.7
150	171	+2 -1	7.7
225	254	+2 -2	10.2

In addition, the ovality of the pipes and of the sealing zones of fittings (see 4.3.9) shall remain within the tolerances on DE shown in Table 1.

4.3.3 Internal diameter of pipes

When measured in accordance with A.3, the internal diameter in millimetres (mm) of pipes shall be not less than (DN – 1) mm.

NOTE The minimum internal diameter ensures the hydraulic function of the pipes.

4.3.4 Wall thickness

Wall thicknesses of pipes and fittings shall conform to the minimum values given in Table 1 when measured in accordance with A.4.

4.3.5 Socket dimensions for rigid joints

Sockets for rigid joints shall conform to the dimensions given in Figure 1 and Table 2 when measured in accordance with A.5. Socket profiles might vary from manufacturer to manufacturer but shall conform to the minimum dimensions given in Table 2.

Figure 1 **Socket dimensions**

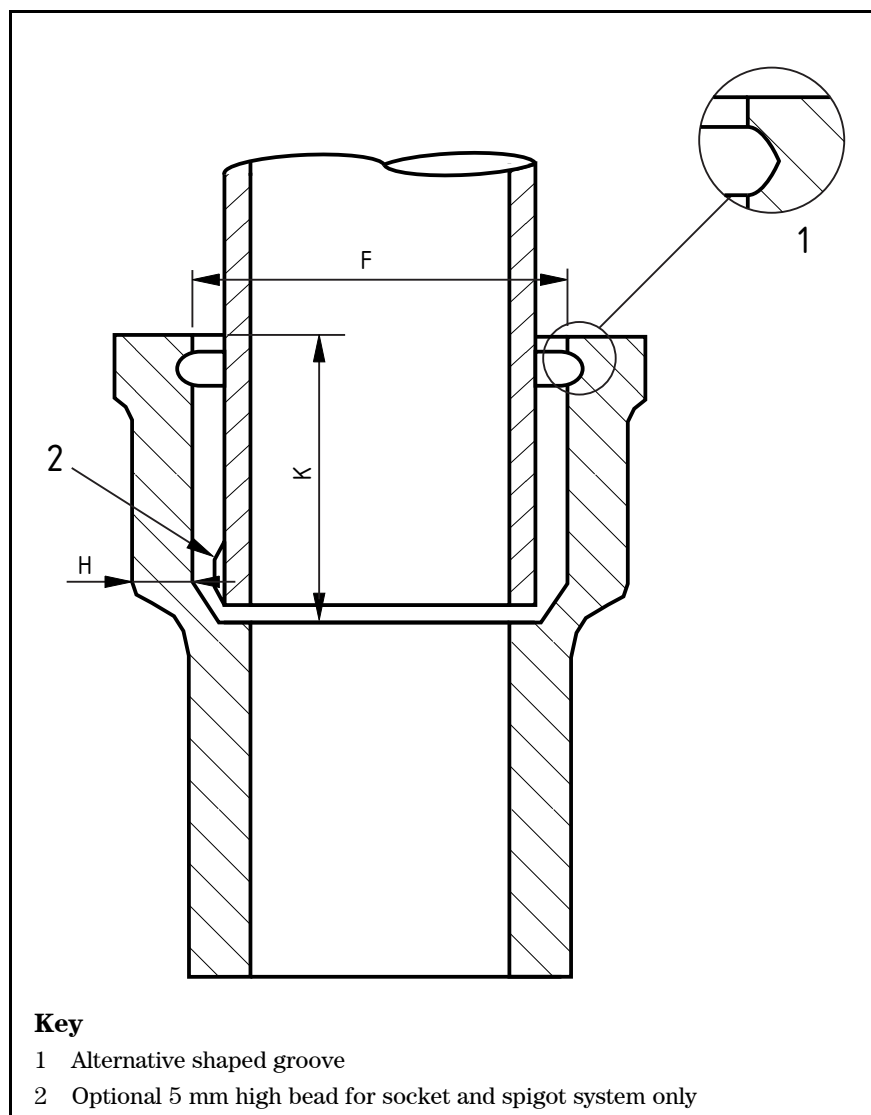

Table 2 **Socket dimensions**
Dimensions in millimetres

Socket dimension		DN		
		100	150	225
Minimum internal diameter	F	136	190	276
Minimum thickness	H	14	14	17
Minimum depth of socket	K	75	90	115

4.3.6 Straightness of pipes

When measured in accordance with **A.6**, the pipes shall be straight with a maximum deviation of 0.15% of their length.

4.3.7 End faces

The end faces of the products shall be free from defects which might impair their fitness for use and their planes shall be perpendicular with the axes of symmetry of the products. When measured in accordance with **A.7**, the maximum deviation from the right angle shall be 3°.

4.3.8 Length of pipes

Standard pipes shall be produced with a length of 3 m. When measured in accordance with **A.8**, the length shall be within a tolerance of ± 20 mm.

NOTE Other lengths are available.

4.3.9 Length of fittings and sealing zones/socket depths

The length of fittings shall be given in the manufacturer's catalogue. When measured in accordance with **A.8** the lengths of fittings shall be within a tolerance of ± 5 mm.

The ends of the fittings shall have sealing zones straight in axis (see Figure 2) and free from markings and defects which could impair their fitness for use.

The length of the socket insertion depth (Figure 1, dimension K) and the sealing zone (Figure 2, dimension J) shall conform to the values given in Table 2 and Table 3 respectively.

Figure 2 Sealing zones for couplings

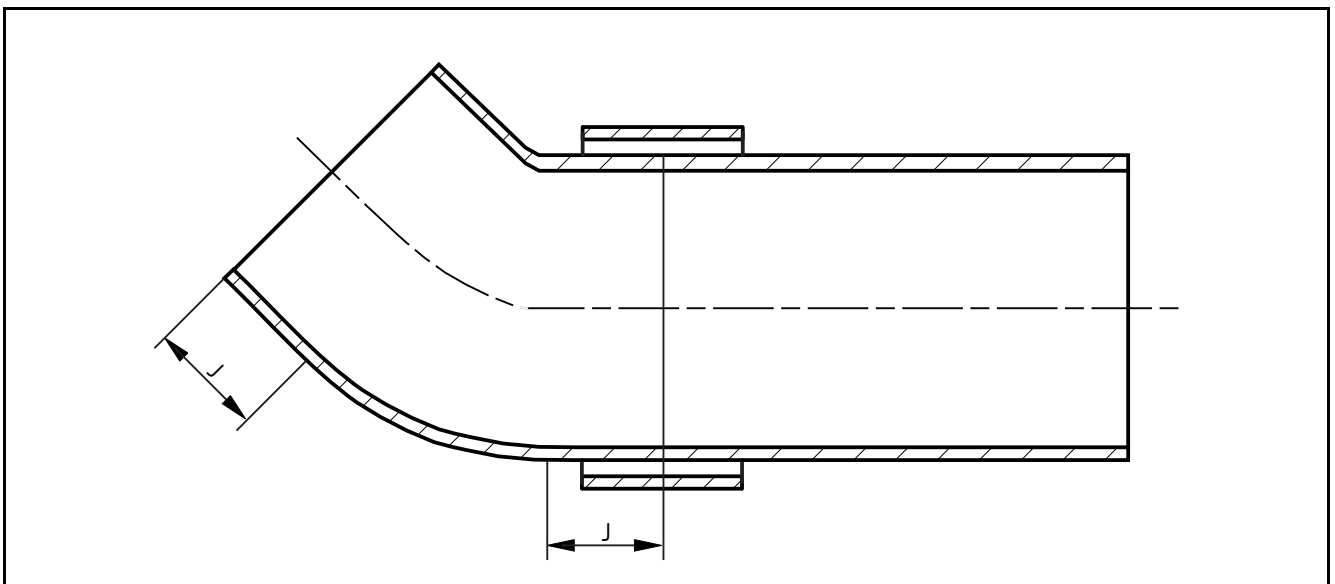

Table 3 Sealing zone lengths

DN	Min. length of sealing zone, J mm
100	40
150	40
225	55

4.3.10 Angles of fittings

Fittings shall be designed to the angles specified below with a design tolerance of $\pm 2^\circ$:

- bends: 10° , 22.5° , 35° , 45° , 60° , 67.5° , 80° , 87.5° ;
- branches: 45° , 67.5° , 87.5° .

The angle(s) of fittings shall be determined to an accuracy of $30'$.

4.3.11 Access components and traps

The minimum dimension of the openings of access components shall be not less than the minimum internal diameter of the fitting.

The height of water seal of traps shall be at least 50 mm.

4.4 Mass

The nominal mass of finished products (pipes and fittings) shall be given in the manufacturer's catalogues. When the mass is measured in accordance with A.9, the lower deviation shall not exceed 15% of the nominal mass.

4.5 Material characteristics of pipes and fittings

Pipes and fittings shall be manufactured from grey cast iron in accordance with BS EN 877.

Couplings shall be manufactured from ductile iron in accordance with BS EN 877.

Mechanical properties shall be as given in Table 4.

Table 4 Mechanical properties of pipes, fittings and couplings

Type of casting and material	Minimum tensile strength ^{A)} MPa	Crushing requirement ^{B)} kN/m	Maximum Brinell hardness, HBW ^{A)}
Pipes • grey cast iron	200	150	260
Fittings • grey cast iron	150	—	260
Couplings • ductile iron	420	—	250

A) When measured in accordance with BS EN 877.

B) When measured in accordance with A.10.

4.6 Coatings for pipes, fittings and couplings

The cast iron components shall be supplied coated internally and externally. Before applying the coatings the surfaces shall be dry and free from rust or non-adhering products or foreign matter, e.g. oil, grease.

NOTE Points of contact inherent in the coating application system are permitted.

Various coatings are available and the manufacturer shall state in his catalogue his coating options for both buried and suspended systems.

4.7 Joints

4.7.1 General

Joints shall permit an air and watertight connection between the ends of pipes and/or fittings.

Rigid joints, usually socket and spigot, shall use a cold caulking jointing compound and ensure leak tightness in accordance with Clause 5.

Flexible joints shall incorporate an elastomeric gasket (see 4.7.2.2) to ensure leak tightness, and, for couplings, to prevent direct contact between the ends of pipes/fittings. Flexible joints shall fulfil the leak tightness performance requirements of Clause 5.

4.7.2 Flexible joint materials

4.7.2.1 Couplings

Couplings shall be made in accordance with BS EN 877.

Cast iron couplings shall be coated as fittings in accordance with 4.6.

For steel set screws and nuts the minimum strength class shall be in accordance with BS EN 877.

4.7.2.2 Gaskets

The elastomeric gasket shall conform to the requirements of BS EN 681-1 for type WC.

4.8 Marking

Pipes, fittings and couplings shall be legibly and indelibly marked and shall bear at least the following information.

- Manufacturer's name or mark.
- The identification of the production site.
- The period of manufacture, coded or not.
- The reference to this standard.
- The DN, or several DN where applicable.
- The design angle of fittings where applicable.

When the marking on the fittings is cast-on, it shall be located outside the sealing zone J, see Table 3.

When the dimensions of the component do not permit full marking, an abbreviated marking providing identification of the component shall be used.

5 Performance requirements for flexible joints

5.1 General

In order to ensure their fitness for purpose, all flexible joints shall fulfil the performance requirements of Clause 5.

There shall be a type test for at least one DN.

All joints shall be fully flexible and the angular deflection declared by the manufacturer shall be not less than:

- 3° for DN 100 and DN 150;
- 1° 45' for DN 225.

5.2 Test conditions

All flexible joints shall be type tested as follows:

- a) joint assembly aligned withdrawn and pressurized in accordance with BS EN 877;
- b) joint assembly deflected and pressurized in accordance with BS EN 877;
- c) joint assembly sheared and pressurized in accordance with BS EN 877.

The joints shall exhibit no visible leakage and show no detrimental damage.

All rigid joints shall be type tested as a) for flexible joints and shall show no visible sign of leakage when subjected to a 2 bar hydrostatic test pressure.

Annex A (normative) Test methods

A.1 Surface condition

Inspect the surface condition (see 4.2) of the finished products (internal and external) visually.

A.2 External diameter (DE)

Measure the external diameter of spigots on coated pipes and fittings, by means of a circumferential tape or controlled by pass-fail gauges. In addition, visually inspect them for conformity to the spigot allowable ovality (4.3.2) and, in case of doubt; measure the maximum and minimum spigot axes using suitable equipment or control it using pass/fail gauges.

A.3 Internal diameter

In general the internal diameter need not be measured and conformity to 4.3.3 is demonstrated by calculation from the measurements taken for the external diameter and the wall thickness of pipes (see A.2 and A.4), e.g. $117 - (2 \times 6.7) = 103.6$, i.e. in conformity with 4.3.3 where minimum requirement is: $100 - 1 = 99$.

A.4 Wall thickness

Pipe and fittings wall thickness compliance can be demonstrated by the manufacturer by a combination of various means, e.g.:

- direct wall thickness measurement;
- mechanical measurement;
- ultrasonic measurement.

Measurements are taken using suitable equipment having an error limit ± 0.1 mm.

A.5 Socket dimensions

Measure socket dimensions using suitable equipment or control it using a system of pass/fail gauges.

A.6 Straightness of pipes

Roll the pipe on two gantries or rotate it around its axis on rollers, which in each case are separated by not less than two-thirds of the pipe length. Determine the point of maximum deviation from the straight axis.

A.7 End faces

Measure the perpendicularity of the planes of the end faces with the axes of symmetry of the products by appropriate equipment to an accuracy of 30'.

A.8 Lengths

Measure the lengths of pipes, fittings and of the sealing zones/depth of sockets with suitable equipment to an accuracy of 1 mm, preceded by the test in accordance with A.7.

A.9 Mass

Check the masses of the finished products by weighing to an accuracy of within:

- 0.01 kg for masses up to 1 kg;
- 0.1 kg for masses greater than 1 kg up to 20 kg;
- 0.5 kg for masses greater than 20 kg up to 100 kg;
- 1.0 kg for masses greater than 100 kg.

A.10 Crushing test

A.10.1 Principle

A section of pipe is crushed using the load specified in Table 4.

A.10.2 Apparatus

A.10.2.1 Machine, capable of applying the load specified in Table 4 by way of bearing beams to upper and lower press blocks. The arrangement (see Figure A.1) is such that the load is applied in a vertical plane through the longitudinal centre lines of bearing and pipe.

A.10.2.2 Bearing beams, metal at least 150 mm wide and 305 mm long.

A.10.2.3 Upper press block, flat metal or hard wood 25 mm wide and 305 mm long faced with rubber 15 mm thick having a hardness between 50/60 IRHD.

A.10.2.4 Lower press block, a metal or hardwood V-shaped support having an included angle of 150°, minimum total width of 150 mm and a length of at least 305 mm faced with rubber 15 mm thick having a hardness between 50/60 IRHD.

A.10.3 Preparation of test pieces

Cut a straight section 300 mm \pm 5 mm long from the pipe to be tested such that the ends of the test pieces are without bead or socket and are at right angles to the axis of the piece.

A.10.4 Procedure

Apply the proof crushing load specified in Table 4 evenly and continuously at such a rate that the proof load is reached in between 30 s and 60 s.

Sustain the proof load for 30 s.

A.10.5 Results

If the section of pipe sustains the proof load requirements without fracture the test result is recorded as a PASS; if the section of pipe fractures the test result is recorded as a FAIL.

Figure A.1 Crush test apparatus for pipes

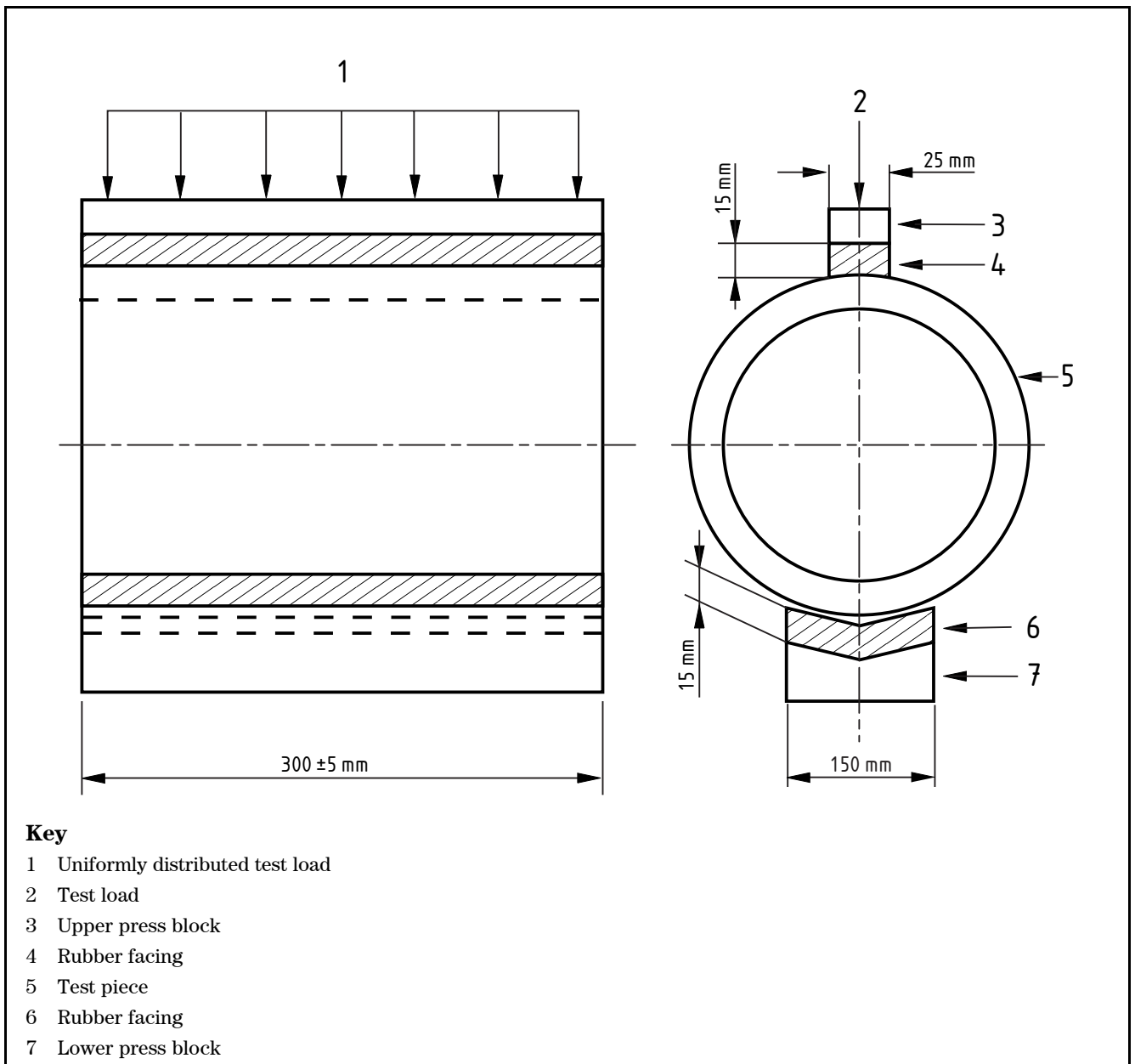

Bibliography

Standards publications

For dated references, only the edition cited applies. For undated references, the latest edition of the referenced document (including any amendments) applies.

BS EN ISO 6708:1996, *Pipework components – Definition and selection of DN (nominal size)*

Further information

BS 416-1, *Discharge and ventilating pipes and fittings, sand-cast or spun in cast iron – Part 1: Specification for spigot and socket systems*

BS EN 752 (all parts), *Drain and sewer systems outside buildings*

BS EN 12056 (all parts), *Gravity drainage systems inside buildings*

BSI – British Standards Institution

BSI is the independent national body responsible for preparing British Standards. It presents the UK view on standards in Europe and at the international level. It is incorporated by Royal Charter.

Revisions

British Standards are updated by amendment or revision. Users of British Standards should make sure that they possess the latest amendments or editions.

It is the constant aim of BSI to improve the quality of our products and services. We would be grateful if anyone finding an inaccuracy or ambiguity while using this British Standard would inform the Secretary of the technical committee responsible, the identity of which can be found on the inside front cover.

Tel: +44 (0)20 8996 9000. Fax: +44 (0)20 8996 7400.

BSI offers members an individual updating service called PLUS which ensures that subscribers automatically receive the latest editions of standards.

Buying standards

Orders for all BSI, international and foreign standards publications should be addressed to Customer Services. Tel: +44 (0)20 8996 9001.

Fax: +44 (0)20 8996 7001. Email: orders@bsi-global.com. Standards are also available from the BSI website at <http://www.bsi-global.com>.

In response to orders for international standards, it is BSI policy to supply the BSI implementation of those that have been published as British Standards, unless otherwise requested.

Information on standards

BSI provides a wide range of information on national, European and international standards through its Library and its Technical Help to Exporters Service. Various BSI electronic information services are also available which give details on all its products and services. Contact the Information Centre. Tel: +44 (0)20 8996 7111. Fax: +44 (0)20 8996 7048. Email: info@bsi-global.com.

Subscribing members of BSI are kept up to date with standards developments and receive substantial discounts on the purchase price of standards. For details of these and other benefits contact Membership Administration. Tel: +44 (0)20 8996 7002. Fax: +44 (0)20 8996 7001. Email: membership@bsi-global.com.

Information regarding online access to British Standards via British Standards Online can be found at <http://www.bsi-global.com/bsonline>.

Further information about BSI is available on the BSI website at <http://www.bsi-global.com>.

Copyright

Copyright subsists in all BSI publications. BSI also holds the copyright, in the UK, of the publications of the international standardization bodies. Except as permitted under the Copyright, Designs and Patents Act 1988 no extract may be reproduced, stored in a retrieval system or transmitted in any form or by any means – electronic, photocopying, recording or otherwise – without prior written permission from BSI.

This does not preclude the free use, in the course of implementing the standard, of necessary details such as symbols, and size, type or grade designations. If these details are to be used for any other purpose than implementation then the prior written permission of BSI must be obtained.

Details and advice can be obtained from the Copyright & Licensing Manager.

Tel: +44 (0)20 8996 7070. Fax: +44 (0)20 8996 7553.

Email: copyright@bsi-global.com.



389 Chiswick High Road
London
W4 4AL