

BS 376-1:2012



BSI Standards Publication

Railway signalling symbols

Part 1: Specification for schematic symbols

bsi.

...making excellence a habit.™

Publishing and copyright information

The BSI copyright notice displayed in this document indicates when the document was last issued.

© The British Standards Institution 2012

Published by BSI Standards Limited 2012

ISBN 978 0 580 74977 3

ICS 01.080.20; 45.020

The following BSI references relate to the work on this standard:

Committee reference GEL/9/1

Draft for comment 11/30244342 DC

Publication history

First published July 1951

Second (present) edition, July 2012

Amendments issued since publication

| Date | Text affected |
|-------------|----------------------|
|-------------|----------------------|

Contents

| | | |
|---|-----------------------|----|
| 1 | Scope | 1 |
| 2 | Terms and definitions | 1 |
| 3 | Signals | 1 |
| 4 | Points | 15 |
| 5 | Track details | 18 |
| 6 | Apparatus | 22 |
| 7 | Level crossings | 25 |
| 8 | Buildings | 30 |

Annexes

| | | |
|---------------------|--------------------------------|----|
| Annex A (normative) | Proportions for semaphore arms | 31 |
|---------------------|--------------------------------|----|

Bibliography

| | | |
|--|--|----|
| | | 32 |
|--|--|----|

List of figures

| | | |
|------------|--|----|
| Figure 1 | Colours of signal aspects and indicators | 1 |
| Figure A.1 | Semaphore arms | 31 |

List of tables

| | | |
|----------|---------------------------------|----|
| Table 1 | Colour light signals | 2 |
| Table 2 | Semaphore signals | 3 |
| Table 3 | Miscellaneous | 4 |
| Table 4 | Subsidiary and shunting signals | 5 |
| Table 5 | Indicators | 6 |
| Table 6 | Ancillary features | 8 |
| Table 7 | Signs | 10 |
| Table 8 | Signal structures | 14 |
| Table 9 | Points symbols | 15 |
| Table 10 | Train detection | 18 |
| Table 11 | Track features | 21 |
| Table 12 | Train warning and protection | 22 |
| Table 13 | Miscellaneous | 23 |
| Table 14 | Block and release apparatus | 24 |
| Table 15 | Level crossing | 25 |
| Table 16 | Traction | 29 |
| Table 17 | Building symbols | 30 |

Summary of pages

This document comprises a front cover, an inside front cover, pages i to ii, pages 1 to 32, an inside back cover and a back cover.

Foreword

Publishing information

This part of BS 376 is published by BSI and came into effect on 31 July 2012. It was prepared by Subcommittee GEL/9/1, *Signalling and communications*, under the authority of Technical Committee GEL/9, *Railway electrotechnical applications*. A list of organizations represented on this committee can be obtained on request to its secretary.

Supersession

This part of BS 376 supersedes BS 376-1:1951 (incorporating Amendment No.1:1951), which is withdrawn.

Relationship with other publications

BS 376 is issued in two parts, namely:

- BS 376-1, Schematic symbols

Part 1 is for use on general plans, showing signalling requirements; it does not show the component parts of the apparatus to be used.

- BS 367-2, Wiring symbols and written circuits

Part 2 represents:

- a) the actual apparatus used, with its electrical connections; and
- b) simplified wiring diagrams.

Information about this document

This is a full revision of the standard, updated to current practice.

Presentational conventions

The provisions of this standard are presented in roman (i.e. upright) type. Its requirements are expressed in sentences in which the principal auxiliary verb is "shall".

Commentary, explanation and general informative material is presented in smaller italic type, and does not constitute a normative element.

Contractual and legal considerations

This publication does not purport to include all the necessary provisions of a contract. Users are responsible for its correct application.

Compliance with a British Standard cannot confer immunity from legal obligations.

1 Scope

This British Standard specifies the symbols to be used on railway signalling plans but does not provide guidance on their application.

This British Standard does not apply to tramways operated on line of sight or using highway signals. It does not include proprietary systems and specialized applications.

NOTE 1 The symbols in this British Standard provide for apparatus in general use. They have been designed so that they can be combined together where one does not represent the complete device. In this British Standard, where certain elements are added for illustrative purposes, they are shown by dashed lines. If additional information is required to support the symbol, a “#” may be used to reference a note on the plan.

NOTE 2 The symbols are shown relative to the driver’s point of view; on actual plans the symbols are rotated.

NOTE 3 The size of symbols are drawn in proportion but are not necessarily relative to one another nor give specific size to use.

2 Terms and definitions

For the purposes of this part of BS 376, the following terms and definitions apply.





2.1 normal

display or position of a piece of apparatus in its quiescent state

3 Signals

The colours of signal aspects used in the symbols given in Table 1 shall conform to Figure 1. Where other colours are used, it shall be defined on the plan.

Figure 1 Colours of signal aspects and indicators

| | | | |
|--------------|---|---------------|---|
| a) Red (R) |  | b) Yellow (Y) |  |
| c) Green (G) |  | d) White (W) |  |

If other aspects than these are required, they shall be specified.

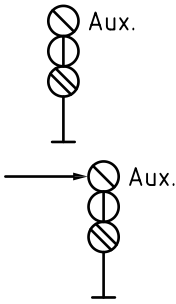
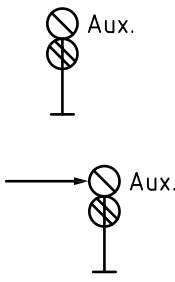


Where the normal aspect is required to be shown, the normal aspect shall be indicated by double lines.

Colour light signals shall be indicated on schematics with the symbols given in Table 1.

Table 1 Colour light signals

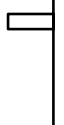

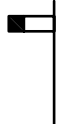
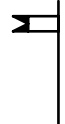


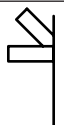
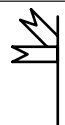
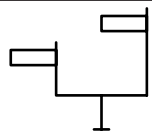
| Signal type | Symbol | | | |
|--|------------|---------------|----------------------|--------------|
| | Normal red | Normal yellow | Normal double yellow | Normal green |
| 1.1 Two aspect: Multi-unit | | | | |
| Single-unit searchlight | | | | |
| 1.2 Three aspect: Multi-unit | | | | |
| Single-unit searchlight | | | | |
| 1.3 Four aspect: Multi-unit | | | | |
| Fourth aspect used in conjunction with single-unit searchlight | | | | |
| 1.4 Example of approach lighting | | | | |
| 1.5 Aspect capable of flashing, e.g. double yellow | | | | |
| 1.6 Aspect not used, e.g. green not in use | | | | |
| 1.7 Splitting distant advance warning of junction: a) Divergence to left b) Equal speed routes c) Divergence to right | | | | |

Table 1 Colour light signals

| | | |
|---|---|---|
| <p>1.8 Auxiliary light</p> <p>Any aspect, also acting as an auxiliary</p> |  |  |
| <p>1.9 Slotted signals, colour light</p> |  |  |

Semaphore signals shall be indicated on schematics with the symbols given in Table 2. Proportions for semaphore arms shall be in accordance with Annex A.

Table 2 Semaphore signals



| Signal type | Stop signal | Distant signal |
|--|--|---|
| 2.1 Mechanical ordinary |  |  |
| 2.2 Power (all types) |  |  |
| 2.3 Fixed arm |  |  |
| 2.4 Slot |  |  |
| 2.5 Junction signal, e.g. divergence to left |  | |

Miscellaneous signals shall be indicated on schematics with the symbols given in Table 3.

Table 3 Miscellaneous

| Signal type | Symbol | |
|---|--------|----|
| 3.1 Reflectorized stop board, # is supplementary legend to be shown | | |
| 3.2 Reflectorized distant board | | |
| 3.3 Internally illuminated sign, # is supplementary legend to be shown | | |
| 3.4 Traction rail dead section: | | |
| a) Indicator | | |
| b) Repeater | | |
| 3.5 Banner signal | | |
| 3.6 Banner repeating signal: | | |
| a) Repeating stop signal (2 states) | | |
| b) Repeating stop signal (3 states, capable of showing green) | a) | b) |
| c) Repeating distant signal | | |
| d) Repeating stop signal (2 states), normally off | c) | d) |
| e) Repeating stop signal (3 states, capable of showing green), normally caution | | |
| f) Repeating stop signal (3 states, capable of showing green), normally clear | e) | f) |
| 3.7 Banner repeating signal, splitting, e.g. left-hand divergence (2 states) | | |

Table 3 Miscellaneous

| | |
|---|--|
| 3.8 Fog repeater |  |
| 3.9 Semaphore signal lamp-intensified light |  |

Subsidiary and shunting signals shall be indicated on schematics with the symbols given in Table 4.

Table 4 Subsidiary and shunting signals



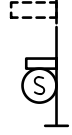

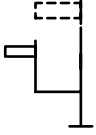








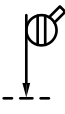

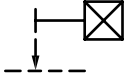

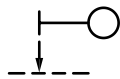
| Signal type | Symbol | | |
|---|---|--|---|
| <p>4.1 Position light, used with a main aspect, normally out:</p> <p>a) Subsidiary signal, steady aspect</p> <p>b) Subsidiary signal, capable of flashing, e.g. proceed on sight authority (PoSA)</p> |  |  | |
| <p>4.2 Subsidiary signal:</p> <p>a) Miniature arm ^{A), B)}</p> <p>b) Disc ^{A)}</p> <p>c) Offset miniature arm ^{C)}</p> |  |  |  |
| <p>4.3 Shunting signals, miniature arm:</p> <p>a) Dwarf signal ^{C)}</p> <p>b) e.g. three arms, bottom arm shown normally off ^{C)}</p> |  | |  |
| <p>4.4 Shunting signals, disc:</p> <p>a) Single (red)</p> <p>b) Single (yellow)</p> <p>c) Double</p> <p>d) Power operated</p> <p>e) External lighting</p> <p>f) Internal lighting</p> |  |  |  |
| <p>4.5 Shunting signals, position light:</p> <p>a) Normally on (red)</p> <p>b) Normally on (yellow)</p> <p>c) Normally off</p> |  |  |  |

Table 4 **Subsidiary and shunting signals**

| | | |
|---|---|---|
| <p>4.6 Shunting signals, slotted: a) Disc b) Position light</p> |  a) |  b) |
| <p>4.7 Limit of shunt a) Indicator b) Position light</p> |  a) |  b) |
| <p>4.8 Shunting, set back indicator, normally out, displays white when off, e.g. elevated head</p> |  | |

A) Where required, letter to be added to the symbol to identify route class is C for call on, S for shunt ahead and W for warning.
 B) The miniature arm has a horizontal band.
 C) The miniature arm has a vertical band.

Indicator signals shall be indicated on schematics with the symbols given in Table 5.

Table 5 **Indicators**


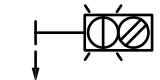
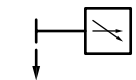


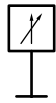











| Signal type | Symbol |
|--|--|
| <p>5.1 Point indicator: a) Mechanical b) Colour light c) Position indicator</p> |  a)  b)  c) |
| <p>5.2 Route indicator: a) Standard, # is number of indications b) Miniature, # is number of indications</p> |  a)  b) |
| <p>5.3 Preliminary route indicator (PRI), example shows indicator capable of showing straight route and divergence to right</p> |  |
| <p>5.4 Alphanumeric indicator ^{A)}: a) Example shows single-sided right away indicator b) Example shows double-sided off indicator</p> |  a)  b) |

Table 5 Indicators

| | |
|---|---|
| <p>5.5 Junction indicator for use with colour light:</p> <p>a) Example shows three divergences to the left</p> <p>b) Example shows divergences to the left and right</p> |  <p>a)</p>  <p>b)</p> |
| <p>5.6 Junction indicator repeater</p> |  |
| <p>5.7 Loading/unloading indicator</p> |  |
| <p>5.8 Driver's level crossing indicator</p> |  |
| <p>5.9 Signal passed at danger (SPAD) indicator</p> |  |
| <p>5.10 Carriage depot indicator with plunger, # is supplementary legend</p> |  |
| <p>5.11 Train protection and warning system (TPWS) lineside status indicator for radio electronic token block (RETB) lines</p> |  |
| <p>5.12 Combined stop board/TPWS indicator, # is supplementary legend</p> |  |

^{A)} This can indicate: TT - tripcock test, OFF - off, BT - brake test, BU - barriers up, RA - right away and CD - closed doors.

Ancillary features shall be indicated on schematics with the symbols given in Table 6.

Table 6 Ancillary features




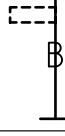




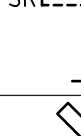
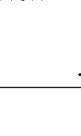



| Signal type | Symbol |
|--|---|
| 6.1 Signal not in use |   |
| 6.2 Signal, where the lever is electrically locked |  |
| 6.3 Signal, where the lever is released by block at "line clear" |  |
| 6.4 Signal, where the lever is released by token |  |
| 6.5 Signal, where the lever is interlocked with a key |  |
| 6.6 Arm electrically indicated in signal box |  |
| 6.7 Light electrically indicated in signal box |  |
| 6.8 Slot indicated in signal box |  |
| 6.9 Arm and slot, indicated in signal box |  |
| 6.10 Telephone: | |
| a) Direct to signaller |  |
| b) Direct to signaller, two-way ringing |  |
| c) Other, # is purpose, e.g. electrification control room (ECR) |  |
| | a) b) c) |

Table 6 Ancillary features

| | |
|---|---|
| <p>6.11 Signallers' facilities:</p> <p>a) Automatic signal, with replacement facilities from the signal box</p> <p>b) Controlled signal, with automatic working facility</p> <p>c) Single button controlled signal</p> | <div style="display: flex; justify-content: space-around; align-items: center;"> <div style="text-align: center;"> <p>Ⓜ</p> <p>a)</p> </div> <div style="text-align: center;"> <p>Ⓐ</p> <p>b)</p> </div> <div style="text-align: center;"> <p>Ⓢ</p> <p>c)</p> </div> </div> |
| <p>6.12 Signal notes:</p> <p>a) Last wheel replacement</p> <p>b) Controlled by level crossing gate box but supervised by main signal box</p> | <div style="display: flex; justify-content: space-around; align-items: center;"> <div style="text-align: center;"> <p>Ⓛ</p> <p>a)</p> </div> <div style="text-align: center;"> <p>ⓧ</p> <p>b)</p> </div> </div> |
| <p>6.14 Plunger or switch, # is function</p> | <div style="text-align: center;"> <p>⦿ #</p> </div> |
| <p>6.15 Pull cords or trip wires, # is length</p> | <div style="text-align: center;"> <p>— # —</p> </div> |

Signs shall be indicated on schematics with the symbols given in Table 7.

NOTE Signage on metrolight rail lines can be specific to local system requirements and therefore Table 7 might not apply.

Table 7 Signs

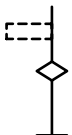
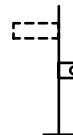
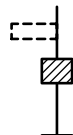






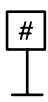

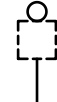




| Signal type | Symbol | | |
|--|---|--|---|
| 7.1 Signal post signs relating to driver-signaller communication a) Diamond sign b) D sign (call plunger) c) Telephone sign d) Automatic sign e) Semi-automatic sign f) Combined diamond and X sign (limited clearance) |  a) |  b) |  c) |
| |  d) |  e) |  f) |
| 7.2 Intermediate block (IB) home signal |  | | |
| 7.3 Level crossing, special speed restriction board, miniature, repeating, # is the speed |  | | |
| 7.4 Distant signal sign |  | | |
| 7.5 Notice board, # is wording to be stated: a) Reflective b) Externally illuminated c) Internally illuminated |  a) |  b) |  c) |
| 7.6 Block section markers ^{A)} : a) Fixed, European train control system (ETCS) b) Fixed (non-ETCS) c) Shunt |  a) |  b) |  c) |
| 7.7 Stop and proceed plate |  | | |

Table 7 Signs



















| | | |
|--|---|--|
| <p>7.8 Auxiliary signal: a) Capable of flashing b) Not capable of flashing</p> |  a) |  b) |
| <p>7.9 Hidden block section marker with red aspect, # refers to note identifying marker as illuminated</p> |  | |
| <p>7.10 Platform markers: a) Train stop marker, # is no. of cars b) Mid-platform train berth marker</p> |  a) |  b) |
| <p>7.11 Position markers: a) RETB loop clear marker b) Rear clear marker, e.g. neutral section</p> |  a) |  b) |
| <p>7.12 Automatic warning system (AWS) signs: a) AWS cancelling indicator b) AWS gap: 1) Commencement 2) Termination c) AWS special working 1) Commencement 2) Termination</p> |  a)  b) 1)  2)  c) 1)  2) | |
| <p>7.13 Cab signalling: a) Warning b) Commencement c) Termination</p> |  a) |  b)  c) |
| <p>7.14 Change of applicable operating rules, e.g. from NR to CTRL</p> |  | |
| <p>7.15 Radio system signs, # is channel number: a) Cab secure radio (CSR) b) National radio network (NRN)</p> |  a) |  b) |

Table 7 Signs





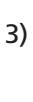
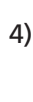


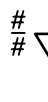



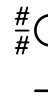




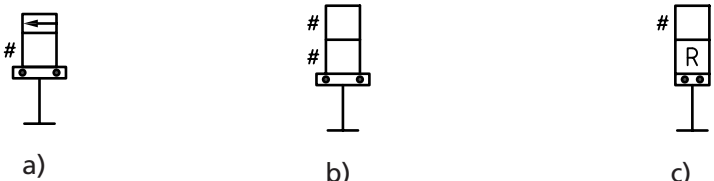




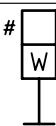
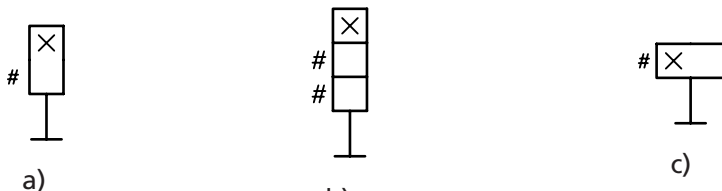
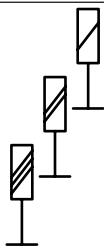

| | |
|---|---|
| <p>c) GSM-R equipped area: 1) Commencement 2) Termination 3) Interim Voice Radio System (IVRS) commencement 4) IVRS termination d) RETB</p> | <div style="display: flex; justify-content: space-around;"> <div style="text-align: center;"> <p>GSM-R</p>  </div> <div style="text-align: center;"> <p>IVRS</p>  </div> </div> <div style="display: flex; justify-content: space-around; margin-top: 20px;"> <div style="text-align: center;"> <p>c) 1) IVRS</p>  </div> <div style="text-align: center;"> <p>2) IVRS</p>  </div> </div> <div style="text-align: center; margin-top: 20px;"> <p>3)</p>  </div> <div style="text-align: center; margin-top: 20px;"> <p>4)</p>  </div> <div style="text-align: center; margin-top: 20px;"> <p>RETB</p> <p>#</p>  <p>d)</p> </div> |
| <p>7.16 Permissible speed warning indicator, # is speed: a) Directional arrow ^{A)} b) Standard differential speeds c) Non-standard differential speeds, to be designated on plan d) Miniature, for limited clearance or as repeater</p> | <div style="display: flex; justify-content: space-around; align-items: flex-start;"> <div style="text-align: center;">  <p>a)</p> </div> <div style="text-align: center;">  <p>b)</p> </div> <div style="text-align: center;">  <p>c)</p> </div> <div style="text-align: center;">  <p>d)</p> </div> </div> |
| <p>7.17 Permissible speed indicator, # is speed: a) With directional arrow ^{A)} b) Standard differential speeds c) Non-standard differential speeds, to be designated on plan d) Miniature, for limited clearance or as repeater</p> | <div style="display: flex; justify-content: space-around; align-items: flex-start;"> <div style="text-align: center;">  <p>a)</p> </div> <div style="text-align: center;">  <p>b)</p> </div> <div style="text-align: center;">  <p>c)</p> </div> <div style="text-align: center;">  <p>d)</p> </div> </div> |
| <p>7.18 Enhanced permissible speed (EPS) warning indicator, # is speed</p> | <div style="text-align: center;">  </div> |
| <p>7.19 EPS indicator, # is speed</p> | <div style="text-align: center;">  </div> |



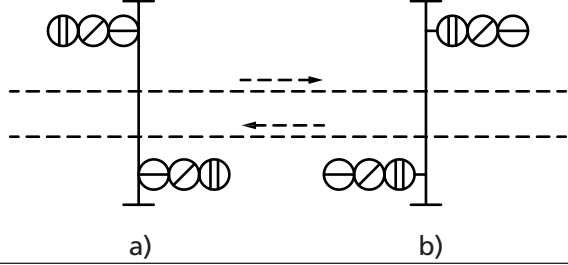
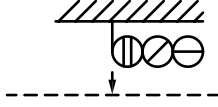

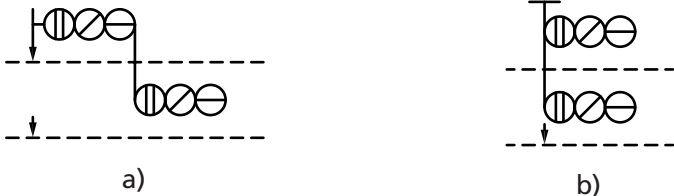

Table 7 Signs

| | |
|---|--|
| <p>7.20 Temporary speed restriction warning board, # is speed: a) With directional arrow ^{A)} b) Differential speeds c) Repeater</p> |  <p>a) b) c)</p> |
| <p>7.21 Emergency speed restriction warning indicator</p> |  |
| <p>7.22 Temporary speed restriction indicator, # is speed: a) With directional arrow ^{A)} b) Differential speeds c) Spate indicator (indicates published temporary speed restriction has been withdrawn) d) Termination</p> |  <p>a) b)</p> <p>c) d)</p> |
| <p>7.23 Advanced warning board for AOCL, ABCL, OC level crossings</p> |  |
| <p>7.24 Whistle board</p> |  |
| <p>7.25 Open level crossing, combined speed restriction/whistle board, # is speed</p> |  |
| <p>7.26 Automatic level crossing, speed restriction board, # is speed: a) Special (AOCL or ABCL) b) Differential speeds c) Wrong direction</p> |  <p>a) b) c)</p> |
| <p>7.27 Countdown markers</p> |  |
| <p>7.28 Signal reminder board, # is supplementary wording to be indicated on plan</p> |  |

^{A)} The arrow points towards the applicable line.

Signal structures shall be indicated on schematics with the symbols given in Table 8.

Table 8 Signal structures

| Symbol | Symbol |
|--|--|
| <p>8.1 Semaphore: a) Left-hand location b) Right-hand location</p> |  |
| <p>8.2 Colour light: a) Left-hand location b) Right-hand location</p> |  |
| <p>8.3 Colour light signal mounted on gantry spanning tracks: a) Suspended below b) Mounted above</p> |  |
| <p>8.4 Side fixing</p> |  |
| <p>8.5 Suspended fixing: a) Vertical b) Horizontal</p> |  |
| <p>8.6 Cantilever: a) Combined straight post and cantilever b) Two-track cantilever</p> |  |
| <p>8.7 Ground mounted</p> |  |

4 Points

Points shall be indicated on schematics with the symbols given in Table 9.

Where any function is operated by double wire, it shall be shown as "D/W".

Where worked from signal box or control point, controlling number shall be shown adjacent to the points.

Table 9 Points symbols



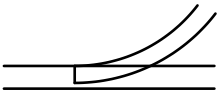
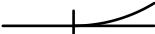
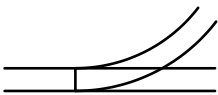

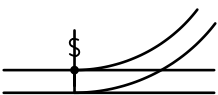

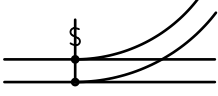
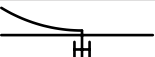

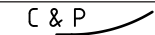
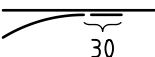
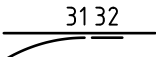
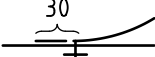
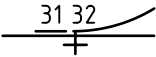
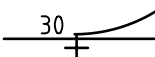
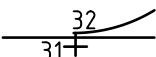

| Point | Symbol | | | |
|--|---|--|---|---|
| | Single line | Double line | | |
| 9.1 Normal lie of points where required to be shown: a) Right-hand switch normally closed b) Left-hand switch normally closed |  a) |   | | |
| 9.2 Points: a) Hand worked b) Spring 1-way c) Spring 2-way |  a) |   b) |   c) |  |
| 9.3 Hydro-pneumatic self-restoring, train operated |  | | | |
| 9.4 Worked by ground frame, ground panel or shunting frame ^{A), B)} |  | | | |
| 9.5 Clipped and padlocked "out of use" |  | | | |
| 9.6 Mechanically operated points, locks and bars ^{B)} : a) Without lock with bar (1-lever) b) Without lock with bar (2-levers) c) With lock and bar (1-lever) d) With lock and bar (2-levers) e) With lock without bar (1-lever) f) With lock without bar (2-levers) |  a) |  b) | | |
| |  c) |  d) | | |
| |  e) |  f) | | |
| 9.7 Clearance bar operated from signal box |  | | | |

Table 9 Points symbols

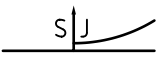





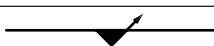

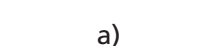

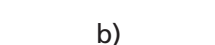
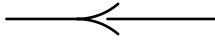
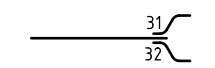








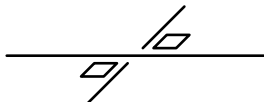
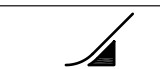




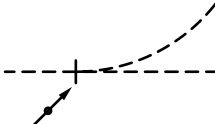
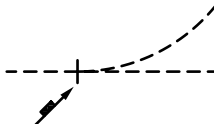

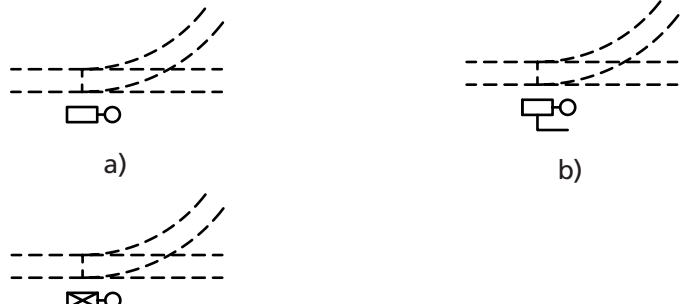

| | | |
|--|---|--|
| 9.8 Slotted joint control |  | |
| 9.9 Electrical detection of mechanically operated points |  | |
| 9.10 Ground track lock |  | |
| | Single line | Double line |
| 9.11 Scotch block |  |  |
| 9.12 Derailer [⊙] |  |  |
| 9.13 Trap: a) Single switch: 1) Without guard rail 2) With guard rail b) Double switch: 1) Without crossing 2) With crossing c) Wide to gauge: 1) With straight through route 2) Diverging points used as wide to gauge ^{B)} |   <p style="text-align: center;">a)</p>   <p style="text-align: center;">b)</p>  <p style="text-align: center;">c) 1)</p>  <p style="text-align: center;">c) 2)</p> |  <p style="text-align: center;">1)</p>  <p style="text-align: center;">2)</p>  <p style="text-align: center;">1)</p>  <p style="text-align: center;">2)</p>   |
| 9.14 Track circuit interrupter at trap or catch points |  |  |
| 9.15 Switch diamond |  | |
| 9.16 Swing nose crossing |  | |
| 9.17 Slip: a) Single b) Double |   <p style="text-align: center;">a)</p> |   <p style="text-align: center;">b)</p> |
| 9.18 Point releases by: a) Token b) Key on token |  <p style="text-align: center;">a)</p> |  <p style="text-align: center;">b)</p> |

Table 9 Points symbols

| | |
|--|--|
| <p>c) Key from signal box ^{B)} d) Key lock</p> |  <p style="text-align: center;">c) d)</p> |
| <p>9.19 Point operating mechanism: a) Power b) Lever/power dual control c) Trailable</p> |  <p style="text-align: center;">a) b)</p> <p style="text-align: center;">c)</p> |
| <p>9.20 Cabinet housing operating handle for manual operation</p> |  |

^{A)} A number shall be enclosed in a symbol specific to the control point (not a square or rectangle).

^{B)} The number shows the controlling lever.

^{C)} Arrows show direction of derailment.

5 Track details

Train detection shall be indicated on schematics with the symbols given in Table 10.

Table 10 Train detection

| Symbol type | Symbol | |
|---|-------------|-------------|
| | Single line | Double line |
| 10.1 Track circuit boundaries: | | |
| a) Track circuit in both directions | | |
| b) Track circuit on left, none on right | a) | |
| c) Track circuit on right, none on left | b) | c) |
| 10.2 Track circuit section: | | |
| a) Double rail section | | a) |
| b) Single rail section ^{A)} | | b) |
| 10.3 Short track section, # is length | | |
| 10.4 Gap, # is length | | |
| 10.5 Stainless steel welded strip, # is length | | |
| 10.6 Clearance point, joint A foul, joint B clear ^{B)} | | |
| 10.7 Overlap: | | |
| a) For signal on left | | |
| b) For signal on right | a) | b) |
| c) Where applicable to several signals, e.g. L2 and L3, and identification is required | c) | |
| d) Non-standard overlap length, # is length | c) | d) |
| 10.8 Restricted overlap for warning aspect and full overlap, # is overlap length | | |
| 10.9 Restricted and full phantom overlaps, # is effective overlap length | | |

Table 10 Train detection



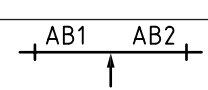


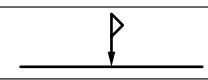

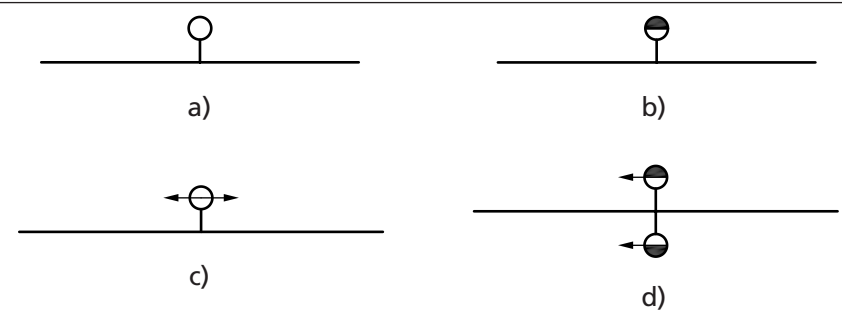
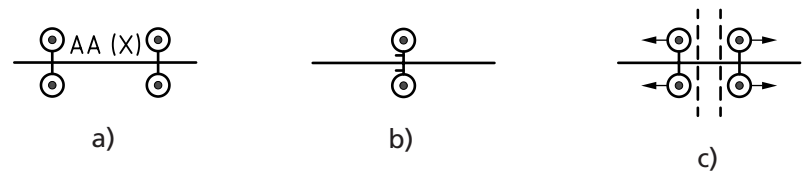

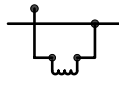
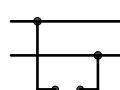
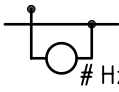
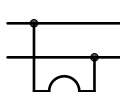
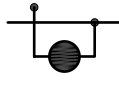
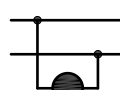
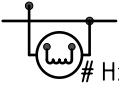

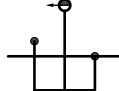
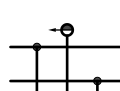
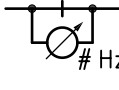
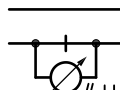
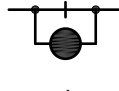
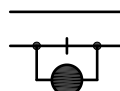
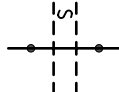
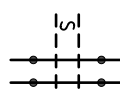
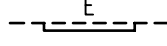
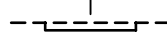
| | |
|---|---|
| <p>10.10 Block acceptance overlap (clearing point), # is effective overlap length:</p> <p>a) Co-incident with track circuit boundary</p> <p>b) Not co-incident</p> |  |
| <p>10.11 Bi-directional line:</p> <p>a) Common overlap joint for opposing signals</p> <p>b) Dimensioned, with signal numbers, # is overlap length</p> |  |
| <p>10.12 Track circuit, centre fed</p> |  |
| | <p style="text-align: center;">Single line Double line</p> |
| <p>10.13 Impedance bonds:</p> <p>a) With external tuning</p> <p>b) With internal tuning</p> |  |
| <p>10.14 Cascading or cut section in track circuit ^{C)}</p> |  |
| <p>10.15 Overlay rail circuit</p> |  |
| <p>10.16 Track circuit actuator interference detector (TCAID):</p> <p>a) Directional ^{D)}</p> <p>b) Non-directional ^{E)}</p> |  |
| <p>10.17 Treadle/position detector:</p> <p>a) Contacts normally open</p> <p>b) Contacts normally closed</p> <p>c) Operational both ways, independent contacts, e.g. normally open</p> <p>d) Operational one way, e.g. contacts normally closed, both rails</p> |  |
| <p>10.18 Axle counter:</p> <p>a) Counting in and out</p> <p>b) Example with overlap</p> <p>c) Arrow indicates effective direction of operation, example shows level crossing use</p> |  |
| | <p style="text-align: center;">Single line Double line</p> |
| <p>10.19 Level crossing predictors:</p> <p>a) Shunts, # is frequency:</p> <p>1) Hard wired</p> |  |

Table 10 Train detection

| | | |
|--|---|---|
| 2) Simulated track inductor |  <p>2)</p> |  |
| 3) Narrow band |  <p>3)</p> |  |
| 4) Wide band |  <p>4)</p> |  |
| 5) Narrow band with inductor |  <p>5)</p> |  |
| 6) Hard wired with directional treadle |  <p>6)</p> |  |
| b) Joint couplers, # is frequency: 1) Tuneable |  <p>b) 1)</p> |  |
| 2) Wide band shunt |  <p>2)</p> |  |
| c) Island track |  <p>c)</p> |  |
| 10.20 Depression bar, electrical: a) Independent b) Working with track circuit |  <p>a)</p> |  <p>b)</p> |

A) The insulated rail can be shown by a thicker line dependent on application.

B) Dimensions of critical clearance points to be identified on plan.

C) The arrow indicates the direction of control.

D) Detects in the direction of the arrow.

E) Detects in both directions.

Track features shall be indicated on schematics with the symbols given in Table 11.

Table 11 Track features

| Symbol type | Symbol | |
|---|-------------|-------------|
| 11.1 Distance marker, # is nominal distance | | |
| a) Mile post | a) | b) |
| b) Kilometre post | | |
| 11.2 Gradient posts ^{A)} | | |
| 11.3 Token apparatus: | | |
| a) Receiver | | |
| b) Deliverer | | |
| c) Exchanger | | |
| 11.4 Wagon retarder | | |
| 11.5 Turntable | | |
| 11.6 Traverser over 3 tracks | | |
| 11.7 Buffer stop: | | |
| a) No light | | |
| b) White light | a) | b) |
| c) Red light | | |
| d) Friction with track circuit interrupter | c) | d) |
| | Single line | Double line |
| 11.8 Sand drag, # is length: | | |
| a) Sanded track | a) | |
| b) With buffer stop | b) | |
| c) Sand hump | c) | |
| d) With red light | d) | |

^{A)} Upper figures show lengths for unit rise or fall. Alternatively, the lower figures, which show percentage values, might be used.

6 Apparatus

Train warning and protection shall be indicated on schematics with the symbols given in Table 12.

Table 12 Train warning and protection

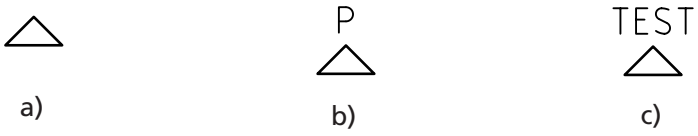
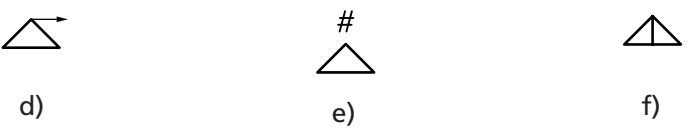


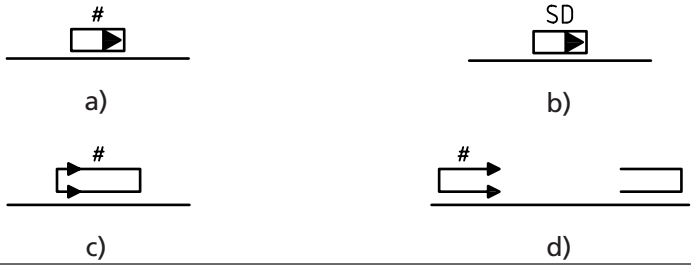


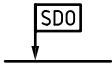
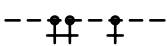

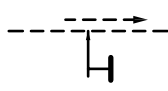
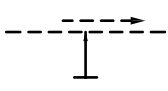
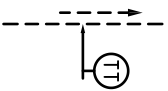
| Symbol type | Symbol |
|--|---|
| 12.1 Automatic warning system (AWS): a) Magnet, effective for direction of line only b) Permanent magnet only c) Depot test magnet d) Effective for movement in direction shown, suppressed for opposing moves e) Non-standard distance, # is distance to signal f) Selected suppression for normal direction of traffic g) One installation on bi-directional line effective in both directions, non-standard distances, # is signal number(s) and distance(s) as necessary h) Portable magnet |    |
| 12.2 Track-train data transmitter: a) Arrow indicates direction of travel b) Infill transmission limits |  |
| 12.3 ATP ^{A)}: a) Remote beacon, # is distance to signal b) Beacon at signal c) Loop, short, # is length d) Loop, long, # is length |  |
| 12.4 TPWS: a) Overspeed sensor, arming and trigger loops b) Trainstop, arming and trigger loops at signal |  |
| 12.5 ETCS type balise on uni-directional line, + is identification number and # is application code a) Travelling to right b) Travelling to left |  |




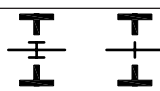
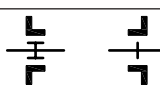

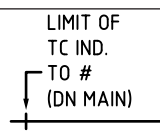



Table 12 Train warning and protection

| | | | |
|---|---|--|---|
| 12.6 Selective door opening beacon |  | | |
| 12.7 Detonator placer, emergency: a) Normally on b) Normally off |  a) | |  b) |
| 12.8 Train stop apparatus: a) Train stop b) Trip cock tester c) Trip cock test indicator |  a) |  b) |  c) |
| A) The arrows indicate the direction of travel. | | | |

Miscellaneous features shall be indicated on schematics with the symbols given in Table 13.

NOTE For cable route symbols see BS 376-2.

Table 13 Miscellaneous

| Symbol type | Symbol | | |
|--|---|---|--|
| 13.1 Siren |  | | |
| 13.2 Bell: a) Single stroke b) Trembler |  a) |  b) | |
| 13.3 Train activated warning system, limits of protection |  | | |
| 13.4 Lockout system, limits of protection A) |  | | |
| 13.5 Hot axle box detector |  | | |
| 13.6 Area covered by a signal box, limit, # is signal box name |  | | |
| 13.7 Boundary of areas covered by interlocking, across width of plan if possible |  | | |
| 13.8 Access point to railway: a) Foot b) Vehicle |  a) |  b) | |

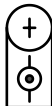

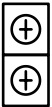
A) Type of protection to be defined on plan.

Block and release apparatus shall be indicated on schematics with the symbols given in Table 14.

Table 14 Block and release apparatus

| Apparatus type | Symbol | |
|---|---------|--|
| 14.1 Emergency replacement switch (ERS), # is number of protection switches | | |
| 14.2 Trackside engineering zone protection (EZP) switch | | |
| 14.3 Local release of signalling controls, # is unique identification number | LR# | |
| 14.4 Point key switch crank-handle release key on electric operated point machine, # is point number(s) | | |
| 14.5 Switch lock: a) Without indicator b) With indicator | | |
| 14.6 Occupation key instrument | | |
| 14.7 Block instrument (permissive): a) Non-peg b) Peg | | |
| 14.8 Block instrument (absolute non-controlled): a) Non-peg b) Peg | | |
| 14.9 Block instrument (absolute controlled): a) Non-peg b) Peg | | |
| 14.10 Combined block instrument | | |
| 14.11 Block switch, with control | | |
| 14.12 Token instrument, # is K - key token, S - staff, T - tablet, MS - miniature staff, NST - no signaller token. Token configuration to be shown above instrument, e.g. "A". | | |

Table 14 Block and release apparatus

| | | |
|--|---|---|
| <p>14.13 Key release instrument</p> |  | |
| <p>14.14 Level crossing block indicator: a) Single b) Double</p> |  <p>a)</p> |  <p>b)</p> |

7 Level crossings

Level crossings shall be indicated on schematics with the symbols given in Table 15.

Table 15 Level crossing

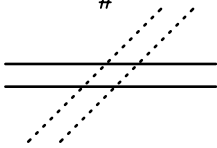
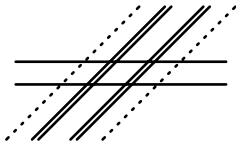
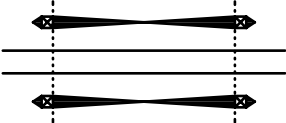
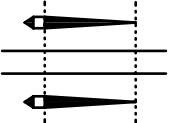
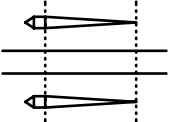
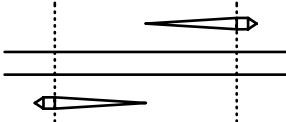
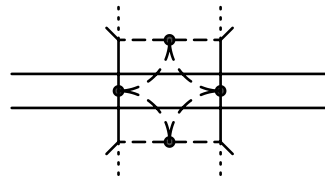
| Symbol type | Symbol | |
|--|---|---|
| <p>15.1 Road crossing ^{A)}</p> | <p>#</p>  | |
| <p>5.2 Road crossing with tramway tracks</p> |  | |
| <p>15.3 Interlocked lifting barriers: a) Worked from signal box or gate box, e.g. 4-barrier MCB b) Worked from ground, e.g. 2 full barriers</p> |  <p>a)</p> |  <p>b)</p> |
| <p>15.4 Non-interlocked lifting barriers: a) Worked from ground, e.g. full barrier TOB, UWC b) Automatically worked, e.g. half barrier AHB, ABCL</p> |  <p>a)</p> |  <p>b)</p> |

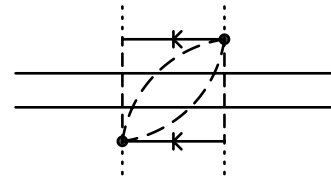
Table 15 Level crossing

15.5 Interlocked gates:

a) Worked from signal box or gate box, e.g. 4-gate MCG, sympathetic, normally across railway



a)

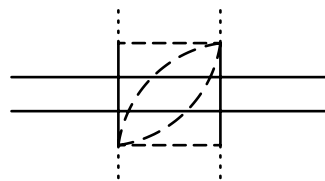


b)

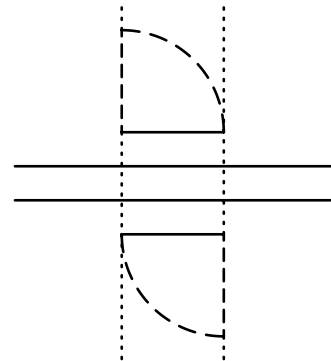
b) Worked from ground, e.g. 2 gates, non-sympathetic, normally across road ^{B)}

15.6 Non-interlocked gates:

a) Worked from ground, e.g. non-sympathetic gates, normally across railway, TOG



a)



b)

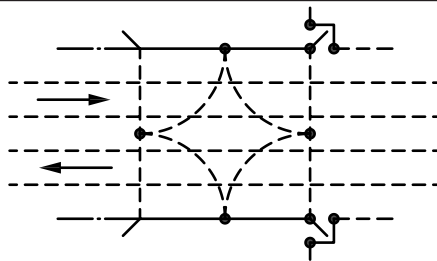
b) User worked, opening away from railway

15.7 Level crossing pedestrian gates:

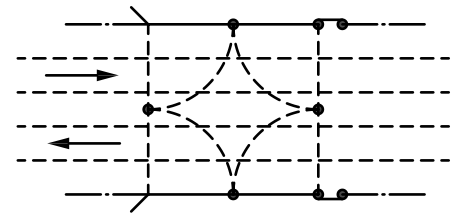
a) With ordinary angle-pen wickets

b) With spring wickets

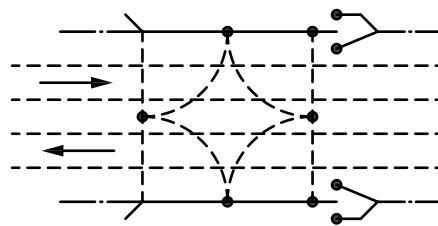
c) With cage gates



a)



b)



c)

15.8 Wicket gate where locked, C is controlled:

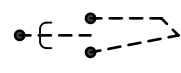
a) Ordinary angle-pen wickets



a)



b)



c)

b) Spring wickets

c) Cage gates

15.9 Level crossing audible warning, # is type



Table 15 Level crossing


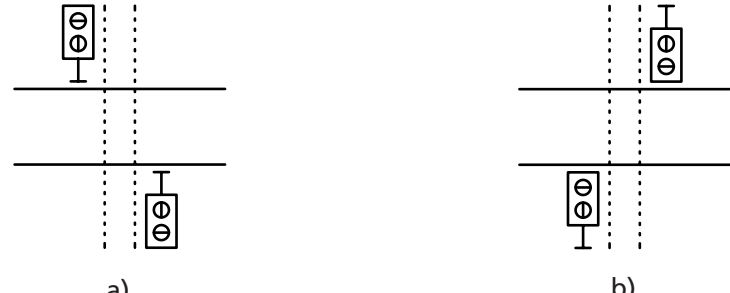
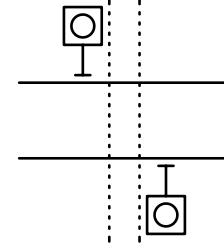
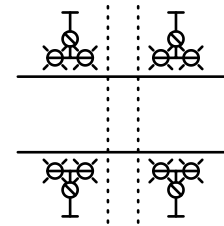
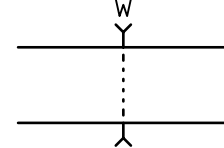
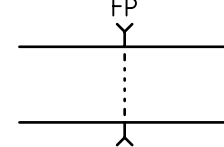

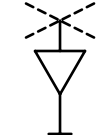


| | |
|--|--|
| <p>15.10 Local control: a) Local control unit (LCU) b) Local crossing clear unit (XCU)</p> |  |
| <p>15.11 Miniature stop (warning) lights: a) Orientated toward railway, e.g. pedestrian b) Orientated away from railway, e.g. vehicular</p> |  |
| <p>15.12 Barrow crossing lights</p> |  |
| <p>15.13 Road traffic lights</p> |  |
| <p>15.14 Authorized walkway across railway (staff crossing)</p> |  |
| <p>15.15 Footpath across railway</p> |  |
| <p>15.16 St Andrews cross sign: a) OC b) AOCL</p> |  |
| <p>15.17 Give way sign, open crossing</p> |  |

Table 15 Level crossing

| | |
|---|---|
| 15.18 Level crossing illumination, floodlight |  |
| 15.19 Closed circuit television camera |  |

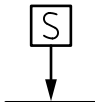
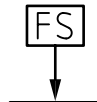

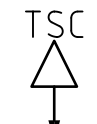

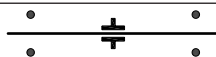
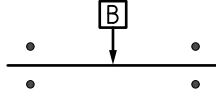
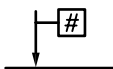
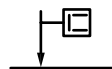
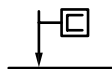
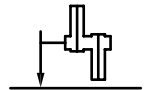
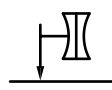
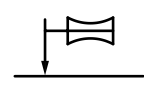
^{A)} # is crossing name and type as follows:

- MCG: manually controlled gated crossing;
- MCB: manually controlled barrier crossing;
- MCB-CCTV: manually controlled barrier crossing with closed circuit television;
- MCB-OD: controlled barrier crossing with obstacle detection;
- AHB: automatic half barrier crossing;
- ABCL: automatic barrier crossing locally monitored;
- AOCL: automatic open crossing locally monitored;
- TOG: train crew operated gated crossing;
- TOB: train crew operated barrier crossing;
- OC: open crossing;
- UWC: user worked crossing;
- FP: footpath crossing;
- BW: bridleway crossing.

^{B)} Where provided: B is Blacks locks, C is C locks and K is key locks.

Electric traction features shall be indicated on schematics with the symbols given in Table 16.

Table 16 Traction

| Symbol type | Symbol |
|--|---|
| 16.1 Electric traction ^{A)} : a) S is sub station (d.c.) b) FS is feeder station (a.c.) c) T is track paralleling hut (d.c.) d) TSC is track sectioning cabin (a.c.) |  a)  b)  c)  d) |
| 16.2 Automatic power control magnets |  |
| 16.3 Neutral section ^{B)} |  |
| 16.4 Booster transformer ^{B), C)} |  |
| 16.5 Circuit breaker sign: a) Warning, # is distance to sign b) Open c) Close |  a)  b)  c) |
| 16.6 Change of current collection zone: a) Warning b) Commencement c) Termination |  a)  b)  c) |

^{A)} The arrow indicates the point of return feeder.

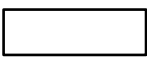
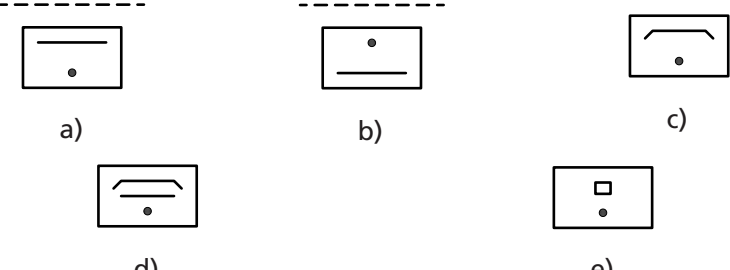

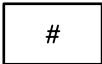

^{B)} The dots indicate limits of restricted area for signal positioning.

^{C)} The arrow indicates the connection point to the overhead line.

8 Buildings

Buildings shall be indicated on schematics with the symbols given in Table 17.

Table 17 Building symbols

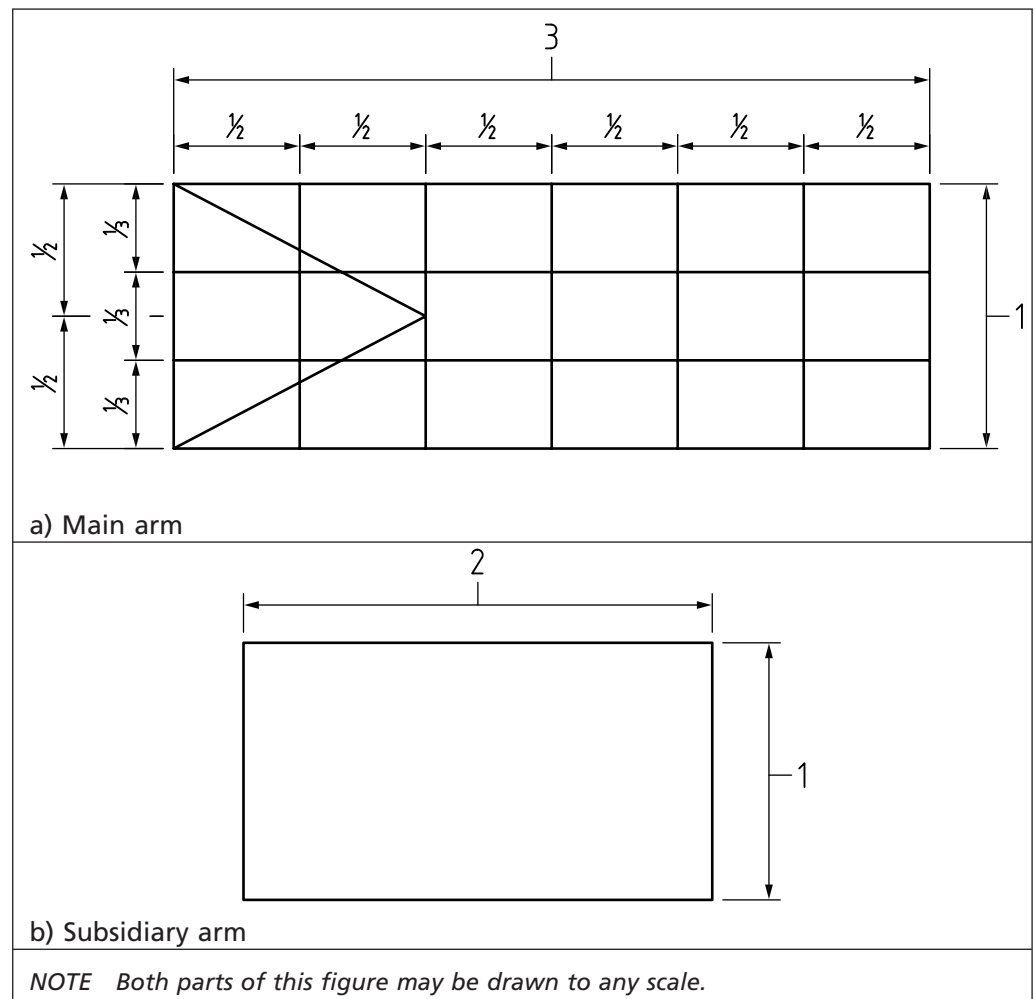
| Building type | Symbol |
|--|--|
| 17.1 Station platform |  |
| 17.2 Signal box: a) Operator facing track b) Operator with back to track c) With panel only d) Console and diagram e) With VDU workstation |  |
| 17.3 Crossing keeper's hut or gate box [unless one of 17.2a) to e) is applicable] |  |
| 17.4 Equipment room, # is RR for relay room, SER for signalling equipment room, I for interlocking, REB for relocatable equipment building |  |
| 17.5 Ground frame: a) Uncovered ^{A)} b) Covered ^{A)} c) Switch panel, # is number of control functions d) Switch panel, covered, # is number of control functions |  |

^{A)} The number of strokes indicates the number of levers in the frame.

Annex A Proportions for semaphore arms (normative)

Proportions for semaphore arms shall be drawn in accordance with Figure A.1, which gives the comparative sizes of main and subsidiary signal arms.

Figure A.1 Semaphore arms



Bibliography

The following documents are informatively referenced within this document. For dated references, only the edition cited applies. For undated references, the latest edition of the referenced document (including any amendments) applies.

BS 376-2, *Railway signalling symbols – Wiring symbols and written circuits*

British Standards Institution (BSI)

BSI is the national body responsible for preparing British Standards and other standards-related publications, information and services.

BSI is incorporated by Royal Charter. British Standards and other standardization products are published by BSI Standards Limited.

About us

We bring together business, industry, government, consumers, innovators and others to shape their combined experience and expertise into standards-based solutions.

The knowledge embodied in our standards has been carefully assembled in a dependable format and refined through our open consultation process. Organizations of all sizes and across all sectors choose standards to help them achieve their goals.

Information on standards

We can provide you with the knowledge that your organization needs to succeed. Find out more about British Standards by visiting our website at bsigroup.com/standards or contacting our Customer Services team or Knowledge Centre.

Buying standards

You can buy and download PDF versions of BSI publications, including British and adopted European and international standards, through our website at bsigroup.com/shop, where hard copies can also be purchased.

If you need international and foreign standards from other Standards Development Organizations, hard copies can be ordered from our Customer Services team.

Subscriptions

Our range of subscription services are designed to make using standards easier for you. For further information on our subscription products go to bsigroup.com/subscriptions.

With **British Standards Online (BSOL)** you'll have instant access to over 55,000 British and adopted European and international standards from your desktop. It's available 24/7 and is refreshed daily so you'll always be up to date.

You can keep in touch with standards developments and receive substantial discounts on the purchase price of standards, both in single copy and subscription format, by becoming a **BSI Subscribing Member**.

PLUS is an updating service exclusive to BSI Subscribing Members. You will automatically receive the latest hard copy of your standards when they're revised or replaced.

To find out more about becoming a BSI Subscribing Member and the benefits of membership, please visit bsigroup.com/shop.

With a **Multi-User Network Licence (MUNL)** you are able to host standards publications on your intranet. Licences can cover as few or as many users as you wish. With updates supplied as soon as they're available, you can be sure your documentation is current. For further information, email bsmusales@bsigroup.com.

BSI Group Headquarters

389 Chiswick High Road London W4 4AL UK

Revisions

Our British Standards and other publications are updated by amendment or revision.

We continually improve the quality of our products and services to benefit your business. If you find an inaccuracy or ambiguity within a British Standard or other BSI publication please inform the Knowledge Centre.

Copyright

All the data, software and documentation set out in all British Standards and other BSI publications are the property of and copyrighted by BSI, or some person or entity that owns copyright in the information used (such as the international standardization bodies) and has formally licensed such information to BSI for commercial publication and use. Except as permitted under the Copyright, Designs and Patents Act 1988 no extract may be reproduced, stored in a retrieval system or transmitted in any form or by any means – electronic, photocopying, recording or otherwise – without prior written permission from BSI. Details and advice can be obtained from the Copyright & Licensing Department.

Useful Contacts:

Customer Services

Tel: +44 845 086 9001

Email (orders): orders@bsigroup.com

Email (enquiries): cservices@bsigroup.com

Subscriptions

Tel: +44 845 086 9001

Email: subscriptions@bsigroup.com

Knowledge Centre

Tel: +44 20 8996 7004

Email: knowledgecentre@bsigroup.com

Copyright & Licensing

Tel: +44 20 8996 7070

Email: copyright@bsigroup.com



...making excellence a habit.™