

BRITISH STANDARD

CONFIRMED
JANUARY 1982

**BS 131-1:
1961**

*Incorporating
Amendment Nos. 1
and 2*

Methods for

Notched bar tests —

Part 1: The izod impact test on metals

UDC 620.178.746

NO COPYING WITHOUT BSI PERMISSION EXCEPT AS PERMITTED BY COPYRIGHT LAW



Co-operating organizations

The Mechanical Engineering Industry Standards Committee, under whose supervision this British Standard was prepared, consists of representatives from the following Government departments and scientific and industrial organizations:

Admiralty*	Gas Council
Air Ministry	High Commission of India
Associated Offices' Technical Committee	Institute of Marine Engineers
Association of Consulting Engineers (Incorporated)	Institute of Petroleum
British Chemical Plant Manufacturers Association	Institution of Civil Engineers
British Compressed Air Society	Institution of Gas Engineers
British Electrical and Allied Manufacturers' Association*	Institution of Heating and Ventilating Engineers
British Engineers' Association	Institution of Mechanical Engineers*
British Gear Manufacturers' Association	Institution of Mechanical Engineers (Automobile Division)
British Internal Combustion Engine Manufacturers' Association	Institution of Production Engineers*
British Iron and Steel Federation*	Locomotive and Allied Manufacturers' Association of Great Britain
British Railways, the British Transport Commission	Machine Tool Trades Association
Crown Agents for Oversea Governments and Administrations	Ministry of Labour (Factory Inspectorate)
D.S.I.R.—National Engineering Laboratory*	Ministry of Power
Electricity Council, The Generating Board and the Area Boards in England and Wales	Ministry of Transport
Engineering Equipment Users' Association	Ministry of Works
	National Coal Board
	National Physical Laboratory (D.S.I.R.)*
	Radio Industry Council
	War Office*

The Government departments and scientific and industrial organizations marked with an asterisk in the above list, together with the following, were directly represented on the Committee entrusted with the preparation of this standard:

Alloy Steels Association	Council of British Manufacturers of Petroleum Equipment
Aluminium Development Association	D.S.I.R.—Building Research Station
Aluminium Industry Council	D.S.I.R.—Forest Products Laboratory
Association of British Chemical Manufacturers	Institute of Welding
British Cast Iron Research Association	Institution of Engineering Inspection
British Constructional Steelwork Association	Lloyd's Register of Shipping
British Iron and Steel Research Association	Ministry of Aviation
British Non-ferrous Metals Research Association	Testing Houses
British Welding Research Association	Testing Machine Manufacturers and Individual Firms

This British Standard, having been approved by the Mechanical Engineering Industry Standards Committee and endorsed by the Chairman of the Engineering Divisional Council, was published under the authority of the General Council on 30th May, 1961

© BSI 03-1999

First published August, 1920
First revision, August, 1933
Second revision, May, 1961

The following BSI references relate to the work on this standard:
Committee reference ISM/NFM/4
Draft for comment A(MEE) 9391

ISBN 0 580 00761 8

Amendments issued since publication

Amd. No.	Date	Comments
(PD 4651)	September 1962	
5069	March 1986	Indicated by a sideline in the margin

Contents

	Page
Co-operating organizations	Inside front cover
Foreword	ii
<hr/>	
1 Scope	1
2 Form and dimensions of test piece	1
3 Preparation of test piece	1
4 Testing machine	1
5 Striking energy	1
6 Test requirements	10
7 Testing Temperature	10
8 Presentation of results	10
<hr/>	
Appendix A Installation of the testing machine	12
Appendix B Curved notch circular section test piece	12
Appendix C Rectangular section subsidiary test pieces	16
<hr/>	
Figure 1 — Single notch square section test piece	3
Figure 2 — Two notch square section test piece	3
Figure 3 — Three notch square section test piece	4
Figure 4 — Enlarged section of notch for square section test pieces	5
Figure 5 — Single notch circular section test piece	7
Figure 6 — Two notch circular section test piece	7
Figure 7 — Three notch circular section test piece	8
Figure 8 — Enlarged section of notch for circular section test pieces	9
Figure 9 — Sketch showing angle and radius of striker, and inclination of striker to horizontal for cantilever type test piece (elevation)	11
Figure 10 — Sketch showing local increase in width of locating groove for square section test pieces	11
Figure 11 — Single curved notch circular section test piece	13
Figure 12 — Two curved notch circular section test piece	13
Figure 13 — Three curved notch circular section test piece	14
Figure 14 — Enlarged section of curved notch for circular section test piece	15
<hr/>	
Table 1 — Dimensions and tolerances of ferrous and non-ferrous square section test pieces	2
Table 2 — Dimensions and tolerances of ferrous and non-ferrous circular section test pieces	6
Table 3 — Dimensions and tolerances of ferrous and non-ferrous curved notch circular section test pieces	12
Table 4 — Dimensions and tolerances of ferrous and non-ferrous rectangular section subsidiary test pieces	16
<hr/>	

Foreword

In order to keep abreast of progress in the industries concerned, British Standards are subject to periodical review. Suggestions for improvements will be recorded and in due course brought to the notice of the committees charged with the revision of the standards to which they refer.

A complete list of British Standards, numbering over 9,000, fully indexed and with a note of the contents of each, will be found in the BSI Catalogue which may be purchased from BSI Sales Department. The Catalogue may be consulted in many public libraries and similar institutions.

This standard makes reference to the following British Standard:

BS 131-2, *Charpy V-notch impact test on metals*.

This British Standard which states the requirements for the Izod Impact Test on metals is published as Part 1 of a revision of BS 131. Part 2 previously published gives the requirements for the Charpy V-notch test.

The work of Technical Committee 17, "Steel", of the International Organization for Standardization (ISO) has been taken into account in preparing the standard and the square section and circular section straight notch test pieces are in accordance with ISO Recommendation R84. The scope has also been widened to include details of the method of test together with structural and dimensional requirements for testing machines.

Dimensions with appropriate machining tolerances are given for standard 10 mm square section and standard circular section test pieces. The use of the curved notch circular section test piece is not preferred, but at the request of the steel industry the form and dimensions of this test piece are given in an Appendix.

After due consideration of the requirements of certain sections of industry for subsidiary test pieces of cross-section smaller than 10 mm × 10 mm, it has been decided to omit the two given in the 1933 revision of the standard, and to introduce in an appendix two new subsidiary test pieces having dimensions of 10 mm × 7.5 mm and 10 mm × 5 mm with the notch cut in a narrow face. These are intended for use only when it is impossible to obtain a standard test piece from the material available. It should be noted that no trustworthy relationship has been found between the energies absorbed in breaking test pieces of different sizes and only results of test pieces of identical dimensions should be compared.

In this standard no reference is made to the number of tests required for particular applications as this is regarded as part of the specification for the material.

It should also be noted that no reliable relationship has been found between different types of impact test, and conversions from Izod impact test results to Charpy-V-notch or Charpy U-notch values are not recommended.

A British Standard does not purport to include all the necessary provisions of a contract. Users of British Standards are responsible for their correct application.

Compliance with a British Standard does not of itself confer immunity from legal obligations.

Summary of pages

This document comprises a front cover, an inside front cover, pages i and ii, pages 1 to 16 and a back cover.

This standard has been updated (see copyright date) and may have had amendments incorporated. This will be indicated in the amendment table on the inside front cover.

1 Scope

This British Standard specifies the conditions for carrying out the Izod impact test on metals. The test consists of measuring the energy absorbed in breaking a notched test piece by one blow from a striker carried by a pendulum. The test piece is gripped vertically with the root of the notch in the same plane as the upper face of the grips. The blow is struck on the same face as the notch and at a fixed height above it.

2 Form and dimensions of test piece

The standard test pieces shall have dimensions and tolerances in accordance with Table 1 or Table 2 and shall conform to the appropriate figures as follows:

a) *Test pieces with square section*
(10 mm × 10 mm).

Figure 1 With single notch.

Figure 2 With two notches.

Figure 3 With three notches.

b) *Test pieces with circular section* (0.45 inch diameter).

Figure 5 With single straight notch.

Figure 6 With two straight notches.

Figure 7 With three straight notches.

Where more than one notch is cut in a test piece the notches shall be spaced as shown in Table 1 or Table 2. The notches shall be cut around the test pieces as shown in Figure 2, Figure 3, Figure 6 and Figure 7 unless otherwise required by the material specification.

The plane of symmetry of the notch shall be perpendicular to the longitudinal axis of the test piece, i.e. the direction of the notch shall be at right angles to the longitudinal axis of the test piece and the plane of symmetry of the notch shall be at right angles to the face in which it is cut.

Dimensions and tolerances for curved notch circular section test pieces are given in Appendix B, and those for rectangular section subsidiary test pieces in Appendix C.

3 Preparation of test piece

The schedule of operations for producing a test piece will in general be a matter for the specification of the material being tested.

Details of the notches are given in Figure 4 and Figure 8.

Unless a particular method of preparing the notch is specified in the standard for the material, it may be cut by any machining method provided that a smooth contour of the specified form is produced. Attention is drawn to the fact that the impact properties of some materials are affected by the method employed.

4 Testing machine

The testing machine shall be constructed and installed steady and rigid (see Appendix A).

The following conditions shall be satisfied (see Figure 9)

Distance between plane of symmetry of notch and line of contact between test piece and striker	22 ± 0.5 mm
Angle at tip of striker	75 ± 1°
Radius at tip of striker	0.5 – 1.0 mm
Angle between face of test piece and under-side face of striker	100 ± 1°
Speed of striker at instant of impact	3 – 4 m/s (9.8 – 13.1 ft/s)

The plane of swing of the striker shall be vertical. The machine shall be so constructed that the loss of energy (such as from translation, rotation or vibration) in the machine framework during a test is negligible. The radius of the centre of percussion about the axis of rotation shall be equal to the radius of the striker about this axis within a tolerance of ± 1 per cent.

5 Striking energy

In general a machine of 120 ft lb (16.6 kg m) capacity will be found adequate for most materials. Smaller machines of 20 ft lb or 60 ft lb (2.76 or 8.3 kg m) will provide better discrimination with materials of very low energy absorption.

When recording the energy absorbed the capacity of the machine shall also be indicated (see Clause 8).

Table 1 — Dimensions and tolerances of ferrous and non-ferrous square section test pieces

Item	Nominal dimensions		Machining tolerances			
			Ferrous test pieces		Non-ferrous test pieces	
	Millimetre	Inch equivalents	Millimetre	Inch equivalents	Millimetre	Inch equivalents
Minimum overall length of test piece:	70	2.76	—	—	—	—
1 Notch	98	3.86	—	—	—	—
2 Notch	126	4.96	—	—	—	—
3 Notch						
Width	10	0.394	± 0.10	± 0.004	± 0.05	± 0.002
Thickness	10	0.394	± 0.10	± 0.004	± 0.05	± 0.002
Root radius of notch	0.25	0.010	± 0.025	± 0.001	± 0.025	± 0.001
Depth below notch measured at both ends	8	0.315	± 0.10	± 0.004	± 0.025	± 0.001
Distance of plane of symmetry of notch from free end of test piece and from adjacent notch	28	1.1	± 0.41	± 0.016	± 0.41	± 0.016
Angle of notch	45°		± 2°		± 1°	

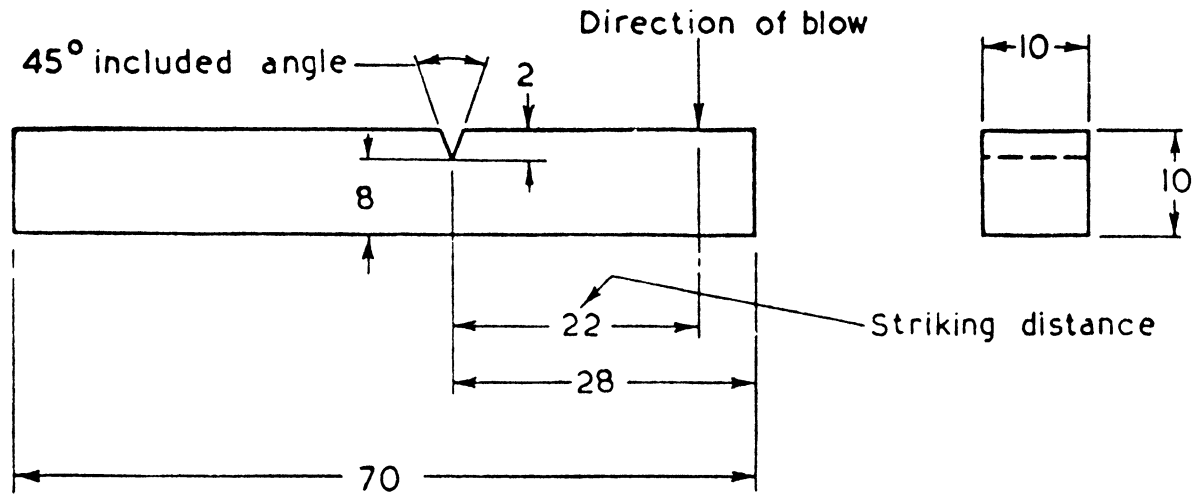

Figure 1 — Single notch square section test piece

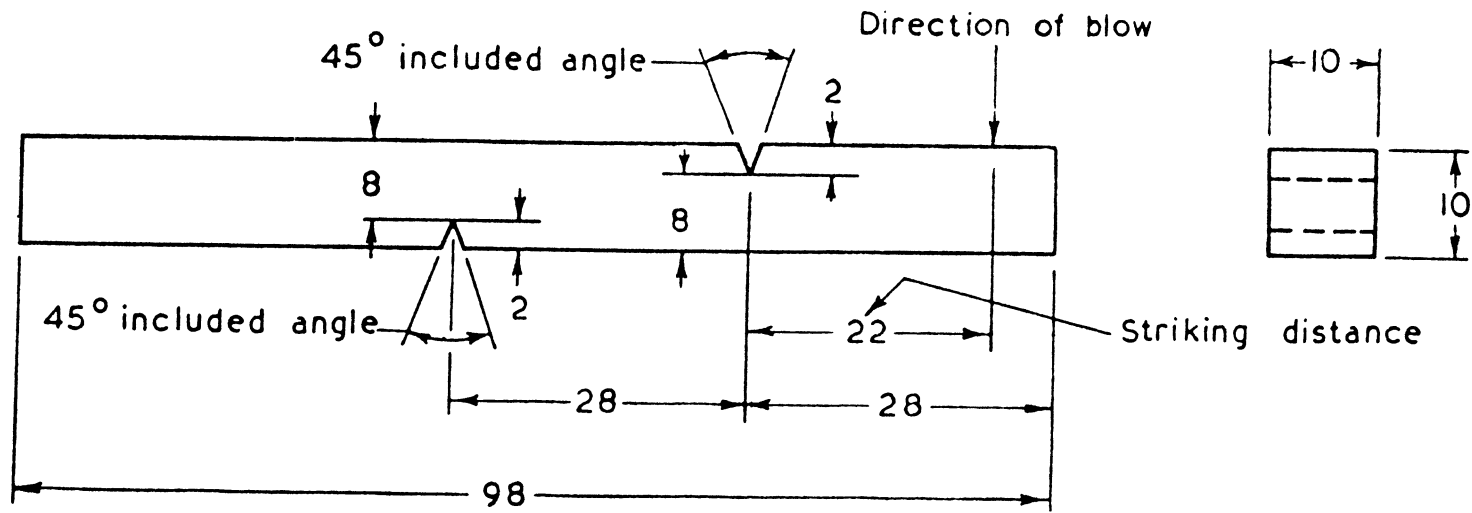
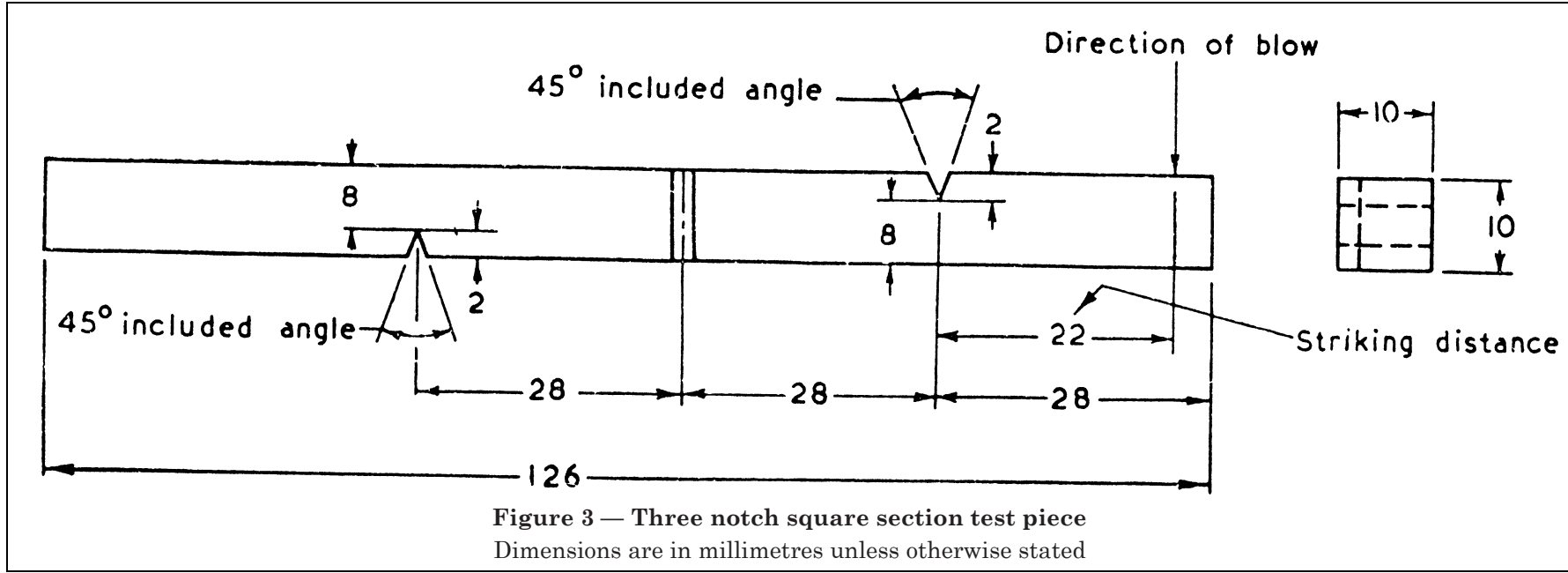

Figure 2 — Two notch square section test piece
Dimensions are in millimetres unless otherwise stated.



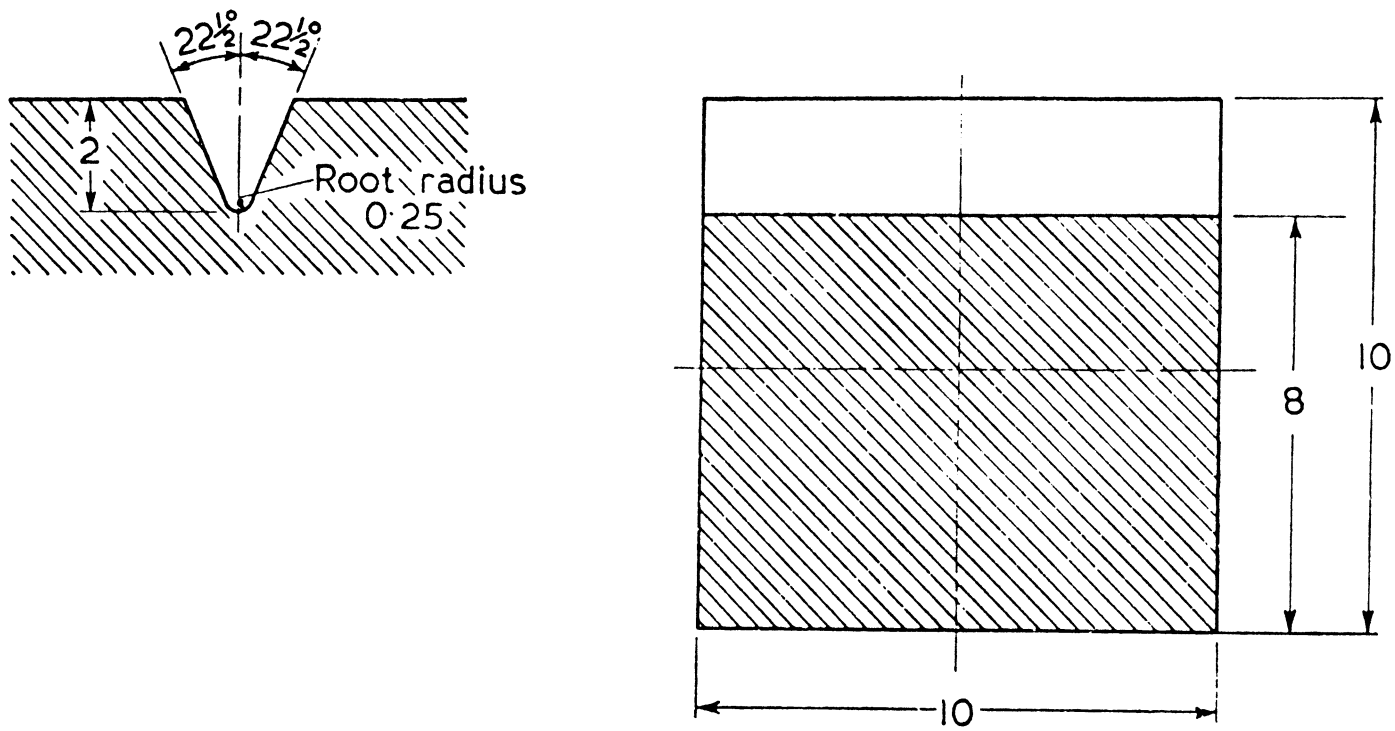

Figure 4 — Enlarged section of notch for square section test pieces
Dimensions are in millimetres unless otherwise stated

Table 2 — Dimensions and tolerances of ferrous and non-ferrous circular section test pieces

Item	Nominal dimensions		Machining tolerances			
			Ferrous test pieces		Non-ferrous test pieces	
	Inch	Millimetre equivalents	Inch	Millimetre equivalents	Inch	Millimetre equivalents
Minimum overall length of test piece:						
1 Notch	2.8	71	—	—	—	—
2 Notch	3.9	99	—	—	—	—
3 Notch	5.0	127	—	—	—	—
Diameter	0.45	11.43	± 0.001	± 0.025	± 0.001	± 0.025
Root radius of notch	0.010	0.25	± 0.001	± 0.025	± 0.001	± 0.025
Depth below notch	0.32	8.13	± 0.004	± 0.10	± 0.002	± 0.05
Distance of plane of symmetry of notch from free end of test piece and from adjacent notch	1.1	28	± 0.02	± 0.5	± 0.02	± 0.5
Angle of notch	45°		± 2°		± 1°	

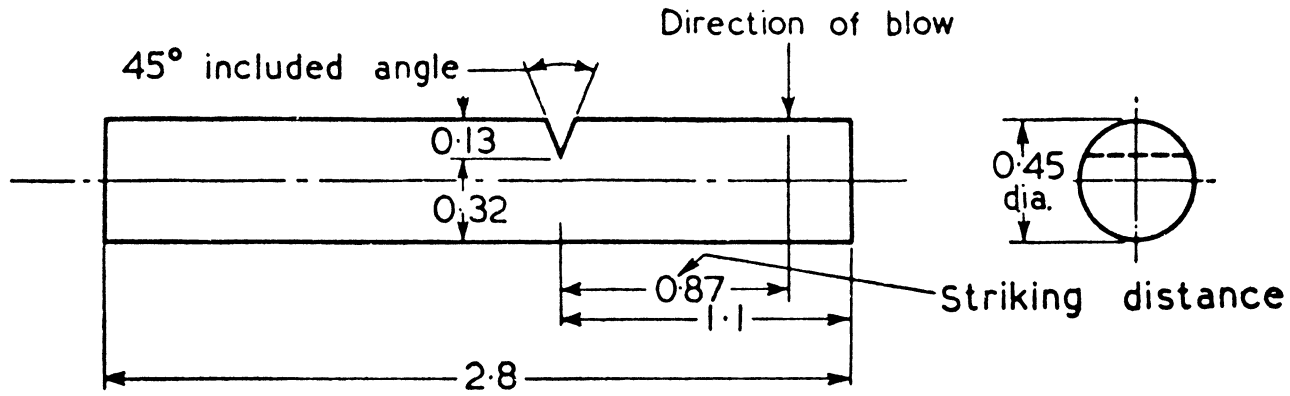

Figure 5 — Single notch circular section test piece

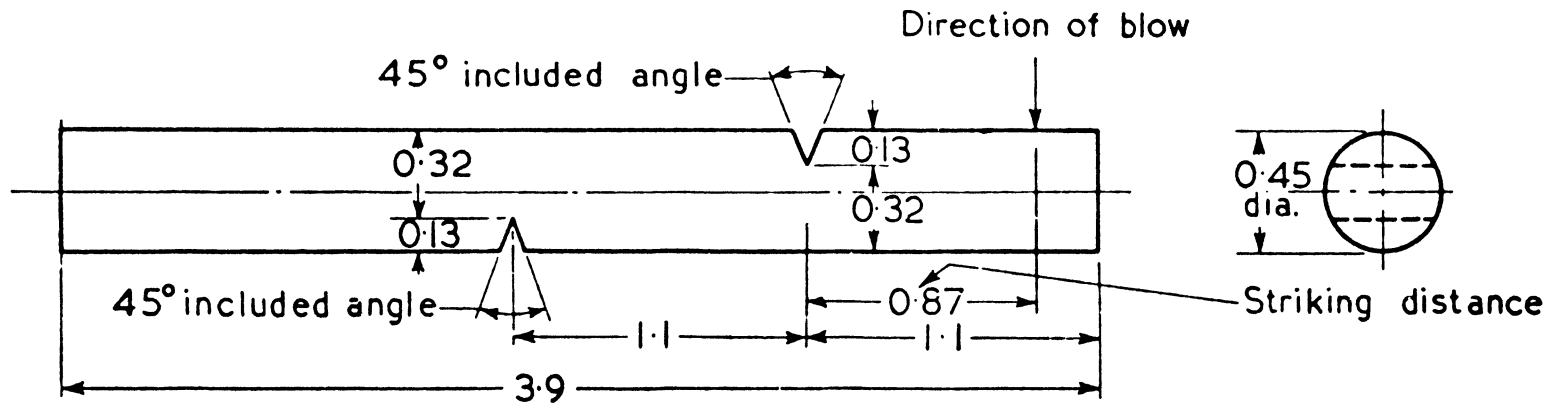
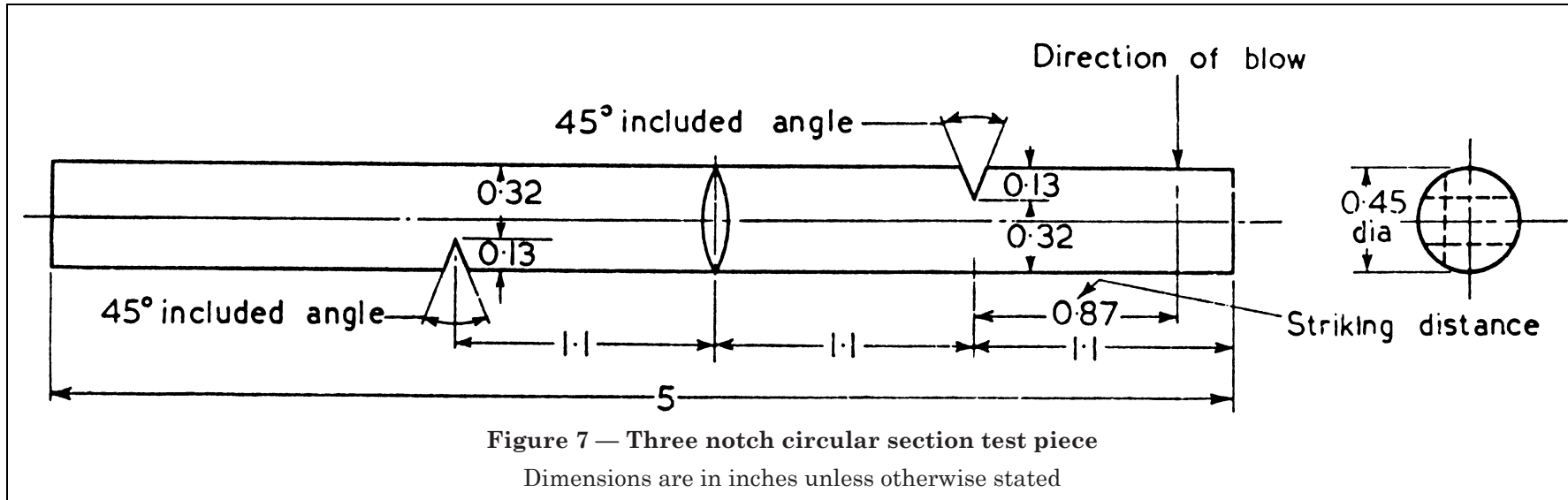

Figure 6 — Two notch circular section test piece

Dimensions are in inches unless otherwise stated.



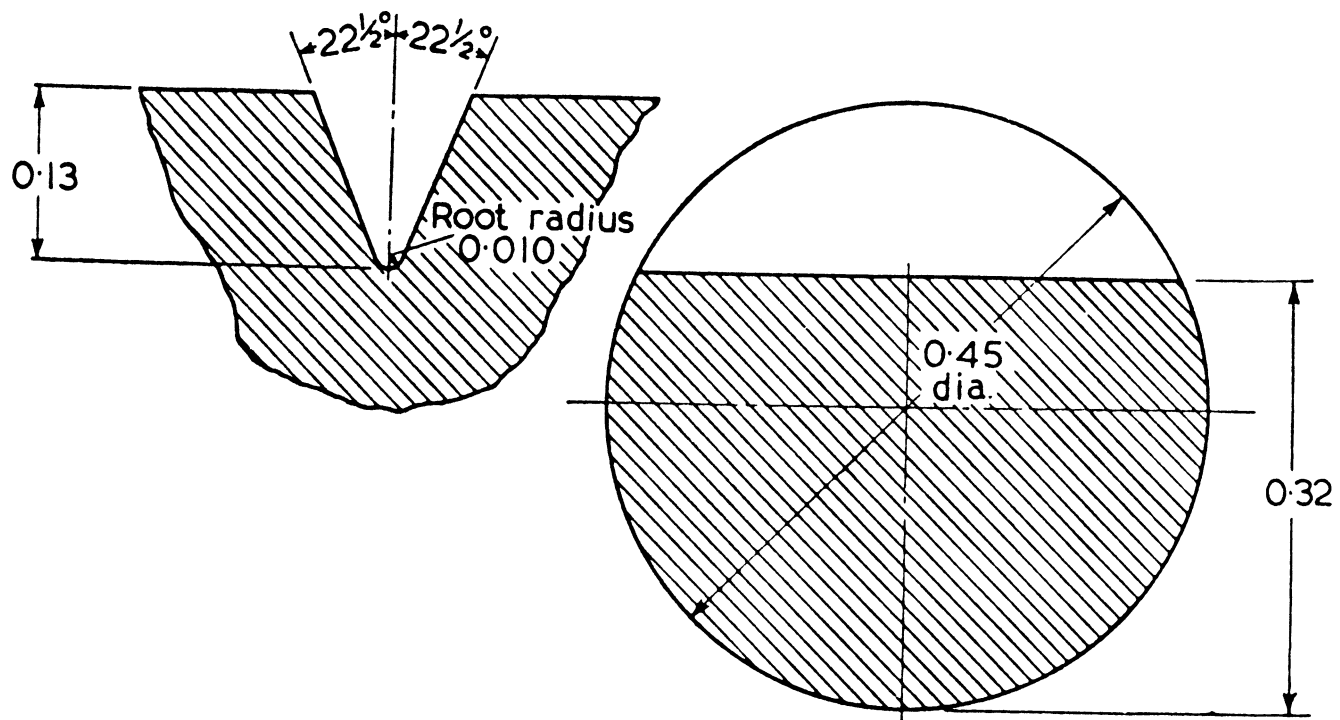

Figure 8 — Enlarged section of notch for circular section test pieces
Dimensions are in inches unless otherwise stated

6 Test requirements

The test piece shall be supported behind the notch by a rigid support block having a vertical groove to locate the test piece in the plane of swing of the pendulum. The groove shall accept test pieces having tolerances specified in Table 1, Table 2, Table 3 or Table 4. In the case of square specimens the groove shall be increased in width locally to 18.5 mm as shown in Figure 10 to allow flow of the material to occur in a direction normal to the plane of swing of the pendulum.

The top edge of the support about which bending takes place shall be slightly rounded. The test piece shall be rigidly clamped on the face containing the notch by a clamp block, and shall be so positioned that the plane of symmetry of the notch coincides with the top surface of the support and clamp blocks (see Figure 9).

When clamped, the face of a square and rectangular subsidiary test piece containing the notch shall lie in a plane which also includes the axis of rotation of the pendulum. The chord joining the extremities of the notch of a circular section test piece shall be parallel to the striking edge of the hammer. A positioning gauge is necessary to ensure that this condition is met.

When testing 2 notch and 3 notch test pieces the material remaining after each test shall be examined to ensure that any deformed metal does not interfere with the performance of the next test.

7 Testing temperature

The test shall be carried out with the test piece at the ambient temperature of the test house.

NOTE In view of the difficulties of carrying out the Izod test at other than ambient temperatures, it is recommended that the Charpy V-notch test be used for testing at sub-ambient and elevated temperatures.

8 Presentation of results

The following information shall be included in respect of each test made:

- a) Type of test: Izod Impact.
- b) Striking energy of machine in ft lb (see Clause 5).
- c) Test piece used: standard (square or circular section, straight or curved notch) or subsidiary. If subsidiary, the width shall be stated.
- d) The energy absorbed in foot pounds.

If a standard test piece is used it is permissible to use symbols in giving the result of the test. The result shall then be prefaced by symbols such as "I 120 S" or "I 60 Rc" as appropriate to indicate respectively the type of test, the striking energy range of the machine used, and the type of section (S—square, Rs—circular, straight notch, or Rc—circular, curved notch):

"I 120 S: x ft lb".

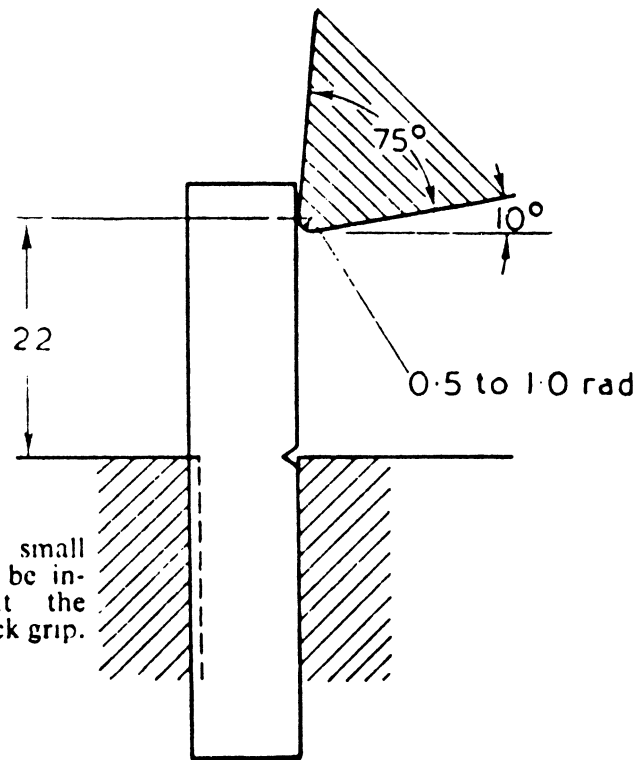

NOTE. A small radius should be incorporated at the edge of the back grip.

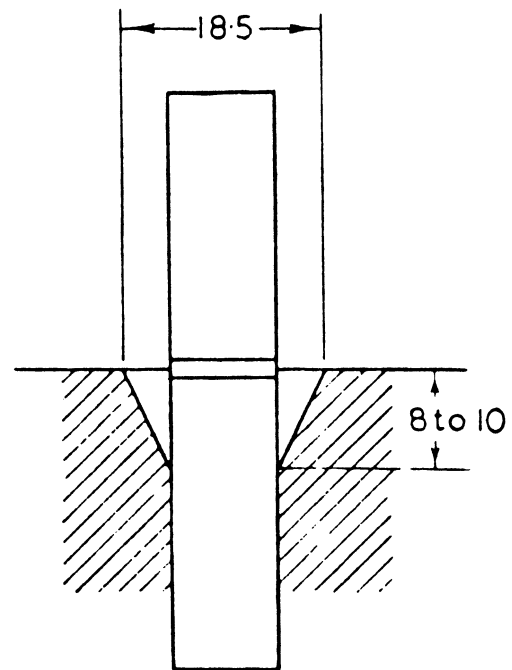

Figure 9 — Sketch showing angle and radius of striker, and inclination of striker to horizontal for cantilever type test piece (elevation)

Figure 10 — Sketch showing local increase in width of locating groove for square section test pieces

Dimensions are in millimetres unless otherwise stated

Appendix A Installation of the testing machine (See Clause 4)

It is recommended that the machine should be securely bolted to a concrete floor not less than 6 inches thick, or where this is not available should be bolted to a concrete or masonry foundation having a mass not less than 40 times that of the pendulum. Any lack of rigidity in the fixing of the machine or the anvil will affect the energy absorbed.

Appendix B Curved notch circular section test piece (See Foreword)

The curved notch circular section test piece shall have dimensions and tolerances in accordance with Table 3 and shall conform with the appropriate Figures as follows:

Figure 11 With single notch.

Figure 12 With two notches.

Figure 13 With three notches.

Details of the notch are given in Figure 14. Where more than one notch is cut in a specimen the notches shall be spaced as shown in Table 3. The notches shall be cut around the specimen as shown in Figure 12 and Figure 13 unless otherwise required by the material specification. The preparation of the test piece and notch shall conform with Clause 3.

Table 3 — Dimensions and tolerances of ferrous and non-ferrous curved notch circular section test pieces

Item	Nominal dimensions		Machining tolerances			
			Ferrous test pieces		Non-ferrous test pieces	
	Inch	Millimetre equivalents	Inch	Millimetre equivalents	Inch	Millimetre equivalents
Minimum overall length of test piece:						
1 Notch	2.8	71	—	—	—	—
2 Notch	3.9	99	—	—	—	—
3 Notch	5.0	127	—	—	—	—
Diameter	0.45	11.43	± 0.001	± 0.025	± 0.001	± 0.025
Root radius of notch	0.010	0.25	± 0.001	± 0.025	± 0.001	± 0.025
Depth below notch	0.33	8.38	± 0.004	± 0.10	± 0.002	± 0.05
Distance of plane of symmetry of notch from free end of test piece and from adjacent notch	1.1	28	± 0.02	± 0.5	± 0.02	± 0.5
Angle of notch	45°		± 2°		± 1°	

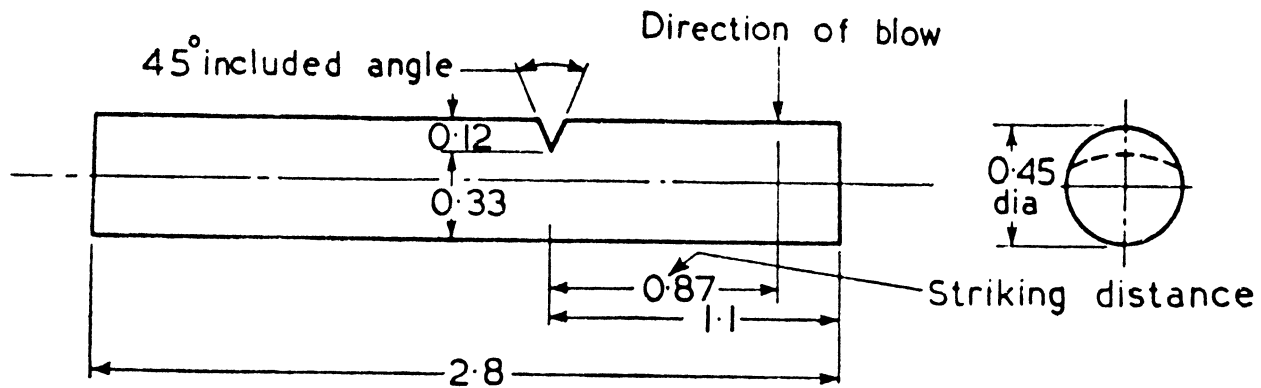

Figure 11 — Single curved notch circular section test piece

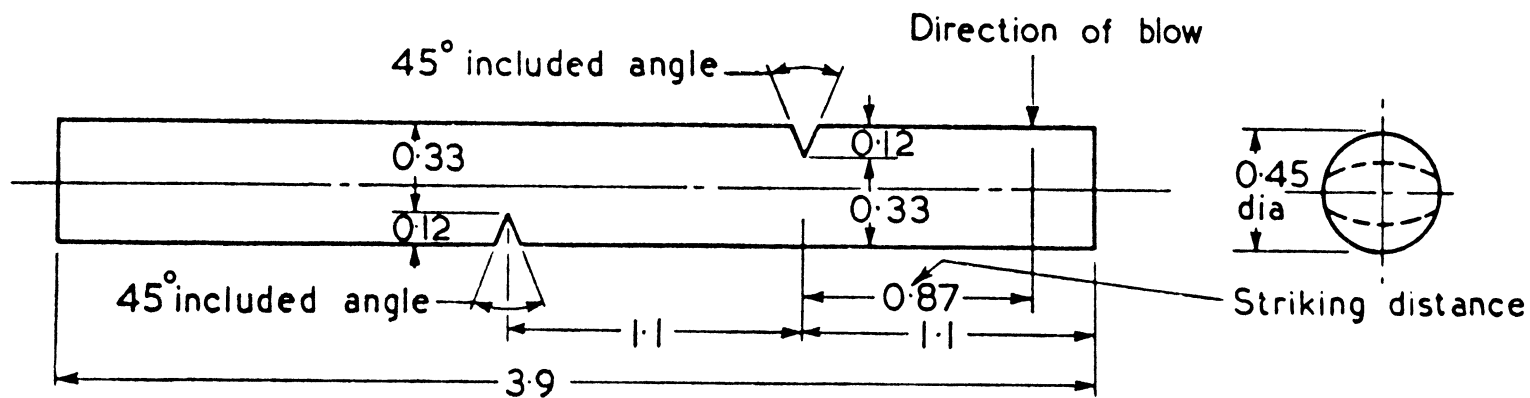
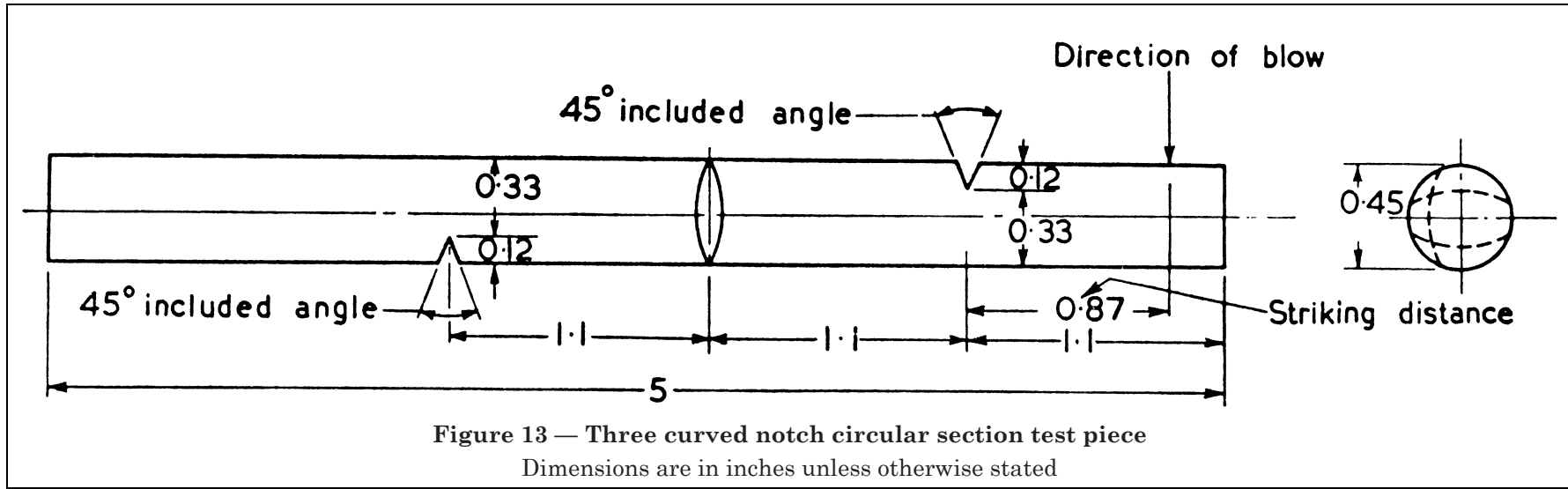

Figure 12 — Two curved notch circular section test piece
 Dimensions are in inches unless otherwise stated.



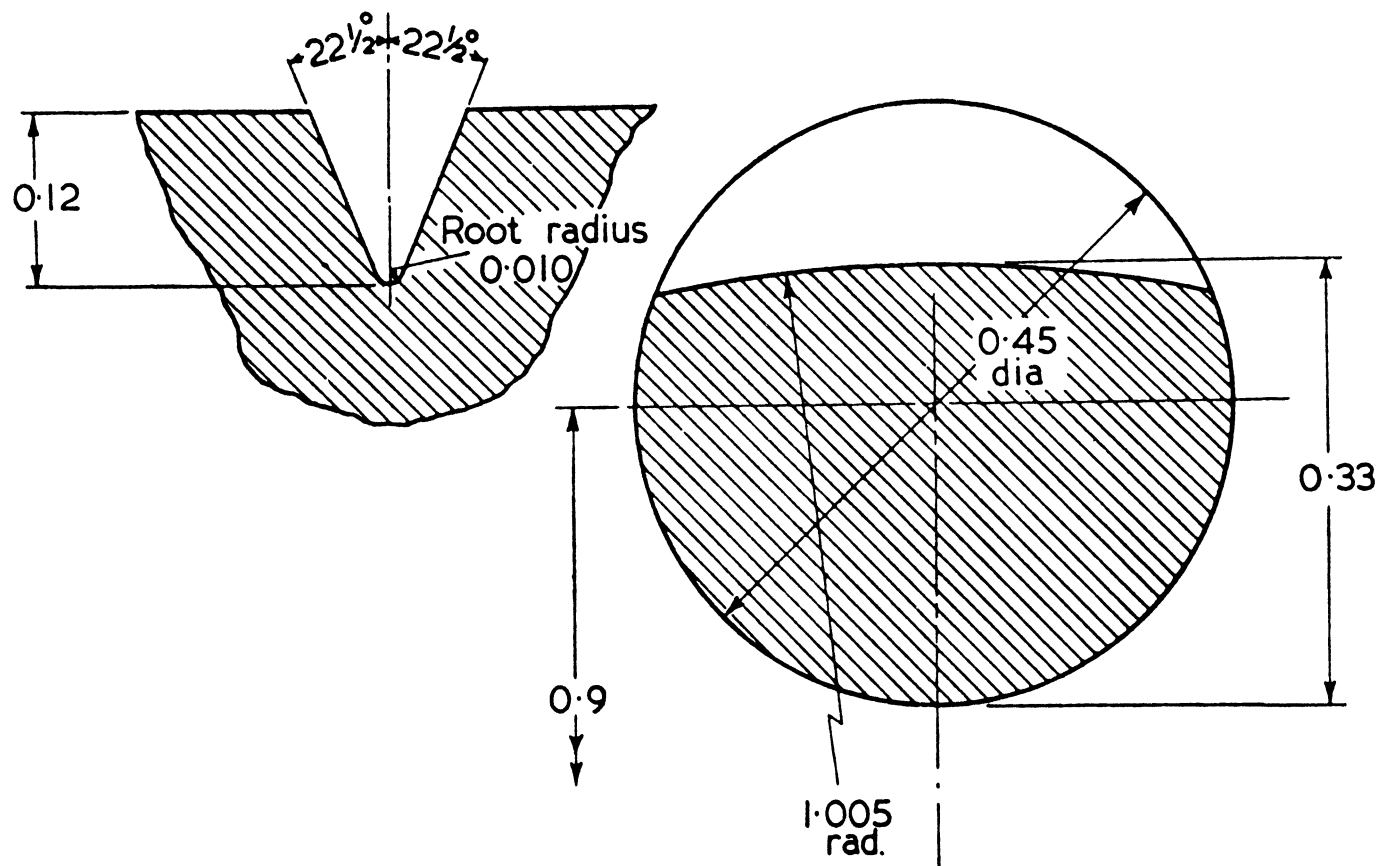

Figure 14 — Enlarged section of curved notch for circular section test piece
 Dimensions are in inches unless otherwise stated

Appendix C Rectangular section subsidiary test pieces (see Foreword)

Rectangular section subsidiary test pieces shall have dimensions and tolerances in accordance with Table 4. The notch shall be cut in a narrow face of the test piece and its details shall be as indicated in Figure 4. If two notches are cut in the test piece they shall be spaced as shown in Table 4, and the relative position of the notches shall be as indicated in Figure 2 unless otherwise stated in the standard for the material. The preparation of the test piece and notch shall conform with Clause 3.

Table 4 — Dimensions and tolerances of ferrous and non-ferrous rectangular section subsidiary test pieces

Item	Nominal dimensions		Machining tolerances			
			Ferrous test pieces		Non-ferrous test pieces	
	Millimetre	Inch equivalents	Millimetre	Inch equivalents	Millimetre	Inch equivalents
Minimum overall length of test piece:						
1 Notch	70	2.76	—	—	—	—
2 Notch	98	3.86	—	—	—	—
Width	7.5 5.0	0.295 0.197	± 0.10 ± 0.05	± 0.004 ± 0.002	± 0.05 ± 0.025	± 0.002 ± 0.001
Thickness	10	0.394	± 0.10	± 0.004	± 0.05	± 0.002
Root radius of notch	0.25	0.010	± 0.025	± 0.001	± 0.025	± 0.001
Depth below notch measured at both ends	8	0.315	± 0.10	± 0.004	± 0.025	± 0.001
Distance of plane of symmetry of notch from free end of test piece and from adjacent notch	28	1.1	± 0.41	± 0.016	± 0.41	± 0.016
Angle of notch	45°		± 2°		± 1°	

BSI — British Standards Institution

BSI is the independent national body responsible for preparing British Standards. It presents the UK view on standards in Europe and at the international level. It is incorporated by Royal Charter.

Revisions

British Standards are updated by amendment or revision. Users of British Standards should make sure that they possess the latest amendments or editions.

It is the constant aim of BSI to improve the quality of our products and services. We would be grateful if anyone finding an inaccuracy or ambiguity while using this British Standard would inform the Secretary of the technical committee responsible, the identity of which can be found on the inside front cover. Tel: 020 8996 9000. Fax: 020 8996 7400.

BSI offers members an individual updating service called PLUS which ensures that subscribers automatically receive the latest editions of standards.

Buying standards

Orders for all BSI, international and foreign standards publications should be addressed to Customer Services. Tel: 020 8996 9001. Fax: 020 8996 7001.

In response to orders for international standards, it is BSI policy to supply the BSI implementation of those that have been published as British Standards, unless otherwise requested.

Information on standards

BSI provides a wide range of information on national, European and international standards through its Library and its Technical Help to Exporters Service. Various BSI electronic information services are also available which give details on all its products and services. Contact the Information Centre. Tel: 020 8996 7111. Fax: 020 8996 7048.

Subscribing members of BSI are kept up to date with standards developments and receive substantial discounts on the purchase price of standards. For details of these and other benefits contact Membership Administration. Tel: 020 8996 7002. Fax: 020 8996 7001.

Copyright

Copyright subsists in all BSI publications. BSI also holds the copyright, in the UK, of the publications of the international standardization bodies. Except as permitted under the Copyright, Designs and Patents Act 1988 no extract may be reproduced, stored in a retrieval system or transmitted in any form or by any means – electronic, photocopying, recording or otherwise – without prior written permission from BSI.

This does not preclude the free use, in the course of implementing the standard, of necessary details such as symbols, and size, type or grade designations. If these details are to be used for any other purpose than implementation then the prior written permission of BSI must be obtained.

If permission is granted, the terms may include royalty payments or a licensing agreement. Details and advice can be obtained from the Copyright Manager. Tel: 020 8996 7070.