

Specification for

**100° Countersunk
precision head
aluminium and
aluminium alloy rivets***

ICS 49.030.60

*Index form of title: Rivets, 100° countersunk precision head, in L36, L37, L58 and L86 materials.

Foreword

Publishing information

BS 2SP 68 to BS 2SP 71:1973+A3:2015 is published by BSI Standards Limited, under licence from The British Standards Institution, and came into effect on 31 January 2015. It was prepared by Technical Committee ACE/12, *Aerospace Fasteners and Fastening*. A list of organizations represented on this committee can be obtained on request to its secretary.

Supersession

BS 2SP 68 to BS 2SP 71:1973+A3:2015 supersedes BS 2SP 68 to BS 2SP 71:1973 (incorporating Amendments No.1 and No.2) which is withdrawn.

Information about this document

The first issue of these British Standards marked a departure from the traditional method of dimensioning countersunk head rivets by means of toleranced dimensions for the head diameter, head thickness, land and angle. The method now adopted is known as the “flushness tolerance” method and was first used for countersunk fasteners in BS 1981, *Unified machine screws and machine screw nuts*. Its basic principles and advantages are outlined in Appendix A to this standard, which also gives details of suggested methods of gauging. The standards include the marking of rivets as agreed by ISO/TC 20 — Aircraft and space vehicles, and a method for the identification of undyed versions of the rivets.

Details of rivets with radiused tails for use in auto-riveting machines are given in Appendix B.

Text introduced or altered by Amendment No. 3 is indicated in the text by tags **A3** **A3**. Minor editorial changes are not tagged. Previous amendments are not indicated.

Presentational conventions

The provisions of this standard are presented in roman (i.e. upright) type. Its requirements are expressed in sentences in which the principal auxiliary verb is “shall”.

Commentary, explanation and general informative material is presented in smaller italic type, and does not constitute a normative element.

Contractual and legal considerations

This publication does not purport to include all the necessary provisions of a contract. Users are responsible for its correct application.

Compliance with a British Standard cannot confer immunity from legal obligations.

Summary of pages

This document comprises a front cover, an inside front cover, pages i and ii, pages 1 to 12 and a back cover.

This standard has been updated (see copyright date) and may have had amendments incorporated. This will be indicated in the amendment table on the inside front cover.

Amendments issued since publication

Amd. No.	Date	Comments
2388	November 1977	
3263	June 1980	
A3	January 2015	See Foreword

This British Standard, having been approved by the Aerospace Industry Standards Committee, was published under the authority of the Executive Board on 31 October 1973

© The British Standards Institution 2015
Published by BSI Standards Limited 2015

The following BSI references relate to the work on this standard:
Committee reference ACE/14
Drafts for approval
72/35871
13/30273386 DC

ISBN 978 0 580 81035 0

Contents

	Page
Foreword	Inside front cover
1 Scope	1
2 Material and manufacture	1
3 Condition of rivets	1
4 Dimensions	1
5 Protective finish	1
6 Gauging	1
7 Identification and marking	1
8 Inspection	2
9 Freedom from defects	2
10 Heat treatment of rivets	2
11 Packaging	3
Appendix A Principles of flushness control and recommended gauging practice	8
Appendix B Rivets for use in auto-riveting machines	11
Figure 1 — Dimensions of identification marks	3
Figure 2 — Rivet dimensions	3
Figure 2b — Enlarged view of head	4
Figure 3a — Diagram showing maximum and minimum head conditions	4
Figure 3b — Maximum and minimum head conditions	5
Figure 4 — Rivet dimensions	7
Figure 5 — Method of measurement of head protrusion	9
Figure 6 — Protrusion gauge block	10
Figure 7 — Detail of radiused tail	11
Table 1 — British Standard numbers, materials, finish and marking of 100° countersunk precision head aluminium and aluminium alloy rivets	3
Table 2 — Dimensions of 100° countersunk precision head aluminium and aluminium alloy rivets	3
Table 3 — Standard lengths and part numbers of 100° countersunk precision head aluminium and aluminium alloy rivets	7
Table 4 — Dimensions of gauge blocks	10
Table 5 — Dimensions of radiused tails	11

1 Scope

These British Standards specify the materials, dimensions, finish, marking and part numbers of 100° countersunk precision head aluminium and aluminium alloy rivets for aerospace use.

NOTE The figures in inch units are to be regarded as the standard. $\overline{A3}$ Accurate metric conversions should be based on the tables in BS 350. $\overline{A3}$

2 Material and manufacture

The rivets shall be manufactured from the appropriate material specified in Table 1 in the condition as supplied.

3 Condition of rivets

3.1 Rivets to BS SP 68 require no heat treatment.

3.2 Rivets to BS SP 69 require heat treatment in accordance with 10.1 and 10.2 before use.

3.3 Rivets to BS SP 70 require no heat treatment.

3.4 Rivets to BS SP 71 shall be finally heat treated by the rivet manufacturer in accordance with 10.3.

4 Dimensions

The rivets shall conform to the dimensions specified in Table 2 and Table 3.

5 $\overline{A3}$ Protective finish $\overline{A3}$

5.1 The rivets shall conform to the finish for the appropriate material specified in Table 1.

5.2 Anodic treatment shall be in accordance with the requirements of the latest issue of $\overline{A3}$ MoD Defence Equipment and Support Standard Def Stan 03-25 $\overline{A3}$.

5.3 Chemical oxidation shall be in accordance with the requirements of the latest issue of $\overline{A3}$ MoD Defence Equipment and Support Standard $\overline{A3}$ DTD 913.

5.4 Colouring shall be in accordance with the requirements of the latest issue of $\overline{A3}$ MoD Defence Equipment and Support Standard $\overline{A3}$ DTD 913, or other approved process e.g. $\overline{A3}$ Def Stan 03-25 $\overline{A3}$.

6 Gauging

The method of head dimensioning shown in Table 2 defines maximum and minimum head envelopes which control flushness in relation to a countersink of nominal dimensions.

The type of gauge in Figure 5 and Figure 6 is recommended as being suitable for flushness measurement, but the type of gauge to be used is not a mandatory requirement of this standard. The gauge shown in Figure 5 and Figure 6 does not control the head angle which will require to be checked at intervals during production. An additional gauge will be necessary for the absolute minimum head diameter.

7 Identification and marking

7.1 The marking of the rivets shall be as specified in Table 1, and shall be applied as follows.

- 1) Rivets over $\frac{3}{32}$ in diameter which do not exceed 8 diameters in length shall be marked on the shank end with the exception of the $\frac{1}{8}$ in diameter which may be marked on the head.
- 2) Rivets $\frac{1}{16}$ in and $\frac{3}{32}$ in diameter in all lengths, and rivets over $\frac{3}{32}$ in diameter which exceed 8 diameters in length, may be marked on either the head or the shank end.

The marking, whether indented or embossed, shall be clearly visible and the height or depth shall not exceed the following dimensions.

- 0.006 in on sizes up to and including $\frac{1}{8}$ in diameter;
- 0.008 in on sizes $\frac{5}{32}$ in and $\frac{3}{16}$ in diameter;
- 0.010 in on sizes $\frac{7}{32}$ in diameter and over.

7.2 Rivets identified by old-style markings may be supplied until existing stocks are consumed. The obsolescent markings are as follows.

Material	Marking
L 36	1
L 37	7
L 58	8
L 86	0

7.3 The rivets shall be identified for ordering purposes by the relevant British Standard number (see Table 1) and the appropriate part number (see Table 3), e.g. a rivet in L 58 material $\frac{3}{8}$ in diameter \times $\frac{5}{8}$ in length is $\boxed{A_3}$ SP70-410. $\boxed{A_3}$

7.4 Undyed versions of rivets shall be identified by their part number with the letter U in place of the dash.

7.5 Example of call-up:

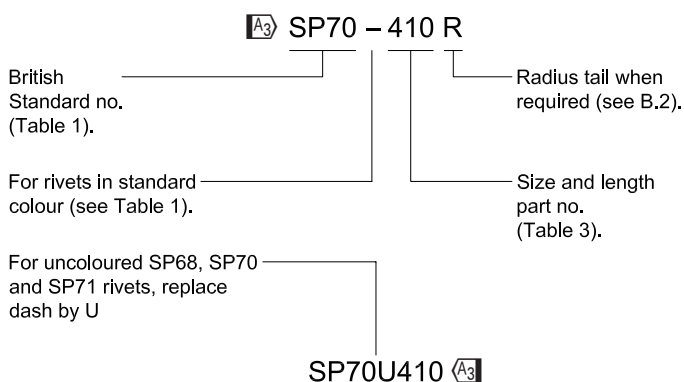

8 Inspection

It is recommended that inspection be by quality control methods designed to ensure that the manufacturing process is stable and that the rivets meet the requirements of the specification.

9 Freedom from defects

The rivets shall be free from harmful defects.

The rivets may be rejected at any time for faults in, or revealed by, manufacture, although they have been made from material passed previously for chemical composition and mechanical properties.

10 Heat treatment of rivets

10.1 Immediately before use or before refrigeration as described in 10.2, rivets to BS SP 69 shall be heated uniformly at a temperature of 495 ± 5 °C and quenched in water at a temperature not exceeding 40 °C.

10.2 Rivets to BS SP 69 commence to age harden immediately when kept at atmospheric temperature after quenching. Ageing may be delayed, however, by storing the rivets at low temperatures after quenching, and they may be expected to remain in a condition suitable for closing for a period depending on the storage temperature as shown below:

Temperature	Maximum storage period
0 °C to - 5 °C	45 hours
- 15 °C to - 20 °C	150 hours

The rivets shall be closed within two hours of solution treatment if kept at atmospheric temperature or within two hours of removal from cold storage.

10.3 Rivets to BS SP 71 shall be heat treated by the rivet manufacturer as follows.

Solution treat at a temperature of 495 ± 5 °C and quench in water at a temperature not exceeding 40 °C. Age at room temperature for not less than four days.

11 Packaging

Rivets shall be packaged, bagged or labelled and such packages, bags or labels shall bear the complete appropriate part number, e.g. SP68-408. See Table 3 for part numbers.

Table 1 — British Standard numbers, materials, finish and marking of 100° countersunk precision head aluminium and aluminium alloy rivets

British Standard no.	Material	Finish		Identification mark
	British Standard	Treatment	Colour	
BS SP 68	L 36 ^a	Anodic or chemical oxidation	Black	"T"
BS SP 69	L 37 ^a	None	Plain	— o — Embossed
BS SP 70	L 58 ^a	Anodic or chemical oxidation	Green	+ Embossed
BS SP 71	L 86 ^a		Violet	o Indented

NOTE Undyed versions of rivets of L 36, L 58 and L 86 and also available. See 7.4.
^a Latest issue.

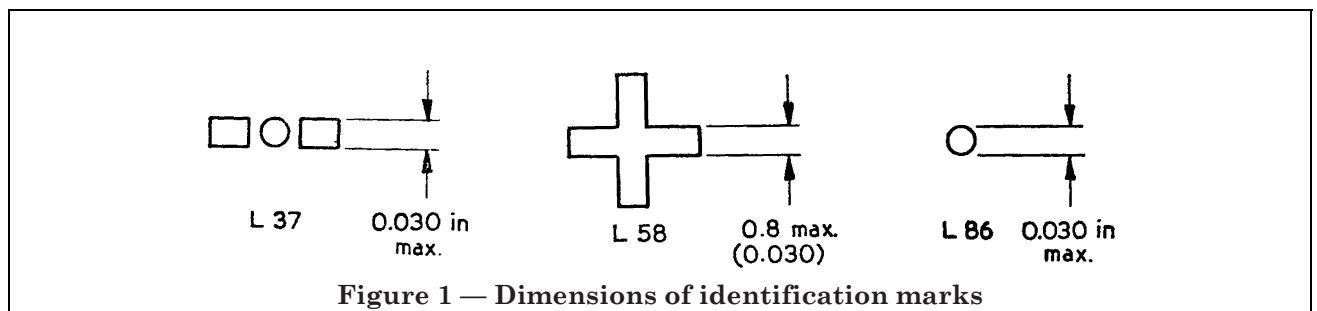

Table 2 — Dimensions of 100° countersunk precision head aluminium and aluminium alloy rivets

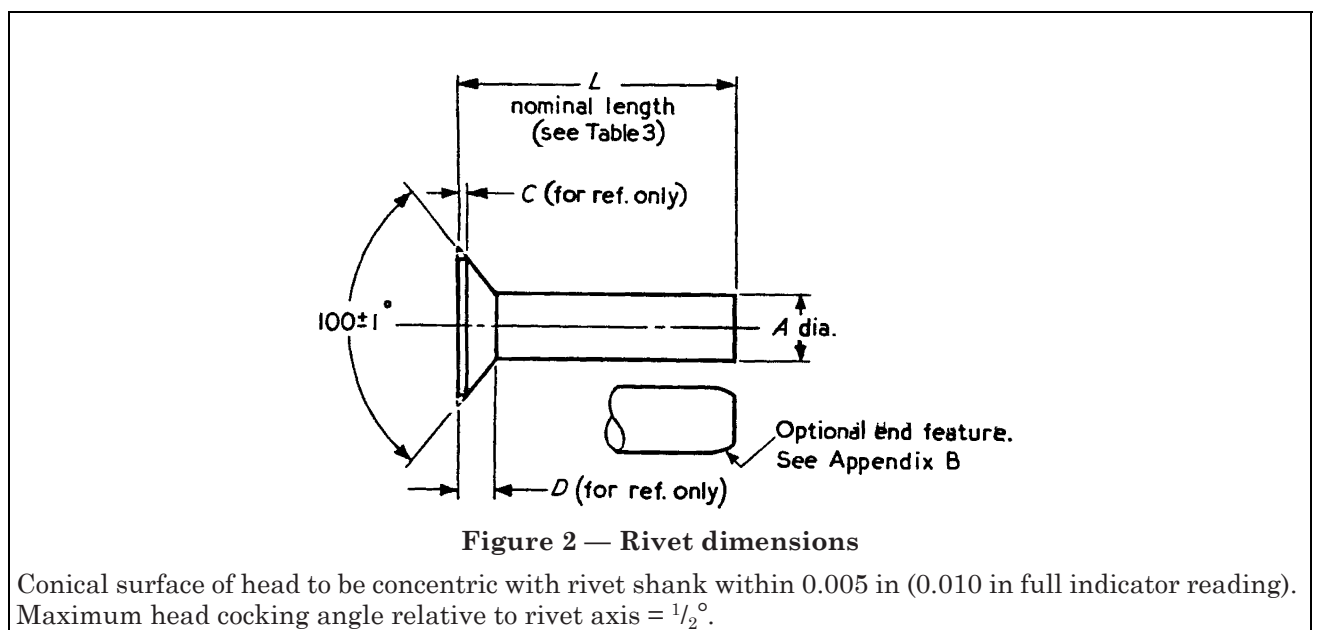

Table 2 — Dimensions of 100° countersunk precision head aluminium and aluminium alloy rivets

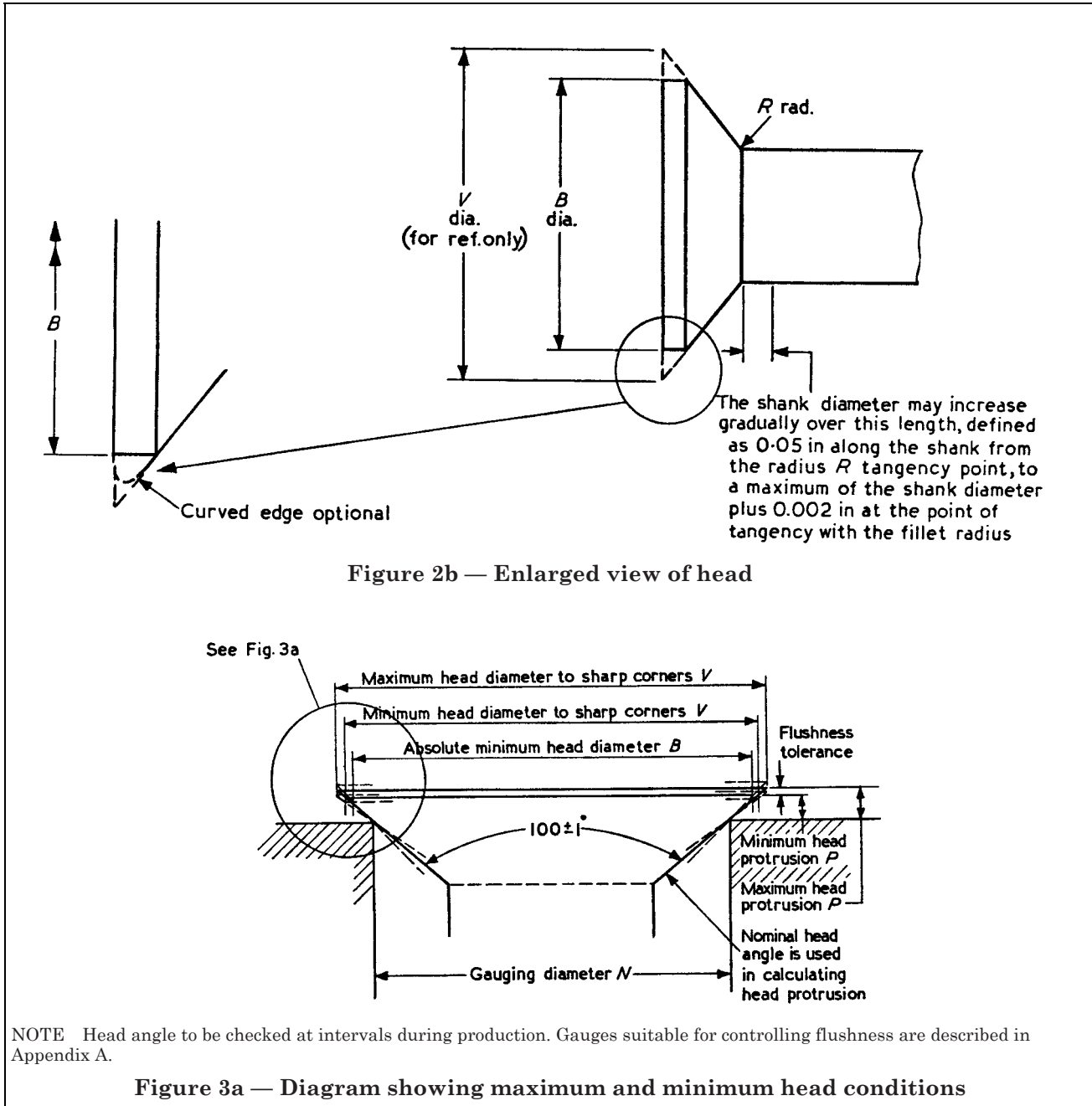

Table 2 — Dimensions of 100° countersunk precision head aluminium and aluminium alloy rivets

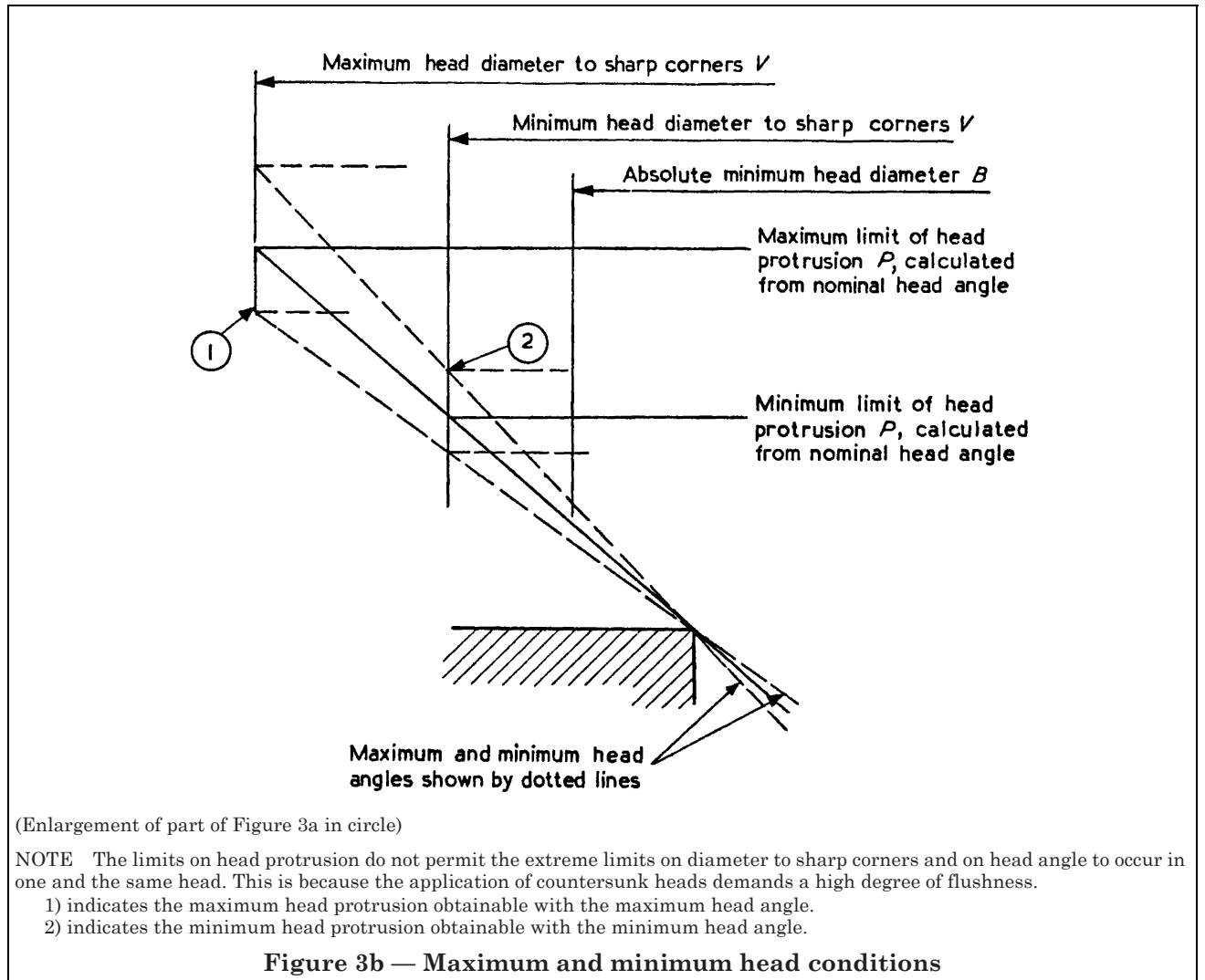

Table 2 — Dimensions of 100° countersunk precision head aluminium and aluminium alloy rivets

1 Nominal size of rivet	2 Diameter of shank, <i>A</i>		3		4		5		6		7		8		9		10				11		12		13		14		
	max.	min.	Diameter of head				Nominal depth of head, <i>D</i> (Reference only)	Depth of land, <i>C</i>	Gauging diameter, <i>N</i>	Head protrusion				Flushness tolerance, (<i>P</i> max., - <i>P</i> min.)	Radius under head, <i>R</i>														
			To sharp corners, <i>V</i> (reference only)		Absolute min., <i>B</i>					Protrusion above gauging diameter, <i>P</i>		min.			max.		max.		min.										
in	in	in	in	in	in	in	in	in	in	in	in	in	in	in	in	in	in	in	in	in	in	in	in	in	in	in	in	in	
1/16 (0.062)	0.065	0.061	0.1170	0.1110	0.104	0.022	0.006	0.097	0.0084	0.0059	0.0025	0.020	0.010	0.0025	0.020	0.010	0.0025	0.0084	0.0059	0.0025	0.020	0.010	0.0025	0.020	0.010	0.0025	0.020	0.010	0.0025
3/32 (0.094)	0.097	0.093	0.1825	0.1755	0.164	0.036	0.008	0.151	0.0132	0.0103	0.0029	0.008	0.008	0.151	0.0132	0.0103	0.0029	0.0132	0.0103	0.0029	0.020	0.010	0.0029	0.020	0.010	0.0029	0.020	0.010	0.0029
1/8 (0.125)	0.128	0.124	0.2285	0.2215	0.208	0.042	0.009	0.192	0.0153	0.0124	0.0029	0.009	0.009	0.192	0.0153	0.0124	0.0029	0.0153	0.0124	0.0029	0.020	0.010	0.0029	0.020	0.010	0.0029	0.020	0.010	0.0029
5/32 (0.156)	0.159	0.155	0.2900	0.2820	0.267	0.055	0.010	0.243	0.0197	0.0164	0.0033	0.010	0.010	0.243	0.0197	0.0164	0.0033	0.0197	0.0164	0.0033	0.020	0.010	0.0033	0.020	0.010	0.0033	0.020	0.010	0.0033
3/16 (0.187)	0.190	0.186	0.3575	0.3485	0.329	0.070	0.012	0.298	0.0250	0.0212	0.0038	0.012	0.012	0.298	0.0250	0.0212	0.0038	0.0250	0.0212	0.0038	0.020	0.010	0.0038	0.020	0.010	0.0038	0.020	0.010	0.0038
7/32 (0.219)	0.222	0.218	0.419	0.410	0.386	0.082	0.014	0.350	0.0289	0.0251	0.0038	0.014	0.014	0.350	0.0289	0.0251	0.0038	0.0289	0.0251	0.0038	0.030	0.015	0.0038	0.030	0.015	0.0038	0.030	0.015	0.0038
1/4 (0.250)	0.253	0.249	0.4805	0.4715	0.445	0.095	0.015	0.401	0.0334	0.0296	0.0038	0.015	0.015	0.401	0.0334	0.0296	0.0038	0.0334	0.0296	0.0038	0.030	0.015	0.0038	0.030	0.015	0.0038	0.030	0.015	0.0038
5/16 (0.312)	0.315	0.311	0.5690	0.5590	0.526	0.106	0.018	0.480	0.0373	0.0331	0.0042	0.018	0.018	0.480	0.0373	0.0331	0.0042	0.0373	0.0331	0.0042	0.030	0.015	0.0042	0.030	0.015	0.0042	0.030	0.015	0.0042
3/8 (0.375)	0.378	0.374	0.6995	0.6885	0.650	0.134	0.020	0.588	0.0468	0.0422	0.0046	0.020	0.020	0.588	0.0468	0.0422	0.0046	0.0468	0.0422	0.0046	0.030	0.015	0.0046	0.030	0.015	0.0046	0.030	0.015	0.0046

NOTES The following notes on the dimensions shown in Table 2, with particular reference to their relationship with those shown in the American Standard for rivets MS 20426 are given for information.

- Shank diameter.* The maximum dimensions conform to nominal + 0.003 in and the minimum dimensions to nominal - 0.001 in as in MS 20426 to provide for the aircraft constructor's requirements for a close fit between the rivet shank and the drilled hole.
- Maximum and minimum head diameter to sharp corners.* The dimensions are based on those of MS 20426 but with slight variations to allow for a progressive, tolerance between the maximum and minimum head diameter to sharp corners. The tolerance on the smallest size is 0.006 in and on the largest size is 0.011 in. MS 20426 specifies a tolerance of 0.008 in throughout. The dimensions are for reference only.
- Absolute minimum head diameter.* This dimension is not specified in MS 20426. The dimensions in column 6 have been calculated from a progressive depth of land which is considered necessary for forging.
- Nominal head depth.* The dimensions are for reference only and have been calculated as the mean between maximum and minimum head depth, corresponding to maximum and minimum diameters to sharp corners, the head angle and shank diameter being taken as nominal.
- Maximum depth of land* (See Note 3). These dimensions are for reference only.
- Gauging diameter.* This is a fundamental dimension and it is essential that it be used in gauging, whether by flushness gauge (Figure 5 and Figure 6) or by optical projection.
- Head protrusion.* Similarly, these dimensions must be used in gauging whether by flushness gauge (Figure 5 and Figure 6) or by optical projection. The maximum head protrusion has been calculated from the maximum head diameter to sharp corners, the gauging diameter and the nominal head angle, and the minimum head protrusion has been calculated from the minimum head diameter to sharp corners, the gauging diameter and the nominal head angle. The gauging diameter and flushness tolerance have been chosen to give a head of comparable precision to that of MS 20426.

Table 3 — Standard lengths and part numbers of 100° countersunk precision head aluminium and aluminium alloy rivets

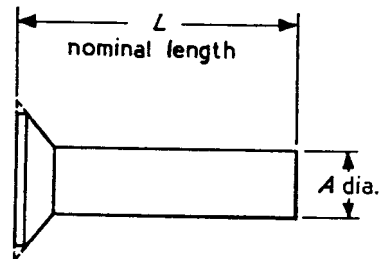

Figure 4 — Rivet dimensions

Nominal length, L^a ± 0.010 in	Nominal diameter, A , in inches								
	$\frac{1}{16}$	$\frac{3}{32}$	$\frac{1}{8}$	$\frac{5}{32}$	$\frac{3}{16}$	$\frac{7}{32}$	$\frac{1}{4}$	$\frac{5}{16}$	$\frac{3}{8}$
	Part number The last two figures of the part numbers denote the length in $\frac{1}{16}$ in, the remaining figure or figures denoting the diameter in $\frac{1}{32}$ in.								
in									
$\frac{1}{8}$	202	302							
$\frac{3}{16}$	203	303	403						
$\frac{1}{4}$	204	304	404	504					
$\frac{5}{16}$	205	305	405	505	605				
$\frac{3}{8}$	206	306	406	506	606	706	806		
$\frac{7}{16}$	207	307	407	507	607	707	807	1 007	
$\frac{1}{2}$	208	308	408	508	608	708	808	1 008	1 208
$\frac{9}{16}$	209	309	409	509	609	709	809	1 009	1 209
$\frac{5}{8}$	210	310	410	510	610	710	810	1 010	1 210
$a\frac{11}{16}$	$a211$	$a311$	$a411$	$a511$	$a611$	$a711$	$a811$	$a1 011$	$a1 211$
$\frac{3}{4}$	$a212$	312	412	512	612	712	812	1 012	1 212
$a\frac{13}{16}$	$a213$	$a313$	$a413$	$a513$	$a613$	$a713$	$a813$	$a1 013$	$a1 213$
$\frac{7}{8}$	$a214$	314	414	514	614	714	814	1 014	1 214
$a\frac{16}{16}$	$a215$	$a315$	$a415$	$a515$	$a615$	$a715$	$a815$	$a1 015$	$a1 215$
1	$a216$	316	416	516	616	716	816	1 016	1 216
$1\frac{1}{8}$		$a318$	418	518	618	718	818	1 018	1 218
$1\frac{1}{4}$		$a320$	420	520	620	720	820	1 020	1 220
$1\frac{3}{8}$		$a322$	422	522	622	722	822	1 022	1 222
$1\frac{1}{2}$		$a324$	424	524	624	724	824	1 024	1 224
$1\frac{3}{4}$			428	528	628	728	828	1 028	1 228
2				532	632	732	832	1 032	1 232
$2\frac{1}{2}$					640	740	840	1 040	1 240
3					648	748	848	1 048	1 248

NOTE For details of rivets with radiused tails see Appendix B. The maximum available lengths of radiused tail rivets are indicated in Table 3 by the broken line in each nominal diameter column. The maximum nominal length L available for each nominal diameter A is the length corresponding to the part number immediately above the broken line.

^a Non-preferred sizes.

Appendix A Principles of flushness control and recommended gauging practice

A.1 The major requirement of the user of a countersunk head rivet is that the upper surface of the head should fit with as great degree of flushness as possible with the surface into which it is inserted. This flushness is dependent upon both the tolerance on the head of the rivet and that of the countersink into which the head is fitted. The method of dimensioning adopted in this standard directly controls the flushness accuracy of the rivet in relation to a nominal countersink, the result in an actual assembly being dependent upon the tolerance applied to the countersink, which is outside the scope of this standard.

A.2 In the traditional method of dimensioning countersunk head rivets, the limits on the rivet head thickness are affected by the tolerance on the shank diameter. This however is of no consequence in the matter of flushness and it would be necessary, for any degree of flushness, to exercise a closer control on head thickness and/or shank diameter if the traditional dimensioning methods were used.

A.3 The recommended methods of gauging flushness are simple and do not call for any measurement of difficult or dubious dimensions.

A.4 The most important aspect of the rivet head in the attainment of flushness is the position of the flat upper surface of the head in relation to the conical under surface. The gauging dimension by which this is controlled is that between the flat upper surface and a plane which cuts the conical surface of the head normal to its axis at a specified diameter known as the gauging diameter (see Figure 3a). The dimension gauged is known as head protrusion and its tolerance as the flushness tolerance.

A.5 The variables which affect the flushness tolerance are:

- 1) the diameter to sharp corners, formed by the hypothetical intersection of the flat upper surface of the head and the conical under surface;
- 2) the included angle of the head;
- 3) the concentricity of the head and the shank.

The gauging diameter is at approximately one-third of the head depth from the upper surface.

A.6 The elements which define the rivet head and are required to be controlled by inspection are:

- 1) head protrusion, the limits of which define the flushness tolerance;
- 2) diameter of head to sharp corners; this is controlled indirectly by the inspection of 1) and 4);
- 3) actual diameter of head for which a minimum is specified and which is the diameter at the land;
- 4) included angle of the conical under surface;
- 5) radius between conical surface and shank.

It is not a requirement of this standard that a particular method of inspection shall be employed. Head protrusion may be checked by means of a gauge of the type shown in Figure 5, by a GO — NOT GO gauge, by optical projection, or by any other suitable means. The actual diameter may be checked by direct measurement or by a GO — NOT GO gauge. The head angle and radius at shank may be checked by optical projection.

A.7 Figure 5 illustrates a type of gauge which has achieved some popularity for use with aircraft countersunk head bolts and rivets in the USA. Details of a suitable gauge block are given in Figure 6.

The intersection of the hole “X” with the top surface of the gauge block forms the diameter on which the cone of the rivet head rests. The diameter of the hole “X” is slightly less than the gauging diameter N to permit the edge of the hole to be broken to form a land approximately 0.003 in wide by lapping with a hardened steel ball until the dimension Z is within the stated limits. Z is calculated from the formula:

$$Z = \frac{1}{2} \left(Y + \sqrt{Y^2 - N^2} \right).$$

When the rivet is inserted in the block, the dial indicator is used to give a direct reading of head protrusion which is the amount by which the top surface of the rivet protrudes above the top surface of the gauge block.

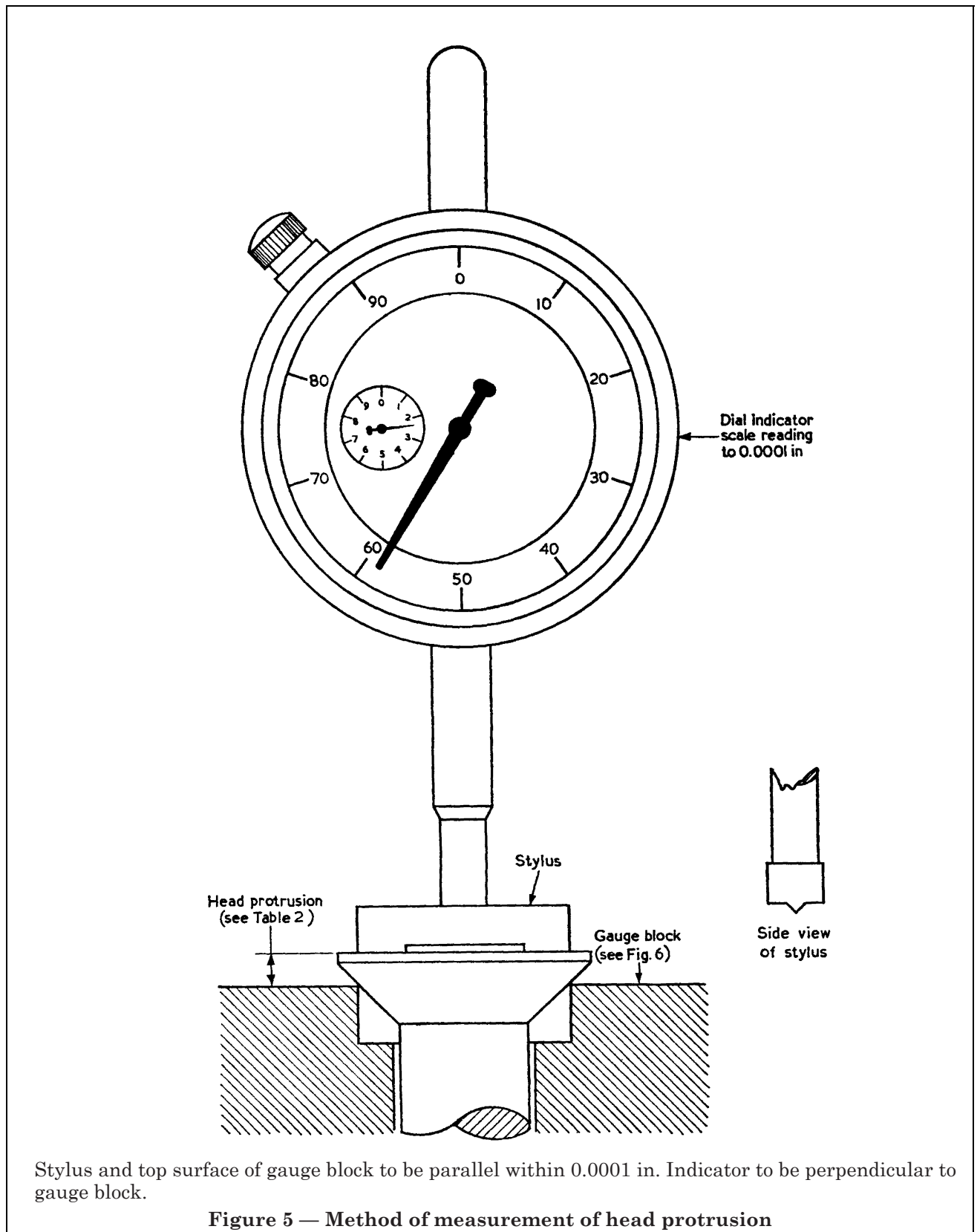
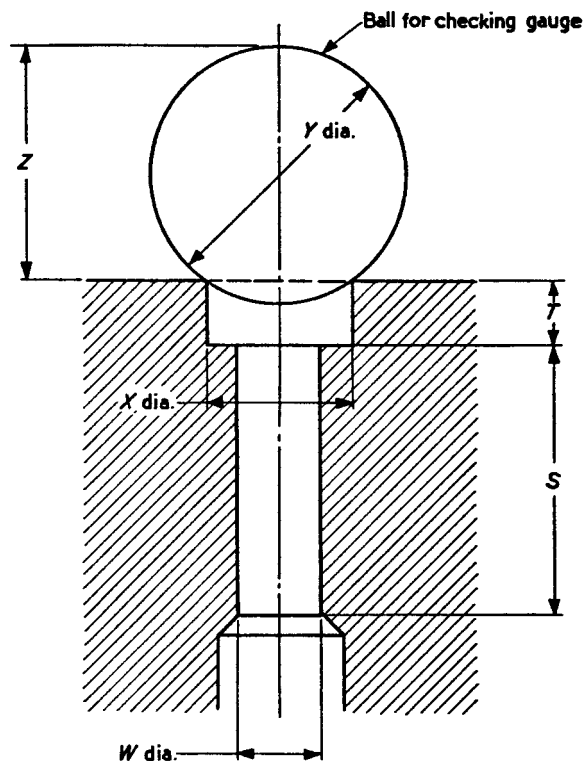

Table 4 — Dimensions of gauge blocks



Diameters X and W to be concentric within 0.001 in full indicator reading.

Section through gauge block.

Figure 6 — Protrusion gauge block (see Figure 5 and A.7.)

Nominal size of rivet	Ball dia., Y	C/bore dia., X	Ball protrusion, Z^a	Depth of counterbore, T	Dia. of guide, W	Length of guide, S	Min. depth of gauge block for max. length rivet
	Nominal	+0 -0.001	+0.0002 -0	+0.010 -0	+0.001 -0	± 0.010	
in	in	in	in	in	in	in	in
$1/16$	0.15625 ($5/32$)	0.093	0.1394	0.125	0.066	0.100	1
$3/22$	0.2362 (6 mm)	0.147	0.2089	0.140	0.099	0.150	$1\frac{1}{2}$
$1/8$	0.3125 ($5/16$)	0.188	0.2795	0.150	0.130	0.200	$1\frac{3}{4}$
$5/32$	0.3750 ($3/8$)	0.239	0.3303	0.160	0.162	0.250	2
$3/16$	0.46875 ($15/32$)	0.294	0.4153	0.175	0.194	0.300	3
$7/32$	0.5625 ($9/16$)	0.346	0.5014	0.190	0.226	0.350	3
$1/4$	0.6250 ($5/8$)	0.397	0.5522	0.200	0.257	0.400	3
$5/16$	0.750 ($3/4$)	0.476	0.6631	0.210	0.319	0.500	3
$3/8$	0.9375 ($15/16$)	0.584	0.8338	0.240	0.382	0.600	3

^a For the basis of calculation of this dimension see A.7.

Appendix B Rivets for use in auto-riveting machines

B.1 With the advent of auto-riveting machines, it is necessary to form the rivet tail with a small radius. Conventional methods of riveting are unaffected by this feature.

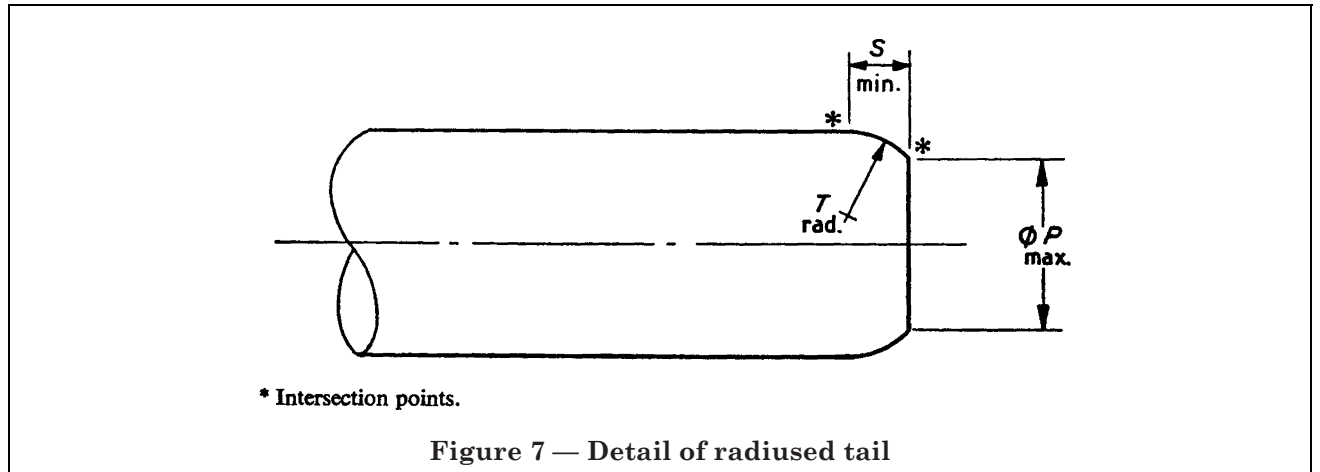

Table 5 — Dimensions of radiused tails

Nominal diameter	<i>S</i> min.	<i>T</i> rad. ± 0.010 in.	Dia. <i>P</i> max.
in	in	in	in
1/16	0.011	0.019	0.053
3/32	0.018	0.029	0.078
1/8	0.026	0.039	0.102
5/32	0.034	0.049	0.128
3/16	0.042	0.059	0.153
7/32	0.049	0.069	0.180
1/4	0.057	0.078	0.202
5/16	0.073	0.098	0.248
3/8	0.089	0.117	0.294

B.2 Rivets of standard lengths and diameters, up to the maximum available lengths indicated by the broken lines shown in Table 3, may be supplied with radius tails on request. The method of call-up is given in 7.5.

Text deleted.

British Standards Institution (BSI)

BSI is the national body responsible for preparing British Standards and other standards-related publications, information and services.

BSI is incorporated by Royal Charter. British Standards and other standardization products are published by BSI Standards Limited.

About us

We bring together business, industry, government, consumers, innovators and others to shape their combined experience and expertise into standards-based solutions.

The knowledge embodied in our standards has been carefully assembled in a dependable format and refined through our open consultation process. Organizations of all sizes and across all sectors choose standards to help them achieve their goals.

Information on standards

We can provide you with the knowledge that your organization needs to succeed. Find out more about British Standards by visiting our website at bsigroup.com/standards or contacting our Customer Services team or Knowledge Centre.

Buying standards

You can buy and download PDF versions of BSI publications, including British and adopted European and international standards, through our website at bsigroup.com/shop, where hard copies can also be purchased.

If you need international and foreign standards from other Standards Development Organizations, hard copies can be ordered from our Customer Services team.

Subscriptions

Our range of subscription services are designed to make using standards easier for you. For further information on our subscription products go to bsigroup.com/subscriptions.

With **British Standards Online (BSOL)** you'll have instant access to over 55,000 British and adopted European and international standards from your desktop. It's available 24/7 and is refreshed daily so you'll always be up to date.

You can keep in touch with standards developments and receive substantial discounts on the purchase price of standards, both in single copy and subscription format, by becoming a **BSI Subscribing Member**.

PLUS is an updating service exclusive to BSI Subscribing Members. You will automatically receive the latest hard copy of your standards when they're revised or replaced.

To find out more about becoming a BSI Subscribing Member and the benefits of membership, please visit bsigroup.com/shop.

With a **Multi-User Network Licence (MUNL)** you are able to host standards publications on your intranet. Licences can cover as few or as many users as you wish. With updates supplied as soon as they're available, you can be sure your documentation is current. For further information, email bsmusales@bsigroup.com.

BSI Group Headquarters

389 Chiswick High Road London W4 4AL UK

Revisions

Our British Standards and other publications are updated by amendment or revision.

We continually improve the quality of our products and services to benefit your business. If you find an inaccuracy or ambiguity within a British Standard or other BSI publication please inform the Knowledge Centre.

Copyright

All the data, software and documentation set out in all British Standards and other BSI publications are the property of and copyrighted by BSI, or some person or entity that owns copyright in the information used (such as the international standardization bodies) and has formally licensed such information to BSI for commercial publication and use. Except as permitted under the Copyright, Designs and Patents Act 1988 no extract may be reproduced, stored in a retrieval system or transmitted in any form or by any means – electronic, photocopying, recording or otherwise – without prior written permission from BSI. Details and advice can be obtained from the Copyright & Licensing Department.

Useful Contacts:

Customer Services

Tel: +44 845 086 9001

Email (orders): orders@bsigroup.com

Email (enquiries): cservices@bsigroup.com

Subscriptions

Tel: +44 845 086 9001

Email: subscriptions@bsigroup.com

Knowledge Centre

Tel: +44 20 8996 7004

Email: knowledgecentre@bsigroup.com

Copyright & Licensing

Tel: +44 20 8996 7070

Email: copyright@bsigroup.com



...making excellence a habit.™