



BSI Standards Publication

**Refrigerated non-petroleum
based liquefied gaseous fuels
— Dimethylether (DME) —
Method of manual sampling
onshore terminals**

National foreword

This British Standard is the UK implementation of ISO 29945:2016. It supersedes BS ISO 29945:2009 which is withdrawn.

The UK participation in its preparation was entrusted to Technical Committee PTI/12, Petroleum Measurement and Sampling.

A list of organizations represented on this committee can be obtained on request to its secretary.

This publication does not purport to include all the necessary provisions of a contract. Users are responsible for its correct application.

© The British Standards Institution 2016.
Published by BSI Standards Limited 2016

ISBN 978 0 580 91064 7

ICS 75.180.30

Compliance with a British Standard cannot confer immunity from legal obligations.

This British Standard was published under the authority of the Standards Policy and Strategy Committee on 30 November 2016.

Amendments/corrigenda issued since publication

Date	Text affected
------	---------------

INTERNATIONAL
STANDARD

ISO
29945

Second edition
2016-11-15

**Refrigerated non-petroleum
based liquefied gaseous fuels —
Dimethylether (DME) — Method of
manual sampling onshore terminals**

*Combustibles gazeux non pétroliers liquéfiés réfrigérés —
Diméthyléther (DME) — Méthode d'échantillonnage manuel sur des
terminaux à terre*



Reference number
ISO 29945:2016(E)

© ISO 2016



COPYRIGHT PROTECTED DOCUMENT

© ISO 2016, Published in Switzerland

All rights reserved. Unless otherwise specified, no part of this publication may be reproduced or utilized otherwise in any form or by any means, electronic or mechanical, including photocopying, or posting on the internet or an intranet, without prior written permission. Permission can be requested from either ISO at the address below or ISO's member body in the country of the requester.

ISO copyright office
Ch. de Blandonnet 8 • CP 401
CH-1214 Vernier, Geneva, Switzerland
Tel. +41 22 749 01 11
Fax +41 22 749 09 47
copyright@iso.org
www.iso.org

Contents

Page

Foreword	iv
Introduction	v
1 Scope	1
2 Normative references	1
3 Terms and definitions	1
4 Chemical and physical properties of DME	2
4.1 General characteristics.....	2
4.2 Chemical and physical properties.....	2
5 Precautions	2
5.1 General.....	2
5.2 Safety precautions.....	2
5.3 General precautions for sample cylinders.....	3
5.4 Sampling point.....	3
6 Sampling system	3
6.1 Apparatus used for sampling.....	3
6.2 Materials and structure of sampling line and sample cylinders.....	5
6.2.1 General.....	5
6.2.2 Sampling line.....	5
6.2.3 Sample cylinder.....	5
7 Sampling	6
7.1 Terminal in a loading port.....	6
7.2 Terminal in an unloading port.....	6
8 Preparation for sampling	6
8.1 Visual inspection of sampling line and sample cylinder.....	6
8.2 Connection of the apparatus.....	6
8.3 Purging the sampling line and sample cylinder.....	6
9 Sampling procedure	7
9.1 General.....	7
9.2 Two-valve sample cylinder with or without ullage tube.....	7
9.3 Single-valve sample cylinder.....	7
9.4 Two-valve sample cylinder with a siphon tube.....	7
10 Adjustment of sample volume	8
10.1 Two-valve sample cylinder without ullage tube.....	8
10.2 Two-valve sample cylinder with ullage tube.....	8
10.3 Single-valve sample cylinder.....	8
10.4 Two-valve sample cylinder with a siphon tube.....	8
11 Checking for leakage	9
12 Number of samples	9
13 Identification of sample cylinder	9
14 Retention of samples	10
Bibliography	11

Foreword

ISO (the International Organization for Standardization) is a worldwide federation of national standards bodies (ISO member bodies). The work of preparing International Standards is normally carried out through ISO technical committees. Each member body interested in a subject for which a technical committee has been established has the right to be represented on that committee. International organizations, governmental and non-governmental, in liaison with ISO, also take part in the work. ISO collaborates closely with the International Electrotechnical Commission (IEC) on all matters of electrotechnical standardization.

The procedures used to develop this document and those intended for its further maintenance are described in the ISO/IEC Directives, Part 1. In particular the different approval criteria needed for the different types of ISO documents should be noted. This document was drafted in accordance with the editorial rules of the ISO/IEC Directives, Part 2 (see www.iso.org/directives).

Attention is drawn to the possibility that some of the elements of this document may be the subject of patent rights. ISO shall not be held responsible for identifying any or all such patent rights. Details of any patent rights identified during the development of the document will be in the Introduction and/or on the ISO list of patent declarations received (see www.iso.org/patents).

Any trade name used in this document is information given for the convenience of users and does not constitute an endorsement.

For an explanation on the meaning of ISO specific terms and expressions related to conformity assessment, as well as information about ISO's adherence to the World Trade Organization (WTO) principles in the Technical Barriers to Trade (TBT) see the following URL: www.iso.org/iso/foreword.html.

The committee responsible for this document is ISO/TC 28, *Petroleum products and related products of synthetic or biological origin*, Subcommittee SC 5, *Measurement of refrigerated hydrocarbon and non-petroleum based liquefied gaseous fuels*.

This second edition cancels and replaces the first edition (ISO 29945:2009), which has been technically revised.

Introduction

Measures for environmental protection are required on a global scale. In this context, various methods of achieving these aims have been independently studied or undertaken in many countries. One such project, the development of the use of dimethylether (DME) as a new form of energy, has been undertaken in several countries. The use of DME generates neither sulfur oxide nor any other particulate matter known to cause environmental pollution at the time of combustion.

Another benefit of the use of DME as a petroleum alternative is that it can be produced easily from natural gases, coals and biomasses with only slight additional development of the existing techniques of production, transportation, storage and consumption.

In international trade, especially bulk transportation by sea, DME is liquefied by either refrigeration or pressurization and transported using ocean-going DME tankers and/or LPG tankers. To detect qualitative deterioration of the DME that can take place during transportation or storage, the establishment of an International Standard, agreed to by all concerned nations and parties, is required.

This document specifies a method of manual sampling of DME liquefied by refrigeration for analysis to define and/or confirm adherence to contractual specifications.

Refrigerated non-petroleum based liquefied gaseous fuels — Dimethylether (DME) — Method of manual sampling onshore terminals

1 Scope

This document specifies a manual sampling method for refrigerated liquefied DME at terminals in both loading and unloading ports along with precautions.

This document does not include recommendations for the location of a sampling point in a line or vessel.

This document is also applicable to the following cases, with necessary modifications:

- sampling of DME on board liquefied gas tankers where appropriate sampling apparatus is provided;
- sampling of other refrigerated, non-petroleum-based, liquefied gaseous fuels whose chemical and physical properties are similar to those of DME.

The detailed chemical and physical properties of DME differ from those of LPG, which suggests that DME requires precautions different from those of LPG. However, their basic properties are similar to each other and so general reference is made in this document to precautions for LPG that have been applied in many countries. Reference can also be made to the appropriate individual items in this document for precautions concerning the quality.

2 Normative references

There are no normative references in this document.

3 Terms and definitions

For the purposes of this document, the following terms and definitions apply.

ISO and IEC maintain terminological databases for use in standardization at the following addresses:

- IEC Electropedia: available at <http://www.electropedia.org/>
- ISO Online browsing platform: available at <http://www.iso.org/obp>

3.1

sampling line

line used to connect a *sample probe* (3.2) and a sample cylinder

3.2

sample probe

device inserted into gas or liquid to be sampled from the transfer line or fitted to the transfer line for collecting a sample

[SOURCE: ISO 1988-6:2000, 6.40.104]

3.3

ullage tube

outage tube

tube fitted in a sample cylinder in order to easily adjust volume of the DME vapour

4 Chemical and physical properties of DME

4.1 General characteristics

DME has the following general characteristics, which should be considered with respect to personal safety precautions.

- a) It is non-corrosive.
- b) It has a relatively small coefficient of thermal expansion.
- c) It acts as an effective solvent for many materials.
- d) It is hydrophilic.

4.2 Chemical and physical properties

DME has the following general chemical and physical properties:

- | | |
|--|------------------------------------|
| a) boiling point (at atmospheric pressure) | -25,1 °C; |
| b) saturated vapour pressure (at 25 °C) | 0,61 MPa; |
| c) explosive range | 3,4 % to 27,0 % volume fraction; |
| d) gas density (relative to air) | 1,59; |
| e) liquid density (at 20 °C) | 670 kg/m ³ ; |
| f) chemical structure | (CH ₃) ₂ O; |
| g) molecular weight | 46,07 g mol ⁻¹ ; |
| h) auto ignition temperature | 350 °C. |

5 Precautions

5.1 General

[Clause 5](#) introduces the safety precautions that should be observed at the time of sampling and general precautions for the sample cylinders being used. It is the responsibility of the user of this document to ensure that the procedure of sampling meets the applicable safety regulations.

5.2 Safety precautions

5.2.1 Wear appropriate protective clothing, helmet, goggles, gloves and safety work shoes.

5.2.2 Stand upwind and complete sampling in short a time as practicable.

5.2.3 Sampling work should be performed by skilled and experienced staff, or carried out under the supervision of such staff.

5.2.4 While in use, sample equipment should be grounded against generation of static electricity.

5.2.5 In-house safety instructions should be applied.

5.3 General precautions for sample cylinders

5.3.1 The sample cylinders used should conform to any requirements, for example, periodic inspections, that are required by the regulatory authority and should be used within the validity period of the test certificate.

5.3.2 Even if the sample cylinders being used are under the period of validity/conformity, sample cylinders showing any apparent damage shall not be used.

5.4 Sampling point

Sampling points shall be located so as to obtain representative samples. To prevent vaporization of DME in the line before sampling, it is preferable to locate the sampling point at a place where the pressure and temperature of the DME in the line are constant.

6 Sampling system

6.1 Apparatus used for sampling

The apparatus used for sampling shall consist of a sampling line and sample cylinder. Typical types of apparatus are shown in [Figures 1 to 3](#).

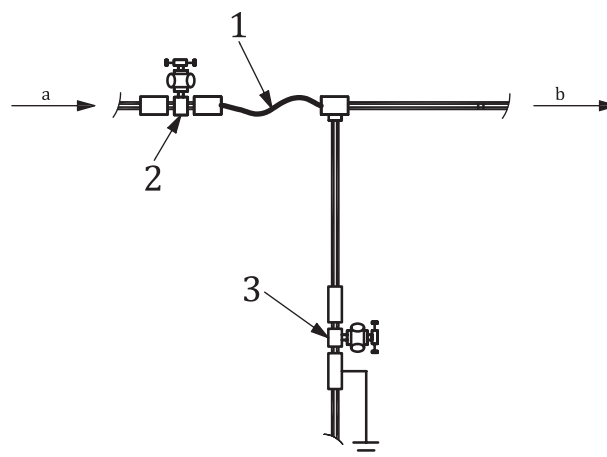

Key

- 1 sampling line
- 2 control valve
- 3 exhaust valve
- a DME.
- b To sample cylinder.

Figure 1 — Example of typical sampling line

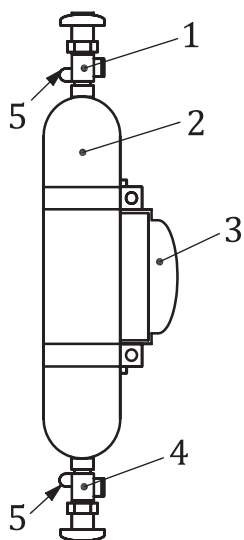

a) Two-valve sample cylinder

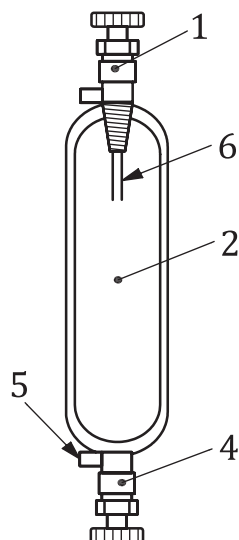

b) Two-valve sample cylinder with an ullage tube

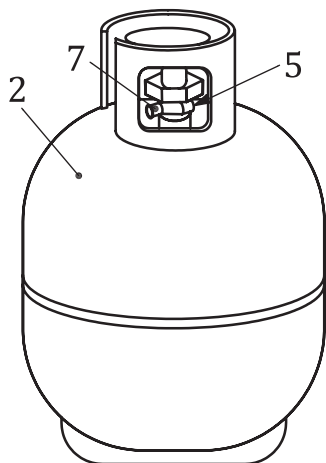

c) Single-valve sample cylinder

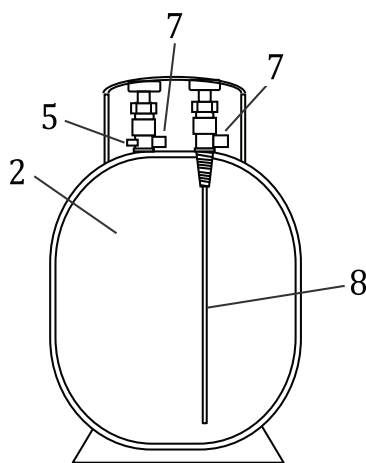

d) Two-valve sample cylinder with a siphon tube

Key

- 1 outlet valve
- 2 sampling cylinder
- 3 handle
- 4 inlet valve
- 5 safety valve
- 6 ullage tube
- 7 inlet/outlet valve
- 8 siphon tube (to take out a liquid-phase sample)

Figure 2 — Examples of typical sample cylinders

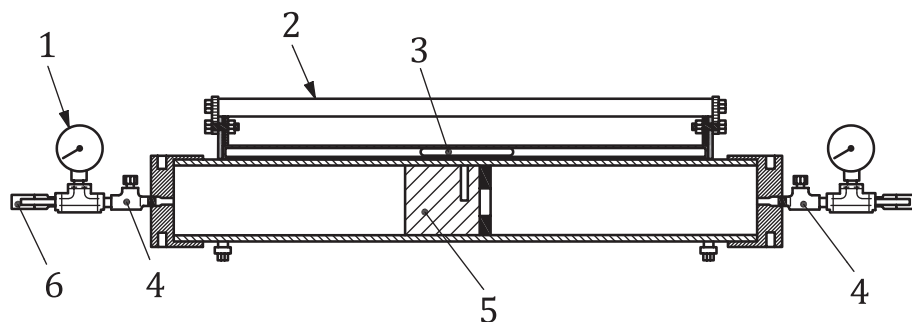
**Key**

- 1 pressure gauge
- 2 carrying handle
- 3 magnetic indicator
- 4 rupture discs for pressure protection
- 5 floating piston
- 6 valve

Figure 3 — Example of a floating-piston sample cylinder

6.2 Materials and structure of sampling line and sample cylinders

6.2.1 General

The chemical and physical properties of DME shall be taken into consideration when the materials of the sampling line and sample cylinders are selected. Stainless steel is suggested as one of the most suitable materials. In addition, because of the solvent property of DME, parts used in the sampling line and sample cylinders shall be made of high-polymer materials that are resistant during long-term use.

6.2.2 Sampling line

The sampling line shall be made of flexible stainless steel with an exhaust valve. As an example, a typical sampling line is shown in [Figure 1](#). The purpose of the sampling line is to transfer a DME sample obtained from the receiving/delivery line to the sample cylinder, while maintaining it in a liquid state.

Therefore, to prevent vaporization of the sample due to heat input during transfer, the tube should be as short in length and small in calibre as practicable, and the outside should be insulated.

6.2.3 Sample cylinder

6.2.3.1 Basic design

Two-valve sample cylinders with or without an ullage tube are most advisable, however, single-valve sample cylinders are also suitable for samples being kept for future reference. Sample cylinders shall be equipped with a safety valve or a rupture disc to prevent over-pressurization.

If an ullage tube is fitted, the following shall be considered with respect to its design:

- when the filling is completed, the ullage tube remains in the gas phase;
- the corresponding liquid inside the cylinder represents 85 % of the total volume.

NOTE After filling DME in a sample cylinder with an ullage tube, if the outlet valve is opened, fluid is released, first in a liquid state, then in a gaseous state. The liquid remaining in the sample cylinder at this time is estimated to occupy 85 % of the total volume.

6.2.3.2 Identification

Cylinder number with the allowable pressure shall be identified. In addition, where applicable, the valve to which the ullage tube is attached shall be marked.

6.2.3.3 Capacity

Capacity of the sample cylinder shall be large enough to contain sufficient DME for duplicate analyses in the event that the first analysis is unreliable. Typical sample cylinders are shown in [Figure 2](#).

A floating-piston-type sample cylinder may be used as an alternative (see [Figure 3](#)).

7 Sampling

7.1 Terminal in a loading port

7.1.1 Loading from a single shore tank.

Carry out sampling when the DME is being loaded at full rate. The sample thus obtained is considered as representative of the whole consignment.

7.1.2 Loading from multiple shore tanks.

Carry out sampling for each shore tank while DME is being loaded at full rate. The samples thus obtained are considered as representative of each shore tank.

7.2 Terminal in an unloading port

7.2.1 Unloading from a single cargo tank.

Carry out sampling when the DME is being unloaded at full rate.

7.2.2 Unloading from multiple cargo tanks.

In general, all the cargo pumps of the cargo tanks from which DME is being unloaded are operated simultaneously. Irrespective of the number of cargo tanks, carry out sampling when DME is being unloaded at full rate from all of the scheduled cargo tanks.

8 Preparation for sampling

8.1 Visual inspection of sampling line and sample cylinder

Prior to connection of the sample line, which has previously been coupled with a sample cylinder, at one end to a sample probe mounted on the pipe line for receiving/delivering DME, visually inspect and confirm that the sampling line and sample cylinder have no apparent damage.

8.2 Connection of the apparatus

Connect the apparatus as shown in [Figure 1](#).

8.3 Purging the sampling line and sample cylinder

Prior to use, the inside of the sampling line and the sample cylinder shall be cleaned. Cleaning shall be performed by purging any residue that remains in the sampling line or sample cylinder.

Purging operation can be implemented by repeated filling/discharging of DME. Purging may be halted when liquid instead of vapour appears from the sample cylinder. Fully close both inlet and outlet valves following the completion of flushing.

It is recommended that the sampling line and sample cylinder be used exclusively for DME to minimize repetition of the purging operation. Steam cleaning is recommended if the sample cylinder was previously used for other product.

If new sample cylinders are used, clean the inside with appropriate solvents before use.

9 Sampling procedure

9.1 General

Sampling is carried out by filling a sample cylinder with pressurized DME that is flowing in the line. The temperature of the DME at this time is approximately $-25\text{ }^{\circ}\text{C}$ and the pressure exceeds ambient pressure. However, this assumption varies with various factors at the time of sampling.

When the sample volume is small or when the ambient temperature is high, use of a floating-piston-type sample cylinder is effective to confirm that only the liquid is being taken for the sample.

9.2 Two-valve sample cylinder with or without ullage tube

The sampling procedure using a two-valve sample cylinder with or without ullage tube is as follows.

- a) Fill the sample cylinder with DME by opening the control valve of the sampling line and inlet valve of the sample cylinder.
- b) Close the control valve of the sampling line and inlet valve of the sample cylinder when the sample cylinder is filled with DME.
- c) The decision as to whether or not the sample cylinder is filled with DME depends on the time elapsed, a measurement of the mass of the cylinder or other appropriate means.
- d) Open the exhaust valve of the sampling line and release the pressure therein.
- e) Disconnect the sampling line from the control valve.
- f) Disconnect the sample cylinder from the sampling line.

9.3 Single-valve sample cylinder

In the case that a single-valve sample cylinder is used, apply the same procedure as for the two-valve sample cylinder.

9.4 Two-valve sample cylinder with a siphon tube

The sampling procedure using a two-valve sample cylinder with a siphon tube is as follows.

- a) Close the inlet valve (with a siphon tube) and outlet valve (without a siphon tube).
- b) Fill the sample cylinder with DME by opening the control valve of the sampling line and inlet valve of the sample cylinder. If necessary, open the outlet valve (without a siphon tube) of the sample cylinder and release the pressure therein.
- c) Close the control valve of the sampling line and inlet valve of the sample cylinder when the sample cylinder is filled with DME.
- d) The decision as to whether or not the sample cylinder is filled with DME depends on the time elapsed, a measurement of the mass of the cylinder or other appropriate means.

- e) Open the exhaust valve of the sampling line and release the pressure therein.
- f) Disconnect the sampling line from the sample probe on the DME receiving/delivery line.
- g) Disconnect the sample cylinder from the sampling line.

10 Adjustment of sample volume

10.1 Two-valve sample cylinder without ullage tube

The amount of sample in the sample cylinder shall be adjusted in accordance with the procedure described in a) through f).

- a) Weigh the sample cylinder prior to sampling and record the mass.
- b) Multiply the density of the liquid DME by the capacity of the sample cylinder, and calculate the net mass of DME when the sample cylinder is completely filled. The amount of sample that is collected in the sample cylinder shall be 85 % of the net mass thus calculated.
- c) Add the mass of the DME sample that is obtained to the mass of the sample cylinder obtained in a). The result is the gross mass of the sample cylinder 85 % filled with DME.
- d) Start sampling. Determine the completion of sampling on the basis of time spent for sampling or by other appropriate means.
- e) Weigh the mass of the sample cylinder filled with DME and then compare it with predefined gross mass of the sample cylinder filled with 85 % of DME as obtained in c).
- f) If the gross mass of the sample cylinder exceeds the pre-calculated value, hold the sample cylinder upright then release DME little by little from the valve located at the lower position, weighing the sample cylinder repeatedly until it becomes nearly equal to the value determined in c).

10.2 Two-valve sample cylinder with ullage tube

The adjustment procedure using a two-valve sample cylinder with ullage tube is as follows.

- a) Stand the sample cylinder upright keeping the end equipped with the ullage tube (outlet valve) up.
- b) Open the outlet valve slightly.
- c) Allow the excess liquid to escape.
- d) Close the valve at the first sign of vapour.
- e) If no liquid escapes, discard the sample and refill the sample cylinder.

NOTE An alternative method is the use of an automatic sampler, which can be safer and more effective.

10.3 Single-valve sample cylinder

The procedure in [10.1](#) is also applicable to a single-valve sample cylinder. In this case, step f) shall be carried out holding the sample cylinder upside down.

10.4 Two-valve sample cylinder with a siphon tube

The amount of sample in the sample cylinder shall be adjusted in accordance with the procedure described in a) through f).

- a) Weigh the sample cylinder prior to sampling and record the mass.

- b) Multiply the density of the liquid DME by the capacity of the sample cylinder, and calculate the net mass of DME when the sample cylinder is completely filled. The amount of sample that is collected in the sample cylinder shall be 85 % of the net mass thus calculated.
- c) Add the mass of the DME sample that is obtained to the mass of the sample cylinder obtained in a). The result is the gross mass of the sample cylinder 85 % filled with DME.
- d) Start sampling. Determine the completion of sampling on the basis of time spent for sampling or by other appropriate means.
- e) Weigh the mass of the sample cylinder filled with DME and then compare it with predefined gross mass of the sample cylinder filled with 85 % of DME as obtained in c).
- f) If the gross mass of the sample cylinder exceeds the pre-calculated value, release DME little by little from the inlet valve (with a siphon tube), weighing the sample cylinder repeatedly until it becomes nearly equal to the value determined in c).

11 Checking for leakage

If clear evidence of leakage from the sample cylinder is found, the sample shall be discarded. The leaking cylinder shall not be used until it has been repaired.

NOTE Confirmation of leakage from the sample cylinder by placing it in a water bath is not recommended because if DME does leak from the sample cylinder, it forms condensation due to the heat of vaporization at ambient temperature. Furthermore, if the cylinder is placed in a water bath, leakage cannot be confirmed unless it is very large, due to the solubility of the DME bubbles in the water.

12 Number of samples

Obtain two samples successively in separate sample cylinders. One is for immediate analysis and the other is retained.

The period of time to keep the retained sample is decided on the basis of discussions among the parties concerned.

13 Identification of sample cylinder

A label noting the following items shall be attached on the sample cylinder:

- a) all details necessary for complete identification of the sample:
 - name of contents (DME);
 - date and time of sampling;
 - identity of person taking sample;
 - number of the sample cylinder and the sample;
 - place at which the sample was taken;
 - name of the ship and tank number(s), if applicable;
 - shore tank number(s), if applicable;
- b) any unusual features or event that occurred during sampling;
- c) information regarded as optional and those not included in this document;
- d) any deviation, by agreement or otherwise, from the procedure specified.

14 Retention of samples

It is recommended to carry out analysis of the sample as soon as possible after sampling. Attention shall be paid to the following if the samples are temporarily stored prior to analysis, or for the storage of archive samples:

- a) keep the sample in a dry and suitably ventilated room;
- b) the sample shall be kept away from flammable and combustible materials;
- c) avoid sources of heat or direct sunshine;
- d) all electrical equipment in the storage room shall be of the explosion-proof type.

Bibliography

- [1] ISO 4257, *Liquefied petroleum gases — Method of sampling*

British Standards Institution (BSI)

BSI is the national body responsible for preparing British Standards and other standards-related publications, information and services.

BSI is incorporated by Royal Charter. British Standards and other standardization products are published by BSI Standards Limited.

About us

We bring together business, industry, government, consumers, innovators and others to shape their combined experience and expertise into standards-based solutions.

The knowledge embodied in our standards has been carefully assembled in a dependable format and refined through our open consultation process. Organizations of all sizes and across all sectors choose standards to help them achieve their goals.

Information on standards

We can provide you with the knowledge that your organization needs to succeed. Find out more about British Standards by visiting our website at bsigroup.com/standards or contacting our Customer Services team or Knowledge Centre.

Buying standards

You can buy and download PDF versions of BSI publications, including British and adopted European and international standards, through our website at bsigroup.com/shop, where hard copies can also be purchased.

If you need international and foreign standards from other Standards Development Organizations, hard copies can be ordered from our Customer Services team.

Copyright in BSI publications

All the content in BSI publications, including British Standards, is the property of and copyrighted by BSI or some person or entity that owns copyright in the information used (such as the international standardization bodies) and has formally licensed such information to BSI for commercial publication and use.

Save for the provisions below, you may not transfer, share or disseminate any portion of the standard to any other person. You may not adapt, distribute, commercially exploit, or publicly display the standard or any portion thereof in any manner whatsoever without BSI's prior written consent.

Storing and using standards

Standards purchased in soft copy format:

- A British Standard purchased in soft copy format is licensed to a sole named user for personal or internal company use only.
- The standard may be stored on more than 1 device provided that it is accessible by the sole named user only and that only 1 copy is accessed at any one time.
- A single paper copy may be printed for personal or internal company use only.

Standards purchased in hard copy format:

- A British Standard purchased in hard copy format is for personal or internal company use only.
- It may not be further reproduced – in any format – to create an additional copy. This includes scanning of the document.

If you need more than 1 copy of the document, or if you wish to share the document on an internal network, you can save money by choosing a subscription product (see 'Subscriptions').

Reproducing extracts

For permission to reproduce content from BSI publications contact the BSI Copyright & Licensing team.

Subscriptions

Our range of subscription services are designed to make using standards easier for you. For further information on our subscription products go to bsigroup.com/subscriptions.

With **British Standards Online (BSOL)** you'll have instant access to over 55,000 British and adopted European and international standards from your desktop. It's available 24/7 and is refreshed daily so you'll always be up to date.

You can keep in touch with standards developments and receive substantial discounts on the purchase price of standards, both in single copy and subscription format, by becoming a **BSI Subscribing Member**.

PLUS is an updating service exclusive to BSI Subscribing Members. You will automatically receive the latest hard copy of your standards when they're revised or replaced.

To find out more about becoming a BSI Subscribing Member and the benefits of membership, please visit bsigroup.com/shop.

With a **Multi-User Network Licence (MUNL)** you are able to host standards publications on your intranet. Licences can cover as few or as many users as you wish. With updates supplied as soon as they're available, you can be sure your documentation is current. For further information, email subscriptions@bsigroup.com.

Revisions

Our British Standards and other publications are updated by amendment or revision.

We continually improve the quality of our products and services to benefit your business. If you find an inaccuracy or ambiguity within a British Standard or other BSI publication please inform the Knowledge Centre.

Useful Contacts

Customer Services

Tel: +44 345 086 9001

Email (orders): orders@bsigroup.com

Email (enquiries): cservices@bsigroup.com

Subscriptions

Tel: +44 345 086 9001

Email: subscriptions@bsigroup.com

Knowledge Centre

Tel: +44 20 8996 7004

Email: knowledgecentre@bsigroup.com

Copyright & Licensing

Tel: +44 20 8996 7070

Email: copyright@bsigroup.com

BSI Group Headquarters

389 Chiswick High Road London W4 4AL UK