

BS ISO 29584:2015



BSI Standards Publication

Glass in building — Pendulum impact testing and classification of safety glass

bsi.

...making excellence a habit.™

National foreword

This British Standard is the UK implementation of ISO 29584:2015.

The UK participation in its preparation was entrusted to Technical Committee B/520/4, Properties and glazing methods.

A list of organizations represented on this committee can be obtained on request to its secretary.

This publication does not purport to include all the necessary provisions of a contract. Users are responsible for its correct application.

© The British Standards Institution 2016.
Published by BSI Standards Limited 2016

ISBN 978 0 580 85092 9

ICS 81.040.20

Compliance with a British Standard cannot confer immunity from legal obligations.

This British Standard was published under the authority of the Standards Policy and Strategy Committee on 31 January 2016.

Amendments/corrigenda issued since publication

Date	Text affected
------	---------------

INTERNATIONAL
STANDARD

ISO
29584

First edition
2015-12-01

**Glass in building — Pendulum impact
testing and classification of safety glass**

*Verre dans la construction — Essai d'impact au pendule et
classification du verre de sécurité*



Reference number
ISO 29584:2015(E)

© ISO 2015



COPYRIGHT PROTECTED DOCUMENT

© ISO 2015, Published in Switzerland

All rights reserved. Unless otherwise specified, no part of this publication may be reproduced or utilized otherwise in any form or by any means, electronic or mechanical, including photocopying, or posting on the internet or an intranet, without prior written permission. Permission can be requested from either ISO at the address below or ISO's member body in the country of the requester.

ISO copyright office
Ch. de Blandonnet 8 • CP 401
CH-1214 Vernier, Geneva, Switzerland
Tel. +41 22 749 01 11
Fax +41 22 749 09 47
copyright@iso.org
www.iso.org

Contents

Page

Foreword	iv
Introduction	v
1 Scope	1
2 Normative references	1
3 Terms and definitions	2
4 Test requirements	2
5 Test method	3
5.1 Test apparatus	3
5.2 Calibration of test apparatus.....	12
5.3 Test pieces.....	12
5.3.1 General.....	12
5.3.2 Dimensions of the test pieces	12
5.3.3 Number of test pieces.....	12
5.3.4 Preparation of the test pieces.....	12
5.4 Impact test procedure.....	12
6 Classification	13
6.1 General.....	13
6.2 Drop height class.....	14
6.3 Mode of breakage.....	14
6.4 Performance classification.....	14
7 Test report	15
Annex A (normative) Method of fabrication of the shot bag impactor	17
Annex B (normative) Calibration of the test rig	23
Annex C (normative) Sphere penetration test	29
Annex D (informative) Example of a test rig	30
Annex E (informative) Terms and definitions of glass types	33
Annex F (informative) Example of release mechanism	35
Bibliography	40

Foreword

ISO (the International Organization for Standardization) is a worldwide federation of national standards bodies (ISO member bodies). The work of preparing International Standards is normally carried out through ISO technical committees. Each member body interested in a subject for which a technical committee has been established has the right to be represented on that committee. International organizations, governmental and non-governmental, in liaison with ISO, also take part in the work. ISO collaborates closely with the International Electrotechnical Commission (IEC) on all matters of electrotechnical standardization.

The procedures used to develop this document and those intended for its further maintenance are described in the ISO/IEC Directives, Part 1. In particular the different approval criteria needed for the different types of ISO documents should be noted. This document was drafted in accordance with the editorial rules of the ISO/IEC Directives, Part 2 (see www.iso.org/directives).

Attention is drawn to the possibility that some of the elements of this document may be the subject of patent rights. ISO shall not be held responsible for identifying any or all such patent rights. Details of any patent rights identified during the development of the document will be in the Introduction and/or on the ISO list of patent declarations received (see www.iso.org/patents).

Any trade name used in this document is information given for the convenience of users and does not constitute an endorsement.

For an explanation on the meaning of ISO specific terms and expressions related to conformity assessment, as well as information about ISO's adherence to the WTO principles in the Technical Barriers to Trade (TBT) see the following URL: [Foreword - Supplementary information](#)

The committee responsible for this document is ISO/TC 160, *Glass in building*, Subcommittee SC 2, *Use considerations*.

This first edition cancels and replaces ISO/TS 29584:2012, which has been technically revised.

Introduction

Accidental human impact with glass panes can be a source of injury. The classification of glass in terms of its ability to withstand impact and the consequences of the glass breaking under such impact has been considered in many countries. The use of a soft body impactor to represent a human body has enabled regulators, code officials and other control organizations to specify glazing that reduces the risk of cutting and piercing injuries.

This International Standard has been prepared as a means of detailing the differences and similarities in pendulum impact tests for the classification of safety glass.

The traditional impactor has been a lead shot-filled leather bag. This has been found to suffer from ageing or shape change and variability in the energy transfer into the test piece if not properly maintained. It has been found that there can be wide variation in the supporting frame or sub-frame.

During their work, CEN /TC 129/WG 13 examined some of the problems associated with the lead shot-filled leather bag impactor and the supporting frame. CEN/TC 129/WG 13 prepared EN 12600 that uses an impactor consisting of steel masses and two tyres.

The primary objectives in developing the new impactor for the evaluation of safety glass can be summarized as follows:

- a) elimination of the differences between
 - 1) taped and un-taped lead shot bags and
 - 2) lead shot bags and bags filled with sand or glass beads;
- b) ageing of lead shot bag;
- c) elimination of the use of lead shot;
- d) harmonization of national impact test methods.

Glass in building — Pendulum impact testing and classification of safety glass

1 Scope

The purpose of this International Standard is to evaluate, by means of soft body impactors, safe breakage characteristics of glazing products intended to reduce cutting and piercing injuries to persons through accidental impact.

This International Standard examines test methods currently employed to determine the pendulum impact performance of safety glass. Use of the methodologies in this International Standard improves the reproducibility of test results and gives a common basis of classification. The aim is for the performance of glass products manufactured and tested in various countries to be better understood and more consistent.

Two types of soft body impactors are defined. The traditional shot bag impactor is detailed both in terms of manufacture and maintenance in an attempt to overcome problems associated with such impactors becoming misshapen. The twin tyre impactor is also detailed.

The test equipment, excluding the impactor, is also described. A method of calibrating the test frame is given. The benefit of calibrating the test equipment is the increased reproducibility of the test results.

Classification of glass products is also detailed. The classification system allows information on the following to be given:

- a) the maximum drop height at which the glass either did not break or broke safely, i.e. in a manner similar to laminated glass or toughened glass;
- b) the manner in which the glass would break, i.e. as toughened glass, laminated glass, annealed glass, irrespective of whether or not the glass was broken during the test;
- c) the maximum drop height at which the glass either did not break or broke safely, i.e. in a manner similar to laminated glass.

This International Standard does not specify the intended use of the products, but provides a method of classification in terms of the performance of the materials being tested. The impact energy used for the various levels of classification are designed to provide the intended user or the legislator with the information to assist in defining the level of safety and protection required relative to the intended location at which the selected safety glass is to be used.

2 Normative references

The following documents, in whole or in part, are normatively referenced in this document and are indispensable for its application. For dated references, only the edition cited applies. For undated references, the latest edition of the referenced document (including any amendments) applies.

ISO 48, *Rubber, vulcanized or thermoplastic — Determination of hardness (hardness between 10 IRHD and 100 IRHD)*

ISO 2408, *Steel wire ropes for general purposes — Minimum requirements*

ISO 4251-1, *Tyres (ply rating marked series) and rims for agricultural tractors and machines — Part 1: Tyre designation and dimensions, and approved rim contours*

3 Terms and definitions

For the purposes of this document, the following terms and definitions apply.

3.1 safety glass

glazing material so treated, constructed or combined with other materials that, if fractured or broken by accidental human contact, gives fragments which are less likely to pierce or to cause severe cuts than fragments of ordinary annealed glass, or the likelihood of cutting and piercing injuries that might result from such contact is minimized by glass shard containment

EXAMPLE Laminated glasses and thermally toughened glasses are types of safety glazing material.

3.2 soft body impactor

impactor that is representative of a human body

EXAMPLE A soft body impactor can be either a shot bag (see [5.1.3.1](#)) or a twin tyre (see [5.1.3.2](#)) type.

3.3 asymmetric material

glass that has different surface characteristics on opposite faces, e.g. patterning, coating, or manufactured from laminations of glass or plastics glazing sheet material together with interlayer materials that are arranged in different sequential order and of varying thicknesses

3.4 drop height

vertical height from the horizontal centre line of the impactor at the point of release to the horizontal centre line of the impactor when at rest vertically

3.5 crack-free particle

piece of glass that does not contain any cracks that run from one edge to another

Note 1 to entry: See [Figure 1](#).

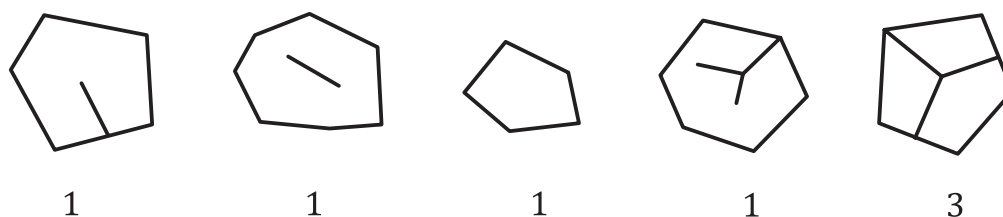

Key

1, 3 numbers of crack free particles in each piece of glass

Figure 1 — Example of crack free particles

3.6 masking

temporary protective covering applied to the test piece for ease of transportation

4 Test requirements

4.1 When tested by the method given in [Clause 5](#), each test piece shall either not break or shall break as defined in one of [4.2](#) and [4.3](#).

4.2 Numerous cracks appear, but no shear or opening is allowed within the test piece through which a (76 ± 1) mm diameter sphere can pass when a maximum force of 25 N is applied (in accordance with [Annex C](#)).

Additionally, if particles are detached from the test piece up to 3 min after impact, they shall, in total, weigh no more than the mass equivalent to 10 000 mm² of the original test piece. The largest single particle shall weigh no more than the mass equivalent of 4 400 mm² of the original test piece. Within 5 min of impact and disintegration occurs the 10 largest crack-free particles collected shall weigh no more than the mass equivalent to 6 500 mm² of the original test piece. The particles shall be selected only from the portion of the original test piece exposed in the test frame. Only the exposed area of any particle retained in the test frame shall be taken into account in determining the mass equivalent.

4.3 The 10 largest crack-free particles collected within 3 min after impact shall weigh no more than the mass equivalent of 6 500 mm² of the original test piece.

5 Test method

5.1 Test apparatus

5.1.1 Main frame, constructed from welded or bolted, hot-rolled steel channel sections with rounded edges, designed to present a rigid and flat surface to the sub-frame. See [Figures 2](#) and [3](#). The lower cross members shall be securely fixed to a concrete floor.

NOTE Additional support to the frame can be provided, if required, by means of horizontal steel sections fixed to an adjacent rigid wall (see [Figure 2](#), key 4).

The dimensions of the main frame (see [Figure 4](#)) shall be as follows:

- a) internal width: (847 ± 5) mm;
- b) internal height: $(1\,910 \pm 5)$ mm.

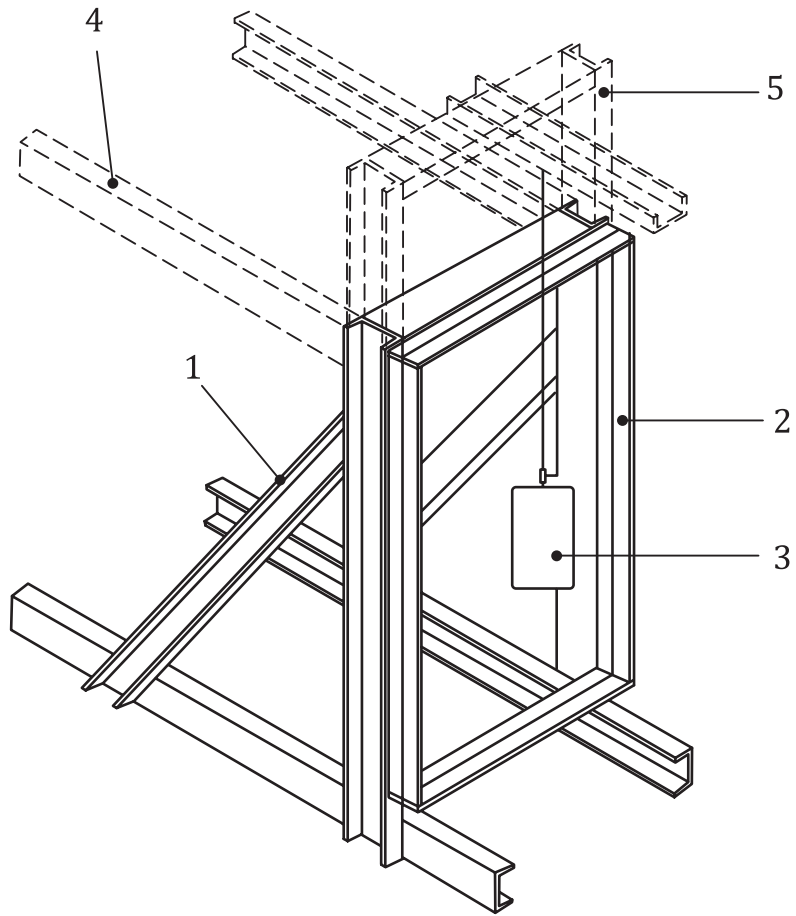

Key

- 1 main frame
- 2 clamping frame
- 3 impactor
- 4 optional support member
- 5 optional suspension device

Figure 2 — Test frame

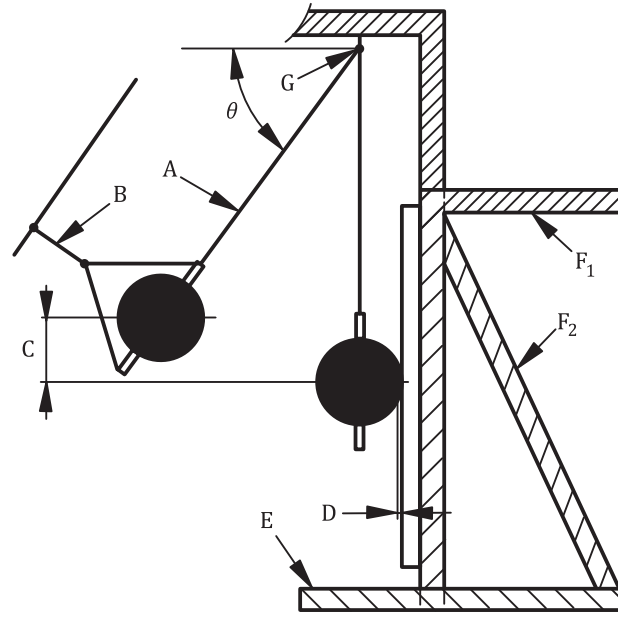

Key

- A suspension cable
- B traction cable
- C drop height
- D impactor distance from sample
- E support member
- F₁ optional support member
- F₂ cross members
- G bracket ($5 \text{ mm} \leq d \leq 15 \text{ mm}$)
- θ impactor angle from horizontal

Figure 3 — Side elevation of the main frame with the impactor

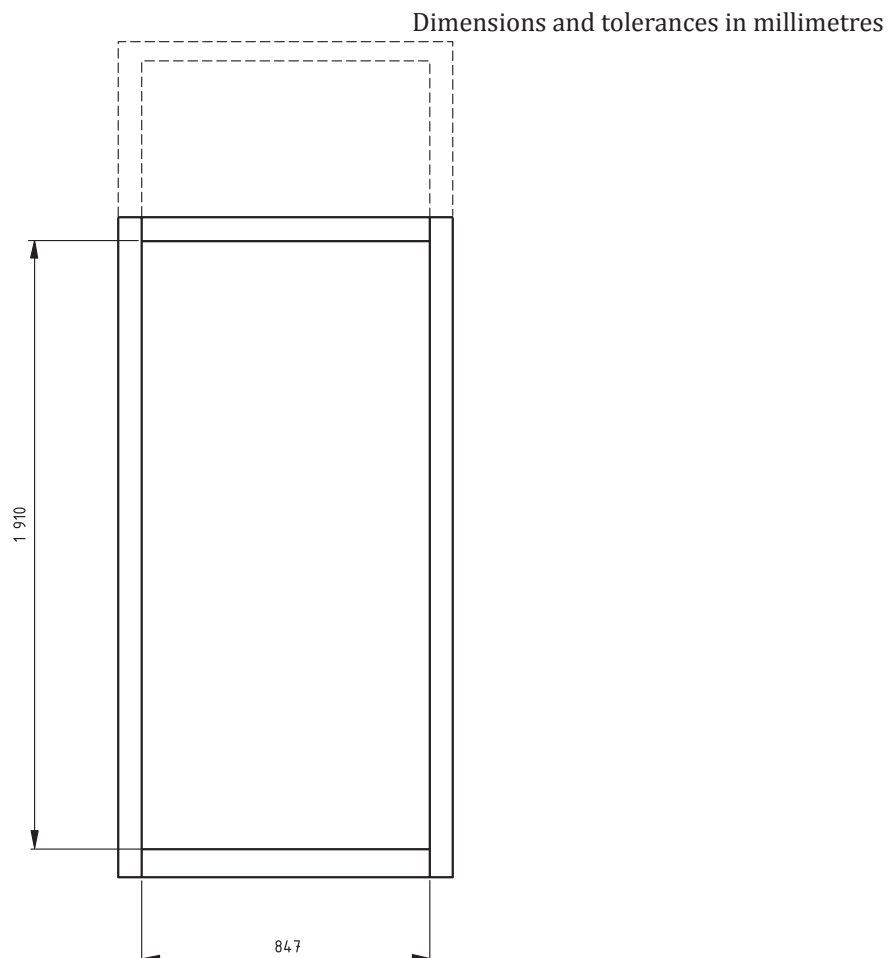

Figure 4 — Dimensions of the front elevation of the frame

5.1.2 Clamping frame, fitted on to the main frame and used to hold the test piece in position for the duration of the test, consisting of two rectangular parts which clamp the test piece along its perimeter. See [Figure 5](#). The inner part of the clamping frame is attached to the main frame.

The assembly is held together by a clamping device. The clamping frame shall be suitably rigid to withstand the pressure exerted by the clamping device.

The dimensions of the clamping frame shall be as follows:

- a) internal width: (847 ± 5) mm;
- b) internal height: $(1\,910 \pm 5)$ mm.

Each part of the clamping frame shall be fitted with a strip of rubber. The rubber strips shall be the only element in contact with the test piece and shall be (20 ± 2) mm wide and (10 ± 1) mm thick and have a hardness of (60 ± 5) IRHD in accordance with ISO 48.

NOTE Polychloroprene (polychloroprene) or a similar material is suitable.

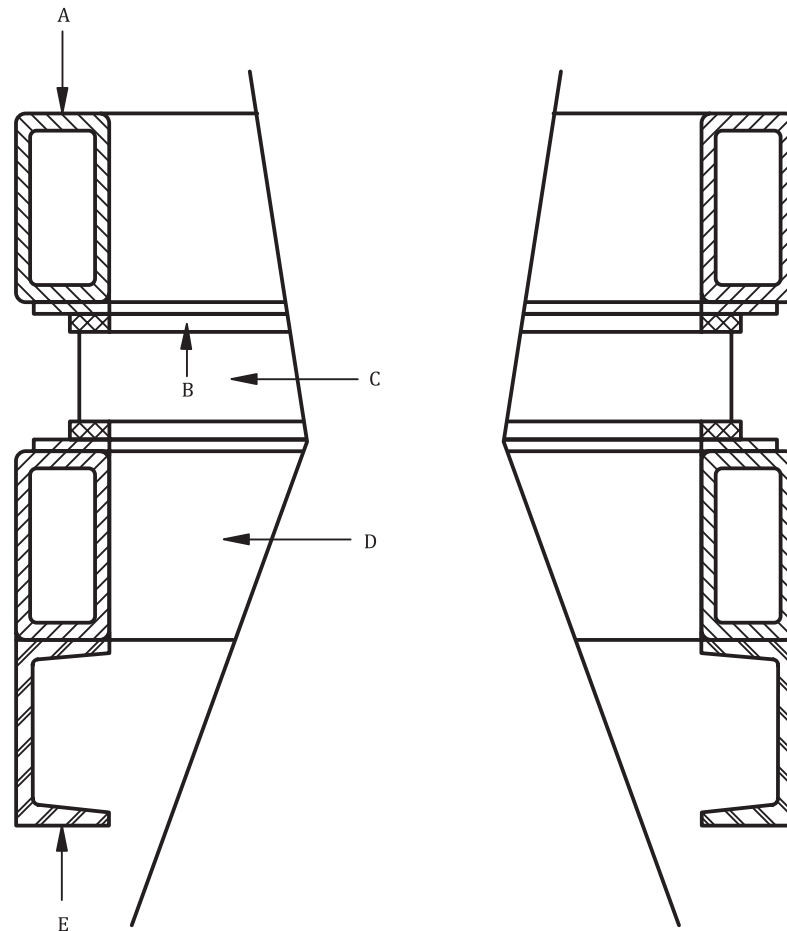

Key

- A clamping frame, e.g. $\sim 100 \text{ mm} \times 50 \text{ mm} \times 8 \text{ mm}$
- B rubber strips $(20 \pm 2) \text{ mm} \times (10 \pm 1) \text{ mm}$
- C test piece
- D outer part of the main frame, e.g. $\sim 100 \text{ mm} \times 50 \text{ mm} \times 8 \text{ mm}$
- E inner part of the main frame, e.g. $\leq 100 \text{ mm} \times 50 \text{ mm}$

Figure 5 — Example of clamping of the test piece

5.1.3 Impactor, of type [5.1.3.1](#) or [5.1.3.2](#), suitable for use with the suspension device ([5.1.4](#)) and release mechanism ([5.1.5](#)).

5.1.3.1 Lead shot bag.

5.1.3.1.1 General description.

The bag (see [Figure 6](#)) is a reinforced leather bag filled with chilled lead shot of diameter $(2,5 \pm 0,1) \text{ mm}$ providing a total mass of $(45 \pm 0,1) \text{ kg}$. The bag is constructed of $1,5 \text{ mm}$ thick pliable leather (see [Figure 7](#)).

5.1.3.1.2 Method of manufacture.

See [Annex A](#).

5.1.3.1.3 Maintenance. Inspect the shot bag impactor at intervals of 1 000 impacts and calibrate as required. If the tape of the impactor is damaged (e.g. when glass fibres are apparent, or the leather bag

is visible), it shall be removed and replaced according to [Annex A](#). When the deformation of the impactor is beyond the tolerances, the impactor shall be reshaped manually. If the impactor cannot be restored to within the tolerances, it shall be replaced.

Remove all glass particles embedded in the surface of the impactor.

The tolerances of dimensions for the impactor are shown in [Figure 6](#).

Dimensions and tolerances in millimetres

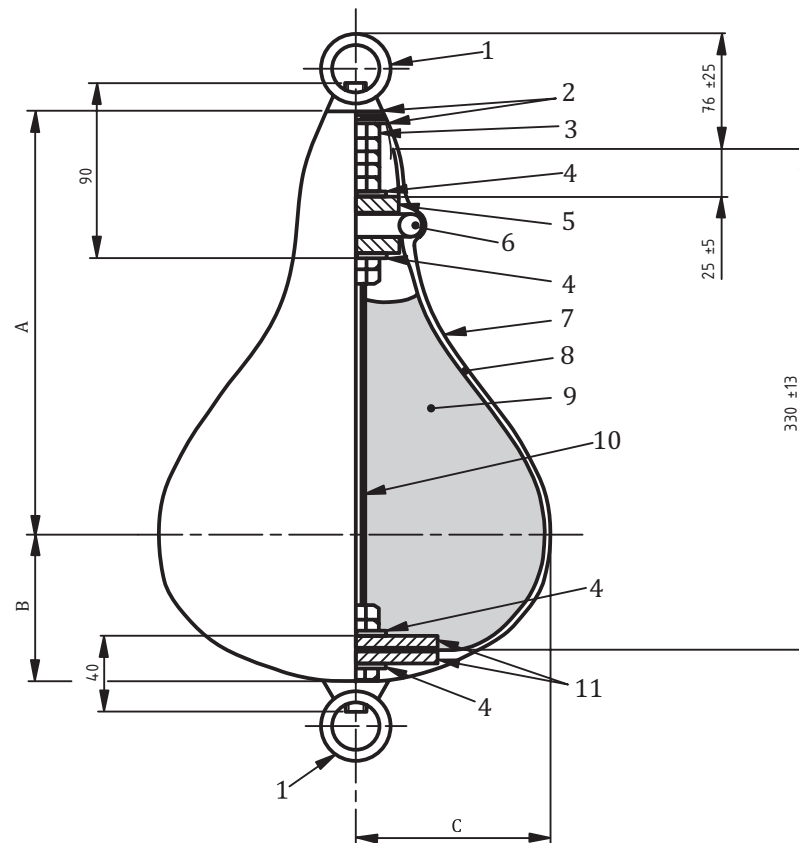

Key

	No. required	Remarks
1 eye nut	2 M10	
2 plane washer	2 M10	
3 hexagonal nut	10 M10	
4 spring washer	4 M10	
5 sleeve nut	1 length: 25 mm; diameter: 32 mm	
6 hose clamp	1	
7 glass fibre-reinforced adhesive polyester tape (see Note 2)	3 rolls width: 12 mm; thickness: 0,15 mm	
8 leather bag	1 synthetic leather (see Note 1)	
9 lead shot	~45 kg chilled shot, diameter: (2,5 ± 0,1) mm	
10 threaded metal rod	1 M10 Length: 400 mm	
11 metal washer	2 thickness: (4,8 ± 1,6) mm; diameter: (76 ± 3) mm	

NOTE 1 The bag is made of the synthetic leather of thickness 1,5 mm by seaming up with two sheets of piece A (see [Figure 7](#)) and four sheets of piece B (see [Figure 7](#)). The margin to seam between pieces A and B is about 4 mm. The Model SB-4500¹⁾ is the trade name of a product supplied by Wining KK.

NOTE 2 3 M N° 898 is the trade name of a product supplied by 3M Company.²⁾

Figure 6 — Plan of shot bag impactor

1) This information is given for the convenience of users of this document and does not constitute an endorsement by ISO of the product named. Equivalent products may be used if they can be shown to lead to the same results.

2) This information is given for the convenience of users of this document and does not constitute an endorsement by ISO of the product named. Equivalent products may be used if they can be shown to lead to the same results.

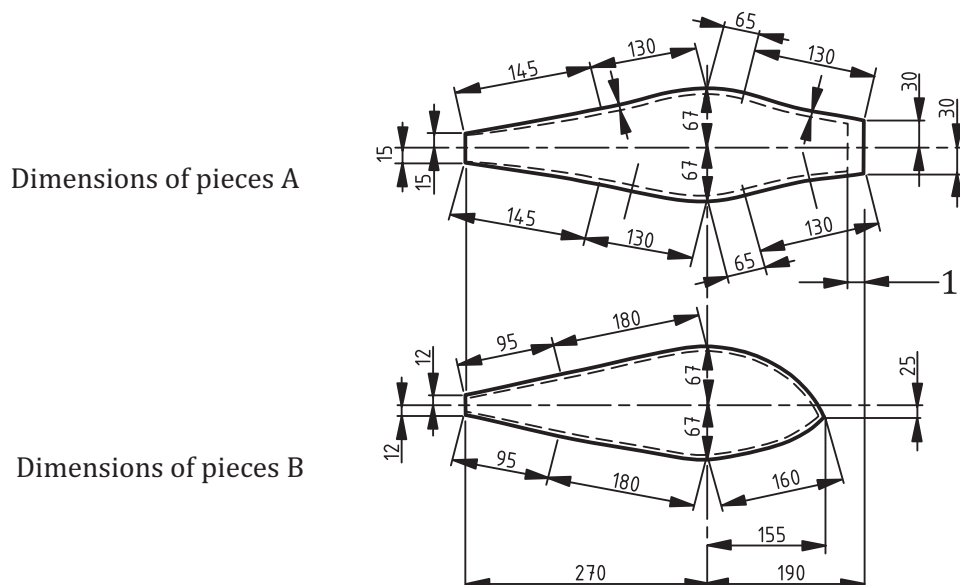

Key
 1 margin to seam 16 mm

Figure 7 — Dimensions of pieces of shot bag impactor

5.1.3.2 Twin tyre impactor.

5.1.3.2.1 General description

Impactor consisting of two pneumatic tyres, e.g. tyre 3.50-8/4PR³⁾ or Continental T7³⁾, in accordance with ISO 4251-1, with round section and flat longitudinal tread. See [Figure 8](#). The tyres shall be fitted to the rims of the wheels that carry two equal steel masses. The masses shall be dimensioned so that the total mass of the impactor is $(50 \pm 0,1)$ kg.

NOTE The tyre specified for this impactor, while in accordance with ISO 4251-1, has been found to have performance variations dependent on site and country of manufacture. This variation can cause problems with the calibration, but has not been found to affect product classification.

5.1.3.2.2 Method of manufacture

An example of the impactor, using steel with a density of $7\,830\text{ kg/m}^3$, is shown in [Figure 8](#).

5.1.3.2.3 Maintenance

Check the air pressure in the tyres in accordance with [5.4.3](#).

Remove all glass particles embedded in the surface of the tyres.

Inspect the state of the tyres regularly and replace when required.

³⁾ Tyre 3.50-8/4PR (reference V47, V60, and V64) and Continental T7 are examples of suitable products available commercially. This information is given for the convenience of users of this document and does not constitute an endorsement by ISO of these products.

Dimensions in millimetres

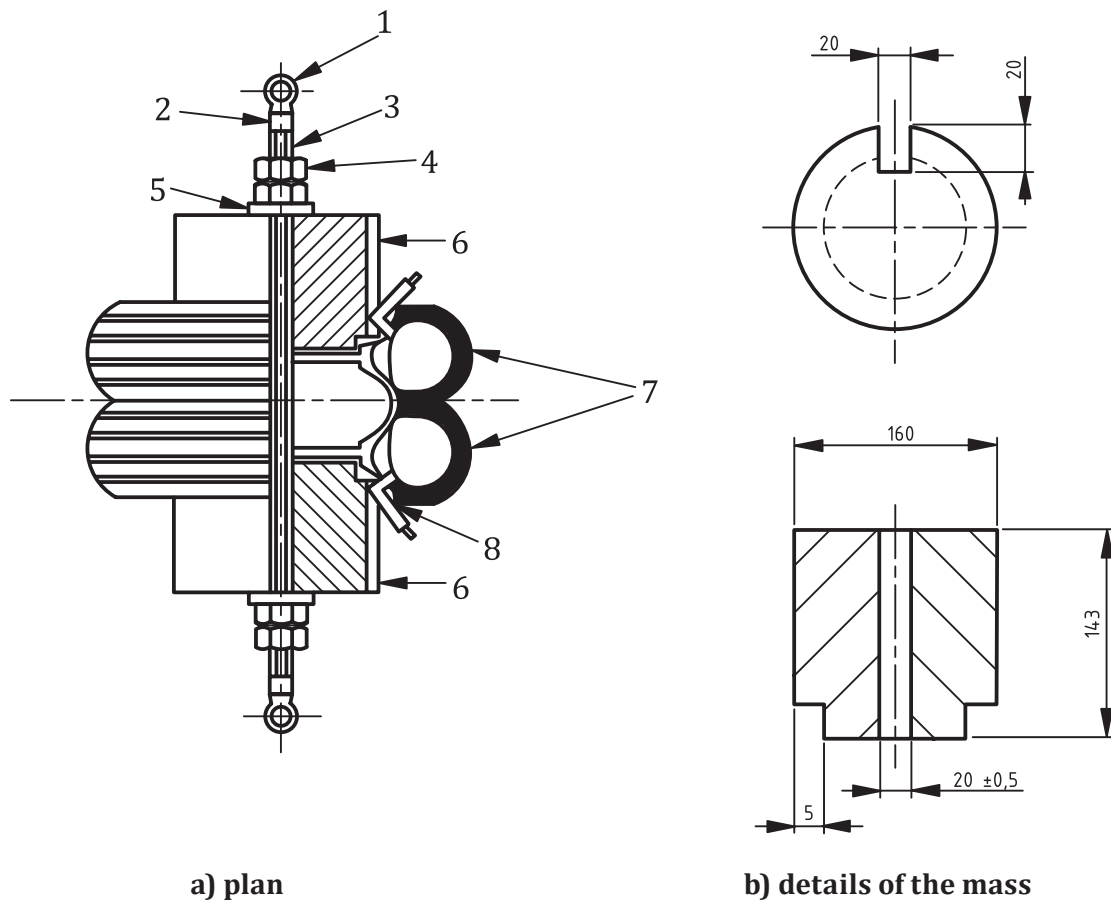

Key

	No. required	Remarks
1 eye bolt	2	M20
2 hexagonal nut	2	M20
3 screw spindle	1	M20 45 mm
4 hexagonal nut	4	M20
5 collar	4	
6 mass of density 7 830 kg/m ³	2	See Figure 8 b)
7 pneumatic tyre	2	Tyre 3.50-8/4PR ²)
8 rim	2	250 – 8

Figure 8 — The twin tyre impactor

5.1.4 Suspension device.

The impactor shall be suspended by means of a steel cable of diameter 5 mm conforming to ISO 2408, from a bracket attached above the head of the main frame. The bracket shall be rigid to ensure that the point of suspension remains stationary during the test and shall be positioned to permit the impactor to strike the centre of the test piece.

At the highest drop height, the angle, θ , between the taut suspension cable and the bracket shall not be less than 14° (see [Figure 3](#)).

When the impactor is hanging freely, at rest, the distance between the impactor and the surface of the test piece, d , shall not exceed 15 mm and shall not be less than 5 mm (see [Figure 3](#)) and the centre of area of contact of the impactor shall be within 50 mm vertically and horizontally from the centre of the test piece.

5.1.5 Traction and release system.

The impactor release mechanism enables the impactor to be raised and positioned at each of the specified drop height positions, and then to be released so that it swings freely and impacts the test piece. The release cable shall be connected to the top and bottom ends of the impactor by suitable links so that the raising force is applied at right angles to the axis of the impactor. The release mechanism shall ensure that the release cable is maintained at the correct orientation at each of the drop heights. An example of a release mechanism is given in [Annex F](#).

5.2 Calibration of test apparatus

The test apparatus shall be calibrated in accordance with [Annex B](#), in order to ensure that the energy transferred to the test piece by the impactor during the test carried out on different apparatus is consistent.

5.3 Test pieces

5.3.1 General

Each test piece shall comprise a single pane of glass product and be representative of the normal production of the type of product submitted for test.

5.3.2 Dimensions of the test pieces

The test pieces shall have the following dimensions:

- a) width: (876 ± 2) mm;
- b) height: $(1\ 938 \pm 2)$ mm.

Results obtained with test pieces of these dimensions are valid for classification purposes of the glass product whatever the service dimensions.

5.3.3 Number of test pieces

The test shall be carried out at each drop height on four pieces of identical structure and the same nominal thickness.

If the test pieces are of an asymmetric material, their number shall be doubled unless they are intended solely for installation in situations where the risk of impact is from one side only.

5.3.4 Preparation of the test pieces

Remove all masking and protection material from the test pieces and condition for a minimum of 12 h at (20 ± 5) °C.

5.4 Impact test procedure

5.4.1 Testing shall start at the lowest drop height (see [Table 1](#)) and increase up to the drop height appropriate to the class for which the material is intended (see [6.2](#)).

5.4.2 The test shall be carried out at (20 ± 5) °C, i.e. room temperature.

5.4.3 Place each test piece in the clamping frame so that its edges are encased in the rubber to a minimum depth of 10 mm. The test piece shall be firmly clamped within the sub-frame.

Use either a twin tyre impactor or shot bag impactor. When using the twin tyre impactor, inflate both impactor tyres to a pressure of $(0,35 \pm 0,02)$ MPa. Pressure shall be checked prior to testing and every 4 h after the start of the test.

Raise the impactor to the lowest drop height (see [Table 1](#)) and stabilize. At the drop height, the suspension cable shall be taut, and the axis of the impactor and cable shall be in line (see [Figure 3](#)).

Table 1 — Impact levels

Classification	Lead shot bag mm	Twin tyre mm
3	300	190
2	450	450
1	1 200	1 200

5.4.4 Release the impactor so that it falls with a pendular movement and without initial velocity. The direction of impact on the centre of the test piece shall be normal to the surface. If the impactor strikes the test piece more than once the test shall be deemed to be invalid.

Use either a twin tyre impactor or shot bag impactor. When using a twin tyre impactor, its masses shall not make contact with the test piece during the impact.

5.4.5 For asymmetric materials that are intended for installation where the risk of impact is from both sides, carry out the test on both sides.

For asymmetric materials where the required classification is for one face only, solely the designated face shall be tested and this shall be reported in the test report.

5.4.6 Inspect the test piece after impact and note whether

- a) it remains unbroken,
- b) it broke in accordance with either the requirements of [4.2](#) or [4.3](#) or
- c) it broke and failed to conform to the requirements of [4.2](#) or [4.3](#).

5.4.7 If any of the initial four test pieces fails to conform to the requirements of [4.2](#) or [4.3](#), terminate the procedure. If all four test pieces either do not break or else break according to the criteria given in [4.2](#) or [4.3](#), and it is required by manufacturer to test the material to a higher impact level, increase the drop height to the next level (see [Table 1](#)). Repeat the test on four more samples of the same material.

If the material remained unbroken, the same sample(s) may be used.

5.4.8 Report all test results in accordance with [Clause 7](#).

6 Classification

6.1 General

Glass conforming to this International Standard is classified in accordance with the following:

- a) its performance under the impact test;

- b) the drop height at which breakage occurred;
- c) the drop height at which the product satisfied the specifications of [4.2](#);
- d) the drop height at which the product satisfied the specifications of [4.3](#).

6.2 Drop height class

Glass shall be classified as follows:

- a) Class 3 — Material that conforms to the requirements of [4.2](#) or [4.3](#) when tested by the method given in [5.4](#) at a drop height of 190 mm with the double tyre impactor or 300 mm with the lead shot bag;
- b) Class 2 — Material that conforms to the requirements of [4.2](#) or [4.3](#) when tested by the method given in [5.4](#) at drop heights of 190 mm with the double tyre impactor or 300 mm with the lead shot bag and 450 mm with both impactors;
- c) Class 1 — Material that conforms to the requirements of [4.2](#) or [4.3](#) when tested by the method given in [5.4](#) at drop heights of 190 mm with the double tyre impactor or 300 mm with the lead shot bag, 450 mm with both impactors and 1 200 mm with both impactors.

6.3 Mode of breakage

If all test pieces remain unbroken at the drop height appropriate to its intended drop height class, the mode of breakage shall be determined as per [Annex E](#). The mode of breakage shall be described as follows.

- a) Type A — Numerous cracks appear forming separate fragments with sharp edges, some of which are large.
- b) Type B — Numerous cracks appear, but the fragments hold together and do not separate.
- c) Type C — Disintegration occurs, leading to a large number of small particles which are relatively harmless.

NOTE The descriptions of the mode of breakage are intended to convey the following information (see [Annex E](#)):

- Type A — mode of breakage typical of annealed glass;
- Type B — mode of breakage typical of laminated glass and wired glass;
- Type C — mode of breakage typical of toughened glass.

6.4 Performance classification

The performance classification of a glass product shall be given as follows:

$\alpha(\beta)\varphi$

where

- α is the highest drop height class ([6.2](#)) at which the product either did not break or broke in accordance with [4.2](#) or [4.3](#);
- β is the mode of breakage;
- φ is the highest drop height class ([6.2](#)) at which the product either did not break or when it did break, broke in accordance with [4.2](#).

The retention criterion, ϕ , is met when no break occurs or numerous cracks appear, but no shear or opening is allowed within the test piece through which a (76 ± 1) mm diameter sphere can pass when a maximum force of 25 N is applied in accordance with [Annex C](#).

When a glass product breaks at a drop height of 190 mm with a double tyre impactor or 300 mm with a lead shot bag and the breakage is not in accordance with [4.2](#), then the value of ϕ quoted shall be zero.

EXAMPLE 1 A set of laminated glass test pieces were impacted with the following results:

- at 190 mm/300 mm: three test pieces did not break while one test piece broke in accordance with [4.2](#);
- at 450 mm: all four test pieces broke in accordance with [4.2](#);
- at 1 200 mm: all four test pieces broke and failed to comply with [4.2](#) or [4.3](#).

Classification: 2(B)2

EXAMPLE 2 A set of thermally toughened soda lime silicate glass test pieces were impacted with the following results:

- at 190 mm/300 mm: all four test pieces did not break;
- at 450 mm: all four test pieces broke in accordance with [4.3](#);
- at 1 200 mm: all four test pieces broke in accordance with [4.3](#).

Classification: 1(C)3

EXAMPLE 3 A set of thermally toughened soda lime silicate glass test pieces were impacted with the following results:

- at 190 mm/300 mm: two test pieces did not break and two test pieces broke in accordance with [4.3](#);
- at 450 mm: all four test pieces broke in accordance with [4.3](#);
- at 1 200 mm: all four test pieces broke in accordance with [4.3](#).

Classification: 1(C)0

7 Test report

The test report shall contain at least the following information:

- a) the type and nominal thickness of the glass product;
- b) the dimensions of test pieces;
- c) the test method and type of impactor used (twin tyre or shot bag), with reference to this International Standard, i.e. ISO 29584:2015;
- d) the behaviour at each drop height for each test piece, including whether the test piece broke;
- e) if the test piece broke, the mode of breakage, and whether breakage was in accordance with the criteria of [4.2](#), [4.3](#) or neither;
- f) the date of the last calibration of the test rig according to [Annex B](#);
- g) in the case of applied films, whether the film was clamped in the frame;
- h) the name and the address of the testing laboratory;
- i) the test identification to enable test data to be traced;
- j) the date of test report;

- k) the name of manufacturer, processor and supplier of the test material;
- l) the declared description of the material tested (including product type, trade name or other means of identification);
- m) in the case of asymmetric materials, the classification of both surfaces unless only one impact side has been tested, in which case the classification and the surface that was impacted shall be reported.

Annex A (normative)

Method of fabrication of the shot bag impactor

A.1 [Figure 7](#) shows all the materials required for fabricating a shot bag (also called leather bag) along with the respective dimensions. The dimensions indicated on the right of [Figure 6](#) are those specified in this International Standard. The dimensions indicated on the left of [Figure 6](#) are those required for fabricating a shot bag. A shot bag compliant with this International Standard can be fabricated by placing the upper double nut position at 90 mm from the top of the bag and the lower double nut position at 40 mm from the bottom of the bag.

A.2 Before starting, loosen the strap of the leather bag and remove the internal rubber bag.

A.3 At the hanging strap position of the bag, provide a hole with a knife in a size to allow a threaded metal rod of diameter 10 mm to pass through.

A.4 Install eye nut 1 and plain washer 2 together with nut 3 at about 90 mm from the upper end of the threaded metal rod to form a double nut (for locking) and fix them securely in place. Then install four nuts fastening them retrospectively. Next, install a spring washer 4 and a sleeve nut 5.

A.5 At 40 mm from the other end of the threaded metal rod 10, form a double nut using hexagonal nut 3 to fix the rod in place. Install a spring washer 4 and metal washer 11 and thrust the rod 10 through the centre of the bottom of the leather bag 8 from inside.

A.6 Install metal washer 11 and spring washer 4 on the threaded metal rod extruding out of the bottom of the leather bag, fasten with a hexagonal nut 3 forming a double nut in combination with an eye nut 1, and fix the rod in place. (For safety during testing, if the end of the threaded metal rod does not extrude from the eye nut due to any thickness error with the metal or spring washers, change the distance from the end from 40 mm to 45 mm and repeat steps [A.5](#) and [A.6](#).)

A.7 At the other end of the rod, install plain washer 2 and thrust the rod through the hanging strap. Install another plain washer 2, then, fasten with eye nut 1. (As in step [A.6](#), if the end of the rod does not extrude through the eye nut, change the distance from the upper end from 90 mm to about 95 mm and redo steps [A.3](#) and [A.6](#).)

The five nuts above sleeve nut 5 and plain washer 2 are to hang the leather bag following the specified dimensions.

A.8 Fix the lace from the bottom up to about half of the total lacing length.

A.9 Place the leather bag ([A.8](#)), three rolls of tape, and hose clamp 6 on a spring balance, then fill the bag with lead shots until the mass of the total assembly reaches $(45,0 \pm 0,1)$ kg.

A.10 Fix the remaining lace, and fasten the sleeve nut section of the leather bag neck with hose clamp 6.

A.11 Hang the completed leather bag weighing $(45,0 \pm 0,1)$ kg with a rope from the ceiling or other elevated section.

A.12 Tape the leather bag to cover its entire surface using three rolls of the specified type of tape in diagonal, overlapping manner. Tape the neck section separately. (The “neck” refers to the section extending from the top of the bag to about 120 mm downward.)

[A.13](#) to [A.26](#) describe the taping procedure.

A.13 Shape the lifted bag properly by tapping with the hand.

A.14 Measure the circumference of the section where the diameter is the maximum and calculate the diameter. The maximum diameter shall be about 250 mm. (If the maximum diameter significantly deviates from the specified value, there is no way to correct it. In that case, the only solution is probably to replace the bag with another one or remake the shot bag.)

A.15 Assign code I to the leather seam on which the lace is located. Assign codes II, III, IV, V and VI to the other seams counter clockwise from code I (see [Figures A.1](#) and [A.2](#)).

Dimensions in millimetres

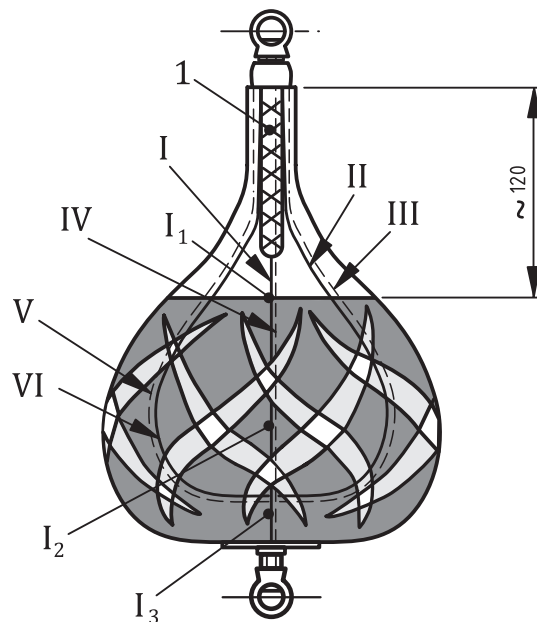

Key

- | | | | |
|-----|---------------------------------|----------------|--|
| 1 | lace | V | seam 5 (at the back of the bag) |
| I | seam 1 (includes lace) | VI | seam 6 |
| II | seam 2 | I ₁ | taping point 1 on seam 1 (at base of neck portion, 30mm from lace portion) |
| III | seam 3 (at the back of the bag) | I ₂ | taping point 2 on seam 1 (at maximum circumference) |
| IV | seam 4 (at the back of the bag) | I ₃ | taping point 3 on seam 1 (30mm outside the metal washer) |

Figure A.1 — Side elevation of shot bag (taping points are only shown on seam but they are on all seams)

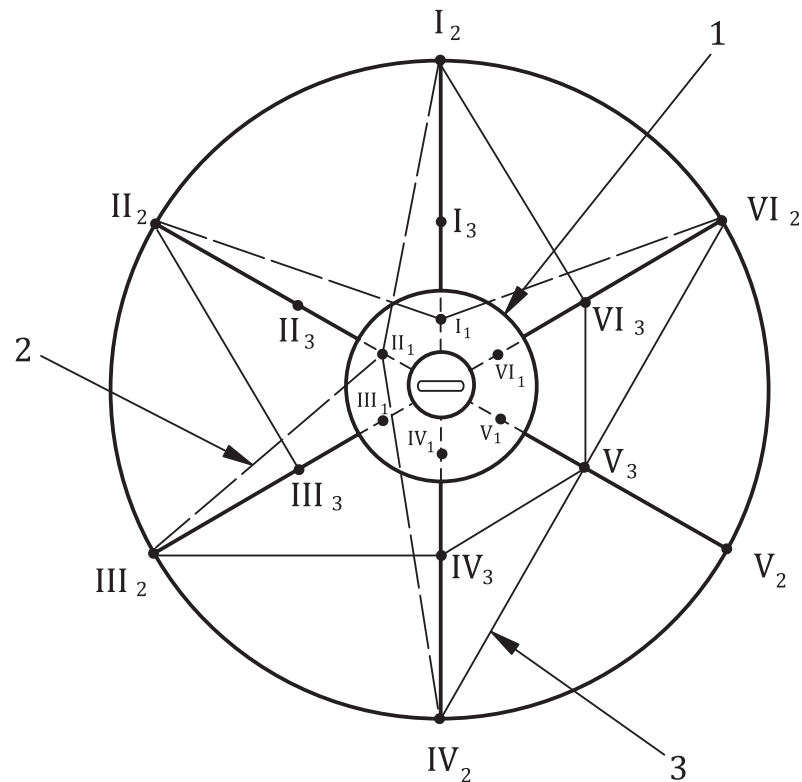

Key

- 1 metal washer
- 2 example taping lines on upper part of bag
- 3 example taping lines on lower part of bag
- I₁, II₁, III₁, IV₁, V₁, VI₁ upper taping points 1 (30 mm below lace) on seams I-VI
- I₂, II₂, III₂, IV₂, V₂, VI₂ middle taping points 2 (at maximum circumference) on seams I-VI
- I₃, II₃, III₃, IV₃, V₃, VI₃ lower taping points 3 (30 mm outside the metal washer) on seams I-VI

Figure A.2 — Plan of shot bag from below

A.16 As shown in [Figures A.1](#) and [A.2](#), assign code I₁ to the section about 30 mm below the lower end of the lace section, code I₂ to the section with the maximum diameter, code I₃ to the section about 30 mm outside the metal washer. In the same manner, assign code II₁, II₂, II₃, III₁, III₂, and III₃ and so on through VI₁, VI₂ and VI₃ in sequence.

A.17 Start taping at I₁ by applying it diagonally at an angle of 45° to reach point III₃ via point II₂. The tape should be lightly extended without any strain on it. Cut the tape at point III₃.

A.18 In the same manner, apply the tape lightly, without strain, to cover points II₁, III₂ and IV₃; III₁, IV₂ and V₃; IV₁, V₂ and VI₃; V₁, VI₂ and I₃; and VI₁, I₂ and II₃, cutting the tape at the end of each sequence.

A.19 Next, slant the tape by 45° in the opposite direction and tape the bag, covering I₁, VI₂ and V₃; II₁, I₂ and VI₃; III₁, II₂ and I₃; IV₁, III₂ and II₃; V₁, IV₂ and III₃; and VI₁, V₂ and IV₃ in the same manner as in steps [A.17](#) and [A.18](#).

A.20 Around the tape applied (A.19), apply the tape in two rows on the right and left sides, completing twofold taping in total of five rows, also without strain.

Figure A.1 shows the view as taping is completed to this point. The sections shaded in darker grey are where the tape is applied in five rows and overlapped in four layers while the sections shaded in lighter grey where the tape is applied in twofold five rows.

(The total tape consumption up to this point amounts to 0,8 to 0,9 of a roll.)

The following are three tips on taping.

- a) Avoid neighbouring rows overlapping when carrying out twofold taping in five rows. Overlapping causes wrinkles. In particular, the upper and lower sections of the respective rows can easily overlap. If this happens, tape locations cannot be correctly recognized in the subsequent steps.
- b) Do allow the tape to be put under strain. Strain hardens the bag.
- c) Ensure that tapes cross at the section where the diameter is greatest.

A.21 Next, shift the tape by half its width and apply it continuously, without cutting it, to achieve twofold taping in five rows. Start at point I₁ to pass through points II₂, III₃, IV₃, V₃, VI₂, I₁, in this order (see Figure A.2). Force the tape to be redirected at the bottom of the bag to apply it from point III₃ to point V₃ via IV₃. (Wrinkles are permitted in doing so.) Then, turn the taping direction to allow taping from point V₃ to point I₁ via point VI₂ (see Figure A.3).

A.22 From point I₁ where taping ended in the previous step, extend it (wrinkles permitted) to pass through II₁, III₂, IV₃, V₃, VI₃, I₂ and II₁ (see Figure A.3). In the same manner, apply the tape to cover III₁, IV₂, V₃, VI₃, I₃, II₂ and III₁; IV₁, V₂, VI₃, I₃, II₃, III₂ and IV₁; V₁, VI₂, I₃, II₃, III₃, IV₂ and V₁; VI₁, I₂, II₃, III₃, IV₃, V₂ and VI₁, then return to I₁. Then repeat the same procedure again to achieve twofold taping (see Figure A.3).

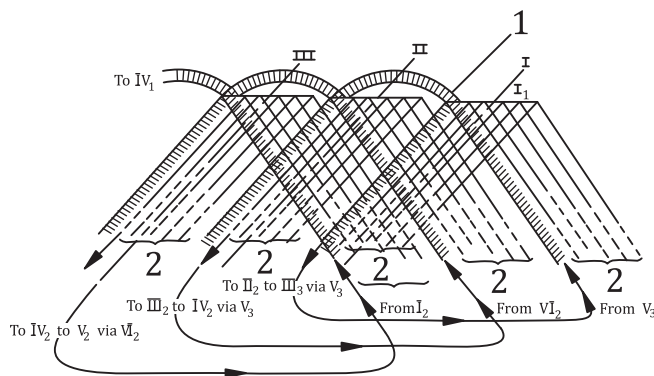

- Key**
- 1 starting point (shift the tape by half a width)
 - 2 five rows twofold

Figure A.3 — Taping method

A.23 As step A.22 is completed, the tape returns to point I₁. Next, shift the tape to the right, and follow steps A.21 and A.22 to perform the same procedure and achieve twofold taping in five rows. (Never strain the tape and apply it carefully in five rows.)

When the steps above are completed, taping is completed in eight folds in five rows over the sections shaded darkly in Figure A.1 and in the lighter-shaded sections, in four folds in five rows. (The total tape consumption up to this point amounts to 1,8 to 1,9 rolls.)

A.24 Reinforce the sections shown in white and the light grey shaded areas in [Figure A.4](#) so that taping is achieved in eight folds. To reinforce, apply the tape in four folds and in several rows so that it crosses at the section where the diameter is the greatest. Now the tape is applied in eight folds over the white sections and light grey sections (see [Figure A.4](#)).

(The total tape consumption up to this point amounts to 2,6 to 2,7 rolls.)

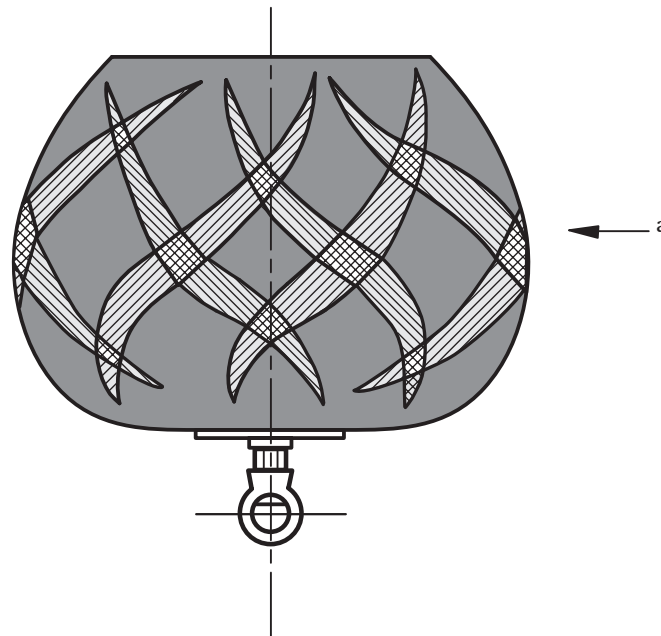

Key

- a Applying the tape in four folds over the white and light grey sections achieves taping at the intersection in eight folds.

Figure A.4 — Taping reinforcement

A.25 As it is specified that the body and neck sections be taped separately, start taping for the neck portion below the upper eye nut to proceed in a spiral manner downward by shifting the tape by half its width until the tape reaches the lace section. (Apply taping until the tape becomes flush with the point already taped in the previous steps up to step [A.24](#).) The “neck” refers to the portion extending from the top of the bag to about 120 mm below (see [Figure A.1](#)).

Taping in a spiral manner causes part of the tape to be not in contact with the bag as shown in [Figure A.5](#). Apply pressure to these parts of the tape so that contact with the bag is established.

Repeat this operation four times to achieve taping in eight folds.

(The total tape consumption up to this point amounts to about 2,9 rolls.)

A.26 As this Annex specifies that taping be performed using three rolls of tape, apply the remaining portion of the tape at random points with allowance given for retention of the tape used for reinforcement so that the tape is evenly applied.

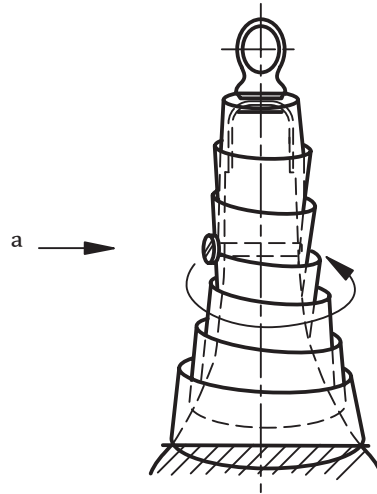

Key

- a Apply the tape in a spiral manner overlapping by half its width.

Figure A.5 — Taping impactor neck (view when taping is completed around the neck)

Annex B (normative)

Calibration of the test rig

B.1 Calibration procedure

B.1.1 The calibration test piece shall be a 10 mm thick pane of thermally toughened soda lime silicate safety glass according to ISO 16293-1^[4] made from soda lime silicate float glass.

The dimensions of the calibration test piece shall be (876 ± 2) mm \times $(1\,938 \pm 2)$ mm.

Remove all masking and protection material from the calibration test piece and condition it for a minimum of 12 h at the calibration temperature of (20 ± 5) °C.

Fix a constantan rosette strain gauge to the centre of the pane in order to measure the horizontal and vertical micro-deformation. The precision strain gauge⁴⁾ shall be of the following type:

- a) resistance at 24 °C: $(350,00 \pm 1,75)$ Ω or $(120,0 \pm 0,6)$ Ω ;
- b) length of the grid: 3,18 mm to 5 mm;
- c) width of the grid: 1,4 mm to 4,57 mm.

B.1.2 Place the calibration test piece in the clamping frame so that the strain gauge is on the opposite side to the impact. When clamped, the rubber shall be compressed by not less than 5 % and not more than 10 % of the thickness.

Use either a twin tyre impactor or shot bag impactor.

When using a twin tyre impactor, inflate both tyres to a pressure of $(0,35 \pm 0,02)$ MPa.

Raise the impactor to the lowest drop height and stabilize. At the drop height, the suspension cable shall be taut and the axis of the impactor and cable shall be in line.

B.1.3 Release the impactor, stabilized in the launch position, so that it falls with a pendular movement without initial velocity. The impact shall occur at the centre of the calibration test piece striking it only once.

Measure and record the horizontal and vertical micro-deformation. Record three measurements per drop height.

B.1.4 Repeat the procedure in [B.1.3](#) for each drop height (see [Table B.1](#)).

4) The CEA-06-125WT-350 is an example of a suitable product available commercially. This information is given for the convenience of users of this International Standard and does not constitute an endorsement by ISO of this product.

Table B.1 — Drop heights for the calibration test

Drop height mm
200
250
300
450
700
1 000
1 200

B.2 Calibration report

The calibration report shall contain at least the following information:

- a) the name, address and reference to impact rig;
- b) the name of test engineer, date of calibration;
- c) the type and nominal thickness of glass;
- d) the dimensions of the calibration test piece;
- e) the type of impactor;
- f) the description of the test rig (material e.g. steel, etc.; type of clamping, i.e. continuous, bolted, etc.);
- g) all measured values per drop height;
- h) the curves (drop height versus horizontal micro-deformation and drop height versus vertical micro-deformation) based upon the mean values with the type of strain gauge used;
- i) the test method used, with reference to this Annex of this International Standard, i.e. ISO 29584:2015, Annex B.

B.3 Reference calibration curve

The curves obtained after the calibration procedure shall be in accordance with the reference calibration curves within a tolerance of $\pm 10\%$ (see [Tables B.2](#) and [B.3](#) and [Figures B.1](#) and [B.2](#) for a twin tyre impactor and [Tables B.4](#) and [B.5](#) and [Figures B.3](#) and [B.4](#) for a lead shot bag, respectively) in order to ensure that the energy transferred to the test piece by the impactor during the test is equivalent to the energy required for the classification.

B.4 Calibration frequency

The calibration procedure shall be undertaken every three years. However, if a major change, e.g. change of structural components, clamping system, etc., is made to the rig, then it shall be recalibrated prior to testing.

Table B.2 — Reference mean peak horizontal micro-strain for twin tyre impactor

Drop height mm	Mean value $\epsilon_{TT,h} \times 10^6$	Mean value- minus 10 %	Mean value- plus 10 %
200	1 275	1 147	1 402
250	1 418	1 276	1 559
300	1 542	1 388	1 696
450	1 793	1 613	1 972
700	2 063	1 857	2 269
1 000	2 327	2 094	2 559
1 200	2 503	2 252	2 753

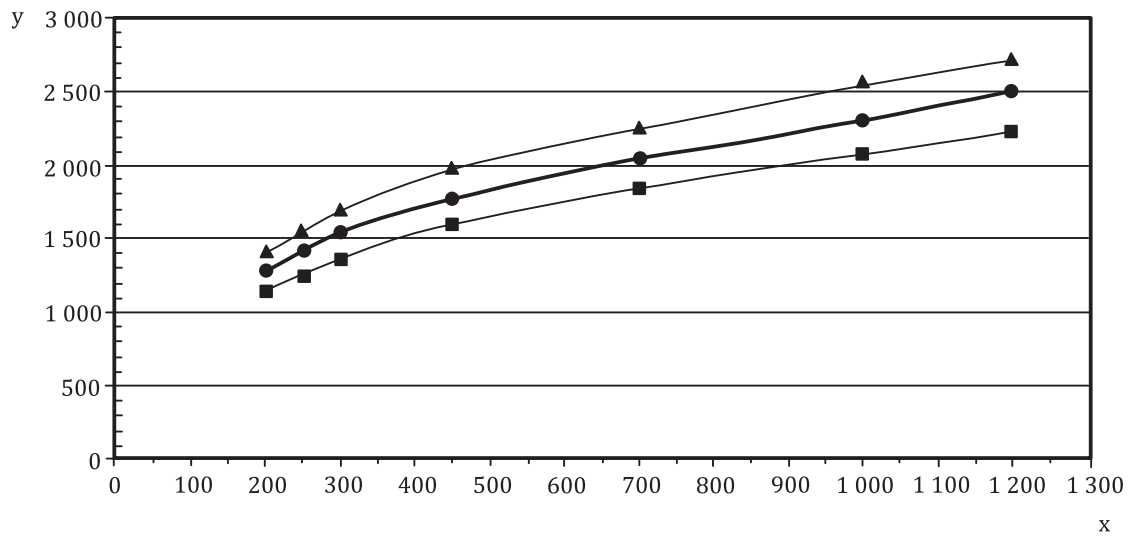

Key

● mean value

■ mean value minus 10 %

▲ mean value plus 10 %

x drop height

y mean peak horizontal micro-strain for twin tyre impactor ($\epsilon_{TT,h} \times 10^6$)

Figure B.1 — Reference horizontal micro-strain calibration curve for twin tyre impactor

Table B.3 — Reference mean peak vertical micro-strain for twin tyre impactor

Drop height mm	Mean value $\epsilon_{TT,v} \times 10^6$	Mean value- minus 10 %	Mean value- plus 10 %
200	805	724	885
250	911	820	1 002
300	1 013	912	1 114
450	1 181	1 063	1 299
700	1 389	1 250	1 528
1 000	1 601	1 440	1 761
1 200	1 742	1 567	1 916

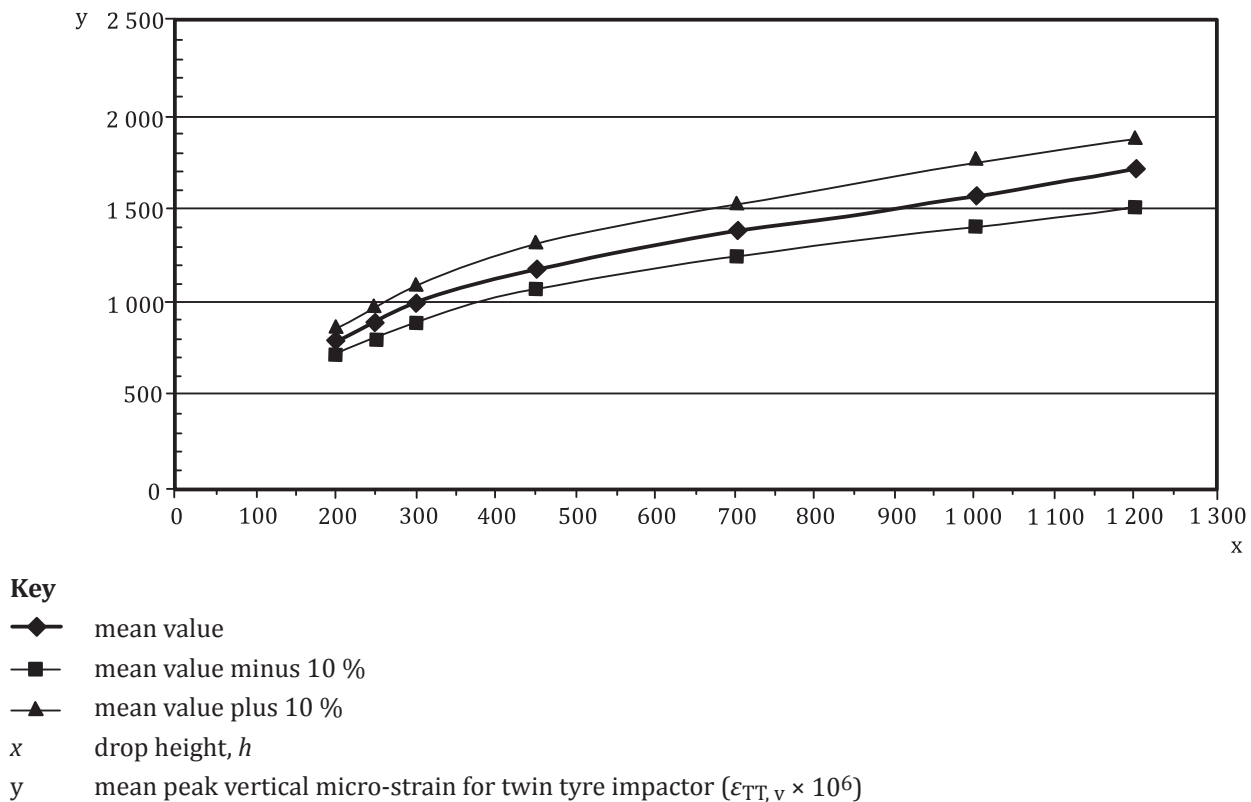
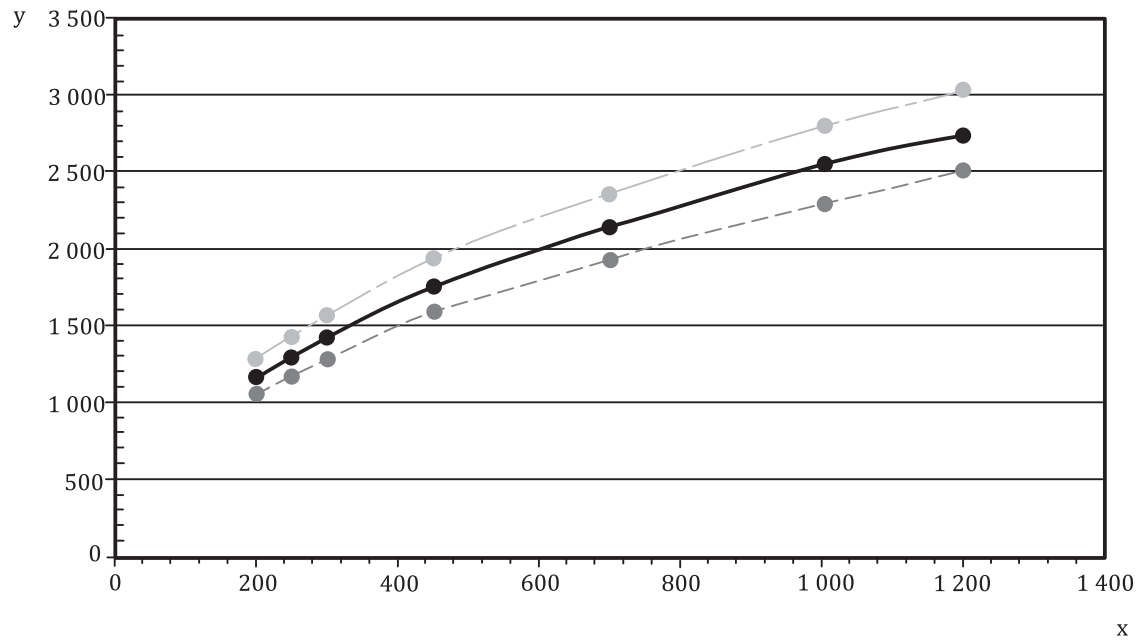

Figure B.2 — Reference vertical micro-strain calibration curve for twin tyre impactor

Table B.4 — Reference mean peak horizontal micro-strain for shot bag impactor

Drop height mm	Mean value $\epsilon_{SB,h} \times 10^6$	Mean value- minus 10 %	Mean value- plus 10 %
200	1 174	1 057	1 291
250	1 298	1 169	1 428
300	1 434	1 290	1 577
450	1 762	1 586	1 939
700	2 159	1 943	2 375
1 000	2 567	2 311	2 824
1 200	2 764	2 487	3 040



Key

- mean value
- mean value minus 10 %
- mean value plus 10 %
- x drop height, h
- y mean peak horizontal micro-strain for shot bag impactor ($\epsilon_{SB,h} \times 10^6$)

Figure B.3 — Reference horizontal micro-strain calibration curve for shot bag impactor

Table B.5 — Reference mean peak vertical micro-strain for shot bag impactor

Drop height mm	Mean value $\epsilon_{SB,v} \times 10^6$	Mean value- minus 10 %	Mean value- plus 10 %
200	843	759	928
250	943	849	1 038
300	1 029	926	1 131
450	1 249	1 124	1 373
700	1 512	1 361	1 664
1 000	1 810	1 629	1 991
1 200	1 963	1 767	2 160

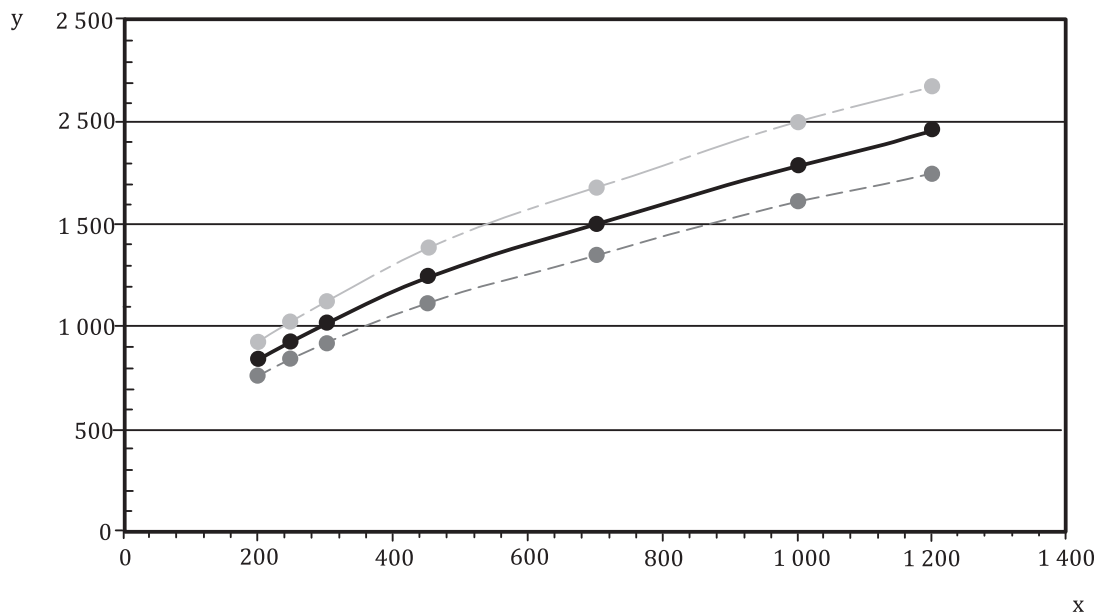

Key

—●— mean value

—●— mean value minus 10 %

—●— mean value plus 10 %

x drop height h

y mean peak vertical micro-strain for shot bag impactor ($\epsilon_{SB,v} \times 10^6$)

Figure B.4 — Reference vertical micro-strain calibration curve for shot bag impactor

Annex C (normative)

Sphere penetration test

C.1 Probe assembly

The probe assembly shall consist of a sphere⁵⁾ of diameter (76 ± 1) mm connected to an arm with a device⁶⁾ for measuring when a maximum force of 25 N has been applied. An example of a probe assembly is shown in [Figure C.1](#).

C.2 Operation

The probe assembly shall be held so that it is horizontal. It shall then be pushed into any opening formed in the test piece. The weakest point of resistance shall be selected. A horizontal force shall be applied until either

- a) a maximum force of 25 N has been achieved without penetration by the sphere (the test piece shall be deemed to have passed the test) or
- b) the maximum diameter of the sphere has passed through the plane of the test piece without a force of 25 N being achieved (the test piece shall be deemed to have failed the test).

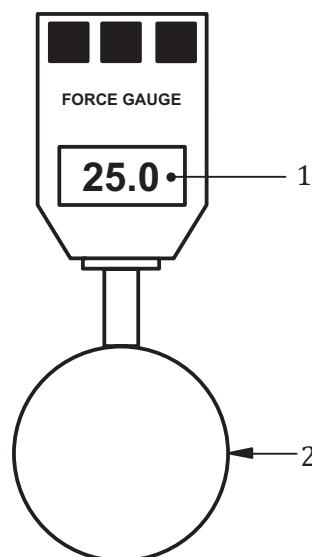

Key

- 1 force indicated in Newtons
- 2 76 mm diameter sphere

Figure C.1 — Example of a probe to verify free passage of a 76 mm diameter sphere

5) A sphere available from Euromatic is an example of a suitable product available commercially. This information is given for the convenience of users of this International Standard and does not constitute an endorsement by ISO of this product.

6) The portable force indicator, model PF1-200N, is an example of a suitable product available commercially. This information is given for the convenience of users of this International Standard and does not constitute an endorsement by ISO of this product.

Annex D (informative)

Example of a test rig

See [Figures D.1 to D.3](#).

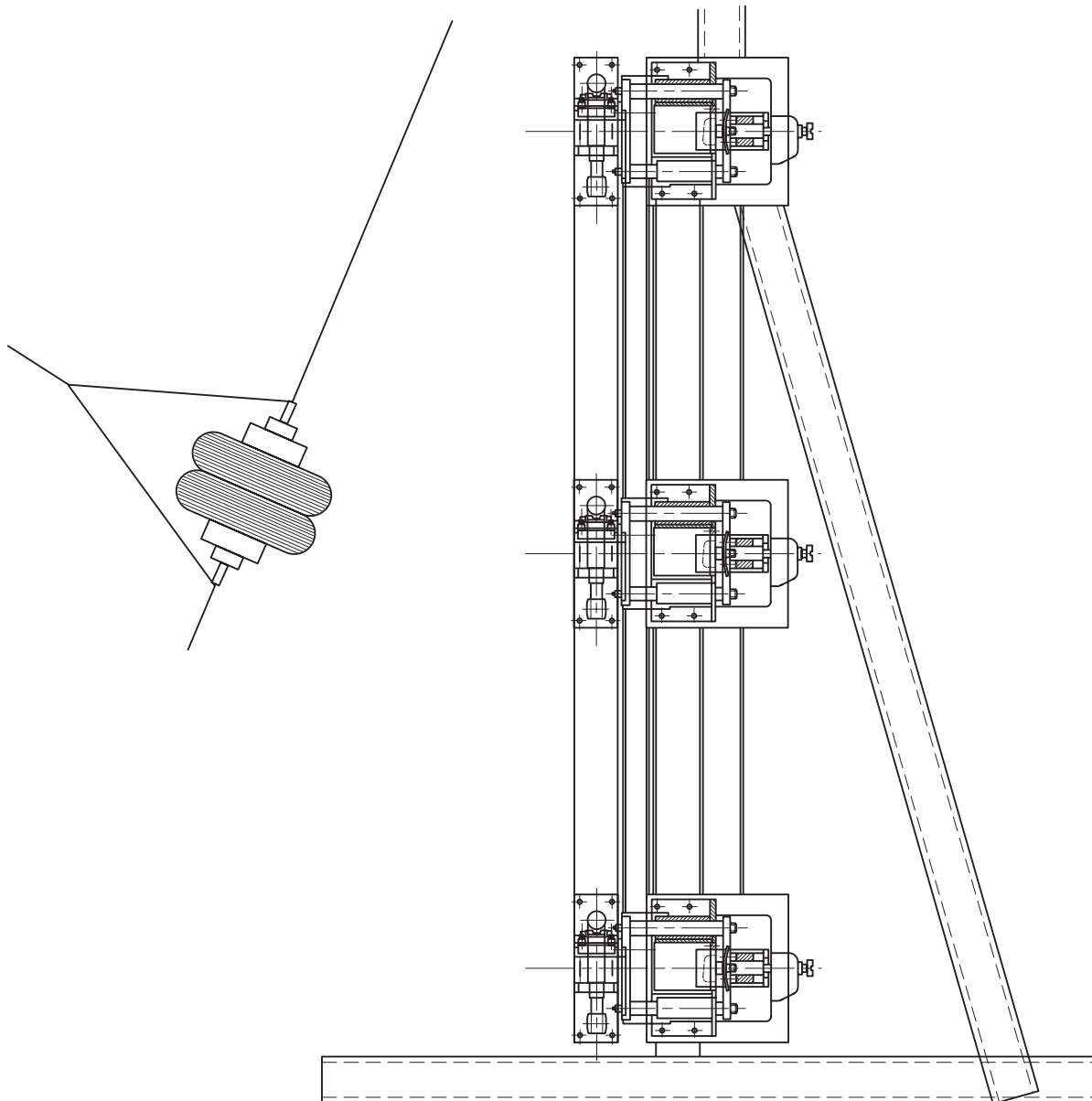
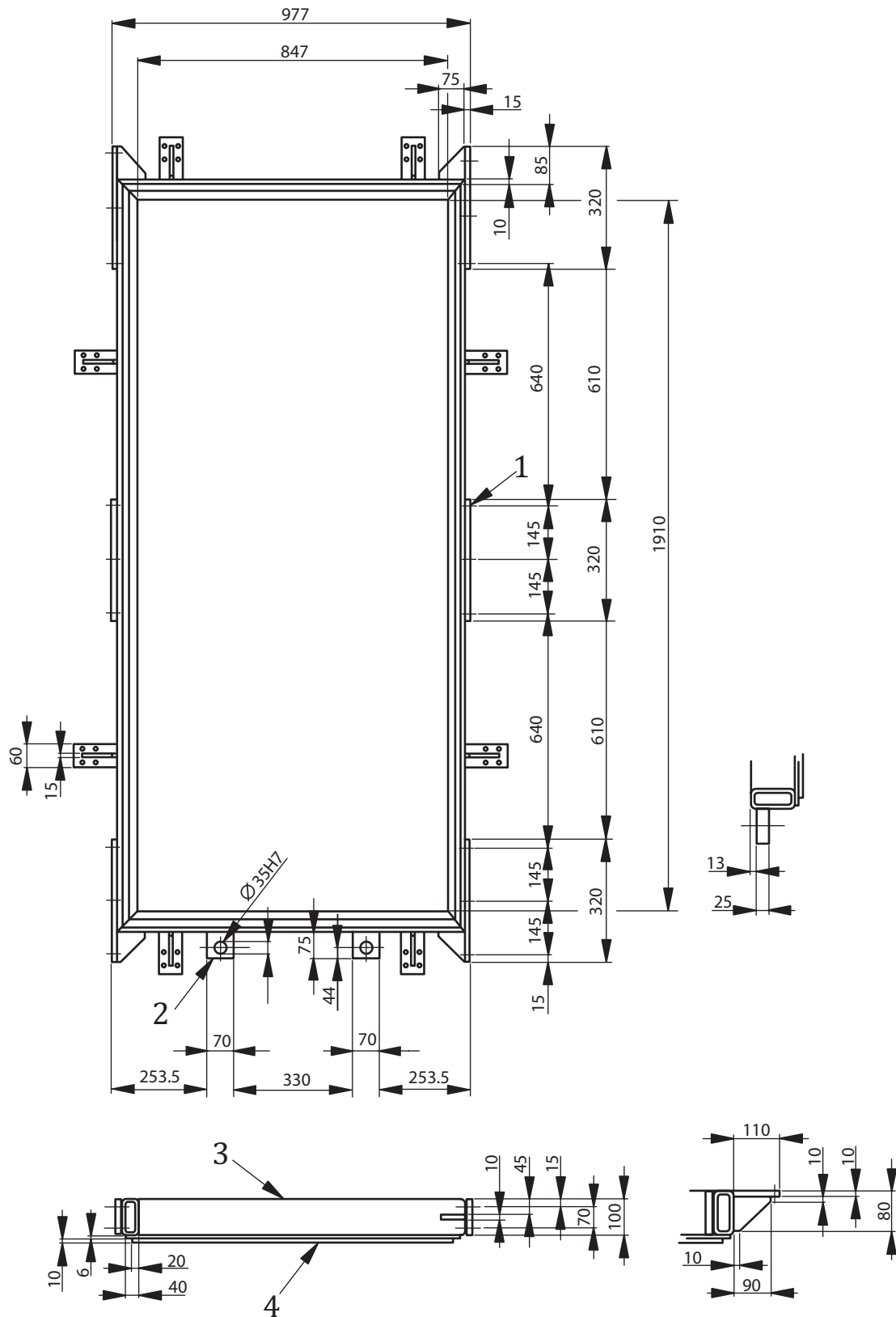

Figure D.1 — Side elevation of the main frame with the impactor

Dimensions in millimetres



Key

- | | | | |
|---|--------------------------------|---|--|
| 1 | 12 holes $\text{Ø} \text{M}12$ | 3 | $100 \times 50 \times 8$ right hand side |
| 2 | see detail | 4 | rubber strips 20×10 |

Figure D.2 — Component No. 1

Dimensions in millimetres

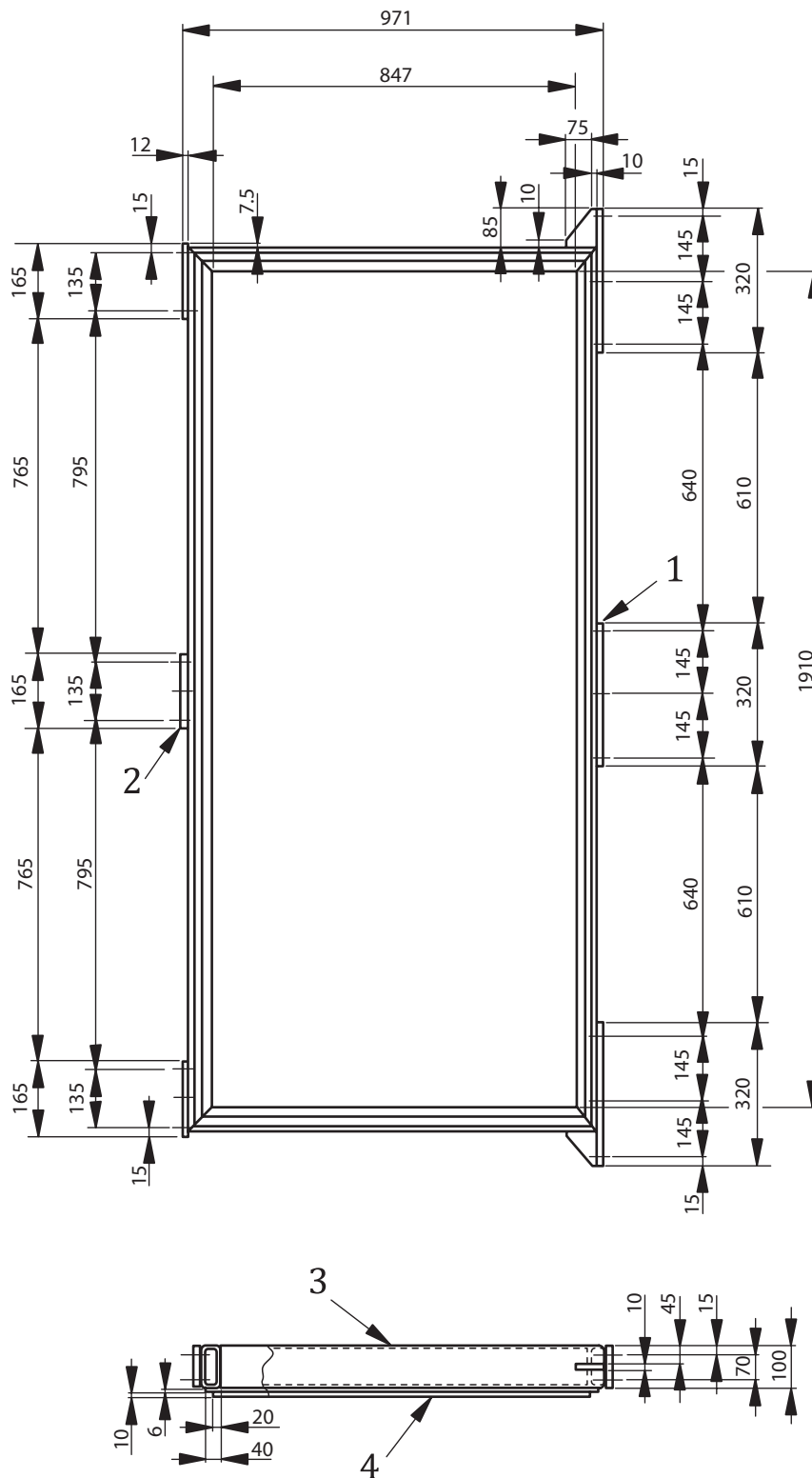

Key

- | | | | |
|---|----------------------------|---|------------------------------|
| 1 | 18 holes \varnothing M12 | 3 | 100 × 50 × 8 right hand side |
| 2 | 12 holes \varnothing M12 | 4 | rubber strips 20 × 10 |

Figure D.3 — Component No. 2

Annex E (informative)

Terms and definitions of glass types

E.1

annealed glass

glass, with no restriction on composition, that has been subjected to controlled cooling to reduce the presence of residual stress in the glass thus allowing easy cutting

EXAMPLES Float glass, sheet glass, patterned glass and wired glass.

Note 1 to entry If annealed glass is broken and penetrated the resulting glass edges are sharp and capable of producing piercing injuries. Breakage typical of type A.

E.2

thermally toughened soda lime silicate safety glass

glass within which a permanent surface compressive stress has been induced by a controlled heating and cooling process in order to give it greatly increased resistance to mechanical and thermal stress and prescribed fragmentation characteristics

Note 1 to entry Thermally toughened glass is difficult to penetrate, but if broken it fragments into small relatively harmless pieces. Breakage typical of type C.

E.3

heat-strengthened soda lime silicate glass

glass within which a permanent surface compressive stress has been induced by a controlled heating and cooling process in order to give it increased resistance to mechanical and thermal stress and prescribed fragmentation characteristics

Note 1 to entry When penetrated, heat-strengthened glass breaks like annealed glass. Breakage typical of type A.

E.4

chemically strengthened soda lime silicate glass

glass made by subjecting a soda lime silica glass to an ion exchange process in order to give it increased resistance to mechanical and thermal stress

Note 1 to entry The smaller diameter ions in the glass surface and edges are replaced with larger ones, which results in the glass surface and edges being placed in compression.

Note 2 to entry When penetrated, chemically strengthened glass breaks like annealed glass. Breakage typical of type A.

E.5

laminated safety glass

assembly consisting of a sheet of glass and sheet(s) of glass or plastics joined by one or more interlayers where in the case of breakage the interlayer serves to retain the glass fragments, limits the size of opening, offers residual resistance and reduces the risk of cutting or piercing injuries

Note 1 to entry Adapted from ISO 12543-1:2011, 2.8.

Note 2 to entry See ISO 12543-2.

Note 3 to entry Breakage is typical of type B.

E.6

wired glass

soda lime silicate glass, having metal wires (e.g. spot-welded square mesh) introduced and completely embedded during rolling, the structure of which remains largely held together if the glass fractures (cast and polished)

[SOURCE: ISO 6345:1990, 6.8]

Note 1 to entry When wired glass is broken after impact, it is held together by the wires. However, if penetrated, the edges are sharp. Breakage typical of type B.

E.7

polished wired glass

flat translucent, clear or tinted soda lime silicate glass having parallel and polished faces obtained by grinding and polishing the faces of wired patterned glass

Note 1 to entry When wired glass is broken, after impact it is held together by the wires. However, if penetrated, the edges are sharp. Breakage typical of type B.

E.8

film-backed annealed glass

glass which has a flexible plastics film adhered to one surface

Note 1 to entry When broken, the film holds the glass pieces together. Breakage typical of type B.

Annex F (informative)

Example of release mechanism

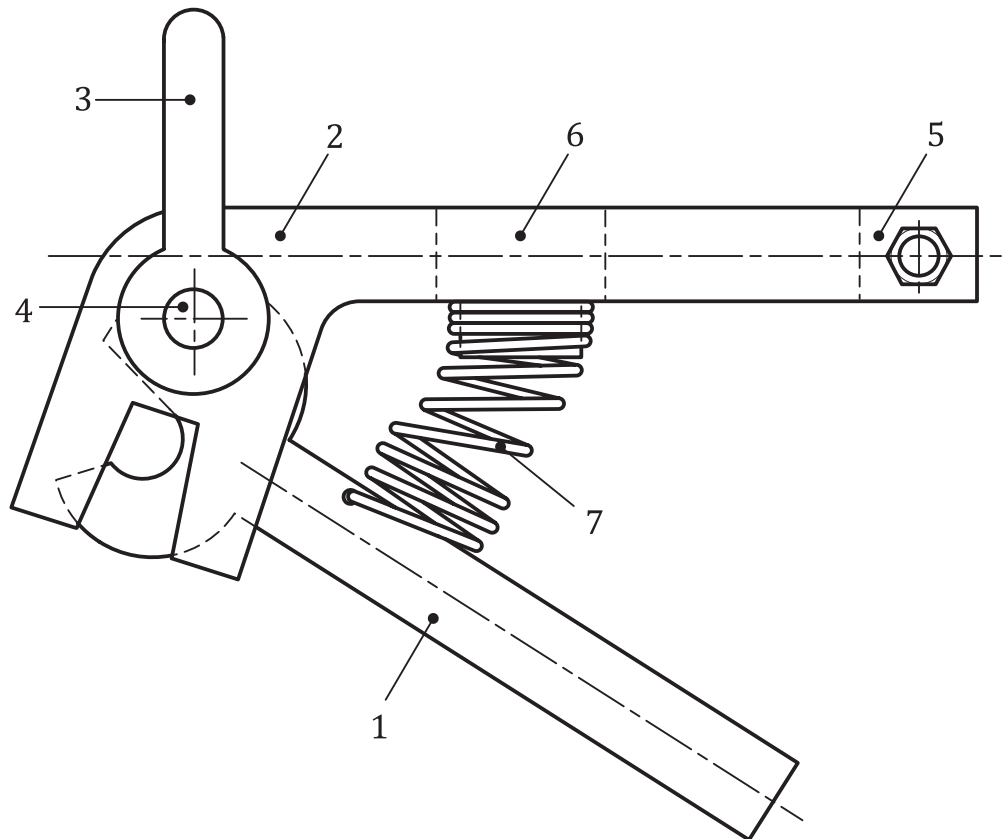

Key

1 Component 1
2 Component 2
3 Component 3
4 Component 4

5 Component 5
6 Component 6
7 Component 7

Figure F.1 — Example of release mechanism view 1

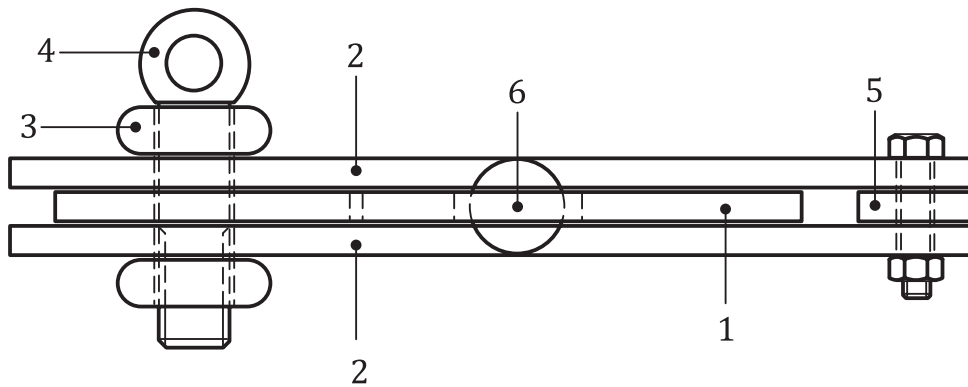

Key

- | | | | |
|---|-------------|---|-------------|
| 1 | Component 1 | 5 | Component 5 |
| 2 | Component 2 | 6 | Component 6 |
| 3 | Component 3 | 7 | Component 7 |
| 4 | Component 4 | | |

Figure F.2 — Example of release mechanism view 2

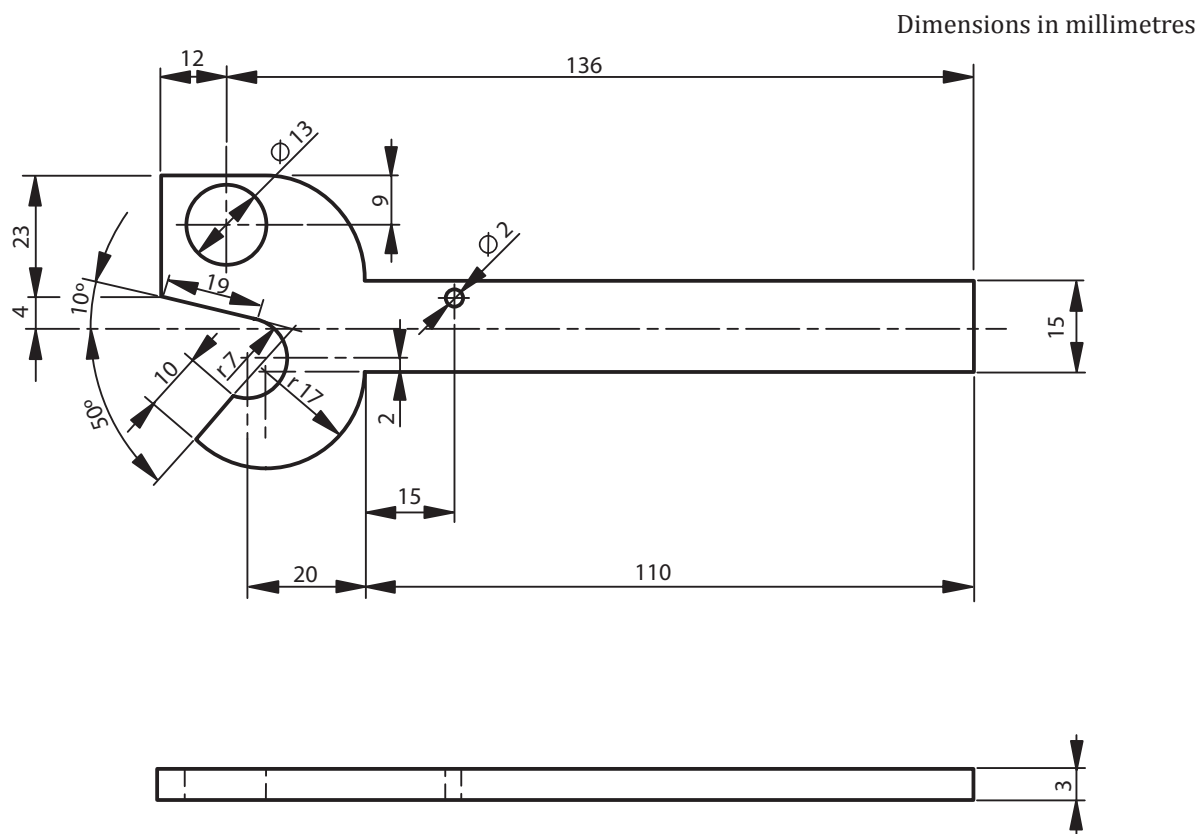

Figure F.3 — Component No.1

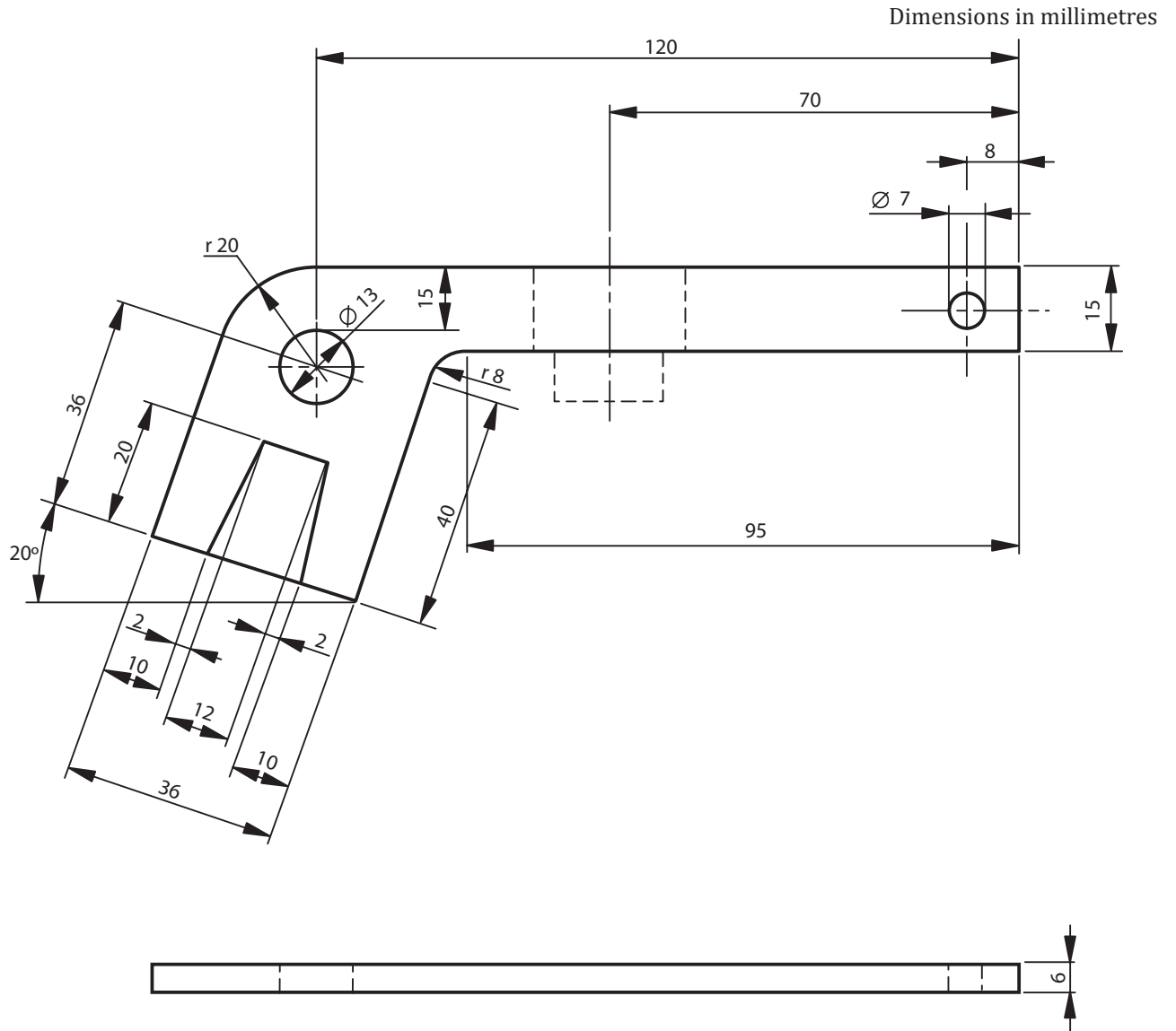

Figure F.4 — Component No.2

Dimensions in millimetres

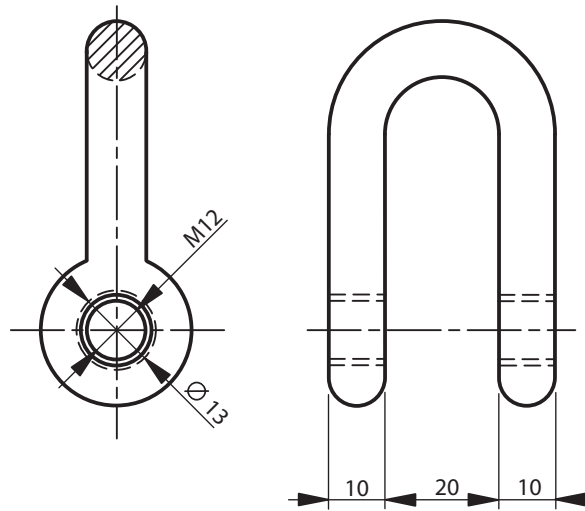

Figure F.5 — Component No.3

Dimensions in millimetres

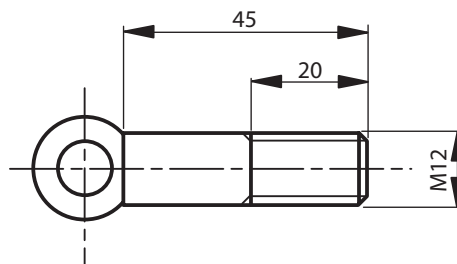

Figure F.6 — Component No.4

Dimensions in millimetres

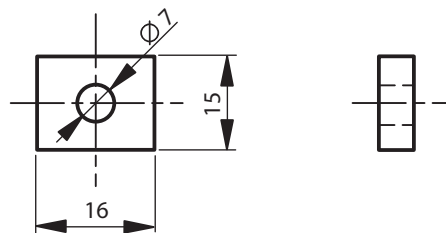

Figure F.7 — Component No.5

Dimensions in millimetres

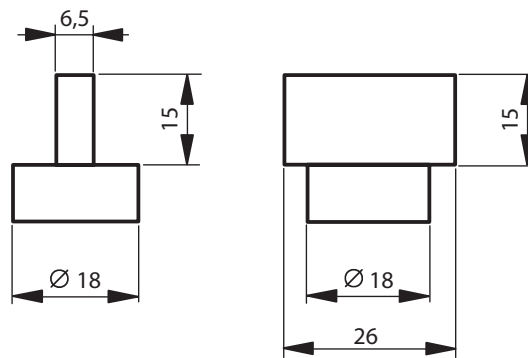

Figure F.8 — Component No.6



Figure F.9 — Component No.7

Bibliography

- [1] ISO 6345:1990, *Shipbuilding and marine structures — Windows and side scuttles — Vocabulary*
- [2] ISO 12543-1:2011, *Glass in building — Laminated glass and laminated safety glass — Part 1: Definitions and description of component parts*
- [3] ISO 12543-2, *Glass in building — Laminated glass and laminated safety glass — Part 2: Laminated safety glass*
- [4] ISO 16293-1, *Glass in building — Basic soda lime silicate glass products — Part 1: Definitions and general physical and mechanical properties*
- [5] EN 12600, *Glass in building — Pendulum test — Impact test method and classification for flat glass*

British Standards Institution (BSI)

BSI is the national body responsible for preparing British Standards and other standards-related publications, information and services.

BSI is incorporated by Royal Charter. British Standards and other standardization products are published by BSI Standards Limited.

About us

We bring together business, industry, government, consumers, innovators and others to shape their combined experience and expertise into standards-based solutions.

The knowledge embodied in our standards has been carefully assembled in a dependable format and refined through our open consultation process. Organizations of all sizes and across all sectors choose standards to help them achieve their goals.

Information on standards

We can provide you with the knowledge that your organization needs to succeed. Find out more about British Standards by visiting our website at bsigroup.com/standards or contacting our Customer Services team or Knowledge Centre.

Buying standards

You can buy and download PDF versions of BSI publications, including British and adopted European and international standards, through our website at bsigroup.com/shop, where hard copies can also be purchased.

If you need international and foreign standards from other Standards Development Organizations, hard copies can be ordered from our Customer Services team.

Subscriptions

Our range of subscription services are designed to make using standards easier for you. For further information on our subscription products go to bsigroup.com/subscriptions.

With **British Standards Online (BSOL)** you'll have instant access to over 55,000 British and adopted European and international standards from your desktop. It's available 24/7 and is refreshed daily so you'll always be up to date.

You can keep in touch with standards developments and receive substantial discounts on the purchase price of standards, both in single copy and subscription format, by becoming a **BSI Subscribing Member**.

PLUS is an updating service exclusive to BSI Subscribing Members. You will automatically receive the latest hard copy of your standards when they're revised or replaced.

To find out more about becoming a BSI Subscribing Member and the benefits of membership, please visit bsigroup.com/shop.

With a **Multi-User Network Licence (MUNL)** you are able to host standards publications on your intranet. Licences can cover as few or as many users as you wish. With updates supplied as soon as they're available, you can be sure your documentation is current. For further information, email bsmusales@bsigroup.com.

BSI Group Headquarters

389 Chiswick High Road London W4 4AL UK

Revisions

Our British Standards and other publications are updated by amendment or revision.

We continually improve the quality of our products and services to benefit your business. If you find an inaccuracy or ambiguity within a British Standard or other BSI publication please inform the Knowledge Centre.

Copyright

All the data, software and documentation set out in all British Standards and other BSI publications are the property of and copyrighted by BSI, or some person or entity that owns copyright in the information used (such as the international standardization bodies) and has formally licensed such information to BSI for commercial publication and use. Except as permitted under the Copyright, Designs and Patents Act 1988 no extract may be reproduced, stored in a retrieval system or transmitted in any form or by any means – electronic, photocopying, recording or otherwise – without prior written permission from BSI. Details and advice can be obtained from the Copyright & Licensing Department.

Useful Contacts:

Customer Services

Tel: +44 845 086 9001

Email (orders): orders@bsigroup.com

Email (enquiries): cservices@bsigroup.com

Subscriptions

Tel: +44 845 086 9001

Email: subscriptions@bsigroup.com

Knowledge Centre

Tel: +44 20 8996 7004

Email: knowledgecentre@bsigroup.com

Copyright & Licensing

Tel: +44 20 8996 7070

Email: copyright@bsigroup.com



...making excellence a habit.™