

BS ISO 29282:2011



BSI Standards Publication

Intelligent transport systems — Communications access for land mobiles (CALM) — Satellite networks

bsi.

...making excellence a habit.™

National foreword

This British Standard is the UK implementation of ISO 29282:2011.

The UK participation in its preparation was entrusted to Technical Committee EPL/278, Road transport informatics.

A list of organizations represented on this committee can be obtained on request to its secretary.

This publication does not purport to include all the necessary provisions of a contract. Users are responsible for its correct application.

© BSI 2011

ISBN 978 0 580 65915 7

ICS 03.220.01; 35.240.60

Compliance with a British Standard cannot confer immunity from legal obligations.

This British Standard was published under the authority of the Standards Policy and Strategy Committee on 31 August 2011.

Amendments issued since publication

Date	Text affected
------	---------------

**Intelligent transport systems —
Communications access for land mobiles
(CALM) — Satellite networks**

Systèmes intelligents de transport — Accès aux communications des services mobiles terrestres (CALM) — Applications utilisant les réseaux satellitaires





COPYRIGHT PROTECTED DOCUMENT

© ISO 2011

All rights reserved. Unless otherwise specified, no part of this publication may be reproduced or utilized in any form or by any means, electronic or mechanical, including photocopying and microfilm, without permission in writing from either ISO at the address below or ISO's member body in the country of the requester.

ISO copyright office
Case postale 56 • CH-1211 Geneva 20
Tel. + 41 22 749 01 11
Fax + 41 22 749 09 47
E-mail copyright@iso.org
Web www.iso.org

Published in Switzerland

Contents

Page

Foreword	iv
Introduction	v
1 Scope	1
2 Conformance	1
3 Normative references	1
4 Terms and definitions	2
5 Abbreviated terms	2
6 Background	3
6.1 Proprietary connectivity protocols	3
6.2 Internet connectivity	5
7 Requirements	5
7.1 General	5
7.2 Adoption of satellite standards and internationally adopted practices	6
7.3 CALM architecture and application grouping	6
7.4 CALM networking protocols	6
7.5 CALM medium service access points	6
7.6 CALM “ITS station management”	6
7.7 CALM using public wireless networks	7
7.8 Establishment and termination of medium specific sessions	7
7.9 Interface medium management	7
8 Medium access control (MAC)	7
8.1 Conformance	7
8.2 CALM satellite communications MMAE service primitives	7
8.3 Satellite communication MMAE	8
8.4 CALM session connection	10
8.5 CALM session disconnection	10
8.6 Change of satellite communications connection state	10
8.7 Retrieval of medium status	11
8.8 Satellite communications specific connection aspects	11
8.9 Satellite communications session disconnection	12
9 Test and conformance requirements	12
10 Declaration of patents and intellectual property	12
Bibliography	13

Foreword

ISO (the International Organization for Standardization) is a worldwide federation of national standards bodies (ISO member bodies). The work of preparing International Standards is normally carried out through ISO technical committees. Each member body interested in a subject for which a technical committee has been established has the right to be represented on that committee. International organizations, governmental and non-governmental, in liaison with ISO, also take part in the work. ISO collaborates closely with the International Electrotechnical Commission (IEC) on all matters of electrotechnical standardization.

International Standards are drafted in accordance with the rules given in the ISO/IEC Directives, Part 2.

The main task of technical committees is to prepare International Standards. Draft International Standards adopted by the technical committees are circulated to the member bodies for voting. Publication as an International Standard requires approval by at least 75 % of the member bodies casting a vote.

Attention is drawn to the possibility that some of the elements of this document may be the subject of patent rights. ISO shall not be held responsible for identifying any or all such patent rights.

ISO 29282 was prepared by Technical Committee ISO/TC 204, *Intelligent transport systems*.

Introduction

This International Standard is part of a family of International Standards based on the communications access for land mobiles (CALM) concept. These International Standards specify a common architecture, network protocols and communication interface definitions for wireless communications using various access technologies including cellular 2nd generation, cellular 3rd generation, satellite, infra-red, 5 GHz microwave, 60 GHz millimetre-wave and mobile wireless broadband. These and other access technologies that can be incorporated are designed to provide broadcast, unicast and multicast communications between mobile stations, between mobile and fixed stations and between fixed stations in the intelligent transport systems (ITS) sector.

CALM standards are explicitly designed to enable quasi-continuous communications as well as communications of protracted duration between vehicles and service providers, and between vehicles.

The fundamental advantage of the CALM concept over traditional systems is the ability to support media independent handover (MIH), also referred to as heterogeneous or vertical handover, between the various media supported by CALM (e.g. cellular, microwave, mobile wireless broadband, infra-red, DSRC, and satellite). The CALM concept supports selection policies that include user preferences and media capabilities in making decisions as to which medium to use for a particular session, and when to hand over between media or between service providers on the same medium. These handover mechanisms are defined within the CALM architecture International Standard, ISO 21217, the CALM IPv6 networking protocols International Standard, ISO 21210, the CALM medium service access points International Standard, ISO 21218, and the CALM station management International Standard, ISO 24102. Handovers between access points using the same technology and service provider use mechanisms that are defined within the particular medium-specific CALM standard.

Satellite communications provide very broad coverage and are particularly useful in areas where there is no terrestrial wireless communications coverage, or when such systems are overloaded or have poor coverage. As satellite systems evolve, these systems may provide an alternative communication route in many situations. CALM station management will be able to ensure that the most appropriate network, of those available, will be used to improve ITS availability and reliability at the minimum cost. Example applications include urgent emergency messages such as eMessage or eCall, where an eCall over cellular radio may not be possible at the site of an accident, because of lack of cellular coverage.

Satellite communications systems will also be able to provide infill coverage where the deployment of the CALM M5 infrastructure set out in ISO 21215 is incomplete. Furthermore, satellite communications that support IPv6 broadcast mode will also support the geo-networking protocols that are currently being developed and standardized.

Additionally, satellite systems may be installed at ITS stations primarily because of the broadcast and paging services that they can deliver to support applications and the management of connections. The interface for broadcast satellite communications is defined in ISO 13183, using a protocol which is common to all of the broadcast media.

Intelligent transport systems — Communications access for land mobiles (CALM) — Satellite networks

1 Scope

This International Standard provides definitions and procedures for the establishment, maintenance and termination of an ITS (intelligent transport systems) communications session within a CALM (communication access for land mobiles) system environment using bi-directional satellite communications.

It defines the operation of the medium management adaptation entity (MMAE), which provides the management interface between a proprietary satellite communications medium and the “ITS station management”. This enables the “ITS station management” to know the status of the communications medium and control the interface without the need for applications at the ITS station to have any knowledge of the satellite communications interface. The procedures that the “ITS station management” expects to use are also explained.

NOTE 1 CALM links are required for quasi-continuous, prolonged and short-duration communications between vehicles and the roadside, between vehicles, and between mobile equipment and fixed infrastructure points, over medium and long ranges.

This International Standard defines how to connect and disconnect a communication session using satellite communication systems in the context of an application operated within the environment defined in ISO 21217. It supports peer-to-peer modes of communication. Support for broadcast satellite systems is defined in ISO 13183, which provides a common approach for all broadcast media. It supports satellite communications networks that are interconnected with the public network, as well as those which connect via the internet and those which provide a stand-alone capability.

NOTE 2 As there are multiple instantiations of satellite systems, most of which are not interoperable, there is the possibility of several simultaneous satellite sessions, each forming a separate CALM medium (although the differences may only be in software within the on-board equipment).

Wherever practicable, this International Standard has been developed by reference to suitable existing standards, adopted by selection. Application-specific upper layers are not included, but will be driven by application standards (which may not be technology-specific).

2 Conformance

In order to conform with this International Standard, communications using satellite communications protocols shall be established in full compliance with local telecommunications procedures and protocols and shall comply with the requirements of ISO 21210, ISO 21217, ISO 21218, ISO 24102 and ISO 25111. See Clause 3.

NOTE 1 ITU-T standards for satellites mostly relate to traditional telecommunications services such as voice, X21 and X25. In general, satellite services are delivered as closed proprietary solutions with standardized external interfaces, including ITU-T V.24 (EIA-232/RS-232), ITU-T V.11 (EIA-422/RS-422), ITU-T V.35 (EIA-449/RS-449), EIA-530/RS-530, ITU-T X-21 and EIA-423/RS-423. Such systems are not recommended for integration into ITS because of the need to provide adaptation to support IP communications.

NOTE 2 IPv6 systems are now being developed but have not yet been standardized. This interface International Standard has been developed to be consistent with these emerging new services.

3 Normative references

The following referenced documents are indispensable for the application of this document. For dated references, only the edition cited applies. For undated references, the latest edition of the referenced document (including any amendments) applies.

ISO 21210, *Intelligent transport systems — Communications access for land mobiles (CALM) — IPv6 Networking*¹⁾

ISO 21217, *Intelligent transport systems — Communications access for land mobiles (CALM) — Architecture*

ISO 21218, *Intelligent transport systems — Communications access for land mobiles (CALM) — Medium service access points*

ISO 24102, *Intelligent transport systems — Communications access for land mobiles (CALM) — Management*

ISO 25111, *Intelligent transport systems — Communications access for land mobiles (CALM) — General requirements for using public networks*

4 Terms and definitions

For the purposes of this document the terms and definitions given in ISO 21217 and the following apply.

4.1

CALM application session

association of two or more parties for the provision of CALM application service, which, until its termination, can involve more than one communication session in order to exchange information (i.e. are involved in a transaction)

NOTE 1 A CALM application session is not possible unless a communication session (4.2) is first established.

NOTE 2 An application session will normally involve multiple bidirectional transfers of data, but can be a unidirectional transfer of data.

[ISO 25111]

4.2

communication session

association of two or more wireless communication devices between which a functional wireless communication link is available for mutual exchange of data/information

NOTE Application sessions (see 4.1) engage in and complete transactions using communication sessions.

[ISO 25111]

5 Abbreviated terms

CALM	communications access for land mobiles
CI	communication interface
CMPL	communication module protocol layer
DSRC	dedicated short range communication
ETSI	European Telecommunications Standards Institute
FSS	fixed satellite services
GEO	geostationary earth orbit
GNSS	global satellite navigation system
GSM	global system for mobile communications
IN-SAP	interface service access point (formerly “C-SAP”)
IPv4	internet protocol version 4

1) To be published.

IPv6	internet protocol version 6
ITS	intelligent transport systems
LEO	low (altitude) earth orbit
MAC	medium access control
MEO	medium (altitude) earth orbit
MI-SAP	management service access point (formerly “M-SAP”)
MMAE	medium management adaptation entity
MSS	mobile satellite services
MSS/ATC	mobile satellite services with ancillary terrestrial components
PCS	personal communications service
SAP	service access point
SAR	search and rescue

6 Background

6.1 Proprietary connectivity protocols

Satellite communications systems are implemented in a variety of ways, delivering different characteristics. It is useful to have an overview of these implementations and their characteristics because these will affect the way that CALM applications will use these systems. This will therefore affect the design of CALM systems that use satellite communications.

Geostationary earth orbit (GEO) satellites orbit over the equator at the same rotation rate as the earth, so appear to be stationary above the equator (35,786 km above the earth’s surface). A set of satellites at fixed positions ensure that all longitudes can be covered; however, coverage at higher latitudes is limited, with significant obstruction possible in urban areas and rural areas with obstructions such as trees.

Non-GEO satellites may be at low (LEO) or medium height (MEO) above the earth. Non-GEO satellites have orbits offset to the equator, giving much better coverage at higher latitudes. Continuous coverage and availability are possible if there are sufficient orbits and satellites. Store and forward techniques need to be used if there are insufficient satellites to give continuous availability. MEO satellites operate with an orbit time of between 2 h and 12 h. The advantages of the lower and faster orbit is that the satellite is closer to the ground and therefore has less path loss, and potentially a smaller coverage footprint, which allows more frequency reuse and therefore higher capacity for a given spectrum allocation. However, these systems do require more satellites to give the required availability and introduce an additional overhead in the management of the handover of sessions from one satellite to the next. Note that this complexity is handled in the receiver and is not visible to CALM systems, except that any impact on instantaneous availability would be reported to the “ITS station management” using the interface and protocols defined in ISO 21218.

Additionally, highly elliptical orbits offer the advantage that the satellites spend a significant proportion of their time at high altitude at a point which can be set to be above the main area where coverage is required. Coverage of a large area (or continent) can be achieved by several satellites spaced in the orbit such that the traffic is passed from one satellite to the next.

Satellites may be optimized for fixed or mobile services. Fixed systems typically have a larger antenna with higher gain, which allows a higher bandwidth.

Some satellite system service providers also operate ancillary terrestrial components, otherwise known as complimentary ground components, where the satellite transceiver will switch automatically to use a terrestrial wireless service typically provided by a third party operator (e.g. GSM/PCS). This has some similarity to the

heterogeneous handover that is provided by CALM, but is implemented as a proprietary solution that typically provides a single alternative medium, via a commercial arrangement provided by the satellite service operator.

Commercial satellite services all rely upon proprietary protocols to handle data communications within their system. Interworking between systems is not supported. Only the interface between the satellite transceiver and the CALM station is standardized.

The following are examples of satellite telecommunications systems to which this International Standard is applicable²⁾.

- a) MSS (GEO):
 - 1) Aces;
 - 2) Inmarsat;
 - 3) Thuraya;
 - 4) Solaris S-Band;
 - 5) Inmarsat S-Band.
- b) MSS (non-GEO):
 - 1) Galileo (SAR);
 - 2) Globalstar;
 - 3) Iridium IS.
- c) Store and forward (non-GEO):
 - 1) Argos;
 - 2) ORBCOM.
- d) MSS/ATC:
 - 1) ICO GLOBAL;
 - 2) Mobile Satellite Ventures (MSV);
 - 3) Terrestar Networks.
- e) FSS:
 - 1) Eutelsat;
 - 2) HYLAS;
 - 3) IP STAR;
 - 4) SES Astra;
 - 5) Telesat/Wildblue.

NOTE There are many satellites that provide broadcast services. Typically, these are primarily for entertainment and carry either video or audio or, additionally, GNSS. The interface to these systems is the subject of ISO 13183.

2) This information is given for the convenience of users of this document and does not constitute an endorsement by ISO of these products.

6.2 Internet connectivity

Satellite systems that support IPv4 and IPv6 are becoming available.

IPv6 communications can be supported either by transmitting IPv6 packets encapsulated into IPv4 packets (when IPv4 support is provided) or natively. The satellite link will be seen as an *IPv6 egress interface* from the point of view of the IPv6 networking layer specified in ISO 21210.

Satellite systems implementing IPv6 broadcast mode will be able to support geo-networking protocols that are being defined within ETSI as an extension to the IPv6 networking defined in ISO 21210.

For satellite telecommunications systems that support internet connectivity, conformance shall be as determined in the system specifications.

NOTE At some point in the future, a conformance standard for the generic aspects may be developed, but at present this is beyond the scope of this International Standard.

7 Requirements

7.1 General

The efficient connection of a satellite communications system into a CALM station requires compliance with a number of related International Standards.

The overall CALM architecture set out in ISO 21217 defines how the individual standards operate together to deliver the total functionality. An abstraction of the total architecture is shown in Figure 1, which shows only the modules that the satellite communications system has direct interaction with, and identifies the corresponding International Standards.

Requirements from each of these International Standards are considered in the following subclauses, together with consideration of the need to interface to a diverse range of proprietary satellite systems.

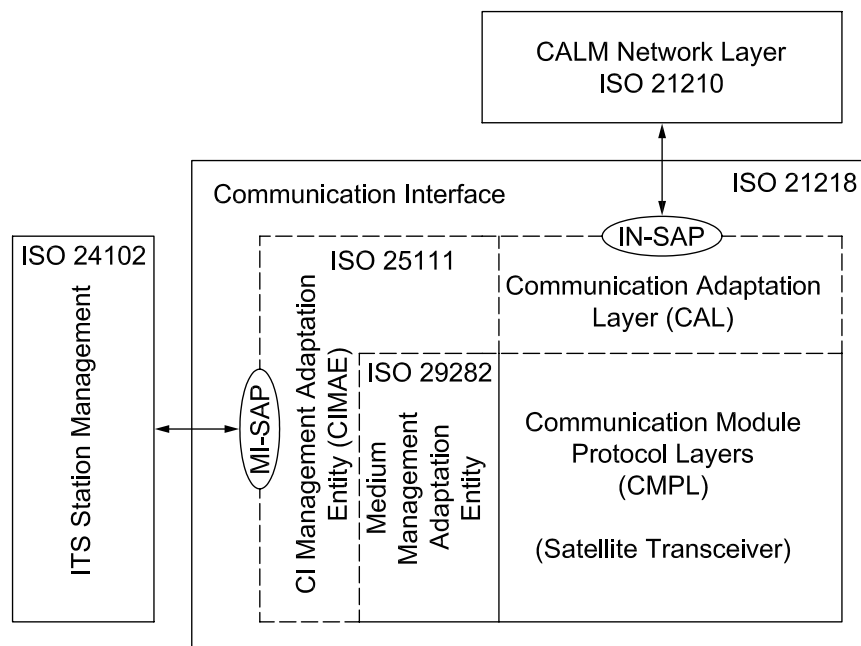

Figure 1 — Interdependency in CALM standards (adapted from ISO 21218:2008, Figure 1)

7.2 Adoption of satellite standards and internationally adopted practices

Equipment and systems complying with this International Standard shall operate within the environment, regulations and parameters defined for satellite systems in internationally adopted practices and within the limits and parameters defined in regional and national regulations.

NOTE The frequency spectrum allocation for radio communications, including satellite communications, is given in the Radio Regulations, published by the International Telecommunication Union (ITU).

7.3 CALM architecture and application grouping

Equipment and systems complying with this International Standard shall operate in the environment of, and within the parameters defined in, ISO 21217.

Applications may be grouped according to common communications requirements:

- a) bi-directional communication link (peer-to-peer and client-server transactions);
- b) uplink only systems providing a one-way communication link — from vehicle to service centre (e.g. probe data, emergency beacon alarms);
- c) downlink only systems:
 - 1) broadcast applications (e.g. map updates, road-use charging fee tables, and traffic information);
 - 2) broadcast communication of management information (e.g. paging of the vehicle);
 - 3) broadcast with a return link (e.g. for message acknowledgement) — the return link may use a non-satellite return path if this is not provided by the satellite system.

Only the application groups a) and b) above are supported by this International Standard. The broadcast mode communications identified in c) are covered in ISO 13183.

7.4 CALM networking protocols

Equipment and systems complying with this International Standard shall operate in the environment of, and within the parameters defined in, ISO 21210.

The satellite link shall be seen as an *IPv6 egress interface* from the point of view of the IPv6 networking layer and shall thus be configured with an IPv6 address as specified in ISO 21210.

Satellite communications shall support the emerging geo-networking protocols.

NOTE The specification of IPv6 support in satellite networks is outside the scope of this International Standard.

7.5 CALM medium service access points

Equipment and systems complying with this International Standard shall operate in the environment of, and within the parameters defined in, ISO 21218.

This interface is used for control and to provide information on the status of the relevant communications medium. Satellite coverage varies with the location of the user and, most importantly, the location of the satellite. There may be particular moments in time when the satellite link may not be available.

7.6 CALM “ITS station management”

Equipment and systems complying with this International Standard shall operate in the environment of, and within the parameters defined in, ISO 24102.

7.7 CALM using public wireless networks

Equipment and systems complying with this International Standard shall operate in the environment of, and within the parameters defined in, ISO 25111.

NOTE The following subclauses reference provisions of ISO 25111 which define the particular context and specification.

7.8 Establishment and termination of medium specific sessions

Three classes of communication session are identified below. Different satellite communications systems operate in each of these modes. The choice of mode is dictated by the types of service that the system is designed to support and by the commercial arrangements. Each of these modes will need to be supported when implementing this International Standard.

7.8.1 Establishment and termination of “continuous” session

Equipment and systems complying with this International Standard shall utilize procedures determined in accordance with ISO 25111:2009, 6.1.4.

7.8.2 Establishment and termination of “time controlled” session

Equipment and systems complying with this International Standard shall utilize procedures determined in accordance with ISO 25111:2009, 6.1.5.

7.8.3 Establishment and termination of “user controlled” session

Equipment and systems complying with this International Standard shall utilize procedures determined in accordance with ISO 25111:2009, 6.1.3 and 6.1.6.

7.9 Interface medium management

Interface medium management shall be conducted in accordance with ISO 25111:2009, 6.5. to 6.7.

8 Medium access control (MAC)

8.1 Conformance

The MAC shall be conducted in accordance with ISO 25111:2009, Clause 7.

8.2 CALM satellite communications MMAE service primitives

The CALM system needs to be able to control and monitor the communications systems that are available. A common set of service primitives have been defined which the “ITS station management” will use to interact with each communications medium. The CALM-compliant satellite communications medium management adaptation entity (MMAE) shall support the following service primitives.

8.2.1 MMAE-SetParam.request

The command used to set a parameter.

```
MMAE-SetParam.request
    int interfaceld,
    uchar paramNumber,    // 128 -
    uchar paramValue;    // 1: connect, 2: disconnect
```

8.2.2 MMAE-SetParam.confirm

Confirmation that the instruction has been received and also whether it has been possible to perform the request.

```
MMAE-SetParam.confirm
    int interfaceld, uchar paramNumber, uchar paramValue, uchar result
```

8.2.3 MMAE-GetParam.request

```
MMAE-GetParam.request
    int interfaceld, uchar paramNumber
```

8.2.4 MMAE-GetParam.confirm

```
MMAE-GetParam.confirm
    int interfaceld, uchar paramNumber, uchar ifStatus, struct ifChar, uchar result
```

8.2.5 MMAE-Notify.indication

```
MMAE-Notify.indication
    int interfaceld
    uchar status;    // 1: disconnected, 2: connected
```

8.3 Satellite communication MMAE

The procedures for session initiation shall be in accordance with 7.8.

In order to establish a session, the CALM satellite CI MMAE shall perform the following procedure.

8.3.1 MMAE-SetParam.request=1

On receipt of *MMAE-SetParam.request* (int interfaceld, uchar paramNumber = 128, uchar paramValue = 1) service, the satellite communications MMAE on the mobile station side shall attempt to connect to the satellite communications system.

8.3.2 MMAE-GetParam.request=2

On receipt of *MMAE-GetParam.request* (int interfaceId, uchar paramNumber = 2), the satellite MMAE on the mobile station side shall obtain information on the interface characteristics and current status of the satellite system MAC at the mobile station.

MMAE-GetParam.req

int interfaceId;

uchar paramNumber

1: Request for interface status

2: Request for interface characteristics

8.3.3 MMAE-GetParam.confirm

Once the parameter value is received, the satellite MMAE shall send the *MMAE-GetParam.confirm* primitive to the "ITS station management".

MMAE-GetParam.confirm

int interfaceId;

uchar paramNumber

uchar ifStatus

valid if ParameterNumber is 1 (1: Connected, 2: Disconnected)

valid if ParameterNumber is 2 (1: Connected, 2: Disconnected)

int DataRate, int Cost, uchar ServiceType, uchar Security

uchar result

NOTE "Connected" implies the creation/maintenance of a session, while "Disconnected" implies that there is no longer a current operational session in progress.

8.3.4 Result

The parameter "result" in *MMAE-GetParam.confirm* represents the processing result of the request service:

1: OK successful reply

2: Error no such media

3: Unknown error

8.3.5 Further procedures

No special/additional procedures for satellite communications have been defined in the present edition of this International Standard.

NOTE Further analysis may reveal additional procedures that are needed, which could be added in a future edition.

8.4 CALM session connection

8.4.1 Session connection sequence

The procedures for session initiation shall be in accordance with 7.8.

In order to establish a session, the CALM satellite CI MMAE shall perform the following procedure, in the sequence given.

On receipt of *MMAE-SetParam.request* (int interfaceld, uchar paramNumber = 128, uchar paramValue = 1) service, the satellite MMAE on the mobile station side shall attempt to connect to the satellite infrastructure.

Subsequently, the CALM satellite MMAE shall send the satellite *MMAE-SetParam.confirm* (ok) primitive to the "ITS station management".

The parameter "result" in *MMAE-SetParam.confirm* represents the processing result of the connection request service and shall be as follows:

- 1: OK the satellite CI MMAE shall attempt to connect
- 2: Fail try later
- 3: System error

8.4.2 Successful CALM session establishment

Once the satellite connection is established, the satellite CI MMAE shall notify the "ITS station management" of the changed status of the medium using the *MMAE-Notify.indication* service.

8.5 CALM session disconnection

On receipt of the *MMAE-SetParam.request* (int interfaceld, uchar paramNumber = 128, uchar paramValue = 2) service, the satellite CI MMAE on the mobile station side shall try to disconnect from the satellite system. The satellite CI MMAE shall then send the *MMAE-SetParam.confirm* primitive to the "ITS station management".

The parameter "result" in *MMAE-SetParam.confirm* represents the processing result of the connection request service:

- 1: OK the satellite CI MMAE has completed disconnection
- 2: Fail try later
- 3: System error

On receipt of the *MMAE-SetParam.request* (int interfaceld, uchar paramNumber = 128, uchar paramValue = 1) service, the satellite MMAE on the mobile station side shall attempt to connect to the satellite base station.

8.6 Change of satellite communications connection state

If the satellite communications connection state changes during the session, the satellite communications MMAE in the mobile station shall immediately notify this to the "ITS station management" using the *MMAE-Notify.indication* primitive.

8.7 Retrieval of medium status

The “ITS station management” can check the status of the specific medium. On receipt of the *MMAE-GetParam.request* (int interfaceld, uchar paramNumber), the satellite MMAE on the mobile station side shall inquire as to the status of the medium of the mobile station.

8.7.1 MMAE GetParam.req

MMAE-GetParam.req

int interfaceld;

uchar paramNumber

1: Request for interface status

2: Request for interface characteristics

8.7.2 MMAE GetParam.confirm

MMAE-GetParam.confirm

int interfaceld;

uchar paramNumber

uchar ifStatus

struct ifChar

uchar result

The parameter “result” in *MMAE-GetParam.confirm* represents the processing result of request service:

1: OK successful reply

2: Error no such media

3: Unknown error

8.8 Satellite communications specific connection aspects

The procedures for session initiation shall be in accordance with 7.8.

Beyond the CALM MMAE requirements defined above, it is necessary to follow the connection establishment procedures defined in satellite communications; the procedures defined in the relevant satellite communications protocols shall additionally be followed.

NOTE No additional requirements had been identified at the time of publication of this International Standard.

Once the satellite communications connection procedure is successfully completed, the medium connection is established.

8.9 Satellite communications session disconnection

In accordance with the relevant satellite communications standard, the satellite communications connection shall be closed

- a) by disconnection procedures for the specific satellite communication service,
- b) as a result of the completion of a CALM session, in accordance with 8.5.

Where the disconnection is as a result of a discontinuity in the satellite service, or an action by the satellite service operator, completion of the disconnection process shall be reported to the “ITS station management” using the *MMAE-Notify.indication* service described in 8.2.5.

9 Test and conformance requirements

Test and conformance requirements shall be in accordance with ISO 25111.

10 Declaration of patents and intellectual property

Patents and intellectual property used in CALM satellite communications may be obtained by reference to the proprietary connectivity protocols given in 6.1, and their related standards.

Information can be found in the following International Standards:

- for any patents and intellectual property associated with CALM architecture, see ISO 21217;
- for any patents and intellectual property associated with CALM networking protocols, see ISO 21210;
- any patents and intellectual property associated with CALM medium service access protocols can be found in the references included in ISO 21218.

Bibliography

- [1] ISO 13183, *Intelligent transport systems — Communications access for land mobiles (CALM) — Using broadcast communications*³⁾
- [2] ISO 21215, *Intelligent transport systems — Communications access for land mobiles (CALM) — M5*

3) To be published.

British Standards Institution (BSI)

BSI is the national body responsible for preparing British Standards and other standards-related publications, information and services.

BSI is incorporated by Royal Charter. British Standards and other standardization products are published by BSI Standards Limited.

About us

We bring together business, industry, government, consumers, innovators and others to shape their combined experience and expertise into standards-based solutions.

The knowledge embodied in our standards has been carefully assembled in a dependable format and refined through our open consultation process. Organizations of all sizes and across all sectors choose standards to help them achieve their goals.

Information on standards

We can provide you with the knowledge that your organization needs to succeed. Find out more about British Standards by visiting our website at bsigroup.com/standards or contacting our Customer Services team or Knowledge Centre.

Buying standards

You can buy and download PDF versions of BSI publications, including British and adopted European and international standards, through our website at bsigroup.com/shop, where hard copies can also be purchased.

If you need international and foreign standards from other Standards Development Organizations, hard copies can be ordered from our Customer Services team.

Subscriptions

Our range of subscription services are designed to make using standards easier for you. For further information on our subscription products go to bsigroup.com/subscriptions.

With **British Standards Online (BSOL)** you'll have instant access to over 55,000 British and adopted European and international standards from your desktop. It's available 24/7 and is refreshed daily so you'll always be up to date.

You can keep in touch with standards developments and receive substantial discounts on the purchase price of standards, both in single copy and subscription format, by becoming a **BSI Subscribing Member**.

PLUS is an updating service exclusive to BSI Subscribing Members. You will automatically receive the latest hard copy of your standards when they're revised or replaced.

To find out more about becoming a BSI Subscribing Member and the benefits of membership, please visit bsigroup.com/shop.

With a **Multi-User Network Licence (MUNL)** you are able to host standards publications on your intranet. Licences can cover as few or as many users as you wish. With updates supplied as soon as they're available, you can be sure your documentation is current. For further information, email bsmusales@bsigroup.com.

BSI Group Headquarters

389 Chiswick High Road London W4 4AL UK

Revisions

Our British Standards and other publications are updated by amendment or revision.

We continually improve the quality of our products and services to benefit your business. If you find an inaccuracy or ambiguity within a British Standard or other BSI publication please inform the Knowledge Centre.

Copyright

All the data, software and documentation set out in all British Standards and other BSI publications are the property of and copyrighted by BSI, or some person or entity that owns copyright in the information used (such as the international standardization bodies) and has formally licensed such information to BSI for commercial publication and use. Except as permitted under the Copyright, Designs and Patents Act 1988 no extract may be reproduced, stored in a retrieval system or transmitted in any form or by any means – electronic, photocopying, recording or otherwise – without prior written permission from BSI. Details and advice can be obtained from the Copyright & Licensing Department.

Useful Contacts:

Customer Services

Tel: +44 845 086 9001

Email (orders): orders@bsigroup.com

Email (enquiries): cservices@bsigroup.com

Subscriptions

Tel: +44 845 086 9001

Email: subscriptions@bsigroup.com

Knowledge Centre

Tel: +44 20 8996 7004

Email: knowledgecentre@bsigroup.com

Copyright & Licensing

Tel: +44 20 8996 7070

Email: copyright@bsigroup.com



...making excellence a habit.™