

BS ISO 28741:2013



BSI Standards Publication

# Road vehicles — Spark-plugs and their cylinder head housings — Basic characteristics and dimensions

**bsi.**

...making excellence a habit.™

**National foreword**

This British Standard is the UK implementation of ISO 28741:2013. It supersedes BS ISO 28741:2009 which is withdrawn.

The UK participation in its preparation was entrusted to Technical Committee MCE/22, Engines for road vehicles.

A list of organizations represented on this committee can be obtained on request to its secretary.

This publication does not purport to include all the necessary provisions of a contract. Users are responsible for its correct application.

© The British Standards Institution 2013. Published by BSI Standards Limited 2013

ISBN 978 0 580 73389 5

ICS 43.060.50

**Compliance with a British Standard cannot confer immunity from legal obligations.**

This British Standard was published under the authority of the Standards Policy and Strategy Committee on 30 November 2013.

**Amendments issued since publication**

Date	Text affected
------	---------------

---

INTERNATIONAL  
STANDARD

**ISO**  
**28741**

Second edition  
2013-11-15

---

---

**Road vehicles — Spark-plugs and  
their cylinder head housings — Basic  
characteristics and dimensions**

*Véhicules routiers — Bougies d'allumage et leur logement dans la  
culasse — Caractéristiques élémentaires et dimensions*



Reference number  
ISO 28741:2013(E)

© ISO 2013



**COPYRIGHT PROTECTED DOCUMENT**

© ISO 2013

All rights reserved. Unless otherwise specified, no part of this publication may be reproduced or utilized otherwise in any form or by any means, electronic or mechanical, including photocopying, or posting on the internet or an intranet, without prior written permission. Permission can be requested from either ISO at the address below or ISO's member body in the country of the requester.

ISO copyright office  
Case postale 56 • CH-1211 Geneva 20  
Tel. + 41 22 749 01 11  
Fax + 41 22 749 09 47  
E-mail [copyright@iso.org](mailto:copyright@iso.org)  
Web [www.iso.org](http://www.iso.org)

Published in Switzerland

# Contents

	Page
<b>Foreword</b> .....	<b>iv</b>
<b>Introduction</b> .....	<b>v</b>
<b>1 Scope</b> .....	<b>1</b>
<b>2 Normative references</b> .....	<b>1</b>
<b>3 Terms and definitions</b> .....	<b>1</b>
<b>4 Terminals</b> .....	<b>3</b>
4.1 Solid post terminal dimensions.....	3
4.2 Threaded terminal dimensions.....	4
<b>5 Dimensions, threads, and related items</b> .....	<b>4</b>
5.1 Spark-plug reach.....	4
5.2 Gasket.....	5
5.3 Threads, limiting dimensions, and tolerances.....	5
<b>6 Other dimensions of spark-plugs and their cylinder head housings</b> .....	<b>6</b>
<b>7 Installation tightening torque</b> .....	<b>6</b>
<b>8 Spark-plug dimensions</b> .....	<b>7</b>
8.1 Spark-plugs with flat seating.....	7
8.2 Spark-plugs with conical seating.....	14
<b>9 Cylinder head housings</b> .....	<b>19</b>
9.1 Cylinder head housing for spark-plugs with flat seating.....	19
9.2 Cylinder head housing for spark-plugs with conical seating.....	21
<b>Annex A (normative) Spark-plugs with half thread and their cylinder head housings</b> .....	<b>22</b>
<b>Annex B (informative) Optional terminals for compact spark-plugs</b> .....	<b>24</b>
<b>Annex C (informative) Optional combination cylinder head housing for spark-plugs with conical or flat seating</b> .....	<b>26</b>
<b>Bibliography</b> .....	<b>27</b>

## Foreword

ISO (the International Organization for Standardization) is a worldwide federation of national standards bodies (ISO member bodies). The work of preparing International Standards is normally carried out through ISO technical committees. Each member body interested in a subject for which a technical committee has been established has the right to be represented on that committee. International organizations, governmental and non-governmental, in liaison with ISO, also take part in the work. ISO collaborates closely with the International Electrotechnical Commission (IEC) on all matters of electrotechnical standardization.

The procedures used to develop this document and those intended for its further maintenance are described in the ISO/IEC Directives, Part 1. In particular the different approval criteria needed for the different types of ISO documents should be noted. This document was drafted in accordance with the editorial rules of the ISO/IEC Directives, Part 2 (see [www.iso.org/directives](http://www.iso.org/directives)).

Attention is drawn to the possibility that some of the elements of this document may be the subject of patent rights. ISO shall not be held responsible for identifying any or all such patent rights. Details of any patent rights identified during the development of the document will be in the Introduction and/or on the ISO list of patent declarations received (see [www.iso.org/patents](http://www.iso.org/patents)).

Any trade name used in this document is information given for the convenience of users and does not constitute an endorsement.

For an explanation on the meaning of ISO specific terms and expressions related to conformity assessment, as well as information about ISO's adherence to the WTO principles in the Technical Barriers to Trade (TBT) see the following URL: [Foreword - Supplementary information](#)

The committee responsible for this document is ISO/TC 22, *Road vehicles*, Subcommittee SC 1, *Ignition equipment*.

This second edition cancels and replaces the first edition (ISO 28741:2009), which has been technically revised. It also incorporates the Technical Corrigendum ISO 28741:2009/Cor1:2009.

## Introduction

The purpose of this International Standard is to provide a compact and concise specification on spark-plugs and their cylinder head housings, which replaces the large number of existing individual International Standards on each type of spark-plug.

It is intended to specify the main properties, the design requirements, and the dimensions of most of the existing types of spark-plugs and their cylinder head housings. In this way, the user can work with one comprehensive International Standard valid for most types of spark-plugs, instead of a number of International Standards, each of which is specified for one type only.

The testing of spark-plugs is covered in ISO 11565.





# Road vehicles — Spark-plugs and their cylinder head housings — Basic characteristics and dimensions

## 1 Scope

This International Standard specifies the main properties and dimensions of spark-plugs, including the terminals and the dimensions of their cylinder head housings, for use with spark-ignition engines.

This International Standard does not cover screened and waterproof spark-plugs (see ISO 3412, ISO 3895, and ISO 3896).

## 2 Normative references

The following documents, in whole or in part, are normatively referenced in this document and are indispensable for its application. For dated references, only the edition cited applies. For undated references, the latest edition of the referenced document (including any amendments) applies.

ISO 68-1, *ISO general purpose screw threads — Basic profile — Part 1: Metric screw threads*

ISO 261, *ISO general purpose metric screw threads — General plan*

ISO 965-1, *ISO general-purpose metric screw threads — Tolerances — Part 1: Principles and basic data*

ISO 965-3, *ISO general purpose metric screw threads — Tolerances — Part 3: Deviations for constructional screw threads*

ISO 4095, *Aerospace — Bihexagonal drives — Wrenching configuration — Metric series*

ISO 6518-1, *Road vehicles — Ignition systems — Part 1: Vocabulary*

## 3 Terms and definitions

For the purposes of this document, the terms and definitions given in ISO 6518-1 and the following apply.

### 3.1

#### **installed height**

*l*

distance from the contact point of the cylinder head to the top of the spark-plug terminal, including the compressed gasket thickness with the spark-plug installed at the specified installation torque

Note 1 to entry: For conical seating, the contact point is defined from the gauge point of the seat.

### 3.2

#### **spark-plug thread size**

nominal size of the spark-plug thread used to interface between the spark-plug and the cylinder head thread

Note 1 to entry: These are standard metric threads, with the exception of the M14 × 1,25 thread.

### 3.3

#### **hexagon/bi-hexagon**

feature of the spark-plug shell that is used to install the spark-plug into the cylinder head, interfacing with the installation socket while the spark-plug is installed into the cylinder head

Note 1 to entry: A bi-hexagon is a 12-point installation feature, which requires that a 12-point socket wrench be used to install the spark-plug.

### 3.4 conical seating

conical section of the spark-plug shell on some spark-plug types, which is used for the seal interface between the spark-plug and the cylinder head

Note 1 to entry: There is typically no gasket used between the conical mating surfaces.

### 3.5 flat seating

flat surface of some spark-plug types which is perpendicular to the spark-plug axis and is used for the seal interface between the spark-plug and the cylinder head

Note 1 to entry: This seal typically uses a gasket between the flat seat of the spark-plug and the mating flat surface of the cylinder head.

### 3.6 insulator diameter

*e*

nominal diameter of the insulator in a defined region of the insulator between the top of the shell and the terminal of the spark-plug, which interfaces with a corresponding region of the high-voltage boot of the ignition lead or ignition coil

Note 1 to entry: The fit is the key to suppression of high-voltage leakage around the spark-plug insulator (flashover).

### 3.7 high-voltage terminal

part of the spark-plug that is used as the contact point between the high-voltage ignition source and the spark-plug

Note 1 to entry: The connection between the high-voltage ignition source and the spark-plug terminal can be made with a threaded fastener, with a snap clip that interfaces with the solid terminal or by spring-loaded mechanical contact.

### 3.8 installation tightening torque

rotational force applied to the spark-plug hexagon to ensure proper seating and sealing of the spark-plug to the cylinder head

Note 1 to entry: The value of the correct installation tightening torque can vary from conditions that affect the friction between the spark-plug threads and the cylinder head threads. These include cylinder head material, spark-plug shell plating, thread lubrication, and contamination from combustion deposits. It is advisable to ensure that spark-plugs are not over-torqued during installation, as this can damage spark-plug integrity and can result in engine damage. Spark-plugs with smaller thread sizes require a lower installation tightening torque.

### 3.9 spark-plug reach

*a*

distance from the spark-plug seating surface (flat seat) or from the gauge diameter (conical seat) to the point on the shell designed to be aligned with the combustion chamber surface on the cylinder head with the spark-plug properly installed

Note 1 to entry: It is advisable to design the spark-plug reach and the cylinder head housing in such a way that they match, so as to ensure correct fit of the spark-plug into the combustion chamber.

### 3.10 spark-plug projection

*b-a*

distance that any part of the spark-plug projects past the spark-plug reach into the combustion chamber

Note 1 to entry: It is important to consider this dimension for possible interference with the engine piston at top dead centre.

## 4 Terminals

### 4.1 Solid post terminal dimensions

The dimensions of solid post terminals shall be in accordance with [Figures 1](#) and [2](#).

Nuts for use with threaded terminals shall have the same external dimensions as those of the solid post terminal, and shall have internal threads to 6H tolerance prior to assembly on the threaded terminals.

Dimensions in millimetres

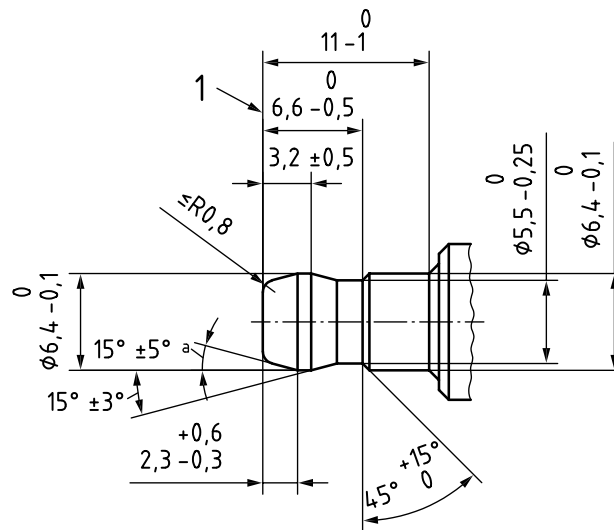

#### Key

- 1 reference plane
- a For existing products, values between  $7^\circ$  and  $30^\circ$  are allowed.

**Figure 1 — Solid post terminal**

The measurement of the minimum diameter of 6,3 mm shall be taken at any or all points around the post circumference. A ring gauge shall be used for measuring the maximum diameter of 6,4 mm.

Dimensions in millimetres

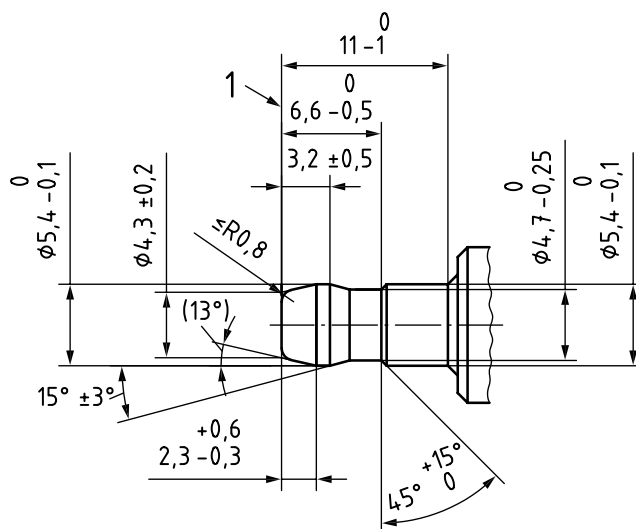

**Key**  
1 reference plane

**Figure 2 — Solid post terminal for M10 × 1 bi-hex 12 mm spark-plugs**

The measurement of the minimum diameter of 5,3 mm shall be taken at any or all points around the post circumference. A ring gauge shall be used for measuring the maximum diameter of 5,4 mm.

## 4.2 Threaded terminal dimensions

The dimensions of threaded terminals shall be in accordance with [Figure 3](#).

Dimensions in millimetres

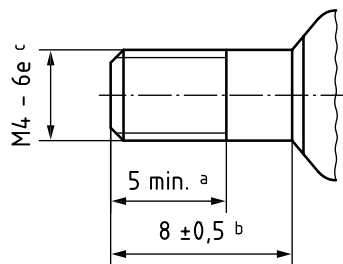

**Key**  
a Length of usable thread.  
b Cylindrical part.  
c Depending on manufacturing process, tolerance class 7e is acceptable on finished product.

**Figure 3 — Threaded terminal**

## 5 Dimensions, threads, and related items

### 5.1 Spark-plug reach

The spark-plug reach shall be in accordance with [Table 5](#) or [7](#) (see also [Figures 4](#) to [15](#)).

The following basic types of spark-plug reach are defined:

- Short: S
- Medium: M
- Long: L
- Extended long: EL
- Extra long: XL
- Extended extra long: EXL

## 5.2 Gasket

When unused spark-plugs with flat seating have been tightened once with a torque, as specified in [Clause 7](#) and [Table 3](#), on threads that are clean, smooth, and dry, the gasket thickness shall be as specified in [Table 3](#). Non-captive gaskets may be used in special cases.

## 5.3 Threads, limiting dimensions, and tolerances

The threads of spark-plugs and the corresponding tapped holes in the cylinder heads shall conform to ISO 68-1, ISO 261, ISO 965-1, and ISO 965-3. Their limiting dimensions, minor diameters, basic profiles, and initial clearances are specified in [Tables 1](#) and [2](#), respectively.

**Table 1 — Limiting dimensions**

Dimensions in millimetres

Thread size	Tolerance class	Dimension	Major diameter		Pitch diameter		Minor diameter	
			max.	min.	max.	min.	max.	min.
M18 × 1,5	6e	Plug thread (on finished plug)	17,933	17,697	16,959	16,819	16,092	15,845 <sup>a</sup>
	6H	Tapped hole in the cylinder head	not specified	18,000	17,216	17,026	16,676	16,376
M14 × 1,25	6e	Plug thread (on finished plug)	13,937	13,725	13,125	12,993	12,404	12,181 <sup>b</sup>
	6H	Tapped hole in the cylinder head	not specified	14,000	13,368	13,188	12,912	12,647
M12 × 1,25	6e	Plug thread (on finished plug)	11,937	11,725	11,125	10,993	10,404	10,181 <sup>b</sup>
	6H	Tapped hole in the cylinder head	not specified	12,000	11,368	11,188	10,912	10,647
M10 × 1	6g	Plug thread (on finished plug)	9,974	9,794	9,324	9,212	8,747	8,563 <sup>c</sup>
	6H	Tapped hole in the cylinder head	not specified	10,000	9,500	9,350	9,153	8,917

<sup>a</sup> With a root radius  $\geq 0,150$  mm (0,1 *P*).

<sup>b</sup> With a root radius  $\geq 0,125$  mm (0,1 *P*).

<sup>c</sup> With a root radius  $\geq 0,1$  mm (0,1 *P*).

**Table 2 — Minor diameters, basic profiles, and initial clearances for threads used**

Dimensions in millimetres

Thread size	Minor diameter <sup>a</sup> $d_{3\max}$	Fundamental deviation <sup>b</sup> $es$
M18 × 1,5 – 6e	$d_{3\max} = (16,376 - 0,067 - 0,217) = 16,092$	0,067
M14 × 1,25 – 6e	$d_{3\max} = (12,647 - 0,063 - 0,180) = 12,404$	0,063
M12 × 1,25 – 6e	$d_{3\max} = (10,647 - 0,063 - 0,180) = 10,404$	0,063
M10 × 1 – 6g	$d_{3\max} = (8,917 - 0,026 - 0,144) = 8,747$	0,026

<sup>a</sup> The maximum value of the minor diameter,  $d_{3\max}$ , is calculated according to ISO 965-1:1998, Clause 11 with a truncation of H/6, in accordance with the following equation:  $d_{3\max} = D_1 - es - 2(H/4 - H/6)$ .

<sup>b</sup> The fundamental deviation (term used in ISO 965-1 instead of “initial clearance”),  $es$ , between the pitch diameters of the thread and of the tapped hole is intended to prevent the possibility of seizure, as a result of combustion deposits on the bare threads, when removing the spark-plugs. This clearance is also intended to enable spark-plugs with threads in accordance with this International Standard to be fitted in existing tapped holes.

## 6 Other dimensions of spark-plugs and their cylinder head housings

The other dimensions of spark-plugs and their cylinder head housings shall be as indicated in [Figures 4](#) to [17](#), [Tables 5](#) to [10](#), and [Figures A.1](#), [A.2](#), and [C.1](#).

The installed height,  $l$ , shall be measured when the spark-plug has been tightened, as specified in [Table 3](#) or [4](#).

The contour of the insulator is optional; however, between the reference planes defined by the dimensions  $c$  and  $d$ , its diameter shall be  $e$ , as specified in [Table 5](#) or [7](#).

The non-ribbed insulator design is preferred because it provides superior protection to dielectric tracking between the spark-plug insulator and the cover.

The lengths of the cylinder head housing,  $Z$  and  $Z'$  (see [Figures 16](#), [17](#), [A.2](#), and [C.1](#)), shall be sufficient to ensure that the end of the spark-plug thread does not project into the combustion chamber at any point when the spark-plug is tightened to its maximum specified torque.

Alternative cylinder head housing with a combination of conical and flat seating is possible (see [Annex C](#)).

## 7 Installation tightening torque

The installation tightening torque values in [Tables 3](#) and [4](#) apply to new spark-plugs without lubricant on the threads (production-related remains of lubricants are permitted). If threads are lubricated, the torque value in the table shall be reduced by approximately one-third to avoid overstressing.

Engine manufacturers may specify a different torque for the first spark-plug installation.

The torque values for measuring the gasket thickness and the installed height are also given in [Table 3](#).

**Table 3 — Tightening torque for spark-plugs with flat seating**

Thread size <i>n</i>	Cast-iron seating Torque Nm	Aluminum alloy seating Torque Nm	Measurement of gasket thickness and installed height		
			Torque Nm	Gasket thickness mm	Installed height <i>l</i>
M14 × 1,25	20 to 40	20 to 30	30	1,0 to 2,0	see <a href="#">Table 5</a>
M12 × 1,25	15 to 25	15 to 25	25	0,8 to 1,6	
M10 × 1	10 to 15	10 to 15	15	0,7 to 1,6	

**Table 4 — Tightening torque for spark-plugs with conical seating**

Thread size <i>n</i>	Cast-iron seating Torque Nm	Aluminum alloy seating Torque Nm	Measurement of installed height	
			Torque Nm	Installed height <i>l</i>
M18 × 1,5	20 to 30	not specified	30	see <a href="#">Table 7</a>
M14 × 1,25	10 to 20	10 to 20	20	
M12 × 1,25	10 to 20	10 to 15	15 (for Al alloy seating), 20 (for cast-iron seating)	

## 8 Spark-plug dimensions

### 8.1 Spark-plugs with flat seating

[Figures 4](#) to [11](#) show the design principle for spark-plugs with flat seating. The dimensions indicated in these figures are defined in [Tables 5](#) and [6](#).

Dimensions in millimetres

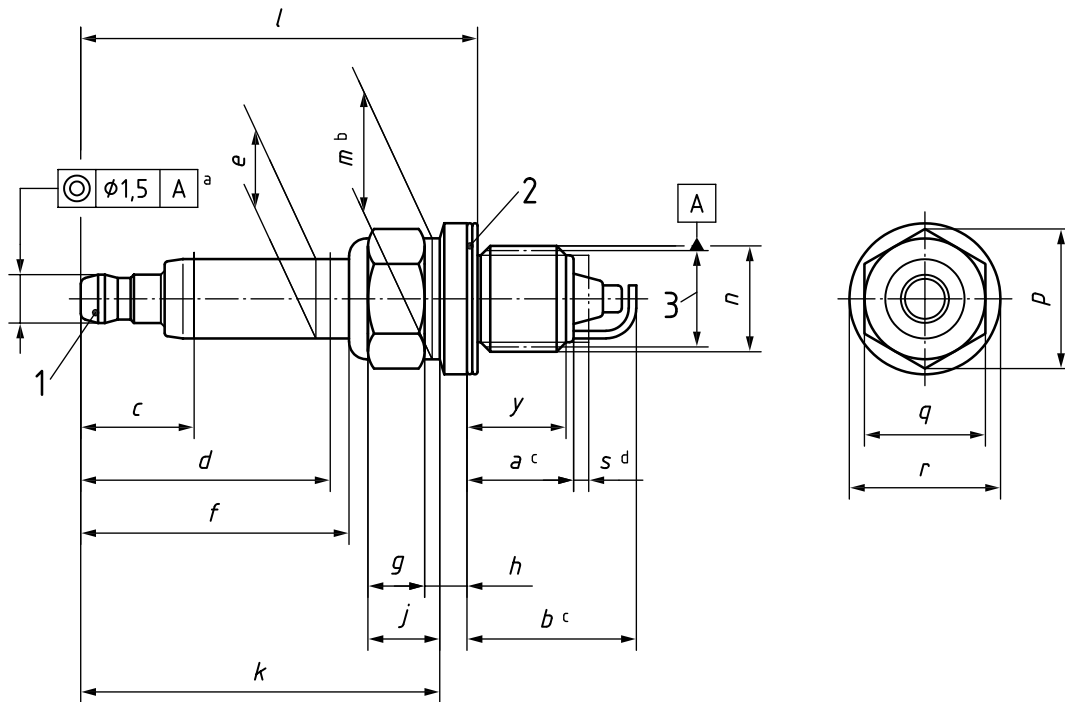

**Key**

- 1 solid post terminal
- 2 captive gasket
- 3 pitch diameter
- a This coaxiality does not apply to M14 × 1,25 spark-plugs with 20,8 mm hexagon, to all compact types of spark-plugs, and to spark-plugs with 12,7 mm reach.
- b Optional.
- c Dimension  $b-a$  is the spark-plug projection, which is the maximum protrusion of any part of the spark-plug into the combustion chamber.
- d Dimension  $s$  is the protrusion of the metal shell into the combustion chamber.

**Figure 4 — Spark-plug with solid post terminal, non-ribbed insulator, and hexagon**

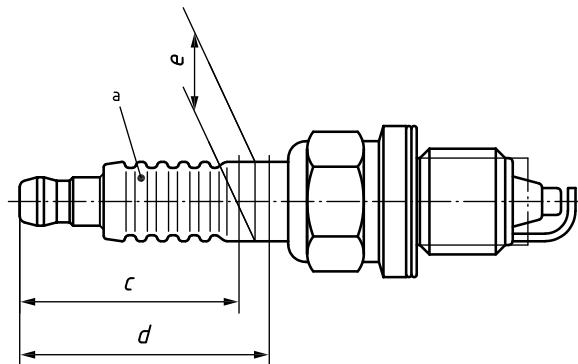

**Key**

- a Number and shape of ribs are optional.

**Figure 5 — Spark-plug with solid post terminal, ribbed insulator, and hexagon**



Dimensions in millimetres

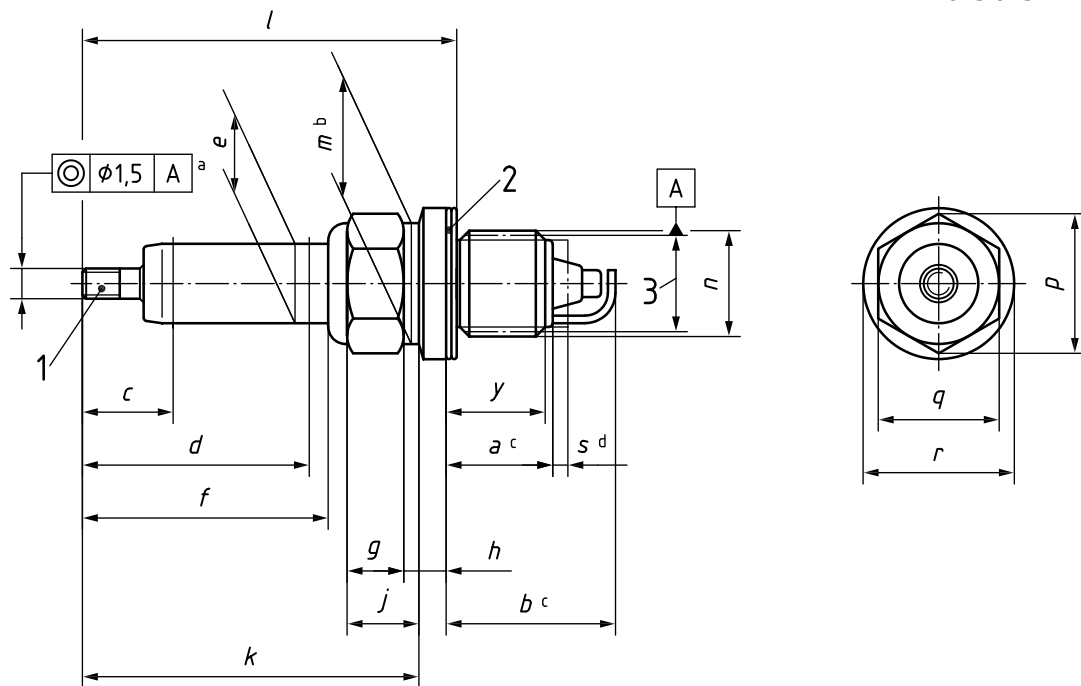

**Key**

- 1 threaded terminal
- 2 captive gasket
- 3 pitch diameter
- a This coaxiality does not apply to M14 × 1,25 spark-plugs with 20,8 mm hexagon, to all compact types of spark-plugs, and to spark-plugs with 12,7 mm reach.
- b Optional.
- c Dimension  $b-a$  is the spark-plug projection, which is the maximum protrusion of any part of the spark-plug into the combustion chamber.
- d Dimension  $s$  is the protrusion of the metal shell into the combustion chamber.

**Figure 6 — Spark-plug with threaded terminal, non-ribbed insulator, and hexagon**

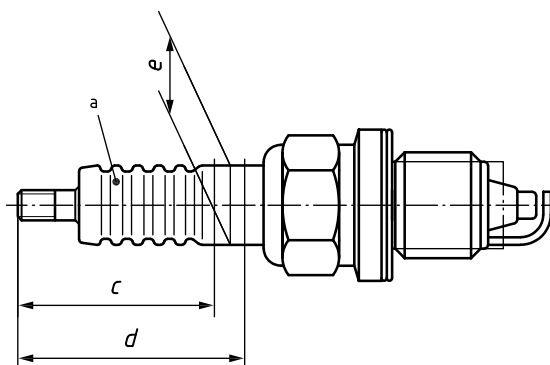

**Key**

- a Number and shape of ribs are optional.

**Figure 7 — Spark-plug with threaded terminal, ribbed insulator, and hexagon**

Dimensions in millimetres

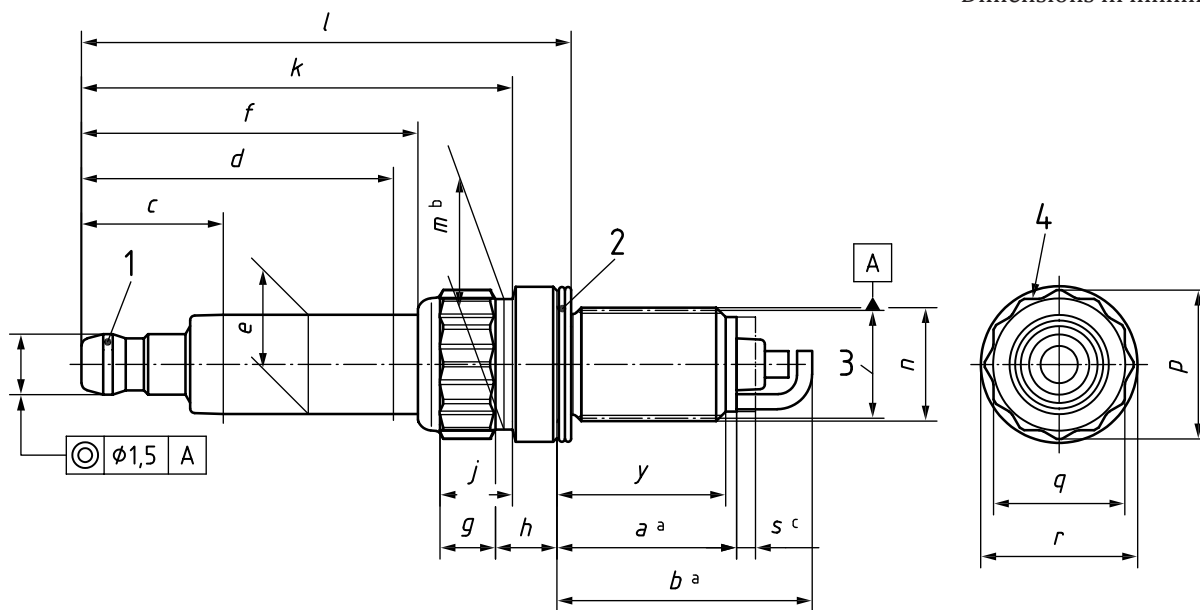

**Key**

- 1 solid post terminal
- 2 captive gasket
- 3 pitch diameter
- 4 bi-hexagon in accordance with ISO 4095 (except for tolerance of  $p$ )
- a Dimension  $b-a$  is the spark-plug projection, which is the maximum protrusion of any part of the spark-plug into the combustion chamber.
- b Optional.
- c Dimension  $s$  is the protrusion of the metal shell into the combustion chamber.

**Figure 8 — Spark-plug with solid post terminal, non-ribbed insulator, and bi-hexagon**

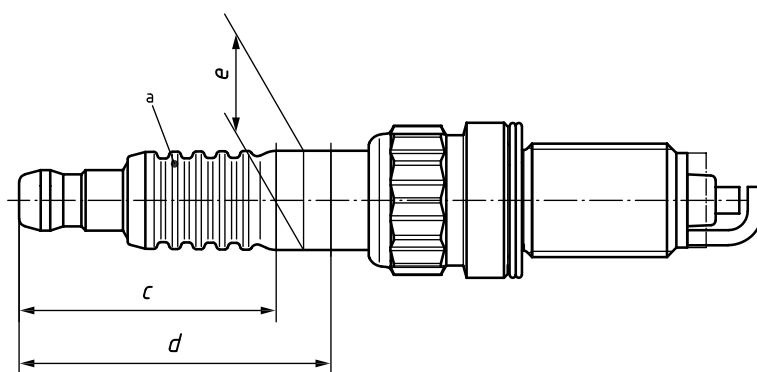

**Key**

- a Number and shape of ribs are optional.

**Figure 9 — Spark-plug with solid post terminal, ribbed insulator, and bi-hexagon**

Dimensions in millimetres

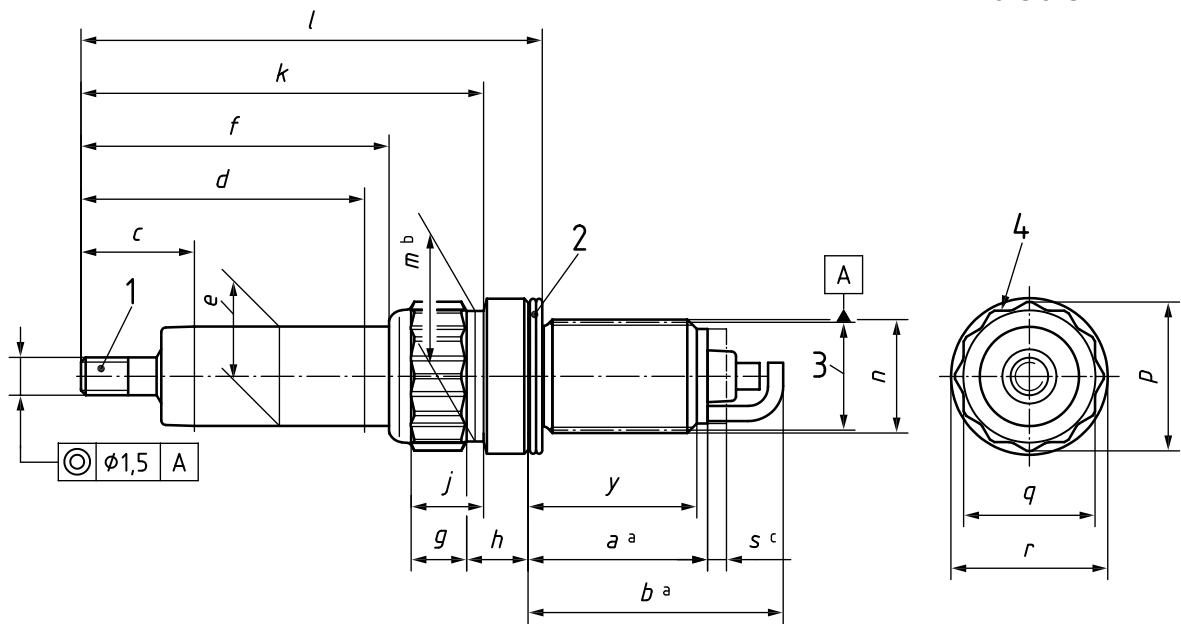

**Key**

- 1 threaded terminal
- 2 captive gasket
- 3 pitch diameter
- 4 bi-hexagon in accordance with ISO 4095 (except for tolerance of  $p$ )
- a Dimension  $b-a$  is the spark-plug projection, which is the maximum protrusion of any part of the spark-plug into the combustion chamber.
- b Optional.
- c Dimension  $s$  is the protrusion of the metal shell into the combustion chamber.

**Figure 10 — Spark-plug with threaded terminal, non-ribbed insulator, and bi-hexagon**

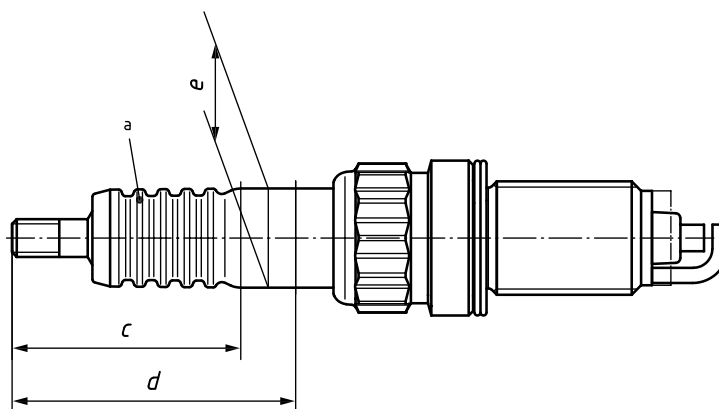

**Key**

- a Number and shape of ribs are optional.

**Figure 11 — Spark-plug with threaded terminal, ribbed insulator, and bi-hexagon**

Table 5 — Main dimensions of spark-plugs with flat seating

Dimensions in millimetres

Thread size <i>n</i>	Hexagon size <i>q</i>	Reach		Further shell dimensions			Installed height <i>l</i>		Insulator diameter <i>e</i> ±0,3	International Standard where formerly specified		
		Type <sup>a</sup>	<i>a</i> <sup>b</sup>	<i>s</i> <sup>b</sup>	<i>y</i> +0,3 -1,2	<i>b</i>	Solid post terminal	Threaded terminal				
M14 × 1,25	20,8	M	12,7	0	11,7	≤ 21	≤ 68	≤ 65	12,2	ISO 1919		
		L	19	0	18	≤ 27						
	19	S	9,5	0	9	≤ 16	≤ 48	≤ 45		ISO 2346		
	16	L	19	0	18	≤ 27	52,5 <sup>+1</sup> <sub>-2</sub>	49,5 ± 1,5	10,5	ISO 8470		
		EL	19	1,5 to 6	18	≤ 31						
		XL	26,5	0	25,5	≤ 34,5						
		EXL	26,5	1,5 to 6	25,5	≤ 38,5						
M12 × 1,25	16	L	19	0	18	≤ 27	52,5 <sup>+1</sup> <sub>-2</sub>	49,5 ± 1,5	10,5	ISO 2705		
		EL	19	1,5 to 6	18	≤ 31						
		XL	26,5	0	25,5	≤ 34,5						
		EXL	26,5	1,5 to 6	25,5	≤ 38,5						
	14	L	19	0	18	≤ 27					9,0	ISO 16246
		EL	19	1,5 to 6	18	≤ 31						
		XL	26,5	0	25,5	≤ 34,5						
		EXL	26,5	1,5 to 6	25,5	≤ 38,5						
	Bi-hex 14	L	19	0	18	≤ 27					10,5	ISO 22977
		EL	19	1,5 to 6	18	≤ 31						
		XL	26,5	0	25,5	≤ 34,5						
		EXL	26,5	1,5 to 6	25,5	≤ 38,5						
M10 × 1	16	M	12,7	0	11,7	≤ 21	52,5 <sup>+1</sup> <sub>-2</sub>	49,5 ± 1,5	10,5	ISO 2704		
		L	19	0	18	≤ 27						
		EL	19	1,5 to 6	18	≤ 31						
		XL	26,5	0	25,5	≤ 34,5						
		EXL	26,5	1,5 to 6	25,5	≤ 38,5						
		S	9,5	0	9	≤ 16			≤ 44,5	≤ 43		ISO 19812
	M	12,7	0	11,7	≤ 19							
	14	L	19	0	18	≤ 27	52,5 <sup>+1</sup> <sub>-2</sub>	49,5 ± 1,5	9,0	(new type)		
		XL	26,5	0	25,5	≤ 38,5						
	Bi-hex 12	L	19	0	18	≤ 27					7,5 <sup>c</sup>	(new type)
XL		26,5	0	25,5	≤ 38,5							

<sup>a</sup> See 5.1.

<sup>b</sup> The tolerance of (*a* + *s*) is ±0,2.

<sup>c</sup> If agreed between spark-plug and engine manufacturer, an insulator diameter of *e* = (8,0 ± 0,3) mm is also acceptable.

**Table 6 — Further dimensions of spark-plugs with flat seating**

Dimensions in millimetres

Thread size <i>n</i>	Hexagon size <i>q</i>	Terminal	Insulator	<i>c</i>	<i>d</i>	<i>f</i> <sub>min</sub>	<i>g</i> <sub>min</sub>	<i>h</i> <sub>min</sub>	<i>j</i> <sub>min</sub>	<i>k</i> <sub>min</sub>	$\emptyset$ <sub>m</sub> <sub>max</sub>	$\emptyset$ <i>r</i>	<i>p</i> <sub>min</sub>	International Standard where formerly specified	
M14 × 1,25	20,8 <sup>0</sup> <sub>-0,4</sub>	solid post	non-ribbed	15	33	a	4	10	a	a	a	≤ 20,8	23	ISO 1919	
			ribbed	29											
		threaded	non-ribbed	12	30										
			ribbed	26											
	19 h13	solid post	non-ribbed	15	24	a	3	3	a	a	a	a	21	ISO 2346	
			ribbed	20											
		threaded	non-ribbed	12	21										
			ribbed	17											
	16 h13	solid post	non-ribbed	15	33	34	4	4	5	44	16	≤ 20	17,5	ISO 8470	
			ribbed	29											
		threaded	non-ribbed	12	30										31
			ribbed	26											
M12 × 1,25	16 h13	solid post	non-ribbed	15	33	34	4	6	5	a	a	15,3 to 17,5	17,5	ISO 2705	
			ribbed	29											
		threaded	non-ribbed	12	30										31
			ribbed	26											
	14 h13	solid post	non-ribbed	15	33	34	4	6	5	44	14	≤ 17,5	15,4	ISO 16246	
			ribbed	29											
		threaded	non-ribbed	12	30										31
			ribbed	26											
	14 h13 Bi-hex	solid post	non-ribbed	15	33	34	4	6	5	44	14	≤ 17,5	15,4	ISO 22977	
			ribbed	29											
		threaded	non-ribbed	12	30										31
			ribbed	26											

<sup>a</sup> Value not specified in previous International Standards. To be determined for subsequent editions of this International Standard, as required.

Table 6 (continued)

Thread size <i>n</i>	Hexagon size <i>q</i>	Terminal	Insulator	<i>c</i>	<i>d</i>	<i>f</i> <sub>min</sub>	<i>g</i> <sub>min</sub>	<i>h</i> <sub>min</sub>	<i>j</i> <sub>min</sub>	<i>k</i> <sub>min</sub>	$\emptyset$ <i>m</i> <sub>max</sub>	$\emptyset$ <i>r</i>	<i>p</i> <sub>min</sub>	International Standard where formerly specified								
M10 × 1	16 h13	solid post	non-ribbed	15	33	34	4	6	a	a	a	≤ 16	17,5	ISO 2704								
			ribbed	29																		
		threaded	non-ribbed	12	30	31																
			ribbed	26																		
		solid post	non-ribbed	12	21	a									3	3	4	a	a	17,5	ISO 19812	
			ribbed	17																		
	threaded	non-ribbed	10,5	19,5																		
		ribbed	15,5																			
	14 h13	solid post	non-ribbed	15	33		34	4	6	5	44		14	15,4								(new type)
			ribbed	29																		
		threaded	non-ribbed	12	30	31																
			ribbed	26																		
12 h12 Bi-hex	solid post	non-ribbed	15	33	34	4	6	5	44	12	13,3	(new type)										
		ribbed	29																			
	threaded	non-ribbed	12	30	31																	
		ribbed	26																			

<sup>a</sup> Value not specified in previous International Standards. To be determined for subsequent editions of this International Standard, as required.

## 8.2 Spark-plugs with conical seating

Figures 12 to 15 show the design principle for spark-plugs with conical seating. The dimensions indicated in these figures are defined in Tables 7 and 8.

Dimensions in millimetres

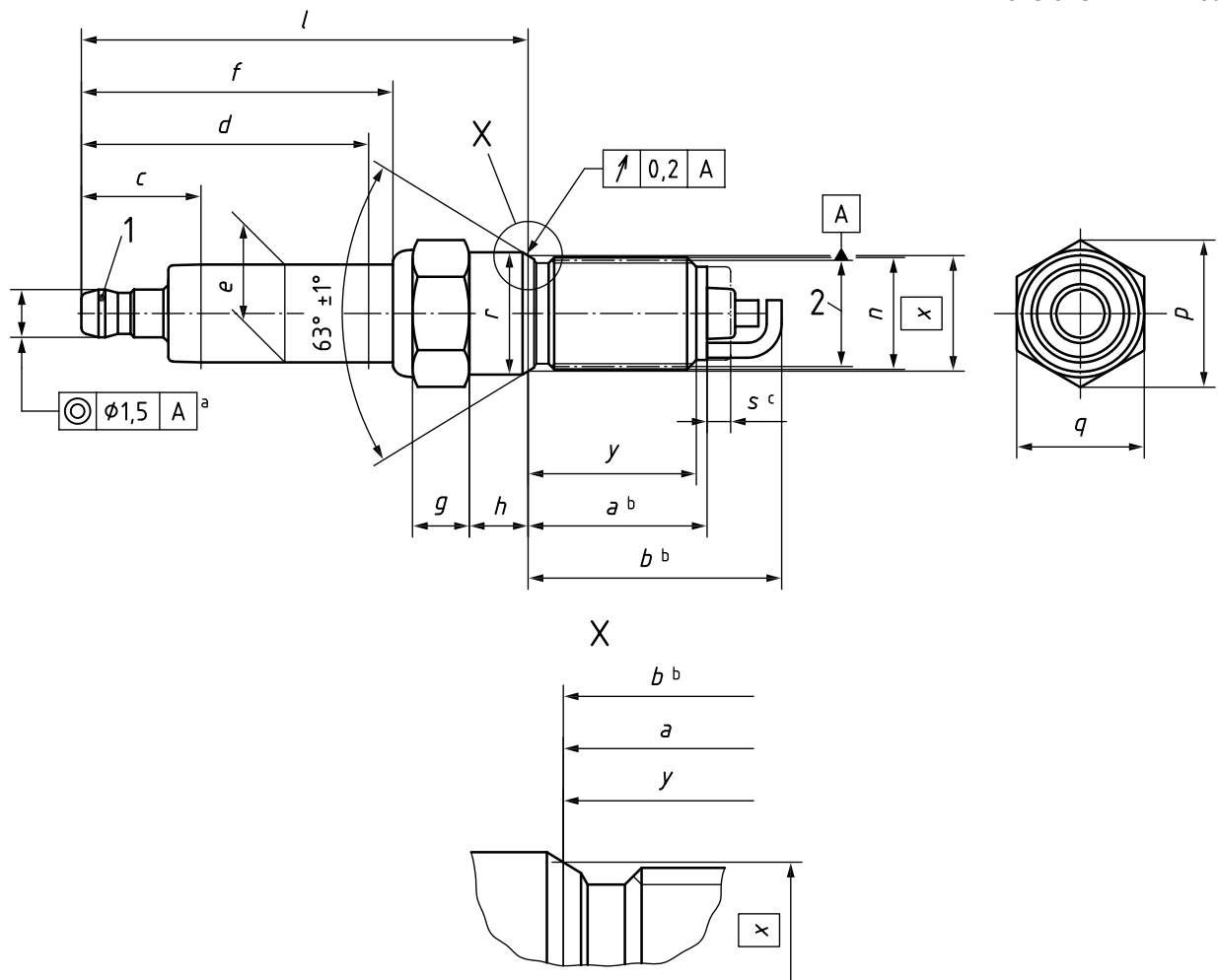

**Key**

- 1 solid post terminal
- 2 pitch diameter
- a This coaxiality does not apply to M18 × 1,5 spark-plugs or to any compact types of spark-plugs.
- b Dimension  $b-a$  is the spark-plug projection, which is the maximum protrusion of any part of the spark-plug into the combustion chamber.
- c Dimension  $s$  is the protrusion of the metal shell into the combustion chamber.

**Figure 12 — Spark-plug with solid post terminal and non-ribbed insulator**

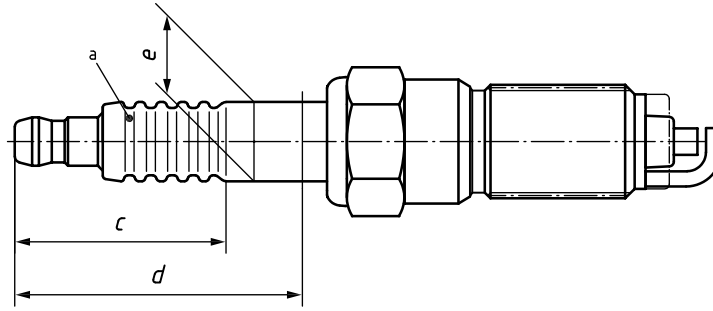

**Key**

- a Number and shape of ribs are optional.

**Figure 13 — Spark-plug with solid post terminal and ribbed insulator**



Dimensions in millimetres

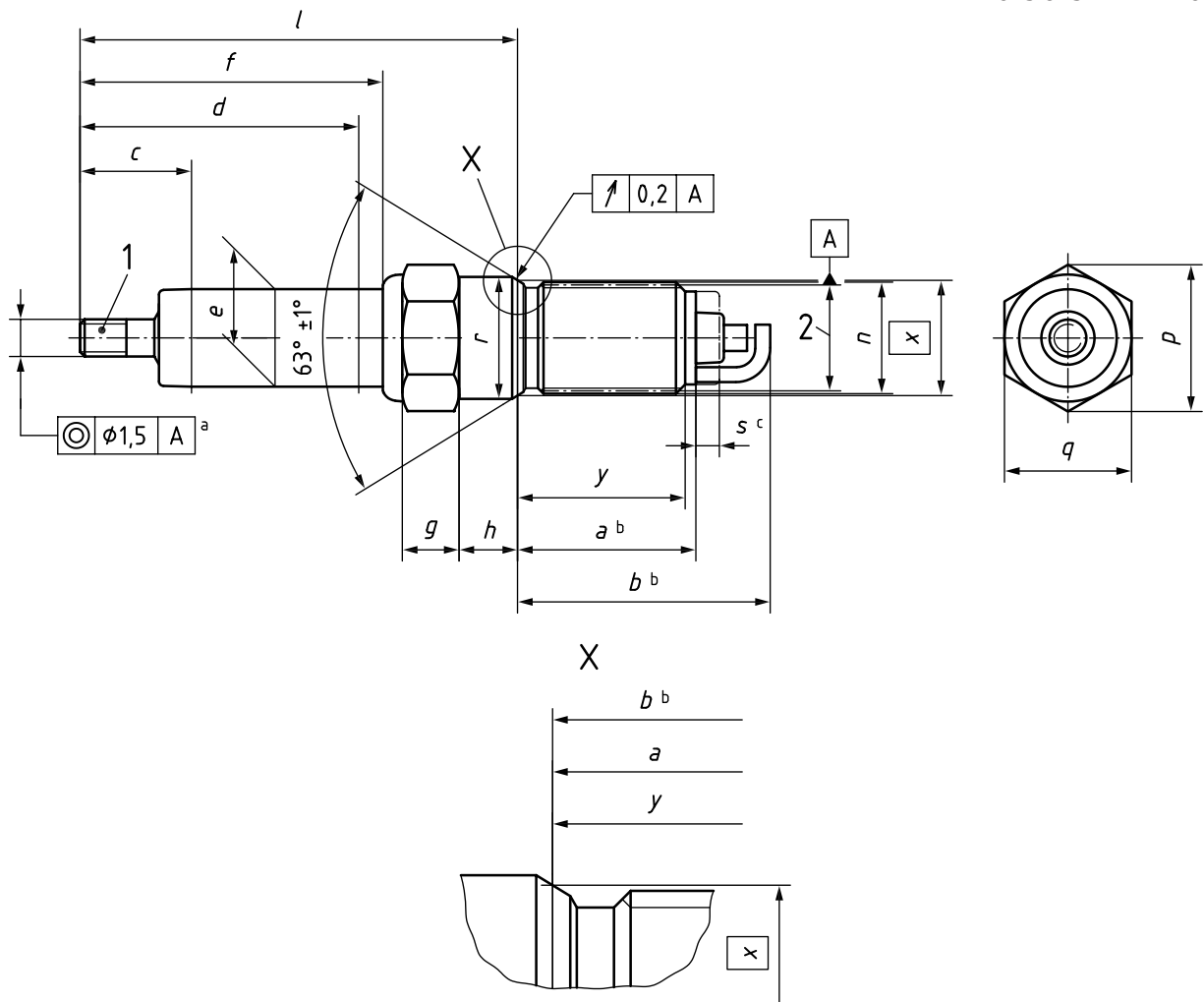

**Key**

- 1 threaded terminal
- 2 pitch diameter
- a This coaxiality does not apply to M18 × 1,5 spark-plugs or to any compact types of spark-plugs.
- b Dimension  $b-a$  is the spark-plug projection, which is the maximum protrusion of any part of the spark-plug into the combustion chamber.
- c Dimension  $s$  is the protrusion of the metal shell into the combustion chamber.

**Figure 14 — Spark-plug with threaded terminal and non-ribbed insulator**

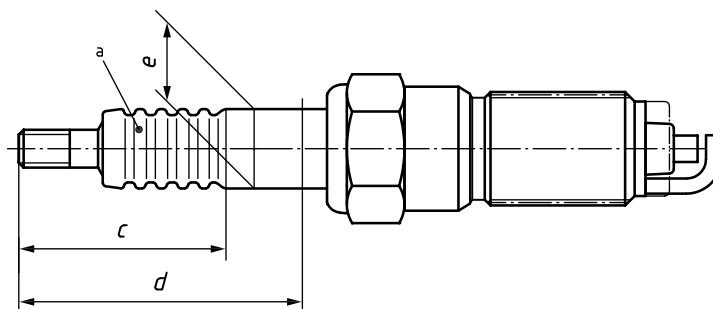

**Key**

a Number and shape of ribs are optional.

**Figure 15 — Spark-plug with threaded terminal and ribbed insulator**

**Table 7 — Main dimensions of spark-plugs with conical seating**

Dimensions in millimetres

Thread size <i>n</i>	Hexagon size <i>q</i>	Reach		Further shell dimensions			Installed height <i>l</i>		Insulator diameter <i>e</i> ±0,3	International Standard where formerly specified
		Type <sup>a</sup>	<i>a</i> <sup>b</sup>	<i>s</i> <sup>b</sup>	<i>y</i> +0,3 -1,2	<i>b</i>	Solid post terminal	Threaded terminal		
M18 × 1,5	20,8		10,9	<i>c</i>	9,9	≤ 20	≤ 68	≤ 65	12,2	ISO 2345
M14 × 1,25	16	M	11,2	<i>c</i>	10,2	≤ 19	53 <sup>+1</sup> <sub>-2</sub>	50 ± 1,5	10,5	ISO 2344
		L	17,5	<i>c</i>	16,5	≤ 25				
		XL	25	<i>c</i>	24	≤ 32,5				
		—	7,8	<i>c</i>	7,3	≤ 14	≤ 38	≤ 35	10,5	ISO 2347
M12 × 1,25	14	L	17,5	<i>c</i>	16,5	≤ 25	53 <sup>+1</sup> <sub>-2</sub>	n.a.	9,0	(new type)
		XL	25	<i>c</i>	24	≤ 32,5				

<sup>a</sup> See 5.1.

<sup>b</sup> The tolerance of (*a* + *s*) is ±0,3.

<sup>c</sup> Value not specified in previous International Standards. To be determined for subsequent editions of this International Standard, as required.

**Table 8 — Further dimensions of spark-plugs with conical seating**

Dimensions in millimetres

Thread size $n$	Hexagon size $q$	Terminal	Insulator	$c$	$d$	$f_{\min}$	$g_{\min}$	$h_{\min}$	$\varnothing r$	$\varnothing x$	$p_{\min}$	International Standard where formerly specified	
M18 × 1,5	20,8 <sup>0</sup> <sub>-0,4</sub>	solid post	non-ribbed	15	33	a	4	12	19,9 to 20,8	19	23	ISO 2345	
			ribbed	29									
		threaded	non-ribbed	12	30	a							
			ribbed	26									
M14 × 1,25	16 h13	solid post	non-ribbed	15	33	34	4	8,2	15,5 to 16,0	14,8	17,5	ISO 2344	
			ribbed	29									
		threaded	non-ribbed	12	30	31							
			ribbed	26									
		solid post	non-ribbed	15	24	a	3	3				ISO 2347	
			ribbed	20									
		threaded	non-ribbed	12	21	a							
			ribbed	17									
M12 × 1,25	14 h13	solid post	non-ribbed	15	33	34	4	8,2	13,4 to 14,3	12,8	15,4		(new type)
			ribbed	29									

<sup>a</sup> Value not specified in previous International Standards. To be determined for subsequent editions of this International Standard, as required.

## 9 Cylinder head housings

### 9.1 Cylinder head housing for spark-plugs with flat seating

[Figure 16](#) shows the design principle of the cylinder head housings for spark-plugs with flat seating. The dimensions indicated in [Figure 16](#) are defined in [Table 9](#).

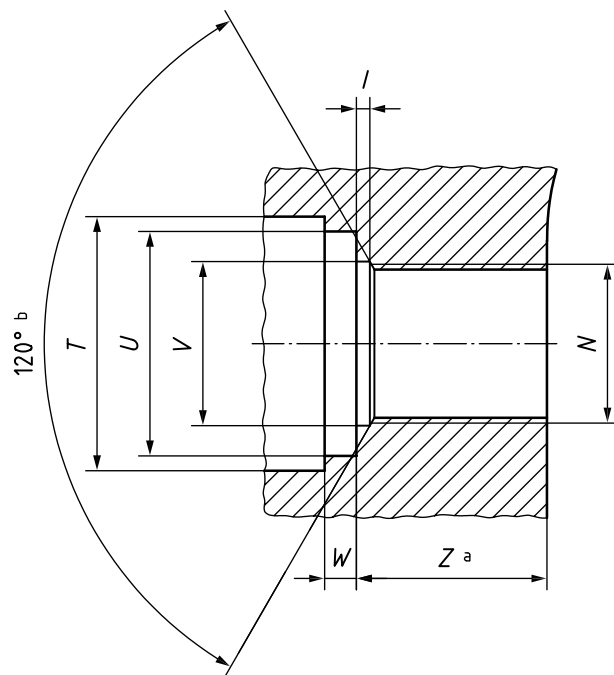

**Key**

- a The Z length of the cylinder head housing shall be sufficient to ensure that the end of the spark-plug thread does not project into the combustion chamber at any point when the spark-plug is tightened to maximum torque.
- b Nominal.

**Figure 16 — Cylinder head housing for flat seating**

**Table 9 — Cylinder head housing dimensions for flat seating**

Dimensions in millimetres

Thread size <i>N</i>	Hexagon size of spark-plug <i>q</i>	$\varnothing T_{\min}$	$\varnothing U_{\min}$	$\varnothing V_{\max}$	$W_{\max}$	$I_{\max}$	International Standard where formerly specified
M14 × 1,25	20,8	30	22	14,5	9	1,7	ISO 1919
	19				2		ISO 2346
	16	24	21,2		3		ISO 8470 <sup>a</sup>
M12 × 1,25	16	24	19	12,5	5		ISO 2705
	14	21					ISO 16246
	Bi-hex 14		ISO 22977				
M10 × 1	16	25	17	10,5	5		ISO 2704
	14	21			2 <sup>b</sup>	ISO 19812	
			Bi-hex 12		19	5	(new type)
							(new type)

<sup>a</sup> Combined seat in accordance with Annex C possible.

<sup>b</sup> Applied only to compact types of spark-plugs.

## 9.2 Cylinder head housing for spark-plugs with conical seating

Figure 17 shows the design principle of cylinder head housings of spark-plugs with conical seating. The dimensions indicated in Figure 17 are defined in Table 10.

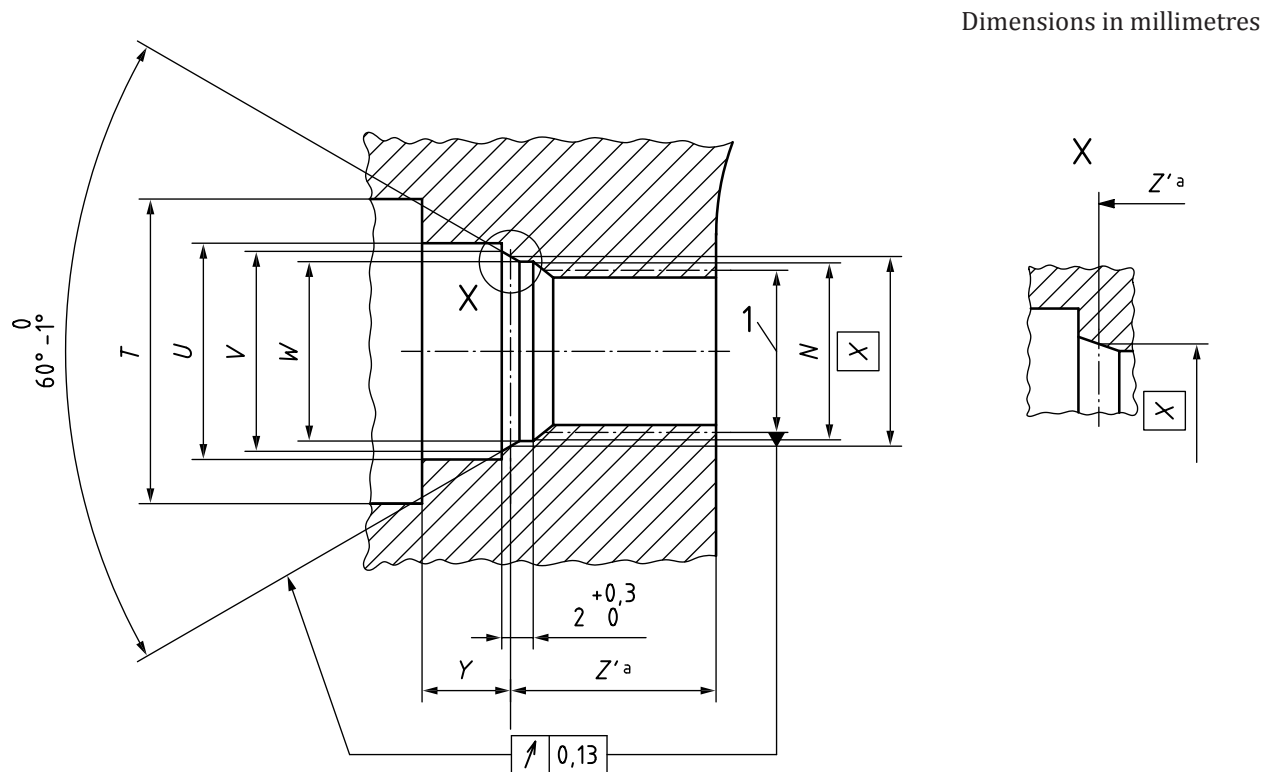

### Key

- 1 pitch diameter
- a The  $Z$  length of the cylinder head housing shall be sufficient to ensure that the end of the spark-plug thread does not project into the combustion chamber at any point when the spark-plug is tightened to maximum torque.

Figure 17 — Cylinder head housing for conical seating

Table 10 — Cylinder head housing dimensions for conical seating

Dimensions in millimetres

Thread size $N$	Hexagon size of spark-plug $q$	$\varnothing T_{\min}$	$\varnothing U_{\min}$	$\varnothing V$ $\begin{matrix} +0,3 \\ 0 \end{matrix}$	$\varnothing W$ $\begin{matrix} +0,15 \\ 0 \end{matrix}$	$\varnothing X$	$Y_{\max}$	International Standard where formerly specified
M18 × 1,5	20,8	31	22	19,5	18,25	19	9	ISO 2345
M14 × 1,25	16	24	17	15,1	14,25	14,8	5,5	ISO 2344 <sup>a</sup>
							2 <sup>b</sup>	ISO 2347
M12 × 1,25	14	21	15	13,1	12,25	12,8	5,5	(new type)

<sup>a</sup> Combined seat in accordance with Annex C possible.

<sup>b</sup> Applied only to compact types of spark-plugs.

## Annex A (normative)

### Spark-plugs with half thread and their cylinder head housings

[Figure A.1](#) shows the design principle of a spark-plug with half thread including the related dimensions. The dimensions of the cylinder head housing for spark-plugs with half thread are shown in [Figure A.2](#).

Dimensions in millimetres

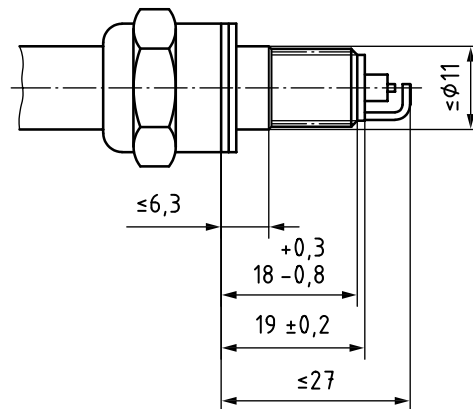
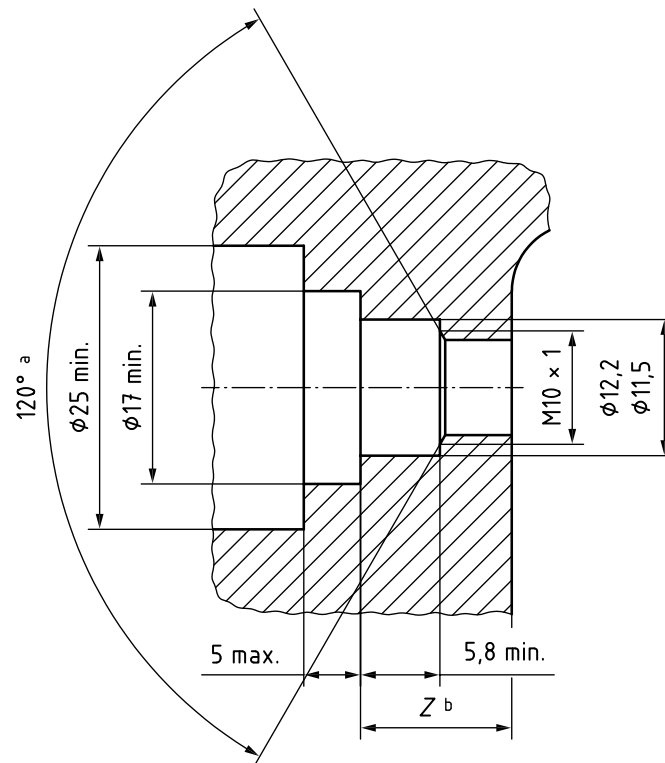

Figure A.1 — Spark-plug with half thread

Dimensions in millimetres



**Key**

- a Nominal.
- b The Z length of the cylinder head housing shall be sufficient to ensure that the end of the spark-plug thread does not project into the combustion chamber at any point when the spark-plug is tightened to maximum torque.

**Figure A.2 — Cylinder head housing for spark-plug with half thread**

## Annex B (informative)

### Optional terminals for compact spark-plugs

[Annex B](#) specifies the dimensions of the solid post terminals and threaded terminals for non-automotive application spark-plugs.

Dimensions in millimetres

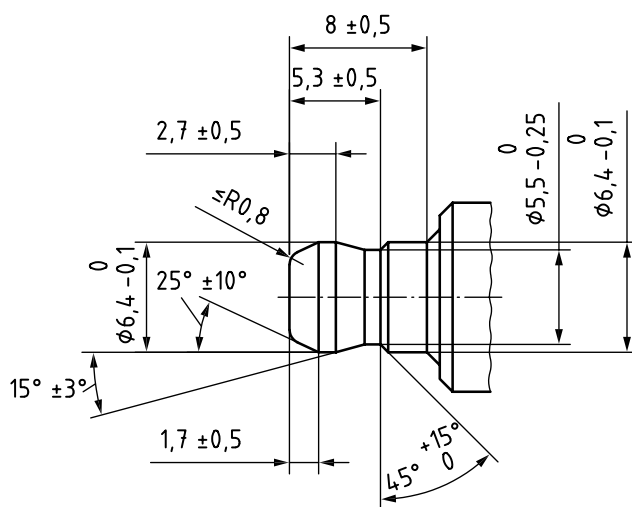

Figure B.1 — Solid post terminal for compact spark-plugs

Dimensions in millimetres

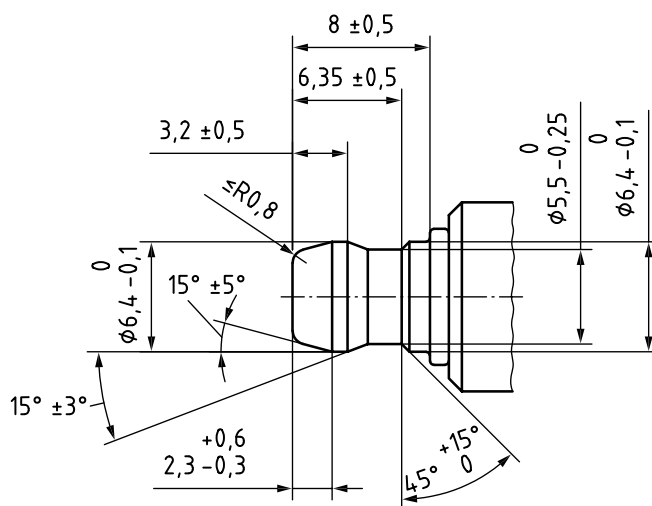
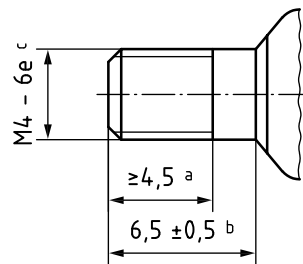

Figure B.2 — Alternative solid post terminal for compact spark-plugs



Dimensions in millimetres



**Key**

- a Length of usable thread.
- b Cylindrical part.
- c Depending on manufacturing process, class 7e is acceptable on finished product.

**Figure B.3 — Threaded terminal for compact spark-plugs**

## Annex C (informative)

### Optional combination cylinder head housing for spark-plugs with conical or flat seating

This combination cylinder head housing is only used for 14 mm spark-plugs with a shell seating diameter of less than 21 mm.

Dimensions in millimetres

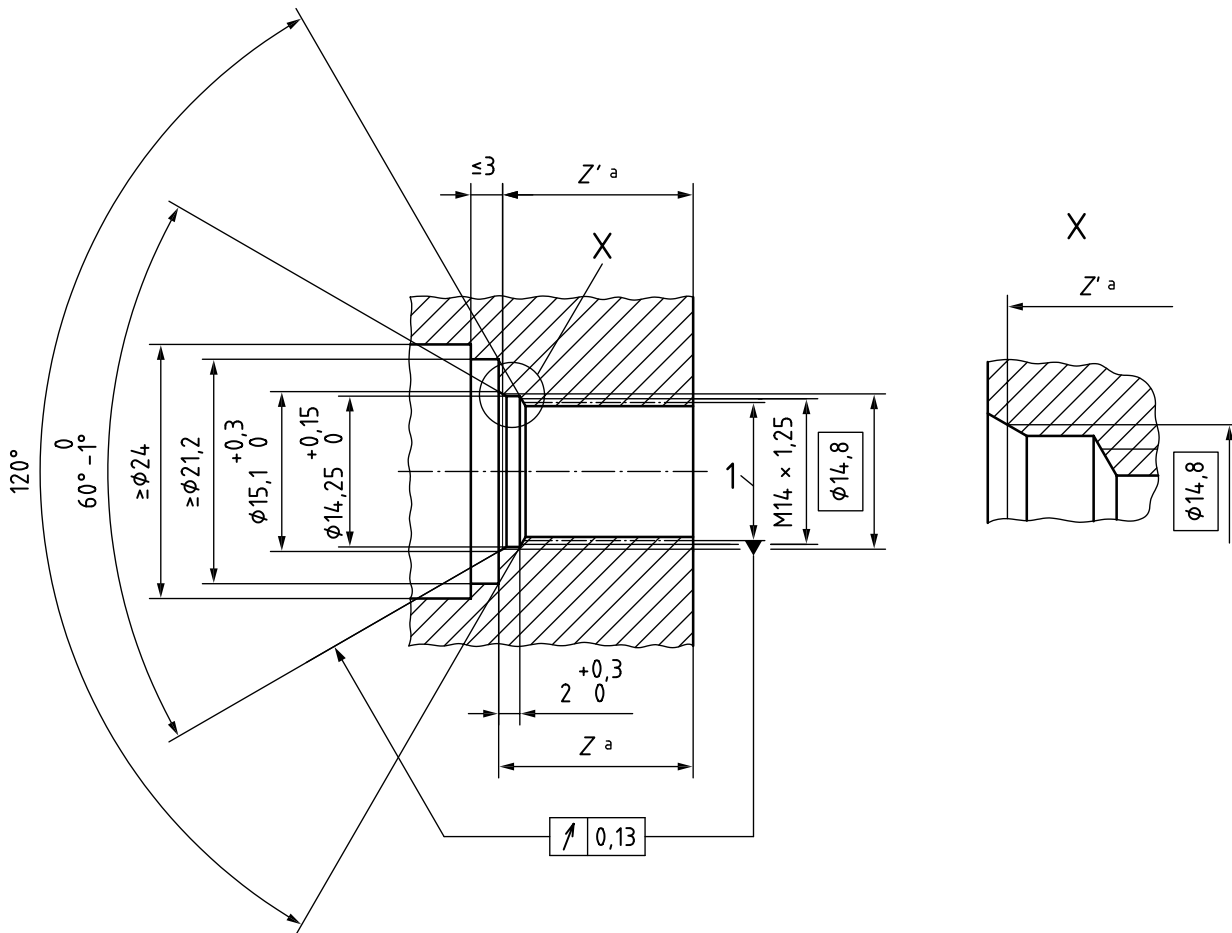

**Key**

- 1 pitch diameter
- a The  $Z$  and  $Z'$  lengths of the cylinder head housing shall be sufficient to ensure that the end of the spark-plug thread does not project into the combustion chamber at any point when the spark-plug is tightened to maximum torque.  $Z$  is the distance from the end of the cylinder head to the measurement point of the gauge diameter.

**Figure C.1 — Optional combination cylinder head housing**

## Bibliography

- [1] ISO 3412, *Road vehicles — Screened and waterproof spark-plugs and their connections — Types 1A and 1B*
- [2] ISO 3895, *Road vehicles — Screened and waterproof spark-plug and its connection — Type 2*
- [3] ISO 3896, *Road vehicles — Screened and waterproof spark-plug and its connection — Type 3*
- [4] ISO 11565, *Road vehicles — Spark-plugs — Test methods and requirements*





# British Standards Institution (BSI)

BSI is the national body responsible for preparing British Standards and other standards-related publications, information and services.

BSI is incorporated by Royal Charter. British Standards and other standardization products are published by BSI Standards Limited.

## About us

We bring together business, industry, government, consumers, innovators and others to shape their combined experience and expertise into standards-based solutions.

The knowledge embodied in our standards has been carefully assembled in a dependable format and refined through our open consultation process. Organizations of all sizes and across all sectors choose standards to help them achieve their goals.

## Information on standards

We can provide you with the knowledge that your organization needs to succeed. Find out more about British Standards by visiting our website at [bsigroup.com/standards](http://bsigroup.com/standards) or contacting our Customer Services team or Knowledge Centre.

## Buying standards

You can buy and download PDF versions of BSI publications, including British and adopted European and international standards, through our website at [bsigroup.com/shop](http://bsigroup.com/shop), where hard copies can also be purchased.

If you need international and foreign standards from other Standards Development Organizations, hard copies can be ordered from our Customer Services team.

## Subscriptions

Our range of subscription services are designed to make using standards easier for you. For further information on our subscription products go to [bsigroup.com/subscriptions](http://bsigroup.com/subscriptions).

With **British Standards Online (BSOL)** you'll have instant access to over 55,000 British and adopted European and international standards from your desktop. It's available 24/7 and is refreshed daily so you'll always be up to date.

You can keep in touch with standards developments and receive substantial discounts on the purchase price of standards, both in single copy and subscription format, by becoming a **BSI Subscribing Member**.

**PLUS** is an updating service exclusive to BSI Subscribing Members. You will automatically receive the latest hard copy of your standards when they're revised or replaced.

To find out more about becoming a BSI Subscribing Member and the benefits of membership, please visit [bsigroup.com/shop](http://bsigroup.com/shop).

With a **Multi-User Network Licence (MUNL)** you are able to host standards publications on your intranet. Licences can cover as few or as many users as you wish. With updates supplied as soon as they're available, you can be sure your documentation is current. For further information, email [bsmusales@bsigroup.com](mailto:bsmusales@bsigroup.com).

## BSI Group Headquarters

389 Chiswick High Road London W4 4AL UK

## Revisions

Our British Standards and other publications are updated by amendment or revision.

We continually improve the quality of our products and services to benefit your business. If you find an inaccuracy or ambiguity within a British Standard or other BSI publication please inform the Knowledge Centre.

## Copyright

All the data, software and documentation set out in all British Standards and other BSI publications are the property of and copyrighted by BSI, or some person or entity that owns copyright in the information used (such as the international standardization bodies) and has formally licensed such information to BSI for commercial publication and use. Except as permitted under the Copyright, Designs and Patents Act 1988 no extract may be reproduced, stored in a retrieval system or transmitted in any form or by any means – electronic, photocopying, recording or otherwise – without prior written permission from BSI. Details and advice can be obtained from the Copyright & Licensing Department.

## Useful Contacts:

### Customer Services

**Tel:** +44 845 086 9001

**Email (orders):** [orders@bsigroup.com](mailto:orders@bsigroup.com)

**Email (enquiries):** [cservices@bsigroup.com](mailto:cservices@bsigroup.com)

### Subscriptions

**Tel:** +44 845 086 9001

**Email:** [subscriptions@bsigroup.com](mailto:subscriptions@bsigroup.com)

### Knowledge Centre

**Tel:** +44 20 8996 7004

**Email:** [knowledgecentre@bsigroup.com](mailto:knowledgecentre@bsigroup.com)

### Copyright & Licensing

**Tel:** +44 20 8996 7070

**Email:** [copyright@bsigroup.com](mailto:copyright@bsigroup.com)



...making excellence a habit.™