



BSI Standards Publication

**Water quality — Determination
of 16 polycyclic aromatic
hydrocarbons (PAH) in
water — Method using gas
chromatography with mass
spectrometric detection (GC-
MS)**

National foreword

This British Standard is the UK implementation of ISO 28540:2011.

The UK participation in its preparation was entrusted to Technical Committee EH/3/2, Physical chemical and biochemical methods.

A list of organizations represented on this committee can be obtained on request to its secretary.

This publication does not purport to include all the necessary provisions of a contract. Users are responsible for its correct application.

© BSI 2011

ISBN 978 0 580 58732 0

ICS 13.060.50

Compliance with a British Standard cannot confer immunity from legal obligations.

This British Standard was published under the authority of the Standards Policy and Strategy Committee on 31 August 2011.

Amendments issued since publication

Date	Text affected
------	---------------

**Water quality — Determination of
16 polycyclic aromatic hydrocarbons
(PAH) in water — Method using gas
chromatography with mass spectrometric
detection (GC-MS)**

*Qualité de l'eau — Détermination de 16 hydrocarbures aromatiques
polycycliques (HAP) dans l'eau — Méthode par chromatographie en
phase gazeuse avec détection par spectrométrie de masse (CG-SM)*





COPYRIGHT PROTECTED DOCUMENT

© ISO 2011

All rights reserved. Unless otherwise specified, no part of this publication may be reproduced or utilized in any form or by any means, electronic or mechanical, including photocopying and microfilm, without permission in writing from either ISO at the address below or ISO's member body in the country of the requester.

ISO copyright office
Case postale 56 • CH-1211 Geneva 20
Tel. + 41 22 749 01 11
Fax + 41 22 749 09 47
E-mail copyright@iso.org
Web www.iso.org

Published in Switzerland

Contents

Page

Foreword	iv
Introduction.....	v
1 Scope	1
2 Normative references	1
3 Terms and definitions	1
4 Principle	2
5 Interferences	4
6 Reagents	4
7 Apparatus	7
8 Sampling	8
9 Procedure	8
10 Calibration	11
11 Measurement of samples.....	12
12 Identification	12
13 Calculation	14
14 Expression of results	16
15 Test report.....	17
Annex A (informative) Examples for GC-MS conditions.....	18
Annex B (informative) Precision and accuracy.....	19
Annex C (informative) Examples of the construction of special apparatus	22
Annex D (informative) Example of chromatograms	24
Annex E (informative) Extraction with extraction disks.....	26
Bibliography.....	27

Foreword

ISO (the International Organization for Standardization) is a worldwide federation of national standards bodies (ISO member bodies). The work of preparing International Standards is normally carried out through ISO technical committees. Each member body interested in a subject for which a technical committee has been established has the right to be represented on that committee. International organizations, governmental and non-governmental, in liaison with ISO, also take part in the work. ISO collaborates closely with the International Electrotechnical Commission (IEC) on all matters of electrotechnical standardization.

International Standards are drafted in accordance with the rules given in the ISO/IEC Directives, Part 2.

The main task of technical committees is to prepare International Standards. Draft International Standards adopted by the technical committees are circulated to the member bodies for voting. Publication as an International Standard requires approval by at least 75 % of the member bodies casting a vote.

Attention is drawn to the possibility that some of the elements of this document may be the subject of patent rights. ISO shall not be held responsible for identifying any or all such patent rights.

ISO 28540 was prepared by Technical Committee ISO/TC 147, *Water quality*, Subcommittee SC 2, *Physical, chemical and biochemical methods*.

Introduction

Polycyclic aromatic hydrocarbons (PAH) occur in nearly all types of water, these substances are adsorbed on solids (sediments, suspended matter) as well as dissolved in the liquid phase.

ISO 17993^[7] specifies methods for the determination of 15 PAH by high performance liquid chromatography in drinking water, ground water, and surface water.

ISO 7981-1^[3] and ISO 7981-2^[4] specify methods for the determination of 6 PAH by high performance thin layer chromatography or by high performance liquid chromatography in drinking water and ground water.

This International Standard describes a method for at least 16 PAH using gas chromatography with mass spectrometric detection (GC-MS) in drinking water, ground water and surface water.

Some PAH are known or suspected to cause cancer. Maximum acceptable levels have been set in a number of countries. For instance, the European Council Directive 98/83/EC on the quality of water intended for human consumption (Reference [10]) set the maximum acceptable level for benzo[*a*]pyrene at 0,010 µg/l, and for the sum of four specified PAH (benzo[*b*]fluoranthene, benzo[*k*]fluoranthene, benzo[*ghi*]perylene, indeno[1,2,3-*cd*]pyrene) at 0,100 µg/l.

Water quality — Determination of 16 polycyclic aromatic hydrocarbons (PAH) in water — Method using gas chromatography with mass spectrometric detection (GC-MS)

WARNING — Persons using this International Standard should be familiar with normal laboratory practice. This standard does not purport to address all of the safety problems, if any, associated with its use. It is the responsibility of the user to establish appropriate safety and health practices and to ensure compliance with any national regulatory conditions.

IMPORTANT — It is absolutely essential that tests conducted according to this International Standard be carried out by suitably trained staff.

1 Scope

This International Standard specifies a method for the determination of at least 16 selected PAH (see Table 1) in drinking water and ground water in mass concentrations above 0,005 µg/l and in surface water in mass concentrations above 0,01 µg/l (for each individual compound).

This International Standard can be used for samples containing up to 150 mg/l of suspended matter.

This method is, with some modification, also suitable for the analysis of waste water. It is possible that this method is applicable to other PAH, provided the method is validated for each case.

2 Normative references

The following referenced documents are indispensable for the application of this document. For dated references, only the edition cited applies. For undated references, the latest edition of the referenced document (including any amendments) applies.

ISO 5667-1, *Water quality — Sampling — Part 1: Guidance on the design of sampling programmes and sampling techniques*

ISO 5667-3, *Water quality — Sampling — Part 3: Preservation and handling of water samples*

ISO 8466-1, *Water quality — Calibration and evaluation of analytical methods and estimation of performance characteristics — Part 1: Statistical evaluation of the linear calibration function*

3 Terms and definitions

For the purposes of this document, the following terms and definitions apply.

3.1

analyte

substance to be determined

[ISO 15089:2000^[5], 3.2]

NOTE Substances determinable by this International Standard are listed in Table 1.

3.2 calibration solution
solution prepared from a secondary standard and/or stock solutions and used to calibrate the response of the instrument with respect to analyte concentration

[ISO 18073:2004^[8], 3.1.2]

3.3 GC-MS determination diagnostic ion
selected fragment or molecular ion of the target compound with the highest possible specificity

3.4 injection standard
standard mixture added to a sample before injection into the GC-MS apparatus, to monitor variability of instrument response and to calculate internal standard recovery

NOTE In this International Standard, the injection standard mixture contains an isotopically labelled PAH.

3.5 internal standard
isotopically labelled PAH or PAH unlikely to be present in the sample, added to samples prior to extraction, against which the concentrations of native substances are calculated

3.6 selected ion monitoring/recording mode SIM/SIR
measuring the intensity of selected diagnostic ions only

NOTE Adapted from ISO 22892:2006^[9], 3.8.

4 Principle

The PAH (see Table 1) present in the aqueous sample are extracted from the water sample by liquid-liquid extraction with hexane. An internal standard mixture is added to the sample prior to extraction. The extract is concentrated by evaporation, and the residue taken up in a solvent appropriate for clean-up or GC analysis.

NOTE 1 Other volatile solvents can be used as well if it is proven that there is equal or better recovery (recovery mass fraction between 70 % and 110 %).

The liquid-liquid extraction method shall not be used with samples containing more than 150 mg/l of suspended matter.







WARNING — The use of this International Standard may involve hazardous materials, operations and equipment. This International Standard does not purport to address all the safety problems associated with its use. It is the responsibility of the user of this standard to establish appropriate safety and health practices and determine the applicability of regulatory limitations prior to use.

NOTE 2 For samples that contain more than 150 mg/l suspended matter the procedure described in ISO 17858:2007^[6], 4.1, 4.2 and 4.3, can be used.

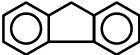
If necessary, extracts of surface water samples can be cleaned by column chromatography prior to analysis. Prior to injection, injection standards are added to each extract, and an aliquot of the extract is injected into the gas chromatograph.

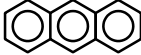
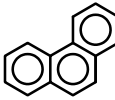
PAH are separated on a suitable fused silica capillary column, coated with a film of cross-linked non-polar polysiloxane or slightly polar modified polysiloxane with an efficient separation. The column shall be suitable for separating benzo[a]pyrene and benzo[e]pyrene. Identification and quantification is performed by means of mass spectrometry using electron impact ionization (EI).

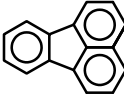
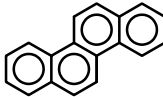
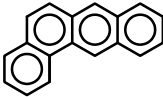
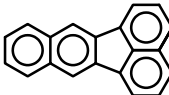
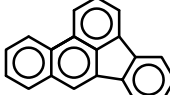
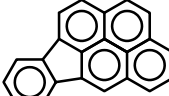
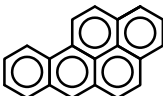
Table 1 — Polycyclic aromatic hydrocarbons determinable by this International Standard

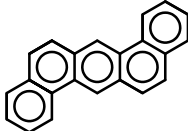
Name Chemical formula Molar mass % carbon CAS number	Structure	Name Chemical formula Molar mass % carbon CAS number	Structure
Naphthalene C ₁₀ H ₈ 128,17 g/mol 93,75 % C 91-20-3		Fluorene C ₁₃ H ₁₀ 166,22 g/mol 93,59 % C 86-73-7	
Acenaphthylene C ₁₂ H ₈ 152,20 g/mol 94,6 % C 208-96-8		Acenaphthene C ₁₂ H ₁₀ 154,21 g/mol 93,05 % C 83-32-9	
Anthracene C ₁₄ H ₁₀ 178,23 g/mol 94,05 % C 120-12-7		Phenanthrene C ₁₄ H ₁₀ 178,23 g/mol 94,05 % C 85-01-8	
Pyrene C ₁₆ H ₁₀ 202,26 g/mol 95,0 % C 129-00-0		Fluoranthene C ₁₆ H ₁₀ 202,26 g/mol 95,0 % C 206-44-0	
Chrysene C ₁₈ H ₁₂ 228,29 g/mol 94,45 % C 218-01-9		Benzo[a]anthracene C ₁₈ H ₁₂ 228,29 g/mol 94,45 % C 56-55-3	
Benzo[k]fluoranthene ^a C ₂₀ H ₁₂ 252,32 g/mol 95,2 % C 207-08-9		Benzo[b]fluoranthene ^a C ₂₀ H ₁₂ 252,32 g/mol 95,2 % C 205-99-2	
Indeno[1,2,3-cd]pyrene ^a C ₂₂ H ₁₂ 276,34 g/mol 95,6 % C 193-39-5		Benzo[a]pyrene ^a C ₂₀ H ₁₂ 252,32 g/mol 95,2 % C 50-32-8	
Benzo[ghi]perylene ^a C ₂₂ H ₁₂ 276,34 g/mol 95,6 % C 191-24-2		Dibenzo[a,h]anthracene ^a C ₂₂ H ₁₄ 278,35 g/mol 94,7 % C 53-70-3	

^a Compound specified by Council Directive 98/93/EC (Reference [10]).

5 Interferences

5.1 Interferences with sampling, extraction, and concentration

Use sampling containers of materials that do not affect the analyte content during the contact time (preferably of stainless steel or glass). Avoid plastics and other organic materials during sampling, sample storage or extraction. Care should be taken when using surfactants for cleaning sample containers, because they may lead to the formation of emulsions during liquid-liquid extraction.

If automatic samplers are used, avoid the use of silicone or rubber material for the tubes. If these materials are present, ensure that the contact time is minimized. Rinse the sampling line with the water to be sampled before taking the test sample. Use ISO 5667-1 and ISO 5667-3 for guidance.

Keep the test samples away from direct sunlight and prolonged exposure to light. Store the samples in amber containers. Clear glass bottles are suitable as well, but then the samples shall be kept in a dark place.

During storage of the test samples, losses of PAH may occur due to adsorption on to the walls of the containers. The extent of the losses may depend on the storage time.

5.2 Interferences with GC-MS

Substances that co-elute with the target PAH may interfere with the determination. These interferences may lead to incompletely resolved signals and may, depending on their magnitude, affect accuracy and precision of the analytical results. Non-symmetrical peaks and peaks broader than the corresponding peaks of the reference substance suggest interferences.

Chromatographic separation between dibenzo[*a,h*]anthracene and indeno[1,2,3-*cd*]pyrene is most critical. Due to their molecular mass differences, quantification can be made by mass selective detection. When incomplete resolution is encountered, peak integration shall be checked and, when necessary, the baseline corrected. Sufficient resolution (e.g. not less than $R = 0,8$) between the peaks of benzo[*b*]fluoranthene and benzo[*k*]fluoranthene as well as of benzo[*a*]pyrene and benzo[*e*]pyrene is to be set as quality criterion for the capillary column. Benzo[*j*]fluoranthene cannot be separated from benzo[*k*]fluoranthene and benzo[*b*]fluoranthene. It is possible that triphenylene is not completely separated from benzo[*a*]anthracene and chrysene. If this is the case, state this fact in the test report.

NOTE Benzo[*j*]fluoranthene, benzo[*e*]pyrene, and triphenylene are not part of the 16 target analytes.

6 Reagents

WARNING — The use of this International Standard may involve hazardous materials, operations and equipment. This International Standard does not purport to address all the safety problems associated with its use. It is the responsibility of the user of this standard to establish appropriate safety and health practices and determine the applicability of regulatory limitations prior to use.

During the analysis, unless otherwise stated, use only reagents of recognized analytical grade, “for residue analysis” or “for GC analysis”, where appropriate, and distilled or demineralized water or water of equivalent purity. Otherwise, pay extra attention that each batch of solvents does not contain blank concentrations affecting the results.

6.1 Sodium thiosulfate pentahydrate, $\text{Na}_2\text{S}_2\text{O}_3 \cdot 5\text{H}_2\text{O}$, for dechlorination.

6.2 Solvents.

6.2.1 Hexane, C_6H_{14} .

6.2.2 Acetonitrile, CH_3CN .

6.2.3 Acetone, C_3H_6O .

6.2.4 Decane, $C_{10}H_{22}$.

6.2.5 Isooctane, C_8H_{18} .

6.2.6 Dichloromethane, CH_2Cl_2 .

6.3 Sodium sulfate, Na_2SO_4 , anhydrous, precleaned by heating to 500 °C for 4 h or free of interfering compounds.

6.4 Gases.

6.4.1 Nitrogen, 99,999 % volume fraction, for the purpose of evaporating the extracts.

6.4.2 Helium, 99,999 % volume fraction, for gas chromatography.

6.5 Standards.

6.5.1 Reference substances (see Table 2) and internal standards.

Choose internal standards with physical and chemical properties (such as extraction behaviour, retention time) that are similar to those of the compounds to be analysed.

Use a minimum of three internal standards, e.g. three deuterated PAH, for evaluation of results (see Clauses 11 and 12). Verify the stability of the internal standards regularly. Table 2 contains native PAH and a number of deuterated PAH that can be used. The internal standards are added to the sample to be extracted and are therefore dissolved in a water-soluble solvent.

NOTE 1 ^{13}C isotopically labelled PAH standards can also be used as internal standards.

NOTE 2 Certified solutions of PAH and single solid PAH substances with certified purity are available from a limited number of suppliers¹⁾ or from other commercial providers.

Because of the dangerous nature of these substances, commercially available, preferably certified, standard solutions should be used. Skin contact should be avoided.

6.5.2 Injection standard.

Add an isotopically labelled non-polar substance to the final extract and to the calibration solutions (6.8) before GC-MS injection to check the recovery of the internal standards.

Prepare a stock solution of the injection standard in an appropriate solvent of mass concentration $\rho \approx 10 \mu\text{g/ml}$.

6.6 Single substance stock solutions.

Prepare solutions of the single substances (see Table 1) in an appropriate solvent, e.g. hexane (6.2.1) or acetonitrile (6.2.2), with mass concentration $\rho \approx 200 \mu\text{g/ml}$.

These solutions can be used for confirmation and identification of single PAH in the chromatogram.

1) The Institute for Reference Materials and Measurements (IRMM), Geel, Belgium, the National Institute of Science and Technology (NIST), Washington DC, USA, and the Cambridge Isotope Laboratory (CIL), Andover, MA, USA, are examples of suitable product suppliers. This information is given for the convenience of users of this International Standard and does not constitute an endorsement of these suppliers by ISO.

6.7 Multiple substance stock solution.

Dilute a sufficient volume (e.g. 5 ml) of the single substance stock solutions (6.6) in a one-mark volumetric flask (7.14, e.g. 100 ml) with an appropriate solvent, e.g. hexane (6.2.1) or acetonitrile (6.2.2), to prepare a solution of mass concentration $\rho \approx 10 \mu\text{g/ml}$.

Alternative commercially available (certified) combined and mixed solutions containing only one or some of the reference substances (see Table 1) at an appropriate mass concentration of the relevant single substance, e.g. 10 $\mu\text{g/ml}$ in an appropriate solvent, such as acetonitrile (6.2.2) or hexane (6.2.1), may be used.

The solutions 6.5 to 6.7 are stable for at least 1 year when stored in the dark at room temperature and protected from evaporation. Check the stability of the standard solution regularly. For that purpose, independent solutions for quality control shall be available within a laboratory.

Table 2 — Native PAH and deuterated PAH

PAH reference substances	Labelled internal standard substances deuterated PAH
Naphthalene (CAS No. 91-20-3)	Naphthalene-d8 (CAS No. 1146-65-2)
Acenaphthene (CAS No. 83-32-9)	Acenaphthene-d10 (CAS No. 15067-26-2)
Acenaphthylene (CAS No. 208-96-8)	Acenaphthylene-d8 (CAS No. 93951-97-4)
Fluorene (CAS No. 86-73-7)	Fluorene-d10 (CAS No. 81103-79-9)
Anthracene (CAS No. 120-12-7)	Anthracene-d10 (CAS No. 1719-06-8)
Phenanthrene (CAS No. 85-01-8)	Phenanthrene-d10 (CAS No. 1517-22-2)
Fluoranthene (CAS No. 206-44-0)	Fluoranthene-d10 (CAS No. 93951-69-0)
Pyrene (CAS No. 129-00-0)	Pyrene-d10 (CAS No. 1718-52-1)
Benzo[a]anthracene (CAS No. 56-55-3)	Benzo[a]anthracene-d12 (CAS No. 1718-53-2)
Chrysene (CAS.No. 218-01-9)	Chrysene-d12 (CAS No. 1719-03-5)
Benzo[b]fluoranthene (CAS No. 205-99-2)	Benzo[b]fluoranthene-d12 (CAS No. 93951-98-5)
Benzo[j]fluoranthene ^a (CAS No. 205-82-3)	
Triphenylene ^a (CAS No 217-59-4)	
Benzo[k]fluoranthene (CAS No. 207-08-9)	Benzo[k]fluoranthene-d12 (CAS No. 93952-01-3)
Benzo[a]pyrene (CAS No. 50-32-8)	Benzo[a]pyrene-d12 (CAS No. 63466-71-7)
Benzo[e]pyrene ^a (CAS No. 192-97-2)	
Indeno[1,2,3-cd]pyrene (CAS No. 193-39-5)	Indeno[1,2,3-cd]pyrene-d12 (CAS No. 203578-33-0)
Dibenzo[a,h]anthracene (CAS No. 53-70-3)	Dibenzo[a,h]anthracene-d14 (CAS No. 13250-98-1)
Benzo[ghi]perylene (CAS No. 191-24-2)	Benzo[ghi]perylene-d12 (CAS No. 93951-66-7)
^a Not one of the 16 target analytes; used only to check that resolution is sufficient.	

6.8 Calibration solutions.

Prepare at least five calibration solutions by appropriate dilution of the multiple substance stock solution (6.7), using hexane (6.2.1) or acetonitrile (6.2.2) as solvent. Add to each solution the same amount of the stock solution of the injection standard to give a final concentration of $\rho \approx 100$ ng/ml.

It is recommended that the solvent for the calibration solutions be the same as the solution of the final extract.

Transfer, for example, 50 μ l of the multiple stock solution into a 5 ml one-mark volumetric flask (7.14) and make up to the mark with appropriate solvent. A volume of 1 μ l of this reference solution contains 100 pg of the respective individual substances ($\rho \approx 100$ ng/ml).

The mass concentration of the PAH in the multiple substance stock solution shall be checked by comparison with an independent, preferably certified, standard solution. All individual substances shall agree within ± 10 %.

These solutions shall be used for the calibration of the gas chromatographic system (mixture in hexane) as well as for the addition of internal standards [mixture in acetonitrile (6.2.2.)].

7 Apparatus

Usual laboratory equipment and in particular the following. Clean laboratory glassware to eliminate all interferences.

NOTE All glassware can be cleaned, for example, by rinsing with detergent and hot water, and drying for about 15 min to 30 min at about 120 °C. After cooling, the glassware can be rinsed with acetone (6.2.3), sealed, and stored in a clean environment.

For drinking water analysis, do not re-use glassware that has been in contact with waste water samples or samples with high PAH concentrations.

- 7.1 **Coloured or clear glass bottles**, narrow-necked, flat-bottomed, 1 000 ml, with aluminium-lined cap.
- 7.2 **Magnetic stirrer**, with stirring bars (size approximately 20 mm), glass, kept under the solvent used for extraction.
- 7.3 **Separating funnel**, capacity 1 000 ml, ISO 4800^[2], with PTFE stopcock and glass stopper.
- 7.4 **Conical flask**, nominal capacity 250 ml, with glass stopper.
- 7.5 **Equipment for concentrating the eluates by evaporation**, e.g. a rotary evaporator, regulatable for constant vacuum and with a temperature-controlled water bath, or stripping equipment using nitrogen gas.
- 7.6 **Microlitre syringes**, e.g. 500 μ l and 1 000 μ l.
- 7.7 **Reduction flask**, 100 ml (e.g. as shown in Figure C.3).
- 7.8 **Centrifuge with rotor**, with centrifuge tubes (e.g. as shown in Figure C.2) with tapered bottom, 50 ml.
- 7.9 **Shaking apparatus**, with adjustable rotational speed.
- 7.10 **Glass autosampler vials**, capacity e.g. 2 ml, with inert cap and PTFE-coated septum.
- 7.11 **Glass vials**, e.g. centrifuge tubes, graduated (scale division 0,1 ml), nominal capacity 10 ml, with glass stoppers.
- 7.12 **Gas chromatograph**, with mass spectrometric detector (EI).
- 7.13 **High resolution, low bleeding capillary column for gas chromatography** (e.g. see Annex A).

7.14 One-mark volumetric flasks, ISO 1042^[1], class A.

7.15 Microfilter, with solvent-resistant hydrophilic membrane, pore size 0,45 µm.

7.16 Pasteur pipettes.

7.17 Glass cartridges, filled with at least 0,5 g silica (see 7.18).

NOTE These cartridges are commercially available.

7.18 Silica, average particle size approximately 40 µm, heated at 450 °C for 3 h and stored in a desiccator to ensure maximum activity.

NOTE Pre-packed silica cartridges are commercially available.

7.19 Molecular sieve beads, pore diameter 0,4 nm.

7.20 Glass wool.

8 Sampling

Collect the sample in a glass bottle with a volume of 1 000 ml (7.1). Dechlorinate water samples containing chlorine by adding approximately 80 mg of sodium thiosulfate (6.1) prior to sample collection.

When sampling drinking water from a tap of the water supply, collect the sample before the tap is sterilized for bacteriological sampling by flame treatment.

NOTE Guidance on sampling programmes can be found in ISO 5667-1.

Fill the bottle to the shoulder (approximately 950 ml). Determine the volume of the sample to be extracted by weighing, before extraction and after emptying, with an accuracy of ±5 g. Store the sample between (3 ± 2) °C, protected from light, until the extraction is carried out (see also ISO 5667-3).

Ensure that the extraction is carried out within the maximum preservation time, as specified in ISO 5667-3, to avoid losses.

It is generally recommended that the extraction be carried out as soon as practicable to minimize potential adherence to glass which could be an issue when glassware is reused.

9 Procedure

9.1 General considerations

The extraction method shall not be used with samples containing more than 150 mg/l of suspended matter.

Volatile solvents other than hexane may be used if it is proven that there is equal or better recovery (recovery mass fraction between 70 % and 110 %).

9.2 Extraction

9.2.1 Sample preparation and extraction

Add a precisely defined amount of the internal standard (e.g a volume containing 50 ng), dissolved in a water-soluble solution (6.5.1). Add 25 ml of hexane (6.2.1), add a stirring bar (7.2) and close the flask (7.1) with an aluminium-lined cap or close the conical flask (7.4) with a ground stopper. Thoroughly mix the sample using the magnetic stirrer at maximum setting during 60 min. Transfer the sample to a separating funnel and allow the phases to separate for at least 5 min. If an emulsion is formed during the extraction process, collect

it in a centrifuge tube and centrifuge (7.8), for example for 10 min at about 3 000 r/min. Alternatively, a microseparator (see Annex B) can be used for separation of phases. Remove the separated water with a Pasteur pipette (7.16). Transfer the extract to a conical flask (7.4) and dry it according to 9.2.2. Be sure to rinse the bottle thoroughly with extraction solvent to extract any adsorbed PAH.

NOTE The extraction procedure can also be carried out in a separating funnel (7.3) using a shaking apparatus (7.9) and a microseparator (Annex C).

For the extraction of water samples with high concentrations of PAH, transfer only 10 ml to 100 ml of the homogeneous sample to a 250 ml conical flask (7.4) with a pipette and dilute with water to 200 ml. After adding 25 ml of hexane (6.2.1), proceed as above.

9.2.2 Drying of the extract

Transfer the hexane layer obtained in 9.2.1 into a 100 ml conical flask. Rinse the funnel or centrifuge tube with 5 ml of hexane and add it to the total extract.

Dry the extract with approximately 0,2 g sodium sulfate for at least 15 min, swirling the vessel frequently.

Decant the dry extract into a reduction flask (7.7). Rinse the conical flask twice with 5 ml of hexane and decant this also into the reduction flask.

9.2.3 Enrichment

Evaporate the dried hexane extract obtained in 9.2.2 until it fills only the tapered tip of the reduction flask (approximately 2 ml), e.g. using a rotary evaporator, at a temperature of 30 °C, slowly lowering the pressure to 20 kPa.

Do not evaporate the extracts to dryness, as losses of the 2- or 3-ring compounds can occur. Adding a few drops of decane (6.2.4) or isooctane (6.2.5) reduces the loss of the most volatile compounds.

Dissolve the extract into a known volume (e.g. 2 ml). Be sure that any residues that may be deposited on the glass wall are dissolved by shaking the extract using the shaking apparatus.

Clean the extracts of samples of unknown origin by silica clean-up according to 9.2.4 if the chromatogram shows interferences that hamper the quantification.

Transfer the enriched sample, if necessary after filtration through a microfilter (7.15), into a glass sample vial. Keep the sample in a cool and dark place until the analysis is carried out.

Proceed as specified in 9.4.

Alternative enrichment methods may be used. If a large volume injection is used or if higher concentrations of the target compounds are expected, a lower enrichment factor may be used.

9.2.4 Silica clean-up

For clean-up of the extract, use columns [Pasteur pipettes (7.16)] with a glass wool (7.20) plug or a cartridge (7.17) containing at least 0,5 g of silica (7.18). Clean the silica in the column or in the cartridge by rinsing with five bed volumes of a mixture of dichloromethane and hexane (1+1), followed by conditioning with the same volume of hexane (6.2.1).

NOTE 1 The clean-up is not possible for solutions that contain acetone.

Dry the solvents used for cleaning the extract by applying molecular sieve beads (7.19). The silica should have its maximum activity.

Concentrate the enriched extract (9.2.3) by blowing with a gentle stream of nitrogen (6.4.1), so that a volume of 500 µl remains.

Transfer the concentrated extract using a Pasteur pipette (7.16) on to the hexane-covered silica and allow to soak almost completely into the silica. Collect the eluate in a glass vial (7.11).

Rinse the reduction flask with 500 µl of hexane (6.2.1), add this solution on to the column, and allow to soak almost completely into the silica.

Elute the PAH with a mixture of dichloromethane and hexane (1+1).

NOTE 2 Commercially available cartridges containing 0,5 g of silica require a volume of at least 3 ml of the dichloromethane-hexane (1+1) mixture for the elution of the PAH.

Add a few drops of decane (6.2.4) or isooctane (6.2.5) to the eluate, homogenize by shaking, and enrich (see 9.2.3) to between 200 µl and 250 µl, e.g. first with a rotary evaporator (7.5) to about 2 ml, then with a stream of nitrogen (6.4.1).

Fill the extract up to a known volume (e.g. 2 ml) with the same solvent that has been used for the preparation of the calibration solutions (6.8).

Proceed as described in 9.4. Use an aliquot for the GC-MS determination.

9.3 Gas chromatography

Operate the gas chromatograph according to the manufacturer's instructions.

Select a capillary GC column and chromatographic conditions where efficient separation is achieved (e.g. see Annex A).

Analyse calibration solutions, blank and samples in the same conditions. If an injection standard (6.5.2) is used, add a precisely known amount of the injection standard to the calibration standards and extracts, mix thoroughly, and inject immediately in the GC.

9.4 Blank measurement

Perform blank determinations using water prior to and during series of analyses, at least one per batch. This water should be free of detectable PAH. Blank measurements shall include all steps of the analytical procedure from the sample arrival at the laboratory to the evaluation of the gas chromatogram. If blank values are unusually high (over 50 % of the lowest reporting level), every step in the procedure shall be checked in order to find the reason for these high blanks. Ensure that blanks are reduced as much as possible by various procedures, such as elimination of the contamination of the sample by ambient air and solvents, and checking of the analytical instrumentation.

If sample concentrations are close to the limit of quantification, however, blank values of higher than 50 % of the lowest reported value can be tolerated.

9.5 Mass spectrometric (MS) conditions

The mass spectrometer is adjusted in accordance with the manufacturer's instructions. Chromatograms are recorded in full scan (46 u to 300 u, where u is a unified atomic mass unit) or selected ion monitoring/recording mode (SIM/SIR).

Adjust the scan rate of the mass spectrometer to a velocity allowing one gas chromatographic peak to be described by at least seven data points.

A list of the diagnostic ions with relative intensities with reference to ISO 22892^[9] (GC-MS identification) are given in Table 4.

10 Calibration

10.1 General

A calibration curve encompassing the concentration range is prepared for each compound to be determined. The relative response, R_{rel} (see 10.2), or response factor, F_{R} (see 10.3), versus concentration in standard solutions is plotted or computed using a regression function. At least five calibration points are employed. See also ISO 8466-1.

10.2 Calibration by labelled internal standard

Labelled internal standard calibration is used for the PAH for which labelled compounds are added to samples.

Prepare a calibration curve encompassing the concentration range for each compound to be determined. Plot the relative response, R_{rel} (native to labelled), versus concentration in standard solutions or compute using a linear regression. Determine the relative response factor for each PAH in accordance with the procedures specified in the next paragraph. Employ at least five calibration points.

Determine the response of each PAH relative to its labelled analogue, R_{rel} , using the area responses of diagnostic ion 1:

$$R_{\text{rel}} = \frac{A_{1\text{n}} \rho_{\text{L}}}{A_{1\text{L}} \rho_{\text{n}}} \quad (1)$$

where

$A_{1\text{n}}$ is the area of diagnostic ion 1 for the PAH;

$A_{1\text{L}}$ is the area of diagnostic ion 1 for the labelled compound;

ρ_{L} is the concentration, in micrograms per litre, of the labelled compound in the calibration standard;

ρ_{n} is the concentration, in micrograms per litre, of the native compound in the calibration standard.

NOTE If the relative response for any compound is constant (less than 20 % coefficient of variation) over the five point calibration range, an averaged relative response can be used for that compound; otherwise the complete calibration curve for that compound can be used over the five point calibration range.

10.3 Calibration by internal standard

The internal standard method is applied to determination of other PAH for which no labelled standards have been added to the sample.

Calibration requires the determination of response factors, F_{R} , defined by Equation (2):

$$F_{\text{R}} = \frac{A_{1\text{s}} \rho_{\text{is}}}{A_{1\text{is}} \rho_{\text{s}}} \quad (2)$$

where

$A_{1\text{s}}$ is the area of diagnostic ion 1 for the PAH;

$A_{1\text{is}}$ is the area of diagnostic ion 1 for the internal standard;

ρ_{is} is the concentration, in micrograms per litre, of the internal standard;

ρ_{s} is the concentration, in micrograms per litre, of the compound in the calibration standard.

NOTE If the response factor, F_R , for any compound is constant (less than 20 % coefficient of variation) over the five point calibration range, an averaged response factor can be used for that compound; otherwise the complete calibration curve for that compound over the five point range can be used.

For the daily check of the calibration (recalibration), inject at least two calibration standards, e.g. at concentrations of 20 % \pm 10 % and 80 % \pm 10 % of the established linear range. Compare the calculated response factor with those obtained in the previous batch of samples. They should not differ more than 20 %.

11 Measurement of samples

Equilibrate the measuring system before measuring samples and adjust the mass spectrometer according to the manufacturer's instructions.

For the measurement, the following conditions shall apply.

Ionization method: electron impact.

Mass range of the spectrum: 46 u to 300 u, where u is a unified atomic mass unit, at least 10 u above the highest mass of the substances to be determined. With interferences, e.g. due to CO₂, the spectrum may be started at 46 u.

Cycle duration: so that at least seven spectra can be taken per substance peak.

If only single masses are registered in order to increase sensitivity, register the base peak and at least two more ions, with the same cycle duration as above.

12 Identification

The quantification of a single substance requires a secure and non-ambiguous identification. PAH have less fragmentation and therefore require additional criteria for identification.

When taking whole spectra, the sample spectrum and the reference spectrum taken under the same working conditions should be identical. The reference spectrum should be produced by each laboratory using their equipment and should be stored in a reference spectrum database. These spectra are to be used for identification purposes by mass spectrometry.

The deviation of the non-basic peak (not 100 % mass peak) should be less than 10 %.

If there is a shift of retention time, confirmation of identity can be done by spiking. The use of all 16 isotopically labelled PAH standards may be the best way to confirm the identity. See Table 3.

Table 3 — Degree of confirmation of the identity

Technique	Degree of identification	Operating mode	Additional criterion
MS	Possible	Single mass monitoring (SIM/SIR)	Compliance of the mass ratios with that of the standard compound within given limits
	Confirmed	Acquisition of total spectra (scan)	Compliance of the spectrum with that of the standard compound within given limits

A single substance is identified if:

- the relative retention time of a substance in the total ion current chromatogram of the sample does not differ by more than $\pm 0,2\%$ if the absolute retention time is greater than 500 s and less than 5 000 s;
- the relative intensity of the recorded diagnostic ions in the mass spectrum of the sample acquired under identical conditions does not differ by more than $\pm(0,1 I + 10)\%$ from those intensities of the reference substance. *I* is the relative intensity recorded from the characteristic ions in the mass spectrum of the reference solution.

Critical peak couples can lead to incorrect automatic assignments. In these cases, a manual check is essential. Critical peak couples are: phenanthrene-anthracene, benz[*a*]anthracene-chrysene, benzo[*b*]fluoranthene-benzo[*k*]fluoranthene and benzo[*a*]pyrene-benzo[*e*]pyrene.

Overlapping compounds with similar masses can be identified reliably only if the minimum between both peaks is not more than 25 % of the base peak; otherwise they are reported as a sum.

When using single masses, all mass signals listed in Table 4 should be present. The signal-to-noise ratio for the smallest peak of a mass should be over 3 ($S/N > 3$).

The ratio of the three masses in the spectrum should be determined from the peak heights at the peak maximum. The two non-100 % masses determined should, in relation to the 100 % mass, be within 10 % of the value determined under the same conditions with the reference material.

Table 4 — Characteristic masses of polycyclic aromatic hydrocarbons

Compound	CAS No.	Diagnostic ion ^a		
		1 <i>m/z</i>	2 <i>m/z</i>	3 <i>m/z</i>
Naphthalene	91-20-3	128 (100)	102 (11)	—
Acenaphthylene	208-96-8	152 (100)	150 (3)	76 (10)
Acenaphthene	83-32-9	153 (100)	154 (70)	76 (10)
Fluorene	86-73-7	165 (100)	166 (81)	139 (4)
Phenanthrene	85-01-8	178 (100)	152 (9)	76 (3)
Anthracene	120-12-7	178 (100)	152 (12)	76 (6)
Fluoranthene	206-44-0	202 (100)	200 (31)	100 (3)
Pyrene	129-00-0	202 (100)	200 (2)	101 (4)
Benzo[<i>a</i>]anthracene	56-55-3	228 (100)	226 (3)	114 (2)
Chrysene	218-01-9	228 (100)	226 (6)	113 (4)
Benzo[<i>b</i>]fluoranthene	205-99-2	252 (100)	250 (22)	126 (5)
Benzo[<i>k</i>]fluoranthene	207-08-9	252 (100)	250 (22)	126 (5)
Benzo[<i>a</i>]pyrene	50-32-8	252 (100)	250 (18)	113 (11)
Indeno[1,2,3- <i>cd</i>]pyrene	193-39-5	276 (100)	138 (12)	274 (4)
Dibenzo[<i>a,h</i>]anthracene	53-70-3	278 (100)	139 (9)	276 (5)
Benzo[<i>ghi</i>]perylene	191-24-2	276 (100)	138 (12)	274 (4)

^a Figures in italics indicate fragments that are often missing, while figures in parentheses are the relative intensities of the fragment ion.

The mass spectrum of the sample should include all ions that have a relative intensity of 10 % in the reference spectrum. The ratio of the intensities of the different ions in the sample spectrum and the reference spectrum should be within 20 %, tested on the three most important ions.

Single mass registration should be noted in the report.

For detection with mass spectrometry, use the peak area of the base peak of substance *i*, after checking the identity by comparison of the spectra, or, with the SIM technique, the isotope or fragment ratios. If using an internal standard, the reference is always the signal of the most intensive mass (main ion), after this signal has been checked for purity.

13 Calculation

13.1 Quantification by internal standards

Compute the concentrations of those PAH for which an internal standard is added using the response factors determined from the initial calibration data (10.3) and Equation (3), which gives the amount of the PAH in the extract, m_{ex} , in nanograms:

$$m_{\text{ex}} = \frac{A_{1\text{s}} m_{\text{is}}}{A_{1\text{is}} F_{\text{R}}} \quad (3)$$

where

$A_{1\text{s}}$ is the area of the diagnostic ion 1 for the PAH;

m_{is} is the amount, in nanograms, of the internal standard;

$A_{1\text{is}}$ is the area of the diagnostic ion 1 for the internal standard;

F_{R} is the response factor as defined in 10.3.

Determine the response factor of the internal standards relative to the injection standard using the area response of the diagnostic ion specified in Annex D. Using the amount in the extract determined by Equation (3), compute the recovery, w , expressed as a percentage mass fraction, of the internal standard compounds using Equation (4):

$$w = \frac{m_{\text{ex}}}{m_{\text{spk}}} \times 100 \% \quad (4)$$

where

m_{ex} is the amount, in nanograms, found;

m_{spk} is the amount, in nanograms, spiked.

For compounds for which no internal standard has been added, the recovery is determined as follows.

Add, for example, 2 ml of reference solutions prepared according to 6.5 to 1 000 ml water and proceed as specified in Clause 9.

Determine the recovery rates for surface water samples by the method of standard additions.

Determine the recovery of determinand *i* at the concentration level N , $w_{i,N}$, expressed as a mass fraction, using Equation (5):

$$w_{i,N} = \frac{\rho_{i,N_f}}{\rho_{i,N_e}} \quad (5)$$

Determine the mean recovery of determinand i , \bar{w}_i , expressed as a mass fraction, using Equation (6):

$$\bar{w}_i = \frac{\sum_{N=1}^n w_{i,N}}{n} \quad (6)$$

where

ρ_{i,N_f} is the found mass concentration, in micrograms per litre, of determinand i at concentration level N , calculated using the calibration function;

ρ_{i,N_e} is the given mass concentration, in micrograms per litre, of determinand i at concentration level N ;

n is the number of concentration levels.

13.2 Quantification by labelled internal standards and labelled compound recovery

By adding a known amount of a labelled compound to every sample prior to extraction, correction for recovery can be made because the PAH and its labelled analogue exhibit similar effects upon extraction, concentration, and gas chromatography. Use relative response, R_{rel} , values in conjunction with the initial calibration data specified in 10.2 to determine concentrations directly, as long as labelled compound spiking levels are constant, using Equation (7) to give the amount, m_{ex} , in nanograms, of the PAH in the extract:

$$m_{ex} = \frac{A_{1n} m_L}{A_{1L} R_{rel}} \quad (7)$$

where

A_{1n} is the area of the diagnostic ion 1 for the native compound;

A_{1L} is the area of the diagnostic ion 1 for the labelled compound;

m_L is the amount, in nanograms, of the labelled compound in the calibration standard;

R_{rel} is the relative response as defined in 10.2.

Determine the recovery rates for surface water and waste water samples by the method of standard additions.

Determine the recovery of determinand i at the concentration level N , $w_{i,N}$, expressed as a percentage mass fraction, using Equation (8):

$$w_{i,N} = \frac{\rho_{i,N_f}}{\rho_{i,N_e}} \times 100 \% \quad (8)$$

Determine the mean recovery of the determinand i , \bar{w}_i , expressed as a percentage mass fraction, using Equation (9):

$$\bar{w}_i = \frac{\sum_{N=1}^n w_{i,N}}{n} \times 100 \% \quad (9)$$

where

ρ_{i,N_f} is the found mass concentration, in micrograms per litre, of determinand i at concentration level N , calculated with the calibration function;

ρ_{i,N_e} is the given mass concentration, in micrograms per litre, of determinand i at concentration level N ;

n is the number of concentration levels.

13.3 Recovery of internal standards

Recoveries of the internal standards (ISO 7981-2^[4]) for most samples are similar to those from reagent water.

If the internal standard recovery is outside these ranges, a diluted sample shall be analysed.

If the recovery of any of the internal standards in the diluted sample is outside the normal range, the calibration solutions (6.8) shall be analysed and the calibration shall be verified. For each compound, confirm that the result of the verification analysis is within 20 % of the nominal concentration. If, however, any compound falls outside its respective limit, the measurement system is not performing properly for that compound. In this event, prepare a fresh calibration standard or correct the problem causing the failure and repeat the tuning of the mass spectrometer (9.5) and verification test or recalibrate (10.2).

13.4 Concentration in the sample

Compute the concentration of a PAH in the aqueous phase of the sample, ρ , in micrograms per litre, as follows:

$$\rho = \frac{m_{\text{ex}}}{V_{\text{s}}} \quad (10)$$

where

m_{ex} is the amount, in micrograms, of the compound in the extract;

V_{s} is the sample volume, in litres.

14 Expression of results

Report the mass concentration of PAH in micrograms per litre, to not more than two significant figures. Concentrations <0,01 µg/l are rounded to the nearest 0,001 µg/l.

EXAMPLES:

Measured value	Result
13,54 µg/l	14 µg/l
1,354 µg/l	1,4 µg/l
0,135 4 µg/l	0,14 µg/l
0,013 5 µg/l	0,014 µg/l
0,008 5 µg/l	0,008 µg/l

15 Test report

This test report shall contain at least the following information:

- a) the test method used, with reference to this International Standard (ISO 28540:2011);
- b) all information necessary for the complete identification of the sample;
- c) relevant information about the sampling method used and sample preservation;
- d) the concentration of each of the PAH, expressed in accordance with Clause 14;
- e) if used, a note on single mass registration during MS analysis;
- f) all operating details not specified in this International Standard, or regarded as optional, together with details of any incidents which may have influenced the test results.

Annex A (informative)

Examples for GC-MS conditions

Table A.1 — Examples of chromatographic conditions

Column	Dimensions: length inner diameter film thickness	Temperature program
95 % dimethylpolysiloxane 5 % diphenylpolysiloxane	30 m 0,25 mm 0,25 µm	40 °C, 8 min isothermal 5 °C/min to 310 °C 15 min isothermal
86 % dimethylpolysiloxane 14 % cyanopropylene-polysiloxane	30 m 0,25 mm 1,0 µm	40 °C, 6 min isothermal 5 °C/min to 220 °C 4 min isothermal

Annex B (informative)

Precision and accuracy

Statistical data obtained from liquid-liquid extraction (LLE) results of an interlaboratory trial carried out in 2009 are given in Tables B.1, B.2, and B.3.

Table B.1 — Drinking water (LLE) statistical data

Analyte	Percentage of outliers	No. laboratories after outlier rejection	Assigned value	Overall mean	Reproducibility standard deviation	Coefficient of variation of reproducibility ^a	Coefficient of variation of repeatability
	o %	l	ρ_{ass} ng/l	$\bar{\rho}$ ng/l	s_R ng/l	$C_{V,R}$ %	$C_{V,r}$ %
Acenaphthene	16,67	15	10,1	11,77	5,11	43,40	7,60
Acenaphthylene	33,33	12	10,1	9,3	3,14	33,70	7,40
Anthracene	22,22	14	10,1	8,6	3,2	37,10	8,30
Benzo[a]anthracene	22,22	14	10,5	9,73	3,13	32,10	7,00
Benzo[a]pyrene	26,32	14	9,9	8,66	3,29	38,00	7,60
Benzo[b]fluoranthene	21,05	15	10,1	8,82	2,32	26,30	11,20
Benzo[ghi]perylene	21,05	15	10,3	8,58	2,14	24,90	13,20
Benzo[k]fluoranthene	21,05	15	10,2	8,9	2,3	25,90	8,70
Chrysene	26,32	14	10,1	9,7	3,57	36,80	7,20
Dibenzo[a,h]anthracene	31,58	13	10,3	8,3	2,45	29,50	14,00
Fluoranthene	27,78	13	10	10,54	3,2	30,40	7,70
Fluorene	16,67	15	10,1	10,81	3,31	30,60	8,50
Indeno[1,2,3-cd]pyrene	26,32	14	10,5	8,08	2,62	32,40	12,80
Naphthalene	21,05	15	10,3	12,06	4,81	39,90	10,60
Phenanthrene	22,22	14	10,1	12,29	7,25	58,90	7,30
Pyrene	27,78	13	10,2	10,12	2,67	26,40	8,00

^a $C_{V,R} > 40\%$ means that validation of this parameter was not successful.

Table B.2 — Natural (river) (LLE) water statistical data

Analyte	Percentage of outliers o %	No. laboratories after outlier rejection l	Assigned value ρ_{ass} ng/l	Overall mean $\bar{\rho}$ ng/l	Reproducibility standard deviation s_R ng/l	Coefficient of variation of reproducibility ^a $C_{V,R}$ %	Coefficient of variation of repeatability $C_{V,r}$ %
Acenaphthene	11,1	16	44,5	30,74	12,73	41,40	5,00
Acenaphthylene	16,7	15	44,5	29,15	11,98	41,10	7,30
Anthracene	5,6	17	44,6	28,31	14,42	50,90	9,90
Benzo[a]anthracene	15,8	16	46,1	27,19	13,56	49,90	6,50
Benzo[a]pyrene	10,5	17	43,6	30,33	13,88	45,80	8,20
Benzo[b]fluoranthene	15,8	16	44,5	34,04	13,79	40,50	6,90
Benzo[ghi]perylene	15,8	16	45,2	26,85	9,56	35,60	8,30
Benzo[k]fluoranthene	21,1	15	44,8	23,63	7,94	33,60	5,40
Chrysene	10,5	17	44,6	30,33	15,14	49,90	7,10
Dibenzo[a,h]anthracene	10,5	17	45,1	24,58	10,18	41,40	10,70
Fluoranthene	11,1	16	43,8	35,59	12,46	35,00	7,90
Fluorene	5,6	17	44,4	31,37	14,19	45,20	6,90
Indeno[1,2,3-cd]pyrene	15,8	16	46,2	25,69	11,96	46,60	7,50
Naphthalene	10,5	17	45,5	27,54	15,87	57,60	6,70
Phenanthrene	27,8	13	44,4	30,17	16,83	55,80	5,60
Pyrene	10,5	17	44,7	38,58	14,38	37,30	7,60

^a $C_{V,R} > 40\%$ means that validation of this parameter was not successful.

Table B.3 — Waste water (LLE) statistical data

Analyte	Percentage of outliers	No. laboratories after outlier rejection	Assigned value	Overall mean	Reproducibility standard deviation	Coefficient of variation of reproducibility ^a	Coefficient of variation of repeatability
	<i>o</i> %		<i>l</i>	ρ_{ass} ng/l			
Benzo[a]anthracene	27,8	13	101	70,53	46,93	66,50	10,10
Benzo[a]pyrene	29,4	12	95,5	58,59	40,82	69,70	10,10
Benzo[b]fluoranthene	29,4	12	97,6	82,41	56,72	68,80	10,30
Benzo[ghi]perylene	31,3	11	99,1	62,73	44	70,10	10,00
Benzo[k]fluoranthene	17,6	14	98,2	57,47	40,63	70,70	15,50
Chrysene	27,8	13	97,9	66,8	45,06	67,50	11,90
Dibenzo[a,h]anthracene	23,5	13	98,9	45,28	28,53	63,00	12,90
Fluoranthene	27,8	13	96,1	83,43	56,77	68,00	10,00
Fluorene	0,0	18	97,4	73,39	37,77	51,50	10,80
Indeno[1,2,3-cd]pyrene	31,3	11	101,3	65,24	49,19	75,40	9,90
Naphthalene	11,8	15	99,7	35,11	11,34	32,30	6,70
Phenanthrene	27,8	13	97,4	79,09	50,94	64,40	8,50
Pyrene	22,2	14	98,1	87,04	56,94	65,40	9,80

^a $C_{V,R} > 40\%$ means that validation of this parameter was not successful.

Annex C (informative)

Examples of the construction of special apparatus

See Figures C.1 to C.3.

Dimensions in millimetres

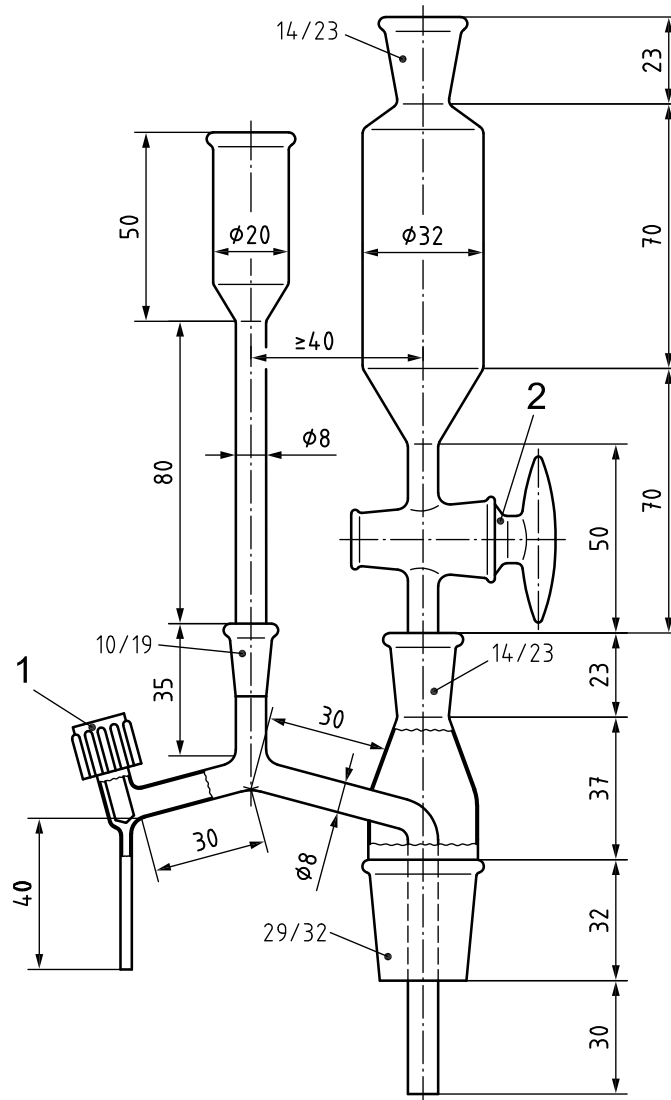

Key

- 1 PTFE screw cock
- 2 PTFE stopcock

Figure C.1 — Microseparator

Dimensions in millimetres

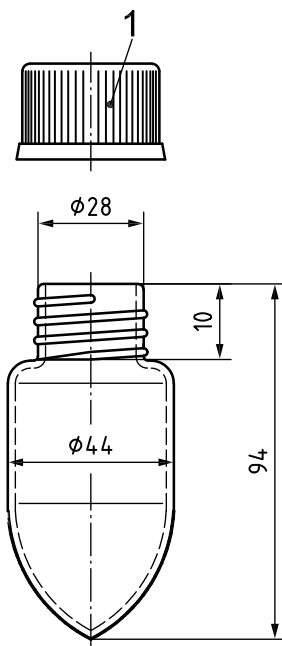

Key

- 1 aluminium-lined screw cap

Figure C.2 — Centrifuge tube with tapered bottom and screw cap

Dimensions in millimetres

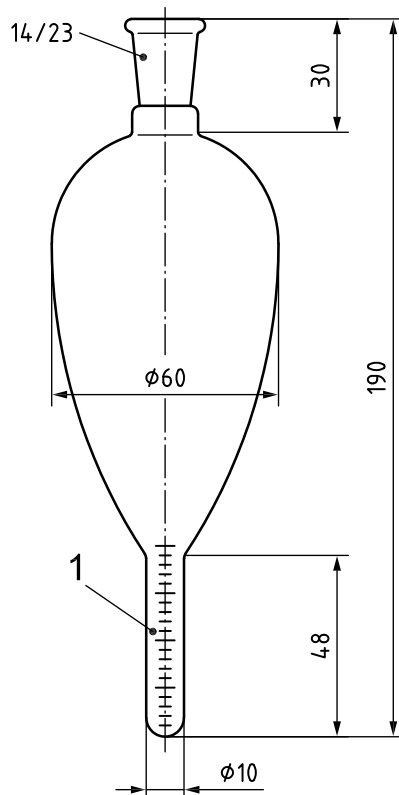

Key

- 1 total volume 2 ml with graduations of 0,1 ml

Figure C.3 — Reduction flask

Annex D (informative)

Example of chromatograms

See Figure D.1 and Table D.1.

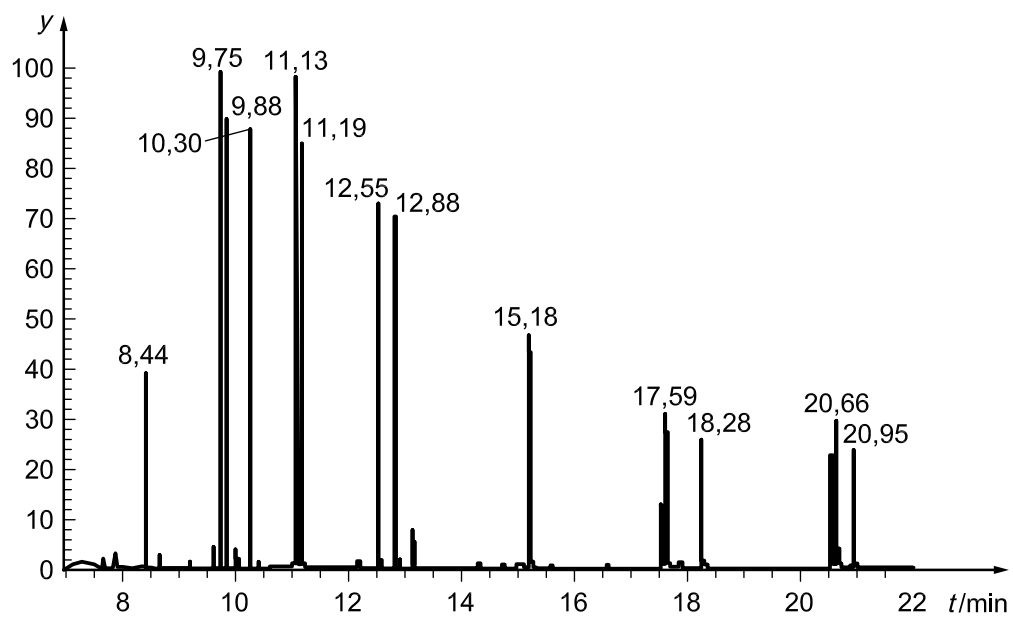

a)

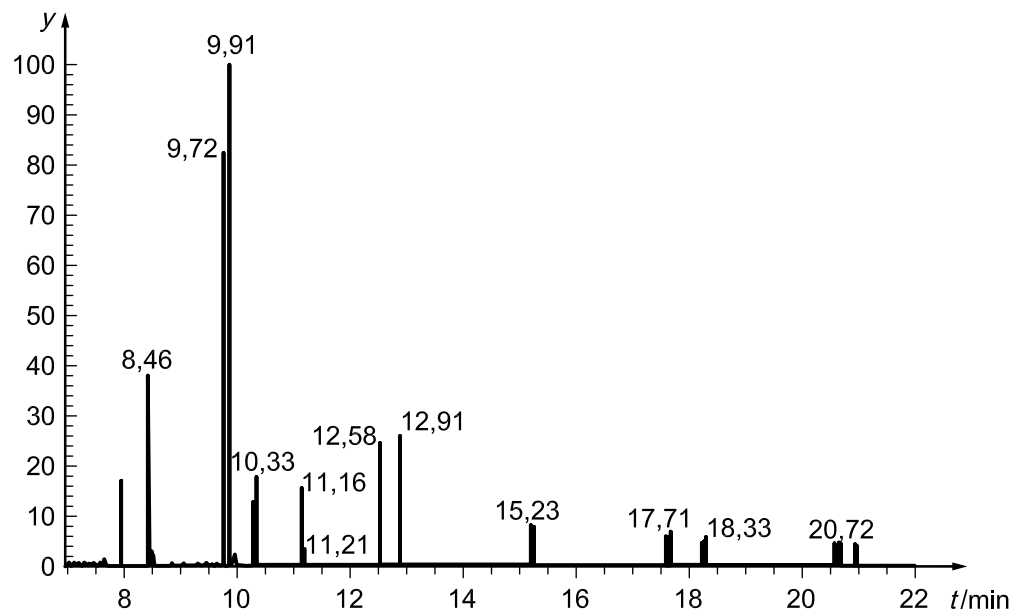

b)

Key

y relative abundance

t time

Figure D.1 — Typical example of chromatograms

Table D.1 — Results

Component [Figure D.1 b)]	Retention time <i>t</i>	Component [Figure D.1 a)]	Retention time <i>t</i>
Naphthalene	8,46	Naphthalene-d8	8,44
Acenaphthylene	9,72	Acenaphthylene-d8	9,75
Acenaphthene	9,91	Acenaphthene-d10	9,88
Fluorene	10,33	Fluorene-d10	10,30
Phenanthrene	11,16	Phenanthrene-d10	11,13
Anthracene	11,21	Anthracene-d10	11,19
Fluoranthene	12,58	Fluoranthene-d10	12,55
Pyrene	12,91	Pyrene-d10	12,88
Benzo[a]anthracene	15,23	Benzo[a]anthracene-d12	15,18
Chrysene	15,30	Chrysene-d12	15,24
Benzo[b]fluoranthene	17,64	Benzo[b]fluoranthene-d12	17,59
Benzo[k]fluoranthene	17,71	Benzo[k]fluoranthene-d12	17,66
Benzo[a]pyrene	18,33	Benzo[a]pyrene-d12	18,28
Indeno[1,2,3- <i>cd</i>]pyrene	20,62	Indeno[1,2,3- <i>cd</i>]pyrene-d12	20,58
Dibenzo[<i>a,h</i>]anthracene	20,72	Dibenzo[<i>a,h</i>]anthracene-d14	20,66
Benzo[<i>ghi</i>]perylene	20,99	Benzo[<i>ghi</i>]perylene-d12	20,95

Annex E (informative)

Extraction with extraction disks

E.1 Extraction with extraction disks

E.1.1 Sample preparation and extraction

In general, samples are examined without pretreatment, i.e. suspended particulate matter is not removed prior to analysis. Do not filter the sample.

Add a precisely defined amount of the internal standard, e.g. 50 ng, dissolved in an appropriate solvent (6.5.1).

E.1.2 Conditioning of adsorbent disks

Add 4 ml of acetone (6.2.3) and let it pass through the cartridge in about 20 s, e.g. using a vacuum device. Ensure that the adsorbent does not run dry.

Repeat this step once.

Add 4 ml of water and let it pass through the cartridge in about 20 s, e.g. using a vacuum device. Ensure that the adsorbent does not run dry.

Repeat this step once.

E.1.3 Extraction and elution

Take, for example, 1 000 ml of the sample to be examined and pass it through the adsorbent conditioned as in E.1.2 at a flow rate of about 50 ml/min. Rinse the sample reservoir (e.g. the sample bottle) with 4 ml of water and pass it through the adsorbent as described in E.1.2. Dry the adsorbent in a stream of nitrogen (6.4.1) for not less than 7 min.

Elute in three steps as follows.

- Step 1: Add 3 ml of acetone (6.2.3), allowing 1 min for the solvent to soak. Collect the eluate by passing it through the cartridge in about 20 s.
- Step 2: Add 3 ml of acetone (6.2.3), allowing 5 min for the solvent to soak. Collect the eluate by passing it through the cartridge in about 20 s.
- Step 3: Repeat step 1.

Collect the combined eluates in a glass vessel. No extract-drying step is necessary, as long as acetone (6.2.3) is used for extraction.

NOTE Other volatile solvents (e.g. hexane containing a volume fraction of 5 % ethyl acetate) may be used for extraction and elution as long as it is proved that there is equal or better recovery (recovery between 70 % and 110 %).

If necessary, carefully evaporate the solvent and concentrate the eluate as specified in 9.2.3.

Proceed as specified in 9.3. Use an aliquot for the GC-MS determination.

Bibliography

- [1] ISO 1042, *Laboratory glassware — One-mark volumetric flasks*
- [2] ISO 4800, *Laboratory glassware — Separating funnels and dropping funnels*
- [3] ISO 7981-1, *Water quality — Determination of polycyclic aromatic hydrocarbons (PAH) — Part 1: Determination of six PAH by high-performance thin-layer chromatography with fluorescence detection after liquid-liquid extraction*
- [4] ISO 7981-2, *Water quality — Determination of polycyclic aromatic hydrocarbons (PAH) — Part 2: Determination of six PAH by high-performance liquid chromatography with fluorescence detection after liquid-liquid extraction*
- [5] ISO 15089:2000, *Water quality — Guidelines for selective immunoassays for the determination of plant treatment and pesticide agents*
- [6] ISO 17858:2007, *Water quality — Determination of dioxin-like polychlorinated biphenyls — Method using gas chromatography/mass spectrometry*
- [7] ISO 17993, *Water quality — Determination of 15 polycyclic aromatic hydrocarbons (PAH) in water by HPLC with fluorescence detection after liquid-liquid extraction*
- [8] ISO 18073:2004, *Water quality — Determination of tetra- to octa-chlorinated dioxins and furans — Method using isotope dilution HRGC/HRMS*
- [9] ISO 22892:2006, *Soil quality — Guidelines for the identification of target compounds by gas chromatography and mass spectrometry*
- [10] COUNCIL OF THE EUROPEAN UNION. Council Directive 98/83/EC of 3 November 1998 on the quality of water intended for human consumption. *Off. J.* 1998, **L330**, pp. 32-54
- [11] WERRES, F., BALSAA, P. and SCHMIDT, T.C. Total concentration analysis of polycyclic aromatic hydrocarbons in aqueous samples with high suspended particulate matter content. *J. Chromatogr. A* 2009, **1216**, pp. 2235-2240

British Standards Institution (BSI)

BSI is the national body responsible for preparing British Standards and other standards-related publications, information and services.

BSI is incorporated by Royal Charter. British Standards and other standardization products are published by BSI Standards Limited.

About us

We bring together business, industry, government, consumers, innovators and others to shape their combined experience and expertise into standards-based solutions.

The knowledge embodied in our standards has been carefully assembled in a dependable format and refined through our open consultation process. Organizations of all sizes and across all sectors choose standards to help them achieve their goals.

Information on standards

We can provide you with the knowledge that your organization needs to succeed. Find out more about British Standards by visiting our website at bsigroup.com/standards or contacting our Customer Services team or Knowledge Centre.

Buying standards

You can buy and download PDF versions of BSI publications, including British and adopted European and international standards, through our website at bsigroup.com/shop, where hard copies can also be purchased.

If you need international and foreign standards from other Standards Development Organizations, hard copies can be ordered from our Customer Services team.

Subscriptions

Our range of subscription services are designed to make using standards easier for you. For further information on our subscription products go to bsigroup.com/subscriptions.

With **British Standards Online (BSOL)** you'll have instant access to over 55,000 British and adopted European and international standards from your desktop. It's available 24/7 and is refreshed daily so you'll always be up to date.

You can keep in touch with standards developments and receive substantial discounts on the purchase price of standards, both in single copy and subscription format, by becoming a **BSI Subscribing Member**.

PLUS is an updating service exclusive to BSI Subscribing Members. You will automatically receive the latest hard copy of your standards when they're revised or replaced.

To find out more about becoming a BSI Subscribing Member and the benefits of membership, please visit bsigroup.com/shop.

With a **Multi-User Network Licence (MUNL)** you are able to host standards publications on your intranet. Licences can cover as few or as many users as you wish. With updates supplied as soon as they're available, you can be sure your documentation is current. For further information, email bsmusales@bsigroup.com.

BSI Group Headquarters

389 Chiswick High Road London W4 4AL UK

Revisions

Our British Standards and other publications are updated by amendment or revision.

We continually improve the quality of our products and services to benefit your business. If you find an inaccuracy or ambiguity within a British Standard or other BSI publication please inform the Knowledge Centre.

Copyright

All the data, software and documentation set out in all British Standards and other BSI publications are the property of and copyrighted by BSI, or some person or entity that owns copyright in the information used (such as the international standardization bodies) and has formally licensed such information to BSI for commercial publication and use. Except as permitted under the Copyright, Designs and Patents Act 1988 no extract may be reproduced, stored in a retrieval system or transmitted in any form or by any means – electronic, photocopying, recording or otherwise – without prior written permission from BSI. Details and advice can be obtained from the Copyright & Licensing Department.

Useful Contacts:

Customer Services

Tel: +44 845 086 9001

Email (orders): orders@bsigroup.com

Email (enquiries): cservices@bsigroup.com

Subscriptions

Tel: +44 845 086 9001

Email: subscriptions@bsigroup.com

Knowledge Centre

Tel: +44 20 8996 7004

Email: knowledgecentre@bsigroup.com

Copyright & Licensing

Tel: +44 20 8996 7070

Email: copyright@bsigroup.com



...making excellence a habit.™