

Road vehicles — Securing of cargo in delivery vans — Requirements and test methods

ICS 43.020

National foreword

This British Standard is the UK implementation of ISO 27956:2009.

The UK participation in its preparation was entrusted to Technical Committee AUE/7, Automobile occupant restraint systems.

A list of organizations represented on this committee can be obtained on request to its secretary.

This publication does not purport to include all the necessary provisions of a contract. Users are responsible for its correct application.

Compliance with a British Standard cannot confer immunity from legal obligations.

This British Standard was published under the authority of the Standards Policy and Strategy Committee on 31 October 2009

© BSI 2009

ISBN 978 0 580 62792 7

Amendments/corrigenda issued since publication

Date	Comments

INTERNATIONAL STANDARD

ISO
27956

First edition
2009-03-15

Road vehicles — Securing of cargo in delivery vans — Requirements and test methods

*Véhicules routiers — Arrimage des charges à bord des camionnettes
de livraison — Exigences et méthodes d'essai*



Reference number
ISO 27956:2009(E)

PDF disclaimer

This PDF file may contain embedded typefaces. In accordance with Adobe's licensing policy, this file may be printed or viewed but shall not be edited unless the typefaces which are embedded are licensed to and installed on the computer performing the editing. In downloading this file, parties accept therein the responsibility of not infringing Adobe's licensing policy. The ISO Central Secretariat accepts no liability in this area.

Adobe is a trademark of Adobe Systems Incorporated.

Details of the software products used to create this PDF file can be found in the General Info relative to the file; the PDF-creation parameters were optimized for printing. Every care has been taken to ensure that the file is suitable for use by ISO member bodies. In the unlikely event that a problem relating to it is found, please inform the Central Secretariat at the address given below.



COPYRIGHT PROTECTED DOCUMENT

© ISO 2009

All rights reserved. Unless otherwise specified, no part of this publication may be reproduced or utilized in any form or by any means, electronic or mechanical, including photocopying and microfilm, without permission in writing from either ISO at the address below or ISO's member body in the country of the requester.

ISO copyright office
Case postale 56 • CH-1211 Geneva 20
Tel. + 41 22 749 01 11
Fax + 41 22 749 09 47
E-mail copyright@iso.org
Web www.iso.org

Published in Switzerland

Contents

Page

Foreword.....	iv
1 Scope	1
2 Terms and definitions.....	1
3 Requirements	2
3.1 General requirements	2
3.2 Partitioning system.....	2
3.3 Lashing points	4
4 Test methods.....	8
4.1 Static load tests of the partitioning system	8
4.2 Testing of the strength of the lashing point	10
Bibliography	13

Foreword

ISO (the International Organization for Standardization) is a worldwide federation of national standards bodies (ISO member bodies). The work of preparing International Standards is normally carried out through ISO technical committees. Each member body interested in a subject for which a technical committee has been established has the right to be represented on that committee. International organizations, governmental and non-governmental, in liaison with ISO, also take part in the work. ISO collaborates closely with the International Electrotechnical Commission (IEC) on all matters of electrotechnical standardization.

International Standards are drafted in accordance with the rules given in the ISO/IEC Directives, Part 2.

The main task of technical committees is to prepare International Standards. Draft International Standards adopted by the technical committees are circulated to the member bodies for voting. Publication as an International Standard requires approval by at least 75 % of the member bodies casting a vote.

Attention is drawn to the possibility that some of the elements of this document may be the subject of patent rights. ISO shall not be held responsible for identifying any or all such patent rights.

ISO 27956 was prepared by Technical Committee ISO/TC 22, *Road vehicles*, Subcommittee SC 12, *Passive safety crash protection systems*.

Road vehicles — Securing of cargo in delivery vans — Requirements and test methods

1 Scope

This International Standard applies to vehicle-relevant equipment for the securing of cargo in delivery vans with a gross vehicle mass up to 7,5 t. This International Standard specifies minimum requirements and test methods for securing cargo in a reliable and roadworthy way, in order to protect occupants against injuries caused by shifting cargo.

This International Standard deals with N1 vehicles and N2 vehicles up to 7,5 t in accordance with ECE classification¹⁾. For vehicles primarily designed for the transportation of cargo and derived from a passenger vehicle (M1), only the requirements concerning the partitioning system of this International Standard apply.

NOTE Extreme loads (e.g. vehicle impacts) that can occur during an accident are outside the scope of this International Standard.

2 Terms and definitions

For the purposes of this document, the following terms and definitions apply.

2.1

delivery van

vehicle for the transport of cargo, of which the occupant compartment and loading space form one unit

2.2

lashing point

attachment part on the vehicle or an integrated device, to which **lashing devices** (2.3) can be connected in a form-fit manner and designed to transfer the lashing forces to the vehicle structure

NOTE An integrated device can be, for example, a ring, a loop, a tie-down, a hook, an eye, a lug, a hook-in edge, a thread connection, or rails.

2.3

lashing device

device that is designed to be attached to the **lashing points** (2.2) in order to secure the cargo on the vehicle and that consists of a tensioning device, a tensioning element and connections, if required

NOTE 1 A tensioning device can be, for example, a belt or a strap.

NOTE 2 A tensioning element can be, for example, a wrench, a ratchet, or a spanner.

NOTE 3 Connections can be, for example, a hook or an eyelet.

1) See Reference [1].

2.4 partitioning system

device that fully or partially separates the occupant compartment from the loading space

EXAMPLE Partition, bulkhead, grid.

2.5 protection zone

area behind each seating position, for which special requirements for the protection against shifting cargo apply, limited to the area of vertical longitudinal sections, symmetrical to the left and right of the relevant R-points, with a width of 544 mm per seat and extending over the entire height of the occupant compartment

NOTE 1 In the case of a bench, the protection zones between the R-points can overlap.

NOTE 2 See ISO 6549 for further information on R-points.

2.6 roadworthy

design concept aiming at excluding harm to occupants of a road vehicle travelling on public roads under normal conditions of operation, such as full braking, emergency braking, braking in a curve, fast lane changing and driving in a curve

NOTE The concept of "harm" includes injuries and fatality.

3 Requirements

3.1 General requirements

In order to prevent cargo from penetrating into the occupant compartment, delivery vans shall be equipped with adequate devices to protect the occupants against the cargo. Therefore, protection devices consisting of a **partitioning system** (see 2.4) and **lashing points** (see 2.2) shall be provided.

3.2 Partitioning system

The **partitioning system** (see 2.4) shall fully separate the occupant compartment from the loading space, in terms of width and height. In the case of a loading space above the occupant compartment, the partitioning system may be limited in height to the horizontal separation between the occupant compartment and that loading space. However, in the case of a vehicle having a driver seat only and no passenger seat, the partitioning system does not need to cover the entire width of the vehicle, provided that the driver's **protection zone** (see 2.5) is covered and, in addition, the driver seating position is sufficiently protected against laterally shifting cargo.

If there is a gap between the partitioning system and the vehicle body this shall not be more than 40 mm (see Figure 2) without removing the covering (or trim), if any. A larger value is permissible in the case of corrugations in the side walls, as well as in order to ensure proper deployment of curtain airbags, if fitted.

If the partitioning system consists of a grid or cargo net, a rigid test device (e.g. rod), having a front surface of (50 × 10) mm moved in longitudinal direction (parallel to the x-axis of the vehicle), shall not be able to pass such nets or grids in any orientation (rotation around the x-axis).

The strength of the entire partitioning system shall be tested in accordance with 4.1.2. The **protection zone(s)** (see 2.5) of the partitioning system shall withstand testing in accordance with 4.1.3.

Each point within the protection zones shall meet the requirements of a test using the type 2 plunger piston (see 4.1.3). If windows or a door are located in the protection zone, such elements shall also withstand this test. The window material may fracture, as long as the deformation criteria given below are met.

Permanent deformations of the partitioning system up to 300 mm (see Figure 1) are permissible when tested in accordance with 4.1.2 or 4.1.3, as long as such deformations do not cause sharp edges or other deformations which might result directly or indirectly in injuries to the occupants.

Dimensions in millimetres

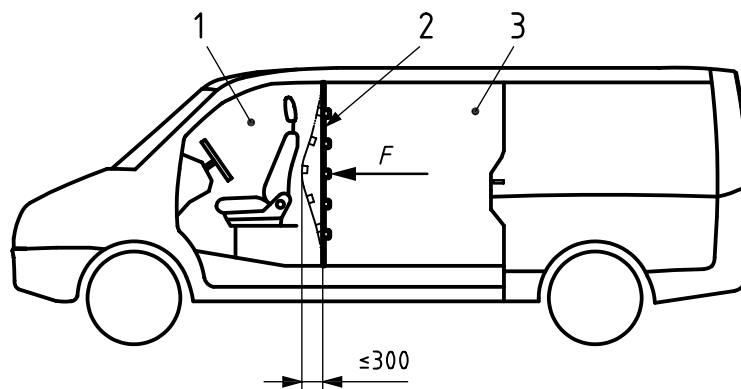

Key

- 1 occupant compartment
- 2 partitioning system
- 3 loading space
- F* test force

Figure 1 — Partitioning system

Dimensions in millimetres

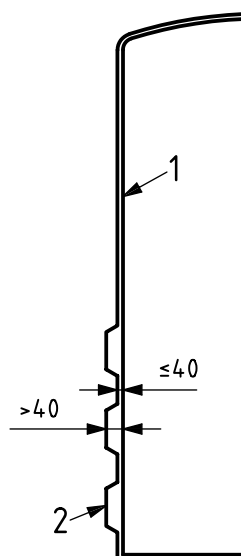

Key

- 1 partitioning system
- 2 corrugation in side wall

Figure 2 — Detail of partitioning system

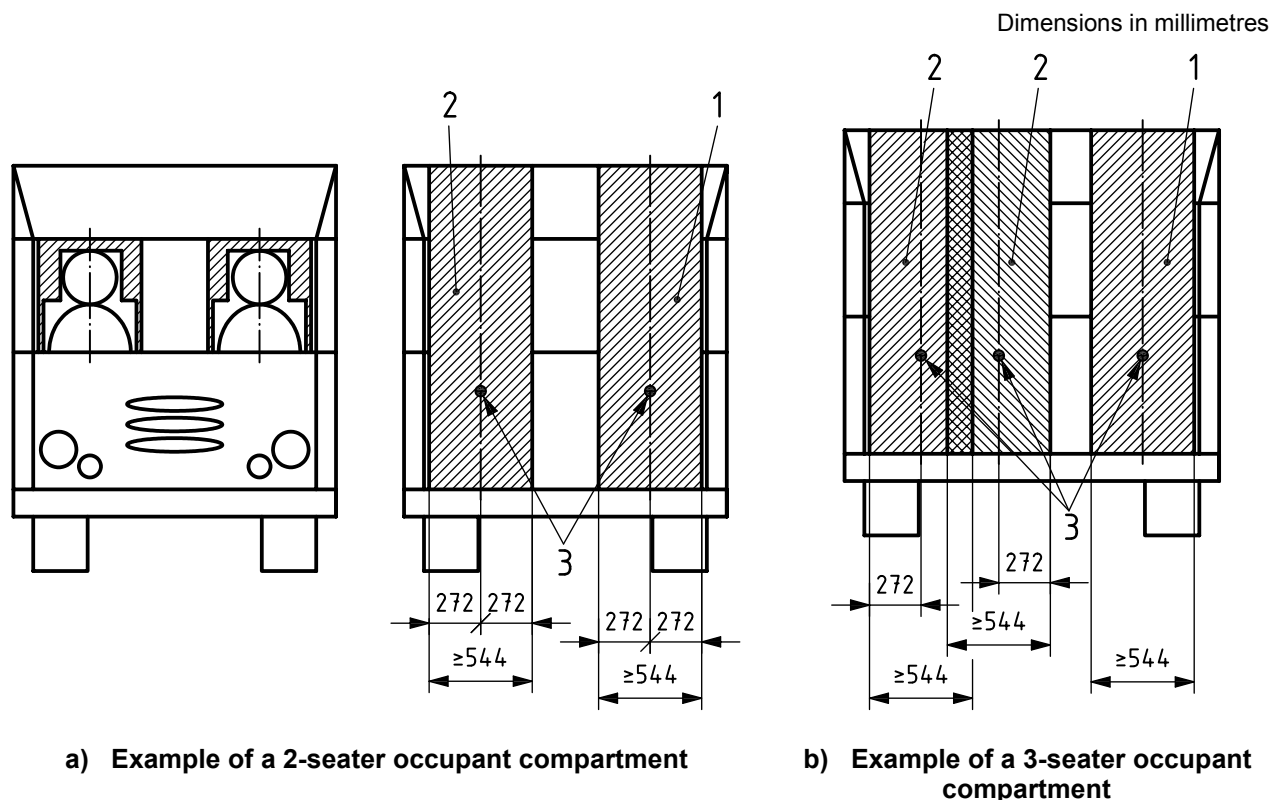

Key

- 1 driver's protection zone
- 2 passenger's protection zone
- 3 R-point

Figure 3 — Protection zones

3.3 Lashing points

3.3.1 General

The loading space of delivery vans shall be equipped with lashing points.

3.3.2 Design

3.3.2.1 The geometry of the lashing points is not specified in this International Standard, but is decided by the vehicle manufacturer. Examples of typical designs of lashing points are shown in Figure 4. Whatever design is selected by the vehicle manufacturer, the clearance of the lashing point shall be such that it shall be possible to insert through the opening of the lashing point a cylindrical probe with a diameter, d_1 , as specified in Table 1.

Table 1

Diameter of cylindrical probe to be inserted d_1 mm	Gross vehicle mass m_{GVM} t
35	$5,0 < m_{GVM} \leq 7,5$
25	$2,5 < m_{GVM} \leq 5,0$
20	$m_{GVM} \leq 2,5$

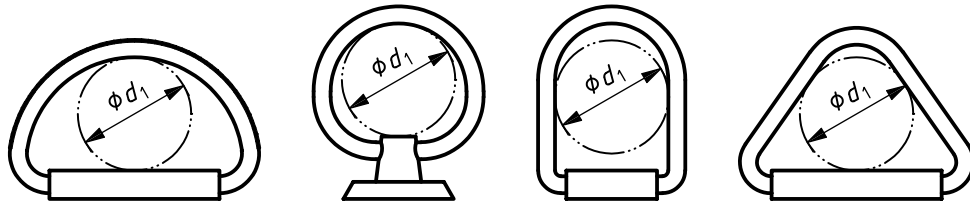

Key

d_1 diameter of cylindrical probe to be inserted

Figure 4 — Examples of typical designs of lashing points

3.3.2.2 The maximum cross section of the loop/ring must not be greater than 18 mm (see Figure 5). If the lashing point consists of a different design or other dimension, the vehicle manufacturer shall provide the adequate fastening elements.

Dimensions in millimetres

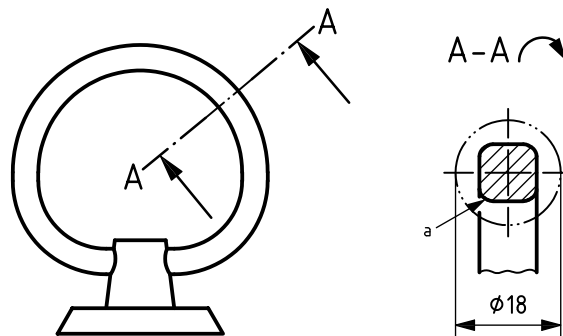

Key

^a Cross section ≤ 18 mm.

Figure 5 — Maximum cross section of lashing loops/rings

3.3.3 Strength of lashing points

3.3.3.1 Each lashing point shall be designed for one of the categories of nominal tension force, F_N , calculated in accordance with Table 2, and shall withstand the test force applied under any angle in the range between 0° and 60° to the vertical (see Figure 12) during the test specified in 4.2.1.

3.3.3.2 The strength of the lashing points is proven if the tests specified in 4.2.1 are passed.

Table 2

Nominal tension force F_N kN	Gross vehicle mass m_{GVM} t
$F_N = 1/4 m_P \times g$, but $3,5 < F_N \leq 8$	$5,0 < m_{GVM} \leq 7,5$
$F_N = 1/3 m_P \times g$, but $3,5 < F_N \leq 5$	$2,5 < m_{GVM} \leq 5,0$
$F_N = 1/2 m_P \times g$, but $3 < F_N \leq 4$	$m_{GVM} \leq 2,5$
m_P is the maximum payload, in kg.	
g is the acceleration of gravity ($9,81 \text{ m/s}^2$).	

3.3.4 Number and alignment of lashing point pairs

3.3.4.1 Lashing points shall be located on the floor and/or side walls, as closely as possible to the floor, but not more than 150 mm above the floor of the loading area. The lashing points should be arranged in pairs, located opposite each other and distributed as evenly as possible alongside the loading area.

3.3.4.2 The number and alignment of lashing point pairs is influenced by the following parameters:

- the maximum spacing between lashing points in longitudinal direction (see 3.3.4.3);
- the length of the loading area (see 3.3.4.4).

3.3.4.3 The lashing point pairs shall be aligned as follows (see Figure 6):

- a) the recommended longitudinal spacing, L_S , between two lashing point pairs is $L_S \leq 700 \text{ mm}$; however, in any case, $L_S \leq 1\,200 \text{ mm}$;
- b) the longitudinal distance from the front and rear boundary of the usable loading space shall be not more than 250 mm;
- c) the lateral distance from the side boundary of the usable loading space shall be not more than 150 mm.

Dimensions in millimetres

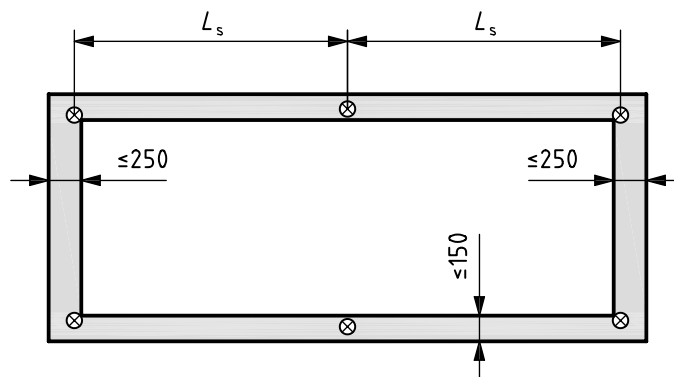

Key

L_S recommended longitudinal spacing

Figure 6 — Alignment of lashing point pairs

3.3.4.4 For vehicles having a loading area up to 1 300 mm in length, at least two pairs of lashing points shall be provided (two lashing points at each side).

The minimum number, N , of pairs of lashing points shall be based on the length, L , in millimetres, of the loading space (measured on the floor at $y = 0$) and shall be calculated by taking into account the distances of 250 mm (see 3.3.4.3) and 800 mm spacing, as shown in Equation (1):

$$N = \frac{L - (2 \times 250)}{800} + 1 \quad (1)$$

The calculated result shall be rounded up or down in accordance with conventional rounding rules, i.e.

- decimals in the range between $x,01$ and $x,49$ shall be rounded down;
- decimals in the range between $x,50$ and $x,99$ shall be rounded up.

EXAMPLE A delivery van having a length of the loading space of 2 550 mm:

$$N = \frac{2\,550 - (2 \times 250)}{800} + 1$$

$$N = 2,56 + 1$$

$$N = 3,56$$

$$N = 4 \text{ pairs of lashing points}$$

3.3.5 Consumer information

Information on the maximum strength, in kN, of each lashing point in the vehicle shall be provided in the owner's manual. In addition, a label should be used inside the cargo compartment (see Figure 7). This label shall be inscribed with white letters on a blue background with a white border. The label should be fixed in the loading space in a position that is clearly visible (e.g. near to the door) and that is normally not covered by the load. The minimum size of the label is (100 × 130) mm.

Dimensions in millimetres

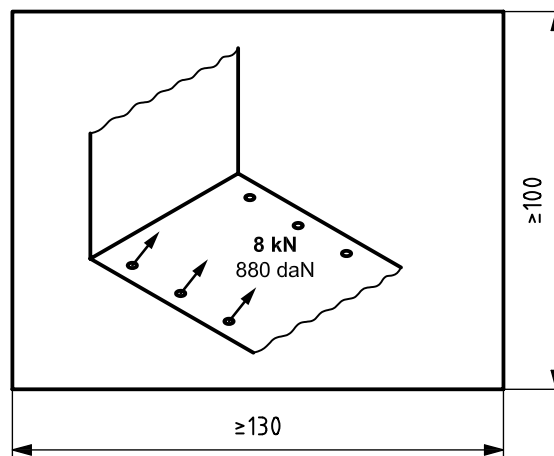

NOTE The strength values shown are given as an example only.

Figure 7 — Example of labelling of lashing points

4 Test methods

4.1 Static load tests of the partitioning system

4.1.1 Plunger pistons

4.1.1.1 Type 1

The type 1 plunger piston shall be applied for testing the entire partitioning system and its fixation to the vehicle body (see Figure 8). The type 1 plunger piston shall have a flat square surface with a 1 000 mm side length and an edge radius ≤ 20 mm.

In the case of delivery vans where the opening of the rear loading door and/or the geometry of the partitioning system do not permit the installation of the type 1 piston, a reduced type 1 plunger piston with the maximum possible rectangular geometry should be used (see Figure 9).

Dimensions in millimetres

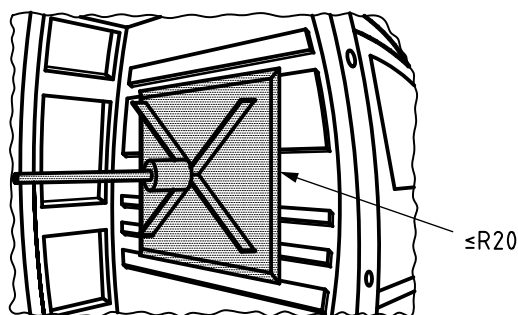

Figure 8 — Type 1 plunger piston



Figure 9 — Reduced type 1 plunger piston

4.1.1.2 Type 2

The type 2 plunger piston (see Figure 10) shall have a flat square surface with a 50 mm side length and an edge radius $\leq 0,5$ mm. This type of plunger piston shall be applied only within the area of the **protection zones** (see 2.5).

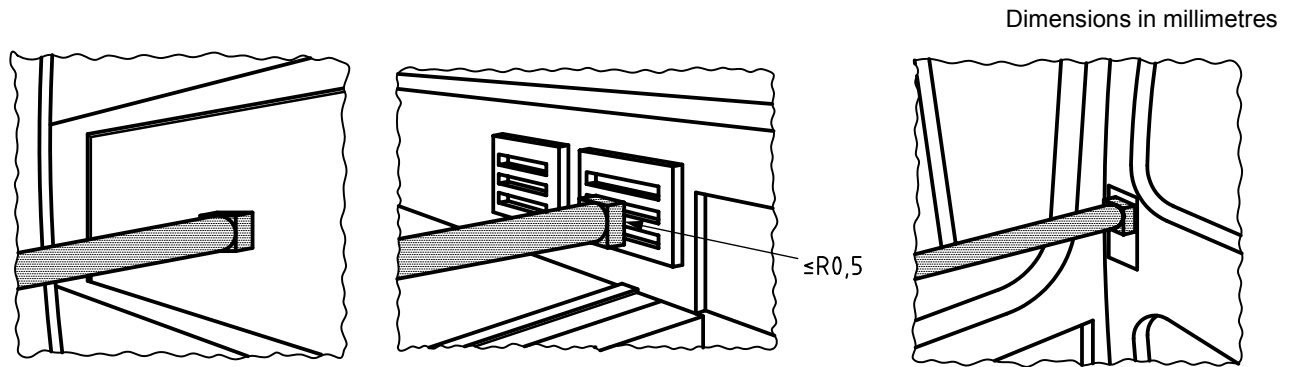

Figure 10 — Type 2 plunger piston

4.1.1.3 Attachment

For the tests described in 4.1.2 and 4.1.3, the partitioning device should be tested when it is installed into the specific vehicle or into the Body in White to make sure that the fitting conditions represent the original situation. If the test is not carried out in a vehicle or in a Body in White, the partitioning system shall be attached to a rigid frame with its attachment hardware. The rigid frame shall incorporate a rigid horizontal plane which replicates the general level of the vehicle floor. The attachment points shall replicate the geometry of the intended vehicle anchorages.

If there are different installation locations inside a vehicle type, the worst-case position shall be chosen.

4.1.1.4 Use of adapters

For the tests described in 4.1.2 and 4.1.3, the use of adapters to evenly distribute the pressure to the partition is permitted, if necessary (e.g. in the case of cranked partitions).

4.1.2 Tests using the type 1 plunger piston

The entire retaining device with its fixation is tested by using a type 1 plunger piston, as described in 4.1.1.1. The plunger piston shall be applied to the centre of the partitioning system (based on its height and width).

The test force, F , shall be calculated using Equation (2) below. This test force acts horizontally in the longitudinal direction on the partitioning system. The test force should be increased as quickly as possible, without exceeding 2 s, and shall be maintained for 10 s.

$$F = 0,5 \times m_p \times g \quad (2)$$

where

F is the test force, in N;

m_p is the maximum payload, in kg;

g is the acceleration of gravity (9,81 m/s²).

4.1.3 Tests using the type 2 plunger piston

With a type 2 plunger piston, as described in 4.1.1.2, any point of the retaining device within the **protection zones** (see 2.5) may be selected for testing.

The test force, F , shall be calculated using Equation (3) below, but it should not exceed 10 kN. This test force acts horizontally in the longitudinal direction on the partitioning system. The test force should be increased as quickly as possible, without exceeding 2 s, and shall be maintained for 10 s.

$$F = 0,3 \times m_P \times g \quad (3)$$

In the case of grids, the type 2 plunger piston shall be applied to the points where the bars crisscross.

4.2 Testing of the strength of the lashing point

4.2.1 Test procedure

A representative body structure shall be used for the test. Adapters may be used to distribute the force into the lashing point system evenly. Any lashing point in the vehicle may be selected for testing. The lashing point shall be loaded with a lashing device suitable for the test. The test force shall be applied at an angle of up to 60° measured to the vertical line (see Figure 12), towards an opposed lashing point. Any reaction forces, if induced into the vehicle structure by the test equipment, should be applied with a distance of at least 300 mm to the lashing point under test. However, this distance shall not be less than 100 mm. Testing shall be conducted in accordance with the following four-step procedure described below.

— **Step 1:**

- apply a pre-load of 5 % of the nominal tension force, F_N ;
- set the deformation measurement system to zero.

— **Step 2:**

- increase the load within 20 s up to F_N ;
- hold the load for at least 30 s;
- release the load to zero;
- reload the system up to the pre-load;
- measure the permanent deformation of the lashing point (including the vehicle structure) at the point of force application: the test is passed if permanent deformation is ≤ 12 mm (measured in the direction of force application).

— **Step 3:**

- apply again within 20 s a load equivalent to F_N ;
- hold the load for at least 30 s;
- release the load to zero;
- reload the system up to the pre-load;
- measure the permanent deformation: the test is passed if the limit specified in step 2 is not exceeded.

— **Step 4:**

- increase the load within 25 s up to a force of $1,25 \times F_N$;
- hold the load for at least 30 s;
- release the load to zero;
- the test is passed if the function of the lashing point remains intact; additional permanent deformation is permissible.

The relevant parameters of this four-step procedure are summarized in Figure 11. The measuring principle for determination of the permanent deformation is shown in Figure 12.

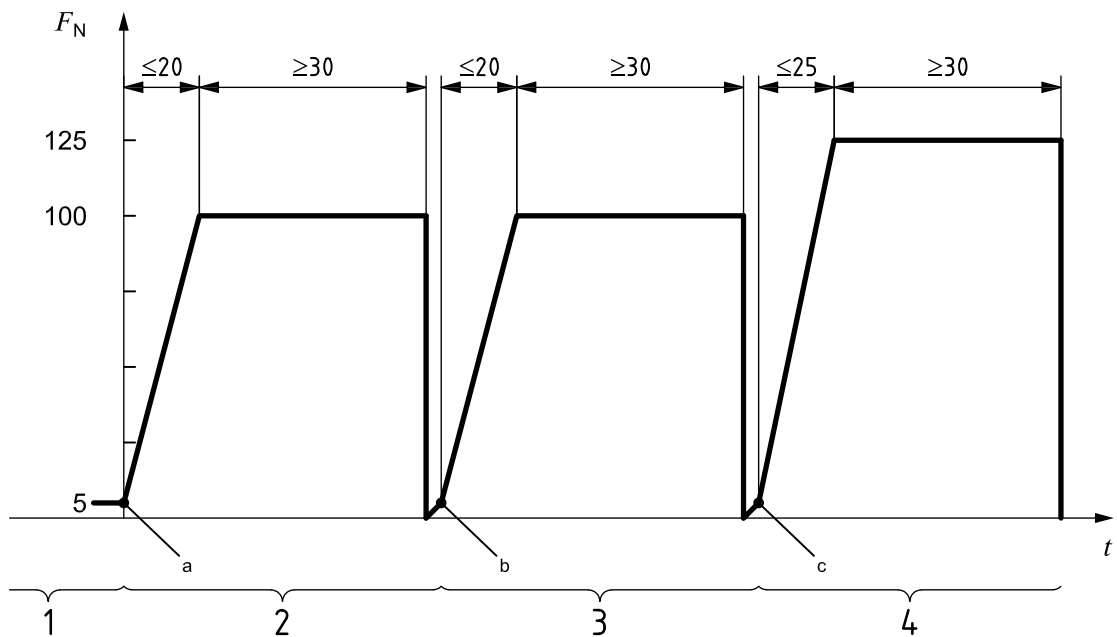

Key

- 1 step 1
- 2 step 2
- 3 step 3
- 4 step 4
- a Set deformation to zero.
- b First deformation measurement.
- c Second deformation measurement.

F_N nominal tension force, in %

t time, in s

Figure 11 — Main parameters of the four-step procedure for testing lashing points

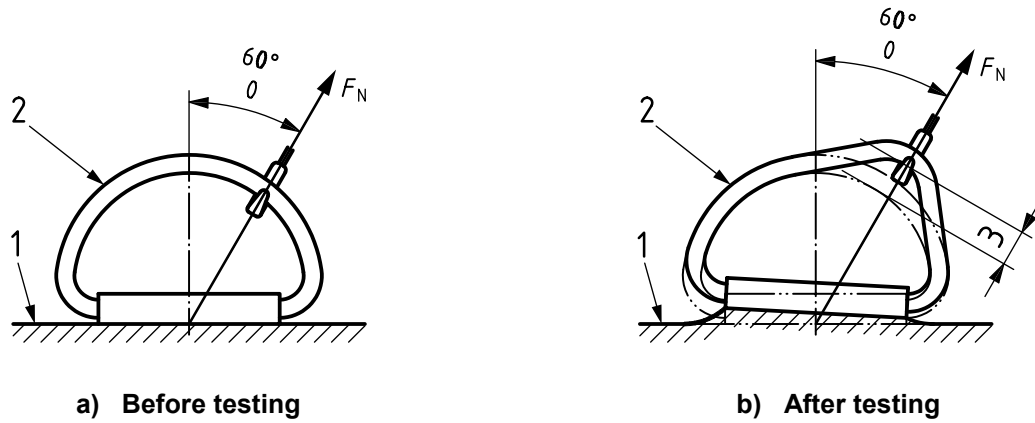

Key

- 1 floor of loading area
- 2 lashing point under test
- 3 point and direction of measurement of maximum permanent deformation

F_N nominal tension force

Figure 12 — Testing of lashing points

4.2.2 Calculation

Testing is not required provided the vehicle manufacturer can demonstrate that the calculation used to verify the performance of the lashing points is equivalent to the testing.

Bibliography

- [1] UNECE TRANS/WP.29/78/Rev.1/Amd.2, 16 April 1999, Consolidated Resolution on the Construction of Vehicles (R.E.3)
- [2] ISO 6549, *Road vehicles — Procedure for H- and R-point determination*
- [3] EN 12195-1, *Load restraint assemblies on road vehicles — Safety — Calculation of lashing forces*
- [4] EN 12195-2, *Load restraint assemblies on road vehicles — Safety — Web lashing made from man-made fibres*
- [5] EN 12195-3, *Load restraint assemblies on road vehicles — Safety — Lashing chains*
- [6] EN 12640, *Securing of cargo on road vehicles — Lashing points on commercial vehicles for goods transportation — Minimum requirements and testing*
- [7] VDI 2700, *Securing of loads on road vehicles*

BSI - British Standards Institution

BSI is the independent national body responsible for preparing British Standards. It presents the UK view on standards in Europe and at the international level. It is incorporated by Royal Charter.

Revisions

British Standards are updated by amendment or revision. Users of British Standards should make sure that they possess the latest amendments or editions.

It is the constant aim of BSI to improve the quality of our products and services. We would be grateful if anyone finding an inaccuracy or ambiguity while using this British Standard would inform the Secretary of the technical committee responsible, the identity of which can be found on the inside front cover. Tel: +44 (0)20 8996 9000. Fax: +44 (0)20 8996 7400.

BSI offers members an individual updating service called PLUS which ensures that subscribers automatically receive the latest editions of standards.

Buying standards

Orders for all BSI, international and foreign standards publications should be addressed to Customer Services. Tel: +44 (0)20 8996 9001. Fax: +44 (0)20 8996 7001 Email: orders@bsigroup.com You may also buy directly using a debit/credit card from the BSI Shop on the Website <http://www.bsigroup.com/shop>

In response to orders for international standards, it is BSI policy to supply the BSI implementation of those that have been published as British Standards, unless otherwise requested.

Information on standards

BSI provides a wide range of information on national, European and international standards through its Library and its Technical Help to Exporters Service. Various BSI electronic information services are also available which give details on all its products and services. Contact Information Centre. Tel: +44 (0)20 8996 7111 Fax: +44 (0)20 8996 7048 Email: info@bsigroup.com

Subscribing members of BSI are kept up to date with standards developments and receive substantial discounts on the purchase price of standards. For details of these and other benefits contact Membership Administration. Tel: +44 (0)20 8996 7002 Fax: +44 (0)20 8996 7001 Email: membership@bsigroup.com

Information regarding online access to British Standards via British Standards Online can be found at <http://www.bsigroup.com/BSOL>

Further information about BSI is available on the BSI website at <http://www.bsigroup.com>

Copyright

Copyright subsists in all BSI publications. BSI also holds the copyright, in the UK, of the publications of the international standardization bodies. Except as permitted under the Copyright, Designs and Patents Act 1988 no extract may be reproduced, stored in a retrieval system or transmitted in any form or by any means – electronic, photocopying, recording or otherwise – without prior written permission from BSI.

This does not preclude the free use, in the course of implementing the standard, of necessary details such as symbols, and size, type or grade designations. If these details are to be used for any other purpose than implementation then the prior written permission of BSI must be obtained.

Details and advice can be obtained from the Copyright and Licensing Manager. Tel: +44 (0)20 8996 7070 Email: copyright@bsigroup.com