

BS ISO 27850:2013



BSI Standards Publication

# Tractors for agriculture and forestry — Falling object protective structures — Test procedures and performance requirements

**bsi.**

...making excellence a habit.™

**National foreword**

This British Standard is the UK implementation of ISO 27850:2013.

The UK participation in its preparation was entrusted to Technical Committee AGE/6, Agricultural tractors and forestry machinery.

A list of organizations represented on this committee can be obtained on request to its secretary.

This publication does not purport to include all the necessary provisions of a contract. Users are responsible for its correct application.

© The British Standards Institution 2013. Published by BSI Standards Limited 2013

ISBN 978 0 580 66292 8

ICS 65.060.10

**Compliance with a British Standard cannot confer immunity from legal obligations.**

This British Standard was published under the authority of the Standards Policy and Strategy Committee on 30 June 2013.

**Amendments issued since publication**

Date	Text affected
------	---------------

---

---

---

**Tractors for agriculture and  
forestry — Falling object protective  
structures — Test procedures and  
performance requirements**

*Tracteurs agricoles et forestiers — Structures de protection contre les  
chutes d'objets — Modes opératoires d'essai et exigences de performance*





**COPYRIGHT PROTECTED DOCUMENT**

© ISO 2013

All rights reserved. Unless otherwise specified, no part of this publication may be reproduced or utilized otherwise in any form or by any means, electronic or mechanical, including photocopying, or posting on the internet or an intranet, without prior written permission. Permission can be requested from either ISO at the address below or ISO's member body in the country of the requester.

ISO copyright office  
Case postale 56 • CH-1211 Geneva 20  
Tel. + 41 22 749 01 11  
Fax + 41 22 749 09 47  
E-mail [copyright@iso.org](mailto:copyright@iso.org)  
Web [www.iso.org](http://www.iso.org)

Published in Switzerland

# Contents

Page

<b>Foreword</b> .....	<b>iv</b>
<b>Introduction</b> .....	<b>v</b>
<b>1 Scope</b> .....	<b>1</b>
<b>2 Normative references</b> .....	<b>1</b>
<b>3 Terms and definitions</b> .....	<b>1</b>
<b>4 Permissible measurement tolerances</b> .....	<b>2</b>
<b>5 Procedure</b> .....	<b>2</b>
5.1 Preparation of tractor and FOPS for testing.....	2
5.2 Apparatus and procedure.....	4
<b>6 Performance requirements</b> .....	<b>8</b>
<b>7 Cold weather performance of protective structures</b> .....	<b>8</b>
<b>8 Labelling</b> .....	<b>8</b>
<b>9 Test report</b> .....	<b>9</b>
<b>Annex A (normative) Optional requirements for providing resistance to brittle fracture of falling-object protective structures (FOPS) at reduced operation temperature</b> .....	<b>10</b>
<b>Annex B (normative) Test report for falling-object protective structures (FOPS)</b> .....	<b>12</b>
<b>Annex C (informative) Designation of Maintenance Agency</b> .....	<b>16</b>
<b>Bibliography</b> .....	<b>17</b>

## Foreword

ISO (the International Organization for Standardization) is a worldwide federation of national standards bodies (ISO member bodies). The work of preparing International Standards is normally carried out through ISO technical committees. Each member body interested in a subject for which a technical committee has been established has the right to be represented on that committee. International organizations, governmental and non-governmental, in liaison with ISO, also take part in the work. ISO collaborates closely with the International Electrotechnical Commission (IEC) on all matters of electrotechnical standardization.

The procedures used to develop this document and those intended for its further maintenance are described in the ISO/IEC Directives, Part 1. In particular the different approval criteria needed for the different types of ISO documents should be noted. This document was drafted in accordance with the editorial rules of the ISO/IEC Directives, Part 2. [www.iso.org/directives](http://www.iso.org/directives)

Attention is drawn to the possibility that some of the elements of this document may be the subject of patent rights. ISO shall not be held responsible for identifying any or all such patent rights. Details of any patent rights identified during the development of the document will be in the Introduction and/or on the ISO list of patent declarations received. [www.iso.org/patents](http://www.iso.org/patents)

Any trade name used in this document is information given for the convenience of users and does not constitute an endorsement.

The committee responsible for this document is ISO/TC 23, *Tractors and machinery for agriculture and forestry*, Subcommittee SC 2, *Common tests*.

This first edition of ISO 27850 has been developed to establish technical harmonization with OECD Code 10: July 2012.

## Introduction

The falling-object protective structure (FOPS) testing procedure considered in this International Standard refers to the tractor used in its traditional agricultural tasks. However, it is reasonable to consider that a specific use of the tractor, such as dedicated forestry applications, for which the tractor has to be properly equipped, would need FOPS testing at higher levels of energy, for which other test methods are appropriate.

This International Standard specifies technical performance requirements, associated test procedures, and performance test report information. Technical harmonization with OECD Code 10 is ensured by the Maintenance Agency operating as specified in [Annex C](#).





# Tractors for agriculture and forestry — Falling object protective structures — Test procedures and performance requirements

## 1 Scope

This International Standard sets forth the test procedures and performance requirements for a falling-object protective structure, in the event such a structure is installed on an agricultural or forestry tractor.

This International Standard is applicable to agricultural and forestry tractors having at least two axles for pneumatic tyred wheels or having tracks instead of wheels.

This International Standard does not apply to forestry machinery as defined in ISO 6814.

## 2 Normative references

The following documents, in whole or in part, are normatively referenced in this document and are indispensable for its application. For dated references, only the edition cited applies. For undated references, the latest edition of the referenced document (including any amendments) applies.

ISO 3164:1995, *Earth-moving machinery — Laboratory evaluations of protective structures — Specifications for deflection-limiting volume*

ISO 3463:2006, *Tractors for agriculture and forestry — Roll-over protective structures (ROPS) — Dynamic test method and acceptance conditions*

ISO 3471:2008, *Earth-moving machinery — Roll-over protective structures — Laboratory tests and performance requirements*

ISO 5700:2013, *Tractors for agriculture and forestry — Roll-over protective structures (ROPS) — Static test method and acceptance conditions*

ISO 12003-1:2008, *Agricultural and forestry tractors — Roll-over protective structures on narrow-track wheeled tractors — Part 1: Front-mounted ROPS*

ISO 12003-2:2008, *Agricultural and forestry tractors — Roll-over protective structures on narrow-track wheeled tractors — Part 2: Rear-mounted ROPS*

ASTM A370:1979, *Standard Test Methods and Definitions for Mechanical Testing of Steel Products*

## 3 Terms and definitions

For the purposes of this document, the following terms and definitions apply.

### 3.1

#### **agricultural tractor**

self-propelled agricultural vehicle having at least two axles, or a track-laying agricultural vehicle, and having a maximum design speed of not less than 6 km/h, particularly designed to pull, push, carry, and operate implements used for agricultural work (including forestry work), which may be provided with a detachable loading platform

Note 1 to entry: It may be equipped with one or more seats.

**3.2**  
**falling-object protective structure**  
**FOPS**

assembly providing reasonable overhead protection to an operator in driving position from falling objects

**3.3**  
**roll-over protective structure**  
**ROPS**

framework (safety cab or frame) protecting operators of agricultural and forestry tractors that avoids or limits risk to the operator resulting from accidental overturning during normal operation

Note 1 to entry: The ROPS is characterized by the provision of space for a clearance zone, either inside the envelope of the structure or within a space bounded by a series of straight lines from the outer edges of the structure to any part of the tractor that might come into contact with flat ground and that is capable of supporting the tractor in that position if the tractor overturns.

**3.4**  
**safety zone**

zone of protection provided for the tractor operator

Note 1 to entry: The safety zone is determined by the ROPS International Standard that has been chosen. For tractors equipped with ROPS tested in accordance with ISO 3463, ISO 5700, ISO 12003-1, or ISO 12003-2, the safety zone is the clearance zone specified in each of these International Standards. For tractors equipped with ROPS tested in accordance with ISO 3471, the safety zone is the deflection limiting volume (DLV) according to ISO 3164.

## **4 Permissible measurement tolerances**

- a) Distance  $\pm 5\%$  of maximum deflection or  $\pm 1$  mm
- b) Mass  $\pm 0,5\%$

## **5 Procedure**

### **5.1 Preparation of tractor and FOPS for testing**

**5.1.1** Whether the FOPS is manufactured by the tractor manufacturer or by an independent party, the test shall only be valid for the model of tractor on which the test is carried out. The FOPS shall be retested for each model of tractor to which it is to be fitted. However, the testing station may certify that the strength tests are also valid for tractor models derived from the original model by modifications to the engine, transmission, and steering and front suspension (see [Clause 9](#)). On the other hand, more than one FOPS may be tested for any one model of tractor.

**5.1.2** The protective structure submitted for test shall include at least all components which transfer loading from the impact location of the drop test object to the safety zone. The protective structure submitted for test shall be either (i) rigidly attached to the test bench at its normal mounting locations (see [Figure 1](#)), or (ii) attached to the tractor chassis in the normal manner, by means of any brackets, mountings, or suspension components used in normal production and other parts of the tractor that may be affected by loads imposed by the protective structure [see [Figures 2a](#)] and [2b](#)]. The vehicle chassis shall be mounted rigidly to the test bay floor.

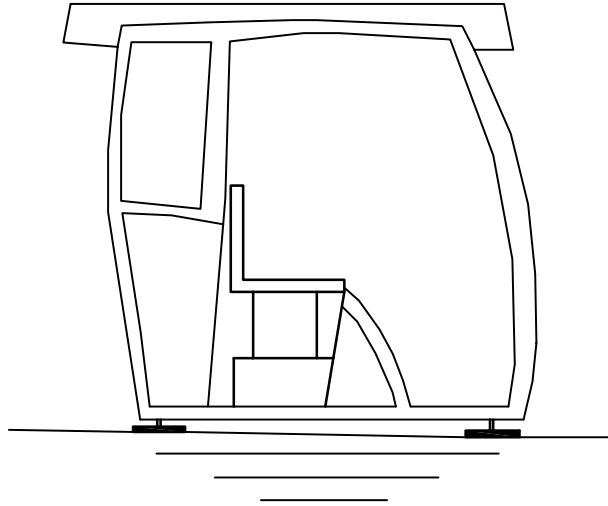

**Figure 1 — Minimum test configuration**

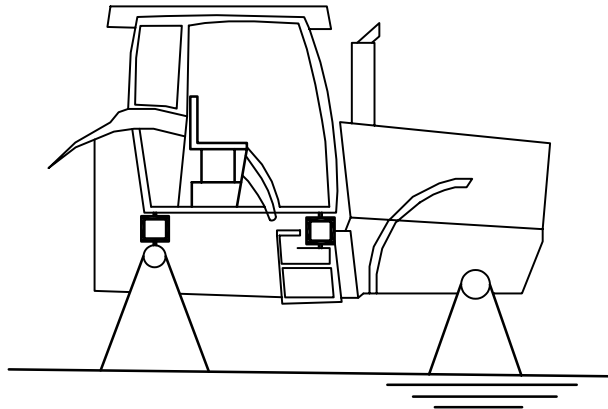

**a) By mountings/attachments**

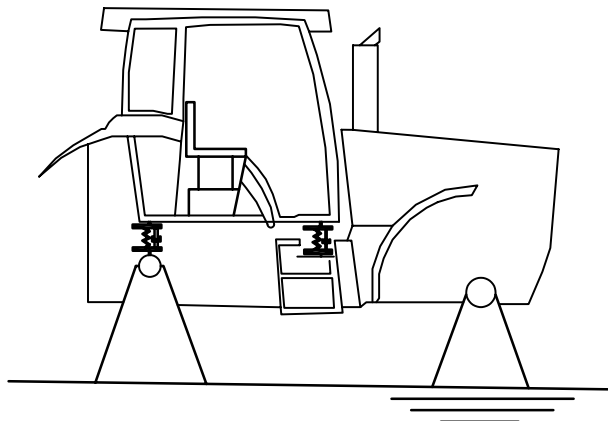

**b) By suspension components**

**Figure 2 — FOPS test configurations when attached to the vehicle chassis**

**5.1.3** A FOPS might be designed solely to protect the operator in the event of an object falling onto the tractor, but weather protection for the operator, of a more or less temporary nature, might also be fitted

on the structure. The operator will usually remove this in warm weather. In addition, there are FOPS whose cladding is permanent and for which warm-weather ventilation is provided by windows or flaps.

**5.1.3.1** Since the cladding can add strength to the FOPS and removable cladding could be absent when an incident occurs, all parts that are intended to be removable by the operator shall be removed for the purpose of the test. Doors, roof hatch, and windows that can be opened shall either be removed or fixed in the open position for the test, so that they do not add to the strength of the FOPS. It shall be noted whether, in this position, they would create a hazard for the operator in the event of an object falling. In the case of FOPS with a roof hatch that can be opened and is a member of the protective structure, the test shall be carried out in both the open and closed position.

**5.1.3.2** Throughout this International Standard, reference is made to the testing of the FOPS. This shall be understood to include cladding which cannot be removed during normal operation of the tractor. A description of any temporary cladding supplied shall be included in the specifications.

**5.1.3.3** All glass or similar brittle material shall be removed prior to testing. Tractor and ROPS components which might sustain needless damage during the test and which do not affect the strength of the FOPS or its dimensions may be removed prior to testing if the manufacturer so wishes.

**5.1.3.4** No repairs or adjustments shall be carried out during the test. Several identical samples can be provided by the manufacturer if several drop tests are required.

**5.1.4** Should the same structure be used for FOPS and ROPS evaluations, the FOPS test shall precede the ROPS test (according to ISO 3463, ISO 5700, ISO 12003-1, ISO 12003-2, or ISO 3471). The removal of impact dents or replacement of the FOPS cover is permitted.

## **5.2 Apparatus and procedure**

### **5.2.1 Apparatus**

**5.2.1.1** The drop object shall be a solid steel or ductile iron sphere as shown in [Figure 3](#), the impact surface of which shall have properties against deformation during testing. The drop object shall have a typical mass of 45 kg and a spherical contact surface diameter of between 200 mm and 250 mm.

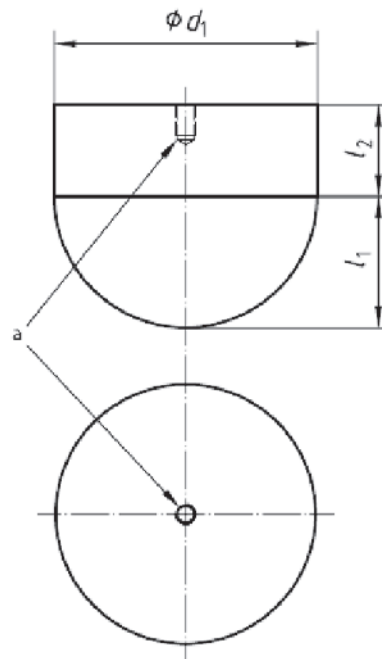

**Key**

- $d_1$  200 mm to 250 mm
- $l_1$  approximately 102 mm
- $l_2$  approximately 109 mm

a May be drilled and tapped for lifting eye.

NOTE Actual values of dimensions are given here as examples.

**Figure 3 — Example of test object**

**5.2.1.2** Means of raising the drop object to the required height.

**5.2.1.3** Means of releasing the drop object so that it drops without restraint.

**5.2.1.4** Surface of such firmness that it is not penetrated by the machine or test bed under the loading of the drop test.

**5.2.1.5** Means of determining whether the FOPS enters the safety zone during the drop test. This may be either of the following:

- a safety zone template, placed upright, made of material which will indicate any penetration by the FOPS, in which case grease or other suitable material may be applied on the lower surface of the FOPS cover to indicate such penetration;
- a dynamic instrumentation system of sufficient frequency response to indicate the expected deflection of the FOPS with respect to the safety zone.

The top area of the safety zone is defined by: the points, I1, A1, B1, C1, C2, B2, A2, I2, of the clearance zone for ISO 3463 and ISO 5700; the plane described in 10.2 d) and e) for ISO 12003-1:2008; the surface defined by points H1, A1, B1, C1, C2, B2, A2, H2 for ISO 12003-2, and the top of the DLV for ISO 3471.

In the event the tractor has a reversible driver's position (reversible seat and steering wheel), the safety zone shall be the combined envelope of the two DLVs defined by the two different positions of the steering wheel and the seat.

**5.2.1.6** The safety zone template, if any, shall be fixed to the same part of the tractor as the operator's seat and shall remain there during the entire formal test period.

## 5.2.2 Procedure

The drop test shall consist of the following operations in the order listed.

**5.2.2.1** Place the drop object (see [5.2.1.1](#)) on the top of the FOPS, at the location designated in [5.2.2.2](#).

**5.2.2.2** The drop location shall be located on the vertical projection of the top surface of the safety zone. When the safety zone is represented by the clearance zone, the point of impact shall be at a point which is furthest removed from major structural members (see [Figure 4](#)). When the safety zone is represented by the DLV, the impact location shall be entirely within the vertical projection of the safety zone, in that volume's upright position, on the top of the FOPS.

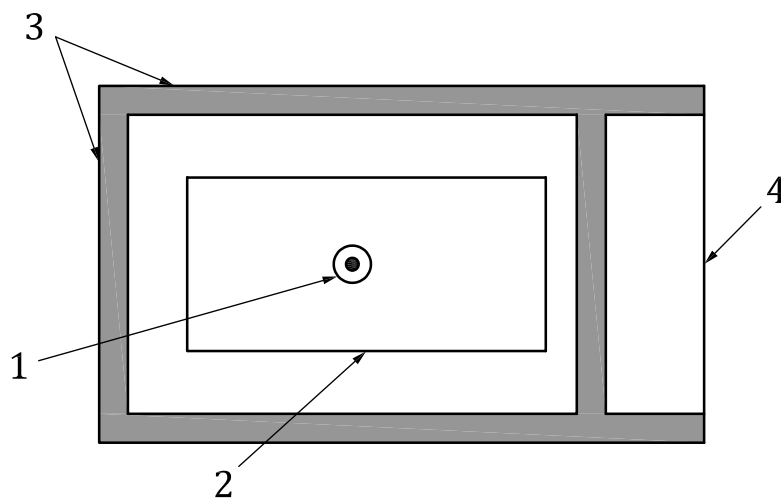

### Key

- 1 impact point
- 2 projection to the top of the clearance zone
- 3 major structural members
- 4 overhead cover

**Figure 4 — Impact point referred to the clearance zone**

Two cases shall be considered:

**5.2.2.2.1** Case 1: The major, upper, horizontal members of the FOPS do not enter the vertical projection of the safety zone on the top of the FOPS. The drop test object shall be placed as close as possible to the centre of gravity of the upper FOPS (see [Figure 5](#)).

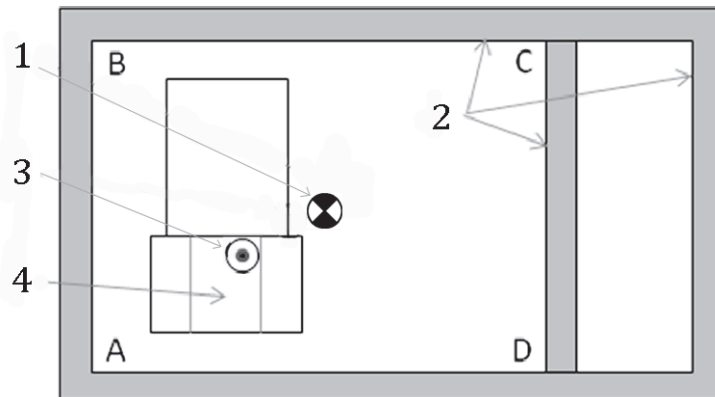

**Key**

- 1 centroid of A-B-C-D
- 2 major structural members
- 3 impact point
- 4 DLV top plane

**Figure 5 — Drop test impact points: Case 1**

**5.2.2.2.2 Case 2:** The major, upper, horizontal members of the FOPS do enter the vertical projection of the safety zone on the top of the FOPS. If the covering material of all the surface areas above the safety zone is of uniform thickness, the centre of the drop test object shall be in the surface of greatest area, this area being the vertical projected area of the safety zone without major, upper, horizontal members. The centre of the drop test object shall be at that point within the surface of greatest area which has the least possible distance from the centroid of the top of the FOPS (see [Figure 6](#)).

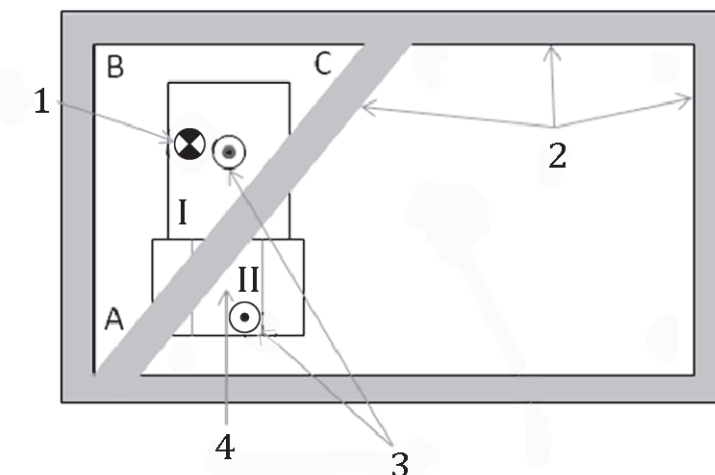

**Key**

- 1 centroid of A-B-C
- 2 major structural members
- 3 impact points
- 4 DLV top plane

NOTE Area I has a greater area than Area II.

**Figure 6 — Drop test impact points: Case 2**

**5.2.2.3** Irrespective of whether the safety zone is represented by the clearance zone or the DLV, if different materials or thicknesses of material are used in different areas above the safety zone, each area in turn shall be subjected to a drop test. If several drop tests are required, several identical samples of the FOPS (or parts of it) could be provided by the manufacturer (one for each drop test). If design features, such as openings for windows or equipment, or variations in covering material or thickness, indicate a more vulnerable location within the vertical projection of the safety zone, the drop location should be adjusted to that location. In addition, if openings in the FOPS cover are intended to be filled with devices or equipment to provide adequate protection, those devices or equipment shall be in place during the drop test.

**5.2.2.4** Raise the drop object vertically above the position indicated in [5.2.2.1](#) and [5.2.2.2](#) to a height sufficient to develop the energy of 1365 J.

**5.2.2.5** Release the drop object so that it falls without restraint onto the FOPS.

**5.2.2.6** As it is unlikely that the free fall will result in the drop test object hitting exactly at the location specified in [5.2.2.1](#) and [5.2.2.2](#), the following limits are placed on deviations.

**5.2.2.6.1** The impact of the drop object shall be entirely within a circle of 100 mm radius with a centre that shall coincide with the vertical centre line of the drop object as positioned according to [5.2.2.1](#) and [5.2.2.2](#).

**5.2.2.6.2** There is no limitation on location or attitude of subsequent impacts due to rebound.

## 6 Performance requirements

**6.1** The safety zone shall not be entered into by any part of the protective structure, or by the dropped object, under the first or subsequent impacts of the drop test object.

**6.2** After the drop test, the FOPS shall completely cover the vertical projection of the safety zone.

**6.3** The drop object shall not penetrate the FOPS.

## 7 Cold weather performance of protective structures

If the protective structure is claimed to have properties resistant to cold weather embrittlement, the manufacturer shall give the details that shall be included with the report. Cold weather embrittlement properties shall be verified either by performing the tests given in [Clause 5](#) at  $-18\text{ °C}$  or colder, or in accordance with [Annex A](#).

NOTE In some countries, FOPS are required to meet the cold weather embrittlement requirements of [Annex A](#), where a partial list of those countries is given.

## 8 Labelling

**8.1** Labelling is optional. When a label is provided, it shall contain at least the following information:

- a) name and address of the manufacturer of the protective structure;
- b) protective structure identification number (design or serial number);
- c) tractor make, model(s), or series number(s) that the protective structure is designed to fit;
- d) energy level met in test;
- e) reference to this International Standard.



**8.2** The label shall be durable and permanently attached to the protective structure such that it can be easily read and it shall be protected from environmental damage.

## **9 Test report**

**9.1** A test report shall be prepared. An acceptable test report format is provided in [Annex B](#). Should a different test format be used, it shall at a minimum contain the information required in [Annex B](#).

## Annex A (normative)

### Optional requirements for providing resistance to brittle fracture of falling-object protective structures (FOPS) at reduced operation temperature

The following requirements and procedure are intended to provide strength and resistance to brittle fracture at reduced temperature. The following minimum material requirements shall be met in judging the suitability of the FOPS at a reduced operating temperature in regions where this additional operating protection is required.

In certain countries, testing for cold weather embrittlement according to this annex is mandatory. See [Table A.1](#).

**Table A.1 — Countries for which proving cold weather embrittlement using the method described in this annex is mandatory**

Country	Country code
Canada	CA
United States	US

NOTE The requirements and procedure specified in A.2 and A.3 are provided until suitable International Standards are developed.

**A.1** Bolts and nuts used to attach the FOPS to the tractor and used to connect structural parts of the ROPS shall be in conformity with property class 8.8, 9.8, or 10.9 for bolts (see ISO 898-1) and property class 8, 9, or 10 for nuts (see ISO 898-2).

**A.2** Steel materials for structural members of the FOPS shall be of controlled toughness material exhibiting minimum Charpy V-notch impact energy requirements as shown in [Table A.2](#).

NOTE Steel with an as-rolled thickness less than 2,5 mm and with a carbon content less than 0,2 % is considered to meet this requirement.

Structural members of the FOPS made from materials other than steel shall have equivalent low temperature impact resistance. Specimens shall be “longitudinal” and taken from flat stock, tubular, or structural sections before forming or welding for use in the FOPS. Specimens from tubular or structural sections shall be taken from the middle of the biggest side and shall not include welds.

**A.2.1** The Charpy V-notch tests shall be made in accordance with the procedure in ASTM A370:1979, except that specimen sizes shall be in accordance with the dimensions given in [Table A.2](#).

**A.2.2** An alternative to this procedure is to use killed or semi-killed steel for which a specification shall be provided.

**A.3** All welding electrodes used in the fabrication of structural members and mounts shall be compatible with the FOPS structure material as given in A.2.

**Table A.2 — Minimum Charpy V-notch energy requirements for FOPS structure material at a specimen temperature of -20 °C and -30 °C**

Specimen size mm	Absorbed energy	
	-30 °C J	-20 °C J <sup>b</sup>
10 × 10 <sup>a</sup>	11	27,5
10 × 9	10	25
10 × 8	9,5	24
10 × 7,5 <sup>a</sup>	9,5	24
10 × 7	9	22,5
10 × 6,7	8,5	21
10 × 6	8	20
10 × 5 <sup>a</sup>	7,5	19
10 × 4	7	17,5
10 × 3,3	6	15
10 × 3	6	15
10 × 2,5 <sup>a</sup>	5,5	14

<sup>a</sup> Indicates preferred size. Specimen size shall be no less than the largest preferred size that the material will permit.

<sup>b</sup> The energy requirement at the temperature -20 °C is 2,5 times the value specified for -30 °C. Other factors affect impact energy strength, i.e. direction of rolling, yield strength, grain orientation, and welding. These factors shall be considered when selecting and using a steel.

## Annex B (normative)

### Test report for falling-object protective structures (FOPS)

#### B.1 General information

Use SI units in the test report, followed by other units (e.g. Imperial and U.S. customary), if necessary.

- Protective structure manufacturer's name and address:
- Submitted for test by:
- Make of protective structure:
- Model of the protective structure:
- Type of protective structure (cab, frame, rear roll bar, cab with integrated frame, etc.):
- Date, location of test, and standard version:

#### B.2 Specification of test tractor

##### B.2.1 Identification of tractor to which protective structure is fitted for the test

###### B.2.1.1 General

- Make of tractor:<sup>1)</sup>
- Model (trade name):
- Type of tractor [2-wheel drive or 4-wheel drive; rubber or steel tracks (if applicable); articulated 4-wheel drive or articulated 4-wheel drive with twin (dual) wheels (if applicable)]:

###### B.2.1.2 Numbers

- 1st serial no. or prototype no.:
- Serial no.:

###### B.2.1.3 Other specifications (if applicable)

- Model denomination(s) for other countries:
- Transmission type or gears x ranges:
  - Speed version:
  - Manufacturer identification or technical type number:

#### B.2.2 Tractor seat

- Tractor with a reversible driver's position (reversible seat and steering wheel): Yes/No

---

1) possibly different from tractor manufacturer's name

- Make/type/model of seat:
- Make/type/model of optional seat(s) and position(s) of the seat index point (SIP):
  - (description of seat 1 and SIP position)
  - (description of seat 2 and SIP position)
  - (description of seat \_ and SIP position)

### **B.3 Specification of protective structure**

#### **B.3.1** Photographs showing mounting details

**B.3.2** General arrangement drawing of the structure, including position of the seat index points (SIP) and details of mountings. The main dimensions must figure on the drawings, including external dimensions of tractor with protective structure fitted and main interior dimensions.

#### **B.3.3** Brief description of the protective structure comprising

- type of construction
- details of mountings

#### **B.3.4** Dimensions

When the tractor is fitted with different optional seats or has a reversible driver's position (reversible seat and steering wheel), the dimensions in relation to the seat index points shall be measured in each case (SIP 1, SIP 2, etc.).

- Height of roof members above the seat index point: mm
- Height of roof members above the tractor footplate: mm
- Overall height of the tractor with the protective structure fitted: mm
- Overall width of the protective structure (if mudguards are included, this is to be stated): mm

#### **B.3.5** Details of materials used in the construction of the protective structure and specifications of steels used

Steel specifications shall be in conformity with ISO 630-1:2011.

- Main frame: (parts – materials – sizes)
  - Is steel rimmed, semi-killed or killed:
  - Steel standard and reference:
- Mountings: (parts – materials – sizes)
  - Is steel rimmed, semi-killed or killed:
  - Steel standard and reference:
- Assembly and mounting bolts: (parts – sizes)
- Roof: (parts – materials – sizes)

**B.3.6** Details of tractor manufacturer's reinforcements on original parts

## **B.4 Test results**

### **B.4.1 Conditions of test**

#### **B.4.1.1** Falling object used:

- Sphere:
- Diameter: mm
- Mass: kg
- Height of drop: mm
- Number of drops:
- Energy level met in test: J

#### **B.4.1.2** Results:

##### **Statement:**

**The acceptance conditions of the test are fulfilled. The structure is a Falling-Object Protective Structure in accordance with this International Standard.**

**B.4.1.3** Documentation of impact location(s) showing the location relative to the safety zone and providing justification for their selection.

#### **B.4.1.4** Photographs:

One photograph of the test object and test arrangement before application of test. Additional photographs as necessary to show top and bottom of FOPS structure after the test.

### **B.4.2 Cold weather performance (resistance to brittle fracture)**

Method used to identify resistance to brittle fracture at reduced temperature:

Steel specifications shall be in conformity with ISO 630-1:2011.

Steel specification: (reference and relevant standard)

### **B.4.3 Tractor(s) to which the protective structure is fitted**

See [Table B.1](#).

**Table B.1 — Tractor(s) to which the protective structure is fitted**

Test reference number:										
Make	Model	Type	Other specifications	Mass			Tiltable	Wheel-base	Minimum Track	
		2/4-wheel drive, etc.	where applicable	Front	Rear	Total			Front	Rear
				kg	kg	kg	Yes/No	mm	mm	

## **Annex C** (informative)

### **Designation of Maintenance Agency**

A Maintenance Agency has been established by the ISO Technical Management Board (TMB) to ensure that technical harmonization can be maintained between ISO/TC 23/SC 2 Standards and OECD Tractor Test Codes. It operates through guidelines approved by the TMB, accessible at <http://standards.iso.org/iso/27850>, that entrust it to the following functions:

- a) to receive the requests for changes from recognized ISO/TC23/SC 2 P-members;
- b) to evaluate and resolve the requests for changes;
- c) to publish the approved changes.

Changes to this International Standard will be announced by the MA Secretariat to ISO/TC 23/SC 2 and will be made publicly available at <http://standards.iso.org/iso/27850>. They constitute authoritative amendments to [Clauses 1 to 9](#) and to the annexes of this International Standard.



## Bibliography

- [1] ISO 630-1:2011, *Structural steels — Part 1: General technical delivery conditions for hot-rolled products*
- [2] ISO 898-1, *Mechanical properties of fasteners made of carbon steel and alloy steel — Part 1: Bolts, screws and studs with specified property classes — Coarse thread and fine pitch thread*
- [3] ISO 898-2, *Mechanical properties of fasteners made of carbon steel and alloy steel — Part 2: Nuts with specified property classes — Coarse thread and fine pitch thread*
- [4] ISO 5353:1995, *Earth-moving machinery, and tractors and machinery for agriculture and forestry — Seat index point*
- [5] ISO 6814:2009, *Machinery for forestry — Mobile and self-propelled machinery — Terms, definitions and classification*
- [6] OECD Code 3:July 2012, *OECD Standard Code for the official testing of protective structures on agricultural and forestry tractors (dynamic test)*
- [7] OECD Code 4:July 2012, *OECD Standard Code for the official testing of protective structures on agricultural and forestry tractors (static test)*
- [8] OECD Code 6:July 2012, *OECD Standard Code for the official testing of front mounted roll-over protective structures on narrow-track wheeled agricultural and forestry tractors*
- [9] OECD Code 7:July 2012, *OECD Standard Code for the official testing of rear mounted roll-over protective structure on narrow-track wheeled agricultural and forestry tractors*
- [10] OECD Code 8:July 2012, *OECD Standard Code for the official testing of protective structures on agricultural and forestry track-laying tractors*
- [11] OECD Code 10:July 2012, *OECD Standard Code for the official testing of falling-object protective structures on agricultural and forestry tractors*





# British Standards Institution (BSI)

BSI is the national body responsible for preparing British Standards and other standards-related publications, information and services.

BSI is incorporated by Royal Charter. British Standards and other standardization products are published by BSI Standards Limited.

## About us

We bring together business, industry, government, consumers, innovators and others to shape their combined experience and expertise into standards-based solutions.

The knowledge embodied in our standards has been carefully assembled in a dependable format and refined through our open consultation process. Organizations of all sizes and across all sectors choose standards to help them achieve their goals.

## Information on standards

We can provide you with the knowledge that your organization needs to succeed. Find out more about British Standards by visiting our website at [bsigroup.com/standards](http://bsigroup.com/standards) or contacting our Customer Services team or Knowledge Centre.

## Buying standards

You can buy and download PDF versions of BSI publications, including British and adopted European and international standards, through our website at [bsigroup.com/shop](http://bsigroup.com/shop), where hard copies can also be purchased.

If you need international and foreign standards from other Standards Development Organizations, hard copies can be ordered from our Customer Services team.

## Subscriptions

Our range of subscription services are designed to make using standards easier for you. For further information on our subscription products go to [bsigroup.com/subscriptions](http://bsigroup.com/subscriptions).

With **British Standards Online (BSOL)** you'll have instant access to over 55,000 British and adopted European and international standards from your desktop. It's available 24/7 and is refreshed daily so you'll always be up to date.

You can keep in touch with standards developments and receive substantial discounts on the purchase price of standards, both in single copy and subscription format, by becoming a **BSI Subscribing Member**.

**PLUS** is an updating service exclusive to BSI Subscribing Members. You will automatically receive the latest hard copy of your standards when they're revised or replaced.

To find out more about becoming a BSI Subscribing Member and the benefits of membership, please visit [bsigroup.com/shop](http://bsigroup.com/shop).

With a **Multi-User Network Licence (MUNL)** you are able to host standards publications on your intranet. Licences can cover as few or as many users as you wish. With updates supplied as soon as they're available, you can be sure your documentation is current. For further information, email [bsmusales@bsigroup.com](mailto:bsmusales@bsigroup.com).

## BSI Group Headquarters

389 Chiswick High Road London W4 4AL UK

## Revisions

Our British Standards and other publications are updated by amendment or revision.

We continually improve the quality of our products and services to benefit your business. If you find an inaccuracy or ambiguity within a British Standard or other BSI publication please inform the Knowledge Centre.

## Copyright

All the data, software and documentation set out in all British Standards and other BSI publications are the property of and copyrighted by BSI, or some person or entity that owns copyright in the information used (such as the international standardization bodies) and has formally licensed such information to BSI for commercial publication and use. Except as permitted under the Copyright, Designs and Patents Act 1988 no extract may be reproduced, stored in a retrieval system or transmitted in any form or by any means – electronic, photocopying, recording or otherwise – without prior written permission from BSI. Details and advice can be obtained from the Copyright & Licensing Department.

## Useful Contacts:

### Customer Services

**Tel:** +44 845 086 9001

**Email (orders):** [orders@bsigroup.com](mailto:orders@bsigroup.com)

**Email (enquiries):** [cservices@bsigroup.com](mailto:cservices@bsigroup.com)

### Subscriptions

**Tel:** +44 845 086 9001

**Email:** [subscriptions@bsigroup.com](mailto:subscriptions@bsigroup.com)

### Knowledge Centre

**Tel:** +44 20 8996 7004

**Email:** [knowledgecentre@bsigroup.com](mailto:knowledgecentre@bsigroup.com)

### Copyright & Licensing

**Tel:** +44 20 8996 7070

**Email:** [copyright@bsigroup.com](mailto:copyright@bsigroup.com)



...making excellence a habit.™