



BSI Standards Publication

# Plastics — Preparation of test specimens of thermoplastic materials using mouldless technologies

Part 1: General principles, and laser sintering of test specimens

NO COPYING WITHOUT BSI PERMISSION EXCEPT AS PERMITTED BY COPYRIGHT LAW

*raising standards worldwide*<sup>™</sup>

Copyright British Standards Institution  
Provided by IHS under license with BSI - Uncontrolled Copy  
No reproduction or networking permitted without license from IHS

Not for Resale



**National foreword**

This British Standard is the UK implementation of ISO 27547-1:2010.

The UK participation in its preparation was entrusted to Technical Committee PRI/82, Thermoplastic materials.

A list of organizations represented on this committee can be obtained on request to its secretary.

This publication does not purport to include all the necessary provisions of a contract. Users are responsible for its correct application.

© BSI 2010

ISBN 978 0 580 58173 1

ICS 83.080.20

**Compliance with a British Standard cannot confer immunity from legal obligations.**

This British Standard was published under the authority of the Standards Policy and Strategy Committee on 30 November 2010.

**Amendments issued since publication**

Date	Text affected
------	---------------

---

---

---

**Plastics — Preparation of test specimens  
of thermoplastic materials using  
mouldless technologies —**

**Part 1:  
General principles, and laser sintering of  
test specimens**

*Plastiques — Préparation des éprouvettes de matériaux  
thermoplastiques par des techniques sans moule —*

*Partie 1: Principes généraux, et frittage laser des éprouvettes*



Reference number  
ISO 27547-1:2010(E)

© ISO 2010

**PDF disclaimer**

This PDF file may contain embedded typefaces. In accordance with Adobe's licensing policy, this file may be printed or viewed but shall not be edited unless the typefaces which are embedded are licensed to and installed on the computer performing the editing. In downloading this file, parties accept therein the responsibility of not infringing Adobe's licensing policy. The ISO Central Secretariat accepts no liability in this area.

Adobe is a trademark of Adobe Systems Incorporated.

Details of the software products used to create this PDF file can be found in the General Info relative to the file; the PDF-creation parameters were optimized for printing. Every care has been taken to ensure that the file is suitable for use by ISO member bodies. In the unlikely event that a problem relating to it is found, please inform the Central Secretariat at the address given below.



**COPYRIGHT PROTECTED DOCUMENT**

© ISO 2010

All rights reserved. Unless otherwise specified, no part of this publication may be reproduced or utilized in any form or by any means, electronic or mechanical, including photocopying and microfilm, without permission in writing from either ISO at the address below or ISO's member body in the country of the requester.

ISO copyright office  
Case postale 56 • CH-1211 Geneva 20  
Tel. + 41 22 749 01 11  
Fax + 41 22 749 09 47  
E-mail [copyright@iso.org](mailto:copyright@iso.org)  
Web [www.iso.org](http://www.iso.org)

Published in Switzerland

# Contents

Page

Foreword .....	iv
Introduction.....	v
1 Scope .....	1
2 Normative references .....	1
3 Terms and definitions .....	1
4 Apparatus .....	4
4.1 Test specimens.....	4
4.2 Laser-sintering machine .....	4
5 Procedure .....	4
5.1 Conditioning of the material.....	4
5.2 Laser sintering .....	4
5.3 Post-treatment of specimens .....	5
6 Report on test-specimen preparation .....	6
Annex A (informative) Laser-sintering parameters .....	7
Annex B (informative) Laser beam radius .....	9
Bibliography.....	11

## Foreword

ISO (the International Organization for Standardization) is a worldwide federation of national standards bodies (ISO member bodies). The work of preparing International Standards is normally carried out through ISO technical committees. Each member body interested in a subject for which a technical committee has been established has the right to be represented on that committee. International organizations, governmental and non-governmental, in liaison with ISO, also take part in the work. ISO collaborates closely with the International Electrotechnical Commission (IEC) on all matters of electrotechnical standardization.

International Standards are drafted in accordance with the rules given in the ISO/IEC Directives, Part 2.

The main task of technical committees is to prepare International Standards. Draft International Standards adopted by the technical committees are circulated to the member bodies for voting. Publication as an International Standard requires approval by at least 75 % of the member bodies casting a vote.

Attention is drawn to the possibility that some of the elements of this document may be the subject of patent rights. ISO shall not be held responsible for identifying any or all such patent rights.

ISO 27547-1 was prepared by Technical Committee ISO/TC 61, *Plastics*, Subcommittee SC 9, *Thermoplastic materials*.

ISO 27547 consists of the following part, under the general title *Plastics — Preparation of test specimens of thermoplastic materials using mouldless technologies*:

— *Part 1: General principles, and laser sintering of test specimens*

Further parts are planned covering other mouldless technologies.

## Introduction

Many factors in a mouldless specimen-preparation process can influence the properties of the test specimens prepared and hence the measured values obtained when the specimens are used in a test method. The mechanical properties of such specimens are in fact strongly dependent on the conditions of the process used to prepare the specimens. Exact definition of each of the main parameters of the process is a basic requirement for reproducible operating conditions.

It is important in defining specimen-preparation conditions to consider any influence the conditions could have on the properties to be determined. Specimens prepared by mouldless techniques could show differences in molecular morphology (as with crystalline and semicrystalline polymers), differences in powder morphology (after undergoing a sintering process, for instance), differences in thermal history and differences in thickness of the layers used to prepare the specimen. Each of these will have to be controlled to avoid differences in the values of the properties measured.

www.bsi.org.uk



# Plastics — Preparation of test specimens of thermoplastic materials using mouldless technologies —

## Part 1: General principles, and laser sintering of test specimens

### 1 Scope

This part of ISO 27547 specifies the general principles of test-specimen preparation using mouldless techniques. Sometimes, these techniques are called “tool-less” methods. Common to all these techniques is the fact that the specimens are produced layer by layer. The shape and dimensions of the specimens are defined in terms of a numerical description using CAD techniques. This computer model of the specimen is “sliced” into layers by means of suitable software. The specimen-preparation process then builds up the specimens automatically, layer by layer, using the computer model and a suitable computer-controlled laser-sintering machine. The three software systems used (for CAD, slicing the specimen into layers and machine control) may be independent systems interfacing separately with the machine or they may be integrated with the machine.

This part of ISO 27547 also specifies the general principles to be followed when test specimens of thermoplastic materials are prepared by laser sintering. The laser-sintering process is used to prepare specimens layer-wise by sintering the particles of a thermoplastic powder using the energy of a laser beam.

This part of ISO 27547 provides a basis for establishing reproducible sintering conditions. Its purpose is to promote uniformity in describing the main parameters of the sintering process and also to establish uniform practice in reporting sintering conditions.

The particular conditions required for reproducible preparation of test specimens which will give comparable results will vary for each material used. These conditions shall be as given in the International Standard for the relevant material or shall be agreed upon between the interested parties.

### 2 Normative references

The following referenced documents are indispensable for the application of this document. For dated references, only the edition cited applies. For undated references, the latest edition of the referenced document (including any amendments) applies.

ISO 291, *Plastics — Standard atmospheres for conditioning and testing*

### 3 Terms and definitions

For the purposes of this document, the following terms and definitions apply.

#### 3.1

##### **laser wavelength**

wavelength at the peak intensity of the laser used for sintering

NOTE It is expressed in nanometres.

### 3.2

#### **laser power**

power of the laser beam

NOTE 1 It is expressed in watts.

NOTE 2 The laser power is usually different when producing the contour (outline) of the specimen and when hatching the specimen. Both values are therefore reported.

### 3.3

#### **laser mode**

parameter indicating which of the various electromagnetic standing waves that can be produced in the laser cavity is actually being used in a particular application

### 3.4

#### **beam radius**

radius of the laser beam, determined in the way described in Annex B

NOTE It is expressed in millimetres.

### 3.5

#### **beam speed**

speed of travel of the laser beam across the surface of the specimen being prepared

NOTE 1 It is expressed in millimetres per second.

NOTE 2 The beam speed is usually different when producing the contour (outline) of the specimen and when hatching the specimen. Both values are therefore reported.

### 3.6

#### **powder-dispenser speed**

speed of the powder dispenser as it moves across the specimen-preparation chamber before preheating begins (see Figure A.1)

NOTE It is expressed in millimetres per minute.

### 3.7

#### **preheating temperature**

temperature to which the specimen-preparation chamber is heated before the specimen-preparation process starts

NOTE It is expressed in degrees Celsius.

### 3.8

#### **preheating time**

length of time the powder bed is heated before the specimen-preparation process starts

NOTE 1 It is expressed in minutes.

NOTE 2 The preheating time is rather long (approx. 30 min) as it is necessary to have a steady-state temperature which is the same throughout the whole specimen-preparation chamber.

### 3.9

#### **temperature of the powder**

temperature of the surface of the polymer powder

NOTE 1 It is expressed in degrees Celsius.

NOTE 2 Another important temperature is the controlled temperature of that part of the chamber near the sintered layer. It is also expressed in degrees Celsius.

### 3.10

#### **contour**

track followed by the laser beam when producing the outline of the specimen

NOTE For further details, see Annex A.

### 3.11

#### **hatching**

set of closely spaced parallel lines, within the contour line, along which the laser beam travels to produce the main body of the specimen

NOTE For further details, see Annex A.

### 3.12

#### **cool-down temperature**

temperature measured in the middle of the powder bed when the specimens are removed from the powder bed

NOTE It is expressed in degrees Celsius.

### 3.13

#### **inert gas**

inert gas which can be used to protect the polymer powder in the specimen-preparation chamber

### 3.14

#### **layer thickness**

thickness of the successive layers of powder used to prepare the specimen

NOTE 1 It is expressed in millimetres.

NOTE 2 The same layer thickness is used for every layer of a specimen.

### 3.15

#### **overall layer-preparation time**

overall time needed to prepare one layer

NOTE It is expressed in seconds.

### 3.16

#### **post-completion layers**

powder layers applied after completion of the sintering process

### 3.17

#### **specimen orientation**

orientation of the specimen in the powder bed

NOTE Designation of the specimen orientation is relative to the direction of the laser beam. Three different orientations are possible:

- a) flatwise;
- b) edgewise;
- c) upright.

### 3.18

#### **specimen position**

position of each specimen within the chamber, as defined by the following three parameters:

- a) the minimum distance allowed between any specimen and the chamber wall, expressed in mm;
- b) the minimum distance allowed between two adjacent specimens, expressed in mm;
- c) the number of specimens being produced in the run

## 4 Apparatus

### 4.1 Test specimens

This part of ISO 27547 describes the preparation of test specimens for the acquisition of data which are intended to be comparable (see ISO 10350-1, ISO 11403-1, ISO 11403-2 and ISO 11403-3) with data obtained from other laser-sintered specimens, as well as for use in the case of disputes. The dimensions of these specimens are given in ISO 3167 or ISO 20753.

Laser sintering is a method which can be used to prepare specimens of almost any shape. In order to generate comparable data, the conditions for the preparation of the test specimen described in Clause 5 apply. These conditions shall be reported as described in Clause 6.

### 4.2 Laser-sintering machine

The laser-sintering machine used for the preparation of specimens shall be capable of adjusting the laser power, the beam radius and beam speed and the layer thickness. It shall be possible to heat the specimen-preparation chamber, the powder and the inert gas (if used) in order to create reproducible conditions for the preparation of specimens of different polymers. It shall also be possible to measure the temperature within the powder bed.

The control system of the machine shall be capable of maintaining the operating conditions within the following tolerance limits:

— laser power, $P_L$	$\pm 10\%$
— beam radius, $R_B$	$\pm 5\%$
— contour offset	$\pm 10\ \mu\text{m}$
— distance between hatching lines	$\pm 10\ \mu\text{m}$
— beam speed, $V_B$	$\pm 10\ \text{mm/s}$
— temperature of the chamber, $T_C$	$\pm 3\ ^\circ\text{C}$
— temperature of the powder, $T_P$	$\pm 3\ ^\circ\text{C}$
— layer thickness	$\pm 10\ \mu\text{m}$

The size of the chamber shall allow all three types of specimen orientation mentioned in 3.17.

## 5 Procedure

### 5.1 Conditioning of the material

Prior to processing, condition the powder of the thermoplastic material as required by the relevant material standard, or as recommended by the manufacturer if no standard covers this subject.

To avoid condensation of moisture on to the material, avoid exposing it to the atmosphere while it is at a temperature significantly below the temperature of the workshop.

### 5.2 Laser sintering

**5.2.1** Feed into the numerical control the shapes and sizes of the specimens to be manufactured. In the case of laser sintering, it is permissible to prepare several specimens, as well as different specimen types, in one run. The number of specimens processed in one run shall not, however, exceed 15 — a maximum of five specimens at one level and a maximum of three levels. It is not permissible to prepare specimens together with other parts for other purposes.

**5.2.2** Set the machine to the conditions specified in the relevant material standard, or as agreed between the interested parties if no standard covers this subject.

Before starting the laser sintering, it is necessary to have a steady-state temperature within the whole chamber, and the preheating temperature shall be the same throughout the chamber.

Any of the three types of specimen orientation mentioned in 3.17 may be used but, in cases of dispute, the specimen orientation shall be "flatwise".

The powder-dispenser travel direction shall be parallel to the longitudinal axes of the specimens (see Figure A.1).

The sequence of operations shall be as follows:

- Following deposition of a particular layer,
  - either the contour shall first be produced for each of the specimens in turn and then the area within the contour hatched for each of the specimens,
  - or the contour shall be produced for the first specimen and this specimen then hatched, followed by the contour and hatching of the second specimen, and so on.
- This process shall be repeated for each subsequent layer.

The contour offset (see Figure A.2) shall not exceed 1,0 times the beam radius.

The distance between the hatching lines shall not exceed 1,0 times the beam radius.

The type of hatching shall be alternating (i.e. the laser beam shall travel along a hatching line in one direction and back along the next line in the opposite direction).

Since the laser power used to produce the contour of the specimen and for hatching the specimen will not usually be the same, both values shall be reported.

Since the beam speed used to produce the contour of the specimen and for hatching the specimen will not usually be the same, both values shall be reported.

**5.2.3** Record the specimen-preparation conditions.

**5.2.4** Carry out the specimen-preparation process in a single run. It is not permissible to stop the laser-sintering process and re-start it later. In the event of any interruption in the process, all the specimens in the chamber shall be rejected and not subsequently used for any purpose.

**5.2.5** After sintering all the specimens, apply the specified number of post-completion powder layers (see 3.16). Allow the specimens to cool down inside the powder bed until the cool-down temperature (see 3.12) is reached. This cool-down process may take place inside the sintering machine or outside, but it is recommended that this take place inside the machine. When the cool-down temperature has been reached, remove the specimens from the powder bed. The powder remaining in the chamber shall be discarded and not used for the preparation of any other specimens.

### **5.3 Post-treatment of specimens**

Once the specimens have been removed from the machine, clean adherent powder from them. If the specimens are made from thermoplastics which are sensitive to atmospheric exposure, protect them by keeping them in sealed, airtight containers at 23 °C, together with a desiccant if necessary. Store all other specimens at a standard atmosphere as defined in ISO 291 or as specified in the relevant material standard.

## 6 Report on test-specimen preparation

The report shall include the following information:

- a) a reference to this part of ISO 27547 (ISO 27547-1:2010);
- b) the date, time and place the specimens were produced;
- c) a full description of the material used (type, designation, manufacturer, lot number);
- d) details of any conditioning of the material carried out prior to processing;
- e) the type of specimen produced and the relevant standard;
- f) details of the laser-sintering machine used (manufacturer, type, etc.);
- g) the conditions:
  - 1) the laser wavelength, in nanometres,
  - 2) the laser mode,
  - 3) the laser power used when producing the contour, in watts,
  - 4) the laser power used when hatching, in watts,
  - 5) the beam radius, in millimetres,
  - 6) the contour offset, in millimetres,
  - 7) the type of hatching, if not alternating,
  - 8) the distance between the hatching lines, in millimetres,
  - 9) the sequence of operations used to prepare the specimens,
  - 10) the beam travel speed when producing the contour, in millimetres per minute,
  - 11) the beam travel speed when hatching, in millimetres per minute,
  - 12) the powder-dispenser speed, in millimetres per minute,
  - 13) the preheating temperature, in degrees Celsius,
  - 14) the preheating time, in minutes,
  - 15) the overall temperature in the specimen-preparation chamber, in degrees Celsius,
  - 16) the cool-down temperature, in degrees Celsius,
  - 17) the type of inert gas, if used,
  - 18) the layer thickness, in micrometres,
  - 19) the overall layer-preparation time, in seconds,
  - 20) the specimen orientation,
  - 21) the specimen positions,
  - 22) the number of post-completion layers;
- h) any other relevant details (e.g. the number of specimens prepared, the number of specimens retained, any post-sintering treatment).

## Annex A (informative)

### Laser-sintering parameters

The purpose of this annex is to explain, with the aid of figures, some of the parameters which are important in the laser sintering of test specimens.

Figure A.1 shows a view of the interior of the specimen-preparation chamber in a laser-sintering machine during preparation of the second layer of a set of multipurpose test specimens as specified in ISO 3167 or ISO 20753. The specimen orientation is “flatwise” relative to the laser beam direction.

The powder dispenser is shown in three different positions (numbered 1 to 3) as it moves across the specimen-preparation chamber from left to right while depositing powder onto the powder bed in the chamber. The time needed to move across the whole chamber defines the powder-dispenser speed. The direction of travel of the powder dispenser is parallel to the longitudinal axes of the specimens.

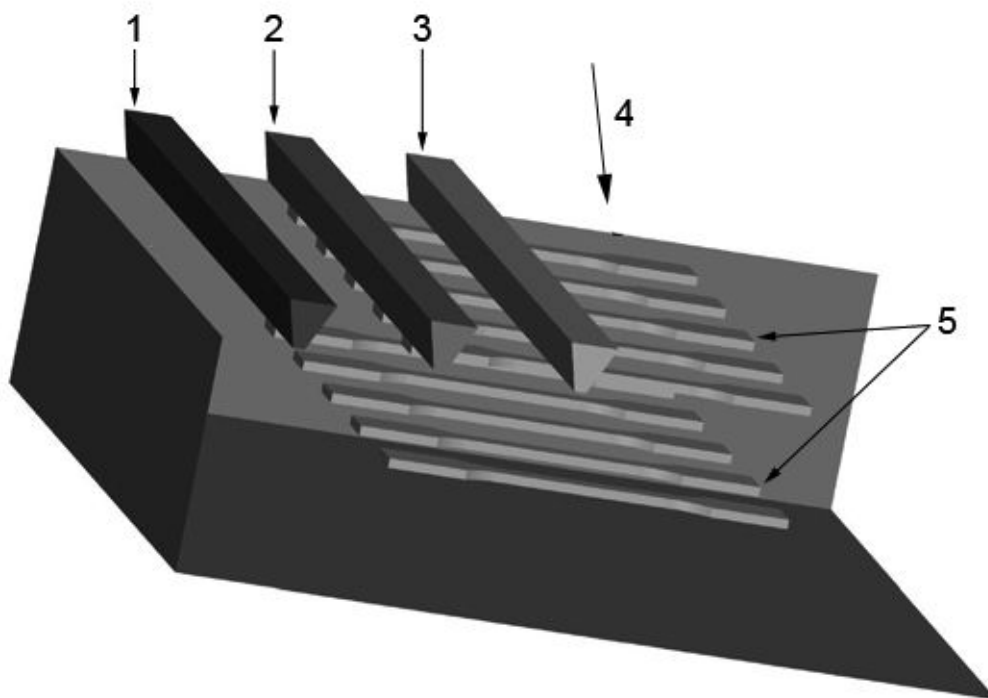

#### Key

- 1, 2, 3 successive positions of powder dispenser
- 4 laser beam entering specimen-preparation chamber from above
- 5 test specimens

**Figure A.1 — View of the interior of the specimen-preparation chamber in a laser-sintering machine**

Figure A.2 shows, using the multipurpose test specimen as an example, two important laser-sintering parameters: the contour offset and the distance between the hatching lines.

For each layer sintered to build up the specimen, the laser beam first follows the track represented by the contour line and then hatches the area inside the contour line.

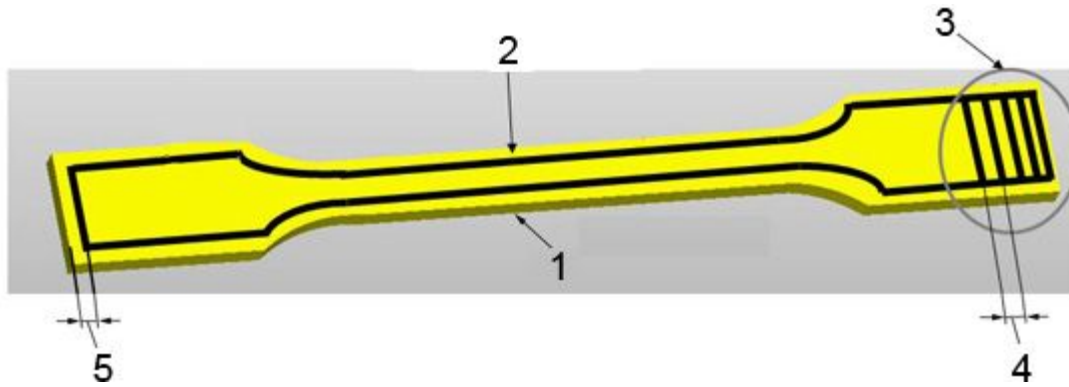

**Key**

- 1 specimen
- 2 contour (track followed by laser beam when producing the outline of the specimen)
- 3 hatching
- 4 distance between hatching lines
- 5 contour offset

**Figure A.2 — Contour and hatching parameters explained for a multipurpose test specimen**

.....



## Annex B (informative)

### Laser beam radius

The radius of the laser beam is important in defining a number of the parameters which need to be confirmed when laser-sintering specimens. It is therefore essential to know the radius of the beam.

A practical, relatively inexpensive approach to the determination of the beam radius is illustrated in Figure B.1.

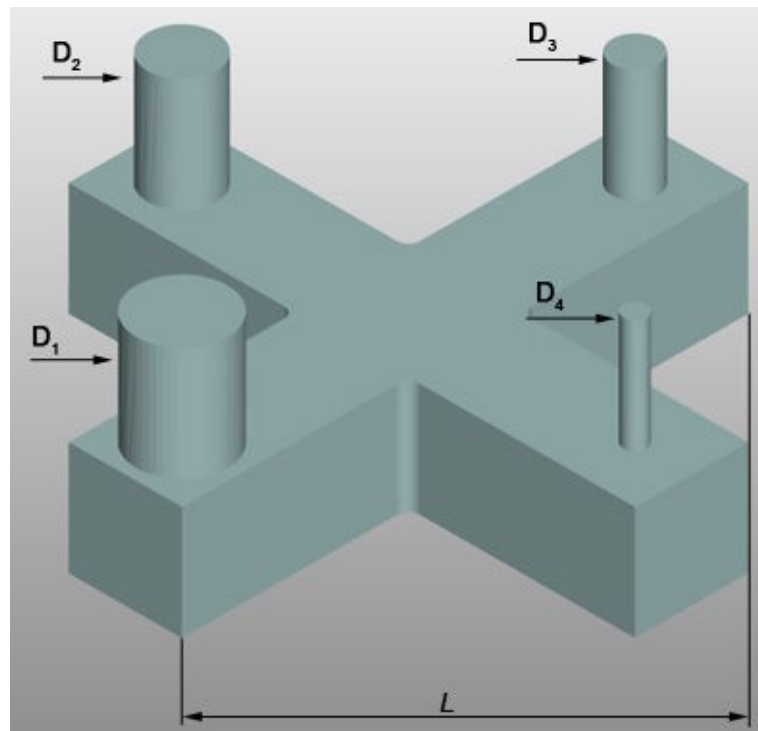
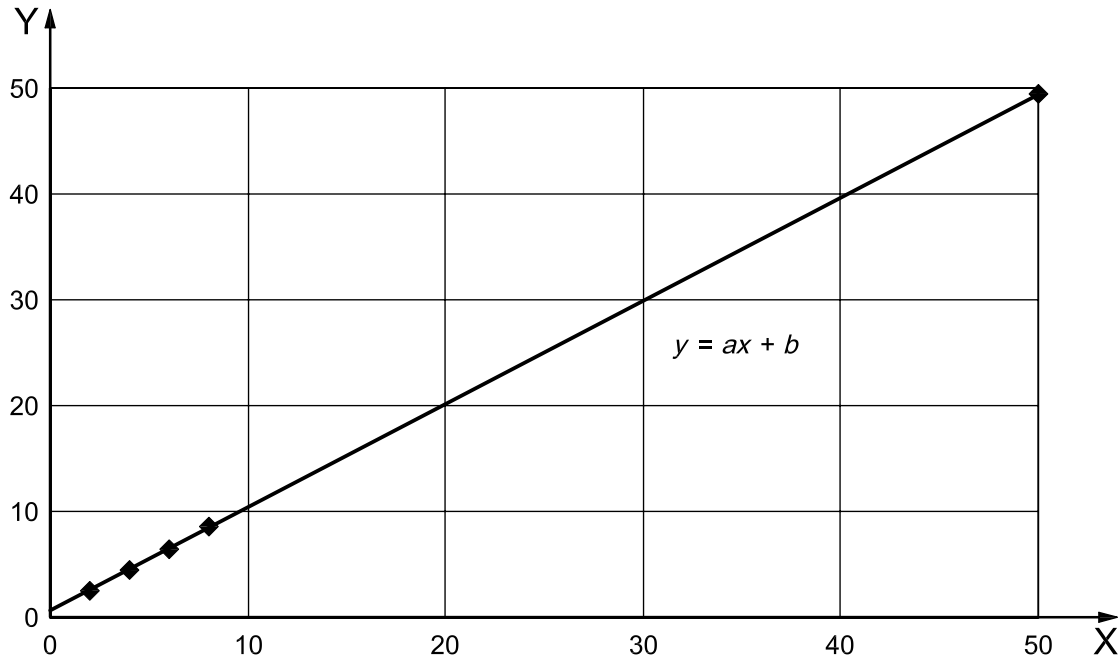

Figure B.1 — Geometry used for measurement of laser beam radius (“compensation cross”)

The computer model of the specimen (see Clause 1) defines the values of the length  $L$  and the diameters of the four cylinders ( $D_1$  to  $D_4$ ). After preparing the “compensation cross” by laser sintering, the actual values for  $L$ ,  $D_1$ ,  $D_2$ ,  $D_3$  and  $D_4$  are measured. Plotting the measured values against the defined values gives a graph as shown in Figure B.2.



**Key**

- X values as defined in computer programme (mm)
- Y measured values (mm)

**Figure B.2 — Graph used to determine the laser beam radius**

By drawing the best-fit straight line through the plotted points, a linear equation  $y = ax + b$  is obtained, where  $b$  is the radius of the laser beam.

NOTE The slope  $a$  of the line is related to the shrinkage, defined as  $(1 - a)$ .

## Bibliography

- [1] ISO 3167, *Plastics — Multipurpose test specimens*
- [2] ISO 10350-1, *Plastics — Acquisition and presentation of comparable single-point data — Part 1: Moulding materials*
- [3] ISO 11403-1, *Plastics — Acquisition and presentation of comparable multipoint data — Part 1: Mechanical properties*
- [4] ISO 11403-2, *Plastics — Acquisition and presentation of comparable multipoint data — Part 2: Thermal and processing properties*
- [5] ISO 11403-3, *Plastics — Acquisition and presentation of comparable multipoint data — Part 3: Environmental influences on properties*
- [6] ISO 20753, *Plastics — Test specimens*

---

---

**ICS 83.080.20**

Price based on 11 pages

© 2014 British Standards Institution

# British Standards Institution (BSI)

BSI is the independent national body responsible for preparing British Standards and other standards-related publications, information and services.

It presents the UK view on standards in Europe and at the international level.

It is incorporated by Royal Charter.

## Revisions

British Standards are updated by amendment or revision. Users of British Standards should make sure that they possess the latest amendments or editions.

It is the constant aim of BSI to improve the quality of our products and services. We would be grateful if anyone finding an inaccuracy or ambiguity while using this British Standard would inform the Secretary of the technical committee responsible, the identity of which can be found on the inside front cover.

**Tel: +44 (0)20 8996 9001 Fax: +44 (0)20 8996 7001**

BSI offers Members an individual updating service called PLUS which ensures that subscribers automatically receive the latest editions of standards.

**Tel: +44 (0)20 8996 7669 Fax: +44 (0)20 8996 7001**

**Email: [plus@bsigroup.com](mailto:plus@bsigroup.com)**

## Buying standards

You may buy PDF and hard copy versions of standards directly using a credit card from the BSI Shop on the website [www.bsigroup.com/shop](http://www.bsigroup.com/shop). In addition all orders for BSI, international and foreign standards publications can be addressed to BSI Customer Services.

**Tel: +44 (0)20 8996 9001 Fax: +44 (0)20 8996 7001**

**Email: [orders@bsigroup.com](mailto:orders@bsigroup.com)**

In response to orders for international standards, it is BSI policy to supply the BSI implementation of those that have been published as British Standards, unless otherwise requested.

## Information on standards

BSI provides a wide range of information on national, European and international standards through its Knowledge Centre.

**Tel: +44 (0)20 8996 7004 Fax: +44 (0)20 8996 7005**

**Email: [knowledgecentre@bsigroup.com](mailto:knowledgecentre@bsigroup.com)**

Various BSI electronic information services are also available which give details on all its products and services.

**Tel: +44 (0)20 8996 7111 Fax: +44 (0)20 8996 7048**

**Email: [info@bsigroup.com](mailto:info@bsigroup.com)**

BSI Subscribing Members are kept up to date with standards developments and receive substantial discounts on the purchase price of standards. For details of these and other benefits contact Membership Administration.

**Tel: +44 (0)20 8996 7002 Fax: +44 (0)20 8996 7001**

**Email: [membership@bsigroup.com](mailto:membership@bsigroup.com)**

Information regarding online access to British Standards via British Standards Online can be found at [www.bsigroup.com/BSOL](http://www.bsigroup.com/BSOL)

Further information about BSI is available on the BSI website at [www.bsigroup.com/standards](http://www.bsigroup.com/standards)

## Copyright

Copyright subsists in all BSI publications. BSI also holds the copyright, in the UK, of the publications of the international standardization bodies. Except as permitted under the Copyright, Designs and Patents Act 1988 no extract may be reproduced, stored in a retrieval system or transmitted in any form or by any means – electronic, photocopying, recording or otherwise – without prior written permission from BSI. This does not preclude the free use, in the course of implementing the standard of necessary details such as symbols, and size, type or grade designations. If these details are to be used for any other purpose than implementation then the prior written permission of BSI must be obtained. Details and advice can be obtained from the Copyright & Licensing Manager.

**Tel: +44 (0)20 8996 7070**

**Email: [copyright@bsigroup.com](mailto:copyright@bsigroup.com)**

## BSI Group Headquarters

389 Chiswick High Road London W4 4AL UK

Tel +44 (0)20 8996 9001

Fax +44 (0)20 8996 7001

[www.bsigroup.com/standards](http://www.bsigroup.com/standards)

*raising standards worldwide™*

Copyright British Standards Institution  
Provided by IHS under license with BSI - Uncontrolled Copy  
No reproduction or networking permitted without license from IHS

Not for Resale

