

BS ISO 27027:2014



BSI Standards Publication

Aerospace — Solid-state remote power controllers — General performance requirements

bsi.

...making excellence a habit.™

National foreword

This British Standard is the UK implementation of ISO 27027:2014. It supersedes BS ISO 27027:2008 which is withdrawn.

The UK participation in its preparation was entrusted to Technical Committee ACE/6, Aerospace avionic electrical and fibre optic technology.

A list of organizations represented on this committee can be obtained on request to its secretary.

This publication does not purport to include all the necessary provisions of a contract. Users are responsible for its correct application.

© The British Standards Institution 2014.
Published by BSI Standards Limited 2014

ISBN 978 0 580 79259 5

ICS 49.060

Compliance with a British Standard cannot confer immunity from legal obligations.

This British Standard was published under the authority of the Standards Policy and Strategy Committee on 31 October 2014.

Amendments/corrigenda issued since publication

Date	Text affected
------	---------------

INTERNATIONAL
STANDARD

ISO
27027

Second edition
2014-10-15

**Aerospace — Solid-state remote
power controllers — General
performance requirements**

*Aéronautique et espace — Contacteurs-disjoncteurs statiques
commandés à distance — Exigences générales de performance*



Reference number
ISO 27027:2014(E)

© ISO 2014



COPYRIGHT PROTECTED DOCUMENT

© ISO 2014

All rights reserved. Unless otherwise specified, no part of this publication may be reproduced or utilized otherwise in any form or by any means, electronic or mechanical, including photocopying, or posting on the internet or an intranet, without prior written permission. Permission can be requested from either ISO at the address below or ISO's member body in the country of the requester.

ISO copyright office
Case postale 56 • CH-1211 Geneva 20
Tel. + 41 22 749 01 11
Fax + 41 22 749 09 47
E-mail copyright@iso.org
Web www.iso.org

Published in Switzerland

Contents

Page

Foreword	iv
Introduction	v
1 Scope	1
2 Normative references	1
3 Terms and definitions	1
4 Requirements	4
4.1 Detail requirements.....	4
4.2 Electrical characteristics.....	4
4.3 Performance.....	4
5 Quality assurance provisions	6
5.1 Electrical characteristics.....	6

Foreword

ISO (the International Organization for Standardization) is a worldwide federation of national standards bodies (ISO member bodies). The work of preparing International Standards is normally carried out through ISO technical committees. Each member body interested in a subject for which a technical committee has been established has the right to be represented on that committee. International organizations, governmental and non-governmental, in liaison with ISO, also take part in the work. ISO collaborates closely with the International Electrotechnical Commission (IEC) on all matters of electrotechnical standardization.

The procedures used to develop this document and those intended for its further maintenance are described in the ISO/IEC Directives, Part 1. In particular the different approval criteria needed for the different types of ISO documents should be noted. This document was drafted in accordance with the editorial rules of the ISO/IEC Directives, Part 2 (see www.iso.org/directives).

Attention is drawn to the possibility that some of the elements of this document may be the subject of patent rights. ISO shall not be held responsible for identifying any or all such patent rights. Details of any patent rights identified during the development of the document will be in the Introduction and/or on the ISO list of patent declarations received (see www.iso.org/patents).

Any trade name used in this document is information given for the convenience of users and does not constitute an endorsement.

For an explanation on the meaning of ISO specific terms and expressions related to conformity assessment, as well as information about ISO's adherence to the WTO principles in the Technical Barriers to Trade (TBT) see the following URL: [Foreword - Supplementary information](#)

The committee responsible for this document is ISO/TC 20, *Aircraft and space vehicles*, Subcommittee SC 1, *Aerospace electrical requirements*.

This second edition cancels and replaces the first edition (ISO 27027:2008), which has been technically revised.

Introduction

This International Standard is the general performance requirements of the solid state (remote) power controller (SSPC) for aerospace.

Trend of aircrafts electric power system will be toward high voltage system. To accompany that trend, arc fault in the aircraft's wiring will become one of the major problems for the electric power distribution system. This second edition takes into account the arc fault detection.

The purpose of this International Standard, the definitions of SSPC and the contents of the document are as follows:

- a) The purpose of this International Standard
 - 1) To standardize the requirements for SSPC those are physically and environmentally diversified.
 - 2) To provide the applicable standard document for various SSPC.
- b) The definitions of SSPC
 - 1) Consists of a solid-state switching device and its driver circuit.
 - 2) Turns on/off the power output by receiving the control signal.
 - 3) Detects the over current in the load which results in limiting this current or shutting down for this current and/or optionally detects the arc fault in the circuit which results in shutting down the fault.
 - 4) Indicates the on/off status of the power output.
- c) The contents of this International Standard
 - 1) Definitions of the technical term.
 - 2) Electrical requirements.
 - 3) Test methods.

In order to satisfy the purpose of this International Standard, requirements such as physical, environmental, and individual items are specified in accordance with the detail requirements that are issued individually.

Aerospace — Solid-state remote power controllers — General performance requirements

1 Scope

This International Standard specifies the definitions, titles of general performance requirements, and test methods to determine the performance of solid state (remote) power controller (SSPC) for use in aerospace electrical power systems.

The SSPC consists of solid state-switching device(s) and associated solid-state circuitry for protection, action of control signals, and providing status information.

2 Normative references

The following documents, in whole or in part, are normatively referenced in this document and are indispensable for its application. For dated references, only the edition cited applies. For undated references, the latest edition of the referenced document (including any amendments) applies.

ISO 1540, *Aerospace — Characteristics of aircraft electrical systems*

ISO 7137, *Aircraft — Environmental conditions and test procedures for airborne equipment*

3 Terms and definitions

For the purposes of this document, the following terms and definitions apply.

3.1

arc fault

sustained luminous discharge of electricity across a gap in a circuit or between conductors

Note 1 to entry: Arc impedance can reduce low-voltage fault current magnitudes appreciably.

3.2

current limiting

function to limit the power output current to the required level within required time from overload or short circuit conditions which is shown in [Figure 2](#)

3.3

load voltage

voltage between the power output terminal of the SSPC and the power ground

3.4

load voltage rise and fall time (D.C. devices and non-zero crossing turn-off A.C. devices)

time interval between 10 % and 90 % of the steady state load voltage value which is shown in [Figure 1 a\)](#) for D.C. devices

3.5

off state

condition which, with the turn-off signal applied, the device prevents power from being passed to the load

3.6

on state

condition which, with the turn-on signal applied, the device allows power to be passed to the load

3.7
parallel arc fault
arc fault condition in which arcing occurs in a circuit from line-to-line or line-to-ground and not through any load(s)

Note 1 to entry: Only the arc impedance and the system current impedance limit the magnitude of the arc fault current.

3.8
peak let-through current
peak value of the current at maximum system voltage that the SSPC will conduct for a specified time interval without damage

3.9
power dissipation
power dissipation which includes all power dissipated in the power switching circuit, power losses due to internal leakage currents, and power supplies

Note 1 to entry: When SSPC is OFF, the power dissipation includes only dissipation due to leakage currents and internal power supplies.

3.10
reset
restoration of the tripped SSPC to a state from which it can be turned ON

3.11
reverse current
current into the load terminal of the SSPC from the load energy source

3.12
series arc fault
arc fault condition in which the current passes through the arc and each circuit load

Note 1 to entry: The load equipment limits the magnitude of the arc fault current.

3.13
short circuit
circuit with the impedance of less than 1 mΩ applied between the output terminal and ground

3.14
soft on/off
function for the power output current to increase linearly with turn-on signal and to decrease linearly with turn-off signal

3.15
supply voltage
voltage applied between the power input terminal of the SSPC and the power ground

3.16
trip
automatic reversion to the OFF state of the SSPC output caused by an overload condition or detection of arc fault

3.17
trip curve
curve which sets the minimum and maximum trip points of the SSPC and is plotted as current verses time

3.18
trip free
feature which will prevent subsequent re-closing unless preceded by a reset signal, when the SSPC has tripped due to an overcurrent condition or detection of arc fault

3.19

trip time

time interval between the application of an overcurrent condition or detection of arc fault and the 10 % value of rated output current

Note 1 to entry: In general, the higher the overcurrent condition, the shorter is the trip time.

3.20

turn-off signal

control signal level at which the power controller is turned OFF

3.21

turn-on signal

control signal level at which the power controller is turned ON

3.22

turn-off time

A.C. devices with zero-crossing turn-off

time interval between initiation of turn-off signal and the time when the output switch is OFF at zero crossing

Note 1 to entry: Shown in [Figure 1 b](#)).

3.23

turn-off time

D.C. devices and non-zero crossing turn-off A.C. devices

time interval between initiation of turn-off signal and the time when the output reach 10 % of its steady-state ON value

Note 1 to entry: Shown in [Figure 1 a](#)).

3.24

turn-on time

A.C. devices with zero-crossing turn-on

time interval between initiation of turn-on signal and the time when the output switch is ON at zero crossing

Note 1 to entry: Shown in [Figure 1 b](#)).

3.25

turn-on time

D.C. devices and non-zero crossing turn-on A.C. devices

time interval between initiation of turn-on signal and the time when the output reach 90 % of its steady-state ON value

Note 1 to entry: Shown in [Figure 1 a](#)).

3.26

unwanted trip

tripping function in response to a condition that is not an arcing fault but a condition that occurs as part of the normal or anticipated operation of circuit components

Note 1 to entry: Nuisance trip is synonymous with unwanted trip.

3.27

voltage drop

voltage across load and line terminals of the SSPC in the ON state at the specified load

3.28

zero voltage turn-on/zero current turn-off (A.C. devices only)

characteristic that requires the SSPC to turn ON and turn OFF only at the half-cycle zero-crossing point, regardless of when the control signal is applied or removed

4 Requirements

4.1 Detail requirements

The individual item requirements shall be specified in accordance with the detail requirements that are issued individually. It is recommended to use ISO 7137 for the specification of environmental conditions and test procedures for the SSPCs installed in the airborne equipment.

4.2 Electrical characteristics

When tested as specified in [5.1](#), the SSPC shall operate with supply voltage variations in accordance with ISO 1540 or the detail requirements, and the SSPC shall be capable of controlling all type of loads as required by the detail requirements.

4.3 Performance

4.3.1 Control signals

When tested as specified in [5.1.2](#), the control signals shall be as specified in the detail requirements.

4.3.2 Turn-on and turn-off time

When tested as specified in [5.1.3](#), the turn-on and turn-off time shall be as specified in the detail requirements.

4.3.3 Load voltage rise and fall time (soft on/off function)

When tested as specified in [5.1.4](#), the rise and fall time as the soft on/off function shall be as specified in the detail requirements.

4.3.4 Isolation

The control/power isolation test voltage shall be as specified in the detail requirements, when tested as specified in [5.1.5](#).

4.3.5 Control signal levels

When tested as specified in [5.1.6](#), the control signal levels shall be as specified (see [4.1](#)). Where maximum control signals are specified (see [4.1](#)) the signal shall be applied for 10 min without any damage to the SSPC.

4.3.6 Voltage drop

When tested as specified in [5.1.7](#), the voltage drop shall not exceed the values specified in the detail requirements for load current values from no load to 100 % rated.

4.3.7 Off-state leakage current

When tested as specified in [5.1.8](#), the leakage current shall not exceed the values specified in the detail requirements.

4.3.8 Off-state output voltage

When tested as specified in [5.1.9](#), the output voltage shall not exceed the values specified in the detail requirements.

4.3.9 Power dissipation

When tested as specified in [5.1.10](#), the power dissipation shall not exceed the values specified in the detail requirements.

4.3.10 Overload characteristics

4.3.10.1 Current limiting

When specified in the detail requirements and tested as specified in [5.1.11.1](#), the output current shall be within the trip curve specified. At the initiation of the overload condition, the peak let through current (see [4.1](#)) shall not exceed the value specified.

4.3.10.2 Trip characteristics with the overload condition

When tested as specified in [5.1.11.2](#), the SSPC shall not reset until commanded, the trip time shall be within the trip curve specified in the detail requirements without any damage.

4.3.11 State indication

The SSPC shall provide the means of state indication specified in the detail requirements when tested as specified in [5.1.12](#). State indication shall include the detection of load current above or below a minimum current threshold and the presence or absence of drive to the output power switches as specified in the detail requirements. These state indication means, in conjunction with the control signal, shall be capable of providing feedback on normal controller operation or controller faults as specified in the detail requirements.

4.3.12 Trip-free characteristics

When tested as specified in [5.1.13](#), the SSPC shall reset, trip-out, and stay tripped out for the duration of the test.

4.3.13 Zero voltage turn-on and zero current turn-off ([Figure 1 b](#))

When tested as specified in [5.1.14](#), the SSPC turn-on shall occur at zero voltage crossover within the voltage or time specified, and the SSPC turn-off shall occur at zero current crossover within the current or time specified. The SSPC shall turn-on and turn-off at the same voltage slope when specified.

4.3.14 Reverse current

When specified in the detail requirements and tested as specified in [5.1.15](#), the SSPC shall not be damaged and shall be performed as specified.

4.3.15 Exponential rate of voltage rise

When tested as specified in [5.1.16](#), the SSPC shall achieve the specified output voltage within the specified time.

4.3.16 Arc fault characteristics

4.3.16.1 Trip characteristics with parallel arc fault

When tested as specified in [5.1.17.1](#) and [5.1.17.2](#), the SSPC shall trip by parallel arc fault, the trip time shall be within the trip curve specified in the detail requirements without any damage.

4.3.16.2 Trip characteristics with series arc fault

When tested as specified in [5.1.17.3](#), the SSPC shall trip by series arc fault, the trip time shall be within the trip characteristics specified in the detail requirements without any damage.

4.3.16.3 Compatibility with normal load

When tested as specified in [5.1.17.4](#), the SSPC shall not trip by normal loads.

4.3.16.4 Compatibility with arc fault of another line

When tested as specified in [5.1.17.5](#), the SSPC shall not trip by the arc fault on another circuit on the same source.

5 Quality assurance provisions

5.1 Electrical characteristics

5.1.1 General

When performing electrical tests, the SSPC shall be mounted on a suitable heat sink (see [4.1](#)). Unless otherwise specified, all tests shall be made within the following ambient condition¹⁾.

- a) Temperature: +15 °C to +35 °C.
- b) Relative Humidity: Not greater than 85 %.
- c) Ambient Pressure: 84 kPa to 107 kPa, which correspond to the altitude between +1 525 m and -460 m (+5 000 feet and -1 500 feet).

5.1.2 Control signals (see [4.3.1](#))

5.1.2.1 General

The control signals shall be verified as specified in [5.1.2.2](#) and [5.1.2.3](#).

5.1.2.2 Turn-on signal

With the SSPC connected as shown in [Figure 3](#), apply rated supply voltage and adjust the load resistance for rated load ± 5 %. Apply the minimum turn-on signal with the control function generator and note that the SSPC turns ON.

5.1.2.3 Turn-off signal

With the SSPC ON at rated control signal, apply the maximum turn-off signal with the function generator and note that the SSPC turns OFF.

5.1.3 Turn-on and turn-off time

Measure turn-on and turn-off time with the SSPC operated as in [5.1.2.2](#) and [5.1.2.3](#).

5.1.4 Load voltage rise and fall time

Measure the rise and fall time with the SSPC operated as in [5.1.2.2](#) and [5.1.2.3](#).

1) The condition is in coordination with DO-160F published by RTCA, Inc.

5.1.5 Isolation (see [4.3.4](#))

The power-in terminal, power-out terminal, and power-ground terminal shall be shorted together. All remaining terminals shall be shorted together. The points of application shall be the signal ground and power ground terminals and electrification time shall be two minutes, maximum, as specified in the detail requirements. Unless otherwise specified, use the test procedure in ISO 7137, 3.9.

5.1.6 Control signal levels (see [4.3.5](#))

With rated supply voltage applied, apply control signals with the level as specified (see [4.1](#)) and measure control current or voltage. Repeat test for each control signal level specified (see [4.1](#)).

5.1.7 Voltage drop (see [4.3.6](#))

With the SSPC connected as shown in [Figure 3](#), measure the voltage between the power-in and the power-out terminals while operating at 10 %, 50 %, and 100 % rated load. For [Figure 1 b](#)), a true RMS voltmeter shall be used.

5.1.8 Leakage current (see [4.3.7](#))

Connect the SSPC as shown in [Figure 3](#) with the load resistance adjusted for maximum of 10 Ω , rated supply voltage applied to the power in terminal with the control circuit commanded OFF, read the leakage current.

5.1.9 Off-state output voltage (see [4.3.8](#))

Connect the SSPC as shown in [Figure 3](#), without the load resistance, rated supply voltage applied to the power IN terminal with the control circuit commanded OFF, read the output voltage on a voltmeter of internal resistance 10 M Ω minimum.

5.1.10 Power dissipation (see [4.3.9](#))

Connect the SSPC as shown in [Figure 3](#) with the load resistance adjusted for short circuit, rated supply voltage applied to the power in terminal, and the controller commanded OFF. Calculate the power dissipation for the OFF state, including bias and control. With the controller commanded ON, calculate the power dissipation for the ON state for loads of 10 %, 50 %, and 100 % rated load, unless otherwise specified in the specification sheet, including bias and control power.

5.1.11 Overload characteristic tests

5.1.11.1 Current limiting (see [4.3.10.1](#))

Connect the SSPC as shown in [Figure 3](#). With the load adjusted to the rated level, apply rated supply voltage and turn on the control. While monitoring the current out of the SSPC, apply a short circuit across the load and measure the peak let-through current and the current limit level.

5.1.11.2 Trip characteristics (see [4.3.10.2](#))

Connect the SSPC as shown in [Figure 3](#). With rated supply voltage, verify that the SSPC meets the trip characteristics at various current levels as specified in the detail requirements.

5.1.12 State indication signal(s) (see [4.3.11](#))

Connect the SSPC as shown in [Figure 3](#). Apply rated voltage and adjust the load resistance for 100 % rated load. Apply an OFF command to the control input. Monitor the specified (see [4.1](#)) state indication feedback to verify normal OFF operation and delay time. Apply an ON command to the control input and verify normal ON operation and delay time. Reduce the load current below the indication. Increase the

load current above the trip threshold and observe that the SSPC trips and verify specified (see 4.1) trip indication and delay times.

5.1.13 Trip-free characteristics (see 4.3.12)

With the SSPC connected as shown in Figure 3, apply rated voltage adjust load resistor for short circuit and command controller ON. Observe the SSPC trips out. Reset the controller and command controller ON. Maintain the ON command for one minute minimum and verify that the SSPC resets and trips only once.

5.1.14 Zero voltage turn-on (ZVTO) and zero current turn-off (ZCTO) (see 4.3.13)

Connect the SSPC as shown in Figure 3. Apply rated supply voltage and adjust load impedance for rated load with a 45 % lagging power factor. Apply the nominal turn-on signal and subsequently apply the nominal turn-off signal. Monitor the load voltage and current. Repeat test 10 times. Adjust the load impedance to reduce the load current below the specified (see 4.1) minimum and repeat.

5.1.15 Reverse current (see 4.3.14)

Connect the SSPC as shown in Figure 4 with load capacitance according to the detail requirements. Charge the rated supply voltage to the load capacitor. While monitoring the current the power-in line of the SSPC, close S_1 and record the current waveforms. The SSPC shall perform as specified after dissipating a reverse energy.

5.1.16 Exponential rate of voltage rise (see 4.3.15)

The SSPC shall be tested for exponential rate of voltage rise (when applicable) using the following procedure.

- a) See Figure 5 for the test setup.
- b) Apply the specified control turn-off voltage.
- c) Adjust voltmeter V_1 to the maximum rated voltage. For Figure 1 b), V_1 is the maximum rated voltage:

$$V_1 = \sqrt{2} \times V_{\text{rated,RMS}}$$

- d) With the power terminals (in and out) of the device disconnected, adjust resistor R_1 to a value determined by

$$R_1 = 0,632 \times \frac{V_1}{C_1 (dV/dt)}$$

where

dV/dt is as specified in Figure 5.

- e) Reconnect the power terminals (in and out) of the device under test to the circuit shown in Figure 5.
- f) Close and open switch S_1 for a minimum of 10 times. After five cycles, reverse the leads to the device under test (for A.C. devices only).
- g) Verify with oscilloscope CH1 (or equivalent instrument) that the device achieves the specified output voltage within the specified time.

5.1.17 Arc fault characteristics

5.1.17.1 Guillotine test (see 4.3.16.1)

With the SSPC connected as shown in Figure 6, apply rated supply voltage and turn on the control. Apply the short-circuit with guillotine. Verify that the SSPC meets the trip characteristics as specified in the

detail requirements without any damage and verify the current of guillotine and that the SSPC does not become trip state for the over current.

5.1.17.2 Wet arc fault test (see [4.3.16.1](#))

Prepare an electrolyte solution made by dissolving $3\% \pm 0.5\%$ by weight of sodium chloride in distilled water. Support the pre-damaged wires in free air. Position the delivery system so that the electrolyte contacts the wires from a height of 14 cm to 16,5 cm at a point which shall position the droplets into gap point. The gap is specified in the detail requirements

With the SSPC connected as shown in [Figure 7](#), apply rated supply voltage and turn on the control. Apply the short-circuit with a continual salt-water drop into the gap between the insulation breaches of damaged wires. Verify that the SSPC meets the trip characteristics as specified in the detail requirements without any damage.

5.1.17.3 Intermittent connection test (see [4.3.16.2](#))

With the SSPC connected as shown in [Figure 8](#), apply rated supply voltage and turn on the control. Apply the loose connection with gap and vibration specified in the detail requirements. Verify that the SSPC meets the trip characteristics as specified in the detail requirements without any damage. To minimize further damage to the test fixture, test shall not exceed 1 min. Example of load is resistive load, inductive load, motor load, capacitive load, light, switching power supply, and so on. Load current shall be 80 % rated current.

5.1.17.4 Compatibility with normal load (see [4.3.16.3](#))

With the SSPC connected as shown in [Figure 9](#), apply rated supply voltage and turn on the control. Apply the normal load until it reaches a steady-state condition. Example of load is resistive load, inductive load, motor load, capacitive load, light, switching power supply, and so on. The SSPC shall not become trip state. Repeat test five times.

5.1.17.5 Compatibility with arc fault of another line (see [4.3.16.4](#))

With the SSPC connected as shown in [Figure 10](#), apply rated supply voltage and turn on the control. Apply the short-circuit with guillotine for approximately 1 s. The SSPC shall not become trip state. Repeat test three times. Power supply shall be capable of sourcing the current.

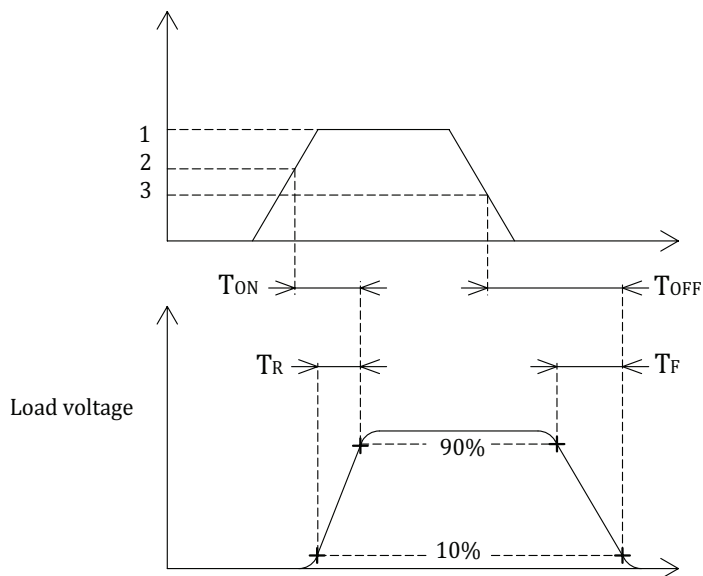

a) D.C. SSPC

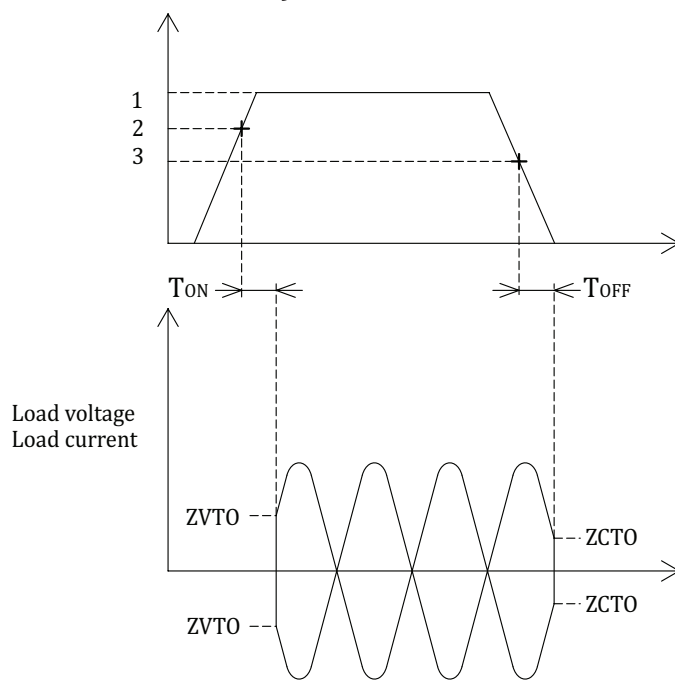

b) A.C. SSPC

Key

- 1 rated control signal
- 2 turn on (min)
- 3 turn off (max)
- T_{ON} turn-on time
- T_{OFF} Turn-off time

- T_R rise time
- T_F fall time
- ZVTO zero voltage turn-on
- ZCVO zero current turn-off

Figure 1 — Illustration of timing characteristics

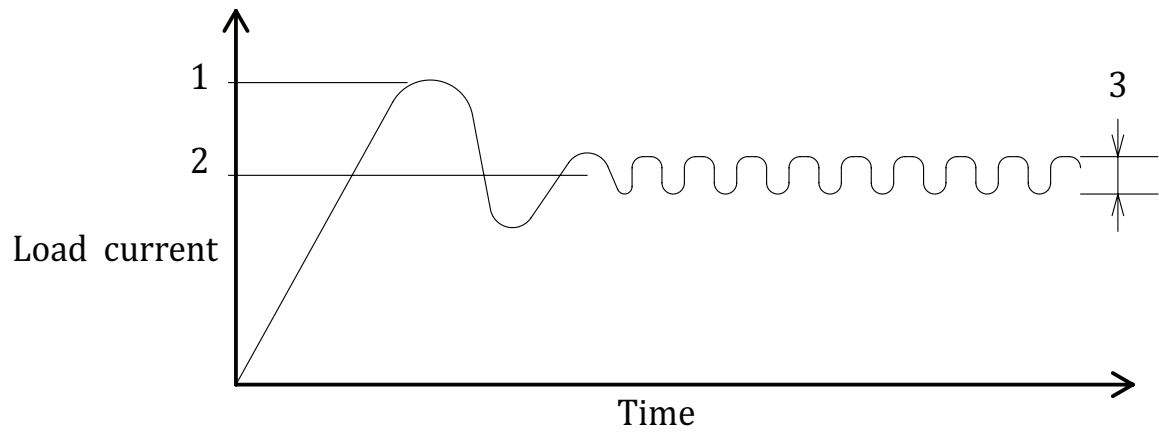

Key

- 1 peak let through current
- 2 specified current limit
- 3 ripple

Figure 2 — Overload let through current

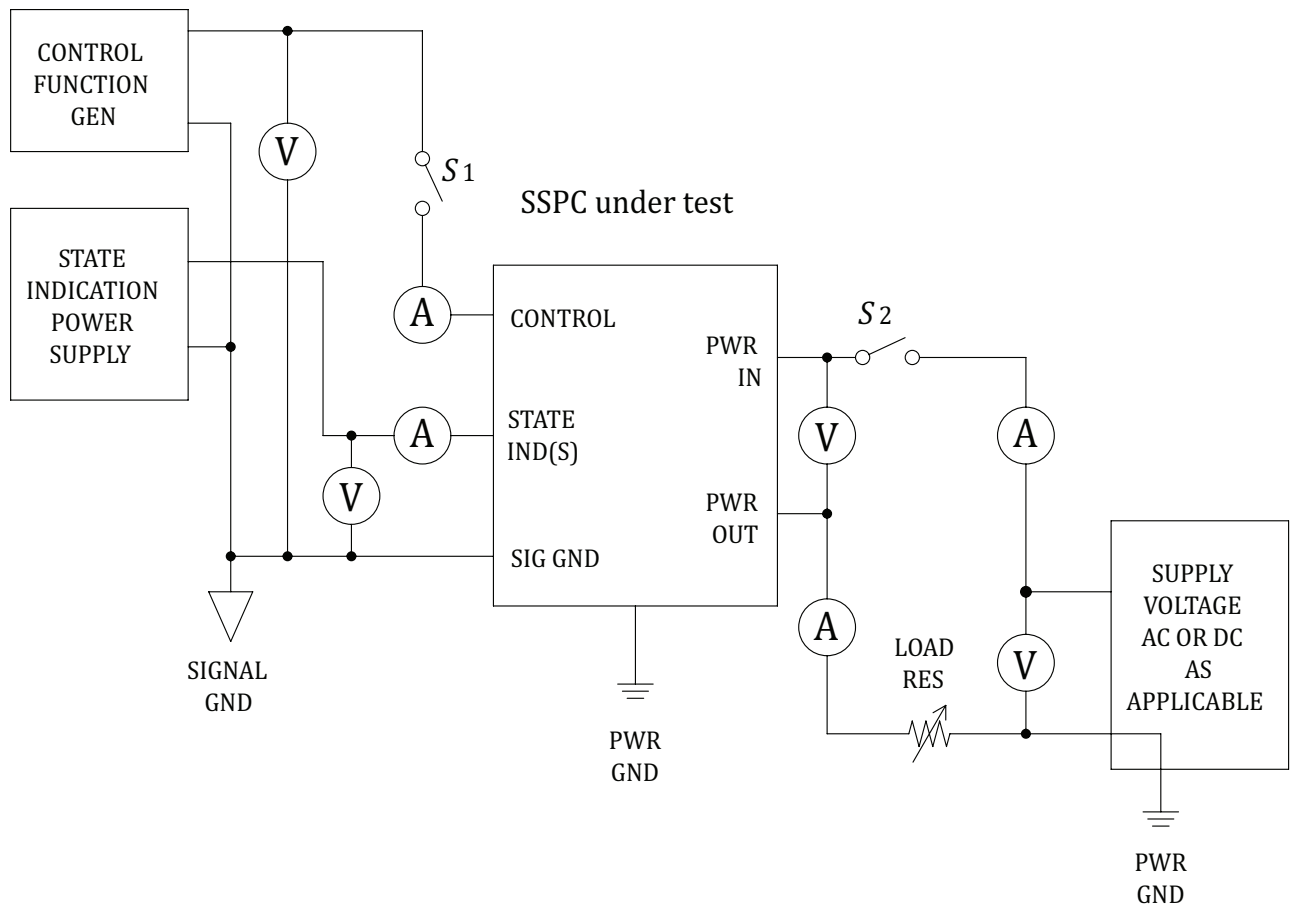

Key
 S₁ bounceless switch

Figure 3 — Test circuit

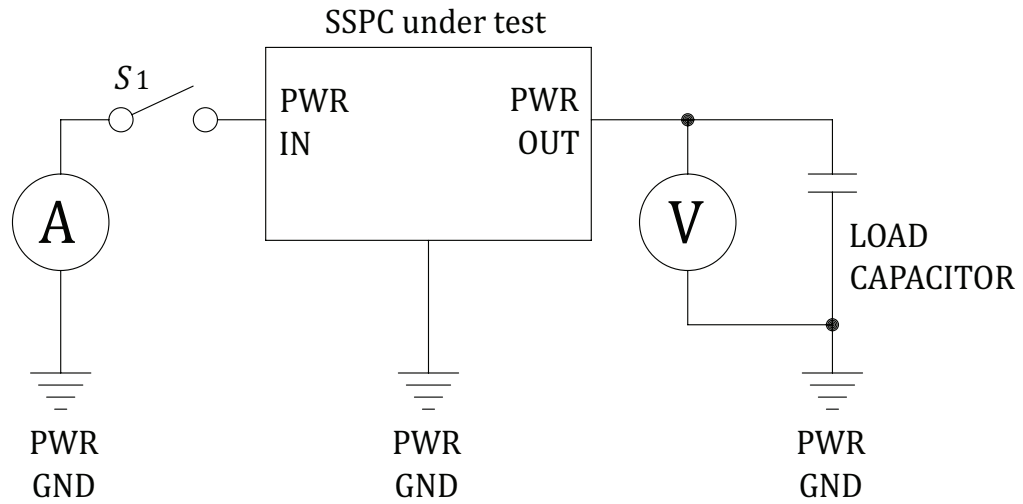

Key

S_1 bounceless switch

Figure 4 — Test circuit for reverse current

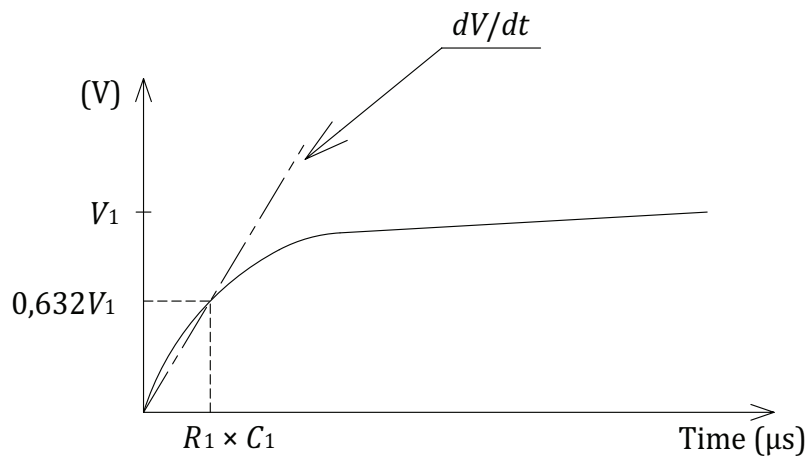
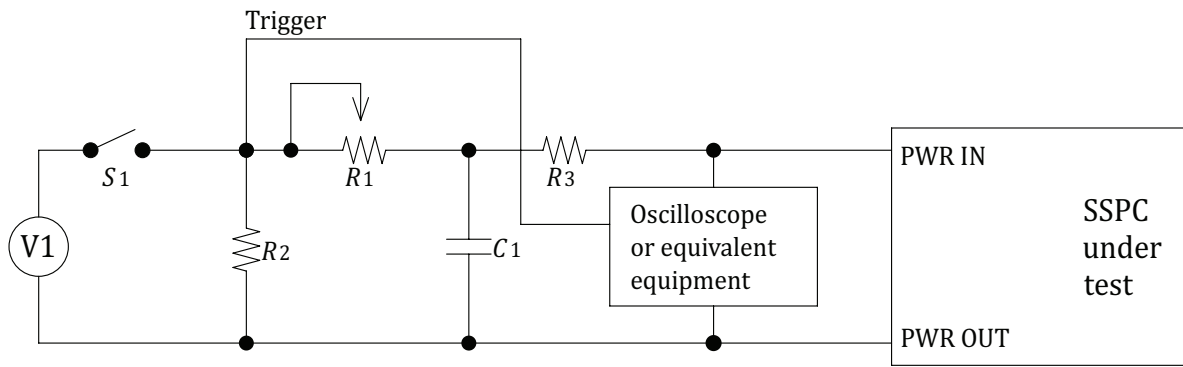

Key

V_1 maximum rated output voltage (A.C. devices use $V_1 = \sqrt{2} \times V_{\text{rated,RMS}}$)

$$R_1 = 0,632 \times \frac{V_1}{C_1 (dV/dt)}$$

R_2 1,0 M Ω (5 %), 1/2 W

R_3 50 Ω (5 %)

C_1 0,01 μF (5 %)

S_1 10A bounceless switch

Figure 5 — Test circuit for exponential rise in voltage

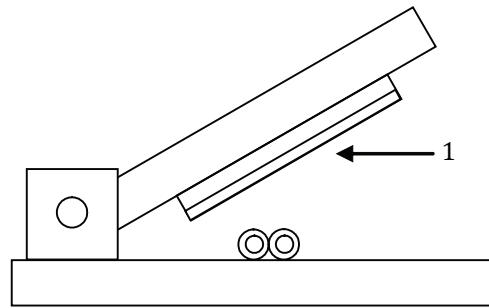

a) Guillotine appearance example

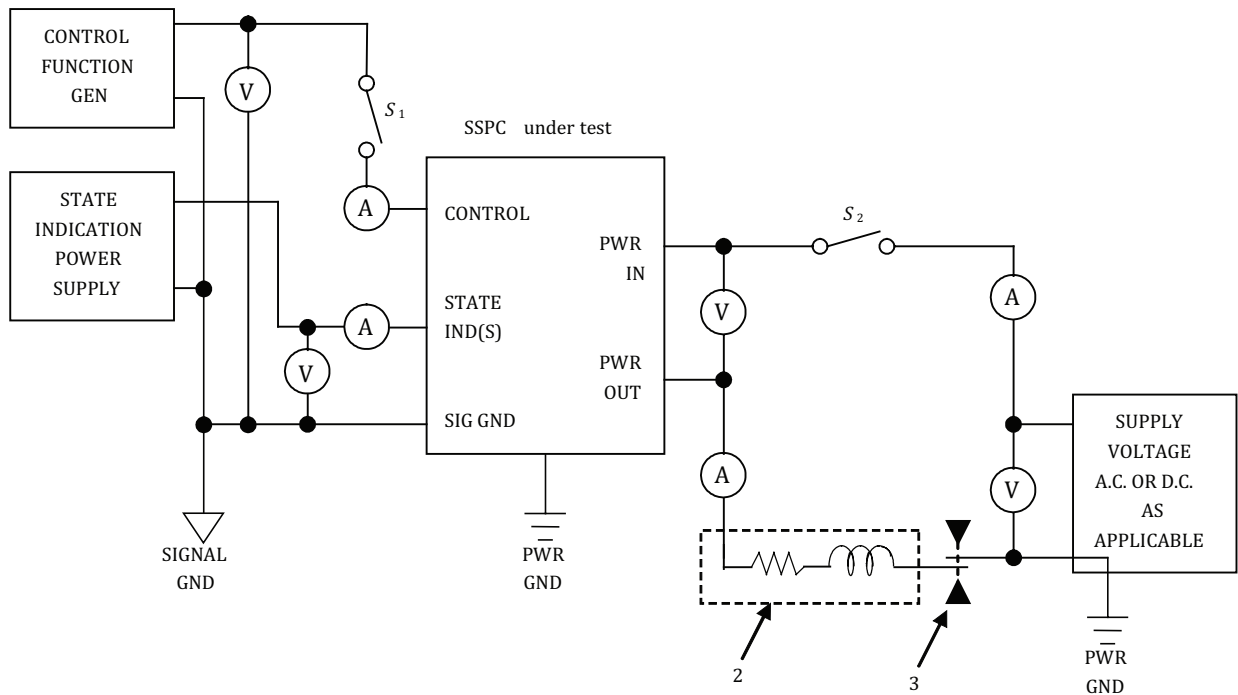

b) Test circuit

Key

- 1 sharp razor blade with one conductor
- 2 current limiting wires
- 3 guillotine

Figure 6 — Test setup for Guillotine test

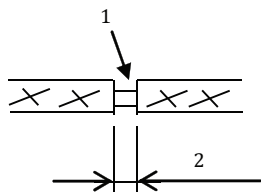

Pre-damaged wires detail

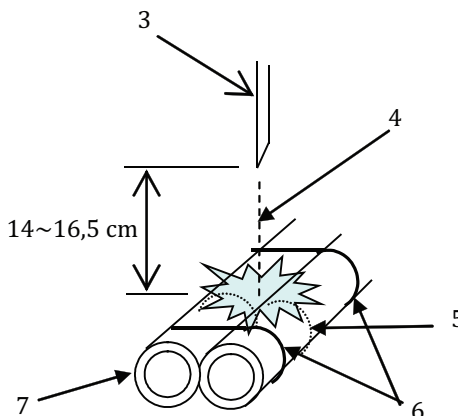

a) Water drops appearance example

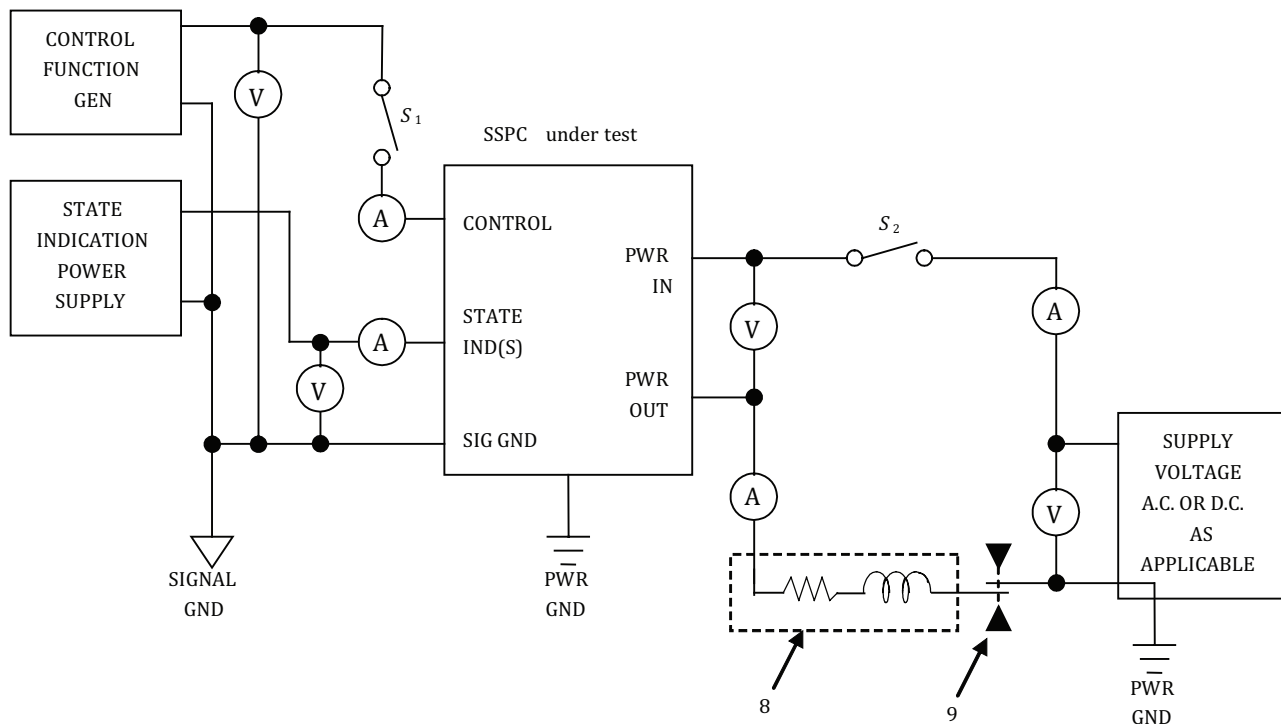

b) Test circuit

Key

- 1 pre-damaged point
- 2 gap
- 3 drop needle
- 4 water drops (8 ~ 10 drops per minute of 3 % ± 0.5 % sodium chloride solution)

- 5 gap between the insulation breaches (ref. pre-damaged wires detail)
- 6 tie wrap
- 7 pre-damaged wires(20 cm ~ 40 cm)
- 8 current limiting wires
- 9 water drops

Figure 7 — Test setup for wet arc track test

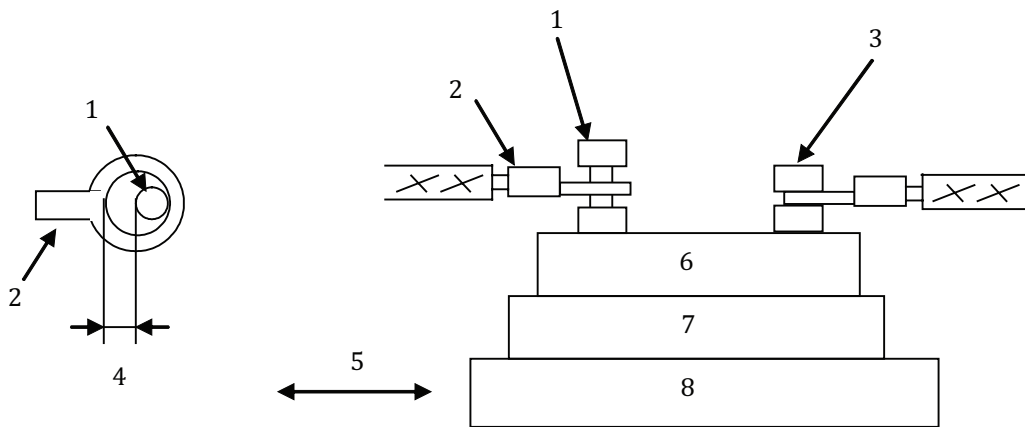

a) Intermittent connection appearance example

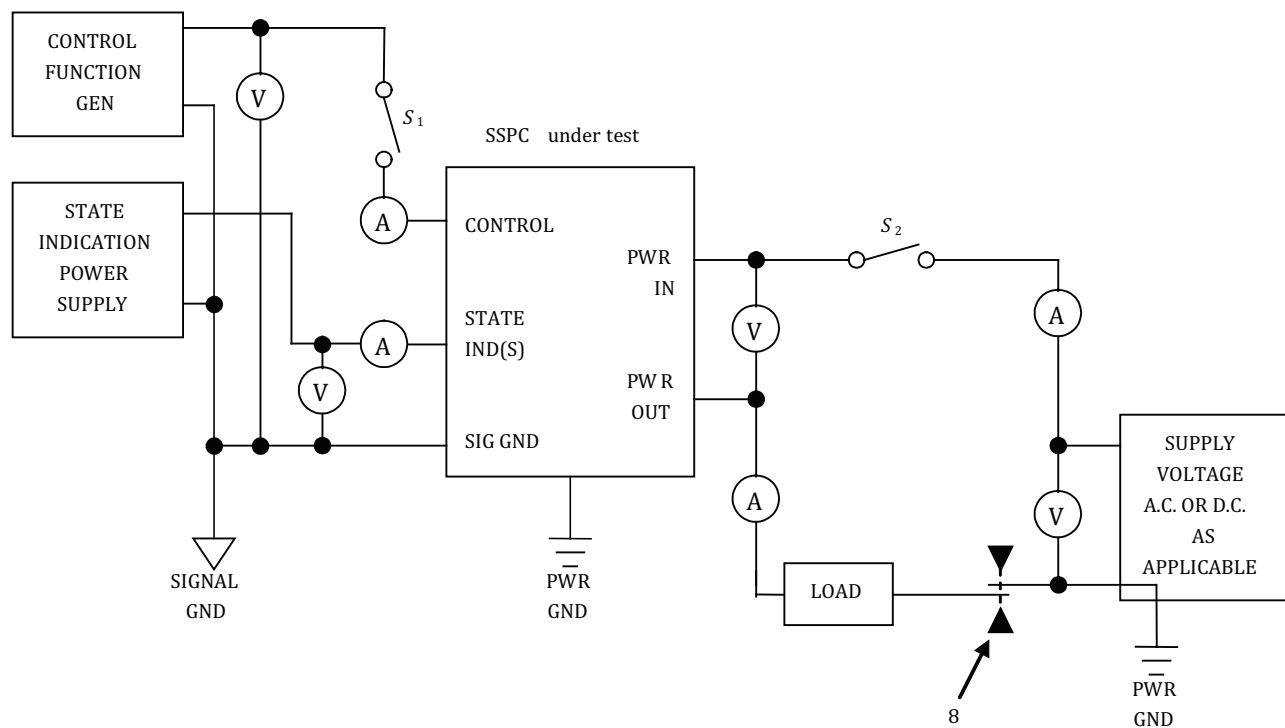

b) Test circuit

Key

- 1 loose terminal
- 2 lug
- 3 tight terminal
- 4 gap
- 5 vibration
- 6 conductive plate
- 7 insulation plate
- 8 vibration plate

Figure 8 — Test setup for intermittent connection test

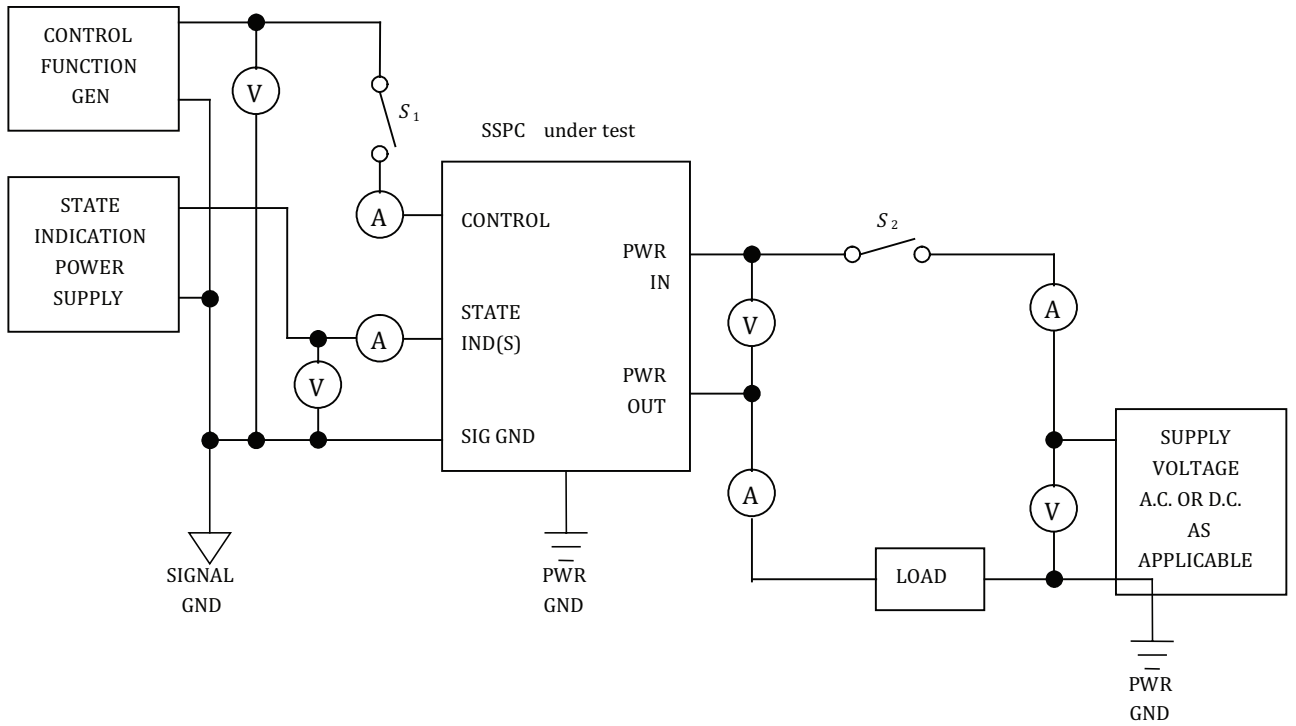
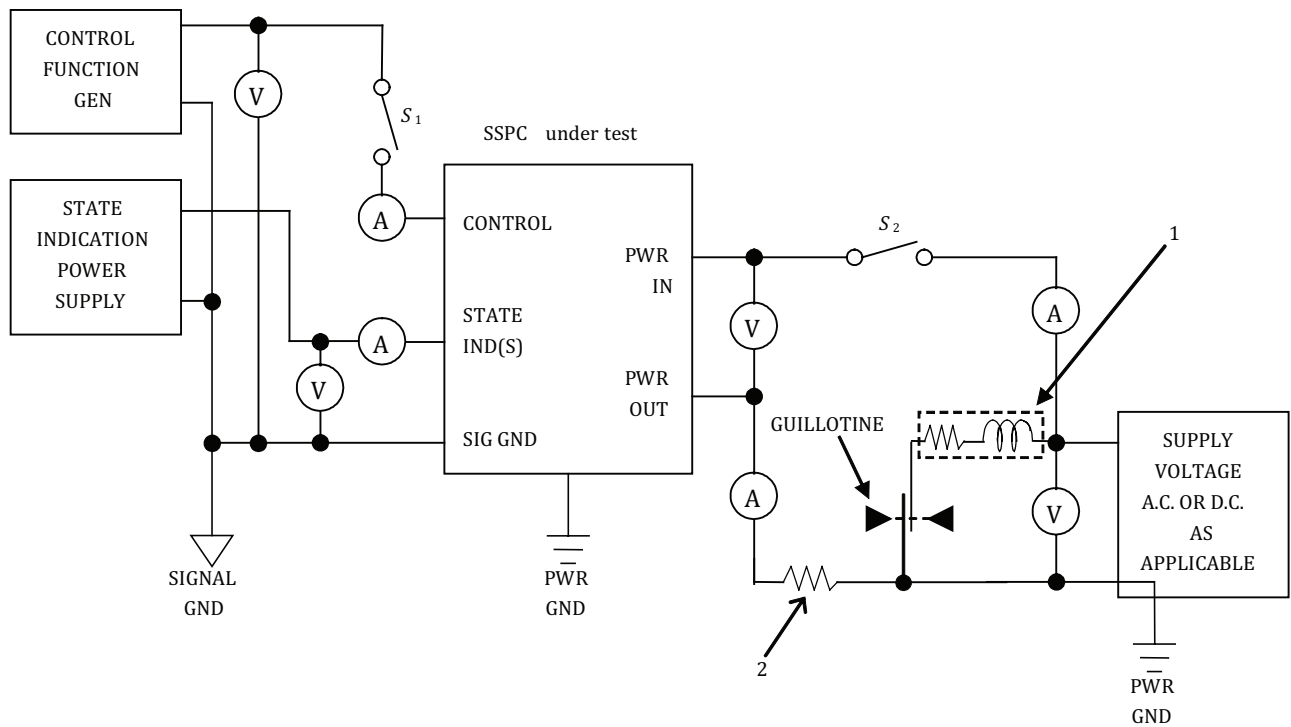

Figure 9 — Compatibility with normal load test circuit



Key

- 1 current limiting wires
- 2 load res.

Figure 10 — Compatibility with fault of another line test circuit

British Standards Institution (BSI)

BSI is the national body responsible for preparing British Standards and other standards-related publications, information and services.

BSI is incorporated by Royal Charter. British Standards and other standardization products are published by BSI Standards Limited.

About us

We bring together business, industry, government, consumers, innovators and others to shape their combined experience and expertise into standards-based solutions.

The knowledge embodied in our standards has been carefully assembled in a dependable format and refined through our open consultation process. Organizations of all sizes and across all sectors choose standards to help them achieve their goals.

Information on standards

We can provide you with the knowledge that your organization needs to succeed. Find out more about British Standards by visiting our website at bsigroup.com/standards or contacting our Customer Services team or Knowledge Centre.

Buying standards

You can buy and download PDF versions of BSI publications, including British and adopted European and international standards, through our website at bsigroup.com/shop, where hard copies can also be purchased.

If you need international and foreign standards from other Standards Development Organizations, hard copies can be ordered from our Customer Services team.

Subscriptions

Our range of subscription services are designed to make using standards easier for you. For further information on our subscription products go to bsigroup.com/subscriptions.

With **British Standards Online (BSOL)** you'll have instant access to over 55,000 British and adopted European and international standards from your desktop. It's available 24/7 and is refreshed daily so you'll always be up to date.

You can keep in touch with standards developments and receive substantial discounts on the purchase price of standards, both in single copy and subscription format, by becoming a **BSI Subscribing Member**.

PLUS is an updating service exclusive to BSI Subscribing Members. You will automatically receive the latest hard copy of your standards when they're revised or replaced.

To find out more about becoming a BSI Subscribing Member and the benefits of membership, please visit bsigroup.com/shop.

With a **Multi-User Network Licence (MUNL)** you are able to host standards publications on your intranet. Licences can cover as few or as many users as you wish. With updates supplied as soon as they're available, you can be sure your documentation is current. For further information, email bsmusales@bsigroup.com.

BSI Group Headquarters

389 Chiswick High Road London W4 4AL UK

Revisions

Our British Standards and other publications are updated by amendment or revision.

We continually improve the quality of our products and services to benefit your business. If you find an inaccuracy or ambiguity within a British Standard or other BSI publication please inform the Knowledge Centre.

Copyright

All the data, software and documentation set out in all British Standards and other BSI publications are the property of and copyrighted by BSI, or some person or entity that owns copyright in the information used (such as the international standardization bodies) and has formally licensed such information to BSI for commercial publication and use. Except as permitted under the Copyright, Designs and Patents Act 1988 no extract may be reproduced, stored in a retrieval system or transmitted in any form or by any means – electronic, photocopying, recording or otherwise – without prior written permission from BSI. Details and advice can be obtained from the Copyright & Licensing Department.

Useful Contacts:

Customer Services

Tel: +44 845 086 9001

Email (orders): orders@bsigroup.com

Email (enquiries): cservices@bsigroup.com

Subscriptions

Tel: +44 845 086 9001

Email: subscriptions@bsigroup.com

Knowledge Centre

Tel: +44 20 8996 7004

Email: knowledgecentre@bsigroup.com

Copyright & Licensing

Tel: +44 20 8996 7070

Email: copyright@bsigroup.com



...making excellence a habit.™