

**Fine ceramics
(advanced ceramics,
advanced technical
ceramics) —
Determination of
coating thickness by
crater-grinding method**

ICS 81.060.30

National foreword

This British Standard is the UK implementation of ISO 26423:2009.

The UK participation in its preparation was entrusted to Technical Committee RPI/13, Advanced technical ceramics.

A list of organizations represented on this committee can be obtained on request to its secretary.

This publication does not purport to include all the necessary provisions of a contract. Users are responsible for its correct application.

Compliance with a British Standard cannot confer immunity from legal obligations.

This British Standard was published under the authority of the Standards Policy and Strategy Committee on 28 February 2009

© BSI 2009

ISBN 978 0 580 58969 0

Amendments/corrigenda issued since publication

Date	Comments

INTERNATIONAL
STANDARD

ISO
26423

First edition
2009-01-15

**Fine ceramics (advanced ceramics,
advanced technical ceramics) —
Determination of coating thickness by
crater-grinding method**

*Céramiques techniques — Détermination de l'épaisseur de revêtement
par la méthode de meulage de cratère*



Reference number
ISO 26423:2009(E)

PDF disclaimer

This PDF file may contain embedded typefaces. In accordance with Adobe's licensing policy, this file may be printed or viewed but shall not be edited unless the typefaces which are embedded are licensed to and installed on the computer performing the editing. In downloading this file, parties accept therein the responsibility of not infringing Adobe's licensing policy. The ISO Central Secretariat accepts no liability in this area.

Adobe is a trademark of Adobe Systems Incorporated.

Details of the software products used to create this PDF file can be found in the General Info relative to the file; the PDF-creation parameters were optimized for printing. Every care has been taken to ensure that the file is suitable for use by ISO member bodies. In the unlikely event that a problem relating to it is found, please inform the Central Secretariat at the address given below.



COPYRIGHT PROTECTED DOCUMENT

© ISO 2009

All rights reserved. Unless otherwise specified, no part of this publication may be reproduced or utilized in any form or by any means, electronic or mechanical, including photocopying and microfilm, without permission in writing from either ISO at the address below or ISO's member body in the country of the requester.

ISO copyright office
Case postale 56 • CH-1211 Geneva 20
Tel. + 41 22 749 01 11
Fax + 41 22 749 09 47
E-mail copyright@iso.org
Web www.iso.org

Published in Switzerland

Contents

Page

Foreword.....	iv
1 Scope	1
2 Normative references	1
3 Symbols	1
4 Principle.....	3
5 Sampling.....	3
6 Test procedure	3
6.1 General.....	3
6.2 Preparation for the test	4
6.3 Test parameters	4
6.4 Example of test parameters.....	5
7 Microscopic examination and measurement.....	5
7.1 Examination.....	5
7.2 Measurement.....	5
8 Calculations.....	6
9 Uncertainty and sources of error	7
10 Test report	7
Annex A (informative) Errors associated with using different formulae for calculating film thickness	9
Annex B (informative) Estimating measurement uncertainty and errors.....	12
Bibliography	15

Foreword

ISO (the International Organization for Standardization) is a worldwide federation of national standards bodies (ISO member bodies). The work of preparing International Standards is normally carried out through ISO technical committees. Each member body interested in a subject for which a technical committee has been established has the right to be represented on that committee. International organizations, governmental and non-governmental, in liaison with ISO, also take part in the work. ISO collaborates closely with the International Electrotechnical Commission (IEC) on all matters of electrotechnical standardization.

International Standards are drafted in accordance with the rules given in the ISO/IEC Directives, Part 2.

The main task of technical committees is to prepare International Standards. Draft International Standards adopted by the technical committees are circulated to the member bodies for voting. Publication as an International Standard requires approval by at least 75 % of the member bodies casting a vote.

Attention is drawn to the possibility that some of the elements of this document may be the subject of patent rights. ISO shall not be held responsible for identifying any or all such patent rights.

ISO 26423 was prepared by Technical Committee ISO/TC 206, *Fine ceramics*.

Fine ceramics (advanced ceramics, advanced technical ceramics) — Determination of coating thickness by crater-grinding method

1 Scope

This International Standard specifies a method for the determination of the thickness of ceramic coatings by a crater-grinding method, which includes the grinding of a spherical cavity and subsequent microscopic examination of the crater.

Because of the uncertainty introduced into the measurement of crater dimensions, the test is not suitable for use where the surface roughness of the coating and/or substrate exceeds 20 % of the coating thickness.

NOTE An alternative method for measurement of thickness, using a contact probe profilometer, is given in ISO 18452.

2 Normative references

The following referenced documents are indispensable for the application of this document. For dated references, only the edition cited applies. For undated references, the latest edition of the referenced document (including any amendments) applies.

ISO 3290-1, *Rolling bearings — Balls — Part 1: Steel balls*

ISO/IEC 17025:2005, *General requirements for the competence of testing and calibration laboratories*

3 Symbols

For the purpose of this document, the following symbols apply.

- D best estimate of the outer diameter of the crater, at the surface of the coating, in micrometres (see Figure 1);
- d best estimate of the inner diameter of the crater, defined by the bottom of the coating layer, in micrometres (see Figure 1);
- h thickness of the coating, in micrometres (see Figure 1);
- m subscript indicating mean value (D_m, d_m, X_m, Y_m).
- r_b radius of the ball, in micrometres (see Figure 1);
- r_s radius of curvature of specimen;
- l_T total penetration depth of the ball, in micrometres (see Figure 1);
- l_t penetration depth of the ball in the substrate, in micrometres (see Figure 1);

- X distance, on a coplanar projection of the two craters, between the periphery of the outer crater and a diametrically equivalent point on the same side of the inner crater, in micrometres (see Figure 1);
- Y distance, on a coplanar projection of the two craters, between the periphery of the outer crater and a diametrically equivalent point on the opposite side of the inner crater, in micrometres (see Figure 1).

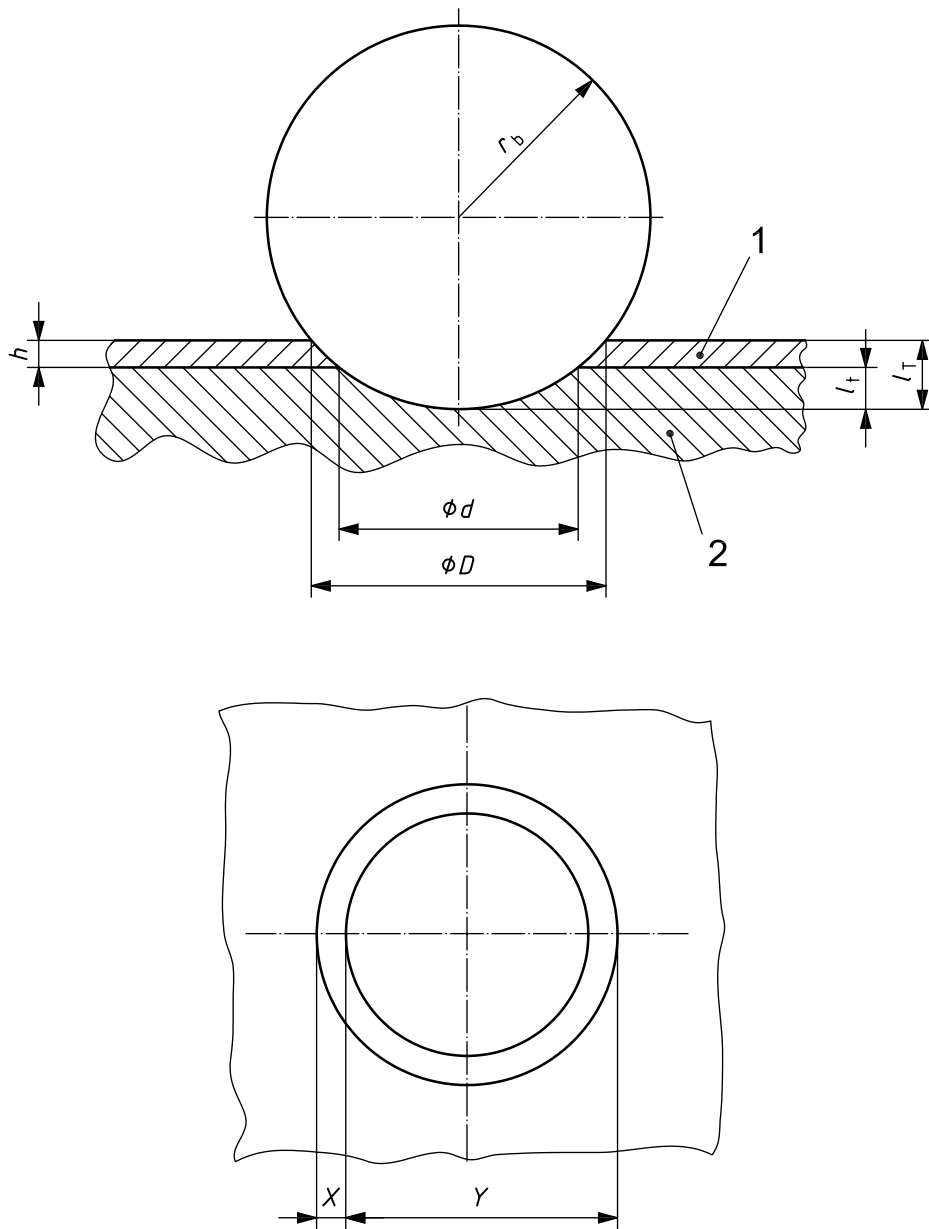

Key

- 1 coating
2 substrate

Figure 1 — Principal dimensions used in the test method

4 Principle

Coating thickness often plays a major role in the performance of coated tools and machine parts. Many different techniques have been developed for assessing the coating thickness. Among these, the crater-grinding method and the step height method (see ISO 18452) are easy to perform and applicable to most coated systems.

The method is simple and straightforward. A crater is ground into the coated part by means of a rotating ball wetted by an abrasive slurry. The thickness of the coating is derived from the ball and crater dimensional characteristics. Contrast between the different materials constituting the coating and substrate is a prerequisite for the method, to enable detection of the interface between the coating and the surface.

Test specimens should be either flat or cylindrical. Flatness can be considered as sufficient if the local specimen radius of curvature, r_s , satisfies the relation $r_s > 100 \times r_b$ (for error $\leq 1\%$).

5 Sampling

A representative test specimen of the product under test shall be used. Test pieces shall be coated original items or, where this is not possible, items made in the same way as the batch to be tested. For large parts, separate manufacturing of the test piece may be necessary.

6 Test procedure

6.1 General

A ball wetted by an abrasive slurry is rotated against the surface of the test piece. A spherical wear crater is produced, and the test is finished when the depth of penetration of the spherical crater is greater than the coating thickness. The coating thickness is then derived from the dimensions of the wear scars (full crater and substrate crater diameters) and the ball diameter.

Different test rig set-ups may be used. The ball can be rotated freely on a drive shaft, whereby its mass is used to produce the contact load, or it may be clamped in the drive axis while the specimen is loaded by means of a lever system. A typical arrangement is shown in Figure 2.

Alternatively, a wheel instead of a ball may be used, in which case the sample shall also be rotated (this is the same principle as used with dimple grinders for the preparation of TEM specimens).

Different abrasives (e.g. diamond, alumina, silica) can be used, and commercially available suspensions based on alcohol, oil or water may be applied. The abrasive slurry may be smeared onto the ball surface prior to testing, but more repeatable measurements are achieved when the abrasive slurry is drip-fed into the contact region, e.g. by peristaltic pumping of a stirred suspension. The grain size of the abrasive shall be small enough to avoid roughening of the crater borders. For example, 1 μm diamond paste suspended in ethanol is often used.

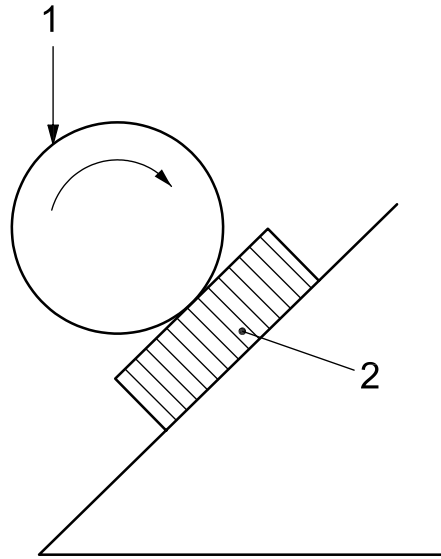

Key

- 1 ball
- 2 specimen

Other orientations may also be used.

Figure 2 — Example of test assembly

6.2 Preparation for the test

Ensure that the specimen and ball are clean. Ultrasonic cleaning for 5 min in fresh petroleum ether followed by drying in ambient air is usually sufficient. The suitability of the ball shall be determined by measuring 10 diameters at random. A ball shall be rejected if the difference between any two measurements exceeds 5 µm (the maximum allowable value of V_{DWS} for grade G 200 balls as given in ISO 3290-1), or if scratches visible to the naked eye are present on the surface. Prepare a slurry of abrasive particles in a diluting agent. Position the test piece on a stable support.

The abrasive slurry should be well stirred to ensure a uniform dispersion of abrasive particles.

Hardened steel balls for rolling bearings, having a specified diameter and surface finish in accordance with ISO 3290-1, can be used.

6.3 Test parameters

The test-specific parameters include:

- a) ball diameter;
- b) contact load;
- c) sliding speed;
- d) composition and concentration of the abrasive suspension;
- e) slurry feed rate;
- f) duration of the test.

The specimen-specific parameters include:

- surface quality (roughness, cleanliness); and
- optical contrast between coating(s) and substrate.

6.4 Example of test parameters

Typical operating parameters are as follows:

- a) ball diameter: 25 mm;
- b) contact load: 0,25 N;
- c) rotational speed of ball: 100 r/min;
- d) composition of the abrasive slurry: 1 µm grain size diamond paste suspended in ethanol, 1:4 concentration
- e) slurry feed rate: 20 drops/min; and
- f) test duration: 5 min.

NOTE Optimum test conditions will differ for different specimens. The above conditions are typical for thin (3 µm to 5 µm thickness) hard coatings on metallic substrates, but will depend on the wear resistance and thickness of the coating, etc. For these and other coatings, it might be necessary to make trial craters under a range of conditions to determine parameters suitable for the production of circular craters of sufficient depth to clearly delineate the substrate/coating interface.

7 Microscopic examination and measurement

7.1 Examination

It is mandatory to clean the specimen prior to examination (see 6.2).

An imaging technique with calibrated size measurement shall be used. Examine the ground cavity at the highest magnification at which the complete worn crater is visible.

Focus the microscope on the concentric patterns and if necessary adjust the illumination to obtain maximum contrast.

Usually an optical reflected-light microscope is used, but any other imaging technique such as scanning electron microscopy may be used, e.g. when it is not possible to discriminate between the coating and the substrate by other means. In the case of optical microscopy, etching may be used to enhance contrast between the substrate and coating.

7.2 Measurement

Measure the crater dimensions as appropriate, using a calibrated measuring device.

For flat specimens, measure the diameters D , d , or lengths X , Y , of the craters both parallel and perpendicular to the direction of ball rotation (Figure 1).

For cylindrical specimens, measure only the largest dimensions of the craters parallel with the cylinder axis (Figure 3).

At least 5 measurements shall be carried out, to define the repeatability of the measurement.

Due to surface roughness effects, the boundaries of the layer(s) may not be well defined and the best estimate of the centreline of a boundary shall be used.

NOTE 1 Dimensions can easily be measured by preparing micrographs of the crater as well as of a traceably calibrated scale at the same magnification.

NOTE 2 The accuracy of the measurement is dependent on the roughness of the surfaces delineating the boundaries of the layer.

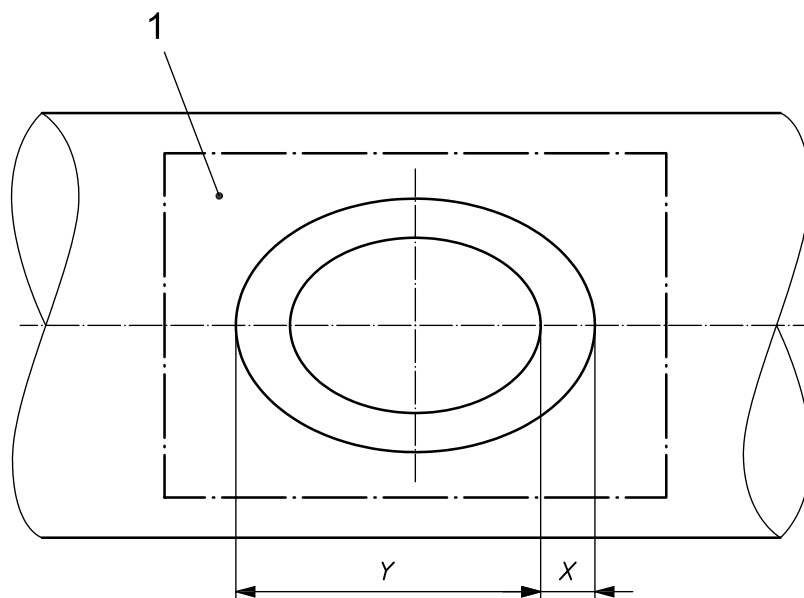

Key

1 enlarged area (microscopical view)

Figure 3 — Cylindrical sample

8 Calculations

The total penetration depth of the spherical crater is calculated using Equation (1):

$$l_T = r_b - \sqrt{r_b^2 - D_m^2 / 4} \tag{1}$$

whereas the penetration depth in the substrate below the coating/substrate interface is given by Equation (2):

$$l_t = r_b - \sqrt{r_b^2 - d_m^2 / 4} \tag{2}$$

The coating thickness can thus be calculated from:

$$h = l_T - l_t \tag{3}$$

or

$$h = \sqrt{r_b^2 - d_m^2 / 4} - \sqrt{r_b^2 - D_m^2 / 4} \tag{4}$$

For thin coatings, the penetration depth is small in comparison to the radius r_b of the ball. Therefore the simplified Equation (5) can be used to determine the thickness:

$$h = \frac{D_m^2 - d_m^2}{8r_b} \quad (5)$$

or, by substituting $D = X + Y$ and $d = Y - X$:

$$h = \frac{X_m Y_m}{2r_b} \quad (6)$$

The use of Equation (5) is preferred, because it is less sensitive to errors in measurement of the crater dimensions (see Annex A).

For specimens not satisfying the flatness criterion $r_s > 100 \times r_b$, Equation (5) should be replaced by:

$$h = \frac{D^2 - d^2}{8} \left[\frac{1}{r_b} + \frac{1}{r_s} \right] \quad (7)$$

Under these circumstances, Equation (6) becomes

$$h = \frac{X_m Y_m}{2} \left[\frac{1}{r_b} + \frac{1}{r_s} \right] \quad (8)$$

NOTE The thickness of individual layers in a multilayer system can be obtained by this method, by applying the above definitions to the inner and outer crater circles defining the layer under investigation.

9 Uncertainty and sources of error

The method described in this International Standard is capable of high accuracy, provided that crater perimeters are both circular and well defined (this requires the surfaces of both the substrate and coatings to be smooth and flat and the crater-grinding to be carried out in a controlled manner), that crater dimensions are accurately measured, and that the radius of curvature of the crater is equal to that of the ball producing it. Uncertainty in the crater dimensions, deviations from roundness, and differences between the radius of curvature of the crater and that of the ball are likely to be the biggest sources of uncertainty in the test method. These three sources of uncertainty and error are discussed further in Annex B.

10 Test report

The results shall be reported in accordance with ISO/IEC 17025, and the test report shall include at least the following information:

- a) the name of the testing establishment;
- b) date of the test, report identification and number, signatory;
- c) a reference to this International Standard, i.e. "determined in accordance with ISO 26423";
- d) a description of the test material: type of product, type of coating, date of receipt;
- e) method of test specimen sampling and preparation;
- f) test parameters;

- g) test results;
- h) test uncertainty, taking into account the information in Annex B;
- i) comments about the test or the test results;
- j) if micrographs are used, the magnification of the micrograph and a micrograph of a traceably calibrated scale, taken at the same magnification, to indicate the scale whatever reduction may be adopted during the course of evaluation.

Annex A (informative)

Errors associated with using different formulae for calculating film thickness

Equations (5) and (6) are given in Clause 7 for the measurement of a coating thickness h by the crater-grinding method:

$$\text{Equation (5): } h = \frac{D_m^2 - d_m^2}{8r_b}$$

$$\text{Equation (6): } h = \frac{X_m Y_m}{2r_b}$$

where r_b is the radius of the ball.

In order to evaluate the influence of measurement errors on the calculated thickness, Equations (5) and (6) have to be rewritten as functions of the (measured) coordinates x_1 , x_2 , x_3 and x_4 as shown in Figure A.1.

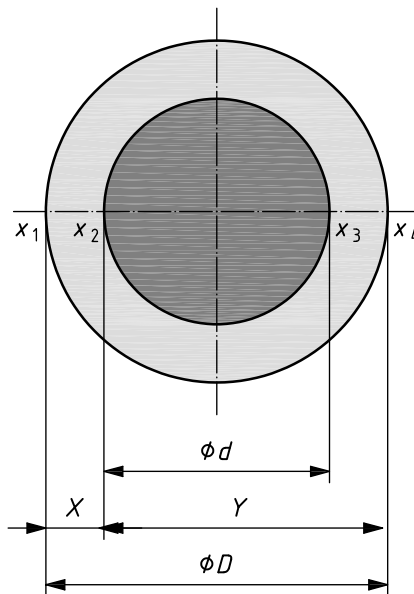

Figure A.1 — Crater produced by crater-grinding

$$D = x_4 - x_1 = X + Y$$

$$d = x_3 - x_2 = Y - X$$

$$X = x_2 - x_1 = \frac{D - d}{2}$$

$$Y = x_4 - x_2 = \frac{D + d}{2}$$

The variance of h can now be derived as a function of the variances of x_1 , x_2 , x_3 and x_4 .

Let the variance of h when using Equation (5) be $\sigma_{(5)}(h)$:

$$h = \frac{(x_4 - x_1)^2 - (x_3 - x_2)^2}{8r_b}$$

$$\sigma_{(5)}^2(h) = \left(\frac{1}{8r_b}\right)^2 \left\{ [2(x_4 - x_1)]^2 \sigma^2(x_1) + [2(x_3 - x_2)]^2 \sigma^2(x_2) + [2(x_3 - x_2)]^2 \sigma^2(x_3) + [2(x_4 - x_1)]^2 \sigma^2(x_4) \right\}$$

Assume now that $\sigma(x_1) = \sigma(x_4) = \sigma$, and

$$\sigma(x_2) = \sigma(x_3) = \alpha\sigma$$

It could be that $\sigma(x_2)$ and $\sigma(x_3)$ are somewhat different from $\sigma(x_1)$ and $\sigma(x_4)$. For example, it might be more difficult to distinguish the exact interface between coating and substrate. Therefore we introduced the factor α . A more simplified assumption is $\alpha = 1$, but it should be noted that α can also take values of less than and greater than 1.

The variance $\sigma_{(5)}(h)$ can now be expressed as:

$$\sigma_{(5)}(h) = \left(\frac{1}{4r_b}\right) (2D^2 + 2\alpha^2 d^2)^{1/2} \sigma$$

When $\alpha = 1$, then:

$$\sigma_{(5)}(h) = \left(\frac{1}{4r_b}\right) (2D^2 + 2d^2)^{1/2} \sigma$$

Let now the variance of h when using Equation (6) be $\sigma_{(6)}(h)$:

$$h = \frac{(x_2 - x_1)(x_4 - x_2)}{2r_b}$$

$$\sigma_{(6)}^2(h) = \left(\frac{1}{2r_b}\right)^2 \left\{ (x_4 - x_2)^2 \sigma^2(x_1) + (x_2 - x_1)^2 \sigma^2(x_4) + [(x_4 - x_2) - (x_2 - x_1)]^2 \sigma^2(x_2) \right\}$$

With the same assumptions as above for the variances of x_1, x_2, x_3 and x_4 , we can now write:

$$\sigma_{(6)}(h) = \left(\frac{1}{2r_b}\right) [X^2 + Y^2 + \alpha^2(Y - X)^2]^{1/2} \sigma$$

When $\alpha = 1$, then:

$$\sigma_{(6)}(h) = \left(\frac{1}{2r_b}\right) (2X^2 + 2Y^2 - 2XY)^{1/2} \sigma$$

In terms of D and d , the equation becomes:

$$\sigma_{(6)}(h) = \left(\frac{1}{4r_b}\right) [2D^2 + 2(1 + \alpha^2)d^2]^{1/2} \sigma$$

Now the ratio of $\sigma_{(6)}(h)$ to $\sigma_{(5)}(h)$ is:

$$\frac{\sigma_{(6)}(h)}{\sigma_{(5)}(h)} = \frac{\left[D^2 + (1 + \alpha^2) d^2 \right]^{1/2}}{\left(D^2 + \alpha^2 d^2 \right)^{1/2}}$$

When $\alpha = 1$, then:

$$\frac{\sigma_{(6)}(h)}{\sigma_{(5)}(h)} = \frac{\left(D^2 + 2 d^2 \right)^{1/2}}{\left(D^2 + d^2 \right)^{1/2}}$$

This ratio is always > 1 for all values of α , which means that the variance of h when using Equation (6) is higher than when using Equation (5).

Annex B (informative)

Estimating measurement uncertainty and errors

B.1 General

Three situations are considered:

- a) measurement uncertainty resulting from uncertainty in determination of the crater diameters in the coating and substrate;
- b) measurement uncertainty associated with the radius of curvature of the crater differing from the radius of the ball used to produce it;
- c) measurement uncertainty resulting from a non-circular crater.

B.2 Uncertainty resulting from uncertainty in determination of the crater diameters in the coating and substrate

Using the simplified equation for the coating thickness, h , i.e.

$$h = \frac{D^2 - d^2}{4\phi} \quad (\text{B.1})$$

where ϕ is the diameter of the ball ($= 2r_b$)

and assuming an uncertainty in the measurement of D and d of $\pm x \mu\text{m}$, leads to an uncertainty in h of:

$$\pm \frac{(D+d)x}{2\phi} \quad (\text{B.2})$$

For a fixed value of h , as D increases d also increases, hence $(D+d)$ also increases and the uncertainty in h increases. Hence the smallest uncertainty in h occurs when $d=0$, i.e. when the crater just penetrates the coating. In practice, the inner crater needs to attain a well-defined circular shape so d will always be > 0 . The uncertainty should be estimated from the uncertainty in the values of D and d , and used in the estimation of the overall uncertainty of the measured value of the coating thickness.

B.3 Uncertainty associated with radius of curvature of crater differing from radius of ball used to produce it

Assume the diameter of curvature of the crater is given by:

$$\phi_a = \phi_t(1+x) \quad (\text{B.3})$$

where

ϕ_a is the actual value of the diameter of curvature of crater;

ϕ_t is the true diameter of ball;

x is the fractional difference between the actual diameter of curvature of the crater and the true diameter of the ball.

The percentage error in the value of h is given by Equation (B.4):

$$\left(\frac{h_{\text{cal}} - h_t}{h_t} \right) \times 100 \quad (\text{B.4})$$

where

h_{cal} is the calculated coating thickness;

h_t is the true coating thickness.

Substituting the values of

$$h_{\text{cal}} = \frac{(D_m^2 - d_m^2)}{4\phi_t} \quad (\text{B.5})$$

and

$$h_t = \frac{(D_m^2 - d_m^2)}{4\phi_t(1+x)} \quad (\text{B.6})$$

into the above Equation (B.4) gives the percentage error in the value of h as x , where x is the fractional discrepancy between the diameter of curvature of the crater and the diameter of curvature of the ball.

Hence if $x = 0,1$, then the uncertainty in $h = 10\%$ of h_t , i.e. the percentage error in h is the same as that in the assumption that $\phi_a = \phi_t$. In this case, determination of the uncertainty in the measured value of h will require an accurate measurement of the diameter of curvature of the crater, which can only be achieved by the use of a (scanning) profilometer. An alternative method would be to measure the depth, l_T , of the crater below the surface of the coating and to calculate the diameter of curvature of the crater using this figure and the diameter of the crater. However, readily available depth-measuring instruments, including depth-measuring microscopes, are insufficiently sensitive to provide the necessary accuracy.

EXAMPLE A crater $7\ \mu\text{m}$ deep produced by a $25\ \text{mm}$ diameter ball would have a diameter of $0,836\ \text{mm}$. If the diameter of curvature of the crater were 10% greater than that of the ball (i.e. $27,5\ \text{mm}$), the crater diameter would be $0,878\ \text{mm}$. This would result in a 10% error in the thickness of the coating, irrespective of coating thickness. However, a $42\ \mu\text{m}$ uncertainty ($\pm 21\ \mu\text{m}$) in the diameter of the crater (with the correct diameter of curvature) would result in an error that varies with coating thickness. For a coating of $7\ \mu\text{m}$ thickness the error would be $\pm 0,3\ \mu\text{m}$ (i.e. less than 5%), whereas for a coating of $4\ \mu\text{m}$ thickness the error would be $\pm 0,5\ \mu\text{m}$ (i.e. $12,5\%$).

B.4 Uncertainty resulting from a non-circular crater

Assume the crater is elliptical in the direction of rotation of the ball and circular in the direction perpendicular to this. Also assume that the radius of curvature of the crater in the direction perpendicular to the ball rotation is equal to the radius of curvature of the ball. Let the crater dimensions parallel to the ball rotation direction equal D_r and d_r and those perpendicular to the direction of ball rotation equal D_p and d_p . Assume $D_r = D_p(1+x)$ and $d_r = d_p(1+x)$. Then by taking the average of the measured values of D_r and D_p ($= D_{\text{meas}}$) and d_r and d_p ($= d_{\text{meas}}$) we have:

$$D_{\text{meas}} = D_p(1+0,5x) \quad (\text{B.7})$$

and

$$d_{\text{meas}} = d_p(1+0,5x) \quad (\text{B.8})$$

Substituting these values into the equation for the percentage error in h_{cal} and neglecting terms in x^2 gives the percentage error in the value of h as x .

Hence where crater dimensions in the parallel and perpendicular directions differ by more than 10 %, the error in the coating thickness will also exceed 10 % and it is appropriate to eliminate such craters from the test.

Bibliography

- [1] ISO 18452, *Fine ceramics (advanced ceramics, advanced technical ceramics) — Determination of thickness of ceramic films by contact-probe profilometer*

BSI - British Standards Institution

BSI is the independent national body responsible for preparing British Standards. It presents the UK view on standards in Europe and at the international level. It is incorporated by Royal Charter.

Revisions

British Standards are updated by amendment or revision. Users of British Standards should make sure that they possess the latest amendments or editions.

It is the constant aim of BSI to improve the quality of our products and services. We would be grateful if anyone finding an inaccuracy or ambiguity while using this British Standard would inform the Secretary of the technical committee responsible, the identity of which can be found on the inside front cover. Tel: +44 (0)20 8996 9000. Fax: +44 (0)20 8996 7400.

BSI offers members an individual updating service called PLUS which ensures that subscribers automatically receive the latest editions of standards.

Buying standards

Orders for all BSI, international and foreign standards publications should be addressed to Customer Services. Tel: +44 (0)20 8996 9001. Fax: +44 (0)20 8996 7001 Email: orders@bsigroup.com You may also buy directly using a debit/credit card from the BSI Shop on the Website <http://www.bsigroup.com/shop>

In response to orders for international standards, it is BSI policy to supply the BSI implementation of those that have been published as British Standards, unless otherwise requested.

Information on standards

BSI provides a wide range of information on national, European and international standards through its Library and its Technical Help to Exporters Service. Various BSI electronic information services are also available which give details on all its products and services. Contact Information Centre. Tel: +44 (0)20 8996 7111 Fax: +44 (0)20 8996 7048 Email: info@bsigroup.com

Subscribing members of BSI are kept up to date with standards developments and receive substantial discounts on the purchase price of standards. For details of these and other benefits contact Membership Administration. Tel: +44 (0)20 8996 7002 Fax: +44 (0)20 8996 7001 Email: membership@bsigroup.com

Information regarding online access to British Standards via British Standards Online can be found at <http://www.bsigroup.com/BSOL>

Further information about BSI is available on the BSI website at <http://www.bsigroup.com>

Copyright

Copyright subsists in all BSI publications. BSI also holds the copyright, in the UK, of the publications of the international standardization bodies. Except as permitted under the Copyright, Designs and Patents Act 1988 no extract may be reproduced, stored in a retrieval system or transmitted in any form or by any means – electronic, photocopying, recording or otherwise – without prior written permission from BSI.

This does not preclude the free use, in the course of implementing the standard, of necessary details such as symbols, and size, type or grade designations. If these details are to be used for any other purpose than implementation then the prior written permission of BSI must be obtained.

Details and advice can be obtained from the Copyright and Licensing Manager. Tel: +44 (0)20 8996 7070 Email: copyright@bsigroup.com