

Tractors for agriculture and forestry — Safety

Part 1: Standard tractors

Licensed Copy: :FULLNAME, : DATE, Uncontrolled Copy, (c) BSI

ICS 65.060.10

National foreword

This British Standard is the UK implementation of ISO 26322-1:2008.

The UK participation in its preparation was entrusted to Technical Committee AGE/6, Agricultural tractors and forestry machinery.

A list of organizations represented on this committee can be obtained on request to its secretary.

This publication does not purport to include all the necessary provisions of a contract. Users are responsible for its correct application.

Compliance with a British Standard cannot confer immunity from legal obligations.

Licensed Copy: :FULLNAME, : DATE, Uncontrolled Copy, (c) BSI

This British Standard was published under the authority of the Standards Policy and Strategy Committee on 30 November 2008

© BSI 2008

ISBN 978 0 580 58317 9

Amendments/corrigenda issued since publication

Date	Comments

INTERNATIONAL STANDARD

ISO
26322-1

First edition
2008-10-15

Tractors for agriculture and forestry — Safety —

Part 1: Standard tractors

Tracteurs agricoles et forestiers — Sécurité —

Partie 1: Tracteurs standards



Reference number
ISO 26322-1:2008(E)

PDF disclaimer

This PDF file may contain embedded typefaces. In accordance with Adobe's licensing policy, this file may be printed or viewed but shall not be edited unless the typefaces which are embedded are licensed to and installed on the computer performing the editing. In downloading this file, parties accept therein the responsibility of not infringing Adobe's licensing policy. The ISO Central Secretariat accepts no liability in this area.

Adobe is a trademark of Adobe Systems Incorporated.

Details of the software products used to create this PDF file can be found in the General Info relative to the file; the PDF-creation parameters were optimized for printing. Every care has been taken to ensure that the file is suitable for use by ISO member bodies. In the unlikely event that a problem relating to it is found, please inform the Central Secretariat at the address given below.



COPYRIGHT PROTECTED DOCUMENT

© ISO 2008

All rights reserved. Unless otherwise specified, no part of this publication may be reproduced or utilized in any form or by any means, electronic or mechanical, including photocopying and microfilm, without permission in writing from either ISO at the address below or ISO's member body in the country of the requester.

ISO copyright office
Case postale 56 • CH-1211 Geneva 20
Tel. + 41 22 749 01 11
Fax + 41 22 749 09 47
E-mail copyright@iso.org
Web www.iso.org

Published in Switzerland

Contents

Page

Foreword.....	iv
1 Scope	1
2 Normative references	1
3 Terms and definitions	2
4 Safety requirements	3
5 Information for use	10
Bibliography	12

Foreword

ISO (the International Organization for Standardization) is a worldwide federation of national standards bodies (ISO member bodies). The work of preparing International Standards is normally carried out through ISO technical committees. Each member body interested in a subject for which a technical committee has been established has the right to be represented on that committee. International organizations, governmental and non-governmental, in liaison with ISO, also take part in the work. ISO collaborates closely with the International Electrotechnical Commission (IEC) on all matters of electrotechnical standardization.

International Standards are drafted in accordance with the rules given in the ISO/IEC Directives, Part 2.

The main task of technical committees is to prepare International Standards. Draft International Standards adopted by the technical committees are circulated to the member bodies for voting. Publication as an International Standard requires approval by at least 75 % of the member bodies casting a vote.

Attention is drawn to the possibility that some of the elements of this document may be the subject of patent rights. ISO shall not be held responsible for identifying any or all such patent rights.

ISO 26322-1 was prepared by Technical Committee ISO/TC 23, *Tractors and machinery for agriculture and forestry*, Subcommittee SC 4, *Tractors*.

This first edition of ISO 26322-1 cancels and replaces ISO 4254-3:1992, of which it constitutes a technical revision. Additional requirements have been included in order to take account of the technical evolution of the tractors and changes in their use that have occurred since publication of the replaced International Standard.

ISO 26322 consists of the following parts, under the general title *Tractors for agriculture and forestry — Safety*:

- *Part 1: Standard tractors*
- *Part 2: Narrow-track and small tractors*

Tractors for agriculture and forestry — Safety —

Part 1: Standard tractors

1 Scope

This part of ISO 26322 specifies general safety requirements and their verification for the design and construction of standard tractors used in agriculture and forestry. These tractors have at least two axles for pneumatic-tyred wheels, with the smallest track gauge of the rear axle exceeding 1 150 mm, or tracks instead of wheels, with their unballasted tractor mass being greater than 600 kg.

NOTE Tractors having an unballasted mass not greater than 600 kg and a smallest adjustable track gauge of the axle bearing the larger tyres of $\leq 1\ 150$ mm are dealt with in ISO 26322-2.

In addition, this part of ISO 26322 specifies the type of information on safe working practices (including residual risks) to be provided by the manufacturer, as well as technical means for improving the degree of personal safety of the operator and others involved in a tractor's normal operation, maintenance and use.

It is not applicable to vibration or braking.

2 Normative references

The following referenced documents are indispensable for the application of this document. For dated references, only the edition cited applies. For undated references, the latest edition of the referenced document (including any amendments) applies.

ISO 500-1, *Agricultural tractors — Rear-mounted power take-off types 1, 2 and 3 — Part 1: General specifications, safety requirements, dimensions for master shield and clearance zone*

ISO 3463, *Tractors for agriculture and forestry — Roll-over protective structures (ROPS) — Dynamic test method and acceptance conditions*

ISO 3600, *Tractors, machinery for agriculture and forestry, powered lawn and garden equipment — Operator's manuals — Content and presentation*

ISO 3776-1, *Tractors and machinery for agriculture — Seat belts — Part 1: Anchorage location requirements*

ISO 3776-2, *Tractors and machinery for agriculture — Seat belts — Part 2: Anchorage strength requirements*

ISO/OECD 3776-3, *Tractors and machinery for agriculture — Seat belts — Part 3: Requirements for assemblies*¹⁾

ISO 3795, *Road vehicles, and tractors and machinery for agriculture and forestry — Determination of burning behaviour of interior materials*

ISO 4252, *Agricultural tractors — Operator's workplace, access and exit — Dimensions*

1) To be published.

ISO 4413:1998, *Hydraulic fluid power — General rules relating to systems* ²⁾

ISO 5131:1996, *Acoustics — Tractors and machinery for agriculture and forestry — Measurement of noise at the operator's position — Survey method*

ISO 5700, *Tractors for agriculture and forestry — Roll-over protective structures (ROPS) — Static test method and acceptance conditions*

ISO 7216, *Acoustics — Agricultural and forestry wheeled tractors and self-propelled machines — Measurement of noise emitted when in motion*

ISO 8759-1, *Agricultural wheeled tractors — Front-mounted equipment — Part 1: Power take-off and three-point linkage*

ISO 10998, *Agricultural tractors — Requirements for steering*

ISO 11684, *Tractors, machinery for agriculture and forestry, powered lawn and garden equipment — Safety signs and hazard pictorials — General principles*

ISO 12100-1:2003, *Safety of machinery — Basic concepts, general principles for design — Part 1: Basic terminology, methodology*

ISO 13854:1996, *Safety of machinery — Minimum gaps to avoid crushing of parts of the human body*

ISO 13857:2008, *Safety of machinery — Safety distances to prevent hazard zones being reached by upper and lower limbs*

ISO 15077, *Tractors and self-propelled machinery for agriculture — Operator controls — Actuating forces, displacement, location and method of operation*

ISO 23205, *Agricultural tractors — Instructional seat*

3 Terms and definitions

For the purposes of this document, the following terms and definitions apply.

3.1 normal operation and service
use of the tractor for the purpose intended by the manufacturer by an operator familiar with the tractor characteristics and complying with the information for operation, service and safe practices, as specified by the manufacturer in the operator's manual and by signs on the tractor

3.2 three-point contact support
system which permits a person to simultaneously use two hands and a foot or two feet and one hand when boarding, or dismounting from, a tractor

3.3 guarded by location
guarding where a hazard is guarded by other parts or components of the tractor that are not themselves guards, or when the hazard cannot be reached by the upper and lower limbs

2) Under revision.

3.4

inadvertent contact

unplanned exposure of a person to a hazard resulting from the person's action during normal operation and service of the tractor

3.5

hazard

machinery parts which can cause injury upon direct contact or by entanglement of personal apparel

NOTE These parts include, but are not limited to, pinch points, nip points, and projections on rotating parts.

4 Safety requirements

4.1 Fundamental principles, design guidance

4.1.1 The tractor shall be designed according to the principles of risk reduction specified in ISO 12100-1:2003, Clause 5, for hazards relevant but not significant.

4.1.2 Unless specified otherwise in this part of ISO 26322, safety distances shall be in accordance with ISO 13857:2008, Tables 1, 3, 4 and 6, and ISO 13854:1996, Table 1, as appropriate.

4.1.3 Tractor engine cover(s) that can be opened without tools may be considered an acceptable guard for rotating components provided that the engine cover is removable from the tractor only by the use of tools.

4.2 Noise

4.2.1 Noise at the operator's position

Noise tests and measurements shall be made in accordance with ISO 5131.

NOTE ISO 5131:1996, Annex A, gives procedures specific to agricultural and forestry tractors.

4.2.2 Noise emitted when in motion

Noise tests and measurements shall be made in accordance with ISO 7216.

4.3 Controls

4.3.1 General

4.3.1.1 Controls such as steering wheels or steering levers, gear levers, control levers, cranks, pedals and switches shall be chosen, designed, constructed and arranged so that their locations and methods of operation are in accordance with ISO 15077.

4.3.1.2 Hand-operated controls shall have minimum clearances in accordance with ISO 4252. This requirement does not apply to fingertip operation controls, such as push-buttons, electric switches.

4.3.2 Starting and stopping the engine

4.3.2.1 A means shall be provided to enable prevention of inadvertent and/or unauthorized starting of the engine. Examples of such means include but are not limited to:

- an ignition or start switch with a removable key;
- a lockable cab;
- a lockable cover over the ignition or start switch;

- a security ignition or starting lock (e.g. key card activated);
- a lockable battery disconnect switch.

4.3.2.2 Tractors equipped with starter interlocks as per ISO 15077 on only the traction control clutch or combination traction clutch and brake control shall include means to prevent the operator from starting the tractor from the ground while, for example, holding the control(s) disengaged by hand.

4.3.2.3 It shall not be possible to start the engine with the PTO (power take-off) activated.

A means shall be provided which prevents the PTO shaft from transmitting torque at engine start-up.

EXAMPLE 1 An interlock switch which prevents engine cranking when the PTO control is in the run position.

EXAMPLE 2 PTO clutch left disengaged until engagement is commanded after engine start.

4.3.2.4 Starting the engine shall not move the three-point linkage.

4.3.3 External control(s) for three-point linkage

4.3.3.1 External controls for either the front or rear three-point linkage shall operate under either one or the other of the following limitations:

- movement of the linkage, as measured at the lower hitch points, shall be limited to a maximum of 100 mm for each activation of the control;
- movement of the linkage shall occur only while the control is held in the activation position.

4.3.3.2 External controls shall be located such that the operator can activate them while standing on the ground outside of the hazard zone between the tractor and the implement. This does not apply to external control system measures that eliminate or minimize the risks. For example, a control may be achieved by limiting the maximum rate of travel of the three-point hitch linkage.

The preferred maximum height of the control(s) above the ground is 1 800 mm, or 2 000 mm if technically justified.

4.3.3.3 Provision shall be made to prevent unintentional actuation of control(s).

4.3.3.4 Other arrangements are permitted provided they have an effect at least equivalent to the requirements set out in 4.3.3.1, 4.3.3.2 and 4.3.3.3.

4.3.4 PTO external control(s)

4.3.4.1 The driver shall be able to operate the control(s) from a location which allows the operator to avoid contact with the PTO shaft or the IID (implement input device) and which also allows the operator to verify that no person is in a hazardous location between the tractor and attached implement. The height of control(s) above the ground shall not exceed 2 000 mm.

4.3.4.2 Provision shall be made to prevent unintentional engagement of the PTO clutch. The control or controls shall be clearly identified and shall not be subject to confusion with other external control(s), if provided (e.g. three-point linkage control or controls).

4.3.4.3 The start control shall work according to the “hold-to-run principle” for at least the first 3 s of actuation.

4.3.4.4 Engagement of the PTO using the external control(s) shall occur with no delay greater than that experienced when using the main PTO control.

4.3.4.5 It shall always be possible to shut off the PTO(s) from the operator's seat position as well as from the associated external control(s).

4.3.5 Pedals

Pedals shall have an appropriate size, space and be adequately spaced. Pedals shall have a slip-resistant surface and shall be easy to clean.

In order to avoid confusing the driver, the pedals (clutch, brake and accelerator) shall have the same function and arrangement as those of a motor vehicle.

4.4 Operator station

4.4.1 Boarding means

4.4.1.1 General

4.4.1.1.1 If the vertical height of the operator station floor above ground level exceeds 550 mm, when measured on level ground, with the tyres as specified, of maximum diameter and at the specified inflation pressure, or with the largest tracks, a boarding means shall be provided. The dimensions shall be as shown in Figure 1 or Figure 2 and as specified in 4.4.1.2.

4.4.1.1.2 Shielding shall be provided on the back of steps or ladders if a protruding hand or foot may contact a hazardous part of the tractor, e.g. wheel or track.

Dimensions in millimetres

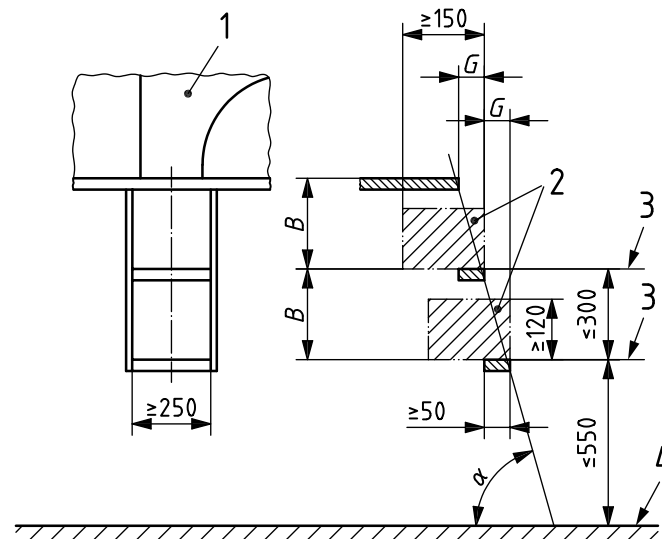

Key

- 1 exit
- 2 clearance zone
- 3 upper edge of step
- 4 ground
- B* vertical distance between steps
- G* horizontal distance between steps

A width of less than 250 mm may be used only if justified for technical reasons. Where this is the case, the aim should be to achieve the greatest width practicable. In no case shall the width be less than 150 mm.

Figure 1 — Dimensions of boarding means for operator stations

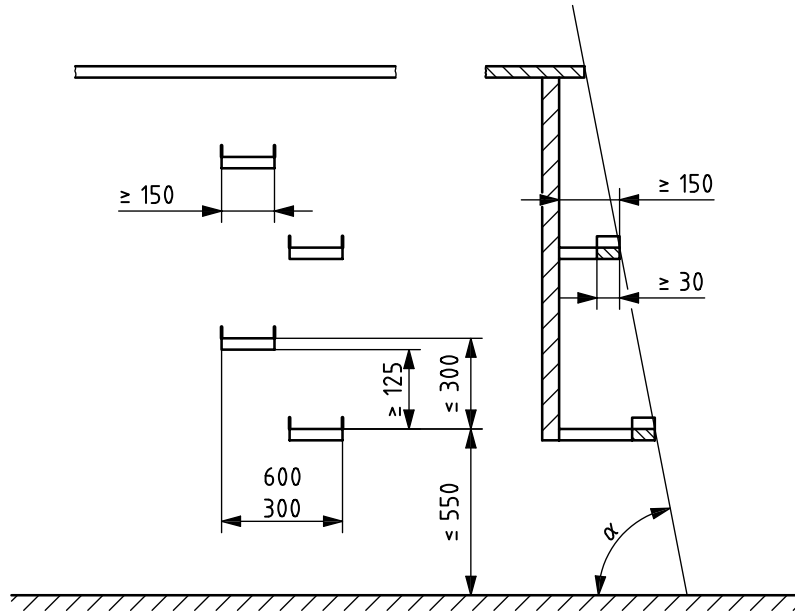

Figure 2 — Dimensions of boarding means for operator stations for single foot placement

4.4.1.2 Steps and ladders

4.4.1.2.1 The height of the first step shall be achieved with tyres as specified, of the maximum diameter and at the specified inflation pressure, or with the largest tracks. The vertical distance between successive steps shall be equal, within a tolerance of ± 20 mm. The vertical distance between the top step and the operator platform may vary as necessary but shall not exceed 300 mm. Each step shall have a slip-resistant surface, a lateral stop at each end and be so designed (e.g. mudguards, perforated steps) that an accumulation of mud and/or snow is minimized under normal working conditions. A flexible connection or connections between the first and second steps are permitted.

If track systems are used as steps, the riser height from the track to the platform may be up to 500 mm.

4.4.1.2.2 If ladders are used, their inclination, α , shall be between 70° and 90° from the horizontal.

4.4.1.2.3 Boarding means having an inclination, α , from the horizontal of less than 70° shall be in accordance with Figure 1 and the sum of $2B + G$ shall be ≤ 700 mm, where B is the vertical distance and G the horizontal distance between steps.

4.4.1.2.4 If parts of the boarding means are moveable, the manual operating force shall not exceed 200 N as the average value when moving from the start to the stop position. The peak(s) shall not exceed 400 N.

4.4.1.2.5 When moving the boarding means, there shall be no shearing, pinching or uncontrollable movement hazards to the operator.

4.4.1.2.6 Where, on tracked machines, the track shoes and track pad surfaces are intended to be used as access steps, the design of the track shoes and track pads shall take into account the need for a slip-resistant surface.

4.4.1.3 Handrails/handholds

4.4.1.3.1 Handrails or handholds shall be provided so that the operator can maintain three-point contact support while accessing or exiting the operator's station. The lower end of the handrail/handhold shall be located no higher than 1 500 mm from the ground surface. A minimum clearance of 30 mm shall be provided for hand clearance between the handrail/handhold and the adjacent parts (except at attaching points).

4.4.1.3.2 A handrail or handhold shall be provided above the uppermost step/rung of the boarding means at a height between 850 mm and 1 100 mm. The handhold on tractors shall be at least 110 mm long.

4.4.2 Operator's workplace

4.4.2.1 The operator's workplace, access and exit dimensions shall comply with requirements of ISO 4252.

4.4.2.2 There shall be no shearing or crushing points within hand or foot reach of the operator when seated in the seat provided.

4.4.2.3 The foot reach of the operator is defined by a hemisphere of 800 mm radius centred on the seat centreline at the front edge of the cushion and extending downwards, with the seat in its central position.

The hand reach of the operator is divided into the spherical volumes A and B, as shown in Figure 3. The spherical centre-point of these volumes is located 60 mm in front and 580 mm above the seat index point (SIP) (see Figure 3). Volume A is formed by a spherical radius of 550 mm, while volume B is the volume between this radius and a spherical radius of 1 000 mm.

Within volume A, a minimum clearance of 120 mm between power and inertia-operated and other adjacent parts shall be maintained. Within volume B, a minimum clearance of 25 mm shall be maintained. Within both volumes, a minimum angle of 30° shall be maintained where parts shear against each other.

The hand and foot reach for tractors equipped with a cab is limited to those portions of the volumes specified that lie within the cab.

Dimensions in millimetres

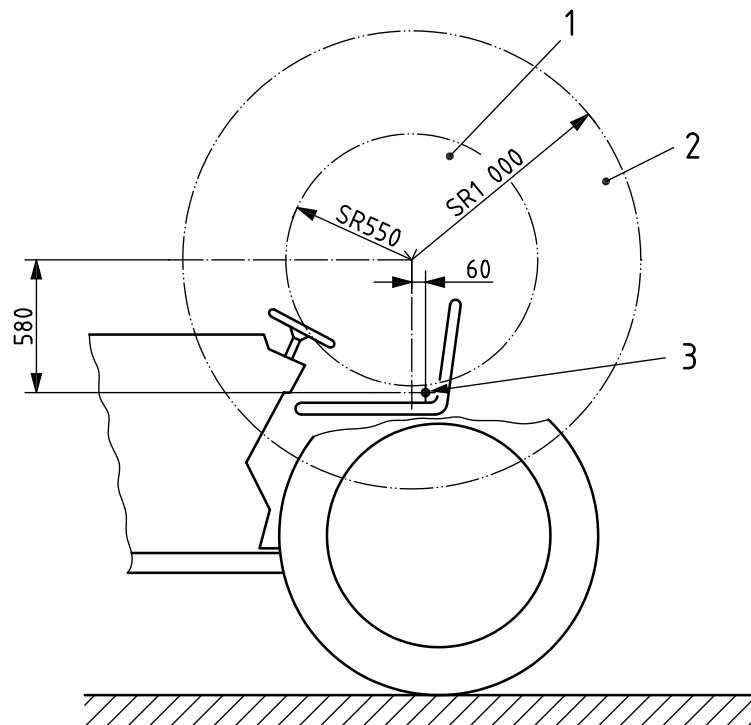

Key

- 1 volume A
- 2 volume B
- 3 SIP (see ISO 5353)

Figure 3 — Operator's hand reach

4.4.3 Operator's seat

A seat shall be provided that supports the operator in all working and operating modes. Information on the seat adjustment shall be provided in the operator's manual. Additionally, a seat belt that meets the requirements of ISO 3776-1, ISO 3776-2 and ISO/OECD 3776-3 shall be provided.

4.4.4 Instructional seat

An instructional seat, if provided, shall meet the requirements of ISO 23205.

4.4.5 Cab material burning rate

The burning rate of cab interior material such as the seat covering, wall, floor and headliner coverings when provided shall not exceed the maximum rate of 150 mm/min when tested in accordance with ISO 3795.

4.5 Power take-off (PTO)

4.5.1 PTO guarding and clearance

The rear-mounted PTO shall be in accordance with ISO 500-1. The front-mounted PTO shall be in accordance with ISO 8759-1. Additionally, any components of the tractor not addressed in ISO 500-1 or ISO 8759-1 that transmit power to the PTO shall be guarded by location (see 4.1.2), by safety distances, or with guard(s).

4.6 Strength requirements for guards and barriers

4.6.1 Guards and barriers, and in particular barriers with a vertical height from the ground of up to 550 mm, shall be designed to withstand a vertical load of 1 200 N, unless the guards/barriers are designed in such a way that they cannot be used as a step.

4.6.2 Barriers used as protection against hazards related to moving working parts shall withstand the following horizontal loads:

- 1 000 N, up to 400 mm from the ground in the working position;
- 600 N, above 400 mm from the ground in the working position.

4.7 Electrical equipment

4.7.1 Electrical cables shall be protected if located in potentially abrasive contact with surfaces and shall be resistant to, or protected against, contact with lubricant or fuel. Electrical cables shall be located so that no portion is in contact with the exhaust system, moving parts or sharp edges.

4.7.2 Fuses or other overload protection devices shall be installed in all electrical circuits except for high amperage circuits such as the starter-motor circuit and high-tension spark ignition system. Electrical distribution of these devices between circuits shall prevent the possibility of cutting off all operator alert systems simultaneously.

NOTE For electromagnetic compatibility, see ISO 14982.

4.8 Hydraulic components and fittings

4.8.1 Hydraulic systems shall comply with the safety requirements of ISO 4413.

4.8.2 Flexible hydraulic hose assemblies in the vicinity of the operator's or instructional seats shall be arranged or protected such that they do not present a hazard to the operator in the event of failure.

4.9 Ballast weights

Ballast weights shall bear the manufacturer's mark and a statement of their mass in kilograms to an accuracy of $\pm 5\%$.

4.10 Levelling adjustments — Rear and front linkages

Adequate hand clearance of 25 mm minimum shall be provided for any manually operated levelling adjustment mechanism(s) on the lift rod(s), throughout the total range of travel of the linkage.

4.11 Fuel systems

4.11.1 The fuel tank shall be corrosion-resistant and shall satisfy leakage test at a pressure equal to double the working pressure or 30 kPa, whichever is greater.

4.11.2 The fuel tank filler orifice shall be located outside the operator's cab and not more than 1 500 mm above the ground or a platform.

4.11.3 The fuel tank shall be equipped with automatic pressure limiting means (vent, safety valve or other means) to prevent pressure greater than the working pressure. Fuel shall not escape, other than by dripping, through the fuel tank cap or the pressure limiting means even if the tank is completely overturned.

4.11.4 There shall be no protruding parts, sharp edges or objects near the tank that could create a risk of damage to the fuel tank.

4.11.5 Fuel sediment bowl assemblies, if used, shall be fire-resistant.

4.12 Roll-over protection

4.12.1 A roll-over protection system meeting the requirements of either ISO 5700 or ISO 3463 shall be installed.

4.12.2 Batteries, oil reservoirs and coolant systems shall be located, constructed, coated and/or sealed to minimize the risk of spillage that might be injurious to the operator in the event of an overturn.

4.13 Falling objects protection

An appropriate overhead protective structure should be made available for tractors intended to operate in environments where the hazard of falling objects exists (e.g. forestry applications). The operator's manual shall contain appropriate information explaining when an overhead protective structure is to be used and warning the operator not to operate the tractor in applications where the hazard of falling objects is reasonably foreseeable without such a structure.

NOTE Test method and acceptance criteria are under development.

4.14 Hot surfaces

Hot surfaces which can be reached unintentionally by the operator during normal operation of the tractor shall be covered or insulated. This applies to hot surfaces which are near steps, to handrails, handholds and integral machine parts used as boarding means and which may be inadvertently touched.

NOTE ISO 13732-1 can be used as guidance for the determination of hot surfaces.

4.15 Exhaust gases

The engine exhaust system shall release the exhaust gas away from the operator and the air inlet of the cabin.

4.16 Steering

For steering, the requirements of ISO 10998 apply.

4.17 Storage of operator's manual

An easily accessible dry storage place for the operator's manual shall be provided on the tractor.

5 Information for use

5.1 Operator's manual

5.1.1 An operator's manual, in an official language of the country of sale, shall be supplied with each tractor.

5.1.2 The operator's manual shall provide safety instructions for normal operation and servicing of the machine, including the use of personal protective equipment as appropriate, and shall meet the requirements of ISO 3600.

5.1.3 In particular, the following information and points shall be included, as relevant:

- a) adjustment of the seat and suspension (including the use of the seat belt) related to the ergonomic position of the operator with respect to the controls;
- b) use and adjustment of the heating, ventilation, and air-conditioning system;
- c) starting and stopping of the engine, including a warning not to start the tractor from any position except as specified by the manufacturer;

- d) location and method of opening the emergency exits;
- e) boarding and leaving the tractor, including actuating the parking brake before leaving the operator's station;
- f) hazards related to the pivot area of articulated tractors;
- g) use of special tools;
- h) safe methods for service and maintenance;
- i) inspection of hydraulic hoses;
- j) towing the tractor;
- k) safe use of jacks and recommended jacking points;
- l) hazards related to batteries and the fuel tank(s);
- m) overturning hazards (near soft verges of waterways, on steep slopes, etc.) with mention that the list is not exhaustive;
- n) attaching, detaching and working with mounted, semi-mounted and trailed machinery and trailers (interchangeable towed machinery);
- o) emphasis of the importance of following the instructions outlined in the operator's manual for mounted, semi-mounted or trailed machinery or trailers;
- p) staying clear of the three-point linkage when controlling it;
- q) lowering mounted and semi-mounted machinery to the ground before leaving the tractor;
- r) hydraulic coupling devices and their function and use;
- s) capacity of the three-point linkage;
- t) maximum permissible total weight, axle loads and tyre loads and ballasting requirements;
- u) trailer braking systems and their compatibility with trailed machinery (connecting lines — hydraulic, electric, pneumatic);
- v) the maximum vertical load on the rear hitch, related to the rear tyre size and type of hitch;
- w) the maximum allowed trailed mass;
- x) hazards associated with the area between the tractor and mounted, semi-mounted or trailed machinery;
- y) noise emission values, if required to be declared;
- z) description and function of controls including an explanation of the symbols used.

5.2 Safety and instructional signs

5.2.1 Safety signs shall be appropriately displayed whenever necessary to alert the operator and others of the risk of personal injury during normal operation and servicing.

5.2.2 Safety signs shall conform to the requirements of ISO 11684.

5.2.3 Instructional signs relating to equipment operation, servicing and care shall have an appearance, especially colour, different from safety signs on the equipment.

Bibliography

- [1] ISO 5353:1995, *Earth-moving machinery, and tractors and machinery for agriculture and forestry — Seat index point*
- [2] ISO 13732-1, *Ergonomics of the thermal environment — Methods for the assessment of human responses to contact with surfaces — Part 1: Hot surfaces*
- [3] ISO 14982, *Agricultural and forestry machinery — Electromagnetic compatibility — Test methods and acceptance criteria*
- [4] ISO 26322-2, *Tractors for agriculture and forestry — Safety — Part 2: Narrow track and small tractors*

ICS 65.060.10

Price based on 12 pages

BSI - British Standards Institution

BSI is the independent national body responsible for preparing British Standards. It presents the UK view on standards in Europe and at the international level. It is incorporated by Royal Charter.

Revisions

British Standards are updated by amendment or revision. Users of British Standards should make sure that they possess the latest amendments or editions.

It is the constant aim of BSI to improve the quality of our products and services. We would be grateful if anyone finding an inaccuracy or ambiguity while using this British Standard would inform the Secretary of the technical committee responsible, the identity of which can be found on the inside front cover. Tel: +44 (0)20 8996 9000. Fax: +44 (0)20 8996 7400.

BSI offers members an individual updating service called PLUS which ensures that subscribers automatically receive the latest editions of standards.

Buying standards

Orders for all BSI, international and foreign standards publications should be addressed to Customer Services. Tel: +44 (0)20 8996 9001. Fax: +44 (0)20 8996 7001 Email: orders@bsigroup.com You may also buy directly using a debit/credit card from the BSI Shop on the Website <http://www.bsigroup.com/shop>

In response to orders for international standards, it is BSI policy to supply the BSI implementation of those that have been published as British Standards, unless otherwise requested.

Information on standards

BSI provides a wide range of information on national, European and international standards through its Library and its Technical Help to Exporters Service. Various BSI electronic information services are also available which give details on all its products and services. Contact Information Centre. Tel: +44 (0)20 8996 7111 Fax: +44 (0)20 8996 7048 Email: info@bsigroup.com

Subscribing members of BSI are kept up to date with standards developments and receive substantial discounts on the purchase price of standards. For details of these and other benefits contact Membership Administration. Tel: +44 (0)20 8996 7002 Fax: +44 (0)20 8996 7001 Email: membership@bsigroup.com

Information regarding online access to British Standards via British Standards Online can be found at <http://www.bsigroup.com/BSOL>

Further information about BSI is available on the BSI website at <http://www.bsigroup.com>

Copyright

Copyright subsists in all BSI publications. BSI also holds the copyright, in the UK, of the publications of the international standardization bodies. Except as permitted under the Copyright, Designs and Patents Act 1988 no extract may be reproduced, stored in a retrieval system or transmitted in any form or by any means – electronic, photocopying, recording or otherwise – without prior written permission from BSI.

This does not preclude the free use, in the course of implementing the standard, of necessary details such as symbols, and size, type or grade designations. If these details are to be used for any other purpose than implementation then the prior written permission of BSI must be obtained.

Details and advice can be obtained from the Copyright and Licensing Manager. Tel: +44 (0)20 8996 7070 Email: copyright@bsigroup.com