

BS ISO 26146:2012



BSI Standards Publication

Corrosion of metals and alloys — Method for metallographic examination of samples after exposure to high-temperature corrosive environments

bsi.

...making excellence a habit.™

National foreword

This British Standard is the UK implementation of ISO 26146:2012.

The UK participation in its preparation was entrusted to Technical Committee ISE/NFE/8, Corrosion of metals and alloys.

A list of organizations represented on this committee can be obtained on request to its secretary.

This publication does not purport to include all the necessary provisions of a contract. Users are responsible for its correct application.

© The British Standards Institution 2012. Published by BSI Standards Limited 2012

ISBN 978 0 580 69313 7

ICS 77.060

Compliance with a British Standard cannot confer immunity from legal obligations.

This British Standard was published under the authority of the Standards Policy and Strategy Committee on 31 December 2012.

Amendments issued since publication

| Date | Text affected |
|------|---------------|
|------|---------------|

INTERNATIONAL
STANDARD

ISO
26146

First edition
2012-12-15

**Corrosion of metals and alloys —
Method for metallographic examination
of samples after exposure to high-
temperature corrosive environments**

*Corrosion des métaux et alliages — Méthode d'étude
métallographique d'échantillons soumis à des environnements
corrosifs à haute température*



Reference number
ISO 26146:2012(E)

© ISO 2012



COPYRIGHT PROTECTED DOCUMENT

© ISO 2012

All rights reserved. Unless otherwise specified, no part of this publication may be reproduced or utilized in any form or by any means, electronic or mechanical, including photocopying and microfilm, without permission in writing from either ISO at the address below or ISO's member body in the country of the requester.

ISO copyright office
Case postale 56 • CH-1211 Geneva 20
Tel. + 41 22 749 01 11
Fax + 41 22 749 09 47
E-mail copyright@iso.org
Web www.iso.org

Published in Switzerland

Contents

Page

| | |
|---|-----------|
| Foreword | iv |
| 1 Scope | 1 |
| 2 Normative references | 1 |
| 3 Terms and definitions | 1 |
| 4 Symbols and abbreviated terms | 3 |
| 4.1 Symbols..... | 3 |
| 4.2 Abbreviated terms used as subscripts..... | 3 |
| 5 Requirements | 4 |
| 6 Test method | 4 |
| 6.1 Test pieces..... | 4 |
| 6.2 Procedure..... | 5 |
| 6.3 Complementary techniques..... | 10 |
| 6.4 Test report..... | 10 |
| Bibliography | 12 |

Foreword

ISO (the International Organization for Standardization) is a worldwide federation of national standards bodies (ISO member bodies). The work of preparing International Standards is normally carried out through ISO technical committees. Each member body interested in a subject for which a technical committee has been established has the right to be represented on that committee. International organizations, governmental and non-governmental, in liaison with ISO, also take part in the work. ISO collaborates closely with the International Electrotechnical Commission (IEC) on all matters of electrotechnical standardization.

International Standards are drafted in accordance with the rules given in the ISO/IEC Directives, Part 2.

The main task of technical committees is to prepare International Standards. Draft International Standards adopted by the technical committees are circulated to the member bodies for voting. Publication as an International Standard requires approval by at least 75 % of the member bodies casting a vote.

ISO 26146 was prepared by Technical Committee ISO/TC 156, *Corrosion of metals and alloys*.

Corrosion of metals and alloys — Method for metallographic examination of samples after exposure to high-temperature corrosive environments

1 Scope

This International Standard covers examination of samples that have previously been exposed to corrosive environments at high temperatures.

This International Standard covers the classification, identification, and thickness measurement of any corrosion layer forming during the exposure.

2 Normative references

The following documents, in whole or in part, are normatively referenced in this document and are indispensable for its application. For dated references, only the edition cited applies. For undated references, the latest edition of the referenced document (including any amendments) applies.

ISO 3611, *Geometrical product specifications (GPS) — Dimensional measuring equipment: Micrometers for external measurements — Design and metrological characteristics*

ISO 13385-1, *Geometrical product specifications (GPS) — Dimensional measuring equipment — Part 1: Callipers; Design and metrological characteristics*

3 Terms and definitions

For the purposes of this document, the following terms and definitions apply.

NOTE [Figure 1](#) provides a diagrammatic representation of appropriate parameters.

3.1

original metal surface

surface of the metallic sample before coating or exposure to the corrosive environment

3.2

original coating surface

surface of the coating after final processing treatment but before exposure to the corrosive environment

3.3

interdiffusion zone

region around the original interface between coating and substrate that, during exposure, has changed composition through diffusion processes between the coating and the substrate

3.4

deposit

chemically active liquid or solid species that are placed in contact with or are deposited on the test piece before and/or during exposure

EXAMPLE Salts, fly ashes, chars, and molten metals.

3.5

deposit thickness

distance, normal to the test piece surface, between the outer extent of corrosion product and the surface of the deposit layer

3.6
coating
layer of material applied to a metal surface to provide protection

3.7
coating thickness
distance, normal to the test piece surface, between the original metal surface and the surface of the coating

3.8
outward growing corrosion scale
corrosion scale that grows outwards from the original metal or coating surface

3.9
inward growing corrosion scale
corrosion scale that grows inwards from the original metal or coating surface

3.10
external scale
total of outward and inward growing continuous corrosion scales

3.11
internal corrosion
corrosion products that form beneath any external scale

Note 1 to entry: These usually appear as discrete particles.

3.12
grain boundary corrosion
corrosion product that grows along metal grain boundaries as a particular form of internal corrosion

3.13
de-alloyed zone
zone beneath the corrosion scale(s) that exhibits a decrease in the concentration of scale-forming alloy elements

Note 1 to entry: This may be manifested as the dissolution of precipitates originally present in the microstructure.

3.14
metal loss
distance between the original test piece surface and the boundary with unaffected alloy

3.15
remaining sound metal
section of metal that has not been affected by corrosion

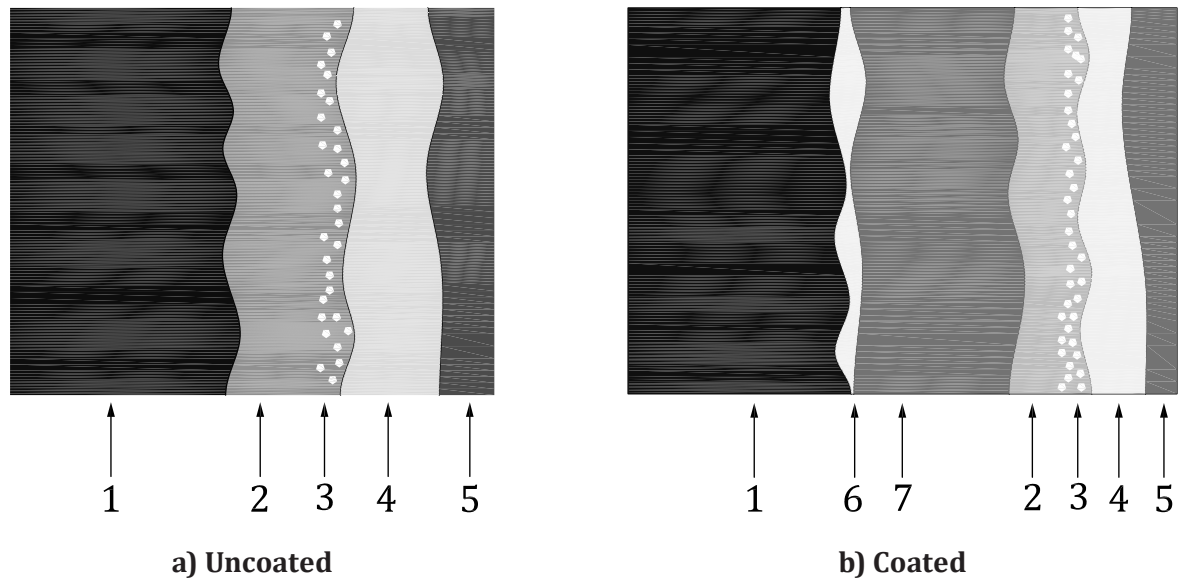

Key

- 1 substrate
- 2 de-alloyed zone
- 3 internal corrosion
- 4 external scale
- 5 deposit
- 6 interdiffusion zone
- 7 coating

Figure 1 — Identification of individual layers to be measured in exposed test pieces

4 Symbols and abbreviated terms

4.1 Symbols

- x thickness of individual layer
- t metal thickness

4.2 Abbreviated terms used as subscripts

The identification of individual layers is through the use of the following subscripts:

| | |
|-----|--|
| 0 | initial |
| og | outward growing part of the external corrosion scale |
| ig | inward growing part of the external corrosion scale |
| tot | total thickness of external scale ($x_{\text{tot}} = x_{\text{og}} + x_{\text{ig}}$) |
| in | internal corrosion |
| gb | grain boundary corrosion |
| d | deposit |
| c | coating |
| da | de-alloyed |
| ml | metal loss compared to original dimensions |
| rm | remaining sound metal |

5 Requirements

The minimum requirement for measurement accuracy is to achieve an uncertainty at the 95 % confidence limit of $\pm 5 \mu\text{m}$ or 5 % of the measured material loss, whichever is the lesser for all errors, i.e. calibration, misalignment, both in the vertical and horizontal directions, and measurement.

Measurements shall be carried out under an optical microscope with an X-Y moving stage or with graticule and cross wires. The precision of the measurement system shall be to a precision of $\pm 1 \mu\text{m}$.

The measurement system shall be fully calibrated to include orthogonality, traceable to certified length standards at intervals no greater than 12 months. The system shall be checked against secondary standards at the beginning and the end of each series of measurements.

6 Test method

6.1 Test pieces

The size(s) and shape(s) of the test pieces adopted are governed by the type and form of material received from the various suppliers, e.g. wrought products (bar, rod, plate, strip) or cast products (sticks of varying shapes).

Three basic forms of test piece are considered appropriate, i.e. rod, disc, or block. These simple geometries are easier to measure and hence less prone to errors.

Machine tolerances should preferably be better than $\pm 0,05 \text{ mm}$; however, on larger test pieces, this requirement may be relaxed.

Reference marks are not usually made on test pieces exposed in the laboratory. However, for special cases or other exposures, e.g. probes in plant, test pieces may contain reference positions sufficient to identify a specific point within the measurement plane, both pre- and post-exposure. The reference marks serve as a datum, thus ensuring that repeat measurements are made at identical positions on the test piece. This can be achieved by use of a reference mark and reference groove. These reference marks and grooves vary with test piece geometry. [Figure 2](#) shows the reference mark and groove for a block sample; similar marks and grooves may be placed on other sample geometries.

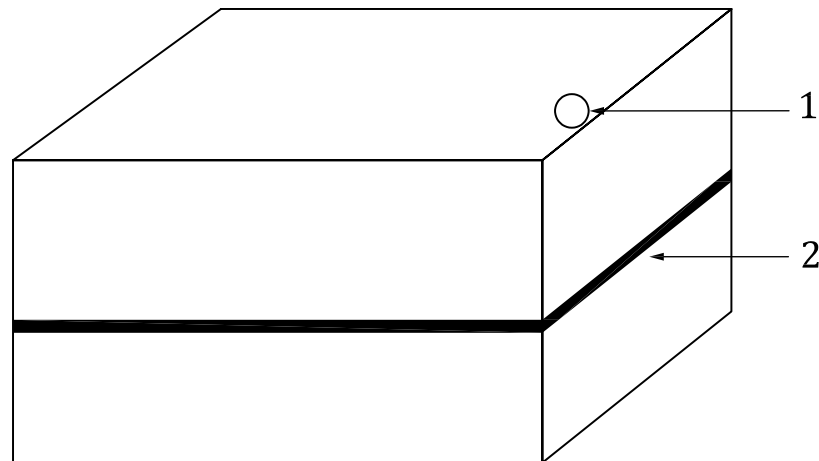

Key

- 1 reference mark
- 2 reference groove

Figure 2 — Example of reference mark on block sample

6.2 Procedure

6.2.1 Examination prior to exposure

The dimensions of the uncorroded sample shall be measured prior to exposure. The dimensions of the test piece shall be measured with a precision of $\pm 0,02$ mm by means of the measuring instruments specified in ISO 3611 and ISO 13385-1. Measurements should be taken at a minimum of eight equidistant positions across the intended section for the post-test measurements.

This forms the basis of the definition of the original metal surface.

6.2.2 Preparation of cross-sections

Dimensional changes of the test piece after exposure shall be determined by preparing a metallographic cross-section. Particular care should be taken in preparation of this cross-section to ensure that the test piece is mounted and polished parallel to the intended plane of the cross-section and all corrosion products and deposits are retained. The procedure recommended is as follows.

In order to retain the corrosion product and deposit, the test piece shall be protected with an appropriate coating. A deposited metallic coating or thermoplastic resin may be suitable depending on the system to be investigated.

Specimen supports may be included in the mount to ensure that the section surface remains planar. The artefacts described below may fulfil this purpose.

The test piece may be sectioned before or after mounting. Rod and tube test pieces should be sectioned to a circular cross-section normal to the primary axis. Disc test pieces should be cut parallel to the primary axis. Block test pieces should be cut parallel to the longest side. Sectioning details are shown in [Figure 3](#).

If there is a requirement to reveal a cross-section at a specific plane relative to the surface by a reference mark, the cut should be made at a sufficient distance from that plane to allow for removal of material during grinding and polishing (see [Figure 3](#)).

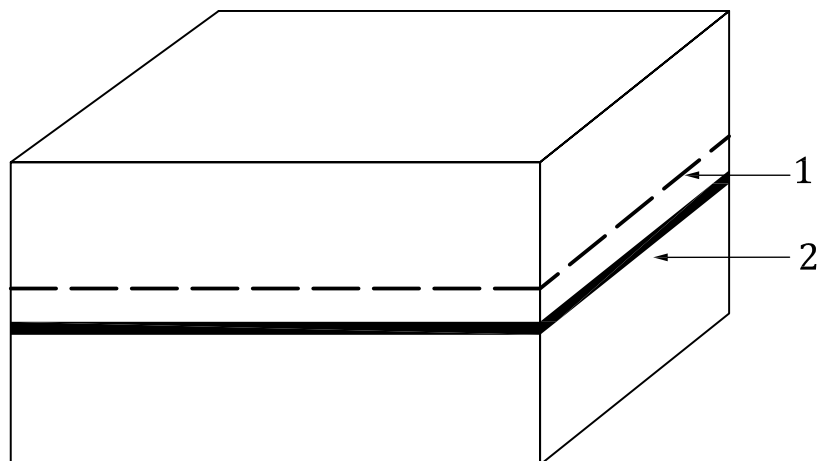

Key

- 1 sectioning cutting
- 2 reference groove

Figure 3 — Sectioning procedure for test pieces with reference mark

In order to verify that the test piece has been mounted and polished parallel to the intended plane of the cross-section, one or more reference artefacts of known dimensions should be included in the mount. Flat test pieces (disc and square geometries) may be mounted together with a metal sheet of constant and known thickness ($\pm 1 \mu\text{m}$) clamped parallel to the test piece. Rod-shaped test pieces may use a similar metal sheet of known thickness that has been bent through a known angle (90° is convenient) and the test piece held in the corner. Alternatively, a series of spheres may be positioned around the test piece in the mount. An illustration of the use of comparison artefacts to check the alignment of polishing is shown in [Figure 4](#).

A mounting material with a low shrinkage should be selected and the test piece securely held vertical to the surface of the mount. Vacuum impregnation with cold setting resin may be used for mounting porous scale material.

Grinding and polishing procedures vary according to the test piece, but special care should be taken to use appropriate lubricants in order not to dissolve components of the corrosion product or deposit. (For example, alkali sulphates or halides dissolve in water so non-aqueous lubricants shall be used.)

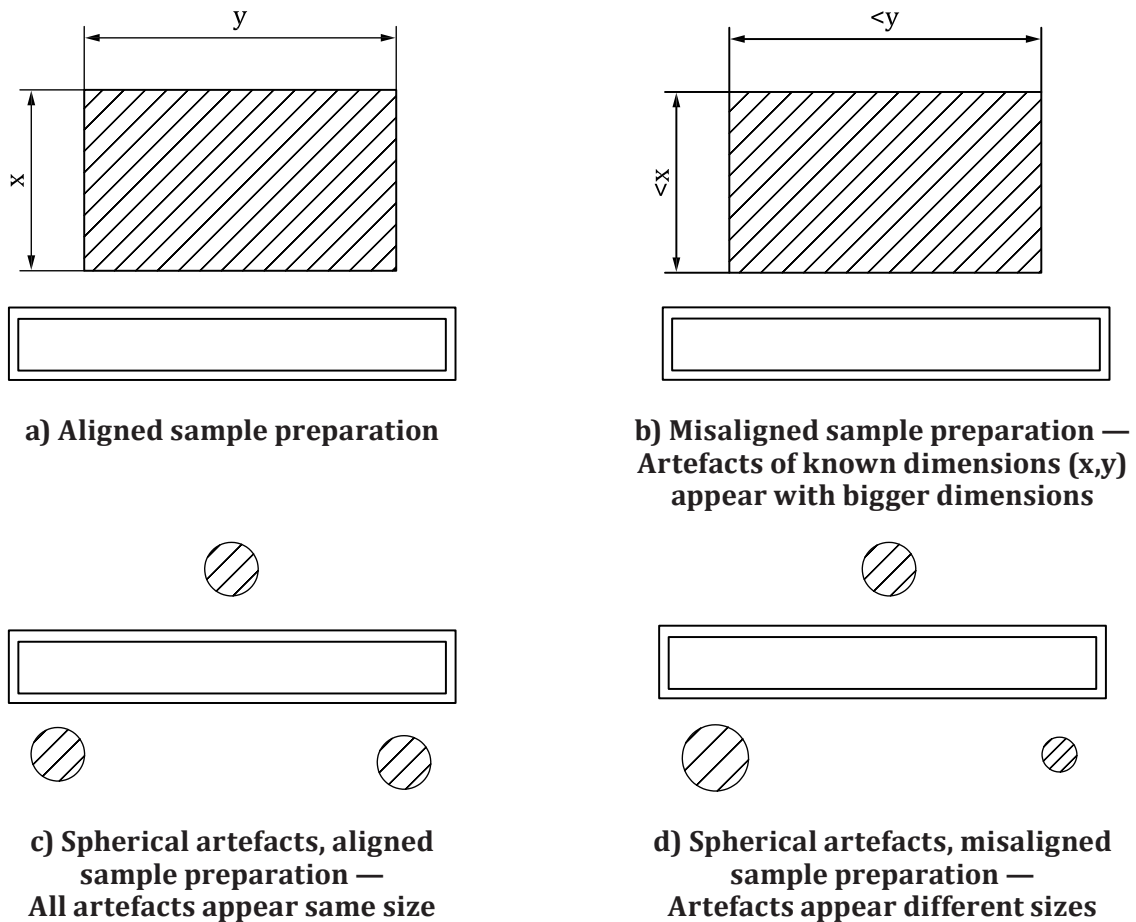

Figure 4 — Use of reference artefacts to determine alignment during polishing

6.2.3 Classification of corrosion layers

The following layers may be present in an exposed sample:

- surface deposit;
- outward growing corrosion scale;
- inward growing corrosion scale;
- internal corrosion;
- grain boundary attack;
- de-alloyed zone;
- remaining coating;
- interdiffusion zone;
- unaffected alloy (remaining sound metal).

The definitions of these layers are given in [Clause 3](#).

6.2.4 Identification of corrosion layers

Optical micrographs of the corrosion product and deposit should be taken at, preferably, a set of standard magnifications, e.g. x100, x400, and x1 000, but these vary depending upon the extent of attack. It is imperative that the chosen magnifications clearly show the extent of the total attack in a single micrograph so that the entire external corrosion product layer thickness is seen. A micron bar should be included in the micrograph.

Contrast between the different layers may be enhanced by various techniques, e.g. chemical etching or interference films.

Additional characterization by SEM, XRD, etc., is optional and depends on the particular requirements of the investigation.

6.2.5 Thickness measurement of corrosion layers for metal loss evaluation

The test piece shall be divided into eight sectors of approximately equal size.

Each sector shall be examined at low magnification in order to locate the area with the smallest remaining metal thickness. These are the areas at which the measurements are to be made.

The selected areas are examined at high magnification such that a 100 μm length of surface is viewed in a single field.

The positions c and d, shown and defined in [Figure 5](#), shall be measured. In addition, positions a, f, b, and e may be measured to provide supplementary information on the extent of the different corrosion layers.

The minimum remaining metal thickness, t_{rm} , is the distance between c and d and shall be reported together with the metal loss $t_{\text{ml}} = (t_0 - t_{\text{rm}})/2$.

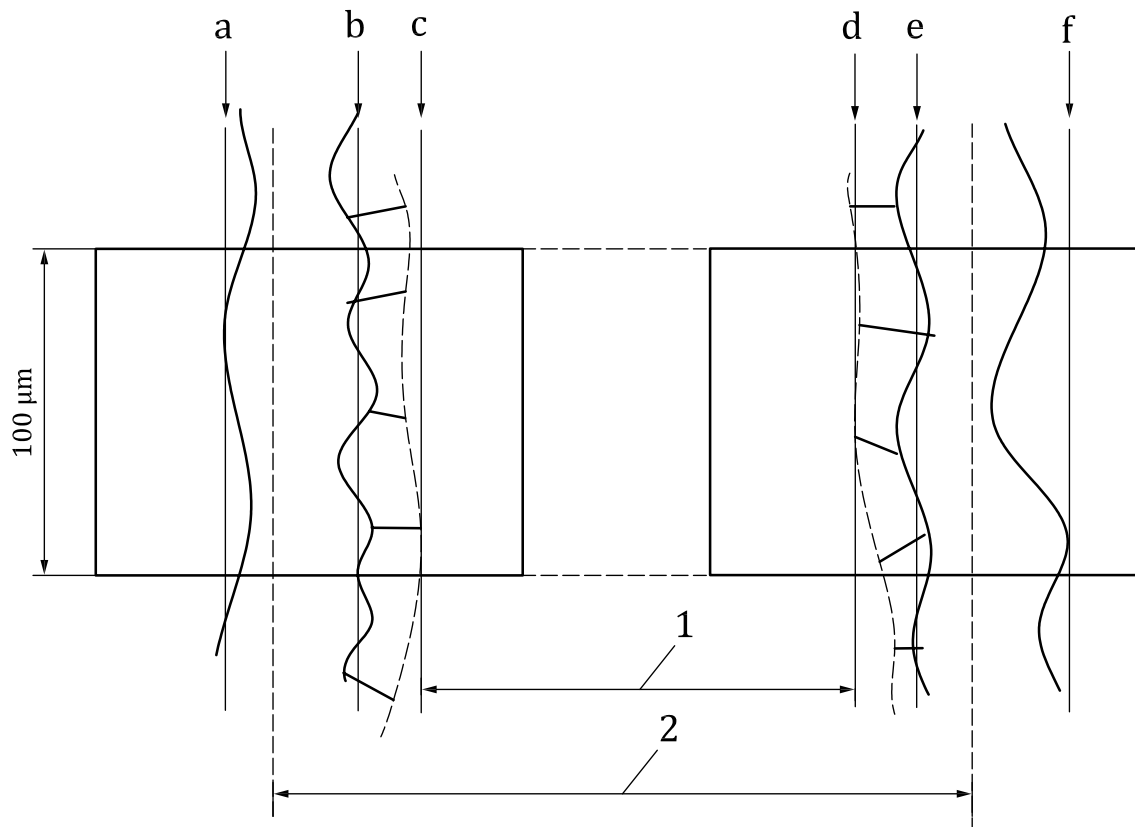

Key

- 1 t_{rm}
- 2 initial specimen thickness = t_0
- a, f outermost positions of the corrosion scale within the field of view and positions
- b, e positions of the scale/metal interface, defined as the lines for which there were equal amounts of metal on the corroded side as corrosion product on the metal side
- c, d deepest positions of grain boundary penetration or internal corrosion products, whichever is relevant, within the field of view

Figure 5 — Method for measurement of corrosion layers

6.2.6 Thickness measurement of corrosion layers for full statistical analysis

Flat corroded test pieces shall be measured at regular intervals along the length, and rod-shaped test pieces shall be measured at regular angular intervals around the circumference; in both cases, a minimum of 24 measurements shall be obtained.

Corrosive attack may be measured either as the thickness of individual layers, the total thickness of the affected region, or the total metal loss. The value to be reported shall be agreed between interested parties prior to commencement of the work.

For each measure of corrosion, the following shall be reported:

- the mean value of the measurements;
- the standard deviation of the measurements.

The full data set, plotted on “probability” axes, provides valuable information on the superposition of multiple corrosion mechanisms. Data are sorted in descending order and the individual thickness/metal loss is plotted against probability. Data fitting a Gaussian distribution appear as a straight line whose slope is related to the standard deviation of the data set. Any deviation from a straight line is interpreted as the

appearance of a second distribution in the measurement, e.g. due to pitting or grain boundary attack. It is recommended that plots of this type are used; examples of the use of this plot are given in [Figure 6](#).

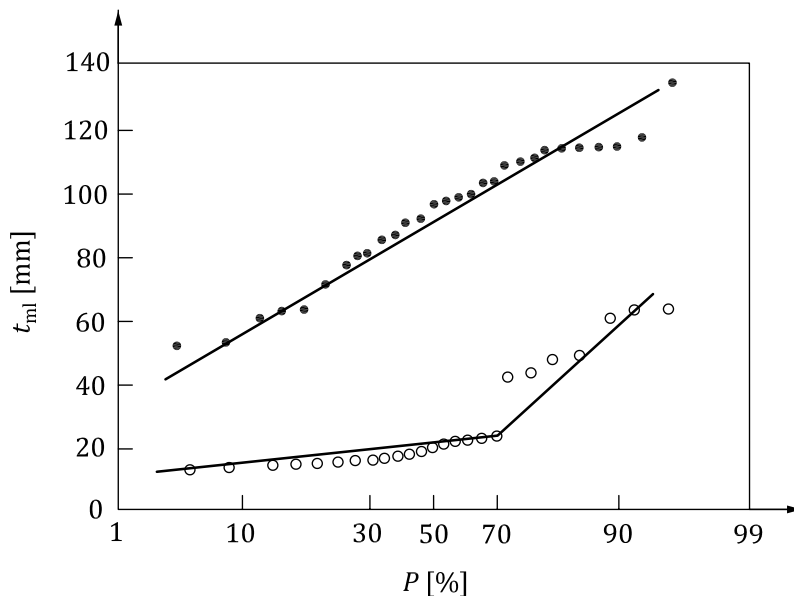

Key

- P probability of metal loss not exceeding value
- t_{ml} thickness of metal loss
- single distribution
- duplex distribution

Figure 6 — Example of probability plot for measurement of corrosion

The most probable extreme metal loss (or corrosion product thickness) shall be reported, as component failure is invariably associated with the rate of growth of such extreme features. The “most probable extreme” value is the maximum value measured for each feature. For the recommended methods of measurement, there is a 4 % chance that the true extreme metal loss exceeds this value.

6.3 Complementary techniques

Local composition of phases may be measured using energy-dispersive X-ray (EDX) or wavelength-dispersive X-ray (WDX) facilities.

Phase identification using crystallographic measurements may be carried out using X-ray diffraction (XRD).

Measurement of alloy depletion profiles may be made using Electron Probe Micro Analysis (EPMA, WDX).

6.4 Test report

The test report shall contain (at least) the following data:

- a) details of the exposure experiment, i.e. material, atmosphere, temperature, duration;
- b) test piece shape and dimension;
- c) identification of all layers identified after exposure;
- d) measurements according to the procedure used;
- e) a micrograph of a cross-section of a representative region of the test piece.

The test report should also include identification of the corrosion products present through use of EDX, WDX, or XRD, if available.

Bibliography

- [1] ISO 13573, *Corrosion of metals and alloys — Test method for thermal-cycling exposure testing under high-temperature corrosion conditions for metallic materials*
- [2] ISO 21608:2012, *Corrosion of metals and alloys — Test method for isothermal-exposure oxidation testing under high-temperature corrosion conditions for metallic materials*

British Standards Institution (BSI)

BSI is the national body responsible for preparing British Standards and other standards-related publications, information and services.

BSI is incorporated by Royal Charter. British Standards and other standardization products are published by BSI Standards Limited.

About us

We bring together business, industry, government, consumers, innovators and others to shape their combined experience and expertise into standards-based solutions.

The knowledge embodied in our standards has been carefully assembled in a dependable format and refined through our open consultation process. Organizations of all sizes and across all sectors choose standards to help them achieve their goals.

Information on standards

We can provide you with the knowledge that your organization needs to succeed. Find out more about British Standards by visiting our website at bsigroup.com/standards or contacting our Customer Services team or Knowledge Centre.

Buying standards

You can buy and download PDF versions of BSI publications, including British and adopted European and international standards, through our website at bsigroup.com/shop, where hard copies can also be purchased.

If you need international and foreign standards from other Standards Development Organizations, hard copies can be ordered from our Customer Services team.

Subscriptions

Our range of subscription services are designed to make using standards easier for you. For further information on our subscription products go to bsigroup.com/subscriptions.

With **British Standards Online (BSOL)** you'll have instant access to over 55,000 British and adopted European and international standards from your desktop. It's available 24/7 and is refreshed daily so you'll always be up to date.

You can keep in touch with standards developments and receive substantial discounts on the purchase price of standards, both in single copy and subscription format, by becoming a **BSI Subscribing Member**.

PLUS is an updating service exclusive to BSI Subscribing Members. You will automatically receive the latest hard copy of your standards when they're revised or replaced.

To find out more about becoming a BSI Subscribing Member and the benefits of membership, please visit bsigroup.com/shop.

With a **Multi-User Network Licence (MUNL)** you are able to host standards publications on your intranet. Licences can cover as few or as many users as you wish. With updates supplied as soon as they're available, you can be sure your documentation is current. For further information, email bsmusales@bsigroup.com.

BSI Group Headquarters

389 Chiswick High Road London W4 4AL UK

Revisions

Our British Standards and other publications are updated by amendment or revision.

We continually improve the quality of our products and services to benefit your business. If you find an inaccuracy or ambiguity within a British Standard or other BSI publication please inform the Knowledge Centre.

Copyright

All the data, software and documentation set out in all British Standards and other BSI publications are the property of and copyrighted by BSI, or some person or entity that owns copyright in the information used (such as the international standardization bodies) and has formally licensed such information to BSI for commercial publication and use. Except as permitted under the Copyright, Designs and Patents Act 1988 no extract may be reproduced, stored in a retrieval system or transmitted in any form or by any means – electronic, photocopying, recording or otherwise – without prior written permission from BSI. Details and advice can be obtained from the Copyright & Licensing Department.

Useful Contacts:

Customer Services

Tel: +44 845 086 9001

Email (orders): orders@bsigroup.com

Email (enquiries): cservices@bsigroup.com

Subscriptions

Tel: +44 845 086 9001

Email: subscriptions@bsigroup.com

Knowledge Centre

Tel: +44 20 8996 7004

Email: knowledgecentre@bsigroup.com

Copyright & Licensing

Tel: +44 20 8996 7070

Email: copyright@bsigroup.com



...making excellence a habit.™