

# Hydrogen detection apparatus — Stationary applications

ICS 71.020; 71.100.20

## National foreword

This British Standard is the UK implementation of ISO 26142:2010.

The UK participation in its preparation was entrusted to Technical Committee PVE/3/8, Gas containers - Hydrogen technologies.

A list of organizations represented on this committee can be obtained on request to its secretary.

This publication does not purport to include all the necessary provisions of a contract. Users are responsible for its correct application.

**Compliance with a British Standard cannot confer immunity from legal obligations.**

This British Standard was published under the authority of the Standards Policy and Strategy Committee on 30 June 2010

© BSI 2010

ISBN 978 0 580 64572 3

### Amendments/corrigenda issued since publication

Date	Comments

INTERNATIONAL  
STANDARD

BS ISO 26142:2010

**ISO**  
**26142**

First edition  
2010-06-01

---

---

**Hydrogen detection apparatus —  
Stationary applications**

*Détecteurs d'hydrogène — Applications fixes*



Reference number  
ISO 26142:2010(E)

© ISO 2010

**PDF disclaimer**

This PDF file may contain embedded typefaces. In accordance with Adobe's licensing policy, this file may be printed or viewed but shall not be edited unless the typefaces which are embedded are licensed to and installed on the computer performing the editing. In downloading this file, parties accept therein the responsibility of not infringing Adobe's licensing policy. The ISO Central Secretariat accepts no liability in this area.

Adobe is a trademark of Adobe Systems Incorporated.

Details of the software products used to create this PDF file can be found in the General Info relative to the file; the PDF-creation parameters were optimized for printing. Every care has been taken to ensure that the file is suitable for use by ISO member bodies. In the unlikely event that a problem relating to it is found, please inform the Central Secretariat at the address given below.



**COPYRIGHT PROTECTED DOCUMENT**

© ISO 2010

All rights reserved. Unless otherwise specified, no part of this publication may be reproduced or utilized in any form or by any means, electronic or mechanical, including photocopying and microfilm, without permission in writing from either ISO at the address below or ISO's member body in the country of the requester.

ISO copyright office  
Case postale 56 • CH-1211 Geneva 20  
Tel. + 41 22 749 01 11  
Fax + 41 22 749 09 47  
E-mail [copyright@iso.org](mailto:copyright@iso.org)  
Web [www.iso.org](http://www.iso.org)

Published in Switzerland

# Contents

Page

Foreword .....	v
Introduction.....	vi
<b>1 Scope .....</b>	<b>1</b>
<b>2 Normative references .....</b>	<b>1</b>
<b>3 Terms and definitions .....</b>	<b>1</b>
<b>4 General requirements .....</b>	<b>4</b>
4.1 Construction .....	4
4.1.1 General .....	4
4.1.2 Enclosure .....	4
4.1.3 Measuring range .....	4
4.1.4 Alarm system .....	4
4.1.5 Indicators.....	5
4.1.6 Adjustments .....	5
4.1.7 Software-controlled hydrogen detection apparatus .....	6
4.1.8 Reliability.....	7
4.2 Labelling and marking .....	8
4.3 Instruction manual .....	8
4.4 Vibration .....	9
<b>5 Performance requirements.....</b>	<b>9</b>
<b>6 Tests .....</b>	<b>9</b>
6.1 General requirements for tests .....	9
6.1.1 Number of samples .....	9
6.1.2 Sequence of tests.....	9
6.1.3 Preparation of the hydrogen detection apparatus before testing.....	10
6.2 Test equipment .....	10
6.3 Normal test conditions.....	10
6.3.1 Temperature .....	10
6.3.2 Pressure .....	10
6.3.3 Humidity .....	10
6.3.4 Voltage.....	10
6.3.5 Orientation .....	10
6.4 Test methods .....	11
6.4.1 General .....	11
6.4.2 Standard response test.....	11
6.4.3 Measuring range and calibration .....	11
6.4.4 Stability.....	12
6.4.5 Alarm set point(s) .....	13
6.4.6 Temperature .....	13
6.4.7 Pressure .....	14
6.4.8 Humidity .....	14
6.4.9 Vibration .....	14
6.4.10 Orientation .....	15
6.4.11 Flow rate for aspirated apparatus.....	16
6.4.12 Air velocity .....	16
6.4.13 Time of response and time of recovery .....	17
6.4.14 Selectivity .....	17
6.4.15 Poisoning .....	17
6.4.16 Operation above the measuring range.....	18
6.4.17 Power supply variations .....	18

<b>6.4.18</b>	<b>Power supply interruptions, voltage transients and step changes of voltage .....</b>	<b>19</b>
<b>6.4.19</b>	<b>Warm-up time after restart .....</b>	<b>19</b>
<b>6.4.20</b>	<b>Electromagnetic immunity .....</b>	<b>19</b>
<b>6.4.21</b>	<b>Field calibration kit .....</b>	<b>20</b>
<b>Annex A</b>	<b>(informative) Chamber test method .....</b>	<b>21</b>
<b>Annex B</b>	<b>(informative) Flow-through test method.....</b>	<b>24</b>
<b>Bibliography</b>	<b>.....</b>	<b>27</b>

## Foreword

ISO (the International Organization for Standardization) is a worldwide federation of national standards bodies (ISO member bodies). The work of preparing International Standards is normally carried out through ISO technical committees. Each member body interested in a subject for which a technical committee has been established has the right to be represented on that committee. International organizations, governmental and non-governmental, in liaison with ISO, also take part in the work. ISO collaborates closely with the International Electrotechnical Commission (IEC) on all matters of electrotechnical standardization.

International Standards are drafted in accordance with the rules given in the ISO/IEC Directives, Part 2.

The main task of technical committees is to prepare International Standards. Draft International Standards adopted by the technical committees are circulated to the member bodies for voting. Publication as an International Standard requires approval by at least 75 % of the member bodies casting a vote.

Attention is drawn to the possibility that some of the elements of this document may be the subject of patent rights. ISO shall not be held responsible for identifying any or all such patent rights.

ISO 26142 was prepared by Technical Committee ISO/TC 197, *Hydrogen technologies*.

## Introduction

Over the course of several years, international efforts have been initiated for the development of necessary regulations, codes and standards required for the introduction of hydrogen energy systems in consumer environments. Such codes and standards usually require a safety system to detect hydrogen concentrations before a fraction of the flammable or explosive limit is reached, in order to allow for purging, shut-off, and similar safety operations.

This International Standard provides requirements for stationary hydrogen detection apparatus, covering both performance requirements and test methods. This International Standard is intended to cover situations where the user desires the ability to detect hydrogen leaks and monitor hydrogen concentrations relevant to safety. This International Standard is primarily intended for hydrogen detection apparatus at vehicle refuelling stations, where a high level of safety management is required. This sector has an immediate need for this standard and is expected to be the main application for such apparatus, but this standard can also be applied to other stationary installations where the detection of hydrogen is required.

This International Standard is not intended to exclude any specific technologies that meet the performance requirements herein.

This International Standard contains the important quantitative and technical specifications against the danger of hydrogen leakage. This standard will promote international cooperation under easy-to-understand requirements, by leading to widespread use of hydrogen energy.

Benefits to be gained by the implementation of this International Standard include using the performance requirements in the standard to overcome safety concerns and aiding in development of the hydrogen fuel infrastructure.

In this International Standard, attention is concentrated on specific requirements related to performance and testing of hydrogen detection apparatus, such as a specific detection range for single and multiple safety systems, selectivity, poisoning, fast response time, and hydrogen-specific test methods needed by the hydrogen energy industry. This International Standard focuses primarily on stationary hydrogen technologies whose main purpose is to produce, store and handle hydrogen, and not on systems that might generate hydrogen as an undesirable by-product. The purpose of a hydrogen detection apparatus according to this standard is to mitigate risk from unintended hydrogen releases within a wide range of hydrogen concentrations including those exceeding the lower flammability limit.

Hydrogen-related facilities might be required to have the ability to detect hydrogen concentrations before a specified concentration of hydrogen or fraction of flammable limit is reached, in order to allow for single and/or multilevel safety operations, such as nitrogen purging or ventilation and/or system shut-off; or there might be a desire to detect hydrogen concentrations above the lower flammability limit, in order to monitor concentrations following a release. The hydrogen detection apparatus described in this International Standard can detect the hydrogen leak concentration at multiple points determined by users to realize such multilevel safety operations.



# Hydrogen detection apparatus — Stationary applications

## 1 Scope

This International Standard defines the performance requirements and test methods of hydrogen detection apparatus that is designed to measure and monitor hydrogen concentrations in stationary applications. The provisions in this International Standard cover the hydrogen detection apparatus used to achieve the single and/or multilevel safety operations, such as nitrogen purging or ventilation and/or system shut-off corresponding to the hydrogen concentration. The requirements applicable to the overall safety system, as well as the installation requirements of such apparatus, are excluded. This International Standard sets out only the requirements applicable to a product standard for hydrogen detection apparatus, such as precision, response time, stability, measuring range, selectivity and poisoning.

This International Standard is intended to be used for certification purposes.

## 2 Normative references

The following referenced documents are indispensable for the application of this document. For dated references, only the edition cited applies. For undated references, the latest edition of the referenced document (including any amendments) applies.

ISO 14687-1:1999, *Hydrogen fuel — Product specification — Part 1: All applications except proton exchange membrane (PEM) fuel cell for road vehicles*

ISO 14687-1:1999/Cor.2:2008, *Hydrogen fuel — Product specification — Part 1: All applications except proton exchange membrane (PEM) fuel cell for road vehicles — Technical Corrigendum 2*

IEC 61000-4-1, *Electromagnetic compatibility (EMC) — Part 4-1: Testing and measurement techniques — Overview of IEC 61000-4 series*

IEC 61000-4-3, *Electromagnetic compatibility (EMC) — Part 4-3: Testing and measurement techniques — Radiated, radio-frequency, electromagnetic field immunity test*

IEC 61000-4-4, *Electromagnetic compatibility (EMC) — Part 4-4: Testing and measurement techniques — Electrical fast transient/burst immunity test*

IEC 60079-0:2008, *Explosive atmospheres — Part 0: Equipment — General requirements*

IEC 60079 (all parts), *Explosive atmospheres*

## 3 Terms and definitions

For the purposes of this document, the following terms and definitions apply.

### 3.1

#### alarm set point

fixed or adjustable setting of the hydrogen detection apparatus that is intended to select the hydrogen volume fraction at which an indication, an alarm or another output function will automatically be activated

- 3.2**  
**ambient air**  
normal atmosphere surrounding the hydrogen detection apparatus
- 3.3**  
**aspirated hydrogen detection apparatus**  
hydrogen detection apparatus that samples the gas to be detected by introducing it to the hydrogen sensor(s) in a forced manner (e.g. use of a gas sampling pump or induction of a flow through a pressure differential)
- 3.4**  
**clean air**  
air that is free of flammable gases, interfering or contaminating substances, and dust
- 3.5**  
**control unit**  
part of hydrogen detection apparatus that is commonly referred to as the apparatus body and which excludes its remote sensor(s) and connections, if any
- 3.6**  
**data collecting interval**  
time interval between the time when an indication data is collected and the time when the next indication data is corrected
- 3.7**  
**diffusion chamber**  
chamber that can be sealed with controlled conditions of temperature, humidity and test-gas volume fraction, used for performing the test on the hydrogen detection apparatus
- 3.8**  
**fault signal**  
audible, visible or other type of signal different from the alarm signal, providing, directly or indirectly, a warning or an indication that the hydrogen detection apparatus is not working satisfactorily
- 3.9**  
**final indication**  
indication given by the hydrogen detection apparatus after stabilization
- 3.10**  
**hydrogen detection apparatus**  
assembly with an integrated or a remote hydrogen sensor that is intended to detect and measure the hydrogen volume fraction over a declared measuring range
- NOTE 1 The hydrogen detection apparatus may be provided with a single or multiple alarm set points.
- NOTE 2 The hydrogen detection apparatus may include one or more built-in alarm indications, output contacts for alarm and/or electrical signals for alarm.
- 3.11**  
**hydrogen sensing element**  
component that provides a measurable, continuously changing physical quantity in correlation to the surrounding hydrogen volume fraction
- 3.12**  
**hydrogen sensor**  
assembly, which contains one or more hydrogen sensing elements and may also contain circuit components associated with the hydrogen sensing elements, that provides a continuously changing physical quantity or signal in correlation to the physical quantity provided by the hydrogen sensing element(s)

**3.13**

**hydrogen volume fraction**

hydrogen content expressed as the ratio of the volume of hydrogen to the total volume of all components in the gas mixture under standard conditions of temperature and pressure of 20 °C and 101,325 kPa

**3.14**

**interferant**

any substance that affects the sensitivity of a hydrogen sensing element by contacting or adhering to it

**3.15**

**latching alarm**

alarm that, once activated, requires deliberate manual action to be deactivated

**3.16**

**measuring range**

range, defined by the lowest and highest hydrogen volume fractions, within which a hydrogen detection apparatus can measure hydrogen volume fractions within the specified accuracy

**3.17**

**multi-level detection**

continuous detection and monitoring of hydrogen volume fraction with multiple alarm set points

**3.18**

**nominal supply voltage**

voltage corresponding to the manufacturer-recommended operating voltage for the hydrogen detection apparatus

**3.19**

**poisoning**

phenomenon caused by any interferant that permanently affects the sensitivity of a hydrogen sensing element

**3.20**

**remote hydrogen sensor**

hydrogen sensor that is remotely connected to a hydrogen detection apparatus

**3.21**

**selectivity**

response of the hydrogen detection apparatus to hydrogen compared with the response to other gases

NOTE If there is high selectivity to hydrogen, the results will be less ambiguous and the cross-sensitivity to other gases will be low.

**3.22**

**sensitivity**

ratio of change produced in the apparatus by a known volume fraction of hydrogen

NOTE 1 Depending on the context, this can refer to the minimum change in the volume fraction of hydrogen that the apparatus will detect.

NOTE 2 High sensitivity implies that low volume fractions can be measured.

**3.23**

**special state**

state of the hydrogen detection apparatus other than those in which monitoring of hydrogen volume fractions takes place, for example, warm-up, calibration mode or fault condition

**3.24**

**stabilization**

state in which three successive readings of a hydrogen detection apparatus, taken at 30 s intervals, indicate no changes greater than 5 % of the volume fraction of the test gas

### 3.25

#### test gas

mixture of hydrogen and clean air with a known volume fraction, which is used for performance tests of hydrogen detection apparatus

### 3.26

#### time of response

$t_{90}$   
time interval, with the hydrogen detection apparatus in a warmed-up condition, between the time when an instantaneous variation from clean air to the standard test gas is produced at the inlet of the remote hydrogen sensor or the integrated hydrogen sensor(s) and the time when the response reaches a stated percentage ( $x$ ) of the final indication

### 3.27

#### time of recovery

$t_{10}$   
time interval, with the hydrogen detection apparatus in a warmed-up condition, between the time when an instantaneous variation from the standard test gas to clean air is produced at the inlet of the remote hydrogen sensor or the integrated hydrogen sensor(s) and the time when the response decreases to a stated percentage ( $x$ ) of the final indication

### 3.28

#### warm-up time

time interval between the time when the hydrogen detection apparatus is switched on and the time when the special state indicator is turned off, showing that the hydrogen detection apparatus is in a warmed-up condition

## 4 General requirements

### 4.1 Construction

#### 4.1.1 General

The hydrogen detection apparatus designed to be used in a hazardous area shall comply with IEC 60079-0 and the relevant parts of IEC 60079.

#### 4.1.2 Enclosure

If the application demands it, all parts of the enclosure shall be constructed of corrosion-resistant materials or be protected against corrosion.

#### 4.1.3 Measuring range

The measuring range of the hydrogen detection apparatus shall be declared by the manufacturer. The measuring range shall cover a minimum of one order of magnitude. If the hydrogen detection apparatus uses two or more hydrogen sensor technologies or principles to cover a wide measuring range, the manufacturer shall declare the number of hydrogen sensors and/or specify the measuring range pertaining to each hydrogen sensor technology or principle.

#### 4.1.4 Alarm system

##### 4.1.4.1 Alarm

The hydrogen detection apparatus shall have at least one latching alarm with a fixed or adjustable alarm set point. If two or more alarm set points are provided, the lower may be non-latching, based on user preference. While the alarm condition is still present, the hydrogen detection apparatus shall be designed in such a way

that any alarms, except for optional audible alarms, shall remain in operation. Alarm devices shall be tamper-proof.

At least one alarm set point shall be available at or below a hydrogen volume fraction in air of  $1 \times 10^{-2}$ .

#### **4.1.4.2 Fault signals**

The hydrogen detection apparatus shall provide a fault signal in the event of loss of power. A short circuit or open circuit in the connection to any remote hydrogen sensor shall also be indicated by a fault signal. An aspirated hydrogen detection apparatus shall indicate the adequacy of flow conditions and produce a fault signal in the event of a flow failure.

#### **4.1.5 Indicators**

##### **4.1.5.1 Power indication**

The detection apparatus shall provide a visual power indicator that clearly indicates if the power to the hydrogen detection apparatus is on or off.

##### **4.1.5.2 Signals for recording**

For a hydrogen detection apparatus where the resolution of the read-out device is inadequate to demonstrate compliance with this International Standard, the manufacturer shall identify suitable points for connecting, indicating or recording devices for the purpose of testing the compliance of the hydrogen detection apparatus with this International Standard.

##### **4.1.5.3 Measuring range**

Any under-range or over-range measurements shall be clearly indicated.

If the hydrogen detection apparatus covers more than one measuring range, the measuring range selected shall be clearly identified.

All indications may be shown on the separate control unit.

##### **4.1.5.4 Indicating colours**

If only one indicating light is provided for alarm, fault or other indications, it shall be red in colour.

If separate indicating lights are used, the colour shall be used in the following order of priority:

- a) red for alarm indication;
- b) yellow for fault indication;
- c) green for operation.

In addition to the colour requirements, the indicator lights shall be labelled to show their functions.

#### **4.1.6 Adjustments**

All adjustment devices shall be designed so as to discourage unauthorized or inadvertent interference with the hydrogen detection apparatus. Examples would include procedural devices such as a keyboard instrument, or mechanical devices such as a cover requiring the use of a tool.

A fixed explosion-protected hydrogen detection apparatus or hydrogen sensor housed in explosion-protected enclosures shall be designed so that, if any facilities for adjustment are necessary for routine recalibration and

for resetting or similar functions, these facilities shall be externally accessible. The means for making adjustments shall not degrade the explosion protection of the hydrogen detection apparatus or hydrogen sensor.

The adjustments of the zero and signal amplification shall be so designed that adjustment of one will not affect the other.

#### **4.1.7 Software-controlled hydrogen detection apparatus**

##### **4.1.7.1 General**

In the design of software-controlled hydrogen detection apparatus, the risks arising from faults in the program shall be taken into account. In case of malfunction, a manual override switch shall be provided. The manual override switch shall be protected from use by unauthorized personnel.

##### **4.1.7.2 Conversion errors**

The relationship between corresponding analogue and digital values shall be unambiguous. The output range shall be capable of coping with the full range of input values within the instrument specification. A clear indication shall be provided if the conversion range is exceeded.

The design shall take into account the maximum possible analogue-to-digital, computational and digital-to-analogue converter errors. The combined effect of digitization errors shall not be greater than the smallest deviation of indication required by this International Standard.

##### **4.1.7.3 Special state indication**

All special states entered by the hydrogen detection apparatus shall be indicated by a contact or other transmittable output signal.

##### **4.1.7.4 Software**

The installed software version shall be identified, for example, by a marking on the installed memory component, a marking in (if accessible) or on the hydrogen detection apparatus, or a display during power-up or on user command.

It shall not be possible for the user to modify the program code.

Parameter settings shall be checked for validity. Invalid inputs shall be rejected. An access barrier shall be provided against parameter changing by unauthorized persons, e.g. it may be integrated by an authorization code in the software or may be realised by a mechanical lock. Parameter settings shall be preserved after removal of power, and while passing a special state. All user-changeable parameters and their valid ranges shall be listed in the software documentation.

Software shall have a structured design to facilitate testing and maintenance. If used, program modules shall have a clearly defined interface to other modules.

Software documentation shall be included in the technical file of the product. It shall include the following:

- a) the hydrogen detection apparatus to which the software belongs;
- b) identification of the software version;
- c) functional description;
- d) software structure (e.g. flow chart, Nassi-Schneidermann diagram);
- e) any software modification provided with the date of change and new identification data.

#### 4.1.7.5 Data transmission

Digital data transmission between spatially separated components of hydrogen detection apparatus shall be reliable. Delays resulting from transmission errors shall not extend the response time  $t_{90}$  by more than a third of the requirements specified in 6.4.13. If they do, the hydrogen detection apparatus shall pass over to a defined special state. The defined special state shall be documented in the instruction manual.

#### 4.1.7.6 Self-test routines

Digital components and digital functions shall incorporate self-test routines. On failure detection, the hydrogen detection apparatus shall pass over to a defined special state. The defined special state shall be documented in the instruction manual.

The following minimum self-test routines shall be performed by the hydrogen detection apparatus:

- a) the power supply of digital components shall be monitored within time intervals of a maximum of ten times the response time  $t_{90}$ ;
- b) monitoring equipment with its own time base (e.g. watchdog) shall work independently and separately from the parts of the digital components which perform the data processing;
- c) program and parameter memory shall be monitored by procedures which allow the detection of a single bit error;
- d) volatile memory shall be monitored by procedures that test the readability and writeability of the memory cells.

The tests shall be carried out automatically after the hydrogen detection apparatus is switched on and be repeated at regular intervals of 24 h or less.

All available visible and audible output functions shall be tested. The test shall be carried out automatically after starting the operation or on user request. The result may need to be verified by the user.

#### 4.1.7.7 Functional concept

The manufacturer shall provide the following documentation for functional concept analysis and evaluation:

- measuring sequence (including all possible variations);
- possible special states;
- parameters and their acceptable adjustment range;
- representation of measuring values and indications;
- generation of alarms and signals;
- extent and performance of self-test routines;
- extent and performance of remote data transmission.

#### 4.1.8 Reliability

A reliability analysis shall be conducted on the hydrogen detection apparatus in accordance with a recognized International Standard. The results of this reliability analysis, as well as the standard used, shall be recorded by the manufacturer.

## 4.2 Labelling and marking

The hydrogen detection apparatus and the remote hydrogen sensor, if used, shall be marked legibly and indelibly with the following minimum requirements:

- a) name and address, including the country of the manufacturer;
- b) a reference to this International Standard;
- c) designation of series or type;
- d) serial number;
- e) if applicable, specific marking describing the type of explosion protection in accordance with the relevant part of IEC 60079.

## 4.3 Instruction manual

Each hydrogen detection apparatus shall be provided with an instruction manual that includes the following information:

- a) complete instructions, drawings and diagrams for safe and proper operation, installation and servicing of the hydrogen detection apparatus;
- b) operating instructions and adjustment procedures;
- c) recommendations for initial checking and calibration of the hydrogen detection apparatus on a routine basis, including instructions for the use of the field calibration kit, if provided;
- d) measuring range of the hydrogen detection apparatus (see 4.1.3);
- e) details of operational limitations including, where applicable, the following:
  - 1) information that describes the sensitivities to other gases to which the hydrogen detection apparatus is responsive;
  - 2) temperature limits;
  - 3) humidity ranges;
  - 4) supply voltage limits;
  - 5) relevant characteristics and construction details of required interconnecting cables;
  - 6) battery data;
  - 7) pressure limits;
- f) recommended storage conditions (temperature, humidity, pressure) and storage-life limitations for the hydrogen detection apparatus, replacement parts and accessories;
- g) expected operation life-time;
- h) information on the adverse effects on the hydrogen sensor of poisons and interferants;
- i) for aspirated hydrogen detection apparatus, indication of the minimum and maximum flow rates and pressure, as well as the tubing type, maximum length and size for proper operation;
- j) for aspirated hydrogen detection apparatus, instructions for ensuring that the sample lines are intact and that proper flow is established;



- k) statements of the nature and significance of all alarms and fault signals, the duration of such alarms and signals (if time-limited or non-latching) and any provisions that may be made for silencing or resetting such alarms and signals, as applicable;
- l) details of any method for the determination of the possible sources of a malfunction and any corrective procedures (i.e. trouble-shooting procedures);
- m) identification of the alarm devices, outputs or contacts that are of the non-latching type, where applicable;
- n) recommended replacement-parts list;
- o) list of optional accessories (e.g. collecting cones, weather-protecting devices), if provided, and their identification (e.g. part numbers) as well as the description of their effects on the hydrogen detection apparatus characteristics (including response time and sensitivity);
- p) marking and any special conditions of service;
- q) any special instructions or information that are required due to the special nature of the hydrogen detection apparatus (such as non-linear responses);
- r) If applicable, instructions on the use of voice signal alarms, including the language of the recorded message;
- s) dos and don'ts clearly shown or illustrated.

#### **4.4 Vibration**

The manufacturer shall pack the hydrogen detection apparatus in such a manner as to prevent damage due to possible vibration during transportation. The hydrogen detection apparatus shall also be constructed to withstand the vibrations expected in its use.

### **5 Performance requirements**

The hydrogen detection apparatus shall meet the performance requirements specified in the tests defined in Clause 6.

## **6 Tests**

### **6.1 General requirements for tests**

#### **6.1.1 Number of samples**

The tests shall be carried out on one hydrogen detection apparatus for type testing, except as permitted by 6.1.2.

#### **6.1.2 Sequence of tests**

The hydrogen detection apparatus shall be subjected to all of the applicable tests specified in 6.4. The test sequence detailed below shall be followed:

- a) long-term stability, as in 6.4.4.2;
- b) operation above the measuring range, as in 6.4.16;
- c) poisoning, as in 6.4.15.

The other tests specified in 6.4 shall be carried out in a sequence to be defined by the manufacturer before and/or after the above sequence. For these tests, a sample which is different from the one used in the above sequence may be used.

### 6.1.3 Preparation of the hydrogen detection apparatus before testing

The hydrogen detection apparatus shall be prepared and mounted in a manner representative of the typical application, in accordance with the instruction manual, including all necessary interconnections, initial adjustments and initial calibrations. Adjustments may be made, where appropriate, at the beginning of each test.

Attachments, such as cone or weather protection, that are intended for optional use as indicated in the instruction manual shall not be attached to the hydrogen detection apparatus.

## 6.2 Test equipment

A diffusion chamber that can be sealed (see Annex A), or alternative facilities such as flow-type (see Annex B) or mask-type shall be used for the tests. If a flow-type or mask-type is used, the test procedure specific to that particular test method shall be followed.

When a mask is used for calibration or for the injection of test gas into the sensor, the design and operation of the mask (in particular the pressure and velocity inside the mask) shall not inadmissibly influence the response of the hydrogen detection apparatus or the results obtained.

The manufacturer of the hydrogen detection apparatus should be consulted when determining the design of the calibration mask. The manufacturer may provide a suitable calibration mask, together with details of suggested pressure or flow for application calibration gases, with the hydrogen detection apparatus.

If a test gas with a hydrogen volume fraction of 4 % or more is to be used, each component of the test equipment shall comply with the Zone I requirements of IEC 60079-0:2008.

## 6.3 Normal test conditions

### 6.3.1 Temperature

Unless otherwise specified, the tests shall be carried out at a temperature between 15 °C and 25 °C and the temperature shall be kept constant within  $\pm 2$  °C throughout the duration of the test.

### 6.3.2 Pressure

Unless otherwise specified, the tests shall be performed at pressures between 80 kPa and 108 kPa and the pressure shall be kept constant within  $\pm 1$  kPa throughout the duration of the test. For long-term tests, the influence of pressure changes shall be taken into account using the results of the pressure test of 6.4.7.

### 6.3.3 Humidity

Unless otherwise specified, the tests shall be carried out at a relative humidity (RH) between 20 % and 80 % and the RH shall be maintained constant within  $\pm 10$  % throughout the duration of the test.

### 6.3.4 Voltage

Unless otherwise specified, mains-powered and fixed direct-current (DC)-powered hydrogen detection apparatus shall be operated within 2 % of the manufacturer's recommended supply voltage and frequency.

### 6.3.5 Orientation

The hydrogen detection apparatus shall be tested in the orientation recommended by the manufacturer.

## 6.4 Test methods

### 6.4.1 General

This International Standard is not intended to exclude any specific technologies that meet the performance requirements herein. In the event that a test method defined in this International Standard is not suitable for a specific technology, an alternative test method may be used. In this case, the alternative test method and results shall be reported.

### 6.4.2 Standard response test

#### 6.4.2.1 Standard test gas

The tests shall be conducted using a single test gas per one order of magnitude in the measuring range with a hydrogen volume fraction at the midpoint of that order. If the measuring range is less than two orders of magnitude, then the test shall be conducted with a single test gas having a hydrogen volume fraction at the midpoint of the measuring range. If the measuring range is more than two but less than three orders of magnitude, then two test gases shall be used. When the hydrogen detection apparatus uses two or more types of sensors covering different measuring ranges, the tests shall be conducted using two or more test gases with a hydrogen volume fraction at the midpoint of each measuring range. For any range of two or more orders of magnitude, one test gas per order of magnitude shall be used.

All gases used in testing described in this International Standard should be of certified reagent grade traceable to a national or International Standard such as Grade A of ISO 14687-1:1999.

For test gases with a hydrogen volume fraction of  $10^{-3}$  or higher, the relative tolerance shall be  $\pm 5\%$  and known to be within  $\pm 2\%$ , and for those gases with a hydrogen volume fraction of less than  $10^{-3}$ , the relative tolerance shall be  $\pm 10\%$  and known to be within  $\pm 2\%$ .

If the hydrogen volume fraction of the test gas is within the explosion range, hydrogen may be mixed with nitrogen, provided that the measuring function of the hydrogen detection apparatus is not affected by oxygen deficiency. Otherwise, the hydrogen volume fraction of the standard test gas may be taken outside the explosive range as near as possible to the values stated above.

#### 6.4.2.2 Procedure

The remote hydrogen sensor or the integrated hydrogen sensor shall be exposed to clean air until the atmosphere stabilizes at the normal test conditions. The indication shall be recorded as the offset value. The atmosphere shall be changed to the test gas, and the final indication shall be recorded (see Annexes A and B for details).

### 6.4.3 Measuring range and calibration

#### 6.4.3.1 Initial preparation of the hydrogen detection apparatus

If necessary, the hydrogen detection apparatus shall be calibrated and adjustments shall be carried out to obtain correct indications in accordance with the manufacturer's instruction manual.

#### 6.4.3.2 Validation of accuracy (calibration curve)

Calibration and adjustment shall be performed according to the manufacturer's recommended specifications. Validation shall be performed with five points or more per order of magnitude of the measuring range. Additional orders of magnitudes shall be validated with at least four additional points per each order of magnitude. For a measuring range of less than two orders of magnitude, a minimum of five test hydrogen volume fractions shall be used, but additional testing points can be added, as needed. The hydrogen volume fractions may be equally distributed or as otherwise needed. The hydrogen detection apparatus shall be exposed in ascending order to each hydrogen volume fraction of the test gas for 3 min without exposure to

clean air between the hydrogen volume fractions. Following the highest hydrogen volume fraction, the hydrogen detection apparatus shall be exposed to clean air for 10 min. This operation shall be carried out three times consecutively. For all measurements, the variation of the final indication from the hydrogen volume fraction of the test gas shall not exceed the following:

- a) for a test gas with a hydrogen volume fraction of  $1 \times 10^{-4}$  and lower: less than the variation declared by the manufacturer in the instruction manual;
- b) for a test gas with a hydrogen volume fraction higher than  $1 \times 10^{-4}$  and up to a maximum of  $5 \times 10^{-4}$ :  $\pm 1,25 \times 10^{-4}$  or  $\pm 50$  % of the hydrogen volume fraction of the test gas, whichever is less;
- c) for a test gas with a hydrogen volume fraction higher than  $5 \times 10^{-4}$  and up to a maximum of  $4 \times 10^{-2}$ :  $\pm 6 \times 10^{-3}$  or  $\pm 25$  % of the hydrogen volume fraction of the test gas, whichever is less;
- d) for a test gas with a hydrogen volume fraction higher than  $4 \times 10^{-2}$ : less than the variation declared by the manufacturer in the instruction manual.

**NOTE** For hydrogen detection apparatus that does not indicate hydrogen volume fractions lower or higher than the manufacturer's declared measuring range, the test gas at the lower end or the upper end may be corrected by the respective tolerance. For example, if the hydrogen detection apparatus with a declared measuring range of  $1 \times 10^{-3}$  to  $4 \times 10^{-2}$  has no hydrogen volume fraction indications higher than  $4 \times 10^{-2}$ , a test gas with a hydrogen volume fraction of  $3,4 \times 10^{-2}$  (by subtracting the tolerance limit of  $0,6 \times 10^{-3}$  from  $4 \times 10^{-2}$ ) can be used.

#### 6.4.4 Stability

##### 6.4.4.1 Repeatability

The standard response test of 6.4.2 shall be carried out five times consecutively by exposing the hydrogen detection apparatus to the test gas for 150 s, followed by an exposure to clean air for 300 s, after the atmosphere is completely replaced. At the end of 150 s of exposure to the test gas, the final indication for the test gas shall be collected.

For each of the tests, the short-term variation of the final indication for the test gas shall not exceed the following:

- a) for a test gas with a hydrogen volume fraction of  $1 \times 10^{-3}$  or higher:  $\pm 10$  % of the hydrogen volume fraction of the test gas;
- b) for a test gas with a hydrogen volume fraction of lower than  $1 \times 10^{-3}$ :  $\pm 5 \times 10^{-5}$  or  $\pm 10$  % of the hydrogen volume fraction of the test gas, whichever is larger.

##### 6.4.4.2 Long-term stability

The hydrogen detection apparatus shall be operated continuously in clean air for a period of three months. At the end of every two weeks over the three-month period, the standard response test described in 6.4.2 shall be carried out and the final indication for the test gas shall be recorded.

The long-term variation of the final indication for the test gas shall not exceed the following:

- a) for a test gas with a hydrogen volume fraction of  $1 \times 10^{-3}$  or higher:  $\pm 30$  % of the hydrogen volume fraction of the test gas;
- b) for a test gas with a hydrogen volume fraction lower than  $1 \times 10^{-3}$ :  $\pm 5 \times 10^{-5}$  or  $\pm 30$  % of the hydrogen volume fraction of the test gas, whichever is larger.

## 6.4.5 Alarm set point(s)

### 6.4.5.1 General

Whether the hydrogen detection apparatus is provided with internally pre-set alarm point(s) or externally adjustable means of setting one or more alarm set points, the activation of such alarms by hydrogen gas at the appropriate set point values shall be verified by using test gases as described in 6.4.5.2.

For hydrogen detection apparatus with several alarm set points, this test shall be carried out for each alarm set point.

### 6.4.5.2 Increasing hydrogen volume fraction

For externally adjustable alarm set points, the alarm set point shall be set at 50 % below the hydrogen volume fraction of the test gas specified in 6.4.2.1, with the indication tolerance taken into consideration. If the alarm set point cannot be set at this hydrogen volume fraction, the alarm shall be set as near as possible to this hydrogen volume fraction. In this case and for internally pre-set alarm points, the test gas shall have a hydrogen volume fraction of 50 % above the alarm set point. The hydrogen sensor shall be exposed to clean air and then to the test gas.

The alarm(s) shall be checked to verify that they are active. When the hydrogen detection apparatus utilizes manual reset action, the manual reset function shall be checked after activation of the alarms.

## 6.4.6 Temperature

### 6.4.6.1 Test condition

This test shall be performed in a test chamber capable of maintaining the ambient temperature surrounding the hydrogen detection apparatus to within  $\pm 2$  °C of the specified temperature. When the temperature inside the test chamber, including the hydrogen detection apparatus, has reached the specified temperature and stabilized, the hydrogen detection apparatus shall be subjected to the standard response test of 6.4.2. using clean air and a test gas at the same temperature as the atmosphere in the test chamber. In order to avoid condensation, the dew point of the clean air or the test gas shall be below the lowest temperature of the test chamber and shall be kept constant during the test.

Hydrogen detection apparatus with a remote hydrogen sensor shall be tested in the following conditions:

- a) the remote hydrogen sensor shall be tested in air and in the test gas at  $-20$  °C,  $20$  °C and  $50$  °C;
- b) the control unit of the hydrogen detection apparatus shall be tested in air and in the test gas at  $5$  °C,  $20$  °C and  $50$  °C.

Hydrogen detection apparatus with an integrated hydrogen sensor shall be tested in air and in the test gas at  $-10$  °C,  $20$  °C, and  $50$  °C.

### 6.4.6.2 Requirement

The variation of the final indication obtained from the test at each specific temperature from that obtained at  $20$  °C shall not exceed the following:

- a) for a test gas with a hydrogen volume fraction of  $1 \times 10^{-3}$  or higher:  $\pm 20$  % of the hydrogen volume fraction of the test gas;
- b) for a test gas with a hydrogen volume fraction lower than  $1 \times 10^{-3}$ :  $\pm 5 \times 10^{-5}$  or  $\pm 20$  % of the hydrogen volume fraction of the test gas, whichever is larger.

Hydrogen detection apparatus intended for use in a special environment shall be tested in this special environment. Such conditions for testing shall be noted in the instruction manual.

#### 6.4.7 Pressure

The effects of the pressure variation shall be observed by placing the hydrogen detection apparatus (including the aspirator for aspirated hydrogen detection apparatus) in a test chamber that permits the pressure of the atmosphere to be varied.

The standard response tests shall be carried out at pressures of 100 kPa, 80 kPa and 110 kPa with a tolerance of  $\pm 3$  kPa. The pressure shall be maintained at the specified levels for 5 min before starting each test.

The variation of the final indications at 80 kPa and 110 kPa from the final indication at 100 kPa shall not exceed the following:

- a) for a test gas with a hydrogen volume fraction of  $1 \times 10^{-3}$  or higher:  $\pm 30$  % of the hydrogen volume fraction of the test gas;
- b) for a test gas with a hydrogen volume fraction lower than  $1 \times 10^{-3}$ :  $\pm 5 \times 10^{-5}$  or  $\pm 30$  % of the hydrogen volume fraction of the test gas, whichever is larger.

#### 6.4.8 Humidity

The test shall be carried out at a relative humidity of 20 %, 50 %, and 80 % with a tolerance of  $\pm 3$  %. The hydrogen detection apparatus shall be allowed to stabilize first at  $40 \text{ }^\circ\text{C} \pm 2 \text{ }^\circ\text{C}$  and a relative humidity of 50 %. After stabilizing it shall be adjusted according to the instructions of the manufacturer. For each humidity level, the hydrogen detection apparatus shall be exposed for 15 min or longer to clean air and then to the test gas at the same humidity as the test chamber.

The hydrogen volume fraction of the test gas shall be held constant, or due allowance shall be made for any changes in the hydrogen volume fraction by the water vapour pressure.

The variation of the final indications at relative humidity of 20 % and 80 % from the final indication at a relative humidity of 50 % and  $40 \text{ }^\circ\text{C}$ , shall not exceed the following:

- a) for a test gas with a hydrogen volume fraction of  $1 \times 10^{-3}$  or higher:  $\pm 30$  % of the hydrogen volume fraction of the test gas;
- b) for a test gas with a hydrogen volume fraction lower than  $1 \times 10^{-3}$ :  $\pm 5 \times 10^{-5}$  or  $\pm 30$  % of the hydrogen volume fraction of the test gas, whichever is larger.

#### 6.4.9 Vibration

##### 6.4.9.1 Test equipment

The vibration test machine shall consist of a vibrating table capable of producing a vibration of variable frequency and variable constant displacement (peak-to-peak), with the test apparatus mounted in place, as required by the following test procedures.

##### 6.4.9.2 Procedures

The hydrogen detection apparatus shall be mounted on the vibration table in the same manner as intended for service use including any resilient mounts, and carrier or holding devices that are provided as standard parts of the hydrogen detection apparatus.

The alarm set point shall be set to 20 % of the highest value of the measuring range.

The hydrogen detection apparatus shall be energized and mounted on the vibration test machine and vibrated successively in each of three planes respectively parallel to each of the three major axes of the hydrogen detection apparatus.

The hydrogen detection apparatus shall be vibrated over the frequency range specified at the excursion or constant acceleration peak specified in 6.4.9.3, for a period of 1 h in each of the three mutually perpendicular planes. The rate of change of frequency shall not exceed 10 Hz/min.

Before and at the conclusion of the test, the hydrogen detection apparatus shall be exposed to clean air followed by the standard test gas.

#### 6.4.9.3 Vibration levels

For remote hydrogen sensors or hydrogen detection apparatus with an integrated hydrogen sensor, the vibration shall be as follows:

- 10 Hz to 30 Hz, 1,0 mm total excursion;
- 31 Hz to 150 Hz, 19,6 m/s<sup>2</sup> acceleration peak.

For the control unit of hydrogen detection apparatus with a remote hydrogen sensor, the vibration shall be as follows:

- 10 Hz to 30 Hz, 1,0 mm total excursion;
- 31 Hz to 100 Hz, 19,6 m/s<sup>2</sup> acceleration peak.

#### 6.4.9.4 Tolerance

The variation of the final indications before applying the vibration and after applying the vibration shall not exceed the following:

- a) for a test gas with a hydrogen volume fraction of  $1 \times 10^{-3}$  or higher:  $\pm 20\%$  of the hydrogen volume fraction of the test gas;
- b) for a test gas with a hydrogen volume fraction lower than  $1 \times 10^{-3}$ :  $\pm 1 \times 10^{-4}$  or  $\pm 20\%$  of the hydrogen volume fraction of the test gas, whichever is larger.

The hydrogen detection apparatus shall not experience any loss of function, fault signal, nor damage resulting in a hazard or false alarm.

#### 6.4.10 Orientation

The remote hydrogen sensor or the hydrogen detection apparatus with an integrated hydrogen sensor shall be tested with clean air and standard test gas at the nominal orientation and at an angle within the orientation limits stated in the manufacturer's instructions, but in no case at less than  $\pm 15^\circ$  from the nominal orientation.

The variation of the final indication obtained at the oriented state from that obtained at the nominal orientation shall not exceed the following:

- a) for a test gas with a hydrogen volume fraction of  $1 \times 10^{-3}$  or higher:  $\pm 20\%$  of the hydrogen volume fraction of the test gas;
- b) for a test gas with a hydrogen volume fraction lower than  $1 \times 10^{-3}$ :  $\pm 1 \times 10^{-4}$  or  $\pm 20\%$  of the hydrogen volume fraction of the test gas, whichever is larger.

#### 6.4.11 Flow rate for aspirated apparatus

The aspirated hydrogen detection apparatus shall be subjected to the standard response test by varying the flow rate of the test gas:

- from 130 % of the nominal flow rate with a tolerance of  $\pm 5$  % or, if this is not possible, from the nominal flow rate;
- to 50 % of the nominal flow rate with a tolerance of  $\pm 5$  %, or to the flow rate that will initiate the fault signal specified in 4.1.4.2, if this is higher.

The variations of the final indications under upper flow limit and lower flow limit from the final indication under nominal flow rate shall not exceed the following:

- a) for a test gas with a hydrogen volume fraction of  $1 \times 10^{-3}$  or higher:  $\pm 20$  % of the hydrogen volume fraction of the test gas;
- b) for a test gas with a hydrogen volume fraction lower than  $1 \times 10^{-3}$ :  $\pm 1 \times 10^{-4}$  or  $\pm 20$  % of the hydrogen volume fraction of the test gas, whichever is larger.

#### 6.4.12 Air velocity

##### 6.4.12.1 Test condition

The effects of air velocity shall be evaluated by placing the remote hydrogen sensor or the hydrogen detection apparatus with an integrated hydrogen sensor in a flow chamber suitable for the application of clean air and the standard test gas. Hydrogen detection apparatus with integrated hydrogen sensors that are too large to be tested in a flow chamber may be tested with other flow apparatus. Irrespective of whether a flow chamber or other flow apparatus are used, the gas inlet of the remote hydrogen sensor or the hydrogen detection apparatus with (an) integrated hydrogen sensor(s) shall be oriented in relation to the direction of the air flow as follows:

- a) sensor oriented directly in the direction of flow;
- b) sensor oriented away from the direction of flow;
- c) sensor oriented at right angles to the direction of flow.

NOTE Directions of flow that are not likely to occur in practice due to the design of the hydrogen detection apparatus or which are expressly prohibited in the manufacturer's instruction manual can be exempted from the test.

Measurements shall be taken under static conditions and at air velocities of 3 m/s and 6 m/s with a tolerance of  $\pm 0,2$  m/s.

##### 6.4.12.2 Requirement

The variation of the final indication at 3 m/s and 6 m/s air velocity from the final indication under zero air velocity shall not exceed the following:

- a) for a test gas with a hydrogen volume fraction of  $1 \times 10^{-3}$  or higher:  $\pm 20$  % of the hydrogen volume fraction of the test gas;
- b) for a test gas with a hydrogen volume fraction lower than  $1 \times 10^{-3}$ :  $\pm 30$  % of the hydrogen volume fraction of the test gas.



### 6.4.13 Time of response and time of recovery

The hydrogen detection apparatus shall be switched on in clean air and, after an interval corresponding to at least two times the warm-up time, without switching off, the hydrogen detection apparatus or the remote sensor shall be subjected to step changes from clean air to the standard test gas and from standard test gas to clean air. These changes shall be introduced by means of suitable equipment.

The time of response  $t_{90}$  shall be 30 s or less.

The time of recovery  $t_{10}$  shall also be measured. The time of recovery  $t_{10}$  shall be 60 s or less.

The data-collecting interval should be less than 1 s to evaluate  $t_{90}$  and  $t_{10}$ .

### 6.4.14 Selectivity

The sensitivity of the hydrogen detection apparatus to other gases shall be evaluated using the test procedure specified in 6.4.2.2, except that the gases listed in Table 1 shall be used instead of the test gas. Each gas listed in Table 1 shall be tested individually without hydrogen.

**Table 1 — Gases used in testing a hydrogen detection apparatus for sensitivity to other gases**

Gases	Volume fraction (in air)
Methane	$5 \times 10^{-4} \pm 2 \times 10^{-5}$
Isooctane	$5 \times 10^{-4} \pm 2 \times 10^{-5}$
Carbon monoxide	$5 \times 10^{-4} \pm 2 \times 10^{-5}$

When the selectivity against gases not listed in the table is enhanced by the manufacturer, the hydrogen detection apparatus shall additionally be tested for these gases.

The final indication for the specified gases listed in Table 1 shall not exceed 10 % of the final indication of the standard response test.

If the hydrogen detection apparatus fails this test but is in compliance with all the other requirements stipulated in this International Standard, the hydrogen detection apparatus may be deemed in compliance with this International Standard provided non-compliance to the selectivity test is clearly stated in the test report and instruction manual.

### 6.4.15 Poisoning

The remote hydrogen sensor or hydrogen detection apparatus with an integrated hydrogen sensor shall be subjected to the poisoning test with each gas shown in Table 2. If improved tolerance to any of the above gases is claimed by the manufacturer, the test for that gas shall be performed at the tolerance level specified by the manufacturer. Tests for HMDS, SO<sub>2</sub>, H<sub>2</sub>S and NO<sub>2</sub> may be carried out with dry gas.

**Table 2 — List of gases used for the poisoning test**

Gases	Volume fraction (in air)
Hexamethyldisiloxane (HMDS)	$1 \times 10^{-5} \pm 3 \times 10^{-6}$
SO <sub>2</sub>	$5 \times 10^{-4} \pm 15 \times 10^{-5}$
H <sub>2</sub> S	$5 \times 10^{-5} \pm 15 \times 10^{-6}$
NO <sub>2</sub>	$2 \times 10^{-5} \pm 6 \times 10^{-6}$

The remote hydrogen sensor or hydrogen detection apparatus, with an integrated hydrogen sensor in working condition shall be exposed to each of the gases shown in Table 2 for 60 min. After the 60 min period, the remote hydrogen sensor or hydrogen detection apparatus with an integrated hydrogen sensor in working condition shall be exposed to clean air for 60 min followed by the standard response test of 6.4.2.

The variation of the final indication of the standard response test after the poisoning test from the final indication of the standard response test before the poisoning test shall not exceed  $\pm 20$  %.

#### 6.4.16 Operation above the measuring range

The hydrogen detection apparatus with an integrated or remote hydrogen sensor shall be subjected to a step change from clean air to a test gas with a minimum hydrogen volume fraction corresponding to Grade A of ISO 14687-1:1999 (almost 100 %) or to ten times or more of the upper limit of the measuring range.

The measurement method using the small box described in Annex A may be used for this test.

The Grade A hydrogen volume fraction shall be maintained for 3 min. The sensor indication shall be 100 % of the measuring range or over the measuring range throughout the 3 min period of exposure to the Grade A hydrogen volume fraction. The latching alarm shall be activated when the alarm set point is reached.

The remote hydrogen sensor or the hydrogen detection apparatus with an integrated hydrogen sensor(s) shall then be subjected to ambient air for 20 min, and then the indication shall be recorded, followed by the standard response test of 6.4.2.

The indication measured at an elapsed time of 20 min after the exposure to the ambient air shall be below the lowest limit of the measuring range. Any difference between the final indication of the standard response test of 6.4.2 and the hydrogen volume fraction of the test gas shall not exceed the tolerance given in the calibration test.

**WARNING — Safety precautions shall be taken in the handling of gases with hydrogen volume fraction above the lower flammability limit.**

#### 6.4.17 Power supply variations

The hydrogen detection apparatus shall be set up under normal test conditions as specified in 6.3, at nominal supply voltage and, where appropriate, rated frequency. For a hydrogen detection apparatus with a remote hydrogen sensor, the test shall be performed twice, once with an interconnecting cable with maximum resistance and once with an interconnecting cable with minimum resistance.

The hydrogen detection apparatus shall be subjected to the standard response test of 6.4.2, carried out at both 80 % and 115 % of the nominal supply voltage.

Where the manufacturer of the hydrogen detection apparatus specifies a supply voltage range other than those specified above, the hydrogen detection apparatus shall be tested at the upper and lower limits of the supply voltage specified by the manufacturer.

The variation of the final indications at 80 % and 115 % of the nominal supply voltage from the final indication at the nominal supply voltage shall not exceed the following:

- a) for a test gas with a hydrogen volume fraction of  $1 \times 10^{-3}$  or higher:  $\pm 10$  % of the hydrogen volume fraction of the test gas; or
- b) for a test gas with a hydrogen volume fraction lower than  $1 \times 10^{-3}$ :  $\pm 5 \times 10^{-5}$  or  $\pm 10$  % of the hydrogen volume fraction of the test gas, whichever is larger.

## 6.4.18 Power supply interruptions, voltage transients and step changes of voltage

### 6.4.18.1 General

The hydrogen detection apparatus shall be set up under the normal conditions specified in 6.3 and, if possible, the alarm set point shall be set to 20 % of the upper limit of the measuring range. The hydrogen detection apparatus shall then be subjected to the tests specified in 6.4.18.2 to 6.4.18.4 in clean air. The hydrogen detection apparatus shall not yield spurious alarms throughout the tests.

### 6.4.18.2 Short interruption of power supply

The power supply shall be interrupted for 10 ms, repeated 10 times at random intervals having a mean value of 10 s.

### 6.4.18.3 Voltage transients

The hydrogen detection apparatus shall be tested according to IEC 61000-4-4, test severity 2. The test procedure for type tests to be performed in testing bodies shall be used. The test duration shall be 1 min for each line or terminal to be tested.

### 6.4.18.4 Step changes of voltage without interruption

For alternating current (AC) and external direct current (DC) powered hydrogen detection apparatus, the power voltage shall be increased by 10 %, maintained at this value until the hydrogen detection apparatus is stabilized, and then reduced to 15 % below nominal voltage. Each step change shall take place within 10 ms.

## 6.4.19 Warm-up time after restart

The hydrogen detection apparatus shall be switched off and left in clean air for at least 30 min. The hydrogen detection apparatus shall be switched on in clean air and the warm-up time shall be measured. As required by 4.1.7.3, the warm-up mode shall be indicated as a special state and the hydrogen detection apparatus shall automatically switch to the measuring mode within 5 min. After the 5 min period in clean air, the hydrogen detection apparatus shall be immediately exposed to the standard response test of 6.4.2. The variation of the final indication shall not exceed the following:

- a) for a test gas with a hydrogen volume fraction of  $1 \times 10^{-3}$  or higher:  $\pm 20$  % of the hydrogen volume fraction of the test gas; or
- b) for a test gas with a hydrogen volume fraction lower than  $1 \times 10^{-3}$ :  $\pm 5 \times 10^{-5}$  or  $\pm 20$  % of the hydrogen volume fraction of the test gas, whichever is larger.

## 6.4.20 Electromagnetic immunity

If possible, the alarm set point shall be set to 20 % of the measuring range for this test. The hydrogen detection apparatus, including the hydrogen sensor and interconnecting wiring, shall be subjected to the test method used in the EMC radiated immunity tests specified in IEC 61000-4-1 and IEC 61000-4-3.

The test requirements shall be carried out with severity level 2; test field strength of 3 V/m.

In the case of field systems with remote hydrogen sensors where the hydrogen detection apparatus (main unit) is intended for general-purpose rack mounting or its equivalent, such a hydrogen detection apparatus unit shall be submitted to these tests in the enclosure supplied by the manufacturer.

The instruction manual shall inform the user that such hydrogen detection apparatus is to be used with the same enclosure to avoid adverse electromagnetic effects.

Electromagnetic emission requirements may be required by other standards.

When subjected to the electromagnetic immunity test, the hydrogen detection apparatus shall be subjected to the standard response test in 6.4.2. The variation of the final indication shall not exceed  $\pm 10\%$  of the hydrogen volume fraction of the test gas. The hydrogen detection apparatus shall also suffer no loss of function or spurious alarm.

#### 6.4.21 Field calibration kit

##### 6.4.21.1 Test condition

If a field calibration kit is provided with the hydrogen detection apparatus, the following test shall be carried out:

- a) calibrate the hydrogen detection apparatus in accordance with 6.4.3 in the test conditions given in 6.3 and using the test equipment for the tests described in 6.4;
- b) use the field calibration kit in a manner corresponding to the manufacturer's instructions for checking the response of the hydrogen detection apparatus.

##### 6.4.21.2 Requirement

The tolerances shall be as follows:

- a) for a test gas with a hydrogen volume fraction of  $1 \times 10^{-3}$  or higher:  $\pm 15\%$  of the hydrogen volume fraction of the test gas;
- b) for a test gas with a hydrogen volume fraction lower than  $1 \times 10^{-3}$ :  $\pm 5 \times 10^{-5}$  or  $\pm 20\%$  of the hydrogen volume fraction of the test gas, whichever is larger.

## Annex A (informative)

### Chamber test method

#### A.1 Basic set up

The diffusion chamber should have an internal volume of around 30 l or larger. When it is necessary to use a diffusion chamber of different size for several tests, this should be reported. In all cases, the internal volume of the diffusion chamber should be known. The diffusion chamber should be constructed in such a manner that the intrusion of ambient air or leakage from the diffusion chamber will not occur. The diffusion chamber should be provided with a gas inlet for the test gas and wire ports and these should be sealed to prevent leakage. The temperature and humidity of the atmosphere in the chamber should be monitored.

A fan that has a flow rate of 0,5 m<sup>3</sup>/s or larger should be placed in the diffusion chamber in front of the gas inlet, facing outwards. The fan should be run continuously with a wind speed of 3 m/s or greater. The fan should be stopped during measurements.

NOTE The largest value of the wind speed measured in front of the fan is applicable.

The remote hydrogen sensor or the hydrogen detection apparatus with an integrated hydrogen sensor(s) should be placed in the diffusion chamber so as not to block the flow from the fan. The control unit of a hydrogen detection apparatus with a remote hydrogen sensor may be located outside the chamber. After warm-up and stabilization of the hydrogen detection apparatus, the calculated volume of pure hydrogen gas should be injected through the inlet of the diffusion chamber and several seconds should be allowed for the hydrogen volume fraction in the diffusion chamber to homogenize. The agitating fan should be run constantly during these procedures. The appropriate waiting time should be determined beforehand by finding the elapsed time until the hydrogen volume fraction stabilized. After the waiting period, measurement should be started.

#### A.2 Standard response test

The following procedure should be used for the standard response test.

- a) Position the remote hydrogen sensor or hydrogen detection apparatus with an integrated hydrogen sensor in the diffusion chamber, then wire and activate it.
- b) Purge the diffusion chamber with clean air and then seal it. The fan should be run until the atmosphere stabilizes at the normal test conditions specified in 6.3.
- c) Inject the hydrogen gas with a minimum hydrogen volume fraction corresponding to Grade A of ISO 14687-1:1999 (almost 100 %) through the gas inlet of the diffusion chamber and, as the atmosphere changes to the test gas, record the final indication.
- d) the test gas should be completely replaced with clean air.

If a pressure increase is significant, wait until the hydrogen volume fraction becomes uniform in the chamber, and then release the hydrogen gas through the gas inlet or otherwise to solve the problem.

In the case of testing by a diffusion chamber, the saturated salt solution method (OIML R 121<sup>[17]</sup>) may be used to control the humidity of the atmosphere. A precise volume (collected by a syringe or through controlled time-flow parameters) of pure hydrogen is injected into the chamber.

### A.3 Time of response and recovery

A small open box that can contain the remote hydrogen sensor or the hydrogen detection apparatus with an integrated hydrogen sensor(s) should be used for this test. An example of the box is shown in Figure A.1. It is an acrylic plastic box (70 mm × 70 mm × 50 mm). The box should be sealed by a rubber film, and then placed in the diffusion chamber.

The procedure should be as follows.

- a) The remote hydrogen sensor or the hydrogen detection apparatus with an integrated hydrogen sensor(s) should be placed in the box and wired, then the box should be sealed.
- b) The box should be placed in a diffusion chamber that meets the requirements of A.1, and the conditions should be set according to the standard response test of A.2.
- c) Allow the atmosphere in the diffusion chamber to stabilize for a minimum of 5 min. After stabilization, record, as the offset, the data for clean air in accordance with A.2.
- d) The atmosphere in the diffusion chamber should be changed from clean air to the test gas, and it should be homogenized.
- e) The small box should be opened quickly, and the time of response  $t_{90}$  should be evaluated and recorded. Any suitable method could be used to open the small box quickly, such as cutting the seal or otherwise.

The recovery time could be tested in the chamber method by opening the chamber to replace the hydrogen containing air with environmental air. For a more precise test, a flow-type test method is recommended. An example of a flow-type test method is described in Annex B.

Dimensions in millimetres

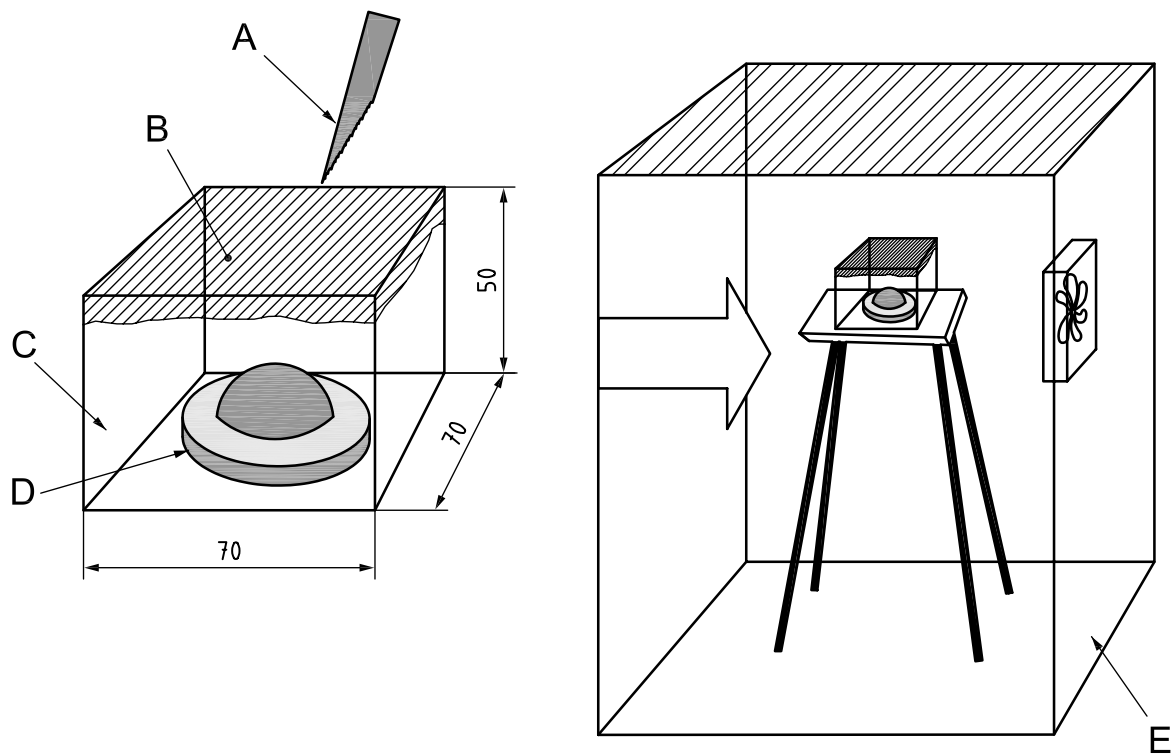

**Key**

- A cutter
- B rubber film
- C small box
- D remote hydrogen sensor or hydrogen detection apparatus with (an) integrated hydrogen sensor(s)
- E diffusion chamber

**Figure A.1 — Small box used for the time of response test**

## Annex B (informative)

### Flow-through test method

#### B.1 Selection of the series or parallel arrangements

Because some sensors consume hydrogen (which could potentially affect the reading of downstream sensors in a series arrangement), this should be taken into consideration when deciding which type of arrangement (series or parallel) to use for the flow-through test method.

#### B.2 Series arrangement

For a series arrangement, the hydrogen sensor(s) should be placed in a test manifold (per Figure B.1), which is a tube of nominal 25 mm inside diameter with close-coupled flanges arranged at 45° from vertical and 90° from the direction of flow.

NOTE For more than two sensors under test, additional test manifolds can be required.

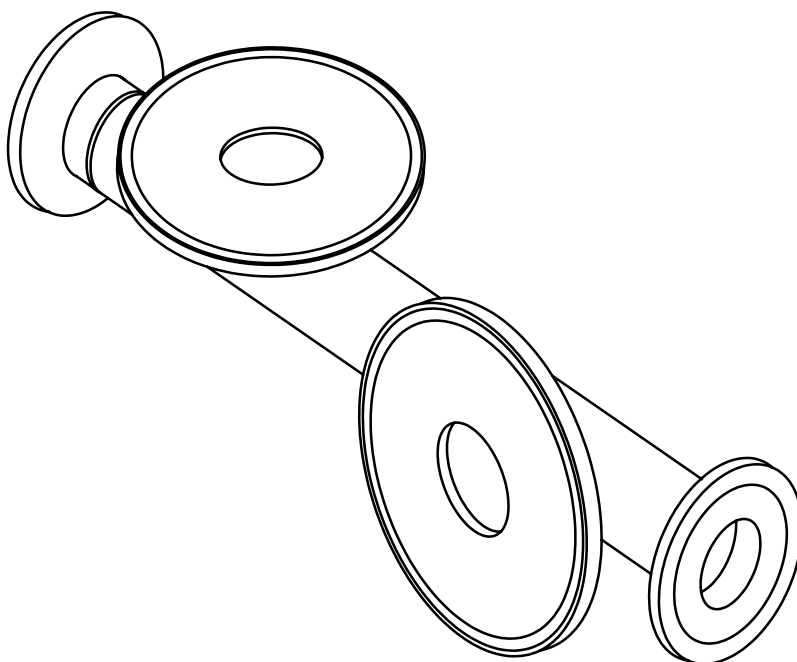

Figure B.1 — Test manifold (two sensors only)

The test manifold should be placed in the flow-through test set-up (per Figure B.2). The test set-up should contain a test gas selector and switch, which are used for the control of test gases to be used. The test gas should then flow through a mass flow controller (for control and measurement of gas flow rate), a back-pressure regulator (to regulate any pressure differences coming from the test gas supply) and manifold inlet sensors (temperature, pressure, humidity, etc.), before entering the test manifold. In the test manifold, the test gas should pass by the hydrogen sensors in series (reference sensor No. 1, test sensor No. 1, test sensor No. 2 and reference sensor No. 2). At the outlet of the test manifold, the test gas should pass by the manifold outlet sensors and another back-pressure regulator, before being vented to ambient air.



NOTE 1 The overall test-gas flow rate and speed are important for time-of-response testing. This set-up can be adapted for a multitude of different test conditions, including variability of flow rate, temperature, pressure, humidity and gas composition.

NOTE 2 The series arrangement with reference sensors at the inlet and outlet of the test manifold tends to provide good detection with respect to consumption of hydrogen by upstream sensors. That is, if the reference sensors both provide the same reading (within tolerance), then it can safely be assumed that the consumption of hydrogen by upstream sensors does not have an adverse effect on downstream sensors.

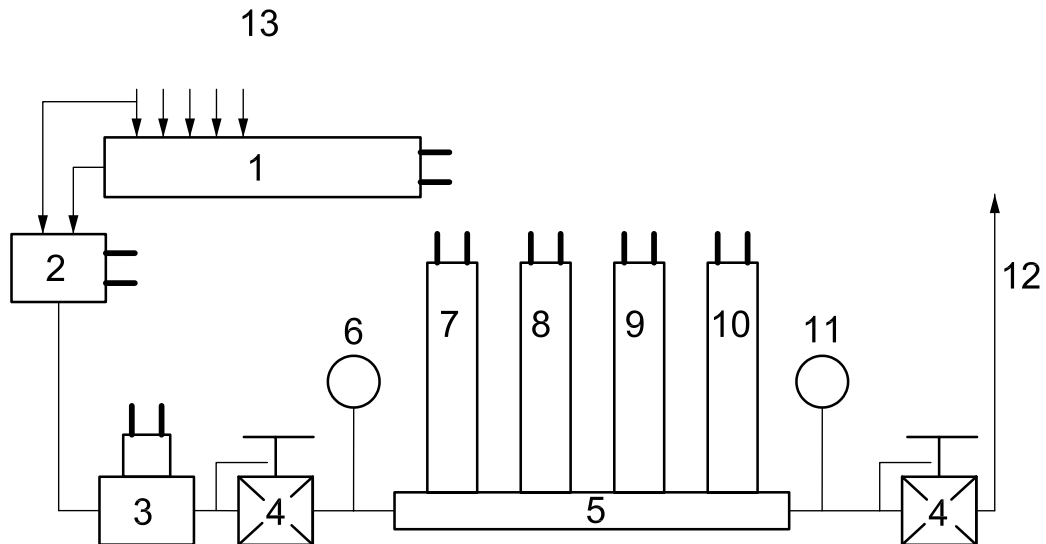

**Key**

- |   |  |    |   |
|---|--|----|---|
| 1 | test-gas selector  | 8  | test sensor No. 1   |
| 2 | switch   | 9  | test sensor No. 2   |
| 3 | mass flow controller (MFC)                                     | 10 | reference sensor No. 2  |
| 4 | back-pressure regulator (BPR)                                  | 11 | manifold outlet sensors (temperature, pressure, humidity, etc.) |
| 5 | test manifold  | 12 | line to vent  |
| 6 | manifold inlet sensors (temperature, pressure, humidity, etc.) | 13 | test gases  |
| 7 | reference sensor No. 1   |    |   |

**Figure B.2 — Flow-through test set-up (process flow diagram)**

**B.3 Parallel arrangement**

In this case, sensors are arranged in a parallel configuration (i.e. each of  $X$  sensors gets  $1/X$ th of the overall flow). Accordingly, all sensors are ensured not to have any change in hydrogen volume fraction caused by consumption of hydrogen by upstream sensors.

NOTE It is generally the decision of the test engineer as to whether to use a series or parallel arrangement. The main factors that would affect this decision are as follows:

- overall flow rate of gases;
- hydrogen consumption rate by each individual sensor;
- number of sensors under test;
- presence or absence of reference sensors.

## B.4 Advantages and disadvantages of the flow-through test method

### B.4.1 Advantages

The flow-through test method has the following advantages:

- set-up can be arranged in series or parallel, according to testing requirements;
- can vary and control the following flow properties:
  - pressure (via back-pressure regulator);
  - flow (via mass flow controller);
  - temperature (with standard test station configuration);
  - relative humidity (with standard test station configuration);
  - freeze/thaw (with special test station configuration);
- capable of automation (with standard test station configuration):
  - standardization of testing protocols;
  - robustness and reliability testing (longer time periods);
- ability to simulate flow-through type applications (automotive);
- can test multiple sensors simultaneously;
- allows for various degrees of complexity and integration;
- design is easily adapted from standard fuel cell test station.

### B.4.2 Disadvantages

The flow-through test method has the following disadvantages:

- requires flow (cannot accurately simulate ambient applications);
- requires use of reference sensors (for response time testing);
- it is somewhat difficult to control certain flow properties (i.e. RH).

## Bibliography

- [1] ISO/TR 15916, *Basic considerations for the safety of hydrogen systems*
- [2] ISO/IEC Guide 99:2007, *International vocabulary of metrology — Basic and general concepts and associated terms (VIM)*
- [3] IEC 60050-351, *International Electrotechnical Vocabulary — Part 351: Control technology*
- [4] IEC 60079-1, *Explosive atmospheres — Part 1: Equipment protection by flameproof enclosures “d”*
- [5] IEC 60079-2, *Explosive atmospheres — Part 2: Equipment protection by pressurized enclosures “p”*
- [6] IEC 60079-7, *Explosive atmospheres — Part 7: Equipment protection by increased safety “e”*
- [7] IEC 60079-11, *Explosive atmospheres — Part 11: Equipment protection by intrinsic safety “i”*
- [8] IEC 60079-15, *Explosive atmospheres — Part 15: Equipment protection by type of protection “n”*
- [9] IEC 60079-18, *Explosive atmospheres — Part 18: Equipment protection by encapsulation “m”*
- [10] IEC/TR 60079-20-1, *Explosive atmospheres — Part 20-1: Material characteristics for gas and vapour classification — Test methods and data*
- [11] IEC 60079-29-1, *Explosive atmospheres — Part 29-1: Gas detectors — Performance requirements of detectors for flammable gases*
- [12] IEC 60069-29-2, *Explosive atmospheres — Part 29-2: Gas detectors — Selection, installation, use and maintenance of detectors for flammable gases and oxygen*
- [13] CSA C22.2 No. 152, *Combustible gas detection instruments*
- [14] JIS M 7626, *Stationary type combustible gas alarm*
- [15] JIS M 7653, *Portable type combustible gas detector*
- [16] OIML R 121, *The scale of relative humidity of air certified against saturated salt solutions*
- [17] UL 2075, *Standard for Gas and Vapor Detectors and Sensors*



*This page has been intentionally left blank*

---

## BSI - British Standards Institution

BSI is the independent national body responsible for preparing British Standards. It presents the UK view on standards in Europe and at the international level. It is incorporated by Royal Charter.

### Revisions

British Standards are updated by amendment or revision. Users of British Standards should make sure that they possess the latest amendments or editions.

It is the constant aim of BSI to improve the quality of our products and services. We would be grateful if anyone finding an inaccuracy or ambiguity while using this British Standard would inform the Secretary of the technical committee responsible, the identity of which can be found on the inside front cover. Tel: +44 (0)20 8996 9000. Fax: +44 (0)20 8996 7400.

BSI offers members an individual updating service called PLUS which ensures that subscribers automatically receive the latest editions of standards.

### Buying standards

Orders for all BSI, international and foreign standards publications should be addressed to Customer Services. Tel: +44 (0)20 8996 9001. Fax: +44 (0)20 8996 7001 Email: [orders@bsigroup.com](mailto:orders@bsigroup.com) You may also buy directly using a debit/credit card from the BSI Shop on the Website <http://www.bsigroup.com/shop>

In response to orders for international standards, it is BSI policy to supply the BSI implementation of those that have been published as British Standards, unless otherwise requested.

### Information on standards

BSI provides a wide range of information on national, European and international standards through its Library and its Technical Help to Exporters Service. Various BSI electronic information services are also available which give details on all its products and services. Contact Information Centre. Tel: +44 (0)20 8996 7111 Fax: +44 (0)20 8996 7048 Email: [info@bsigroup.com](mailto:info@bsigroup.com)

Subscribing members of BSI are kept up to date with standards developments and receive substantial discounts on the purchase price of standards. For details of these and other benefits contact Membership Administration. Tel: +44 (0)20 8996 7002 Fax: +44 (0)20 8996 7001 Email: [membership@bsigroup.com](mailto:membership@bsigroup.com)

Information regarding online access to British Standards via British Standards Online can be found at <http://www.bsigroup.com/BSOL>

Further information about BSI is available on the BSI website at <http://www.bsigroup.com>

### Copyright

Copyright subsists in all BSI publications. BSI also holds the copyright, in the UK, of the publications of the international standardization bodies. Except as permitted under the Copyright, Designs and Patents Act 1988 no extract may be reproduced, stored in a retrieval system or transmitted in any form or by any means – electronic, photocopying, recording or otherwise – without prior written permission from BSI.

This does not preclude the free use, in the course of implementing the standard, of necessary details such as symbols, and size, type or grade designations. If these details are to be used for any other purpose than implementation then the prior written permission of BSI must be obtained.

Details and advice can be obtained from the Copyright and Licensing Manager. Tel: +44 (0)20 8996 7070 Email: [copyright@bsigroup.com](mailto:copyright@bsigroup.com)