

# Road vehicles — End-of-life activation of on-board pyrotechnic devices

## Part 4: Additional communication line with bidirectional communication

ICS 43.040.80

## National foreword

This British Standard is the UK implementation of ISO 26021-4:2009.

The UK participation in its preparation was entrusted to Technical Committee AUE/16, Electrical and electronic equipment.

A list of organizations represented on this committee can be obtained on request to its secretary.

This publication does not purport to include all the necessary provisions of a contract. Users are responsible for its correct application.

**Compliance with a British Standard cannot confer immunity from legal obligations.**

This British Standard was published under the authority of the Standards Policy and Strategy Committee on 30 June 2009

© BSI 2009

ISBN 978 0 580 58067 3

### Amendments/corrigenda issued since publication

Date	Comments

---

---

**Road vehicles — End-of-life activation of  
on-board pyrotechnic devices —**

Part 4:  
**Additional communication line with  
bidirectional communication**

*Véhicules routiers — Activation de fin de vie des dispositifs  
pyrotechniques embarqués —*

*Partie 4: Ligne de communication additionnelle avec communication  
bidirectionnelle*



**PDF disclaimer**

This PDF file may contain embedded typefaces. In accordance with Adobe's licensing policy, this file may be printed or viewed but shall not be edited unless the typefaces which are embedded are licensed to and installed on the computer performing the editing. In downloading this file, parties accept therein the responsibility of not infringing Adobe's licensing policy. The ISO Central Secretariat accepts no liability in this area.

Adobe is a trademark of Adobe Systems Incorporated.

Details of the software products used to create this PDF file can be found in the General Info relative to the file; the PDF-creation parameters were optimized for printing. Every care has been taken to ensure that the file is suitable for use by ISO member bodies. In the unlikely event that a problem relating to it is found, please inform the Central Secretariat at the address given below.



**COPYRIGHT PROTECTED DOCUMENT**

© ISO 2009

All rights reserved. Unless otherwise specified, no part of this publication may be reproduced or utilized in any form or by any means, electronic or mechanical, including photocopying and microfilm, without permission in writing from either ISO at the address below or ISO's member body in the country of the requester.

ISO copyright office  
Case postale 56 • CH-1211 Geneva 20  
Tel. + 41 22 749 01 11  
Fax + 41 22 749 09 47  
E-mail [copyright@iso.org](mailto:copyright@iso.org)  
Web [www.iso.org](http://www.iso.org)

Published in Switzerland

## Contents

Page

Foreword.....	iv
Introduction .....	v
1 Scope .....	1
2 Normative references .....	1
3 Terms and definitions, abbreviated terms .....	1
3.1 Terms and definitions.....	1
3.2 Abbreviated terms .....	2
4 Conventions .....	2
5 Pyrotechnic device deployment via on-board diagnostic architecture .....	2
5.1 Vehicle system description .....	2
5.2 Example of in-vehicle hardware and software provision .....	3
5.3 Additional communication line .....	3
6 ACL with bidirectional specification (Hardware description) .....	4
6.1 Connection to the vehicle .....	4
6.2 Physical layer .....	4
7 Deployment process with ACL and bidirectional communication .....	5
7.1 Deployment process – overview .....	5
7.2 Data link layer.....	5
7.3 ACL step 1 – request deployment sequence .....	7
7.4 ACL step 2 – deployment confirmation sequence .....	9
7.5 ACL step 3 – deployment termination sequence .....	9
7.6 Summary of data byte format transmitted during ACL steps 1, 2 and 3.....	10
Bibliography .....	11

## Foreword

ISO (the International Organization for Standardization) is a worldwide federation of national standards bodies (ISO member bodies). The work of preparing International Standards is normally carried out through ISO technical committees. Each member body interested in a subject for which a technical committee has been established has the right to be represented on that committee. International organizations, governmental and non-governmental, in liaison with ISO, also take part in the work. ISO collaborates closely with the International Electrotechnical Commission (IEC) on all matters of electrotechnical standardization.

International Standards are drafted in accordance with the rules given in the ISO/IEC Directives, Part 2.

The main task of technical committees is to prepare International Standards. Draft International Standards adopted by the technical committees are circulated to the member bodies for voting. Publication as an International Standard requires approval by at least 75 % of the member bodies casting a vote.

Attention is drawn to the possibility that some of the elements of this document may be the subject of patent rights. ISO shall not be held responsible for identifying any or all such patent rights.

ISO 26021-4 was prepared by Technical Committee ISO/TC 22, *Road vehicles*, Subcommittee SC 3, *Electrical and electronic equipment*.

ISO 26021 consists of the following parts, under the general title *Road vehicles — End-of-life activation of on-board pyrotechnic devices*:

- *Part 1: General information and use case definitions*
- *Part 2: Communication requirements*
- *Part 3: Tool requirements*
- *Part 4: Additional communication line with bidirectional communication*
- *Part 5: Additional communication line with pulse width modulated signal*

## Introduction

Worldwide, nearly all new vehicles are equipped with one or more safety systems. This can include advanced protection systems based on pyrotechnic actuators. All components which contain pyrotechnic substances can be handled in the same way.

Recycling these vehicles demands a new process to ensure that the deactivation of airbags is safe and cost-efficient. Due to the harmonization of the on-board diagnostic (OBD) interface, there is a possibility of using it for on-board deployment, which is based on the same tools and processes.

Representatives of the global automobile industry agreed that automobile manufacturers

- do not support reuse as an appropriate treatment method for pyrotechnic devices,
- believe treatment of pyrotechnic devices is required before shredding, and
- support in-vehicle deployment as the preferred method.

Based on this agreement, the four big associations of automobile manufacturers (ACEA, Alliance, JAMA and KAMA) started to develop a method for the “in-vehicle deployment of pyrotechnic components in cars with the pyrotechnic device deployment tool (PDT)”. The objective is that in the future a dismantler will use only one tool without any accessories to deploy all pyrotechnic devices inside an end-of-life vehicle (ELV) by using an existing interface to the car.

Because of different requirements and safety concepts an additional communication line (ACL) is added to the basic CAN communication method. In this part of ISO 26021 ACL is used to mean an additional communication line with bidirectional communication. This bidirectional communication is used for systems with a specific concept that the initiation requires ECU acknowledgement.





# Road vehicles — End-of-life activation of on-board pyrotechnic devices —

## Part 4: Additional communication line with bidirectional communication

### 1 Scope

This part of ISO 26021 defines the requirements of redundancy hardware or software systems independent from the controller area network (CAN) line, which are activated by the additional communication line (ACL hardware line).

It also describes the additional sequences of the deployment process, and the technical details for the direct hardware connection between the pyrotechnic device deployment tool (PDT) and the pyrotechnic control unit (PCU).

### 2 Normative references

The following referenced documents are indispensable for the application of this document. For dated references, only the edition cited applies. For undated references, the latest edition of the referenced document (including any amendments) applies.

ISO 14230-1, *Road vehicles — Diagnostic Systems — Keyword Protocol 2000 — Part 1: Physical layer*

ISO 15031-3, *Road vehicles — Communication between vehicle and external equipment for emissions-related diagnostics — Part 3: Diagnostic connector and related electrical circuits, specification and use*

ISO 15765-3, *Road vehicles — Diagnostics on Controller Area Networks (CAN) — Part 3: Implementation of unified diagnostic services (UDS on CAN)*

ISO 15765-4, *Road vehicles — Diagnostics on Controller Area Networks (CAN) — Part 4: Requirements for emissions-related systems*

ISO 26021-1, *Road Vehicles — End-of-life activation of on-board pyrotechnic devices — Part 1: General information and use case definitions*

ISO 26021-2, *Road Vehicles — End-of-life activation of on-board pyrotechnic devices — Part 2: Communication requirements*

ISO 26021-3, *Road Vehicles — End-of-life activation of on-board pyrotechnic devices — Part 3: Tool requirements*

### 3 Terms and definitions, abbreviated terms

#### 3.1 Terms and definitions

For the purposes of this document, the terms and definitions given in ISO 14230-1, ISO 15031-3, ISO 15765-3, ISO 15765-4, ISO 26021-1, ISO 26021-2 and ISO 26021-3 apply.

**3.2 Abbreviated terms**

- ACL additional communication line
- PDT pyrotechnic device deployment tool
- PCU pyrotechnic control unit
- OBD on-board diagnostic
- OSI open systems interconnection

**4 Conventions**

This International Standard is based on the conventions discussed in the OSI service conventions (ISO/IEC 10731) as they apply for diagnostic services.

**5 Pyrotechnic device deployment via on-board diagnostic architecture**

**5.1 Vehicle system description**

This International Standard is based on an envisaged diagnostic network architecture in combination with the PCU deployment architecture, as described in this subclause.

ISO 26021-2 defines the mandatory vehicle interface of the PCU and PDT. The PCU is connected with the vehicle diagnostic connector and the communication specifications comply with ISO 15765-3 and ISO 15765-4. The PDT communicates with the PCU on CAN\_H and CAN\_L and enables deployment with bidirectional communication.

Depending upon the vehicle-specific architecture, the mandatory link of the PCU may be connected via a gateway to the OBD connector (see Figure 1), thus a CAN interface in the PCU for the mandatory link may not be required.

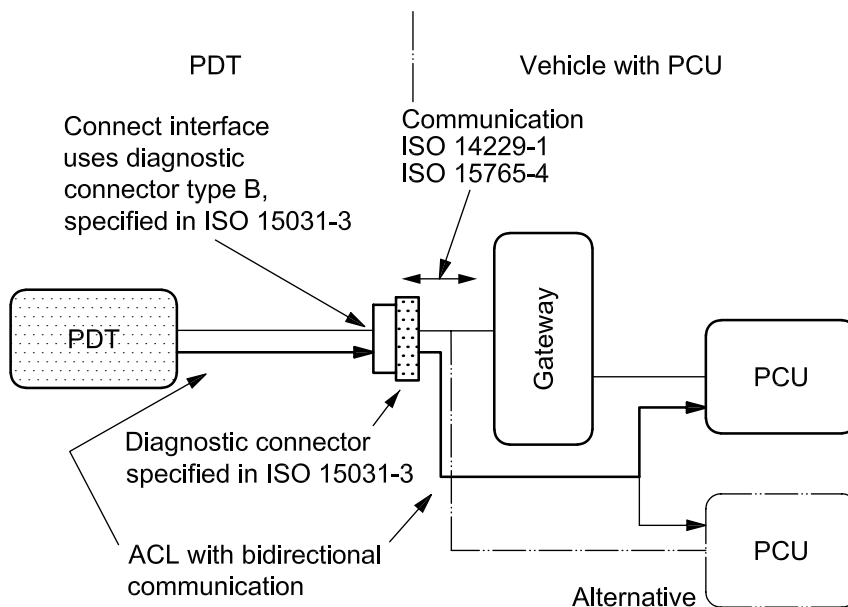

**Figure 1 — Access to the vehicle via diagnostic connector**

## 5.2 Example of in-vehicle hardware and software provision

To execute the on-board deployment via the OBD link, the PCU software shall have full access to the output driver stage, which controls the deployment loops. To achieve this, the saving path is controlled via the ACL with a bidirectional signal (see Figure 2).

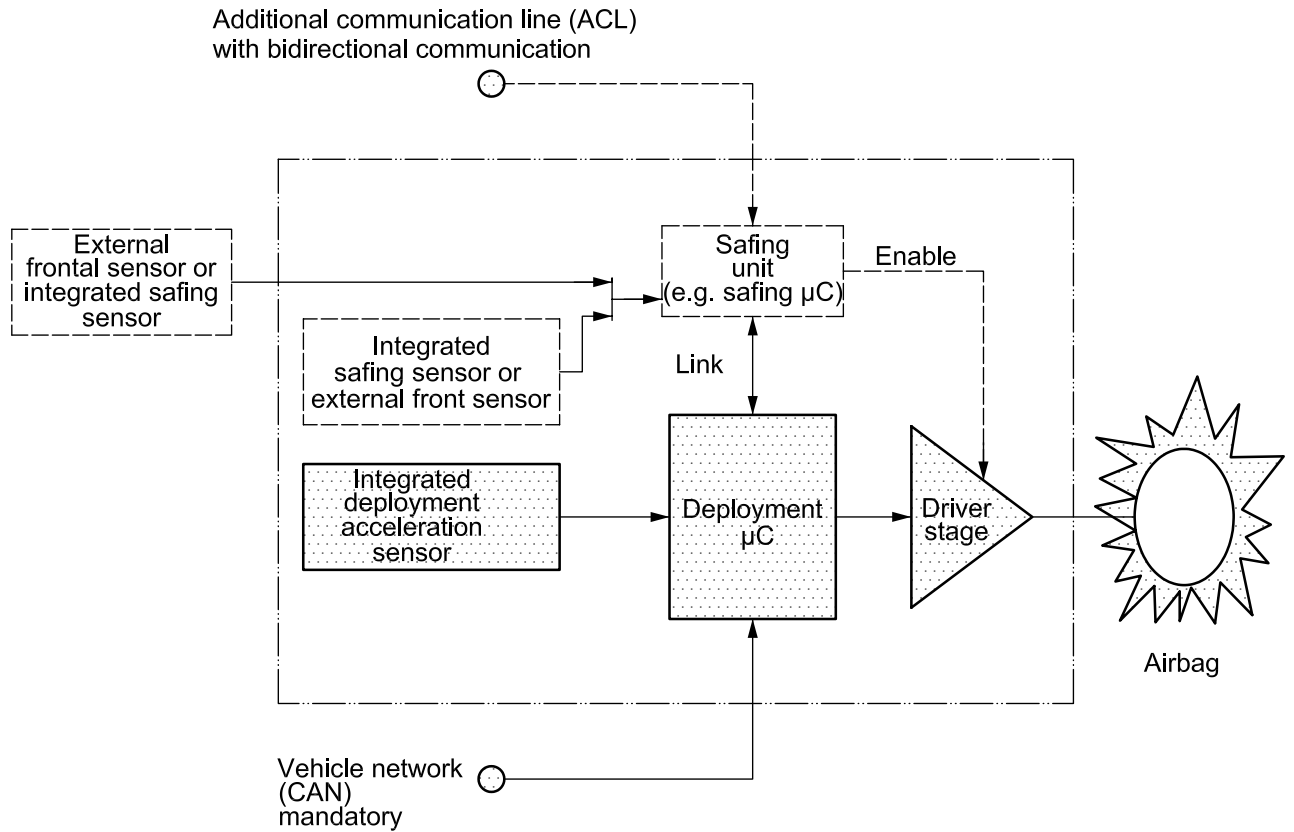

**Figure 2 — Overview of hardware and software provision**

## 5.3 Additional communication line

Depending on the hardware architecture of the PCU an additional signal is used. General requirements for the interface between deployment sequence and ACL sequence are given in Clauses 6 and 7.

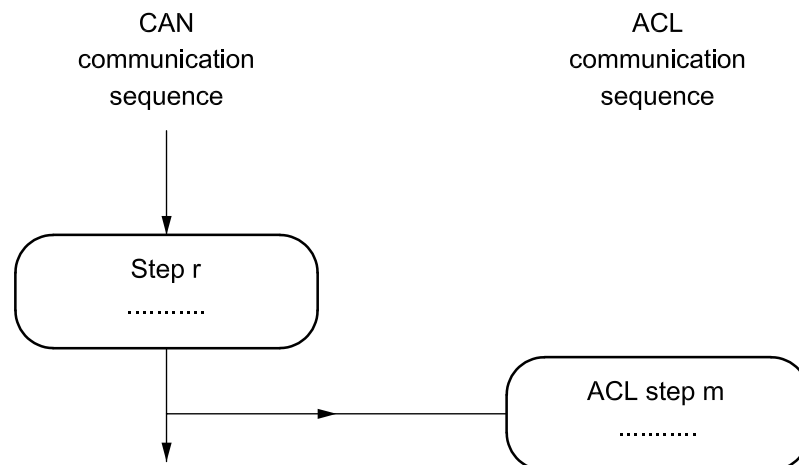

**Figure 3 — Integration of ACL communication into deployment process**

The standardized steps specify the diagnostic sequence. The ACL communication step m is the specified place to enable the hardware saving possibility.

## 6 ACL with bidirectional specification (Hardware description)

### 6.1 Connection to the vehicle

The connection to the vehicle shall be made using the connector specified in ISO 15031-3. Table 1 shows the contact allocation according to ISO 15031-3 and additional communication line is assigned to contact 15.

**Table 1 — Contact allocation of diagnostic connector**

Contact	General allocation
1	Discretionary
2	Bus positive line of SAE J1850
3	Discretionary
4	Chassis ground
5	Signal ground
6	CAN_H line of ISO 15765-4
7	K line of ISO 9141-2 and ISO 14230-4
8	Discretionary
9	Discretionary
10	Bus negative line of SAE J1850
11	Discretionary
12	Discretionary
13	Discretionary
14	CAN_L line of ISO 15765-4
15	L line of ISO 9141-2 and ISO 14230-4, ACL (optional)
16	Permanent positive voltage

### 6.2 Physical layer

The physical layer of ACL with bidirectional communication shall be compliant with ISO 14230-1 and the details are shown in Figure 4. (Values for 24 V systems appear in parentheses.)

If no ACL is supported, the line shall be held as high impedance for safety aspects. Therefore, the PCU cannot receive the L-line signal for diagnostic purposes, even if the legacy scan tool applicable with ISO 14230-1 is connected to the PCU and, as a result, there is no influence on any scan tool in the field.

During Sys-Init and documentation process, the battery voltage value is read (see ISO 26021-2:2008, 8.4.2). The appropriate pull up resistor is chosen according to the battery voltage value.

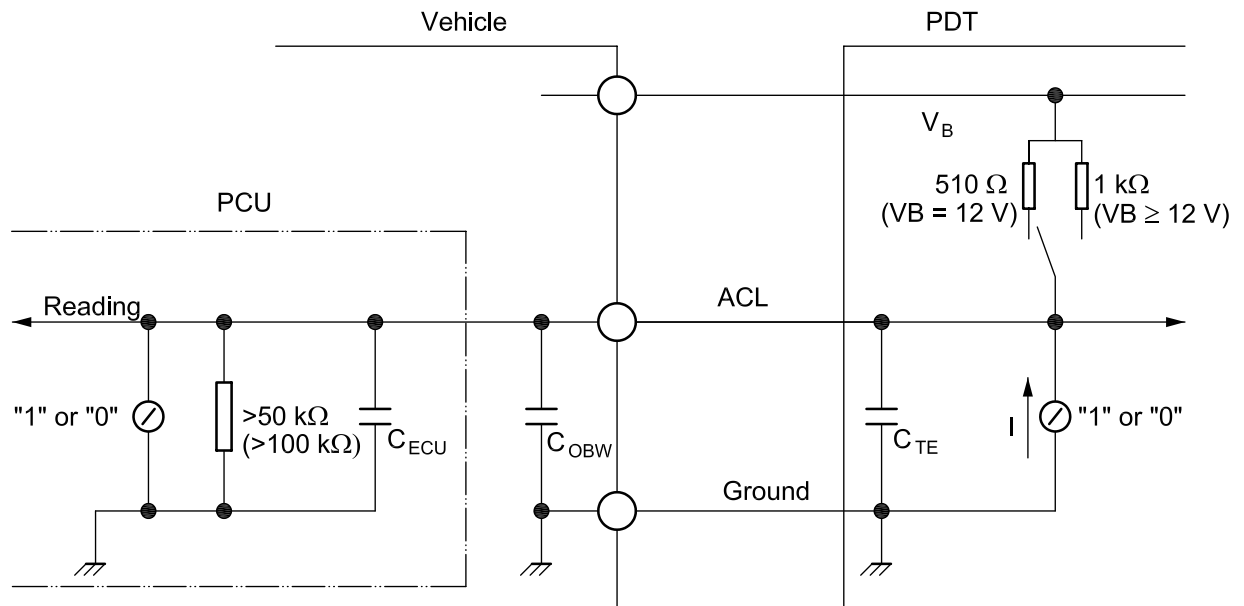

**Figure 4 — Physical layer of ACL with bidirectional communication**

## 7 Deployment process with ACL and bidirectional communication

### 7.1 Deployment process – overview

After the PDT detects the PCU (connector C) the PDT continues the following steps to perform the deployment process. The main focuses in this document are the additional steps of ACL preparation and ACL steps 1 to 3.

See ISO 26021-2 for detailed information on standardized steps.

#### a) ACL-Init

ACL optional information is obtained by the ACL preparation process. The PDT shall skip ACL step 1 and proceed to connector (F) directly, if no ACL is selected. (Also ACL steps 2 and 3 shall be skipped.) If the ACL option is selected, the ACL option information specific to each PCU can be obtained in ACL step 1.

#### b) Device deployment

Before scrapping each device, ACL step 2 shall be executed for confirmation.

#### c) Deployment termination of one PCU

ACL step 3 shall be executed and the deployment of all devices controlled by the specific PCU is terminated. If there is more than one PCU, PDT shall proceed to connector (D) and the same process will be executed until all PCUs are terminated.

### 7.2 Data link layer

ACL steps 1 to 3 with bidirectional communication, as shown in Figure 5, is originally prepared for airbag deployment and the details are shown in Figures 7 to 10. Figure 6 shows the byte format for bidirectional communication; the communication protocol is asynchronous communication without error check. Although the communication baud rate is 10 400 Bd, it does not include the header, service identifier and check sum byte.

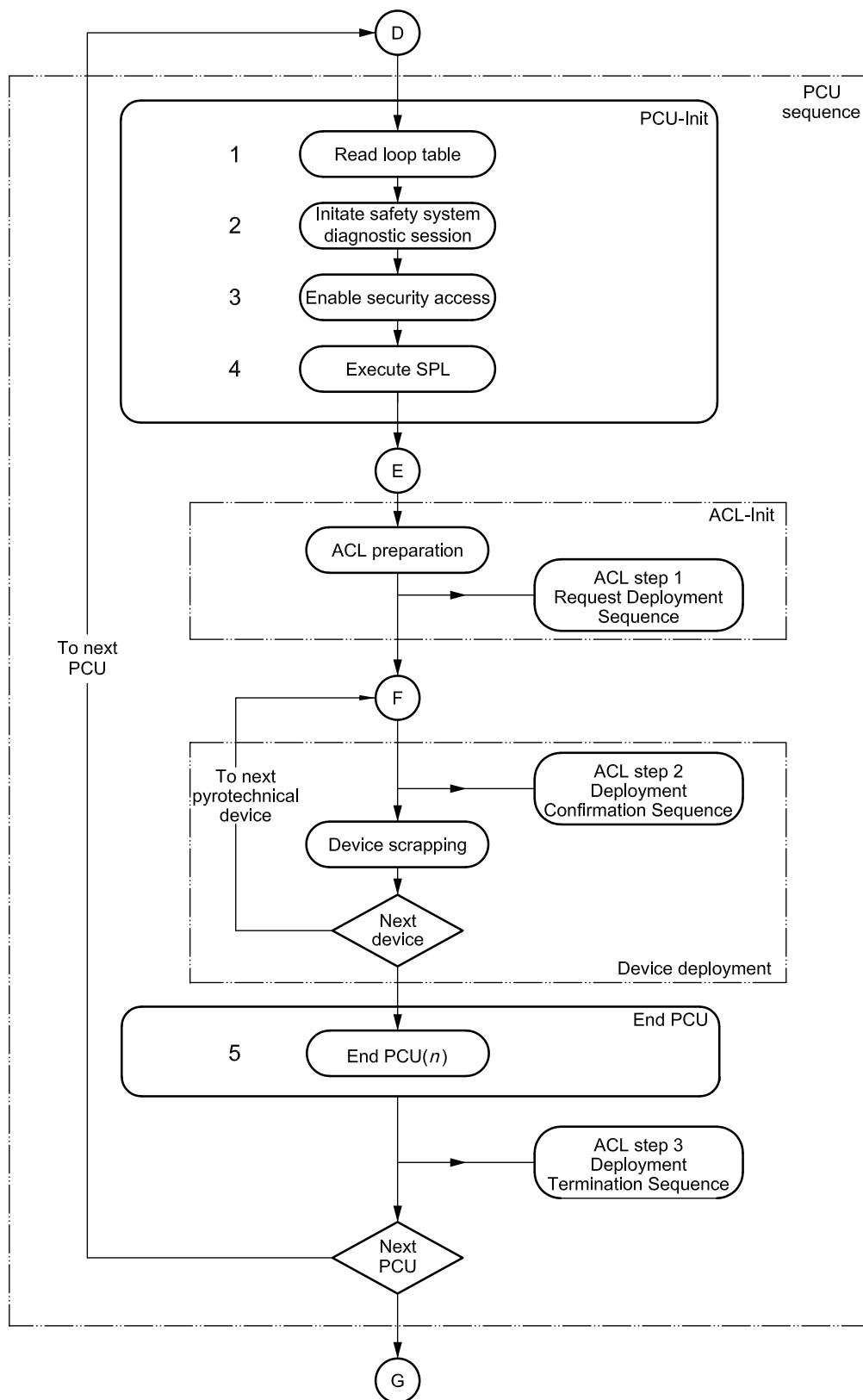
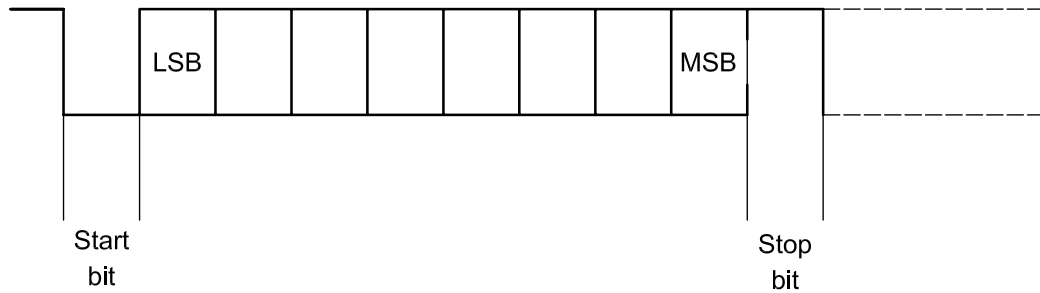

Figure 5 — Deployment process PCU sequence



**Figure 6 — Byte format of bidirectional communication ACL**

### 7.3 ACL step 1 – request deployment sequence

#### 7.3.1 Switching the pull up resistor in PDT

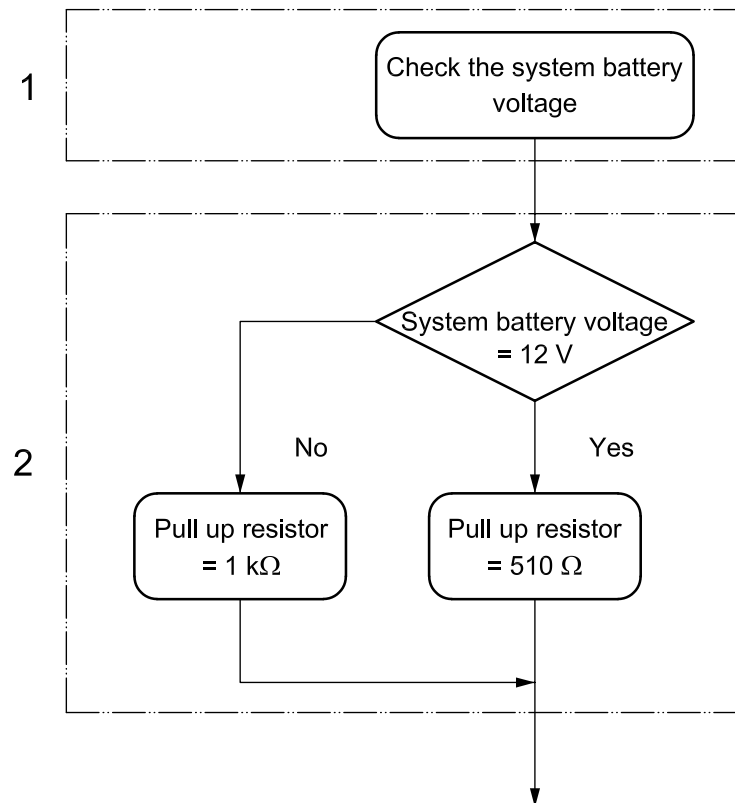

**Key**

- 1 PDT obtains the system battery voltage value information by Data Identifier 0x FA 06. (See ISO 26021-2, Table A.6.)
- 2 ISO 14230-1 defines two types of pull up resistors for the diagnostic tester according to the system battery voltage, i.e. 510 Ω for 12 V systems and 1 kΩ for 24 V systems. Therefore, the PDT selects the appropriate internal pull up resistor according to the system battery voltage value information.

**Figure 7 — Switching the pull up resistor**

7.3.2 Communication between the PDT and the PCU

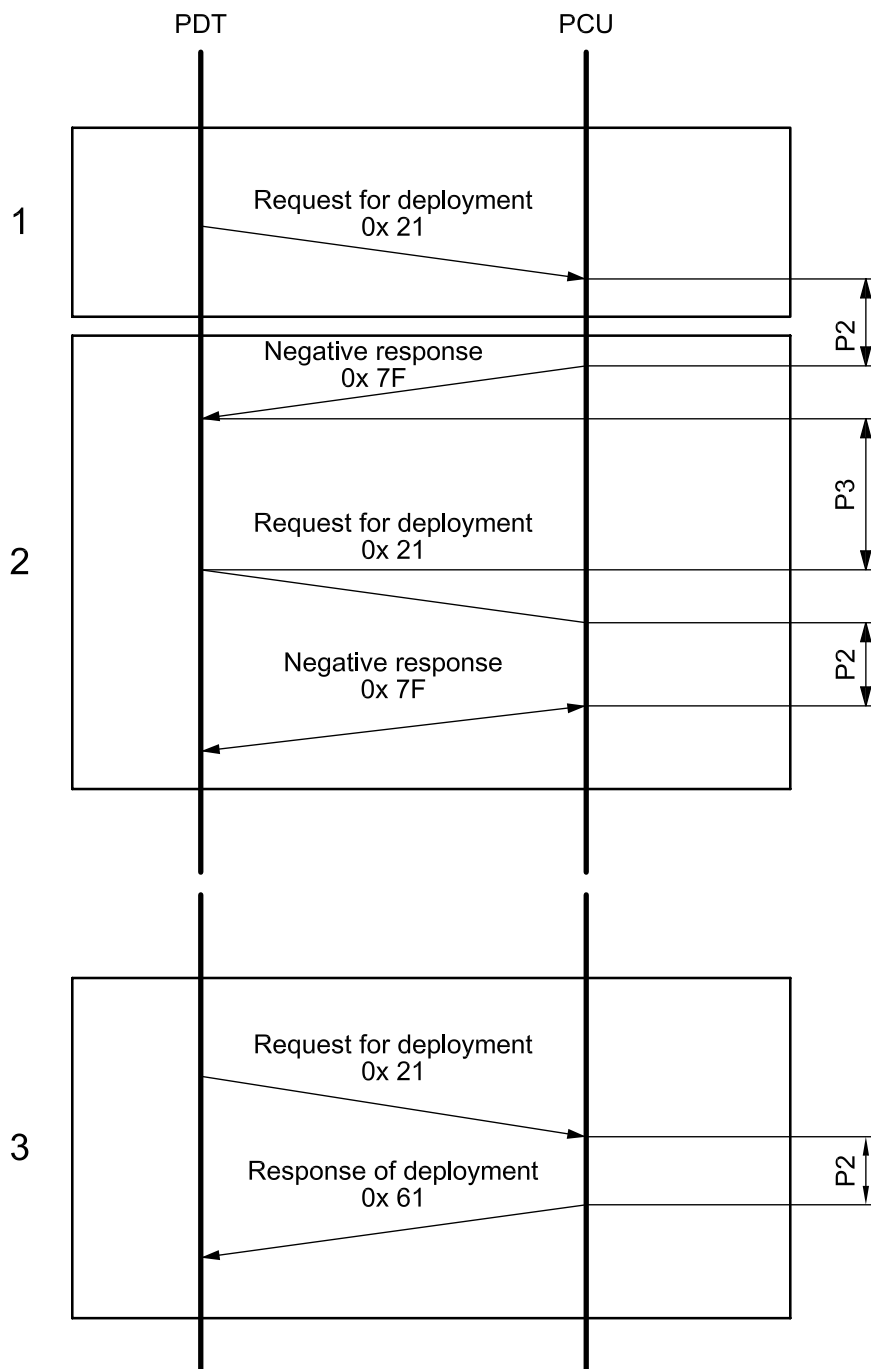

Key

- 1 The PDT sends request for deployment data to the PCU.
- 2 Case 1. If the PCU replies negative response when the PCU can't proceed to the activation process due to some reasons, the PDT will send request for deployment data to the PCU automatically. After three negative responses, the PDT will abort the deployment process and proceed to connector (End) of Figure 5.
- 3 Case 2. If the PDT receives no reply from the PCU for 15 s, the PDT will abort the deployment process and proceed to connector (End) of Figure 5.
- 4 Case 3. If the PDT receives response of deployment from the PCU, the PDT proceeds to connector (E) of Figure 5.

Figure 8 — ACL Step 1 sequence Request Deployment Sequence



#### 7.4 ACL step 2 – deployment confirmation sequence

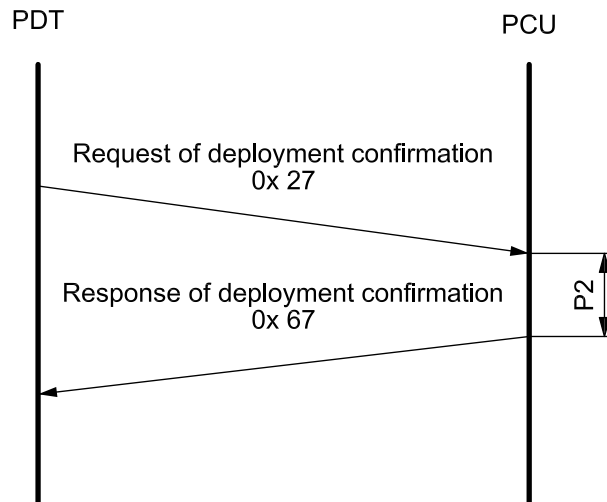
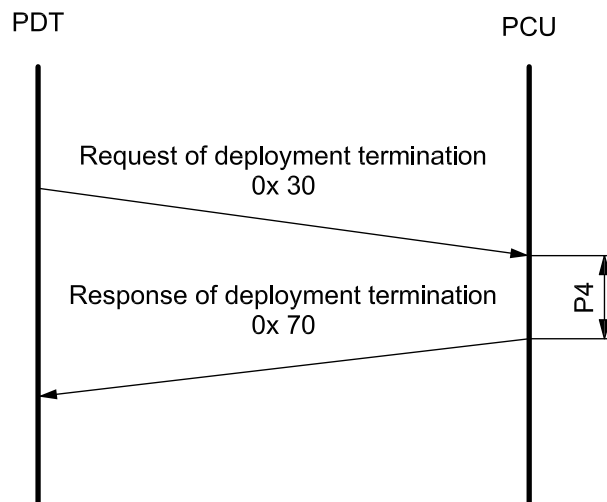

**Figure 9 — ACL step 2 sequence: deployment confirmation sequence**

The PDT sends the request for deployment confirmation, asking the PCU to ensure that the technician has a clear intention to deploy.

The PCU replies by sending a response of deployment confirmation and the PDT proceeds to connector (5), see Figure 5.

#### 7.5 ACL step 3 – deployment termination sequence



**Figure 10 –ACL step 3 sequence: deployment termination sequence**

After all the PCU's deployments are completed, the PDT sends the request for deployment termination and the PCU replies by sending a response of deployment termination.

The PDT then proceeds to connector (G), see Figure 5.

## 7.6 Summary of data byte format transmitted during ACL steps 1, 2 and 3

### 7.6.1 Transmitted data byte

Transmitted data bytes during ACL steps 1, 2 and 3 are summarized in Table 2.

**Table 2 — Transmitted data byte**

	Deployment	Deployment confirmation	Deployment termination	Negative response
Request	0x 21	0x 27	0x 30	—
Response	0x 61	0x 67	0x 70	0x 7F

NOTE Although not technically important, deployment confirmation data corresponds to security access SI value and wait data corresponds to negative response SI value given in ISO 14229-1.

### 7.6.2 P2, P3 and P4 timing requirements

P2, P3 and P4 timing requirements are shown in Table 3.

**Table 3 — P2, P3 and P4 timing requirements**

Timing parameter	P2	P3	P4
Duration	1 ms to 50 ms	1 ms to 100 ms	1 ms to 1 000 ms

## Bibliography

- [1] ISO 9141, *Road vehicles — Diagnostic systems — Requirements for interchange of digital information*
- [2] ISO 9141-2, *Road vehicles — Diagnostic systems — Part 2: CARB requirements for interchange of digital information*
- [3] ISO/IEC 10731, *Information technology — Open Systems Interconnection — Basic Reference Model — Conventions for the definition of OSI services*
- [4] ISO 14229-1, *Road vehicles — Unified diagnostic services (UDS) — Part 1: Specification and requirements*
- [5] ISO 14230-4, *Road vehicles — Diagnostic systems — Keyword Protocol 2000 — Part 4: Requirements for emission-related systems*
- [6] SAE J1850, *Class B Data Communications Network Interface*





---

## BSI - British Standards Institution

BSI is the independent national body responsible for preparing British Standards. It presents the UK view on standards in Europe and at the international level. It is incorporated by Royal Charter.

### Revisions

British Standards are updated by amendment or revision. Users of British Standards should make sure that they possess the latest amendments or editions.

It is the constant aim of BSI to improve the quality of our products and services. We would be grateful if anyone finding an inaccuracy or ambiguity while using this British Standard would inform the Secretary of the technical committee responsible, the identity of which can be found on the inside front cover. Tel: +44 (0)20 8996 9000. Fax: +44 (0)20 8996 7400.

BSI offers members an individual updating service called PLUS which ensures that subscribers automatically receive the latest editions of standards.

### Buying standards

Orders for all BSI, international and foreign standards publications should be addressed to Customer Services. Tel: +44 (0)20 8996 9001. Fax: +44 (0)20 8996 7001 Email: [orders@bsigroup.com](mailto:orders@bsigroup.com) You may also buy directly using a debit/credit card from the BSI Shop on the Website <http://www.bsigroup.com/shop>

In response to orders for international standards, it is BSI policy to supply the BSI implementation of those that have been published as British Standards, unless otherwise requested.

### Information on standards

BSI provides a wide range of information on national, European and international standards through its Library and its Technical Help to Exporters Service. Various BSI electronic information services are also available which give details on all its products and services. Contact Information Centre. Tel: +44 (0)20 8996 7111 Fax: +44 (0)20 8996 7048 Email: [info@bsigroup.com](mailto:info@bsigroup.com)

Subscribing members of BSI are kept up to date with standards developments and receive substantial discounts on the purchase price of standards. For details of these and other benefits contact Membership Administration. Tel: +44 (0)20 8996 7002 Fax: +44 (0)20 8996 7001 Email: [membership@bsigroup.com](mailto:membership@bsigroup.com)

Information regarding online access to British Standards via British Standards Online can be found at <http://www.bsigroup.com/BSOL>

Further information about BSI is available on the BSI website at <http://www.bsigroup.com>

### Copyright

Copyright subsists in all BSI publications. BSI also holds the copyright, in the UK, of the publications of the international standardization bodies. Except as permitted under the Copyright, Designs and Patents Act 1988 no extract may be reproduced, stored in a retrieval system or transmitted in any form or by any means – electronic, photocopying, recording or otherwise – without prior written permission from BSI.

This does not preclude the free use, in the course of implementing the standard, of necessary details such as symbols, and size, type or grade designations. If these details are to be used for any other purpose than implementation then the prior written permission of BSI must be obtained.

Details and advice can be obtained from the Copyright and Licensing Manager. Tel: +44 (0)20 8996 7070 Email: [copyright@bsigroup.com](mailto:copyright@bsigroup.com)