

# Gas cylinders — Operational procedures for the safe removal of valves from gas cylinders

ICS 23.020.30

## National foreword

This British Standard is the UK implementation of ISO 25760:2009.

The UK participation in its preparation was entrusted to Technical Committee PVE/3/7, Gas cylinder (receptacle) operations.

A list of organizations represented on this committee can be obtained on request to its secretary.

This publication does not purport to include all the necessary provisions of a contract. Users are responsible for its correct application.

**Compliance with a British Standard cannot confer immunity from legal obligations.**

This British Standard was published under the authority of the Standards Policy and Strategy Committee on 31 July 2009

© BSI 2009

ISBN 978 0 580 57712 3

### Amendments/corrigenda issued since publication

Date	Comments

# INTERNATIONAL STANDARD

**ISO**  
**25760**

First edition  
2009-06-15

---

---

## **Gas cylinders — Operational procedures for the safe removal of valves from gas cylinders**

*Bouteilles à gaz — Modes opératoires de dépose en toute sécurité des  
robinets de bouteilles à gaz*



Reference number  
ISO 25760:2009(E)

**PDF disclaimer**

This PDF file may contain embedded typefaces. In accordance with Adobe's licensing policy, this file may be printed or viewed but shall not be edited unless the typefaces which are embedded are licensed to and installed on the computer performing the editing. In downloading this file, parties accept therein the responsibility of not infringing Adobe's licensing policy. The ISO Central Secretariat accepts no liability in this area.

Adobe is a trademark of Adobe Systems Incorporated.

Details of the software products used to create this PDF file can be found in the General Info relative to the file; the PDF-creation parameters were optimized for printing. Every care has been taken to ensure that the file is suitable for use by ISO member bodies. In the unlikely event that a problem relating to it is found, please inform the Central Secretariat at the address given below.



**COPYRIGHT PROTECTED DOCUMENT**

© ISO 2009

All rights reserved. Unless otherwise specified, no part of this publication may be reproduced or utilized in any form or by any means, electronic or mechanical, including photocopying and microfilm, without permission in writing from either ISO at the address below or ISO's member body in the country of the requester.

ISO copyright office  
Case postale 56 • CH-1211 Geneva 20  
Tel. + 41 22 749 01 11  
Fax + 41 22 749 09 47  
E-mail [copyright@iso.org](mailto:copyright@iso.org)  
Web [www.iso.org](http://www.iso.org)

Published in Switzerland

## Contents

Page

Foreword.....	iv
Introduction .....	v
1 Scope .....	1
2 Normative references .....	1
3 Terms and definitions.....	1
4 General requirements.....	3
4.1 Application .....	3
4.2 Hazards .....	3
4.3 Operator safety and protection .....	3
4.4 Operator qualifications.....	3
4.5 Operator errors .....	4
4.6 Special valve designs.....	5
5 Methods for inoperable valves .....	5
5.1 Summary of methods .....	5
5.2 Choice of method.....	6
6 Procedures .....	6
6.1 Procedures to identify and segregate cylinders with inoperable valves.....	6
6.2 Standard devalving procedure for treating cylinders with operable valves.....	7
6.3 Procedures for treating cylinders with inoperable valves.....	8
7 Damaged valves and cylinders .....	8
Annex A (informative) Reasons cylinder valves become inoperable .....	9
Annex B (informative) Examples of methods for depressurization of gas cylinders with inoperable valves .....	11
Bibliography .....	18

## Foreword

ISO (the International Organization for Standardization) is a worldwide federation of national standards bodies (ISO member bodies). The work of preparing International Standards is normally carried out through ISO technical committees. Each member body interested in a subject for which a technical committee has been established has the right to be represented on that committee. International organizations, governmental and non-governmental, in liaison with ISO, also take part in the work. ISO collaborates closely with the International Electrotechnical Commission (IEC) on all matters of electrotechnical standardization.

International Standards are drafted in accordance with the rules given in the ISO/IEC Directives, Part 2.

The main task of technical committees is to prepare International Standards. Draft International Standards adopted by the technical committees are circulated to the member bodies for voting. Publication as an International Standard requires approval by at least 75 % of the member bodies casting a vote.

Attention is drawn to the possibility that some of the elements of this document may be the subject of patent rights. ISO shall not be held responsible for identifying any or all such patent rights.

ISO 25760 was prepared by Technical Committee ISO/TC 58, *Gas cylinders*, Subcommittee SC 4, *Operational requirements for gas cylinders* and is based on EIGA Document 129/05 *Pressure receptacles with blocked or inoperable valves*. EIGA has granted permission to reproduce excerpts from their document.

## Introduction

Cylinders are devalved for many purposes, such as periodic inspection and testing, cylinder cleaning, change of service, replacement of a damaged valve, installation of a new valve, preparation for filling or scrapping.

Occasionally, gas cylinder valves can become blocked by corrosion or foreign material or become inoperable due to external or internal damage. It is an essential safety requirement that such valved cylinders be identified and treated with special care as soon as practicable. The operation of removing a valve should only be carried out if the cylinder is made safe with respect to residual gas and pressure. It is recommended that gas suppliers be prepared with both the proper equipment and trained operators for dealing with such valved cylinders. Practical techniques that have been tried and tested over many years within the gas industry are described.

Valve removal activities can pose hazards to the life and physical safety of the operator, especially if the cylinder is under pressure.

Valves should only be removed after ensuring there is no residual pressure in the cylinder.





# Gas cylinders — Operational procedures for the safe removal of valves from gas cylinders

## 1 Scope

This International Standard is intended for suppliers, operators in testing facilities, operators performing cylinder maintenance and any person authorized to remove valves from gas cylinders. It details procedures for the safe removal of valves from cylinders and includes techniques for the identification of inoperable valves.

Only the risks due to gas and gas mixtures under pressure are addressed; other technical issues relating to the removal of a valve from a cylinder are not covered.

Some specialized equipment and procedures are in use in parts of the gas industry to safely remove cylinder valves from low pressure gas cylinders while under pressure, e.g. liquefied petroleum gas (LPG); these techniques are not included in this International Standard.

## 2 Normative references

The following referenced documents are indispensable for the application of this document. For dated references, only the edition cited applies. For undated references, the latest edition of the referenced document (including any amendments) applies.

ISO 11114-1, *Transportable gas cylinders — Compatibility of cylinder and valve materials with gas contents — Part 1: Metallic materials*

ISO 11114-2, *Transportable gas cylinders — Compatibility of cylinder and valve materials with gas contents — Part 2: Non-metallic materials*

## 3 Terms and definitions

For the purposes of this document, the following terms and definitions apply:

### 3.1

#### **gas cylinder**

pressure receptacle including individual cylinder, tube, pressure drum or manifold combination of these

### 3.2

#### **valve**

device that allows gas to enter or exit a gas cylinder and retains the pressure in the cylinder when in the closed position

NOTE This also includes the fittings of cylinders in bundles and battery vehicles.

### 3.3

#### **inoperable valve**

valve that is blocked, broken or malfunctioning or that in any way prevents gas from entering or exiting the gas cylinder

NOTE See Annex A.

- 3.4**  
**operable valve**  
device that allows gas to enter or exit a gas cylinder
- 3.5**  
**residual pressure valve**  
RPV  
type of valve that prevents the gas cylinder from being totally depressurized by holding back a specific amount of residual pressure

NOTE 1 Requirements for this type of valve are specified in ISO 15996.

NOTE 2 This valve type is very often associated with a non-return function.

- 3.6**  
**valve with integrated pressure regulator**  
VIPR  
device intended to be permanently fitted to a gas cylinder connection and comprising a shut-off valve system and pressure reduction system

NOTE 1 Adapted from ISO 22435:2007, definition 3.3.

NOTE 2 Requirements for this type of valve are specified in ISO 15996.

- 3.7**  
**pressure relief device**  
PRD  
device that is fitted to the cylinder or cylinder valve and designed to relieve gas pressure in the event of abnormal conditions resulting in the development of excessive pressure inside the cylinder or when the cylinder is subjected to high temperatures

NOTE 1 This might be a pressure relief valve, a non-reclosing PRD or a non-reclosing PRD in combination with a pressure relief valve.

NOTE 2 The expression “pressure relief” is synonymous with “safety relief”, as used in various applicable regulations, codes, standards or specifications.

- 3.8**  
**quick connect valve**  
clip-on valve  
valve that does not contain an operating device, such as a handwheel

- 3.9**  
**low pressure gas cylinder**  
gas cylinder with test pressures no higher than 60 bar<sup>1)</sup>

- 3.10**  
**compressed gas**  
gas which, when packaged under pressure for transport, is entirely gaseous at all temperatures above –50 °C

NOTE This category includes all gases with a critical temperature less than or equal to –50 °C.

---

1) 1 bar = 100 kPa (exactly)

## 4 General requirements

### 4.1 Application

This clause gives general information to be considered. Clause 5 gives a choice of methods for inoperable valves. Procedures to be followed are given in Clause 6.

### 4.2 Hazards

Especially if the cylinder is under pressure, valve removal methods pose certain hazards to the operator, such as:

- stored energy from residual pressure (particularly important if the cylinder is not in a vertical position);
  - residual gas hazards, including
    - fire resulting from flammable gas ignitions
- NOTE Oxidizing gases in the presence of contamination can also cause severe ignition.
- asphyxiation,
  - oxidation,
  - toxicity/corrosivity,
  - projection of pieces under pressure,
  - cold burns due to vaporization of liquefied gases; and
- operating devalving machinery and equipment, such as pinch points, rotation and powered machines.

### 4.3 Operator safety and protection

When an operator is removing a blocked or inoperable valve, other individuals should be on site and able to respond in case of an emergency.

A risk assessment shall be performed in order to avoid the exposure of the operator and other persons who could be affected by hazards. The minimum hazards to take into account for this risk analysis are listed in 4.2.

After the risk assessment is completed, risks shall be eliminated or minimized as far as reasonably practicable by engineering or process changes, such as shields or bunkers. The required or appropriate personnel protective equipment shall be chosen.

### 4.4 Operator qualifications

#### 4.4.1 General

All operators shall have

- appropriate training,
- understanding of the cylinder content, when known, and the precautions which might be necessary to prevent the release or exposure to the gas (see 4.2, 4.3 and 5.2), and
- good practical understanding of the cylinder valve and the method of fitment to the cylinder.

#### 4.4.2 Specific process qualifications

Due to additional hazards that are present, operators shall receive specific training for the processes outlined in this International Standard.

Such processes can include

- the pressure check,
- the devalving process,
- the inoperable valve process.

Proper precautions shall be taken in the work area to protect operators from gas and particle discharges.

Appropriate personal protection equipment shall be worn, and emergency equipment shall be readily available.

Personal protection during devalving shall be adopted according to the hazards that may be present, such as those indicated in 4.2.

#### 4.5 Operator errors

As a minimum, the following possibilities shall be considered in the context of operator errors.

- Incorrectly assuming that a cylinder has no pressure (e.g. placing valved cylinders that have been checked with valved cylinders that have not been checked).
- Incorrectly assuming that a cylinder has been checked for pressure (e.g. devalving more than one cylinder at the same time could lead to this error).
- Incorrectly assuming that a cylinder is empty of a liquefied gas, based upon the marked tare weight.
- Incorrectly assuming that a cylinder with a valve in the open position is no longer under pressure and proceeding to remove the valve.

NOTE The primary risk in this situation is the possibility that the valve is broken or blocked, although the valve appears to be in the open position and the cylinder is still under pressure.

- Relying on a pressure gauge (the operator might incorrectly assume, due to a malfunctioning pressure gauge, that there is no or little pressure in the cylinder). Such malfunction can occur if gauges are
  - obstructed,
  - broken,
  - damaged,
  - out of calibration,
  - designed for only high pressure measurements, or
  - otherwise defective.

## 4.6 Special valve designs

### 4.6.1 Valves (e.g. RPV, VIPR) with residual pressure device

All valves with a residual pressure device have a particular risk that the residual pressure has not been discharged before devalving. It is for this reason that the residual pressure from cylinders equipped with such a device shall be safely discharged using the appropriate equipment. If the device is unknown or if the operator is unsure, obtain information from a knowledgeable source.

### 4.6.2 Quick connect valves (clip-on valve)

Cylinders equipped with such valves shall be safely discharged by using appropriate equipment to release the pressure before being devalved.

### 4.6.3 Other valves

Valves with a special operating mechanism, such as

- valves without handwheels,
- internal valves (inside the cylinder), and
- solenoid operated valves

need special handling.

## 5 Methods for inoperable valves

### 5.1 Summary of methods

There are several methods to release the pressure from a cylinder with an inoperable valve. Some methods are as follows.

- Careful loosening or removal of the cylinder valve or the PRD.
- Creation of an additional vent in the cylinder valve.
- Creation of an additional vent in the cylinder wall.
- Dismantling of the cylinder valve.

Examples of methods for depressurizing gas cylinders with inoperable valves are given in Annex B.

Application of the preceding methods results in one of two modes of cylinder depressurization:

- a) where the gas is directly released to atmosphere. This mode is recommended for inert gases permitted for release to the atmosphere by relevant environmental regulations, or
- b) where the gas is not directly released to the atmosphere, but transferred from the original gas cylinder into a secondary gas containment area until disposed (see Figure B.2). This mode is recommended particularly for gases that pose a human and/or environmental hazard (such as toxic, corrosive, flammable or pyrophoric gases) as regulated by the relevant authority.

## 5.2 Choice of method

An appropriate method for handling pressurized gas cylinders with inoperable valves shall be chosen according to the hazard presented by the gas and the highest possible stored energy (pressure) in the cylinder.

When mode 5.1 a) is used, the work shall be carried out in a well-ventilated area or under a fume hood/inside a fume cabinet.

Mode 5.1 b) is used for gases such as toxic, corrosive, flammable or pyrophoric gases and also in cases of unknown gas content.

## 6 Procedures

### 6.1 Procedures to identify and segregate cylinders with inoperable valves

A valved cylinder shall only be devalved using a procedure described as follows:

Immediately prior to devalving any cylinder, it is essential to strictly apply a method for checking if gas pressure still remains in the cylinder. The method adopted shall be one described as follows or one that provides equivalent safeguards (for special valve designs, see 4.6).

- Use a device (e.g. rubber bulb) to hand pump atmospheric air (if gas content is compatible with air) into the cylinder and verify whether or not the gas flows unhindered into the cylinder (see Figure 1).
- Introduce a gas (inert and non-reactive to the cylinder content from a pressure source of approximately 5 bar) through the valve outlet and verify whether or not the gas flows unhindered into the cylinder.
- Introduce a sufficient quantity of gas (inert and non-reactive to the cylinder content from a pressure source of approximately 5 bar) through the valve outlet in order to verify whether or not gas flow is heard or seen exiting the cylinder.

After performing one of the preceding methods, any failed attempt to put gas through an open valve indicates that the valve is inoperable. Any valve that is found to be inoperable by any of the above methods shall be closed, if it was opened for the test, until further processed. Such a valved cylinder shall be treated as specified in 6.3.

Where procedures exist to vent a compressed gas safely and completely through the cylinder valve, including the recognition of a positive gas flow, and then to immediately remove this valve by the same operator, the preceding three methods need not be performed (see also 4.6.3).

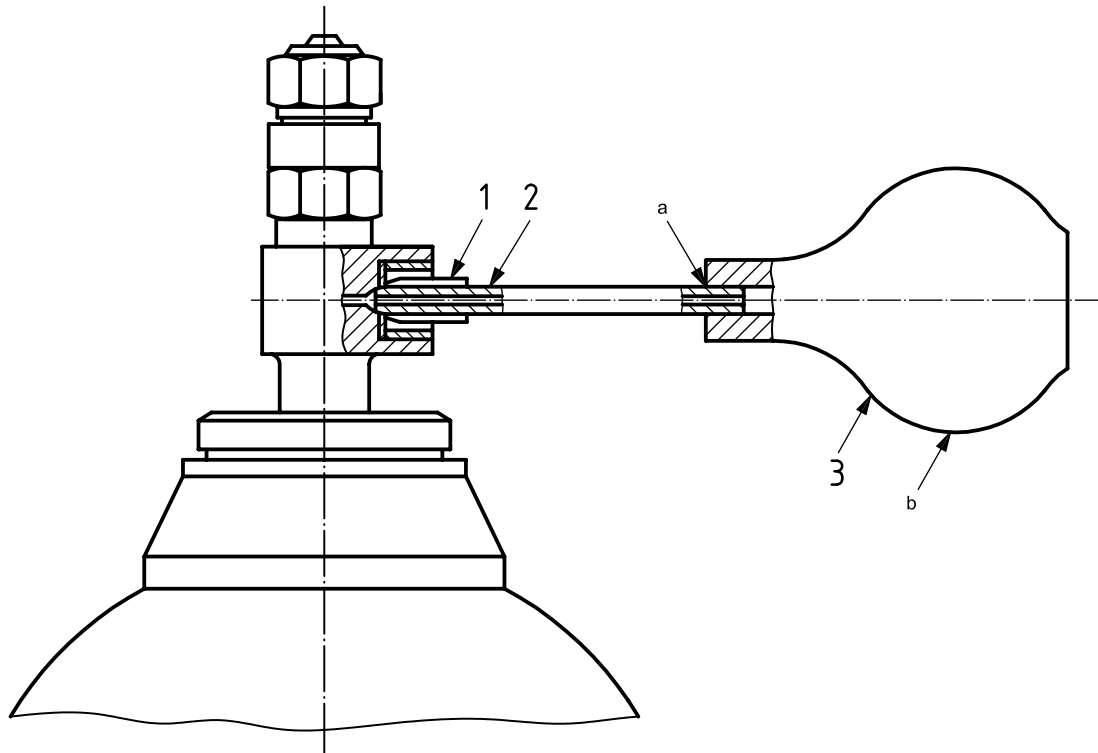

**Key**

- 1 flexible tube (internal diameter 8 mm, external diameter 13 mm) ground to olive shape and bonded
  - 2 tube (internal diameter 3 mm, external diameter 8 mm)
  - 3 flexible bulb
- a Bonded.
- b Hand pressure.

**Figure 1 — Typical device for detecting an inoperable cylinder valve**

## 6.2 Standard devalving procedure for treating cylinders with operable valves

### 6.2.1 Devalving procedure

Immediately after establishing that the cylinder is depressurized by having determined that the valve is operable, the devalving procedure may be started by using a devalving device in a safe manner (see 6.2.2). It can be necessary, for example in the case of toxic gas service, to purge the cylinder prior to the devalving procedure. If the valve is inoperable, see 6.3.

Any relevant valve removal recommendation from the cylinder/valve manufacturers shall be considered, where available.

A cylinder or valve can be damaged in this procedure. If this is the case, a determination shall be made whether the equipment can be repaired or be condemned. In any case, follow the relevant standards/regulations.

### 6.2.2 Devalving device

The devalving operation shall be performed with equipment and tools appropriate for the method and the contained gas, having considered potential operator errors (see 4.5). Attachment of equipment to the cylinder/valve shall be appropriate for the procedure and shall be safe for the operator.

## 6.3 Procedures for treating cylinders with inoperable valves

### 6.3.1 Facilities

Operations to depressurize cylinders with blocked or inoperable valves shall be carried out in a responsible manner to ensure that no hazardous conditions are created and that the environment is not harmed. Subsequent disposal of gases shall conform to requirements of the relevant authority (such as an environmental agency).

The area where this operation shall be performed shall be clearly designated. Affected employees of the facility shall be informed of the area, the type of operation and when work is being undertaken in this area. It is recommended that such an area be free of obstacles for an easy and quick exit. It should be possible for emergency personnel to easily access this area.

### 6.3.2 Equipment

Equipment shall be designed to withstand the maximum anticipated pressure and shall comply with relevant statutory requirements relating to gas cylinders.

The equipment shall also be compatible with the gas(es) with which it will be used, as specified in ISO 11114-1 and ISO 11114-2. In particular:

— For oxygen and other oxidizing gases (see ISO 10156-2), the equipment shall be constructed of compatible materials, free from flammable materials and clean for oxygen service.

NOTE For certain very powerful oxidants such as fluorine, passivation of the equipment might be necessary.

— For flammable and pyrophoric gases, the gas-wetted parts of the equipment shall be purged with an inert gas and free from air and oxidants or shall be able to withstand a fire or explosion.

— For corrosive gases, the equipment shall be constructed from compatible materials and dried before use.

— Spark-resistant tools shall be used for acetylene.

### 6.3.3 Depressurization

Depressurization of gas cylinders with inoperable valves requires operators with specialized training and experience. Annex B gives some examples of methods for depressurization of gas cylinders with inoperable valves. A full risk assessment of the chosen depressurization procedure(s) addressing all the hazards given in 4.2 shall be performed before starting the depressurization.

## 7 Damaged valves and cylinders

Any inoperable valve or damaged cylinder that is not repaired or cannot be repaired shall not be allowed to re-enter gas service. Any repaired equipment shall still comply with its relevant standard (periodic inspections) and regulations.



## Annex A (informative)

### Reasons cylinder valves become inoperable

#### A.1 Introduction

Cylinder valves can become either blocked or inoperable in the open or closed position. The reason is usually one of those given in A.2 to A.4.

#### A.2 Internal corrosion

Internal corrosion can prevent the operation of a valve when its operating mechanism is constructed from materials that are prone to corrosion by the environment or the gas. Many corrosive gases are hygroscopic, i.e. they absorb water from the atmosphere, and if gas users fail to purge valve outlets properly before and after use, highly corrosive conditions can occur inside the valve. If the valve operating mechanism is in contact with this corrosive material, seizure can occur.

#### A.3 Mechanical failure

Mechanical failure can directly result from internal corrosion as noted in A.2 (e.g. seizure of the valve operating mechanism followed by breakage due to attempts to overcome the seizure).

Mechanical failures can also occur as a result of material or construction faults, excessive wear in the valve's moving parts, impact damage and weaknesses in the valve design or because the operator has forced the valve closed by applying too much tightening torque. In some valve designs, the spindle can be operated without lifting the valve sealing device. Therefore, a full cylinder can appear empty, but the valve sealing device can suddenly lift and release gas.

#### A.4 Blockages

Blockage of a cylinder valve is usually due to one or more of the following materials entering the valve and compacting at the point where there is minimal cross section in the gas passage.

- Debris from inside the cylinder. Examples include polytetrafluoroethylene (PTFE) thread tape, shot and grit remaining from cylinder cleaning operations, and rust/corrosion or production/mill scale from cylinder walls.
- Debris compacted into the valve during filling. Examples include PTFE thread tape, grit and dirt, and purifier bed packings, such as alumina and molecular filter.
- Decomposition or other reaction products of the gas. Examples include:
  - ethylene oxide polymer;
  - metal and silicon oxides, which can result from their gaseous hydrides, e.g. phosphine and silane, coming into contact with air;
  - various reaction products, which can result if the user permits feedback of reactive materials into the cylinder or cylinder valve;

- metal halides, which can result from reaction of halogens with the cylinder or valve material, for example ferrous and ferric chloride, which can be produced from the action of wet hydrogen chloride on steel.
- Valve seat material. Valves fitted with a soft seat can become blocked by extrusion of the soft valve seat into the gas passage.
- Valve outlet connection cap seal. This can cause a blockage to the valve outlet when the connection cap seal has been extruded into it;
- Restricted flow orifice. Restricted orifice screwed inside the valve outlet connection can be easily blocked because of the small diameter, typically 0,5 mm.

For valves with a residual pressure function and valves incorporating an integrated pressure regulator, specific procedures are required (see 4.6.1).

## Annex B (informative)

### Examples of methods for depressurization of gas cylinders with inoperable valves

#### B.1 General

The methods described in this Annex are not intended to be detailed working procedures; rather, they are presented in a way to show variations of each case.

#### B.2 Methods

##### B.2.1 Release of gas by the creation of an additional vent in cylinder wall

An additional vent in the cylinder wall may be created to release gas by drilling into the cylinder wall where the drilling device forms a gas-tight seal to the cylinder wall via the use of a gasket (see Figure B.1).

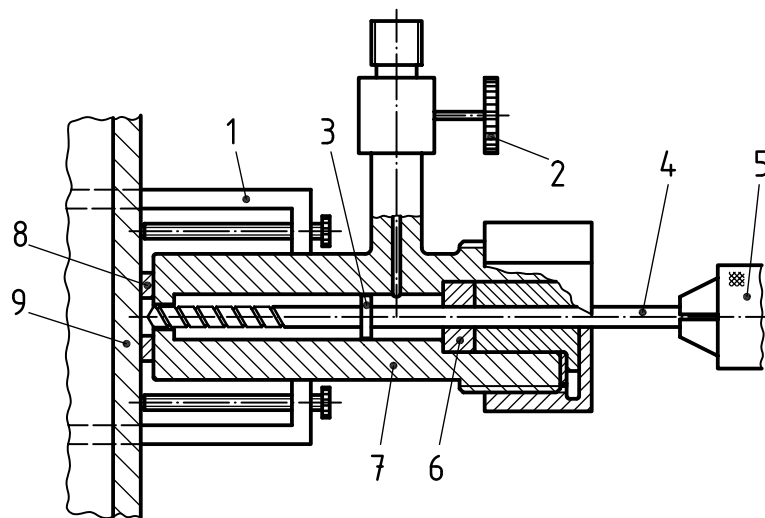

#### Key

- 1 device to firmly clamp drilling adaptor to cylinder wall
- 2 auxiliary valve
- 3 retaining collar
- 4 drill
- 5 hand drill machine
- 6 gland packing and gland nut (around drill)
- 7 drilling adaptor
- 8 gasket
- 9 cylinder wall

Figure B.1 — Drilling into cylinder wall (under pressure)

### B.2.2 Cylinder and valve enclosed inside coffin or jacket (that can hold the released pressure)

Procedure:

- a) Secure the cylinder.
- b) Fit the devalving head.
- c) Seal the coffin or gas jacket, if required (see Figures B.2 and B.3).
- d) Loosen the valve slowly by a manually operated or motor-driven tool.
- e) If possible, control gas release in a coffin or, if permissible, to the atmosphere.

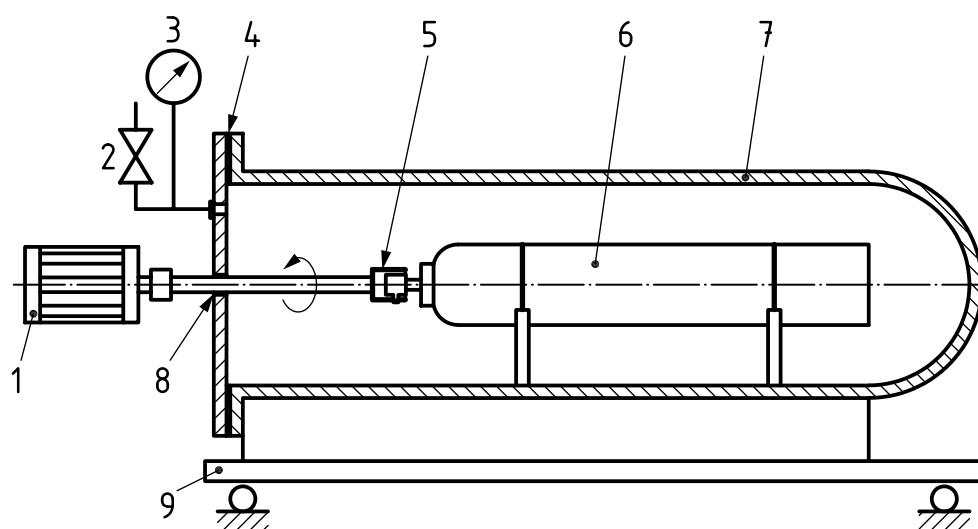

#### Key

- 1 manually operated or motor-driven tool
- 2 auxiliary valve
- 3 pressure gauge
- 4 gasket
- 5 devalving head
- 6 cylinder
- 7 coffin
- 8 gas-tight gland
- 9 portable support

Figure B.2 — Cylinder and valve enclosed inside coffin or jacket (that can hold the released pressure)

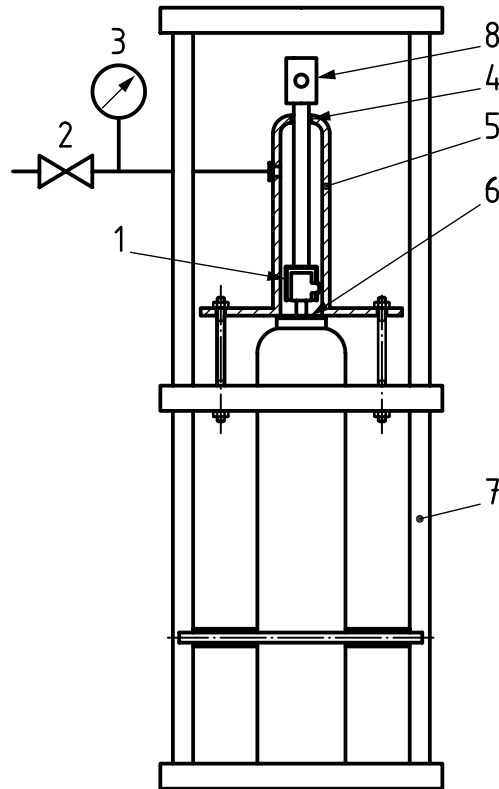

**Key**

- 1 devalving head
- 2 auxiliary valve
- 3 pressure gauge
- 4 gas-tight gland
- 5 gas-tight cap
- 6 gasket
- 7 cylinder securing frame
- 8 manually operated (as shown) or motor-driven tool

**Figure B.3 — Valve end of cylinder enclosed (that can hold the released pressure)**

**B.2.3 Release of gas by creation of an additional vent in the cylinder valve**

If the stem passage of the valve is blocked, the following methods do not work. When following these methods, extra care shall be taken before devalving to establish that no residual pressure remains in the cylinder.

An additional vent in the cylinder valve may be created to release gas by:

- a) Sawing into the valve stem (if the release of gas to atmosphere is permitted);
- b) Drilling along the axis of the valve outlet (under pressure) (see Figure B.4);
- c) Drilling into the valve body with the valve under a cylinder cap with a gas-tight seal, designed to the test pressure of the cylinder, which collects the released gases (see Figure B.5).

NOTE 1 This method is not suitable for gas cylinders with riveted or shrunk-on neckrings.

- d) Drilling into the valve body where the drilling device is gas tightened and fixed via a gasket to the valve body (see Figure B.6).

NOTE 2 The procedures mentioned in c) and d) are not recommended for test pressures greater than 30 bar.

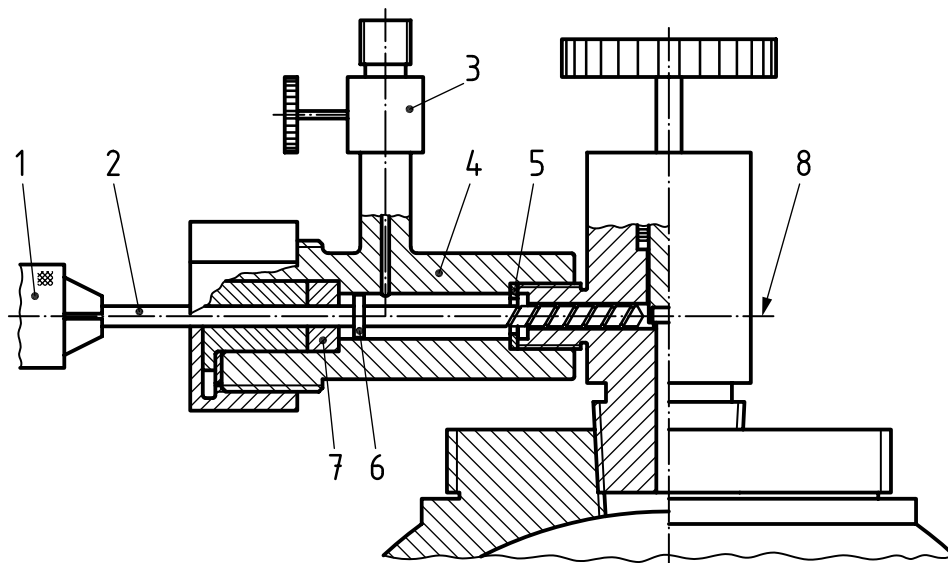

**Key**

- 1 hand drill machine
- 2 drill
- 3 auxiliary valve
- 4 drilling adaptor
- 5 gasket
- 6 retaining collar
- 7 gland packing and gland nut (around drill)
- 8 axis of the valve outlet

**Figure B.4 — Drilling on axis of valve outlet (under pressure)**

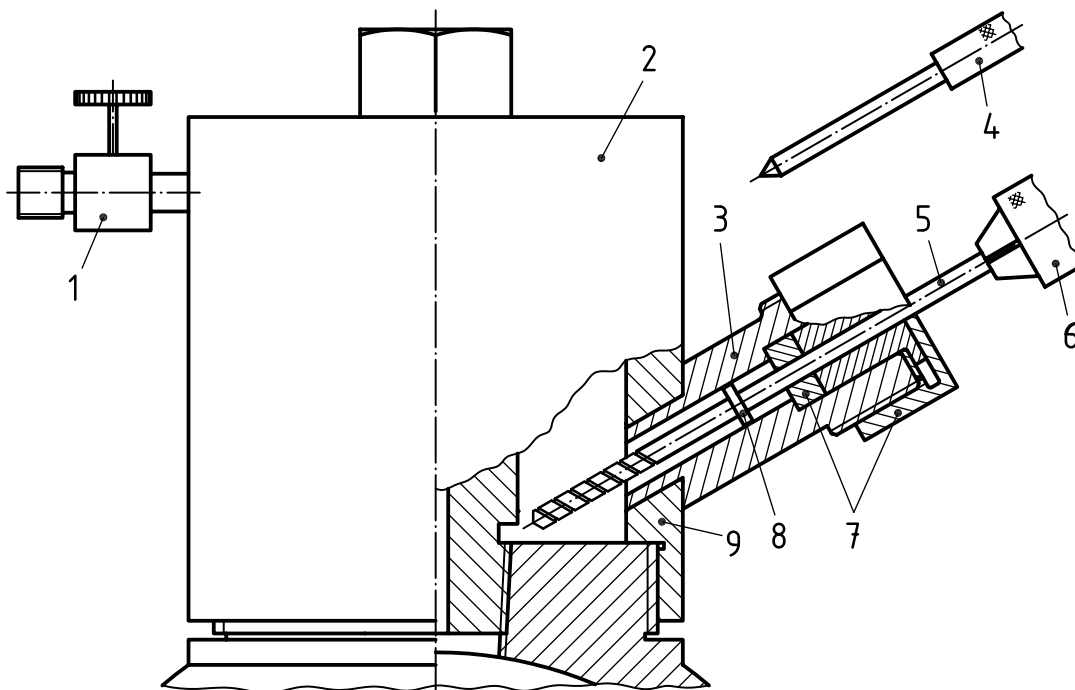

**Key**

- 1 auxiliary valve
- 2 cap held by restraining device
- 3 drilling adaptor
- 4 centre punch
- 5 drill
- 6 hand drill machine
- 7 gland packing and gland nut (around drill)
- 8 retaining collar
- 9 gasket

**Figure B.5 — Drilling into a valve body, valve end of gas cylinder enclosed**

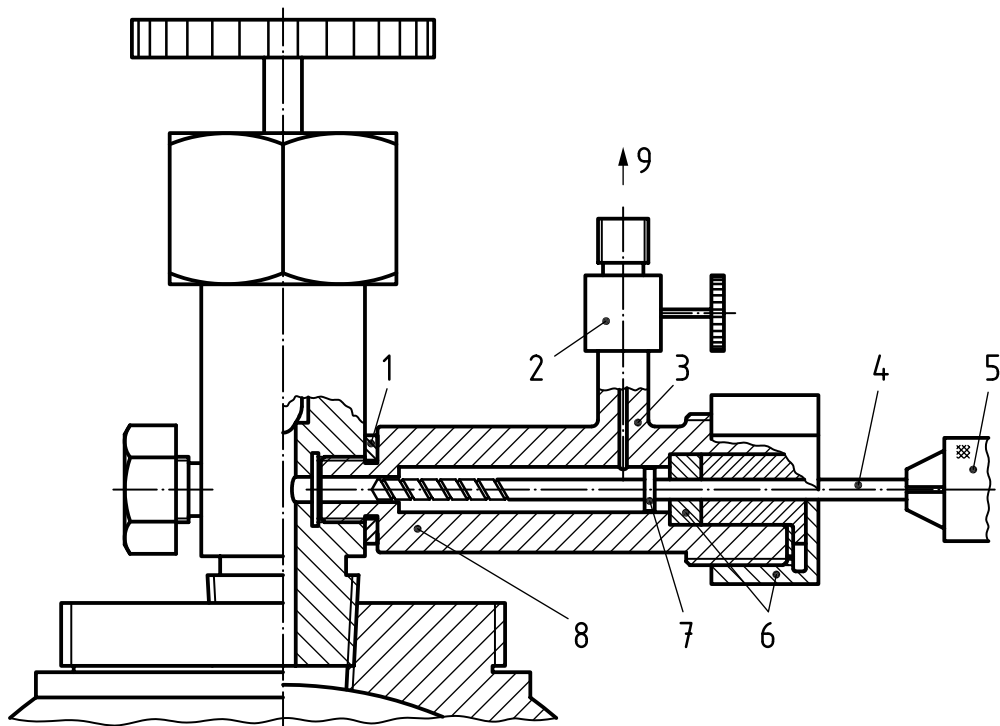

**Key**

- 1 gasket
- 2 auxiliary valve
- 3 drilling adaptor
- 4 drill
- 5 hand drill machine
- 6 gland packing and gland nut (around drill)
- 7 retaining collar
- 8 drilling adaptor threaded into or clamped onto valve body
- 9 released gas from the inoperable valve package into a secondary gas containment area

**Figure B.6 — Drilling into a valve body (under pressure)**

**B.2.4 Dismantling of the valve to facilitate movement of a broken spindle**

This method is used for valves designed with a solid one-piece spindle where the spindle has sheared. It is limited to valves where the gland nut is independent of the spindle thread. See Figure B.7.

Procedure:

- a) Secure the cylinder.
- b) Fit an auxiliary valve to the cylinder valve outlet.
- c) Carefully remove the gland nut, anticipating possible gas flow through the broken spindle; be prepared with emergency response equipment.
- d) Use a wrench on the remaining part of the spindle.
- e) Dispose of the gas safely.



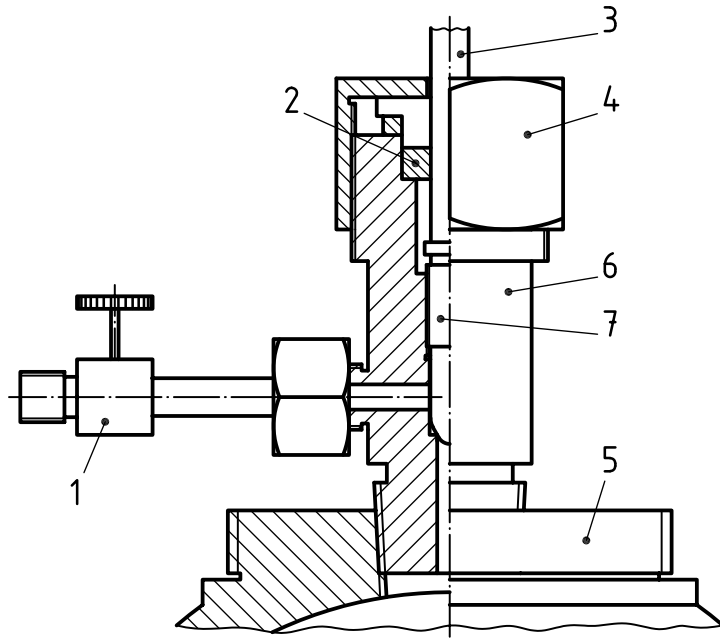

**Key**

- 1 auxiliary valve
- 2 gland packing
- 3 broken valve spindle
- 4 gland nut
- 5 cylinder
- 6 wrench area
- 7 sealing system

**Figure B.7 — Dismantling of the valve to facilitate movement of a broken spindle**

## Bibliography

- [1] ISO 6406, *Gas cylinders — Seamless steel gas cylinders — Periodic inspection and testing*
- [2] ISO 10156-2, *Gas cylinders — Gases and gas mixtures — Part 2: Determination of oxidizing ability of toxic and corrosive gases and gas mixtures*
- [3] ISO 10460, *Gas cylinders — Welded carbon-steel gas cylinders — Periodic inspection and testing*
- [4] ISO 10461, *Gas cylinders — Seamless aluminium-alloy gas cylinders — Periodic inspection and testing*
- [5] ISO 10462, *Gas cylinders — Transportable cylinders for dissolved acetylene — Periodic inspection and maintenance*
- [6] ISO 10464, *Gas cylinders — Refillable welded steel cylinders for liquefied petroleum gas (LPG) — Periodic inspection and testing*
- [7] ISO 15996, *Gas cylinders — Residual pressure valves — General requirements and type testing*
- [8] ISO 22435:2007, *Gas cylinders — Cylinder valves with integrated pressure regulators — Specification and type testing*
- [9] EIGA/IGC Document 129, *Pressure receptacles with blocked or inoperable valves*
- [10] EIGA/IGC Document 30, *Disposal of gases*
- [11] CGA P-38, First Edition, *Guidelines for Devalving Cylinders*



---

---

**ICS 23.020.30**

Price based on 18 pages



---

## BSI - British Standards Institution

BSI is the independent national body responsible for preparing British Standards. It presents the UK view on standards in Europe and at the international level. It is incorporated by Royal Charter.

### Revisions

British Standards are updated by amendment or revision. Users of British Standards should make sure that they possess the latest amendments or editions.

It is the constant aim of BSI to improve the quality of our products and services. We would be grateful if anyone finding an inaccuracy or ambiguity while using this British Standard would inform the Secretary of the technical committee responsible, the identity of which can be found on the inside front cover. Tel: +44 (0)20 8996 9000. Fax: +44 (0)20 8996 7400.

BSI offers members an individual updating service called PLUS which ensures that subscribers automatically receive the latest editions of standards.

### Buying standards

Orders for all BSI, international and foreign standards publications should be addressed to Customer Services. Tel: +44 (0)20 8996 9001. Fax: +44 (0)20 8996 7001 Email: [orders@bsigroup.com](mailto:orders@bsigroup.com) You may also buy directly using a debit/credit card from the BSI Shop on the Website <http://www.bsigroup.com/shop>

In response to orders for international standards, it is BSI policy to supply the BSI implementation of those that have been published as British Standards, unless otherwise requested.

### Information on standards

BSI provides a wide range of information on national, European and international standards through its Library and its Technical Help to Exporters Service. Various BSI electronic information services are also available which give details on all its products and services. Contact Information Centre. Tel: +44 (0)20 8996 7111 Fax: +44 (0)20 8996 7048 Email: [info@bsigroup.com](mailto:info@bsigroup.com)

Subscribing members of BSI are kept up to date with standards developments and receive substantial discounts on the purchase price of standards. For details of these and other benefits contact Membership Administration. Tel: +44 (0)20 8996 7002 Fax: +44 (0)20 8996 7001 Email: [membership@bsigroup.com](mailto:membership@bsigroup.com)

Information regarding online access to British Standards via British Standards Online can be found at <http://www.bsigroup.com/BSOL>

Further information about BSI is available on the BSI website at <http://www.bsigroup.com>

### Copyright

Copyright subsists in all BSI publications. BSI also holds the copyright, in the UK, of the publications of the international standardization bodies. Except as permitted under the Copyright, Designs and Patents Act 1988 no extract may be reproduced, stored in a retrieval system or transmitted in any form or by any means – electronic, photocopying, recording or otherwise – without prior written permission from BSI.

This does not preclude the free use, in the course of implementing the standard, of necessary details such as symbols, and size, type or grade designations. If these details are to be used for any other purpose than implementation then the prior written permission of BSI must be obtained.

Details and advice can be obtained from the Copyright and Licensing Manager. Tel: +44 (0)20 8996 7070 Email: [copyright@bsigroup.com](mailto:copyright@bsigroup.com)