

BS ISO 24631-7:2012



BSI Standards Publication

Radiofrequency identification of animals

Part 7: Synchronization of ISO 11785
identification systems

bsi.

...making excellence a habit.™

National foreword

This British Standard is the UK implementation of ISO 24631-7:2012.

The UK participation in its preparation was entrusted to Technical Committee AGE/6/1, Radio Frequency ID for Animals.

A list of organizations represented on this committee can be obtained on request to its secretary.

This publication does not purport to include all the necessary provisions of a contract. Users are responsible for its correct application.

© The British Standards Institution 2013. Published by BSI Standards Limited 2013

ISBN 978 0 580 71191 6

ICS 65.040.99

Compliance with a British Standard cannot confer immunity from legal obligations.

This British Standard was published under the authority of the Standards Policy and Strategy Committee on 31 January 2013.

Amendments issued since publication

Date	Text affected
------	---------------

**Radiofrequency identification of
animals —**

Part 7:
**Synchronization of ISO 11785
identification systems**

Identification des animaux par radiofréquence —

*Partie 7: Synchronisation des systèmes d'identification conformes à
l'ISO 11785*





COPYRIGHT PROTECTED DOCUMENT

© ISO 2012

All rights reserved. Unless otherwise specified, no part of this publication may be reproduced or utilized in any form or by any means, electronic or mechanical, including photocopying and microfilm, without permission in writing from either ISO at the address below or ISO's member body in the country of the requester.

ISO copyright office
Case postale 56 • CH-1211 Geneva 20
Tel. + 41 22 749 01 11
Fax + 41 22 749 09 47
E-mail copyright@iso.org
Web www.iso.org

Published in Switzerland

Contents

Page

Foreword	iv
Introduction	v
1 Scope	1
2 Normative reference	1
3 Terms and definitions	1
4 Abbreviations	2
5 Synchronization protocol	2
5.1 HDX detection.....	2
5.2 FDX detection.....	2
5.3 MRS (Mobile Reader Sync).....	3
5.4 Synchronization signals.....	3
5.5 Reader states.....	3
5.6 Period extensions.....	4
5.7 Possible situations.....	4
5.8 Possible error situations.....	6
6 System overview	7
7 Electrical specifications of bus	8
8 Synchronization method	8
9 Hardware suggestion for the synchronization circuit	11
9.1 Logic block.....	12
9.2 Synchronization detector.....	13
9.3 Transformer specifications.....	13
Annex A (normative) Synchronization timing diagram	15
Bibliography	17

Foreword

ISO (the International Organization for Standardization) is a worldwide federation of national standards bodies (ISO member bodies). The work of preparing International Standards is normally carried out through ISO technical committees. Each member body interested in a subject for which a technical committee has been established has the right to be represented on that committee. International organizations, governmental and non-governmental, in liaison with ISO, also take part in the work. ISO collaborates closely with the International Electrotechnical Commission (IEC) on all matters of electrotechnical standardization.

International Standards are drafted in accordance with the rules given in the ISO/IEC Directives, Part 2.

The main task of technical committees is to prepare International Standards. Draft International Standards adopted by the technical committees are circulated to the member bodies for voting. Publication as an International Standard requires approval by at least 75 % of the member bodies casting a vote.

Attention is drawn to the possibility that some of the elements of this document may be the subject of patent rights. ISO shall not be held responsible for identifying any or all such patent rights.

ISO 24631-7 was prepared by Technical Committee ISO/TC 23, *Tractors and machinery for agriculture and forestry*, Subcommittee SC 19, *Agricultural electronics*.

ISO 24631 consists of the following parts, under the general title *Radio frequency identification of animals*:

- *Part 1: Evaluation of conformance of RFID transponders with ISO 11784 and ISO 11785 (including granting and use of a manufacturer code)*
- *Part 2: Evaluation of conformance of RFID transceivers with ISO 11784 and ISO 11785*
- *Part 3: Evaluation of performance of RFID transponders conforming with ISO 11784 and ISO 11785*
- *Part 4: Evaluation of performance of RFID transceivers conforming with ISO 11784 and ISO 11785*
- *Part 5: Procedure for testing capability of RFID transceivers of reading ISO 11784 and ISO 11785 transponders*
- *Part 6: Representation of animal identification information (visual display/data transfer)*
- *Part 7: Synchronization of ISO 11785 identification systems*

Introduction

Wired synchronization is briefly explained in Clause C.2 of ISO 11785:1996.

This part of ISO 24631 describes in detail the method for synchronizing stationary ISO 11785 transmitters and receivers, as well as the method for allowing mobile readers to read ISO 11785 and Annex A transponders while in physical proximity of stationary readers.

Radiofrequency identification of animals —

Part 7:

Synchronization of ISO 11785 identification systems

1 Scope

This part of ISO 24631 specifies rules and procedures for synchronizing RFID transceivers while reading transponders used in individual animal identification complying to ISO 11784 and ISO 11785.

The synchronization scheme described herein may be fully implemented within each reader, and such readers when attached to the synchronization bus create a peer-to-peer network (all readers are equal – there is no dedicated master). Additionally, a cluster of readers, which could be in a master/slave configuration, may also be added to the bus using a dedicated, manufacturer specific Synchronization Interface. The Synchronization Interface presents to the synchronization bus electrical characteristics identical to those of a single peer-to-peer reader.

The transceiver conformance standard ISO 24631-2 permits activation on/off timing tolerances of $-0/+1$ ms and therefore gives reader manufacturers options as to their preferred method for detecting the HDX header; partial or full. However, when synchronizing readers, irrespective of which header detection method is used, it is critical that all readers adhere strictly to the specific timings and timing tolerances as given in the timing diagrams.

Particular attention should also be given to fault diagnostics which becomes more important when a reader network comprises products from different manufacturers. The obvious case is where a reader which is part of a network has become detached e.g. sync cable break, and it considers it's self to be now standalone and thus permitted to operate asynchronously to the detriment of all other readers.

2 Normative reference

The following documents, in whole or in part, are normatively referenced in this document and are indispensable for its application. For dated references, only the edition cited applies. For undated references, the latest edition of the referenced document (including any amendments) applies.

ISO 11784:1996, *Radio frequency identification of animals — Code structure*

ISO 11785:1996, *Radio frequency identification of animals — Technical concept*

3 Terms and definitions

For the purposes of this document, the following terms and definitions apply.

3.1

transceiver

device used to communicate with the transponder

3.2

transponder

radiofrequency identification (RFID) device that transmits its stored information when activated by a transceiver and that may be able to store new information

Note 1 to entry: See ISO 24631-1 for definitions of the main types.

3.3 transponder code

code as programmed in the transponder and defined in ISO 11784:1996 (Table 1) and ISO 11785

4 Abbreviations

FDX-B	full duplex communication protocol (conforming to ISO 11785, excluding protocols mentioned in Annex A of ISO 11785:1996)
HDX	half duplex communication protocol
RFID	radiofrequency identification

5 Synchronization protocol

For identification systems that conform to ISO 11784 and 11785, it is necessary to synchronize readers when two or more are used in physical proximity. Half duplex transponders convey data using two frequencies, one of which is the same frequency as the activation signal. When two or more readers operate independently (i.e. asynchronously), their respective activation signals can occur during the periods when other readers are attempting to receive HDX transponder signals. Consequently, readers will mutually interfere with one another unless the ON (reading of FDX transponders) and OFF (reading of HDX transponders) periods of the activation signals are synchronized. Synchronized readers transmit activation signals and receive HDX transponder signals in unison and will not interfere with each other.

The ISO 11785 Adaptive Timing protocol describes how a reader should behave when it detects a transponder. The synchronization protocol described in this part of ISO 24631 specifies how this behaviour is conveyed among readers. When a transponder is detected by a reader, this reader is allowed to extend the reading period for a certain time. The extension of the reading period is made known to other readers by means of a synchronization signal.

The ISO synchronization protocol described in Annex C of ISO 11785:1996 defines how readers in one network coordinate the ON and OFF periods of their respective transmitters. These patterns of ON and OFF periods are called cycles. One cycle comprises one ON period followed by one OFF period. These ON and OFF periods can be extended when transponders are detected. Every 10th cycle, a fixed ON/OFF pattern shall be generated. This cycle consists of a 50 ms ON period for receiving FDX transponders and a 20 ms OFF period for receiving HDX transponders. This 10th cycle allows a mobile reader not connected with the wired synchronization network of the stationary readers, to receive the transponders.

5.1 HDX detection

A normal cycle of an idle (non-detecting) reader comprises a 50 ms ON period followed by a 4 ms OFF period. When a reader detects a HDX transponder, it will extend the OFF period to 20 ms. To do this, it will tell the other readers in the network that the period shall be extended by asserting a sync signal on the network. All readers connected to the wired synchronization network see the sync signal and extend their respective OFF periods to 20 ms. In this extended OFF period, the reader can receive the full transponder information. The extended OFF period for HDX receiving is always a fixed 20 ms.

5.2 FDX detection

When a reader detects an FDX transponder, there is generally sufficient time to receive the complete information within the 50 ms ON period of a cycle. However, if the transponder is not received completely, the reader is allowed to extend the ON period. However, the maximum reading period for FDX is 100 ms, and the reader is not allowed to extend the ON period beyond this maximum reading time. As in the HDX case, the reader asserts a sync signal on the network in order to tell the other readers that an extension of the reading time is required.

The 10th cycle is a special case where it is not allowed to extend the FDX period and, additionally, the HDX period is always extended to 20 ms.

5.3 MRS (Mobile Reader Sync)

Every 10th cycle is identified by the MRS pulse on the synchronization network during the 20 ms OFF period. Each reader in the network is capable of asserting this pulse. However, a reader is allowed to generate the pulse only when it determines that there is no other pulse on the synchronization network. Each reader synchronizes on the leading edge of this pulse.

5.4 Synchronization signals

Every reader generates the three possible signals:

- | | |
|-----------------------------------|---|
| 1) MRS (Mobile Reader Sync pulse) | 20 ms ±0,5 ms |
| 2) HDX extension | 16,4 ms $^{+0,6}_{-0,1}$ ms |
| 3) FDX extension | $n \times 2$ ms ($1 < n < 25$), ($n \neq 10$) ±0,5 ms |

5.5 Reader states

A reader exists in either of two possible states: the initialization state or the operational state. During the initialization state, a reader searches for other readers in the network and will attempt to synchronize with them. During the operational state, a reader is synchronized and is able to read FDX and HDX transponders.

5.5.1 Initialization

Upon powering on, a reader monitors the synchronization network in order to detect either an MRS pulse or an ON/OFF period extension signal. When activity has been detected, the reader searches for the MRS pulse. The end of the MRS pulse marks the beginning of cycle number one. Once synchronized with the other readers, the reader enters the operational state.

NOTE A reader will wait for the MRS pulse after it has detected activity on the sync line. If, however, activity is detected and no MRS pulse identified, an indeterminate situation arises and the reader remains in the initialization state and continues to search for the MRS pulse. If no activity is detected within approximately 1,2 s, the initializing reader will generate an MRS pulse and will enter the operational phase.

5.5.2 Operational

During the operational state, the reader performs the following tasks in order to stay synchronized.

- It starts the cycle counter after detecting an MRS pulse.
- Every 10th cycle, a reader may generate an MRS pulse. Note that only one reader generates the MRS pulse, namely the fastest one.
- It maintains the FDX and HDX periods in accordance with the timing shown in Annex A.
- When the reader expects an MRS pulse, but a longer pulse is detected on the synchronization network, the reader reverts to the initialization state and searches for the MRS pulse (see 5.7.1).
- If a reader sends an MRS pulse and detects an incorrect MRS pulse on the synchronization network, it reverts to the initialization state and searches for the MRS pulse (see 5.7.2)

5.6 Period extensions

5.6.1 General

The MRS pulse shall be unique in its pulse duration. Signals that indicate period extensions are not allowed to be exactly equal to the MRS pulse. Therefore, the following rules apply to these signals.

5.6.2 Extend FDX period

- Start ≤ 49 ms after the beginning of the FDX period.
- It is not allowed to be $20 \text{ ms} \pm 0,5 \text{ ms}$.
- Total FDX period is max. 100 ms.
- Each 10th cycle, the FDX period is not allowed to be extended (fixed 50 ms).
- The extension may use 2 ms increments.

5.6.3 Extend HDX period

- Start extension between 3 ms and 4 ms.
- Total HDX period is 20 ms.
- The extension shall be less than 17 ms.

5.6.4 MRS pulse

- It is $20 \text{ ms} \pm 0,5 \text{ ms}$.
- Start immediately after the FDX period.
- Generate every 10th cycle if no sync pulse already present.

5.7 Possible situations

5.7.1 No transponders are present

The transmitter is now ON for 50 ms (the FDX period) and OFF for 4 ms (the HDX period). Each 10th cycle, a fixed pattern is present of 50 ms FDX ON period and 20 ms OFF period. The readers try to generate an MRS pulse if there is no activity on the sync line yet. Reader 1 generates the MRS pulse and reader 2 sees the activity on the sync line and therefore will not generate an MRS pulse. All readers commence the 1st cycle with the FDX cycle on the falling edge of the MRS pulse. An overview of the sync lines and field status is given in Figure 1.

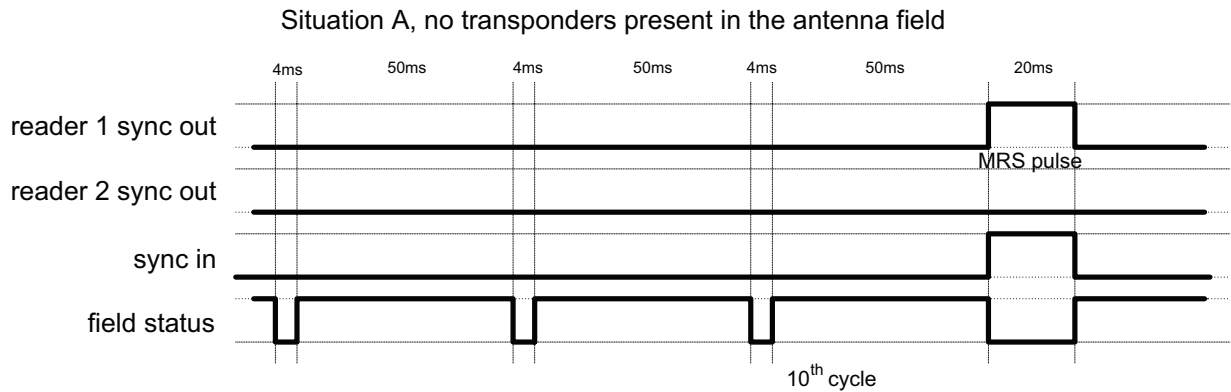

Figure 1 — Overview of the sync lines and field status with no transponder present in the antenna field

5.7.2 FDX transponder is present

A reader detecting an FDX transponder will try to read the information of that transponder. If the reader does not succeed after 49 ms, it will extend the ON period. This is made known to the other readers by asserting the sync signal. The sync signal will be de-asserted when the transponder has been read or when the maximum of the FDX reading period (i.e. 100 ms) has been reached. All readers stop their respective transmitters in response to de-assertion of the sync signal. Note that an extension time of 20 ms is not allowed because of possible confusion with the MRS pulse. Another condition to be met is that the 10th cycle shall be 50 ms and cannot be extended. The extended period may therefore be 52, 54, 56, ... 66, 68, 72, 74, ... 98, 100 ms. An overview of the sync lines and field status is given in Figure 2.

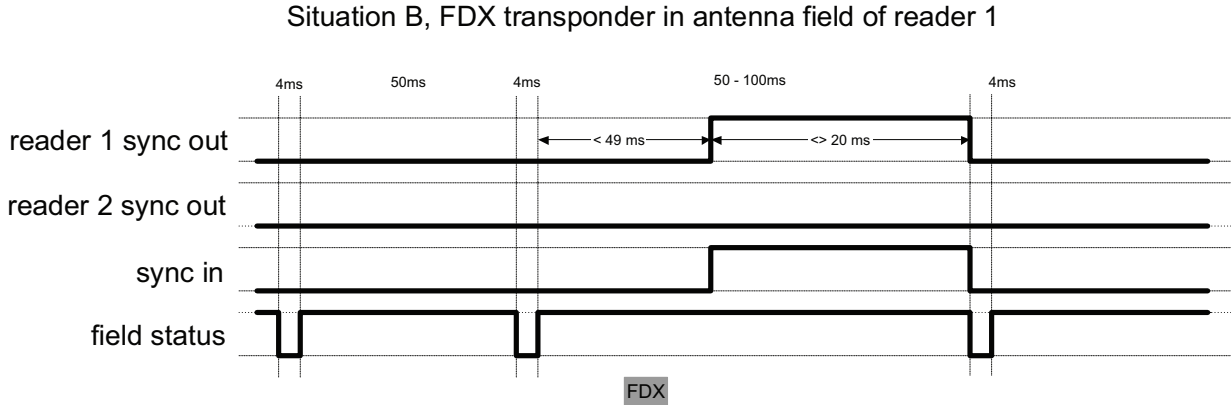

Figure 2 — Overview of the sync lines and field status with a FDX-B transponder present in the antenna field

5.7.3 HDX transponder is present

Detection of a HDX transponder by a reader results in an HDX reading period of 19,4 ms $\begin{matrix} +0,6 \\ -0,1 \end{matrix}$ ms. The sync signal is now made high between 3 ms and 4 ms after the start of the HDX period. This ensures that the duration of the sync signal is always less than 20 ms. Again, all other readers detect the sync signal and will also extend their respective ON periods to 20 ms. An overview of the sync lines and field status is given in Figure 3.

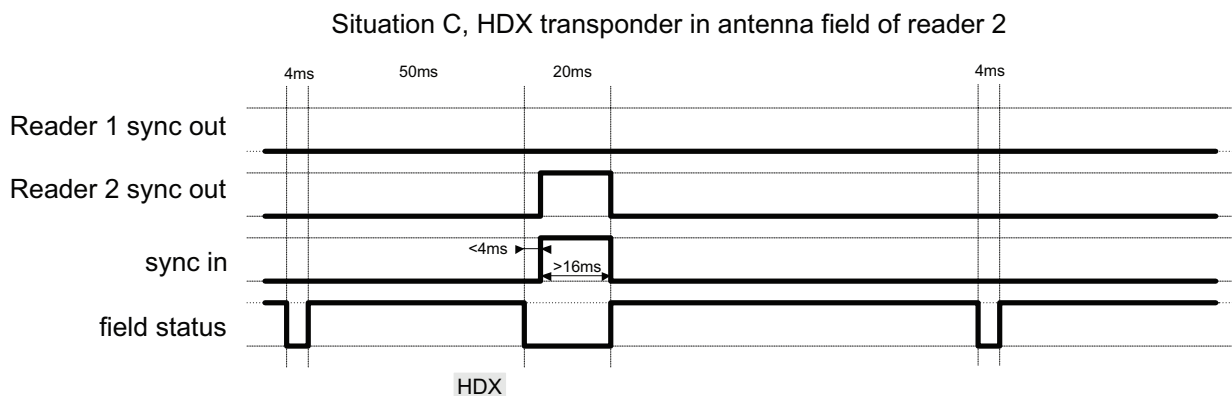

Figure 3 — Overview of the sync lines and field status with a HDX transponder present in the antenna field

5.7.4 10th cycle pattern

Every 10th cycle, a fixed pattern of 50 ms FDX ON period and 20 ms HDX OFF period is introduced where mobile readers are able to read the transponders. Each stationary reader is synchronized and may try to generate the MRS pulse. As long as no reader has asserted a sync signal, more than one reader may simultaneously assert the MRS pulse. However, when a reader detects the beginning of an MRS pulse on the sync network, that reader refrains from asserting an MRS pulse. This is to ensure that the MRS pulse is exactly 20 ms. An overview of the sync lines and field status is given in Figure 4.

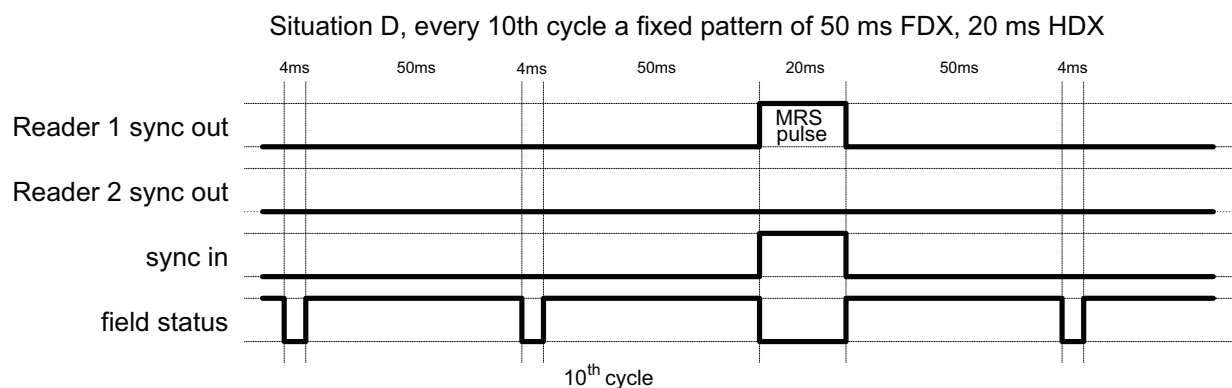

Figure 4 — Overview of the sync lines and field status during the 10th cycle, with fixed pattern of 50 ms FDX-B and 20 ms HDX

5.8 Possible error situations

5.8.1 Unexpected MRS pulse

Suppose reader 1 is in the 8th cycle and reader 2 generates an MRS pulse. Reader 1 will now synchronize to the MRS pulse and starts with the 1st cycle after the falling edge of the MRS pulse. An overview of the sync lines and field status is given in Figure 5.

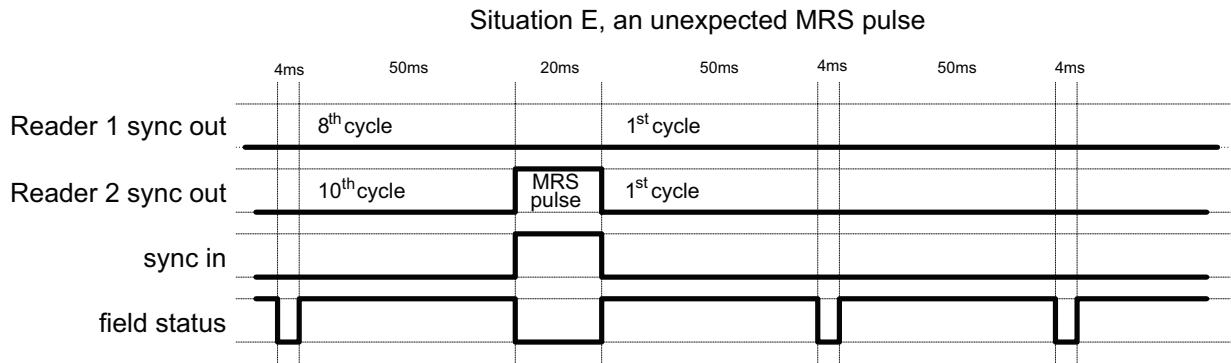

Figure 5 — Overview of the sync lines and field status with an unexpected MRS pulse

5.8.2 One reader is no longer synchronized

Suppose reader 2 is no longer synchronized with the other readers. This reader can distort the sync signals as pictured in Figure 6. The normal MRS pulse is extended by the erroneous reader 2. The other readers discover that the MRS pulse is longer than it is supposed to be and those readers will now revert to the initialization state and search for a correct MRS pulse on the sync network. Reader 1 detects that his MRS pulse is not correctly on the sync line and will therefore also revert to the initialization state and search for an MRS pulse. Reader 2 will continue with the cycles and eventually generate an MRS pulse. All other readers are in the initialization state, and identify and synchronize with this MRS pulse. If reader 2 also reverts to the initialization state before it has generated an MRS pulse, then all readers will be in the initialization state. The inherently fastest reader will complete the search interval first, and will assert an MRS pulse to which all other readers will synchronize. An overview of the sync lines and field status is given in Figure 6.

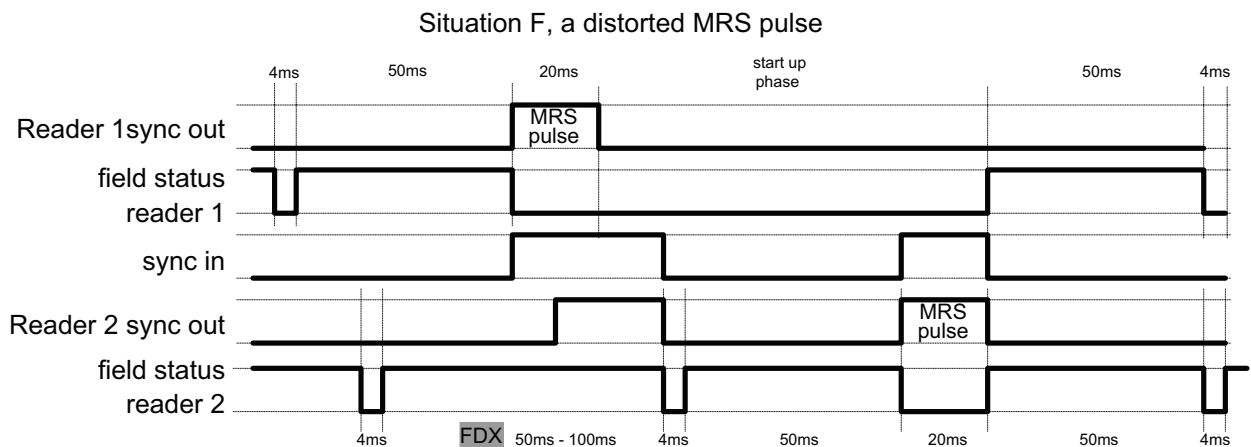

Figure 6 — Overview of the sync lines and field status with a distorted MRS pulse

6 System overview

The involved readers are connected to each other by way of a two wire cable. The synchronization signal, comprising a 53,68 kHz AC voltage, coordinates the ON and OFF periods of the transmitters of all readers. In this synchronization scheme, all readers are equal – there is no master or slave. Due to the use of transformers, the network is isolated from the electronics inside the reader. The connection is phase independent.

Synchronization occurs when two or more readers are connected to the bus. The system is hot pluggable and the readers are designed to have a high impedance at the synchronization input when switched off. Therefore, power down at one or more of the connected readers will not influence the synchronization scheme.

A complete synchronization cycle has a variable length and is dependent of the number of extension requests. The minimum length is 556 ms; the maximum value is 1 150 ms. The synchronization cycle starts at the rising edge of the MRS pulse. The MRS pulse is identified by its unique duration (20 ms \pm 0,5 ms). An event starts with the MRS pulse rising edge when at that time it is not certain the rising edge is that of the MRS pulse.

7 Electrical specifications of bus

— synchronization signal:	AC	$0,4 \times f$ carrier of the transmitter
— synchronization frequency:	53 680 Hz	± 3 Hz (± 50 ppm)
— wiring type:	2 wire, phase-independent	
— amplitude:	$0,7 V_{RMS}$	± 20 % (open voltage)
— output impedance:	50Ω	± 20 % (while transmitting sync)
— input impedance:	$> 1\,000 \Omega$	- 20 % (while receiving sync)
— input threshold level:	$200 mV_{RMS}$	± 20 %
— max. noise level:	$70 mV_{RMS}$	
— delay time rising edge:	$< 3,5 \mu s$	(TX reader to RX reader)
— delay time falling edge:	$< 250 \mu s$	(TX reader to RX reader)
— connection:	isolated by means of a transformer	
— possible number of readers:	up to 16	
— possible bus length:	> 500 m	(total wire length)

8 Synchronization method

Every reader connected to the synchronization bus shall examine the signals on this bus before it is allowed to create its own synchronization signals. This is also the situation after starting up a reader that was switched off for a certain period.

The reader starts in the initialization state searching for the MRS pulse indicating the 10th interrogation cycle within one synchronization frame. It is always found within 1 150 ms after the start of the search and has a unique length of 20 ms (1 074 cycles of the 53,68 kHz signal), with tolerance of $\pm 0,5$ ms.

If no MRS pulse is found, the reader can conclude that there is no other reader active on the bus and it can assert its own MRS and extension synchronization signals onto the bus. If an MRS pulse is found, the reader resets its internal clock at the rising edge of the "Sync det." signal (Figure 2) starting the first cycle.

Figure 7 shows an example of an MRS pulse.

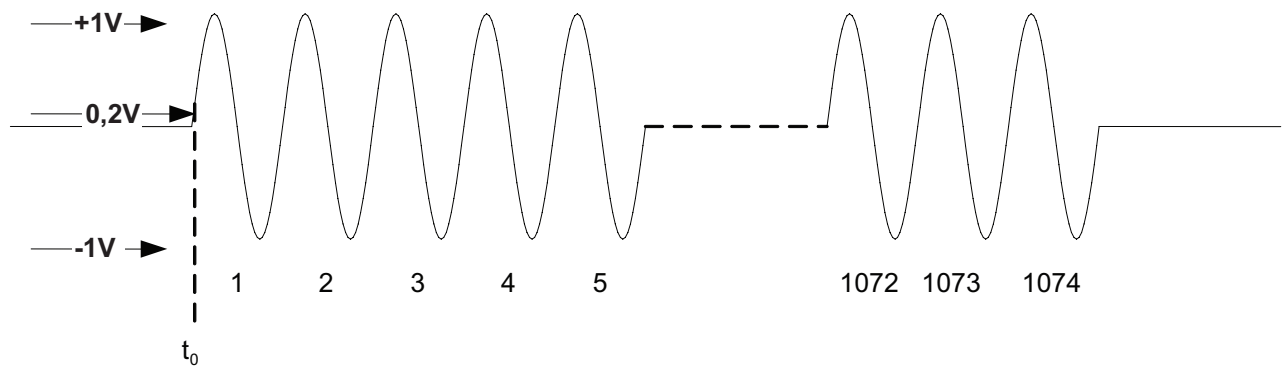

Figure 7 — MRS pulse

The threshold level for detecting a positive or negative cycle of the 53,68 kHz is approximately 0,2 V and the moment t_0 is a little bit dependent of the amplitude of the received signal. Under normal conditions, the signal has the specified amplitude of 2 V_{pp} and the 0,2 V is reached 0,6 μs after the start of transmission of a synchronization signal. At the minimum level, 0,2 V_{RMS}, the detection is at 45° of the cycle and completed after 2,3 μs.

Delay on the cable (approximately 1 μs for every 200 m), adds more delay to the period between a transmission and reception of a request.

The maximum allowed delay is 3,5 μs.

NOTE The use of 500 m wire, as specified, can give more than 3,5 μs delay. In normal situations, the 500 m is defined as the addition of all pieces of wire that are used to connect a large number of readers. There is no reason to synchronize readers that are 500 m apart from each other!

The moment that the first cycle of the 53,68 kHz has arrived, the synchronization is still not detected in the receiving readers.

As shown in Figure 8, the detection of the first (positive or negative) cycle is used to create the “TX block” signal. This signal indicates that temporarily it is not allowed to transmit a synchronization request.

If two readers transmit at the same time a synchronization signal with 180° difference, a complete cancelling of the signal is theoretically possible. To avoid this situation, there are two rules:

- a) always start transmitting with the polarization of last received synchronization signal;
- b) never start a transmission of synchronization after detecting the “TX block” signal.

Sometimes two readers start at (nearly) exactly the same time with a synchronization request. In this situation, they cannot detect the TX block signal. This is a special, allowed situation. Because the signals are of the same frequency and phase, they add together and the resulting signal is still detectable by the other connected readers. Even if the delay between the two transmitting readers is a quarter of a period (90°), this addition is still no problem for the transfer of the synchronization signal.

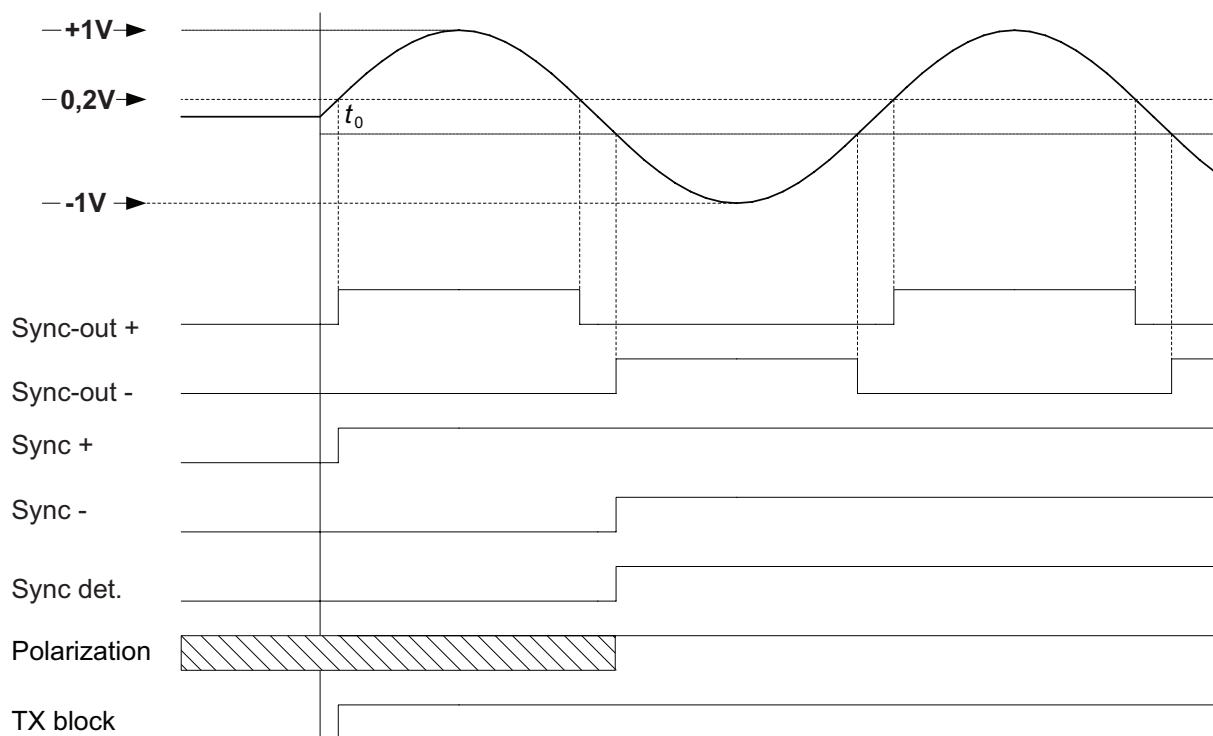

Figure 8 — Synchronization pulse rising edge

To cope with rule number one, every reader shall create the “Polarization” signal. A circuit detects the first appearance of Sync-out+ and the Sync-out- signals. The order of detection of these two signals determines the value of this signal. A temporary register is first filled with the Polarization signal. After the “Sync det.” is valid, this temporary status is changed in a definitive one. This will avoid that the register is changed by noise on the bus.

To create the “Sync det.” signal, the Sync+ and Sync- signals have to be high.

The falling edge of the synchronization signal is less accurate than the rising edge, due to signal reflection and ringing on the cable. As a result of this ringing, detection of the falling edge is done in a different way to that of the rising edge.

At the end of a synchronization message, it is possible that the signal on the cable has an amplitude as seen in Figure 9.

The resulting signals below show an unstable Sync-out+ and Sync-out- output. With a delay of approximately 140 μ s (7 cycles of the 53,68 kHz), the “Sync det.” signal is stable during this period of ringing on the cable. The 140 μ s is relatively short compared to the time that this signal is active during synchronization.

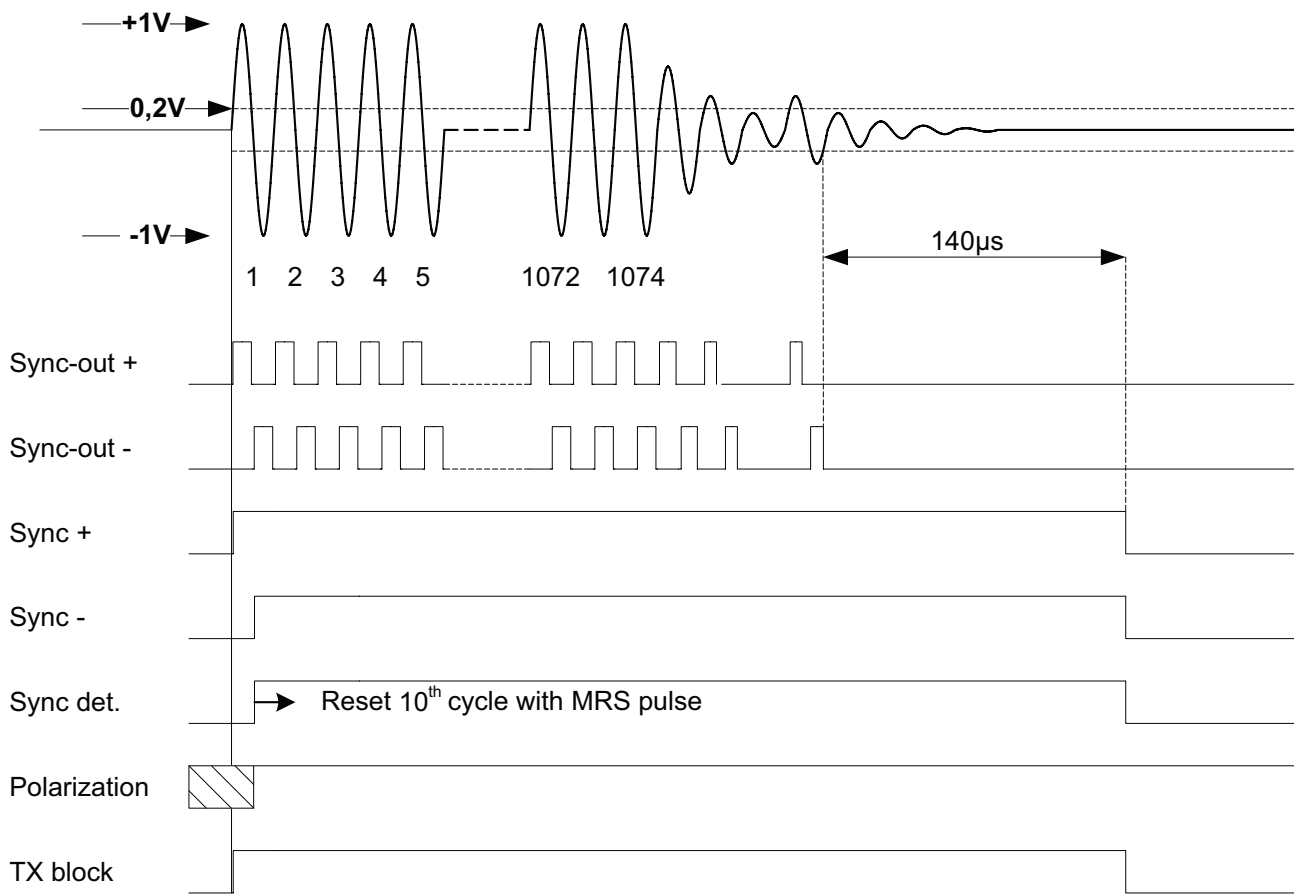

Figure 9 — Synchronization pulse falling edge

9 Hardware suggestion for the synchronization circuit

In the previous clause, the most important information for designing a circuit for synchronization of an ISO reader conforming to ISO 11784 / ISO 11785 is given. This circuit consists of a microcontroller and a small amount of hardware. The control of the hardware and the protocol is relatively simple and in most applications this extra task is done by the existing μ -controller that controls the reader.

A block-diagram of the hardware is shown in Figure 10. In this diagram, the relation of the sync-circuit with the transmitter section is also shown. The synchronization frequency is generated by the same source as the one for the transmitter. This prevents the reception of unwanted coupling between (weak) harmonics of the sync and transmitter signals. With this coupling, the resulting frequencies are always zero or far beyond the bandwidth of those from the received tag.

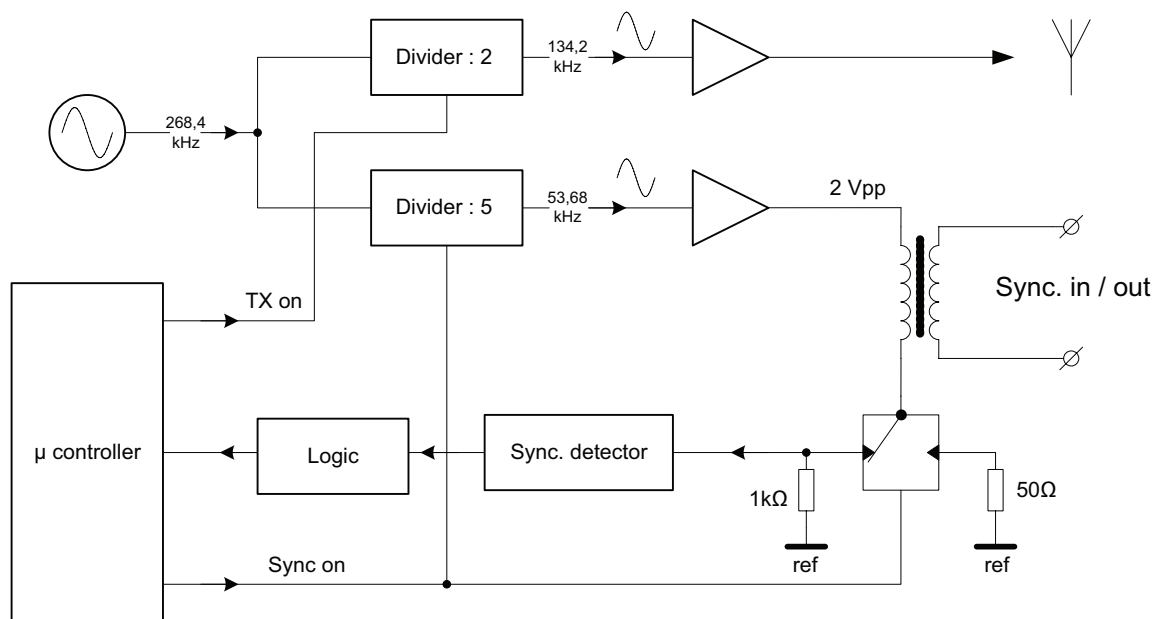

Figure 10 — Synchronization circuit

9.1 Logic block

The sync detector generates the Sync-out+ and Sync-out- signals. These signals are fed to the Logic block. In Figure 11, this Logic block is shown in more detail to help the user design this simple circuit. The circuit either consists of a few chips or is constructed as a part of an ASIC.

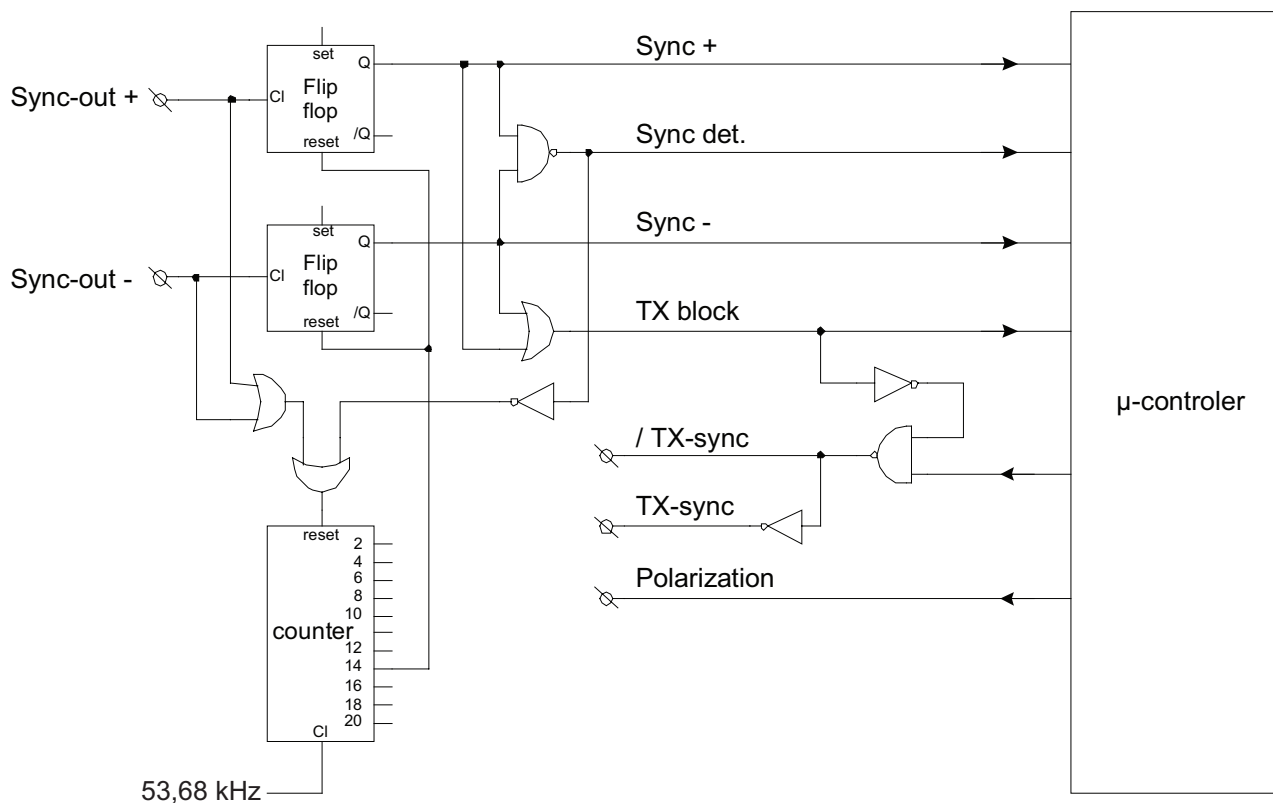

Figure 11 — Synchronization circuit — Logic block

This can be accomplished, for example, with a RM5 core of 3C85 without an airgap.

The transformer will have a self-inductance of 20 mH or more if wound with 2 times 100 windings
0,16 mm Cul.

Annex A (normative)

Synchronization timing diagram

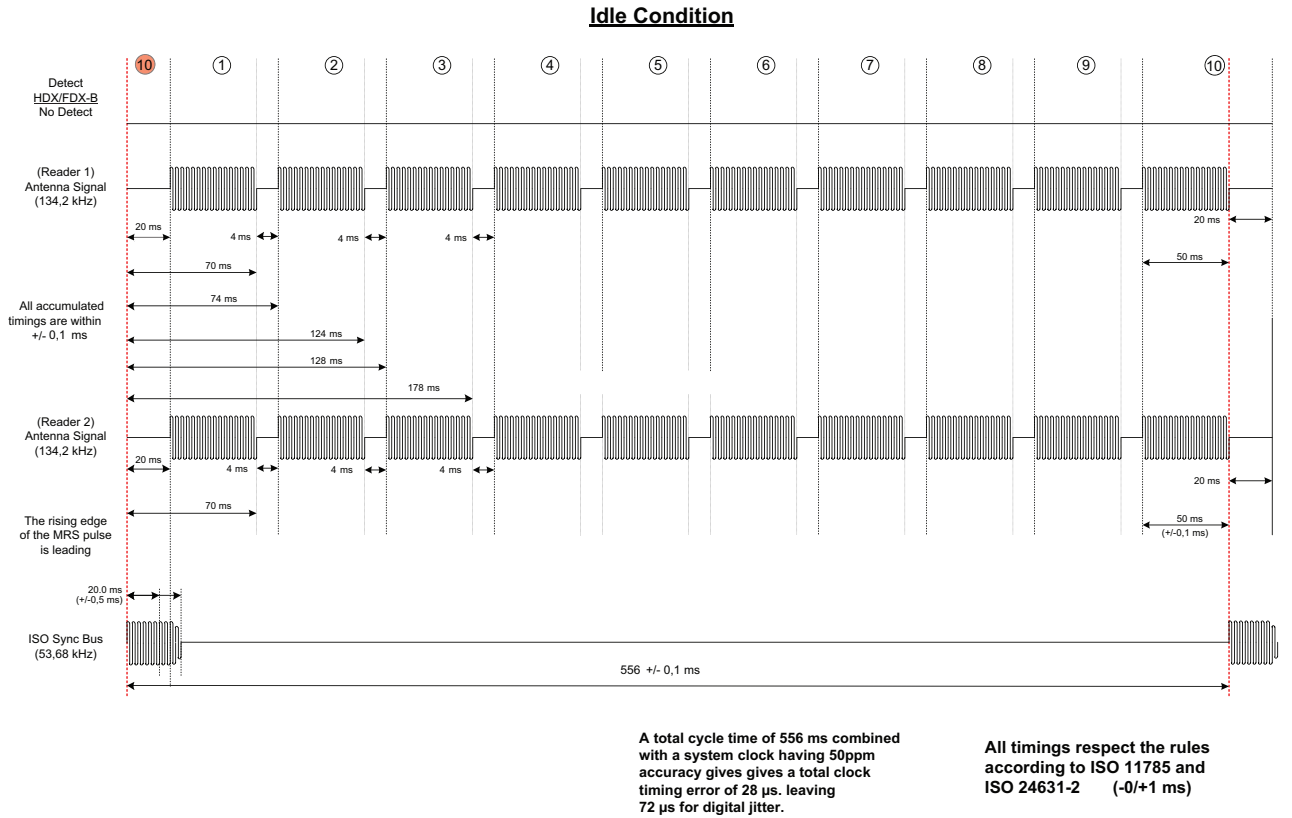

Figure A.1 — No transponders present in field of the readers

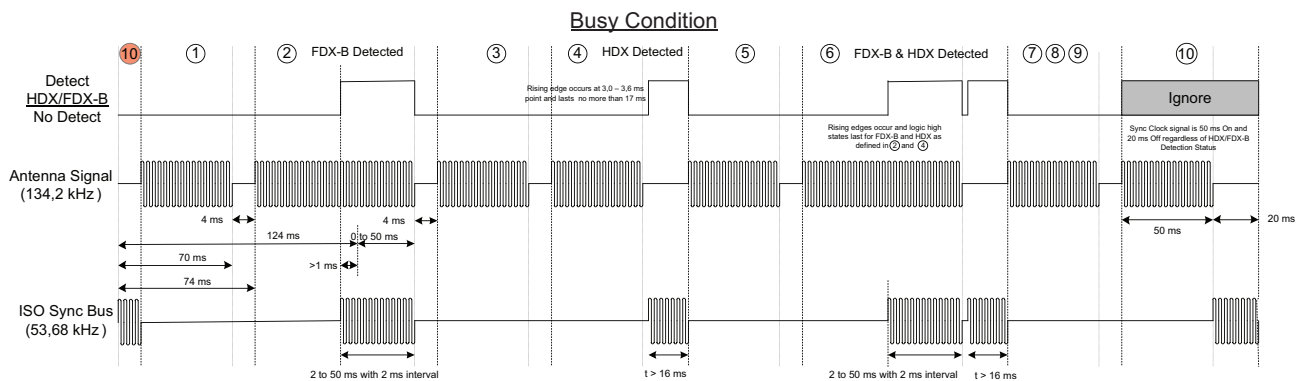

Figure A.2 — FDX-B and HDX transponders present in field of reader

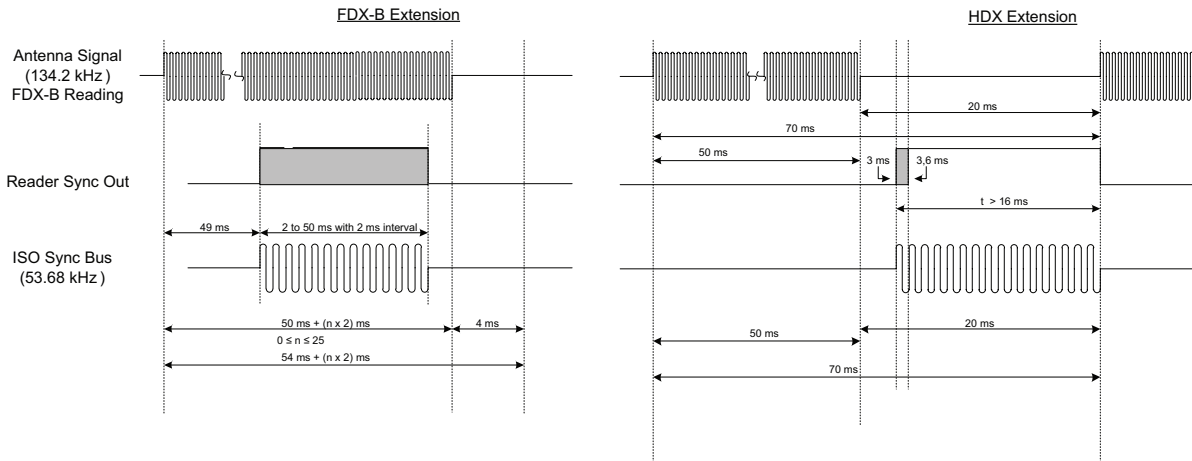

Figure A.3 — Detail of the FDX-B and HDX extension

Bibliography

- [1] ISO 3166 (all parts), *Codes for the representation of names of countries and their subdivisions*
- [2] ISO 24631-1:2009, *Radiofrequency identification of animals — Part 1: Evaluation of conformance of RFID transponders with ISO 11784 and ISO 11785 (including granting and use of a manufacturer code)*
- [3] ISO 24631-2:2009, *Radiofrequency identification of animals — Part 2: Evaluation of conformance of RFID transceivers with ISO 11784 and ISO 11785*

British Standards Institution (BSI)

BSI is the national body responsible for preparing British Standards and other standards-related publications, information and services.

BSI is incorporated by Royal Charter. British Standards and other standardization products are published by BSI Standards Limited.

About us

We bring together business, industry, government, consumers, innovators and others to shape their combined experience and expertise into standards-based solutions.

The knowledge embodied in our standards has been carefully assembled in a dependable format and refined through our open consultation process. Organizations of all sizes and across all sectors choose standards to help them achieve their goals.

Information on standards

We can provide you with the knowledge that your organization needs to succeed. Find out more about British Standards by visiting our website at bsigroup.com/standards or contacting our Customer Services team or Knowledge Centre.

Buying standards

You can buy and download PDF versions of BSI publications, including British and adopted European and international standards, through our website at bsigroup.com/shop, where hard copies can also be purchased.

If you need international and foreign standards from other Standards Development Organizations, hard copies can be ordered from our Customer Services team.

Subscriptions

Our range of subscription services are designed to make using standards easier for you. For further information on our subscription products go to bsigroup.com/subscriptions.

With **British Standards Online (BSOL)** you'll have instant access to over 55,000 British and adopted European and international standards from your desktop. It's available 24/7 and is refreshed daily so you'll always be up to date.

You can keep in touch with standards developments and receive substantial discounts on the purchase price of standards, both in single copy and subscription format, by becoming a **BSI Subscribing Member**.

PLUS is an updating service exclusive to BSI Subscribing Members. You will automatically receive the latest hard copy of your standards when they're revised or replaced.

To find out more about becoming a BSI Subscribing Member and the benefits of membership, please visit bsigroup.com/shop.

With a **Multi-User Network Licence (MUNL)** you are able to host standards publications on your intranet. Licences can cover as few or as many users as you wish. With updates supplied as soon as they're available, you can be sure your documentation is current. For further information, email bsmusales@bsigroup.com.

BSI Group Headquarters

389 Chiswick High Road London W4 4AL UK

Revisions

Our British Standards and other publications are updated by amendment or revision.

We continually improve the quality of our products and services to benefit your business. If you find an inaccuracy or ambiguity within a British Standard or other BSI publication please inform the Knowledge Centre.

Copyright

All the data, software and documentation set out in all British Standards and other BSI publications are the property of and copyrighted by BSI, or some person or entity that owns copyright in the information used (such as the international standardization bodies) and has formally licensed such information to BSI for commercial publication and use. Except as permitted under the Copyright, Designs and Patents Act 1988 no extract may be reproduced, stored in a retrieval system or transmitted in any form or by any means – electronic, photocopying, recording or otherwise – without prior written permission from BSI. Details and advice can be obtained from the Copyright & Licensing Department.

Useful Contacts:

Customer Services

Tel: +44 845 086 9001

Email (orders): orders@bsigroup.com

Email (enquiries): cservices@bsigroup.com

Subscriptions

Tel: +44 845 086 9001

Email: subscriptions@bsigroup.com

Knowledge Centre

Tel: +44 20 8996 7004

Email: knowledgecentre@bsigroup.com

Copyright & Licensing

Tel: +44 20 8996 7070

Email: copyright@bsigroup.com



...making excellence a habit.™