

INTERNATIONAL
STANDARD

ISO
24497-3

First edition
2007-11-01

**Non-destructive testing — Metal magnetic
memory —**

Part 3:
Inspection of welded joints

*Essais non destructifs — Mémoire magnétique des métaux —
Partie 3: Examen des assemblages soudés*



Reference number
ISO 24497-3:2007(E)

Contents		Page
Foreword		iv
1	Scope	1
2	Basic principles	1
3	Inspection conditions	2
4	Inspection devices	2
5	Inspection planning	3
6	Inspection procedure	4
7	Processing of results	5
Annex A (normative) Inspection report		7
Annex B (informative) Example of stress concentration zones defined by a device with digital indication of the magnetic field intensity		9
Annex C (informative) An example of stress concentration zones defined by the device having recorder and scanner		11

Foreword

ISO (the International Organization for Standardization) is a worldwide federation of national standards bodies (ISO member bodies). The work of preparing International Standards is normally carried out through ISO technical committees. Each member body interested in a subject for which a technical committee has been established has the right to be represented on that committee. International organizations, governmental and non-governmental, in liaison with ISO, also take part in the work. ISO collaborates closely with the International Electrotechnical Commission (IEC) on all matters of electrotechnical standardization.

International Standards are drafted in accordance with the rules given in the ISO/IEC Directives, Part 2.

The main task of technical committees is to prepare International Standards. Draft International Standards adopted by the technical committees are circulated to the member bodies for voting. Publication as an International Standard requires approval by at least 75 % of the member bodies casting a vote.

Attention is drawn to the possibility that some of the elements of this document may be the subject of patent rights. ISO shall not be held responsible for identifying any or all such patent rights.

ISO 24497-3 was prepared by the International Institute of Welding, Commission V, *Quality control and quality assurance of welded products*, recognized as an international standardizing body in the field of welding in accordance with Council Resolution 42/1999.

Requests for official interpretations of any aspect of this part of ISO 24497 should be directed to the ISO Central Secretariat, who will forward them to the IIW Secretariat for an official response.

ISO 24497 consists of the following parts, under the general title *Non-destructive testing — Metal magnetic memory*:

- *Part 1: Vocabulary*
- *Part 2: General requirements*
- *Part 3: Inspection of welded joints*

Non-destructive testing — Metal magnetic memory —

Part 3: Inspection of welded joints

1 Scope

This part of ISO 24497 specifies the general requirements for the application of the metal magnetic memory inspection method (MMM inspection) as a non-destructive testing method for quality assurance of welded joints of pressurized components.

This part of ISO 24497 may be applied to welded joints in any type of products, pipelines, vessels, equipment, and metal constructions, as agreed with the purchaser.

The terms and definitions for the process are contained in ISO 24497-1, and the general requirements of the process are in ISO 24497-2.

2 Basic principles

2.1 MMM inspection is based on measurement and analysis of the distribution of self-magnetic-leakage fields (SMLF) in the material of welded joints reflecting their technological history. Natural magnetization, induced during the welding process in the Earth's magnetic field, is used for the inspection.

2.2 MMM inspection permits the detection of mechanical stress concentration zones (SCZ) and gives recommendations for additional non-destructive inspections in critical zones of vessels, pipelines, equipment, and construction welded joints.

2.3 MMM inspection is complementary in its capability to other well-known non-destructive testing methods (ultrasonic inspection, magnetic particle inspection, liquid penetrant inspection, and hardness testing).

2.4 MMM inspection allows the testing of welded joints of any size and configuration (butt, tee, fillet, lap, edge, intermittent, etc.) regardless of weld material thickness on all types of ferromagnetic and austenitic steels and alloys, as well as on cast irons.

2.5 MMM inspection may be carried out on the original weld after construction, during operation, or after repair.

2.6 The following conditions can be found during MMM inspection:

- residual stress concentration zones caused by welding, and their distribution along the welded joint;
- zones of probable location of all types of micro- and macro-defects (pores, slag inclusions, discontinuities, cracks, ruptures).

Defect classification by magnetic parameters is carried out following special testing techniques for a specific welded joint.

2.7 MMM inspection can be used for inspection of the following:

- the degree of quality degradation of welds by defects, and presence of developing defects;
- the quality of welded joints at time of certification, choice, and optimization of welding technology.

2.8 The MMM inspection temperature range is from $-20\text{ }^{\circ}\text{C}$ to $+60\text{ }^{\circ}\text{C}$, limited only by the conditions of the operators' and inspection tool's normal operation.

2.9 Following MMM inspection, conventional non-destructive testing methods are applied in detected zones of maximal stress concentration and probable location of micro- and macro-defects.

3 Inspection conditions

3.1 Structures and components as inspection objects (IO) may be inspected using MMM both while operating under load and after releasing the working load.

3.2 No special surface preparation is required. It is recommended to remove insulation. In individual cases non-magnetic insulation is allowed during inspection. The maximum permissible insulation layer thickness shall be determined experimentally.

3.3 The permissible range of material thickness is defined by the descriptions of the techniques for specific inspection applications.

3.4 The limiting factors for MMM application are the following:

- the presence of artificial material magnetization;
- the presence of a foreign ferromagnetic product near the IO;
- the presence of an external magnetic field or an electric welding current flow closer than 1 m to the IO.

3.5 Acoustic noise or mechanical vibrations close to and at the IO do not influence the inspection results.

4 Inspection devices

4.1 For inspection of equipment using the MMM, specialized magnetometric devices are used. The standard procedure for the definition of stress concentration zones (SCZ) is described in the manual of the devices.

4.2 The principle of the operation of the specified devices is based on the registration of induced electrical voltage impulses in the flux-gate sensor coil, when this sensor is placed in the self-magnetic-leakage field (SMLF) in the near-surface area of the IO. Flux-gate sensors or other types, such as field meters or gradiometers, may be used as SMLF intensity measuring sensors.

4.3 The devices shall have a display for the graphic documentation of the used inspection parameters, a recording device with a microprocessor, a memory unit, and scanning devices realized by specialized sensors. The device shall be able to transfer the information to the computer, in order to produce inspection reports. The software for the processing of computerized inspection results should be provided with the device.

4.4 The specialized sensors shall be provided with the device. The individual sensor type to use is defined by the MMM technique and the requirements of the IO. The sensor should have not less than two channels: the measuring channel and a channel for the registration of the Earth's external magnetic field.

With the sensors, an electronic module for the amplification of the measured field and a sensor for measuring the inspected scan path length shall be supplied.

4.5 The admissible error of magnetic field intensity measurements is defined in the description of the individual techniques depending on the IO.

4.6 The devices shall have the following metrological characteristics:

- The relative error of the measured magnetic field for each measurement channel should not exceed ± 5 %.
- The relative error of the measured scan path length should not exceed ± 5 %.
- The measurement range of the devices should be not less $\pm 1\ 000$ A/m.
- The minimal scanning step (distance between two adjacent scanning points of the inspection) is 1 mm.
- The level of electronic noise caused by the processor and the microelectronic devices should not exceed ± 5 A/m.

4.7 The device shall have the possibility to define logfiles according to the user manual.

5 Inspection planning

5.1 Inspection planning includes the following basic stages:

- the analysis of the technical documentation of the object to be inspected and preparation of a checklist for the inspection;
- the adjustment and calibration of the devices and sensors, following the instructions given in the user manual;
- the selection of the individual sensors and the type of the inspection device;
- the segmentation of the IO into separate inspection areas and inspection units, according to the design features of the component and their documentation in an inspection logfile.

5.2 The technical documentation for the IO shall include the following:

- a description of the steel grade;
- a description of the operation modes of the objects and failure modes;
- a description of the design features of the component and the locations of welded joints.

6 Inspection procedure

6.1 Inspection of welded joints using a device with a digital indication of the magnetic field intensity

The sequence of scanning by the sensor of the device for the evaluation of several types of welded joints is shown in Figure 1.

Dimensions in millimetres

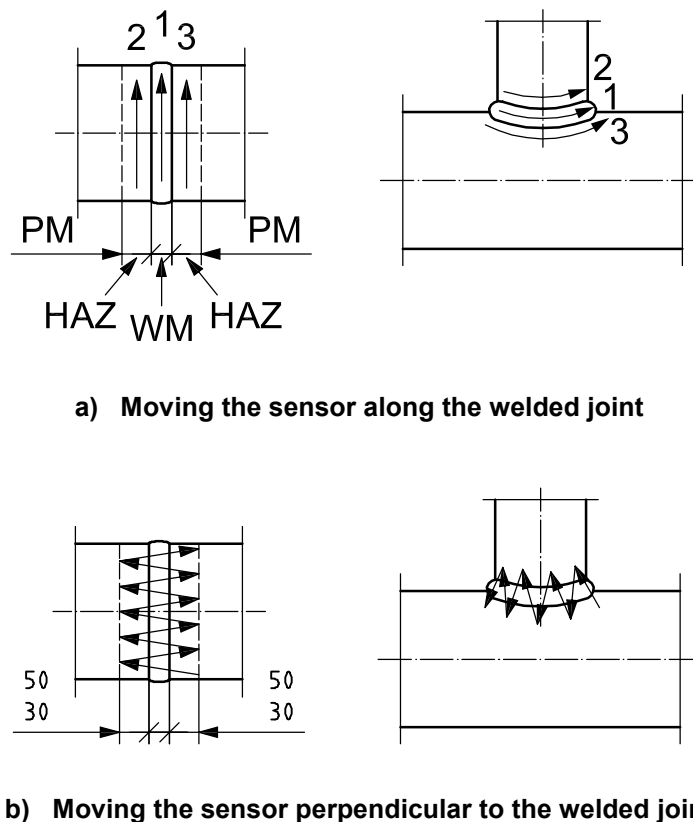

Key

1, 2, 3 inspection zones

WM weld material

HAZ heat-affected zone of welded joint

PM parent metal

Figure 1 — Scanning sequence by the sensor for the evaluation of several types of welded joints according to the residual magnetization of the material

The flux-gate sensor is placed perpendicular to the inspection surface and is moved by the operator manually and sequentially along the entire perimeter of a weld (separately along a weld material and along the heat-affected zones on both sides of the weld) and then perpendicular to the weld, with a distance from the edge of the weld of 30 mm to 50 mm on both sides of the parent material of a pipe.

The second operator records the inspection data in a logbook: magnetic field intensity (H_p , A/m) with plus or minus amplitudes. The discontinuous change of the sign and value of the H_p field indicates the concentration of residual stresses along the $H_p = 0$ line for a specific segment of the welded joint. These segments have to be marked by chalk or paint.

6.2 Inspection of welded joints using a device having display, recorder, and scanner

The inspection scheme for a butt-welded joint is shown in Figure 2. The inspection is carried out using a scanner consisting of four flux-gate transducers 1, 2, 3, 4 and a length-measuring device, built into the case of a trolley programmed to measure the length of an inspected inspection segment simultaneously with the measurement of values of magnetic field intensity, H_p . As shown in Figure 2, during inspection, transducers 1 and 3 are arranged in the heat-affected zones from both sides of a weld, and the transducer 2 is centred between them.

Before the beginning of the inspection for each measurement channel, the scanning step of measurement of the H_p field (value S in the set-up menu of the device) is set. The step of measurement is S or the distance between two adjacent scanning points of inspection, Δl_K , for each measurement channel. This value should not exceed the wall thickness of the material joined by the weld.

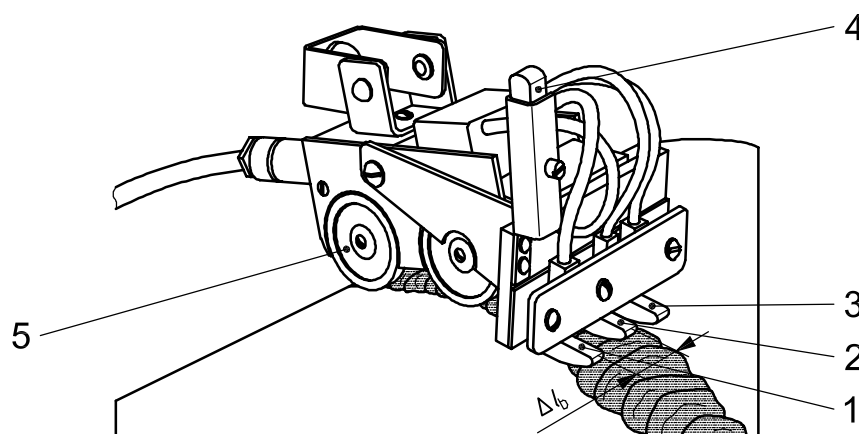

Key

- 1, 2, 3 flux-gate transducers of the scanner for the H_p field recording on a weld surface
- 4 flux-gate transducer for adjustment from an external magnetic field H_p
- 5 wheels of a drive of a length-meter

Δl_b base distance between adjacent transducers 1, 2, and 3

Figure 2 — Inspection of butt-welded joints of pipes using a four-channel sensor of the device

The base distance Δl_b between adjacent transducers 1, 2, and 3 is set in accordance with the dimensions of the welded joint and is recorded in the device memory after measurements (value b in the set-up menu of the device).

7 Processing of results

7.1 Using the results of MMM inspection, the following parameters are determined.

— The magnetic field gradient for each measurement channel $K_{in} = \frac{|\Delta H_p|}{\Delta l_K}$,

where

Δl_K is the distance between two adjacent points of the inspection.

- The magnetic field gradient between measurement channels $K_{b, in} = \frac{|\Delta H_p|}{\Delta l_b}$,

where

Δl_b is the basic distance between measurement channels.

- Median and maximum values $K_{med, in}$ and $K_{max, in}$ for each measurement channel and the basic distance between measurement channels.
- The magnetic parameter, m , describing a degree of a non-uniformity of the stress-strain state (SSS) and deformability of material in the stress concentration zone: $m = \frac{K_{max, in}}{K_{med, in}}$ (m is in the range 1,05 to 3,0 and more, depending on the welded joint quality).

All indicated magnetic parameters are determined using software supplied with the instrument.

7.2 The areas most susceptible to development of damage are the segments of a weld, on which the maximum H_p field values of different polarity between measurement channels (maximum value of $K_{b, in}$) are indicated and also the maximum value of the field gradient $K_{max, in}$ on any of the measurement channels. These segments correspond to stress concentration zones and welded joint defects. For detection of specific defects in stress concentration zones, additional inspection by conventional methods (ultrasonic inspection, radiographic inspection, etc.) is carried out.

7.3 From the results of the MMM inspection, the segments for the additional inspection by other non-destructive testing methods are identified.

7.4 In a SCZ with a value of the magnetic parameter $m \geq 2$, grinding (or material sampling) and the MMM-method shall be performed once more.

7.5 The results of the measurements are recorded and summarized as a conclusion, the testing logfile is an enclosure. The form of the test logfile is given in Annex A.

7.6 An example of inspection results for a device with a digital indication of the H_p magnetic field is shown in Annex B.

7.7 An example of inspection results for a device having a recorder and scanner is shown in Annex C. The parameters $K_{med, in}$, $K_{max, in}$, $K_{b, in}$, and m are calculated using the software delivered with the device.

Annex A (normative)

Inspection report

Name of enterprise _____

Name of equipment, type _____

Number of logbook, figure, scheme _____

TEST LOG No. _____

« _____ » _____

Name of the unit and inspection volume _____

Name of the technique or the guiding document _____

Inspection Data

No.	Placement of SCZ on the logbook (figure, scheme) of welded joint	Extremes (min/max) of H_p field (A/m) in SCZ	Values of inspection parameters				Results of inspection by other methods (SEM, US, magnetic particle inspection, etc.)	Note
			$K_{in\ all\ SCZ}$	$K_{max,\ in}$	$K_{med,\ in}$	m		

Conclusions

Recommended segments of SCZ

for additional inspection and repair _____

The inspection was carried out by _____

(position, surname and name)

Certificate No. and qualification of expert _____

Date of inspection: _____

Annex B (informative)

Example of stress concentration zones defined by a device with digital indication of the magnetic field intensity

An example of the distribution of the magnetic field H_p along the circumference of a butt-welded joint and in a zone of residual stress concentration (SC line) is shown on Figure B.1 a).

To define the stress intensity near to the SC line ($H_p = 0$ line) on an equal length l_K from both sides of the line [Figure B.1 b)] the value H_p is measured, and the gradient of the value of H_p along the length $2l_K$ is determined. This gradient, according to the formula $\frac{|\Delta H_p|}{2l_K}$, characterizes the magnetic coefficient of residual stress intensity (K_{in}). From the results of the K_{in} values for miscellaneous segments with stress concentration zones, the maximum values are determined.

For example, for the segment of welded joint [Figure B.1 b)] the K_{in} values for zones 1 and 2 are as follows:

$$\text{— For zone 1: } K_{in} = \frac{|-15 - 10|}{2l_K} = \frac{25 \text{ A/m}}{20 \text{ mm}} = 1,25 \frac{\text{A/m}}{\text{mm}} = 1\,250 \text{ A/m}^2$$

$$\text{— For zone 2: } K_{in} = \frac{|-30 - 15|}{2l_K} = \frac{45 \text{ A/m}}{20 \text{ mm}} = 2,25 \frac{\text{A/m}}{\text{mm}} = 2\,250 \text{ A/m}^2$$

It follows that the maximum value of K_{in} is in zone 2.

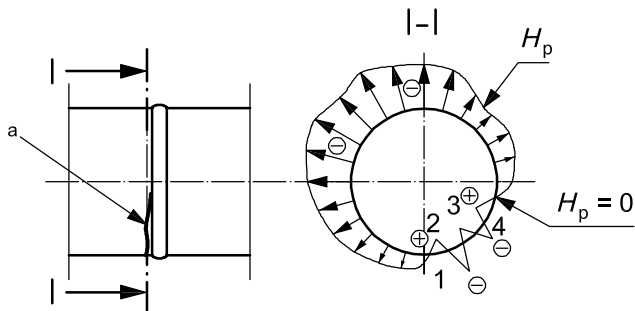

Key

a SC line ($H_p = 0$)

a) Diagram of H_p along the circumference of the welded joint with residual stress concentration SC (in 1-4 zones along $H_p = 0$ line)

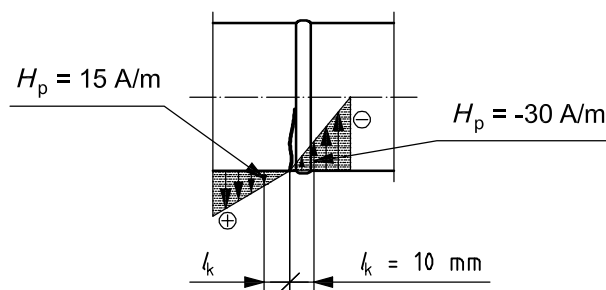

b) Diagram of H_p along the lower generatrix of the pipe in 1 and 2 zones of maximum stress concentration

Figure B.1 — Scheme of the magnetic field H_p distribution along the circumference of a butt-welded joint in a zone of residual stress concentration

Annex C (informative)

An example of stress concentration zones defined by the device having recorder and scanner

This example describes the inspection of a welded joint in a thick-walled boiler drum of a 110 MW power plant block.

The inspection results of the circular weld No. 1 of the boiler drum ($\varnothing 1\,800 \times 87$, the steel is similar to 16 GNM) of the 110 MW block are shown in Figure C.1.

The H_p field distribution along the circumference of the weld [see Figure C.1 a)] and in the scanning [see Figure C.1 b)] are documented, and also the zones of maximal SC are marked, in which the field H_p has a changing polarity and discontinuous nature with maximum dH/dx value. The calculation of $K_{1, med}$, $K_{2, med}$, \dots , $K_{j, med}$, $K_{f, b, med}$ was carried out only for the area of the weld with detected SC zones.

$$K_{1, med} = \frac{1}{n} \sum_{i=1}^n \frac{|\Delta H_p^i|}{\Delta l_K^i} = 2,35 \frac{\text{A/m}}{\text{mm}}$$

$$K_{2, med} = \frac{1}{n} \sum_{i=1}^n \frac{|\Delta H_p^i|}{\Delta l_K^i} = 3,4 \frac{\text{A/m}}{\text{mm}}$$

$$K_{b, med} = \frac{|\Delta H_p|}{\Delta l_b} = \frac{1}{n} \sum_{i=1}^n \frac{|\Delta H_p^i|}{\Delta l_b^i} = 1,7 \frac{\text{A/m}}{\text{mm}}$$

$$K_{1, max} = 3,5 \frac{\text{A/m}}{\text{mm}}$$

$$K_{2, max} = 6,2 \frac{\text{A/m}}{\text{mm}}$$

$$K_{b, max} = 3,5 \frac{\text{A/m}}{\text{mm}}$$

$$\frac{K_{1, max}}{K_{1, med}} = m_1 = \frac{3,5}{2,35} \cong 1,5; \quad \frac{K_{2, max}}{K_{2, med}} = m_2 = \frac{6,2}{3,4} \cong 1,85; \quad \frac{K_{b, max}}{K_{b, med}} = m_b = 2,1$$

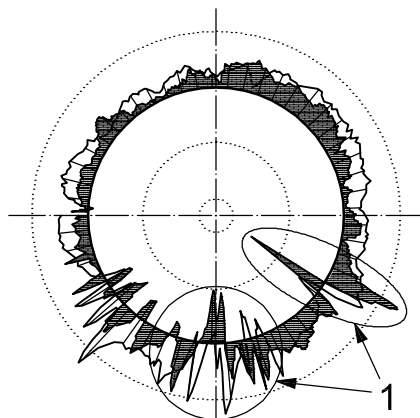

Key
1 SC_{max} zones

a) H_p field distribution along the circumference of the weld

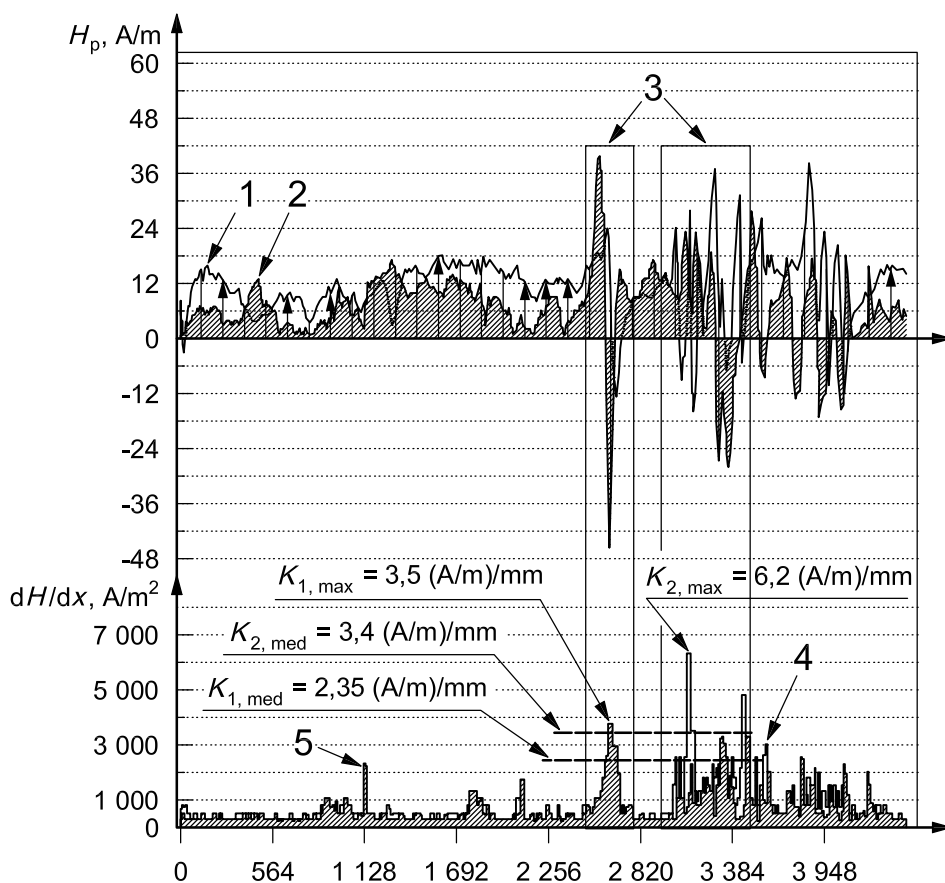

Key
1 H_p field distribution of H2 channel
2 H_p field distribution of H1 channel
3 SC_{max} zones
4 dH/dx graph of H2 channel
5 dH/dx graph of H1 channel

b) H_p field distribution in the scanning

Figure C.1 — H_p field distribution along welded joint No. 1 of a boiler drum in a 110 MW power plant block