

BS ISO 23794:2015



BSI Standards Publication

Rubber, vulcanized or thermoplastic — Abrasion testing — Guidance

bsi.

...making excellence a habit.™

National foreword

This British Standard is the UK implementation of ISO 23794:2015. It supersedes BS ISO 23794:2010 which is withdrawn.

The UK participation in its preparation was entrusted to Technical Committee PRI/22, Physical testing of rubber.

A list of organizations represented on this committee can be obtained on request to its secretary.

This publication does not purport to include all the necessary provisions of a contract. Users are responsible for its correct application.

© The British Standards Institution 2015.
Published by BSI Standards Limited 2015

ISBN 978 0 580 85596 2

ICS 83.060

Compliance with a British Standard cannot confer immunity from legal obligations.

This British Standard was published under the authority of the Standards Policy and Strategy Committee on 28 February 2015.

Amendments/corrigenda issued since publication

Date	Text affected
------	---------------

**Rubber, vulcanized or thermoplastic —
Abrasion testing — Guidance**

*Caoutchouc vulcanisé ou thermoplastique — Essais d'abrasion —
Lignes directrices*





COPYRIGHT PROTECTED DOCUMENT

© ISO 2015

All rights reserved. Unless otherwise specified, no part of this publication may be reproduced or utilized otherwise in any form or by any means, electronic or mechanical, including photocopying, or posting on the internet or an intranet, without prior written permission. Permission can be requested from either ISO at the address below or ISO's member body in the country of the requester.

ISO copyright office
Case postale 56 • CH-1211 Geneva 20
Tel. + 41 22 749 01 11
Fax + 41 22 749 09 47
E-mail copyright@iso.org
Web www.iso.org

Published in Switzerland

Contents

Page

Foreword	iv
1 Scope	1
2 Normative references	1
3 Terms and definitions	1
4 Wear mechanisms	2
5 Types of abrasion test	3
6 Abradants	3
7 Test conditions	4
7.1 Temperature.....	4
7.2 Degree and rate of slip.....	4
7.3 Contact pressure.....	4
7.4 Continuous/intermittent contact.....	5
7.5 Lubricants and contamination.....	5
8 Abrasion test apparatus	5
9 Reference materials	7
10 Test procedure	7
11 Expression of results	16
Bibliography	18

Foreword

ISO (the International Organization for Standardization) is a worldwide federation of national standards bodies (ISO member bodies). The work of preparing International Standards is normally carried out through ISO technical committees. Each member body interested in a subject for which a technical committee has been established has the right to be represented on that committee. International organizations, governmental and non-governmental, in liaison with ISO, also take part in the work. ISO collaborates closely with the International Electrotechnical Commission (IEC) on all matters of electrotechnical standardization.

The procedures used to develop this document and those intended for its further maintenance are described in the ISO/IEC Directives, Part 1. In particular the different approval criteria needed for the different types of ISO documents should be noted. This document was drafted in accordance with the editorial rules of the ISO/IEC Directives, Part 2 (see www.iso.org/directives).

Attention is drawn to the possibility that some of the elements of this document may be the subject of patent rights. ISO shall not be held responsible for identifying any or all such patent rights. Details of any patent rights identified during the development of the document will be in the Introduction and/or on the ISO list of patent declarations received (see www.iso.org/patents).

Any trade name used in this document is information given for the convenience of users and does not constitute an endorsement.

For an explanation on the meaning of ISO specific terms and expressions related to conformity assessment, as well as information about ISO's adherence to the WTO principles in the Technical Barriers to Trade (TBT) see the following URL: [Foreword - Supplementary information](#)

The committee responsible for this document is ISO/TC 45, *Rubber and rubber products*, Subcommittee SC 2, *Testing and analysis*.

This third edition cancels and replaces the second edition (ISO 23794:2010), which has been technically revised to include the blade abrader.

Rubber, vulcanized or thermoplastic — Abrasion testing — Guidance

WARNING 1 — Persons using this International Standard should be familiar with normal laboratory practice. This International Standard does not purport to address all of the safety problems, if any, associated with its use. It is the responsibility of the user to establish appropriate safety and health practices and to ensure compliance with any national regulatory conditions.

WARNING 2 — Certain procedures specified in this International Standard might involve the use or generation of substances, or the generation of waste, that could constitute a local environmental hazard. Reference should be made to appropriate documentation on safe handling and disposal after use.

1 Scope

This International Standard provides guidance on the determination of the abrasion resistance of vulcanized and thermoplastic rubbers. It covers both solid and loose abrasives.

The guidelines given are intended to assist in the selection of an appropriate test method and appropriate test conditions for evaluating a material and assessing its suitability for a product subject to abrasion. Factors influencing the correlation between laboratory abrasion testing and product performance are considered, but this International Standard is not concerned with wear tests developed for specific finished rubber products, for example, trailer tests for tyres.

2 Normative references

The following documents, in whole or in part, is normatively referenced in this document and is indispensable for its application. For dated references, only the edition cited applies. For undated references, the latest edition of the referenced document (including any amendments) applies.

ISO 23529, *Rubber — General procedures for preparing and conditioning test pieces for physical test methods*

3 Terms and definitions

For the purposes of this document, the following terms and definitions apply.

3.1

abrasion

loss of material from a surface due to frictional forces

[SOURCE: ISO 1382:2008]

3.2

abrasion resistance

resistance to wear resulting from mechanical action upon a surface

Note 1 to entry: Abrasion resistance is expressed by the abrasion resistance index.

[SOURCE: ISO 1382:2008]

3.3

abrasion resistance index

ratio of the loss in volume of a standard rubber to the loss in volume of a test rubber, measured under the same specified conditions and expressed as a percentage

[SOURCE: ISO 1382:2008]

3.4

relative volume loss

loss in volume of a test rubber due to abrasion by a specified abradant which will cause a reference rubber to lose a defined mass under the same conditions

4 Wear mechanisms

The mechanisms by which wear of rubber occurs when it is in moving contact with another material are complex, but the principal factors involved are cutting and fatigue. It is possible to categorize wear mechanisms in various ways and commonly distinction is made between

- abrasive wear,
- fatigue wear, and
- adhesive wear.

Additionally, wear by roll formation is sometimes considered as a separate mechanism.

Abrasive wear is caused by sharp asperities cutting the rubber.

Fatigue wear is caused by particles of rubber being detached as a result of dynamic stressing on a localized scale.

Adhesive wear is the transfer of rubber to another surface as a result of adhesive forces between the two surfaces.

Wear by roll formation is where there is progressive tearing of a layer of rubber which forms a roll.

There can also be corrosive wear due to direct chemical attack on the surface.

The term erosive wear is sometimes used for the action of particles in a liquid stream.

In any particular wear situation, more than one mechanism is usually involved, but one might predominate. Abrasive wear requires hard, sharp cutting edges, and high friction. Fatigue abrasion occurs with smooth or rough but blunt surfaces and does not need high friction. Adhesive wear is much less common, but can occur on smooth surfaces. Roll formation requires high friction and relatively poor tear strength. Roll formation results in a characteristic abrasion pattern of ridges and grooves at right angles to the direction of movement.

Abrasive wear or roll formation results in much more rapid wear than fatigue processes. The mechanism and hence the rate of wear can change, perhaps quite suddenly, with the conditions, such as contact pressure, speed, and temperature. In any practical circumstances, the mechanisms can be complex and critically dependent on the conditions. Consequently, the critical factor as regards testing is that the test conditions have to essentially reproduce the service conditions if a good correlation is to be obtained. Even a comparison between two rubbers might be invalid if the dominant mechanism is different in testing and in service. The range of conditions encountered in applications such as tyres is so complex, that they cannot be matched by a single test.

It follows that there cannot be a universal standard abrasion test method for rubber, and the test method and test conditions have to be chosen to suit the end application. Also, great care has to be taken if the test is intended to provide a significant degree of acceleration.

5 Types of abrasion test

Many abrasion testing machines have been devised and standardized at national level for use with rubber. The majority of rubber tests involve a relatively sharp abradant and were devised for use with tyre tread materials.

Abrasion tests can be divided into two main types: those using a loose abradant and those using a solid abradant.

A loose abrasive powder can be used rather in the manner of a shot-blasting machine as a logical way of simulating the action of sand or similar abradants impinging on the rubber in service. A loose abradant can also be used between two sliding surfaces. Conveyor belts or tank linings are examples of products subject to abrasion by loose materials. A car tyre is an example of the situation where there is a combination of abrasion against a solid rough abradant, the road, and abrasion against a free-flowing abradant in the form of grit particles. This situation can also occur in testing as a result of the generation of wear debris from a solid abradant.

Solid abradants can consist of almost anything, but the most common are: abrasive wheels (vitreous or resilient), abrasive papers or cloths, and metal "knives". The majority of wear situations involve the rubber moving in contact with another solid material.

Distinctions can be made on the basis of the geometry by which the test piece and abradant are rubbed together. Many geometries are possible, and some common configurations are shown in [Figure 1](#) to [Figure 9](#):

[Figure 1](#): The test piece reciprocates linearly against a sheet of abradant (or alternatively a strip of abradant can be moved past a stationary test piece).

[Figure 2](#): The abradant is a rotating disc with the test piece held against it (or vice versa).

[Figure 3](#): Both abradant and test piece are in the form of a wheel, either of which can be the driven member.

[Figure 4](#): The abradant wheel is driven by a flat rotating test piece.

[Figure 5](#): Both the test piece and the abradant are rotating.

[Figure 6](#): The test piece is held against a rotating drum.

[Figure 7](#): The test piece revolves in contact with metal knives.

[Figure 8](#): Test pieces are tumbled together with abrasive particles inside a hollow rotating cylinder.

[Figure 9](#): Single metal knife is held against a rotating tube test piece.

If the abrasion is unidirectional, abrasion patterns will develop which can markedly affect abrasion loss.

6 Abradants

Abradants can be classified into the following types:

- abrasive wheels;
- papers and cloths;
- metal knives;
- smooth surfaces;
- loose abradants.

The abrasive wheel is probably the most convenient abradant because of its low cost and mechanical stability, and also, by simple refacing, a consistent surface can be maintained. Wheels are characterized by the nature of the abrading particles, their size and sharpness, the structure of the wheel, and the

manner in which the abrasive is bonded (either resilient or vitreous). It follows that a very wide range of abrasive properties is possible.

Abrasive papers and cloths are inexpensive and easy to use, but deteriorate in cutting power rather quickly. They are characterized by the nature of the abrading particles and their size and sharpness.

Metal “knives” can have various geometries, including the form of a mesh and a raised pattern on a wheel. The main characteristic is the sharpness (radius) of the edges in contact with the rubber, and there can be some difficulty maintaining a reproducible sharpness.

Smooth surfaces are characterized by their degree of smoothness and the material, which defines the level of friction.

Loose abrasives are commonly particles of the same material as is used to form abrasive wheels or papers, and are characterized by their size and sharpness.

The choice of abrasive should be made primarily to give the best correlation with service conditions, but it is also necessary for the abrasive to be available in a convenient form and for its production to be reproducible.

As a consequence of these considerations, abrasive wheels and papers or cloths predominate where cutting by sharp asperities is to be simulated. It is still necessary to select an appropriate asperity size and sharpness. Materials such as textiles and metal plates are more appropriate for other applications. Smoother materials generally abrade relatively slowly and, if conditions are accelerated, give rise to an excessive temperature rise at the sliding surfaces. Because of these difficulties, abrasive wheels and papers are frequently used for convenience in situations where they are inappropriate for assessment of in-service performance.

7 Test conditions

7.1 Temperature

Although temperature has a large effect on wear rate and is one of the important factors in obtaining correlation between laboratory and service conditions, it is extremely difficult to control the temperature during testing. Abrasion tests are normally carried out at standard laboratory temperature. However, it is the temperature of the contact surfaces which is of importance rather than the ambient temperature, and the surface temperature reached is dependent on several experimental factors as outlined in [7.2](#) to [7.5](#).

7.2 Degree and rate of slip

With any geometry involving a fixed abrasive, there is relative movement or slip between the abrasive and the test piece, and the degree of slip is a critical factor in determining the wear rate. In [Figure 1](#) and [Figure 6](#), there is 100 % slip, and the rate of slip is the same as the rate of movement between abrasive and test piece, whereas in [Figure 3](#), the degree of slip can be varied by changing the angle between the wheels. In [Figure 2](#), [Figure 4](#), and [Figure 5](#), the rate of slip will depend on the distance of the test piece from the centreline. In all cases, the rate will depend on the speed of the driven member. An increase in the rate of slip will also increase the amount of heat generated and hence the temperature.

7.3 Contact pressure

The contact pressure between the test piece and abrasive is another critical factor in determining the wear rate. Under some conditions, the wear rate might be approximately proportional to the pressure, but abrupt changes will occur if, with changing pressure, the abrasion mechanism changes. Such a change can be because of a large rise in temperature.

Rather than consider contact pressure and degree of slip separately, it has been proposed that the power consumed in moving the rubber over the abrasive should be used as a measure of the severity of an

abrasion test. The power used will depend on the friction between the surfaces and will determine the rate of temperature rise.

7.4 Continuous/intermittent contact

An important difference between the types of apparatus shown in, for example, [Figure 1](#) and [Figure 4](#) is that, in the first case, the test piece is continuously and totally in contact with the abrasant and there is no chance of the heat generated at the contact surfaces being dissipated.

7.5 Lubricants and contamination

Any change in the nature of the contact surfaces will affect the rate of wear, and this includes changes in the abrasant and the test piece as the wear process proceeds. Additionally, there can be deliberate addition of another material between the contact surfaces, accidental contamination, debris from the abrasant, and debris from the test piece.

Introduction of a particulate material between the contact surfaces can be made to simulate service conditions, such as a car tyre running on a dusty road. Similarly, a lubricant such as water can be introduced. Relatively few types of apparatus are capable of operating under these conditions.

It is common practice to remove wear debris by continuously brushing the test piece or by the use of air jets. In the latter case, care has to be taken to ensure that the air supply is not contaminated with oil or water from the compressor. Clogging or smearing of the abrasant is a common problem with abrasive wheels and papers, and its occurrence will invalidate the test. It is normally caused by a high temperature at the contact surfaces and, although the problem can sometimes be reduced by introducing a powder between the surfaces, it should be treated as an indication that the test conditions are not suitable. If high temperatures are experienced in service, a test method in which new abrasant is continually used should be chosen.

If correlation between laboratory tests and service conditions is required, the test conditions will have to be chosen extremely carefully to match those found in the application concerned.

8 Abrasion test apparatus

A large number of abrasion testers have been developed, and the following list is not exhaustive, but covers those of greatest significance in the rubber and plastics industries (the main features of each are presented in [Table 1](#)).

- **Akron:** Wheel-on-wheel geometry, notable for the ability to vary the degree of slip by changing the relative angle of the wheels.

NOTE 1 An example of the use of this method can be found in BS 903-A9, which is now withdrawn.

- **Blade abrader:** Single knife blade under a constant normal load is in contact with the flat surface of a rotating cylindrical tube test piece.

- **DuPont (Grasselli):** Pair of small, flat-faced moulded test pieces on a rotating abrasive paper disc.

NOTE 2 An example of the use of this method can be found in BS 903-A9, which is now withdrawn.

- **Frick Taber:** Abrasive wheels on disc test piece with additional flow of abrasive powder. Noted for simulating wear of flooring.

NOTE 3 An example of the use of this method can be found in EN 660-2.

- **Laboratory Abrasion Tester 100 (System Dr Grosch^[24]):** Sophisticated computer-controlled apparatus, allowing variation of several parameters. Wheel-on-disc geometry.

- **Lambourn (Dunlop):** Both test piece and abrasive wheel are driven, slip being produced by eddy current braking.

— **Improved Lambourn:** Significantly improved design. Test piece and abrasive wheel driven independently.

— **Martindale:** Disc test piece on cloth abrasive disc. The pattern of relative movement forms a Lissajous figure giving multidirectional wear. A standard method for coated fabrics.

NOTE 4 An example of the use of this method for coated fabrics can be found in ISO 5470-2.

— **NBS (Footwear abrader):** Small square test piece in contact with a revolving drum covered with abrasive paper. Used particularly for footwear compounds.

NOTE 5 An example of the use of this method, primarily for shoe soles and heels, can be found in ASTM D1630.

— **Pico:** Disc test piece rotated in contact with a pair of tungsten knives supplied with a uniform flow of dusting powder.

NOTE 6 An example of the use of this method can be found in ASTM D2228.

— **Rotating cylindrical drum (DIN, Conti):** Small disc test piece traverses rotating cylinder covered with abrasive paper which gives large abradant/test piece area.

NOTE 7 An example of the use of this method can be found in ISO 4649.

— **Rotating cylindrical mill:** A number of designs involving test pieces (usually discs) and particulate abrasive being tumbled together inside a rotating hollow drum. The motion simulates the action of free-flowing abrasive materials.

— **Schiefer (WIRA):** The test piece and abradant are two discs arranged as shown in [Figure 5](#). The movement produces multidirectional abrasion. Various abradants may be used, including serrated metal surfaces.

— **Taber:** A pair of abrasive wheels is in contact with a driven flat-disc test piece. The force on the wheels and the nature of the abradant can easily be varied and the test can be carried out in the presence of liquids.

NOTE 8 An example of the use of this method for coated fabrics can be found in ISO 5470-1.

Table 1 — Summary of types of abrasion apparatus

	Test piece	Abradant	Motion	Slip	Speed	Contact	Reference
Akron	Wheel	Abrasive wheel	Test piece driven	Variable	0,2 m/s to 0,35 m/s	Intermittent	Figure 3
Blade abrader	Cylindrical tube	Knife	Test piece rotates	100 %	Variable	Continuous	Figure 9
DuPont	Moulded or cut from sheet	Abrasive paper	Abrasive paper rotates	100 %	0,19 m/s to 0,3 m/s	Continuous	Figure 2
Frick Taber	Flat disc	Wheel + powder	Test piece rotates	100 %	0,25 m/s	Intermittent	Figure 4
LAT 100	Wheel	Abrasive disc	Disc rotates	Variable	Variable	Intermittent	Figure 4
Lambourne	Wheel	Abrasive wheel	Test piece/ abradant driven	Variable	0,21 m/s	Intermittent	Figure 4
Improved Lambourne	Wheel	Abrasive wheel	Test piece/ abradant driven	Variable	0,15 m/s to 3,6 m/s	Intermittent	Figure 3
Martindale	Disc	Various	Test piece driven in pattern	100 %	Varies	Continuous	Modification of Figure 1

Table 1 (continued)

	Test piece	Abradant	Motion	Slip	Speed	Contact	Reference
NBS	Square cut from sheet	Abrasive paper	Rotating drum	100 %	0,3 m/s to 0,4 m/s	Continuous	Figure 6
Pico	Disc	Tungsten knives	Test piece rotates	100 %	1,7 m/s to 5,3 m/s	Continuous	Figure 7
DIN	Disc	Abrasive paper	Rotating drum	100 %	0,31 m/s	Continuous	Figure 6
Mill	Disc	Abrasive particles	Tumbled in drum	NA	NA	Continuous	Figure 8
Schiefer	Disc	Various	Test piece/ abradant driven	100 %	Varies	Continuous	Figure 5
Taber	Flat disc	Various wheels	Disc rotates	100 %	0,045 m/s	Intermittent	Figure 4

9 Reference materials

Because of the difficulty in ensuring reproducibility of the abradant and/or test conditions, it is common practice to use a reference material against which results on the test material can be normalized.

Some workers prefer to use a standard rubber to normalize or certify the abradant. This is most useful when the abradant is certified by one source only, but does not enable corrections to be made for machine variations and ageing of the abradant.

The alternative, or additional, approach is to refer results on the test material to results obtained at the same time on a reference rubber, with the objective of eliminating variability due to differences between nominally identical machines and abrasives.

The drawback to either approach is the difficulty in producing an accurately reproducible reference rubber. It might be difficult to decide whether it is the abradant or the reference rubber that is the most stable and reproducible.

A reference rubber can be produced and certified by one source, be produced locally to a given formulation or specification, or be an in-house or user-defined standard representative of the type of compound being evaluated.

The most common type of reference rubber is based on a tyre tread compound, but shoe-sole type material is also widely used. Reference rubbers are specified in some specific abrasion test method standards, but no generally applicable reference materials have been established.

A material other than rubber could be used as a reference material, and could be more suitable in terms of reproducibility. A very soft metal and a plastic have been suggested, but no such material is in common use.

10 Test procedure

The main objective in selecting the test method and test conditions for a particular application is to achieve correlation with service conditions. Good correlation is only possible if the abradant and test conditions reproduce the essential conditions and, particularly, the abrasion mechanisms of service. Where service conditions are not well defined, it will be advisable to carry out tests with a range of abrasives and test conditions.

In practice, good correlation is often extremely difficult or impossible to achieve because of the complexity of the wear mechanisms and the multiple climatic conditions in service.

Even for purely quality control purposes, it is necessary for the abrasant and conditions to be chosen so as to be similar to those in service, although it will generally be sufficient to test with one abrasant and one set of defined test conditions.

The abrasion pattern is a good, although not foolproof, indication of the wear mechanism, and examination of the worn surfaces of both the product and test pieces can show how well the service conditions have been matched in the laboratory.

Even if there is no quantitative correlation, valuable results can be obtained if the test produces the same ranking of materials as in service. For example, if the wear resistance depends on the hardness, resilience or coefficient of friction, the test should show a similar dependence. Fatigue wear can sometimes be changed by the type of anti-degradant present in the rubber under both test and service conditions.

In seeking correlation, consideration should be given to factors other than the test conditions and wear mechanism. These include the effect of product bulk, the role of inflation where applicable, differences in the state of cure between the product and test pieces, and the effect of ageing of the product. Thus, it might sometimes be appropriate to examine the effect of cure or ageing on test performance for closer correlations.

The general test procedure should follow a particular test method standard or the apparatus manufacturer's instructions. Attention is drawn to ISO 23529 for conditioning of test pieces, determination of dimensions and preparation of test pieces, which should be followed as appropriate.

For some methods, it is advisable to make trial runs to establish suitable test conditions.

It is necessary to resurface or renew the abrasant and to plan the order in which materials are tested to minimize the effects of changes in the abrasant with time. Ideally, a new abrasant would be used for each test, but the frequency at which resurfacing or renewal is necessary will depend on the particular abrasant and the nature of the materials tested. A common practice is to test a reference material at intervals between the testing of the materials under study and to run repeat test pieces of a series of materials in reverse order.

Most methods are based on determining the difference in mass of the test piece before and after abrasion. Care will have to be taken that erroneous results are not obtained where microscopic examination shows that material has been scraped from the surface but remains attached to the test piece.

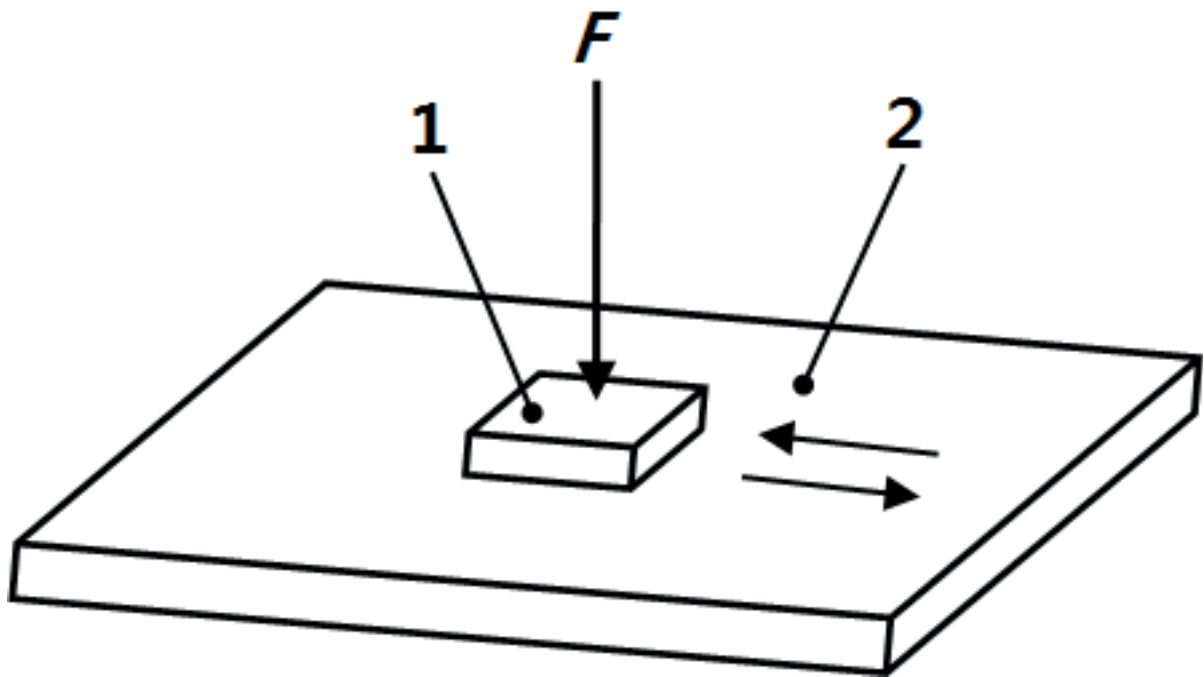

Key

- 1 test piece
- 2 abrasant

Figure 1 — Test piece reciprocating linearly against a sheet of abrasant

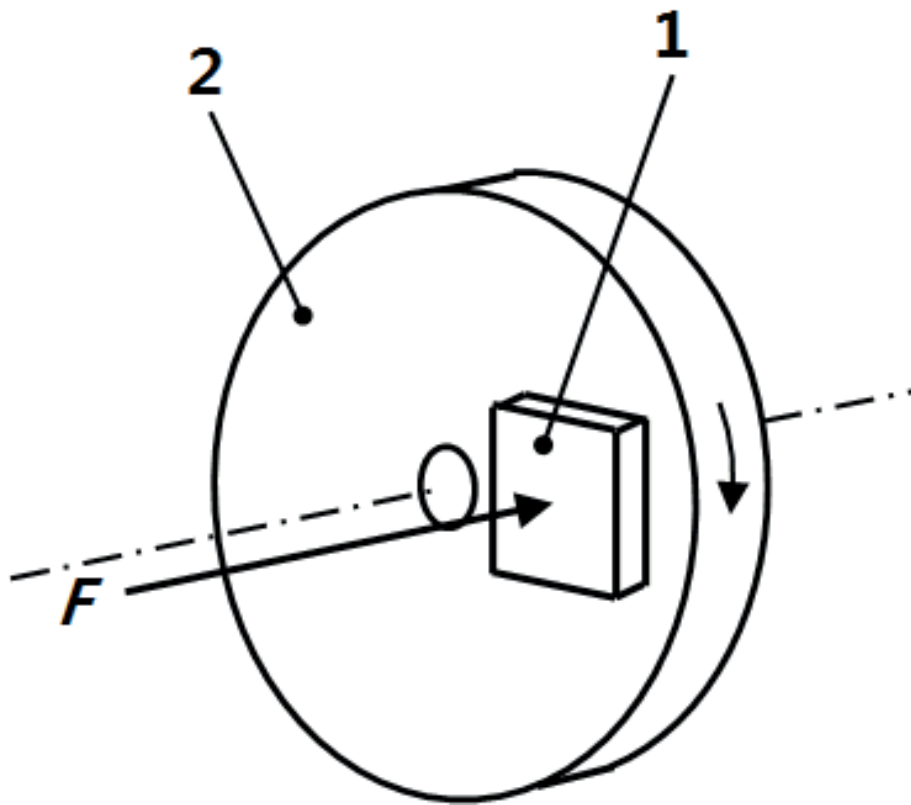

Key

- 1 test piece
- 2 abrasant

Figure 2 — Test piece held against a rotating disc of abrasant

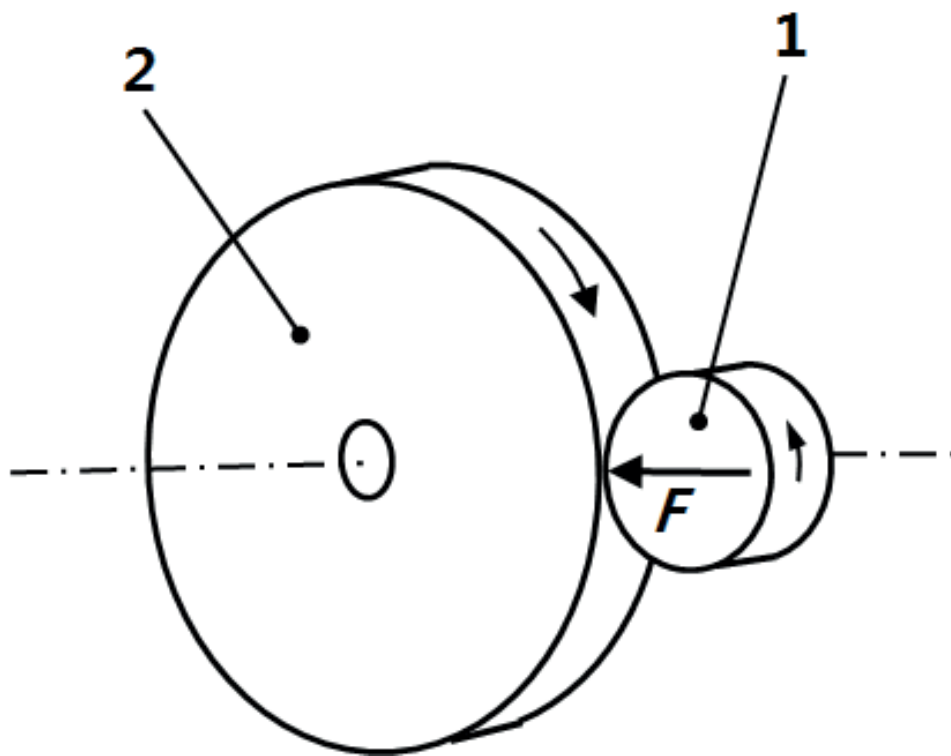

Key

- 1 test piece
- 2 abrillant

Figure 3 — Test piece and abrillant in the form of wheels either of which could be driven

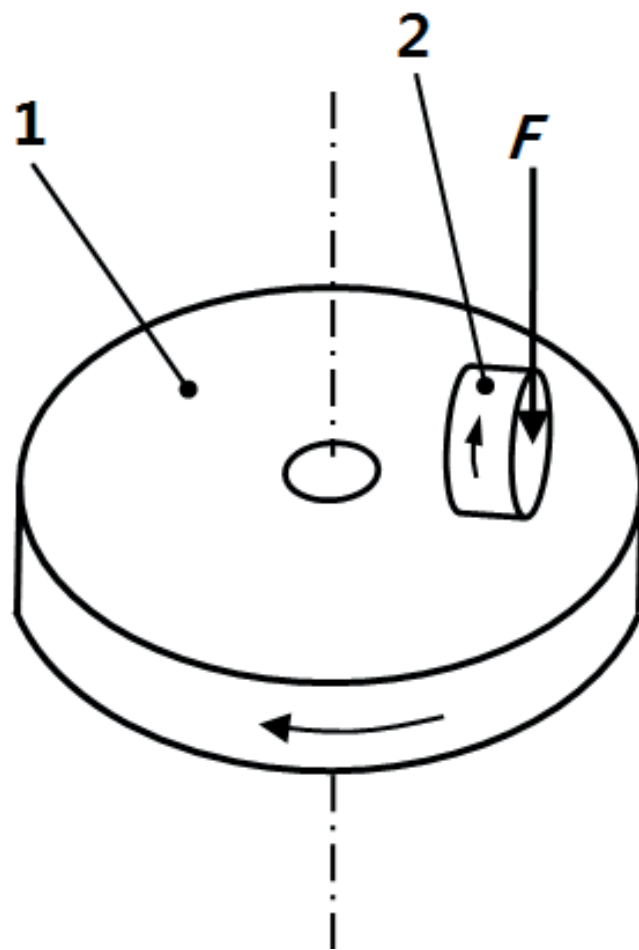

Key

- 1 test piece
- 2 abrasant

Figure 4 — Rotating test piece driving, or driven by, the abrasant wheel(s)

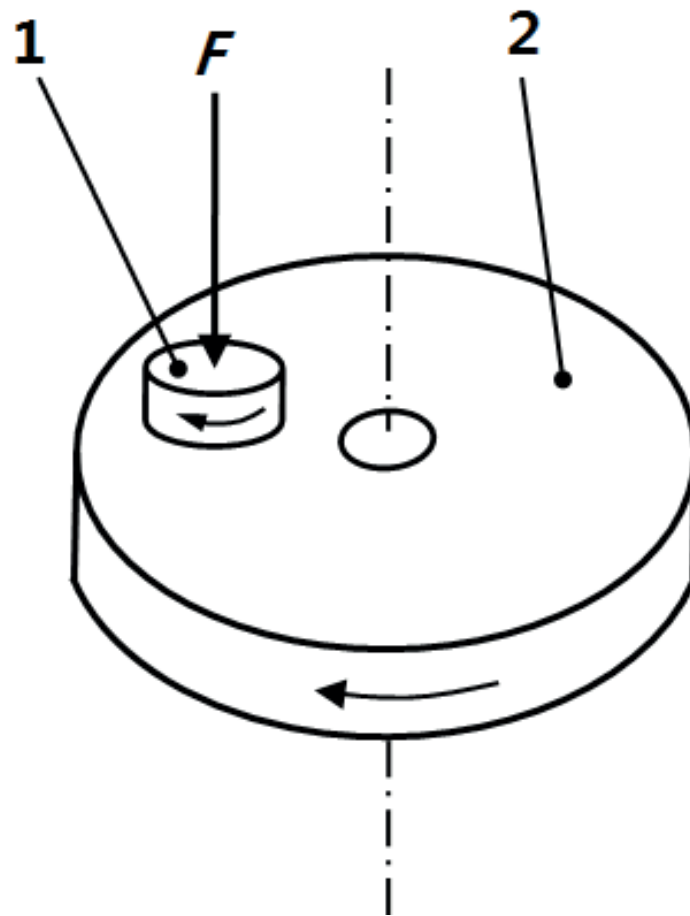

Key

- 1 test piece
- 2 abrasant

Figure 5 — Rotating test piece held against a rotating abrasant disc

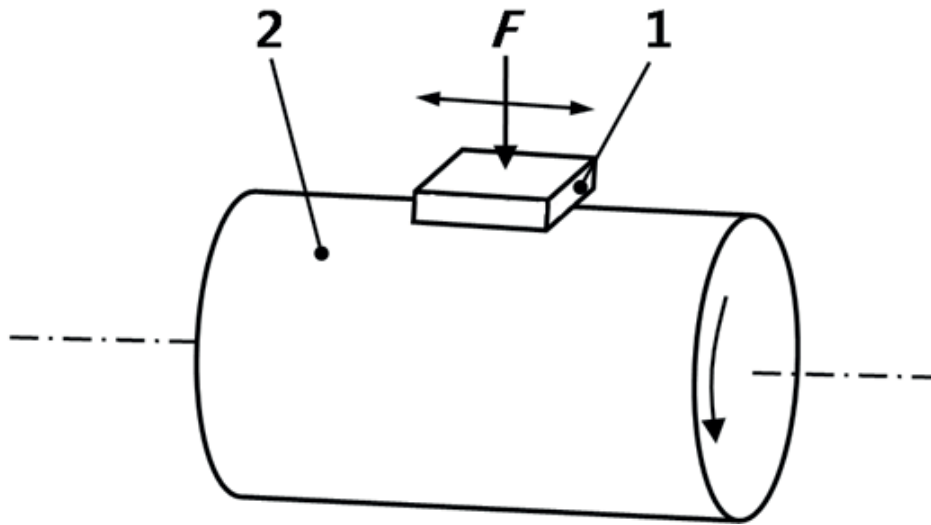

Key

- 1 test piece
- 2 abrasant

Figure 6 — Test piece held against a rotating abrasant drum

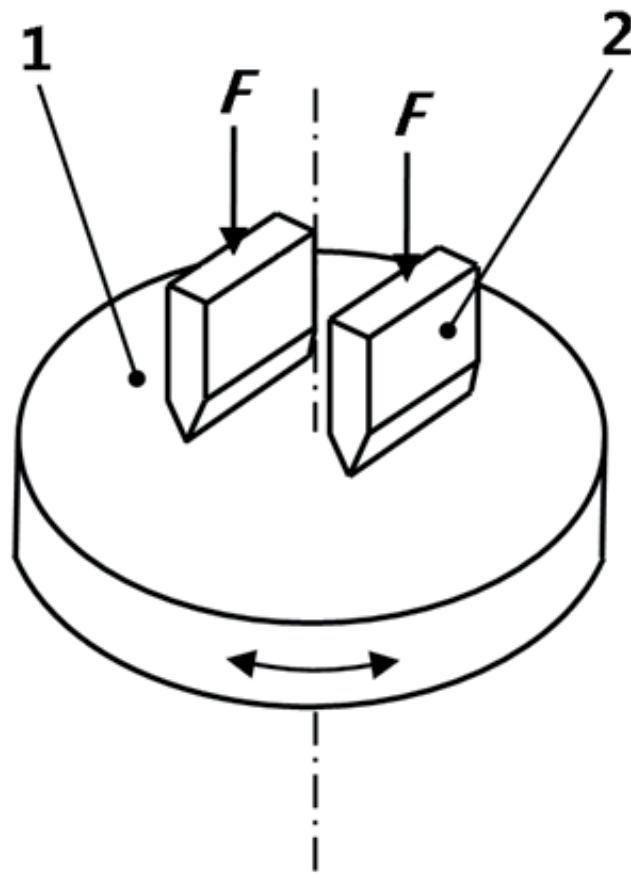

Key

- 1 test piece
- 2 abrasant

Figure 7 — Knife-type abrasant held against test piece in the form of a rotating disc

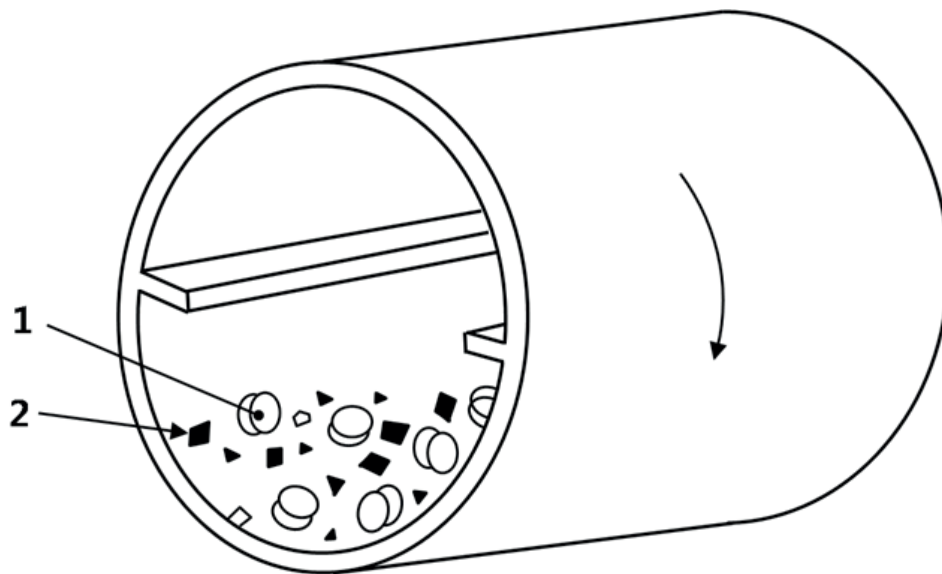

Key

- 1 test piece
- 2 abrasant

Figure 8 — Test pieces and abrasants inside a rotating drum

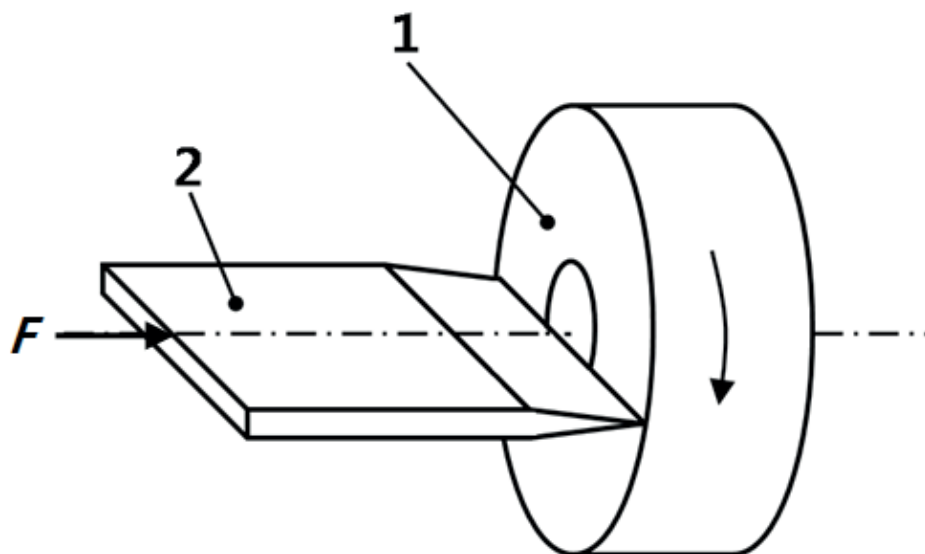

Key

- 1 test piece
- 2 abrasant

Figure 9 — Knife-type abrasant held against a rotating cylindrical tube test piece

11 Expression of results

In standard abrasion tests, it is usually mass loss which is the parameter measured, although in certain cases, the change in test piece thickness is more convenient. Because it is the amount of material lost which matters, it is usual to convert the mass loss to a volume loss by dividing by the density. The volume loss can be expressed as the loss per unit distance travelled over the abrasant, loss per 1 000 revolutions

of the apparatus, or loss per some other measure of length or time. A less usual practice is to express the result as the loss in volume per unit of energy consumed in causing abrasion, which is sometimes referred to as *abradability* and can be linked to the relative sliding speed through the Williams Landel Ferry (WLF) relationship. The loss in volume can also be calculated per unit surface area to give a specific wear rate.

Whatever measure is used to represent the loss, the rate of wear might not be constant because of inhomogeneity of the test piece, changes in the test piece surface or gradual changes in the nature of the abradant. To investigate the test piece effects, wear rate can be plotted against the number of cycles or the distance travelled. Abradant effects can be compensated for as discussed in [Clause 10](#).

The abrasion resistance can be calculated as the reciprocal of the loss in volume.

If a reference material has been used to normalize the abradant, the relative volume loss, V_{RVL} , is calculated from:

$$V_{RVL} = \frac{V_{\text{test}} \times V_{\text{const}}}{V_{\text{ref}}} \quad (1)$$

where

V_{test} is the loss in volume of the test rubber;

V_{const} is the defined loss in volume of the reference rubber;

V_{ref} is the measured loss in volume of the reference rubber.

If the loss in volume is to be normalized with respect to a reference material, the abrasion resistance index, V_{ARI} , is calculated from:

$$V_{ARI} = \frac{V_{\text{ref}}}{V_{\text{test}}} \times 100 \quad (2)$$

None of the measures of abrasion resistance given above are fundamental properties of the rubber but relate only to the specific conditions of test.

If the loss due to abrasion is measured as a function of parameters such as speed, temperature, degree of slip, energy consumed, etc., it might be possible to perform a multiple correlation analysis and obtain a composite measure of abrasion resistance. This is not possible, or is at least extremely tedious, with most abrasion apparatus, but can be achieved automatically with the Laboratory Abrasion Tester 100 (System Dr Grosch^[24]).

Bibliography

- [1] ISO 1382:2008, *Rubber — Vocabulary*
- [2] BS 903 Part A9, *Physical testing of rubber — Determination of abrasion resistance*
- [3] EN 660-2, *Resilient floor coverings — Determination of wear resistance — Part 2: Frick-Taber test*
- [4] ISO 5470-2, *Rubber- or plastics-coated fabrics — Determination of abrasion resistance — Part 2: Martindale abrader*
- [5] ASTM D1630, *Standard Test Method for Rubber Property — Abrasion Resistance (Footwear Abrader)*
- [6] ASTM D2228, *Standard Test Method for Rubber Property — Relative Abrasion Resistance by Pico Abrader Method*
- [7] ISO 4649, *Rubber, vulcanized or thermoplastic — Determination of abrasion resistance using a rotating cylindrical drum device*
- [8] ISO 5470-1, *Rubber- or plastics-coated fabrics — Determination of abrasion resistance — Part 1: Taber abrader*
- [9] KRAGELSKII I.V. ed. *Friction and Wear*. John Wiley and Sons, 1965
- [10] SCHALLAMACH A. *Friction and abrasion of rubber*. *Wear*. 1958, **1** p. 384
- [11] SCHALLAMACH A. *Abrasion of rubber I*. *Int. Polym. Sci. Tech.* 1979, **6** (1) p. T44
- [12] SCHALLAMACH A. *Abrasion of rubber II*. *Int. Polym. Sci. Tech.* 1979, **6** (1) p. T63
- [13] SCHALLAMACH A. *Progress in Rubber Technology*. Elsevier, 1984
- [14] LANCASTER J.K. *Abrasive wear of polymers*. *Wear*. 1969, **14** p. 223
- [15] LANCASTER J.K. *Basic mechanisms of friction and wear of polymers*, *Plastics and Polymers*, Dec. 1973
- [16] UCHIYAMA Y., & TANAKA K. *Junkatsu*. 1975, **20** (1) p. 28 [in Japanese]
- [17] GILTROW J.P. *A relationship between abrasive wear and the cohesive energy of materials*. *Wear*. 1970, **15** p. 71
- [18] UCHIYAMA Y. *Nippon Gomu Kyokai shi fil.* 1998, pp. 315. [in Japanese]
- [19] JAMES D.I. ed. *Abrasion of Rubber*. Maclaren, London, 1967
- [20] KRAGELSKII I.V., & NEPOMNYASHCHI E.F. *Fatigue wear under elastic contact conditions*. *Wear*. 1965, **8** p. 303
- [21] UCHIYAMA Y. *Nippon Gomu Kyokai shi fil.* 1985, **2**, p. 47 [in Japanese]
- [22] MUHR A.H., & ROBERTS A.D. *Wear*. 1992, **158** p. 213
- [23] BROWN R.P. *Physical Testing of Rubber*. Springer, New York, 2006
- [24] GROSCH K.A. *A new method to evaluate traction and wear properties of tire tread compounds*, ACS Rubber Division Meeting, Cleveland OH, October 1997
- [25] NAH C., CHO J., KAANG S. *An improved test method of abrasion of rubber in a blade abrader*. *Polym. Test.* 1998, **17** p. 11

British Standards Institution (BSI)

BSI is the national body responsible for preparing British Standards and other standards-related publications, information and services.

BSI is incorporated by Royal Charter. British Standards and other standardization products are published by BSI Standards Limited.

About us

We bring together business, industry, government, consumers, innovators and others to shape their combined experience and expertise into standards-based solutions.

The knowledge embodied in our standards has been carefully assembled in a dependable format and refined through our open consultation process. Organizations of all sizes and across all sectors choose standards to help them achieve their goals.

Information on standards

We can provide you with the knowledge that your organization needs to succeed. Find out more about British Standards by visiting our website at bsigroup.com/standards or contacting our Customer Services team or Knowledge Centre.

Buying standards

You can buy and download PDF versions of BSI publications, including British and adopted European and international standards, through our website at bsigroup.com/shop, where hard copies can also be purchased.

If you need international and foreign standards from other Standards Development Organizations, hard copies can be ordered from our Customer Services team.

Subscriptions

Our range of subscription services are designed to make using standards easier for you. For further information on our subscription products go to bsigroup.com/subscriptions.

With **British Standards Online (BSOL)** you'll have instant access to over 55,000 British and adopted European and international standards from your desktop. It's available 24/7 and is refreshed daily so you'll always be up to date.

You can keep in touch with standards developments and receive substantial discounts on the purchase price of standards, both in single copy and subscription format, by becoming a **BSI Subscribing Member**.

PLUS is an updating service exclusive to BSI Subscribing Members. You will automatically receive the latest hard copy of your standards when they're revised or replaced.

To find out more about becoming a BSI Subscribing Member and the benefits of membership, please visit bsigroup.com/shop.

With a **Multi-User Network Licence (MUNL)** you are able to host standards publications on your intranet. Licences can cover as few or as many users as you wish. With updates supplied as soon as they're available, you can be sure your documentation is current. For further information, email bsmusales@bsigroup.com.

BSI Group Headquarters

389 Chiswick High Road London W4 4AL UK

Revisions

Our British Standards and other publications are updated by amendment or revision.

We continually improve the quality of our products and services to benefit your business. If you find an inaccuracy or ambiguity within a British Standard or other BSI publication please inform the Knowledge Centre.

Copyright

All the data, software and documentation set out in all British Standards and other BSI publications are the property of and copyrighted by BSI, or some person or entity that owns copyright in the information used (such as the international standardization bodies) and has formally licensed such information to BSI for commercial publication and use. Except as permitted under the Copyright, Designs and Patents Act 1988 no extract may be reproduced, stored in a retrieval system or transmitted in any form or by any means – electronic, photocopying, recording or otherwise – without prior written permission from BSI. Details and advice can be obtained from the Copyright & Licensing Department.

Useful Contacts:

Customer Services

Tel: +44 845 086 9001

Email (orders): orders@bsigroup.com

Email (enquiries): cservices@bsigroup.com

Subscriptions

Tel: +44 845 086 9001

Email: subscriptions@bsigroup.com

Knowledge Centre

Tel: +44 20 8996 7004

Email: knowledgecentre@bsigroup.com

Copyright & Licensing

Tel: +44 20 8996 7070

Email: copyright@bsigroup.com



...making excellence a habit.™