

BS ISO 23551-9:2015



BSI Standards Publication

Safety and control devices for gas burners and gas-burning appliances— Particular requirements

Part 9: Mechanical gas thermostats

bsi.

...making excellence a habit.™

National foreword

This British Standard is the UK implementation of ISO 23551-9:2015.

The UK participation in its preparation was entrusted to Technical Committee GSE/22, Safety and control devices for gas and oil burners appliances.

A list of organizations represented on this committee can be obtained on request to its secretary.

This publication does not purport to include all the necessary provisions of a contract. Users are responsible for its correct application.

© The British Standards Institution 2015.

Published by BSI Standards Limited 2015

ISBN 978 0 580 87102 3

ICS 27.060.20

Compliance with a British Standard cannot confer immunity from legal obligations.

This British Standard was published under the authority of the Standards Policy and Strategy Committee on 31 August 2015.

Amendments issued since publication

Date	Text affected
------	---------------

INTERNATIONAL
STANDARD

ISO
23551-9

First edition
2015-08-15

**Safety and control devices for gas
burners and gas-burning appliances —
Particular requirements —**

Part 9:
Mechanical gas thermostats

*Dispositifs de commande et de sécurité pour brûleurs à fioul et pour
appareils à fioul - Exigences particulières —*

Partie 9: Thermostats mécaniques



Reference number
ISO 23551-9:2015(E)

© ISO 2015



COPYRIGHT PROTECTED DOCUMENT

© ISO 2015, Published in Switzerland

All rights reserved. Unless otherwise specified, no part of this publication may be reproduced or utilized otherwise in any form or by any means, electronic or mechanical, including photocopying, or posting on the internet or an intranet, without prior written permission. Permission can be requested from either ISO at the address below or ISO's member body in the country of the requester.

ISO copyright office
Ch. de Blandonnet 8 • CP 401
CH-1214 Vernier, Geneva, Switzerland
Tel. +41 22 749 01 11
Fax +41 22 749 09 47
copyright@iso.org
www.iso.org

Contents

Page

Foreword	v
Introduction	vi
1 Scope	1
2 Normative references	1
3 Terms and definitions	1
4 Classification	3
4.1 Classes of controls.....	3
4.2 Groups of controls.....	3
5 Test conditions	3
6 Construction	4
6.1 General.....	4
6.2 Construction requirements.....	4
6.2.1 Appearance.....	4
6.2.2 Holes.....	4
6.2.3 Breather holes.....	4
6.2.4 Screwed fastenings.....	4
6.2.5 Jointing.....	4
6.2.6 Moving parts.....	4
6.2.7 Sealing caps.....	4
6.2.8 Dismantling and reassembling for servicing and/or adjustment.....	4
6.2.9 Auxiliary channels.....	4
6.3 Materials.....	5
6.3.1 General material requirements.....	5
6.3.2 Housing.....	5
6.3.3 Springs.....	5
6.3.4 Resistance to corrosion and surface protection.....	5
6.3.5 Impregnation.....	5
6.3.6 Seals for glands for moving parts.....	5
6.4 Gas connections.....	5
6.4.1 Making connections.....	5
6.4.2 Connection sizes.....	5
6.4.3 Threads.....	6
6.4.4 Union joints.....	6
6.4.5 Flanges.....	6
6.4.6 Compression fittings.....	6
6.4.7 Nipples for pressure tests.....	6
6.4.8 Strainers.....	6
7 Performance	7
7.1 General.....	7
7.2 Leak-tightness.....	7
7.2.1 Criteria.....	7
7.2.2 Test for leak-tightness.....	7
7.3 Torsion and bending.....	7
7.4 Rated flow rate.....	7
7.4.1 Criterion.....	7
7.4.2 Test for rated flow rate.....	8
7.5 Durability.....	8
7.6 Functional requirements.....	8
7.7 Endurance.....	14
7.7.1 Mechanical cycling.....	14
7.7.2 Thermal cycling.....	15

8	EMC/electrical requirements	16
9	Marking, installation, and operating instructions	16
9.1	Marking.....	16
9.2	Installation and operating instructions.....	17
9.3	Warning notice.....	17
Annex A	(informative) Leak-tightness test — Volumetric method	18
Annex B	(informative) Leak-tightness test — Pressure-loss method	19
Annex C	(normative) Conversion of pressure loss into leakage rate	20
Annex D	(normative) Test for immunity to power-frequency magnetic fields	21
Annex E	(normative) Specific regional requirements in European countries	22
Annex F	(normative) Specific regional requirements in Canada and USA	23
Annex G	(normative) Specific regional requirements in Japan	25
Bibliography	26

Foreword

ISO (the International Organization for Standardization) is a worldwide federation of national standards bodies (ISO member bodies). The work of preparing International Standards is normally carried out through ISO technical committees. Each member body interested in a subject for which a technical committee has been established has the right to be represented on that committee. International organizations, governmental and non-governmental, in liaison with ISO, also take part in the work. ISO collaborates closely with the International Electrotechnical Commission (IEC) on all matters of electrotechnical standardization.

The procedures used to develop this document and those intended for its further maintenance are described in the ISO/IEC Directives, Part 1. In particular the different approval criteria needed for the different types of ISO documents should be noted. This document was drafted in accordance with the editorial rules of the ISO/IEC Directives, Part 2 (see www.iso.org/directives).

Attention is drawn to the possibility that some of the elements of this document may be the subject of patent rights. ISO shall not be held responsible for identifying any or all such patent rights. Details of any patent rights identified during the development of the document will be in the Introduction and/or on the ISO list of patent declarations received (see www.iso.org/patents).

Any trade name used in this document is information given for the convenience of users and does not constitute an endorsement.

For an explanation on the meaning of ISO specific terms and expressions related to conformity assessment, as well as information about ISO's adherence to the WTO principles in the Technical Barriers to Trade (TBT) see the following URL: [Foreword - Supplementary information](#)

The committee responsible for this document is ISO/TC 161, *Control and protective devices for gas and/or oil burners and appliances*.

ISO 23551 consists of the following parts, under the general title *Safety and control devices for gas burners and gas-burning appliances — Particular requirements*:

- *Part 1: Automatic and semi-automatic valves*
- *Part 2: Pressure regulators*
- *Part 3: Gas/air ratio controls, pneumatic type*
- *Part 4: Valve-proving systems for automatic shut-off valves*
- *Part 5: Manual gas valves*
- *Part 6: Thermoelectric flame supervision controls*
- *Part 8: Multifunctional controls*
- *Part 9: Mechanical gas thermostats*

An additional part dealing with vent valves is planned.

Introduction

This part of ISO 23551 is designed to be used in combination with ISO 23550. This part of ISO 23551, together with ISO 23550, establishes the full requirements as they apply to the product covered by this International Standard. This part of ISO 23551 adapts ISO 23550, where needed, by stating “with the following modification”, “with the following addition”, “is replaced by the following”, or “is not applicable” in the corresponding clause. In order to identify specific requirements that are particular to this part of ISO 23551 that are not already covered by ISO 23550, this part of ISO 23551 may contain clauses or subclauses that are additional to the structure of ISO 23550. These clauses are numbered starting from 101 or, in the case of an Annex, are designated AA, BB, CC, etc.

In an attempt to develop an International Standard, it has been necessary to take into consideration the differing requirements resulting from practical experience and installation practices in various regions of the world and to recognize the variation in basic infrastructure associated with gas and/or oil controls and appliances, some of which are addressed in [Annex E](#) to [Annex G](#). This part of ISO 23551 intends to provide a basic framework of requirements that recognize these differences.

Safety and control devices for gas burners and gas-burning appliances — Particular requirements —

Part 9: Mechanical gas thermostats

1 Scope

This part of ISO 23551 specifies safety, constructional, and performance requirements and testing of mechanical gas thermostat for gas burners, gas appliances, and similar use hereafter referred to as “thermostats”.

This part of ISO 23551 covers type testing only.

This part of ISO 23551 applies to mechanical gas thermostats of nominal connection sizes up to and including DN 50 with declared maximum inlet pressures up to and including 50 kPa for burners and gas-burning appliances using fuel gases as natural gas, manufactured gas, and liquefied petroleum gas (LPG).

This part of ISO 23551 applies to mechanical thermostats controlling the gas flow directly or indirectly through an integral gas valve and which do not require external electrical energy for their operation.

This part of ISO 23551 only applies to mechanical thermostats used on gas appliances where the thermostat is not directly exposed to the outdoor environment.

This part of ISO 23551 only applies to mechanical thermostats which are intended for operating control functions.

2 Normative references

The following documents, in whole or in part, are normatively referenced in this document and are indispensable for its application. For dated references, only the edition cited applies. For undated references, the latest edition of the referenced document (including any amendments) applies.

ISO 23550:2011, *Safety and control devices for gas burners and gas-burning appliances — General requirements*

3 Terms and definitions

For the purposes of this document, the terms and definitions given in ISO 23550:2011 and the following apply.

3.101

mechanical thermostat

thermostat which controls the temperature by adjusting the flow rate accordingly to the temperature of the *thermal sensing element* (3.111) without any external energy such that the temperature remains within defined limits

3.102

adjustable thermostat

mechanical thermostat (3.101) in which the *temperature set-point* (3.115) can be adjusted by the user to anywhere between minimum and maximum values

3.103

fixed setting thermostat

mechanical thermostat (3.101) that has a preset fixed operating temperature which cannot be adjusted by the user

3.104

snap-acting thermostat

mechanical thermostat (3.101) with only two positions for the flow rate, i.e. “full on-off”, “full on-reduced rate”, or “reduced rate-off”

3.105

modulating thermostat

mechanical thermostat (3.101) which controls the flow rate in accordance with a predetermined and continuous function of the temperature of the *thermal sensing element* (3.111)

3.106

modulating thermostat with additional on-off action

mechanical thermostat (3.101) which acts as a *snap-acting thermostat* (3.104) between the closed and reduced positions and as a *modulating thermostat* (3.105) between the reduced and full-on positions

3.107

thermostat closure member

movable part of the thermostat which opens and closes the gas way and/or varies the flow rate

3.108

presetting device

device for adjusting an operating condition only by an authorized person

Note 1 to entry: It can be fixed or variable (e.g. when it is the gas flow that is adjustable, either an orifice or an adjusting screw can be used).

3.109

fixed bypass

non-adjustable presetting device for fixing the minimum gas flow through a thermostat

3.110

bypass adjusting device

screw adjustment or an exchangeable orifice that fixes the minimum gas flow rate through the thermostat and which is accessible only by the use of tools

3.111

thermal sensing element

part of a thermostat which is directly acted upon by temperature changes of the medium to be controlled or to be supervised and which through physical change, thus produced, originates the motion directly or indirectly controlling the action of the closure member

3.112

operating curve

graphical representation of the flow rate as a function of the thermal sensing element temperature at a given *temperature set-point* (3.115) and at a constant inlet pressure

3.113

backlash

difference of position of the *adjusting knob* (3.114) when it is moved in both directions to obtain the same flow rate at a constant thermal sensing element temperature

3.114

adjusting knob

spindle

dial

part of the thermostat which is used to select the *temperature set-point* (3.115)

3.115

temperature set-point

any value selected within the temperature range at which the controlled temperature should be maintained

3.116

temperature set-point range

range between the minimum and maximum adjustable *temperature set-points* (3.115) (by means of the *adjusting knob* (3.114))

3.117

calibration flow rate

flow rate declared by the manufacturer for calibration

3.118

calibration temperature set-point

temperature at which the *calibration flow rate* (3.117) should be obtained with the adjustment set to the position and in the direction declared by the manufacturer

3.119

temperature differential for snap-acting thermostats

difference in temperature necessary to obtain a change in the flow rate at a given set-point

3.120

deviation

maximum deviation from the *temperature set-point* (3.115) which is declared by the manufacturer

3.121

drift

permanent change in the *operating curve* (3.112) of the thermostat

3.122

bypass

passage provided in which permits a flow of gas to the main burner(s) independently of the action of the thermostatic valve

3.123

calibration reference point

dial setting at which a control is calibrated for agreement between dial indication and sensing element temperature

4 Classification

4.1 Classes of controls

ISO 23550:2011, 4.1 is not applicable.

4.2 Groups of controls

Shall be according to ISO 23550:2011, 4.2.

5 Test conditions

Shall be according to ISO 23550:2011, Clause 5 with the following addition:

Where applicable, the thermostat shall be mounted in an appropriate test fixture and the tests conducted with the thermal sensing element immersed in the intended medium (e.g. water, oil, or air) for the application as specified in the operation and installation instructions.

6 Construction

NOTE Regional specific requirements are given in [Annex F](#).

6.1 General

Shall be according to ISO 23550:2011, 6.1.

6.2 Construction requirements

6.2.1 Appearance

Shall be according to ISO 23550:2011, 6.2.1.

6.2.2 Holes

Shall be according to ISO 23550:2011, 6.2.2.

6.2.3 Breather holes

Shall be according to ISO 23550:2011, 6.2.3.

6.2.4 Screwed fastenings

Shall be according to ISO 23550:2011, 6.2.4.

6.2.5 Jointing

Shall be according to ISO 23550:2011, 6.2.5.

6.2.6 Moving parts

Shall be according to ISO 23550:2011, 6.2.6.

6.2.7 Sealing caps

Shall be according to ISO 23550:2011, 6.2.7.

6.2.8 Dismantling and reassembling for servicing and/or adjustment

Shall be according to ISO 23550:2011, 6.2.8 with the following addition:

If, in accordance with the manufacturer's instructions, the thermostat can be dismantled for servicing. Such action shall not result in a change in temperature calibration exceeding the declared maximum set point deviation ([7.6.101.1](#)).

Suitable means for maintaining all adjustments shall be provided. Lock nuts or adjusting nuts held by springs or compression will be considered satisfactory except where their adjustment can be accidentally disturbed.

6.2.9 Auxiliary channels

Shall be according to ISO 23550:2011, 6.2.9.

6.2.101 Presetting devices

A presetting device shall only be adjustable by use of a tool. The means of adjustment shall be easily accessible and shall not change of its own accord, but shall be protected against unauthorized interference, e.g. use of a sealing (lacquer).

A presetting device which connects a gas-carrying part to atmosphere shall provide leak tightness by means which shall not seal on the thread, e.g. use of an O-ring seal.

The presetting device shall not be able to fall into the gas ways of the thermostat. If an O-ring or equivalent gasket provides a seal against the atmosphere, then when the presetting device is completely unscrewed, it shall not be able to be pushed out by gas pressure and shall remain tight at the maximum pressure specified in [7.2.2](#).

If a presetting device is used for different gas families, it shall have a fixed minimum orifice.

A cover of any presetting device shall require a tool for removal and replacement and it shall not interfere with the adjustment of the temperature range.

6.3 Materials

Shall be according to ISO 23550:2011, 6.3.

6.3.1 General material requirements

Shall be according to ISO 23550:2011, 6.3.1.

NOTE Regional specific requirements are given in [Annex F](#).

6.3.2 Housing

Shall be according to ISO 23550:2011, 6.3.2.

6.3.3 Springs

Shall be according to ISO 23550:2011, 6.3.3.

6.3.4 Resistance to corrosion and surface protection

Shall be according to ISO 23550:2011, 6.3.4.

6.3.5 Impregnation

Shall be according to ISO 23550:2011, 6.3.5.

6.3.6 Seals for glands for moving parts

Shall be according to ISO 23550:2011, 6.3.6.

6.4 Gas connections

6.4.1 Making connections

Shall be according to ISO 23550:2011, 6.4.1.

6.4.2 Connection sizes

Shall be according to ISO 23550:2011, 6.4.2.

6.4.3 Threads

Shall be according to ISO 23550:2011, 6.4.3.

6.4.4 Union joints

Shall be according to ISO 23550:2011, 6.4.4.

6.4.5 Flanges

Shall be according to ISO 23550:2011, 6.4.5.

6.4.6 Compression fittings

Shall be according to ISO 23550:2011, 6.4.6.

6.4.7 Nipples for pressure tests

Shall be according to ISO 23550:2011, 6.4.7.

6.4.8 Strainers

Shall be according to ISO 23550:2011, 6.4.8.

6.101 Flow characteristics

An adjustable bypass shall be set by means of a variable presetting device or shall be adjusted by means of a fixed presetting device. Bypass rate adjustments shall be independent of pilot rate adjustments.

When specified by the manufacturer, it shall be possible to gain access to any fixed bypass or bypass adjusting device for cleaning without changing the calibration temperature set-point.

The opening and closing of the thermostat closure member with a total shut-off function shall happen by snap-action between the off position and the reduced flow position.

[Figure 2](#) shows typical operating curves of a modulating, snap-acting, and modulating on-off thermostat.

The flow rate at the moment of snap-action shall not be less than the value as specified in the operation and installation instructions.

6.102 Temperature adjustment

6.102.1 Range adjustment

The allowed temperature setting range shall be limited by stops. Where applicable, the operating instructions shall state the limits in which the temperature setting range can be adjusted using appropriate tools. The temperature setting range stops shall not change on their own accord.

6.102.2 Set point adjustment

If the adjusting knob is supplied as part of the thermostat, the marking of its positions shall be easily recognizable. It shall indicate the direction in which the temperature is raised or lowered. If numbers are used, higher numbers shall indicate higher temperatures, except for thermostats for refrigerators where higher numbers shall indicate lower temperatures.

It shall be possible to select any temperature set-point over the whole temperature range by setting the adjusting knob or spindle between the stops within the maximum and minimum ambient temperatures as stated in the operating instructions.

The temperature set-point adjustment means shall not change on its own accord.

6.102.3 Fixed setting thermostat

If provided, the adjustment means of a fixed setting thermostat shall be sealed (e.g. lacquer).

7 Performance

7.1 General

Shall be according to ISO 23550:2011, 7.1.

7.2 Leak-tightness

7.2.1 Criteria

Shall be according to ISO 23550:2011, 7.2.1.

NOTE Regional specific requirements are given in [Annex E](#).

7.2.2 Test for leak-tightness

7.2.2.1 General

Shall be according to ISO 23550:2011, 7.2.2.1.

7.2.2.2 External leak-tightness

Shall be according to ISO 23550:2011, 7.2.2.2.

7.2.2.3 Internal leak-tightness

Shall be according to ISO 23550:2011, 7.2.2.3 with the following addition:

This test applies only to thermostats with complete shut-off. The knob is set at the middle of its temperature setting range and the thermal sensing element is slowly heated (or cooled for controls for refrigerators) until the valve is closed. The temperature of the thermal sensing element is then increased (or decreased for refrigerators) by a value equal to 10 % of the temperature range of the thermostat. The thermostat is then checked for internal leak-tightness.

The test is carried out in the direction of gas flow.

7.3 Torsion and bending

Shall be according to ISO 23550:2011, 7.3.

7.4 Rated flow rate

7.4.1 Criterion

ISO 23550:2011, 7.4.1 is replaced by the following:

The rated flow rate and bypass flow rate shall be measured.

The measured flow rate shall be at least 0,9 times the rated flow rate.

For thermostats with a variable preset bypass, the bypass flow rate shall be adjustable over the whole range. For thermostats with a fixed preset bypass, the bypass flow rate shall remain within the tolerance limits.

The rated flow rate and the bypass flow rates are stated in the operating instructions.

7.4.2 Test for rated flow rate

7.4.2.1 Apparatus

Shall be according to ISO 23550:2011, 7.4.2.1.

7.4.2.2 Test procedure

ISO 23550:2011, 7.4.2.2 is replaced by the following:

Rated flow rate and bypass flow rate are taken from the operating curves as indicated in [7.6.105](#). The corrected flow rate and the corrected rated bypass flow rate according to [7.4.2.3](#) shall comply with the requirements of [7.4.1](#).

7.4.2.3 Conversion of air flow rate

Shall be according to ISO 23550:2011, 7.4.2.3.

7.5 Durability

Shall be according to ISO 23550:2011, 7.5.

7.6 Functional requirements

ISO 23550:2011, 7.6 is replaced by the following.

7.6.101 Calibration temperature set-point

7.6.101.1 Requirement

The deviation of the calibration temperature set-point at constant ambient temperature shall not exceed the value as stated in the operating instructions.

7.6.101.2 Test for calibration temperature set-point

With the body at the temperature of 20 ± 2 °C, the adjusting knob is set to the position and in the direction indicated by the manufacturer for calibration. The operating characteristic of the thermostat is drawn according to [7.6.105.2](#).

7.6.102 Backlash

7.6.102.1 Requirement

For modulating thermostats, the backlash shall not exceed 5 % of the angular movement of the setting point adjustment range of the thermostat.

7.6.102.2 Test for backlash

The thermal sensing element is held at a constant temperature equal to the middle of the temperature range.

The thermostat is supplied with air at 2 kPa. The pressure difference with all the thermostat closure members in the fully open position is adjusted to 250 Pa.

During the test, the body of the thermostat is maintained at a constant ambient temperature within ± 1 °C.

Turn the range spindle from the minimum temperature set-point until the calibration flow rate is obtained and record this position. Continue to turn the range spindle to the maximum temperature set-point and then turn the spindle back again to the position at which the calibration flow rate is obtained. Record this position. Measure the backlash which is the angular difference between these two positions.

7.6.103 Opening of a snap-acting thermostat with a closed position

7.6.103.1 Requirement

The total leakage of a snap-acting thermostat or of a modulating on-off thermostat during the opening procedure up to the point of snap-action shall not exceed 1 dm³ of air.

7.6.103.2 Test for opening of a snap-acting thermostat with a closed position

The thermostat is supplied with air at 2 kPa. The pressure difference with all the valves in the fully-open position is adjusted to 250 Pa.

During the test, the body of the thermostat is held at a constant ambient temperature within ± 1 °C.

The thermostat is set at the calibration temperature set-point as stated in the operating instructions. The thermal sensing element is immersed in a bath, the temperature of which is increased at a rate of 0,5 °C/min until the closure member is closed. The temperature is then lowered at the rate of 0,5 °C/min until the thermostat snaps open. During the lowering of the temperature, the total flow is measured from the temperature at which closure occurred up to the moment of snap-action.

For a refrigeration thermostat, the above temperature changes are reversed.

7.6.104 Opening pressure and closing pressure for thermostats with a closed position

7.6.104.1 Requirement

The thermostat shall be capable of opening and closing between the minimum and 1,2 times the maximum inlet pressure as specified in [9.1](#), but at least against a maximum pressure of 5 kPa.

7.6.104.2 Test for opening pressure and closing pressure for thermostats with a closed position

Using the equipment as shown in [Figure 1](#), a pressure equal to 1,2 times the maximum inlet pressure, but at least 5 kPa is supplied to the inlet of the thermostat. The pressure drop with the valve in the fully open position is adjusted to 250 Pa. Check that the valve opens and closes at a temperature change of the thermal sensing element.

7.6.105 Operating characteristic of the thermostat

7.6.105.1 Requirement

A thermostat shall maintain the temperature range and tolerances, temperature differential, and/or the modulation band as specified in the operation and installation instructions.

7.6.105.2 Test for operating characteristic of the thermostat

The test shall be carried out using air at an inlet pressure of 2 kPa. The thermostat shall be connected in the test equipment as indicated in [Figure 1](#).

With the closure member(s) in the open position, the pressure difference is adjusted to 250 Pa by actuating valve no. 8 flow rate control. There shall be no further modification to this adjustment during the tests described in this clause. The flow rate is then compared to the rated flow rate.

With the thermostat closure member of the modulating thermostat closed, the bypass, if provided, is adjusted to 20 % of the maximum flow rate or to a different value if declared by the manufacturer and it shall not be readjusted during the test.

As shown in [Figure 2](#), curves of thermostat flow rate versus temperature are plotted at both the minimum and maximum temperature set-points, first with falling temperature, and then with rising temperature. The curve will also be plotted for the calibration temperature set-point if it is different from the minimum or maximum. In this case, the setting is obtained by turning as indicated in [7.6.101.2](#).

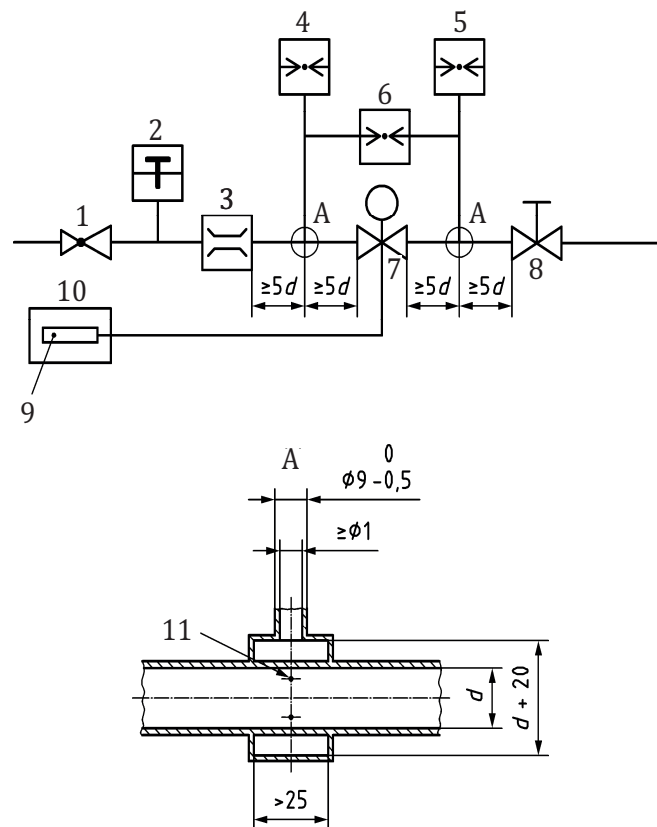

Nominal size (DN)	Internal diameter (mm)
6	6
8	9
10	13
15	16
20	22
25	28
32	35
40	41
50	52

Key

- | | | | |
|---|---|----|--------------------------------|
| 1 | adjustable regulator for inlet pressure | 7 | control under test |
| 2 | thermometer | 8 | manual control tap |
| 3 | flow meter | 9 | thermal sensing element |
| 4 | inlet pressure gauge | 10 | temperature controlled chamber |
| 5 | outlet pressure gauge | 11 | 4 holes \varnothing 1,5 mm |
| 6 | differential pressure gauge | | |

Figure 1 — Thermostat test apparatus

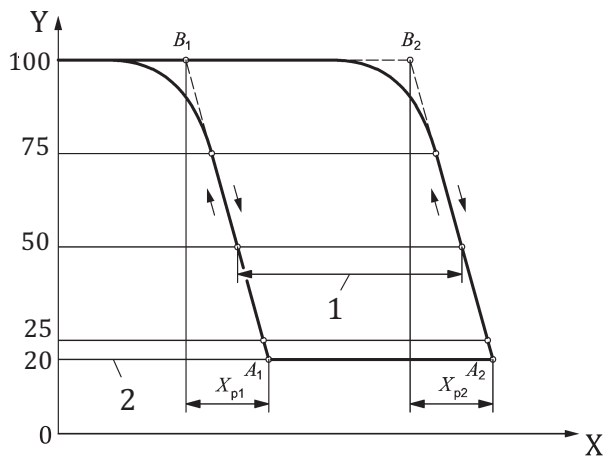

a) Modulating thermostat

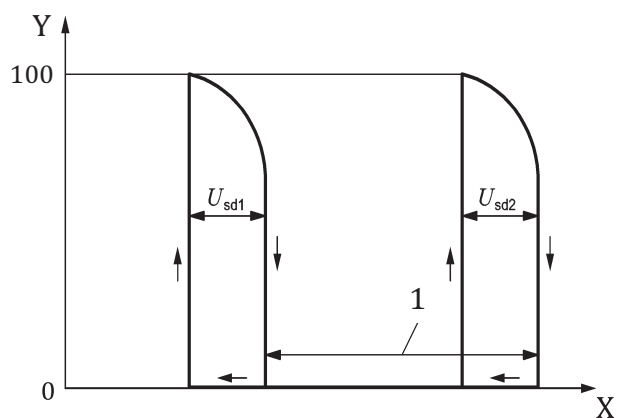

b) Snap-acting thermostat

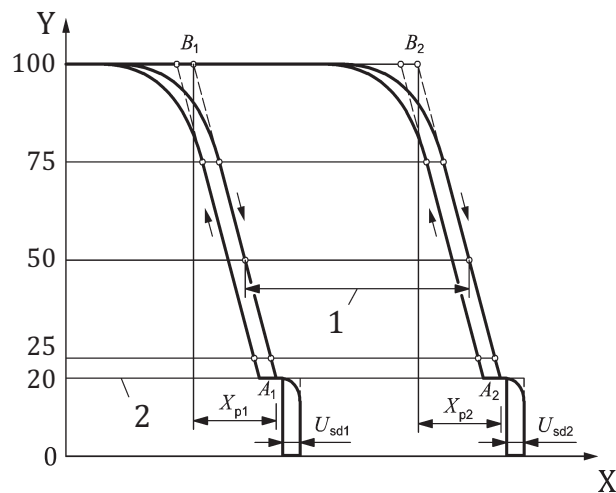

c) Modulating on-off thermostat

Key

- X thermal sensing element temperature in °C
- Y rated flow rate in %
- 1 temperature range in °C
- 2 by-pass flow rate in %
- X_{p1}, X_{p2} modulating band in °C
- U_{sd1}, U_{sd2} temperature differential in °C

Figure 2 — Typical operating characteristics of a thermostat over a range of temperature set-point adjustments

For each temperature set-point, the flow rate is given as a percentage of the maximum flow rate measured at that set-point (i.e. the maximum flow rate may be higher at higher temperature set-points).

In the modulating band or temperature differential, the thermal sensing element temperature is changed at a maximum rate of 1 °C/min.

To determine the modulating band, a straight line is drawn through the two points on the curve corresponding to the 75 % and 25 % of the rated flow rate and shall extend from the bypass flow rate A up to the rated flow rate B [see [Figure 2a](#)) and [Figure 2c](#)].

The modulating band, X_p , is the temperature difference between A and B [see [Figure 2a](#)) and [Figure 2c](#)].

The temperature differential, U_{sd} , for a snap-acting thermostat is shown in [Figure 2b](#)).

7.6.106 Ambient temperature range of the body

7.6.106.1 Requirement

The variation of the calibration temperature set-point due to temperature variation at the body of the thermostat shall not exceed the maximum value as declared by the manufacturer.

7.6.102.2 Test for ambient temperature range of the body

After the test in [7.6.101.2](#), the body of the thermostat is placed in a thermostatically controlled oven at $(60 \pm 2) ^\circ\text{C}$ or at the maximum temperature as stated in the operating instructions, whichever is higher.

Any change of calibration is measured in accordance with [7.6.101.2](#), when thermal equilibrium has been reached.

7.6.107 Effect of storage and transport temperatures

7.6.107.1 Requirement

The thermostat shall withstand an ambient temperature range of $-15 ^\circ\text{C}$ to $+60 ^\circ\text{C}$ or wider limits if declared by the manufacturer and stay within drift tolerances as stated in the operating instructions. The ambient temperature range for space heating and refrigeration thermostats shall be $-15 ^\circ\text{C}$ to $+50 ^\circ\text{C}$ or wider limits if declared by the manufacturer.

7.6.107.2 Test for effect of storage and transport temperatures

The thermostat, including capillary and thermal sensing element, is maintained at the minimum and then maximum temperature as specified in [7.6.107](#) for 2 h.

After returning to ambient temperature, any change of calibration is measured according to [7.6.101.2](#).

7.6.108 Thermal overload of the thermal sensing element

7.6.108.1 Requirement

The thermal sensing element shall withstand an overload temperature equal to its maximum operating temperature plus 15 % of the temperature range or $25 ^\circ\text{C}$, whichever is greater, and the thermostat shall stay within the drift tolerances as stated in the installation and operating instructions.

The exceptions are as given in [Table 1](#), [7.1](#).

7.6.108.2 Test for thermal overload of the thermal sensing element

During the test, the thermostat is adjusted to the maximum temperature set-point. The thermal sensing element is placed for 1 h at the maximum overload temperature given in [7.6.108.1](#), with the body of the thermostat at room temperature.

Any change of calibration is measured according to [7.6.101.2](#).

Table 1 — Exceptions for thermal overload

Application	Thermal sensing element overload temperature	
Water heating	110 °C	or greater if stated in the installation and operating instructions
Independent space heating and refrigerators	50 °C	

7.6.109 Operating torque of the thermostat set-point adjuster

7.6.109.1 Requirement

The torque required to turn the adjusting knob (or spindle) from and to the closed position shall not be greater than 0,5 Nm.

7.6.109.2 Test for operating torque of the thermostat set-point adjuster

The operating torque is measured with an appropriate torque meter having an accuracy of $\pm 10\%$ and at an operating speed of 1,5 rad/s.

The operating torque is measured at a thermal sensing element temperature which allows opening and closing of the closure member(s). Each test consists of five measurements of torque. The maximum recorded torque value is used.

7.6.110 Effect of high ambient temperature on performance of thermostats for top burners and griddles

7.6.110.1 Requirement

The variation of the calibration temperature set-point due to temperature variation at the body of the thermostat from 32 °C to 149 °C (90 °F to 300 °F) shall not exceed 8,5 °C (15 °F).

7.6.110.2 Test

The thermostat dial is set at 149 °C (300 °F). The body of the thermostat is placed in a thermostatically controlled chamber at 32 ± 2 °C (90 ± 3 °F), the calibration is measured in accordance with [7.6.101.2](#), when thermal equilibrium has been reached. The temperature of the chamber is then increased to 149 ± 2 °C (300 ± 3 °F). Any change of calibration is measured in accordance with [7.6.101.2](#), when thermal equilibrium has been reached.

7.7 Endurance

NOTE Regional specific requirements are given in [Annex F](#).

7.7.1 Mechanical cycling

7.7.1.1 Requirement

The thermostat shall comply with the following requirements before and after the endurance test of [7.7.1.2](#):

- [7.6.109](#);
- [7.6.102](#);
- [7.2](#);

— [7.6.101](#).

7.7.1.2 Test

Each mechanical cycle consists of a movement of the setting means over its complete travel and a return to its starting point. The rate of cycling is approximately 10 per min.

The testing apparatus shall allow the setting means to operate smoothly and without interfering with the normal operation of the thermostat and will apply a torque not greater than 0,5 Nm.

Throughout the cycle, the spindle is held in the unlatched position so that the latch-pin is not in contact with its guide.

The total number of cycles, N , is that given in [Table 2](#) according to the declared application or as stated in the operating instructions if greater than the value given in [Table 2](#).

The thermostat shall be first cycled with the body at the declared maximum temperature for $N/2$ cycles, then with the body at a temperature of $(20 \pm 5) ^\circ\text{C}$ for $N/2$ cycles.

Throughout the test, the thermal sensing element shall be held at a temperature approximately equal to two-thirds of the temperature range above the minimum setting.

No additional lubrication or adjustment is permitted during the test.

Table 2 — Number of mechanical cycles

Number of cycles		
N		
Type of thermostat	Thermostats for hotplates and instantaneous water heaters	All other thermostats
No tap fitted	5 000	1 000
Integral tap operated by set-point adjuster	30 000	5 000

7.7.2 Thermal cycling

7.7.2.1 Requirement

The thermostat shall comply with the following requirements before and after the endurance test of [7.7.2.2](#):

- [7.2](#);
- [7.6.101](#);
- [7.6.105](#).

7.7.2.2 Test

Each thermal cycle consists of changing the temperature of the thermal sensing element to either side of T_s and returning to its starting temperature.

The adjusting knob is set to the temperature corresponding to T_s where T_s is calculated as follows:

$$T_s = T_u + 2/3 (T_o - T_u) \quad (1)$$

where

T_o is the maximum temperature set-point;

T_u is the minimum temperature set-point.

The test is made with air flowing through the thermostat and at a pressure of 2 kPa.

The body shall be maintained at (60 ± 2) °C or at a higher temperature as stated in the operating instructions.

The temperature change and number of cycles shall be chosen in such a way that

- in the case of a modulating thermostat, the whole of the proportional band is used, 10 000 cycles;
- for snap-action thermostats, the differential is used, 100 000 cycles;
- for combined modulating/snap-action, the proportional band plus the differential band is used, 10 000 cycles.

8 EMC/electrical requirements

ISO 23550:2011, Clause 8 is not applicable.

9 Marking, installation, and operating instructions

9.1 Marking

ISO 23550:2011, 9.1 is replaced by the following:

The following information, at least, shall be durably marked on the thermostat in a clearly visible position:

- a) manufacturer and/or trade mark;
- b) type reference;
- c) maximum inlet pressure in Pa or kPa ([7.6.104](#));
- d) ambient temperature range;
- e) group 1 (if applicable);
- f) direction of gas flow (by a cast or embossed arrow);

NOTE 1 f) is not necessary if the thermostat is constructed and intended for only one type of gas appliance and if incorrect installation is impossible.

- g) date of manufacture (at least year) — may be in code;
- h) when means are provided for the user to vary the temperature setting, such means shall clearly indicate the direction of movement to increase or decrease the temperature and the minimum and maximum operating positions. One of the dial graduations shall be located at the calibration reference point.

NOTE 2 Regional specific requirements are given in [Annex F](#) and [Annex G](#).

9.2 Installation and operating instructions

Shall be according to ISO 23550:2011, 9.2 with the following addition:

Instructions shall include all relevant information on use, installation, operation, and servicing, in particular the following:

- a) type reference;
- b) number of mechanical cycles ([7.7.1.2](#));
- c) group 1 (if applicable);
- d) rated flow rate;
- e) ambient temperature range;
- f) mounting position(s);
- g) inlet pressure range in Pa or kPa;
- h) gas connection(s);
- i) gas families for which the thermostat is suitable;
- j) the thermal overload temperature and the related thermostat drift tolerance ([7.6.108](#));
- k) conversion to other gas families;
- l) the temperature range and its tolerances, the temperature differential, and the modulation band ([7.6.105](#));
- m) minimum flow ([6.101](#)), bypass flow rate, or bypass flow rate change ([7.4](#));
- n) the thermostat drift tolerance due to storage and transport temperature ([7.6.107](#));
- o) the calibration temperature set-point and effect of ambient temperature ([7.6.101](#), [7.6.106](#));
- p) notice for installer to consider, e.g. condition for up-stream pressure, dirt, corrosion products.

9.3 Warning notice

Shall be according to ISO 23550:2011, 9.3.

Annex A
(informative)

Leak-tightness test — Volumetric method

Shall be according to ISO 23550:2011, Annex A.

Annex B
(informative)

Leak-tightness test — Pressure-loss method

Shall be according to ISO 23550:2011, Annex B.

Annex C (normative)

Conversion of pressure loss into leakage rate

Shall be according to ISO 23550:2011, Annex C.

Annex D
(normative)

Test for immunity to power-frequency magnetic fields

ISO 23550:2011, Annex D is not applicable.

Annex E (normative)

Specific regional requirements in European countries

E.1 General

For the purposes of this part of ISO 23551, the specific regional requirements given in 0 modify this part of ISO 23551 as it applies in Europe. Only the affected subclauses are mentioned, hence the numbering is non-consecutive.

E.2 Additional requirements

E.7.2.1 Criteria

ISO 23550:2011, 7.2.1 is replaced by the following:

Thermostats shall be leak-tight in accordance with the leakage rates given in [Table E.1](#).

Table E.1 — Maximum leakage rates

Nominal size (inlet) DN	Maximum leakage rate cm ³ /h of air	
	Internal leak-tightness ^a	External leak-tightness
DN < 10	60	20
10 ≤ DN ≤ 15	60	40
15 < DN ≤ 25	80	40
25 < DN ≤ 50	120	60

^a This requirement applies only to thermostats with complete shut-off.

Annex F **(normative)**

Specific regional requirements in Canada and USA

Shall be according to ISO 23550:2011, Annex F with the following addition:

F.1 General

For the purposes of this part of ISO 23551, the specific regional requirements given in [F.2](#) modify this part of ISO 23551 as it applies in Canada and the USA. Only the affected subclauses are mentioned, hence the numbering is non-consecutive.

F.2 Additional requirements

F.2.1

graduating thermostat

thermostat in which the motion of the valve is approximately in direct proportion to the effective motion of the thermal element induced by temperature change

F.2.2

maximum operating position

highest dial marking temperature for heating thermostats or the lowest dial marking temperature for refrigeration thermostats

F.2.3

thermostatic valve mechanism linkage

part(s) of the thermostat which transmits motion originated by the thermal element or resulting from manual adjustment of the dial to the closure member

F.5 Construction

F.5.101 Parts in contact with potable water

For a control containing part(s) intended for contact with potable water, the manufacturer shall supply evidence satisfactory to the testing agency that material used as a protective coating for thermal sensing element tubes is suitable for the service, particularly with respect to toxicity, solubility, brittleness, and temperature limits. Evidence of current certification under ANSI/NSF 14 with appropriate end use shall be deemed acceptable.

F.8.1 Marking

F.8.1.101 Temperature markings

F.8.1.101.1

For thermostats provided with dials for use on ovens and broilers, the dials shall be marked with successively numbered temperatures not more than 28 °C (50 °F) apart. Above 93,5 °C (200 °F), graduations shall be provided at least every 14 °C (25 °F).

F.8.1.101.2

Thermostats for use on water heaters shall have a detent or legible marking consistent with a temperature of approximately 49 °C (120 °F).

Annex G (normative)

Specific regional requirements in Japan

Shall be according to ISO 23550:2011, Annex G with the following addition:

G.1 General

For the purposes of this part of ISO 23551, the specific regional requirements given in [G.2](#) modify this part of ISO 23551 as it applies in Japan. Only the affected subclauses are mentioned, hence the numbering is non-consecutive.

G.2 Additional requirements

G.9.1 Marking

G.9.1 b), c), d), e), and f) are not applicable.

Bibliography

- [1] NSF/ANSI 14, *Plastics piping system components and related materials*

British Standards Institution (BSI)

BSI is the national body responsible for preparing British Standards and other standards-related publications, information and services.

BSI is incorporated by Royal Charter. British Standards and other standardization products are published by BSI Standards Limited.

About us

We bring together business, industry, government, consumers, innovators and others to shape their combined experience and expertise into standards-based solutions.

The knowledge embodied in our standards has been carefully assembled in a dependable format and refined through our open consultation process. Organizations of all sizes and across all sectors choose standards to help them achieve their goals.

Information on standards

We can provide you with the knowledge that your organization needs to succeed. Find out more about British Standards by visiting our website at bsigroup.com/standards or contacting our Customer Services team or Knowledge Centre.

Buying standards

You can buy and download PDF versions of BSI publications, including British and adopted European and international standards, through our website at bsigroup.com/shop, where hard copies can also be purchased.

If you need international and foreign standards from other Standards Development Organizations, hard copies can be ordered from our Customer Services team.

Subscriptions

Our range of subscription services are designed to make using standards easier for you. For further information on our subscription products go to bsigroup.com/subscriptions.

With **British Standards Online (BSOL)** you'll have instant access to over 55,000 British and adopted European and international standards from your desktop. It's available 24/7 and is refreshed daily so you'll always be up to date.

You can keep in touch with standards developments and receive substantial discounts on the purchase price of standards, both in single copy and subscription format, by becoming a **BSI Subscribing Member**.

PLUS is an updating service exclusive to BSI Subscribing Members. You will automatically receive the latest hard copy of your standards when they're revised or replaced.

To find out more about becoming a BSI Subscribing Member and the benefits of membership, please visit bsigroup.com/shop.

With a **Multi-User Network Licence (MUNL)** you are able to host standards publications on your intranet. Licences can cover as few or as many users as you wish. With updates supplied as soon as they're available, you can be sure your documentation is current. For further information, email bsmusales@bsigroup.com.

BSI Group Headquarters

389 Chiswick High Road London W4 4AL UK

Revisions

Our British Standards and other publications are updated by amendment or revision.

We continually improve the quality of our products and services to benefit your business. If you find an inaccuracy or ambiguity within a British Standard or other BSI publication please inform the Knowledge Centre.

Copyright

All the data, software and documentation set out in all British Standards and other BSI publications are the property of and copyrighted by BSI, or some person or entity that owns copyright in the information used (such as the international standardization bodies) and has formally licensed such information to BSI for commercial publication and use. Except as permitted under the Copyright, Designs and Patents Act 1988 no extract may be reproduced, stored in a retrieval system or transmitted in any form or by any means – electronic, photocopying, recording or otherwise – without prior written permission from BSI. Details and advice can be obtained from the Copyright & Licensing Department.

Useful Contacts:

Customer Services

Tel: +44 845 086 9001

Email (orders): orders@bsigroup.com

Email (enquiries): cservices@bsigroup.com

Subscriptions

Tel: +44 845 086 9001

Email: subscriptions@bsigroup.com

Knowledge Centre

Tel: +44 20 8996 7004

Email: knowledgecentre@bsigroup.com

Copyright & Licensing

Tel: +44 20 8996 7070

Email: copyright@bsigroup.com



...making excellence a habit.™