

BS ISO 23509:2016



BSI Standards Publication

Bevel and hypoid gear geometry

National foreword

This British Standard is the UK implementation of ISO 23509:2016. It supersedes BS ISO 23509:2006 which is withdrawn.

The UK participation in its preparation was entrusted to Technical Committee MCE/5/-/13, Bevel gears.

A list of organizations represented on this committee can be obtained on request to its secretary.

This publication does not purport to include all the necessary provisions of a contract. Users are responsible for its correct application.

© The British Standards Institution 2016.
Published by BSI Standards Limited 2016

ISBN 978 0 580 86045 4

ICS 21.200

Compliance with a British Standard cannot confer immunity from legal obligations.

This British Standard was published under the authority of the Standards Policy and Strategy Committee on 30 November 2016.

Amendments/corrigenda issued since publication

Date	Text affected
------	---------------

INTERNATIONAL
STANDARD

BS ISO 23509:2016

ISO
23509

Second edition
2016-11-15

Bevel and hypoid gear geometry

Géométrie des engrenages coniques et hypoïdes



Reference number
ISO 23509:2016(E)

© ISO 2016



COPYRIGHT PROTECTED DOCUMENT

© ISO 2016, Published in Switzerland

All rights reserved. Unless otherwise specified, no part of this publication may be reproduced or utilized otherwise in any form or by any means, electronic or mechanical, including photocopying, or posting on the internet or an intranet, without prior written permission. Permission can be requested from either ISO at the address below or ISO's member body in the country of the requester.

ISO copyright office
Ch. de Blandonnet 8 • CP 401
CH-1214 Vernier, Geneva, Switzerland
Tel. +41 22 749 01 11
Fax +41 22 749 09 47
copyright@iso.org
www.iso.org

Contents

Page

Foreword	v
Introduction	vi
1 Scope	1
2 Normative references	1
3 Terms, definitions and symbols	1
3.1 Terms and definitions.....	5
3.2 Symbols.....	7
4 Design considerations	9
4.1 General.....	9
4.2 Types of bevel gears.....	10
4.2.1 General.....	10
4.2.2 Straight bevels.....	10
4.2.3 Spiral bevels.....	10
4.2.4 Zerol bevels.....	10
4.2.5 Hypoids.....	11
4.3 Ratios.....	11
4.4 Hand of spiral.....	11
4.5 Preliminary gear size.....	12
5 Tooth geometry and cutting considerations	12
5.1 Manufacturing considerations.....	12
5.2 Tooth taper.....	12
5.3 Tooth depth configurations.....	14
5.3.1 Taper depth.....	14
5.3.2 Uniform depth.....	15
5.4 Dedendum angle modifications.....	17
5.5 Cutter radius.....	17
5.6 Mean radius of curvature.....	17
5.7 Hypoid design.....	18
5.8 Most general type of gearing.....	18
5.9 Hypoid geometry.....	19
5.9.1 Basics.....	19
5.9.2 Crossing point.....	21
6 Pitch cone parameters	21
6.1 Initial data for pitch cone parameters.....	21
6.2 Determination of pitch cone parameters for bevel and hypoid gears.....	22
6.2.1 Method 0.....	22
6.2.2 Method 1.....	22
6.2.3 Method 2.....	26
6.2.4 Method 3.....	31
7 Gear dimensions	33
7.1 Initial data for tooth profile parameters.....	33
7.2 Determination of basic data.....	36
7.3 Determination of tooth depth at calculation point.....	38
7.4 Determination of root angles and face angles.....	38
7.5 Determination of pinion face width, b_1	40
7.6 Determination of inner and outer spiral angles.....	42
7.6.1 Pinion.....	42
7.6.2 Wheel.....	43
7.7 Determination of tooth depth.....	44
7.8 Determination of tooth thickness.....	44
7.9 Determination of remaining dimensions.....	46

8	Undercut check	47
8.1	Pinion	47
8.2	Wheel	49
Annex A	(informative) Structure of ISO formula set for calculation of geometry data of bevel and hypoid gears	51
Annex B	(informative) Pitch cone parameters	57
Annex C	(informative) Gear dimensions	68
Annex D	(informative) Analysis of forces	75
Annex E	(informative) Machine tool data	78
Annex F	(informative) Sample calculations	79
Bibliography	138

Foreword

ISO (the International Organization for Standardization) is a worldwide federation of national standards bodies (ISO member bodies). The work of preparing International Standards is normally carried out through ISO technical committees. Each member body interested in a subject for which a technical committee has been established has the right to be represented on that committee. International organizations, governmental and non-governmental, in liaison with ISO, also take part in the work. ISO collaborates closely with the International Electrotechnical Commission (IEC) on all matters of electrotechnical standardization.

The procedures used to develop this document and those intended for its further maintenance are described in the ISO/IEC Directives, Part 1. In particular the different approval criteria needed for the different types of ISO documents should be noted. This document was drafted in accordance with the editorial rules of the ISO/IEC Directives, Part 2 (see www.iso.org/directives).

Attention is drawn to the possibility that some of the elements of this document may be the subject of patent rights. ISO shall not be held responsible for identifying any or all such patent rights. Details of any patent rights identified during the development of the document will be in the Introduction and/or on the ISO list of patent declarations received (see www.iso.org/patents).

Any trade name used in this document is information given for the convenience of users and does not constitute an endorsement.

For an explanation on the meaning of ISO specific terms and expressions related to conformity assessment, as well as information about ISO's adherence to the World Trade Organization (WTO) principles in the Technical Barriers to Trade (TBT) see the following URL: www.iso.org/iso/foreword.html.

The committee responsible for this document is ISO/TC 60, *Gears*, Subcommittee SC 2, *Gear capacity calculation*.

This second edition cancels and replaces the first edition (ISO 23509:2006), which has been technically revised with the following changes:

- minor corrections of several formulae;
- the figures have been reworked;
- explanations have been added in [4.4](#);
- the structure of [Formula \(129\)](#) has been changed to cover the case $\zeta_m = 0^\circ$;
- a formula for the calculation of c_{be2} has been added as [Formula \(F.160\)](#);
- the values for α_{nC} and α_{nD} in [Formulae \(F.318\)](#) and [\(F.319\)](#) have been extended to three decimal digits to prevent rounding errors.

Introduction

For many decades, information on bevel, and especially hypoid, gear geometry has been developed and published by the gear machine manufacturers. It is clear that the specific formulae for their respective geometries were developed for the mechanical generation methods of their particular machines and tools. In many cases, these formulae could not be used in general for all bevel gear types. This situation changed with the introduction of universal, multi-axis, CNC-machines, which in principle are able to produce nearly all types of gearing. The manufacturers were, therefore, asked to provide CNC programs for the geometries of different bevel gear generation methods on their machines.

This document integrates straight bevel gears and the three major design generation methods for spiral bevel gears into one complete set of formulae. In only a few places do specific formulae for each method have to be applied. The structure of the formulae is such that they can be programmed directly, allowing the user to compare the different designs.

The formulae of the three methods are developed for the general case of hypoid gears and to calculate the specific case of spiral bevel gears by entering zero for the hypoid offset. Additionally, the geometries correspond such that each gear set consists of a generated or non-generated wheel without offset and a pinion which is generated and provided with the total hypoid offset.

An additional objective of this document is that, on the basis of the combined bevel gear geometries, an ISO hypoid gear rating system can be established in the future.

Bevel and hypoid gear geometry

1 Scope

This document specifies the geometry of bevel gears.

The term bevel gears is used to mean straight, spiral, zerol bevel and hypoid gear designs. If the text pertains to one or more, but not all, of these, the specific forms are identified.

The manufacturing process of forming the desired tooth form is not intended to imply any specific process, but rather to be general in nature and applicable to all methods of manufacture.

The geometry for the calculation of factors used in bevel gear rating, such as ISO 10300 (all parts), is also included.

This document is intended for use by an experienced gear designer capable of selecting reasonable values for the factors based on his/her knowledge and background. It is not intended for use by the engineering public at large.

[Annex A](#) provides a structure for the calculation of the methods provided in this document.

2 Normative references

There are no normative references in this document.

3 Terms, definitions and symbols

For the purposes of this document, the terms and definitions given in ISO 1122-1 and the following apply.

ISO and IEC maintain terminological databases for use in standardization at the following addresses:

- IEC Electropedia: available at <http://www.electropedia.org/>
- ISO Online browsing platform: available at <http://www.iso.org/obp>

NOTE 1 The symbols, terms and definitions used in this document are, wherever possible, consistent with other International Standards. It is known, because of certain limitations, that some symbols, their terms and definitions, as used in this document, are different from those used in similar literature pertaining to spur and helical gearing.

NOTE 2 Bevel gear nomenclature used throughout this document is illustrated in [Figure 1](#), the axial section of a bevel gear, and in [Figure 2](#), the mean transverse section. Hypoid nomenclature is illustrated in [Figure 3](#).

Subscript 1 refers to the pinion and subscript 2 to the wheel.

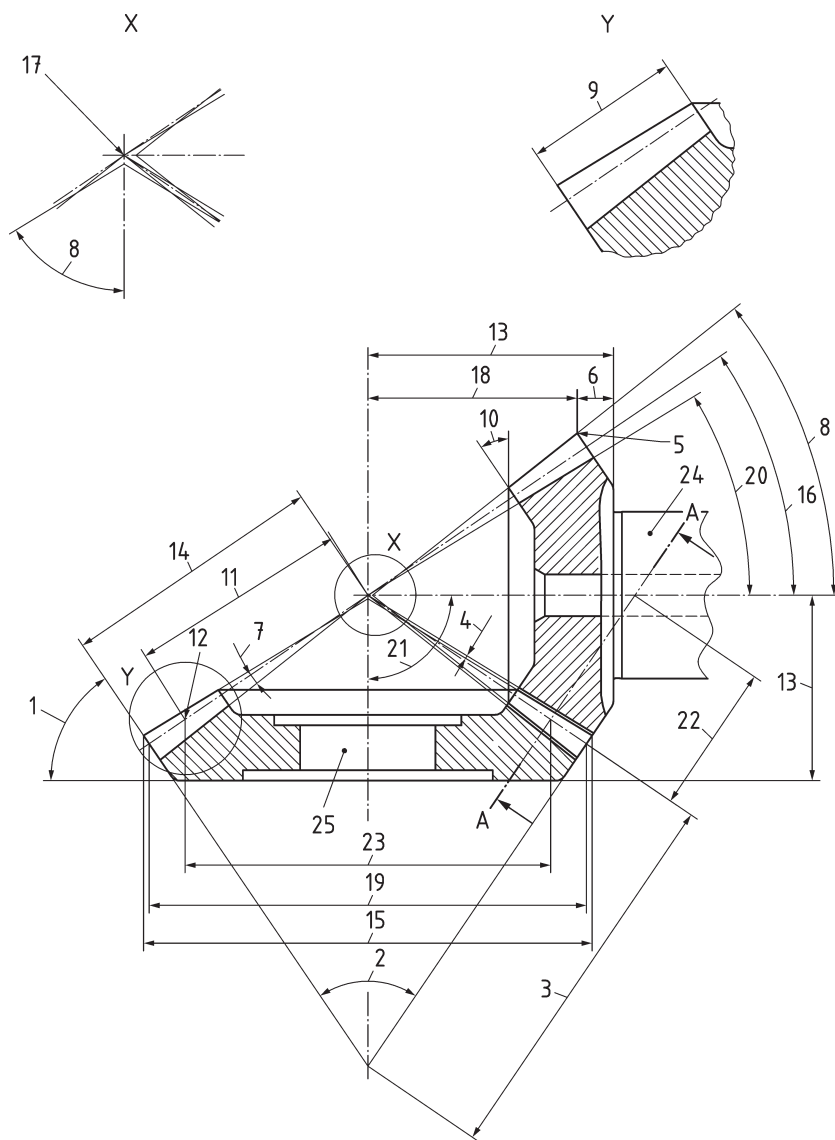

Key

1	back angle	10	front angle	19	outer pitch diameter, d_{e1}, d_{e2}
2	back cone angle	11	mean cone distance, R_m	20	root angle, δ_{f1}, δ_{f2}
3	back cone distance	12	mean point	21	shaft angle, Σ
4	clearance, c	13	mounting distance	22	equivalent pitch radius
5	crown point	14	outer cone distance, R_e	23	mean pitch diameter, d_{m1}, d_{m2}
6	crown to back	15	outside diameter, d_{ae1}, d_{ae2}	24	pinion
7	dedendum angle, θ_{f1}, θ_{f2}	16	pitch angle, δ_1, δ_2	25	wheel
8	face angle δ_{a1}, δ_{a2}	17	pitch cone apex		
9	face width, b	18	crown to crossing point, t_{x01}, t_{x02}		

NOTE See [Figure 2](#) for mean transverse section, A-A.

Figure 1 — Bevel gear nomenclature — Axial plane

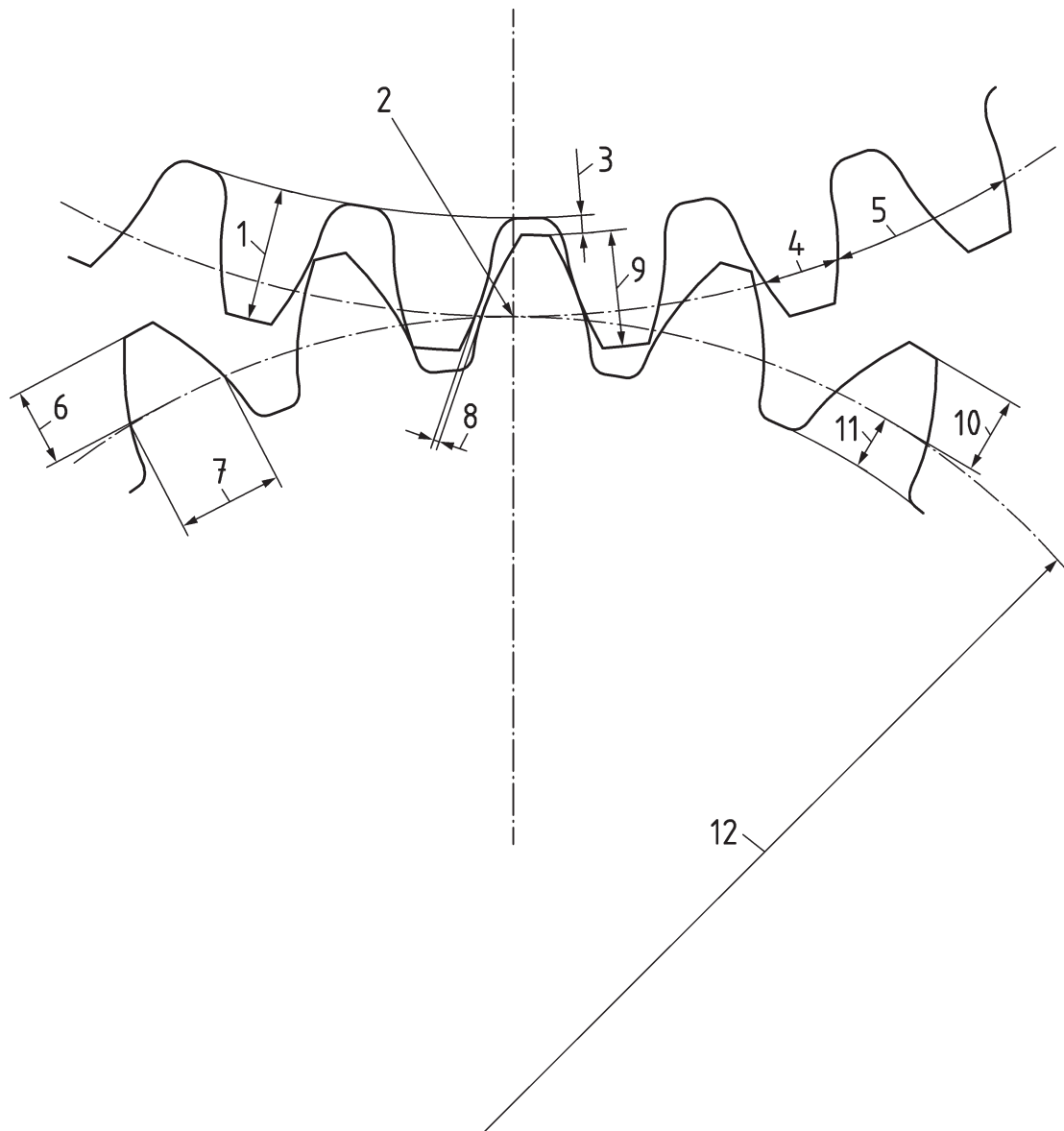

Key

1	whole depth, h_m	5	circular pitch	9	working depth, h_{mw}
2	pitch point	6	chordal addendum	10	addendum, h_{am}
3	clearance, c	7	chordal thickness	11	dedendum, h_{fm}
4	circular thickness	8	backlash	12	equivalent pitch radius

NOTE See A-A in [Figure 1](#).

Figure 2 — Bevel gear nomenclature — Mean transverse section

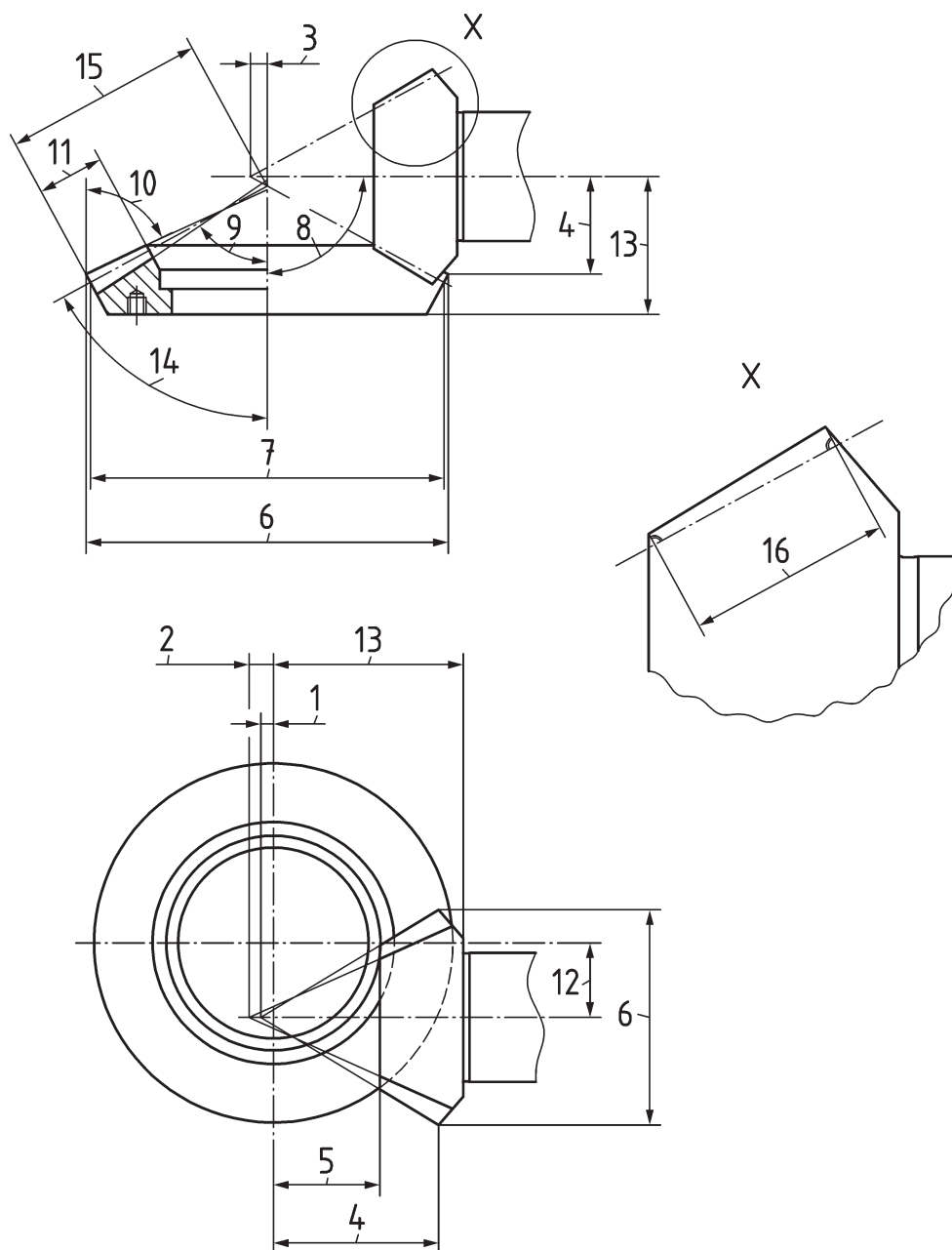

Key

1	face apex beyond crossing point, t_{zF1}	7	outer pitch diameter, d_{e1}, d_{e2}	13	mounting distance
2	root apex beyond crossing point, t_{zR1}	8	shaft angle, Σ	14	pitch angle, δ_2
3	pitch apex beyond crossing point, t_{z1}	9	root angle, δ_{f1}, δ_{f2}	15	outer cone distance, R_e
4	crown to crossing point, t_{x01}, t_{x02}	10	face angle of blank, δ_{a1}, δ_{a2}	16	pinion face width, b_1
5	front crown to crossing point, t_{xi1}	11	wheel face width, b_2		
6	outside diameter, d_{ae1}, d_{ae2}	12	hypoid offset, a		

NOTE Apex beyond crossing point values are positive when crossing point lies inside the respective cone.

Figure 3 — Hypoid nomenclature

3.1 Terms and definitions

3.1.1

mean chordal addendum

h_{amc1}, h_{amc2}

height from the top of the gear tooth to the chord subtending the circular thickness arc at the mean cone distance in a plane normal to the tooth face

3.1.2

mean addendum

h_{am1}, h_{am2}

height by which the gear tooth projects above the pitch cone at the mean cone distance

3.1.3

outer normal backlash allowance

j_{en}

amount by which the tooth thicknesses are reduced to provide the necessary backlash in assembly

Note 1 to entry: It is specified at the outer cone distance.

3.1.4

coast side

<by normal convention> convex pinion flank in mesh with the concave wheel flank

3.1.5

cutter radius

r_{c0}

nominal radius of the face type cutter or cup-shaped grinding wheel that is used to cut or grind the spiral bevel teeth

3.1.6

sum of dedendum angles

$\Sigma\theta_f$

sum of the pinion and wheel dedendum angles

3.1.7

sum of constant slot width dedendum angles

$\Sigma\theta_{fC}$

sum of dedendum angles for constant slot width

3.1.8

sum of modified slot width dedendum angles

$\Sigma\theta_{fM}$

sum of dedendum angles for modified slot width taper

3.1.9

sum of standard depth dedendum angles

$\Sigma\theta_{fS}$

sum of dedendum angles for standard depth taper

3.1.10

sum of uniform depth dedendum angles

$\Sigma\theta_{fU}$

sum of dedendum angles for uniform depth

3.1.11

mean dedendum

h_{fm1}, h_{fm2}

depth of the tooth space below the pitch cone at the mean cone distance

3.1.12
mean whole depth

h_m
tooth depth at mean cone distance

3.1.13
mean working depth

h_{mw}
depth of engagement of two gears at mean cone distance

3.1.14
direction of rotation

direction determined by an observer viewing the gear from the back looking towards the pitch apex

3.1.15
drive side

by normal convention, concave pinion flank in mesh with the convex wheel flank

3.1.16
face width

b
length of the teeth measured along a pitch cone element

3.1.17
mean addendum factor

c_{ham}
apportions the mean working depth between wheel and pinion mean addendums

Note 1 to entry: The gear mean addendum is equal to c_{ham} times the mean working depth.

3.1.18
mean radius of curvature

$\rho_{m\beta}$
radius of curvature of the tooth surface in the lengthwise direction at the mean cone distance

3.1.19
number of blade groups

Z_0
number of blade groups contained in the circumference of the cutting tool

3.1.20
number of teeth

Z_1, Z_2
number of teeth contained in the whole circumference of the pitch cone

3.1.21
number of crown gear teeth

Z_p
number of teeth in the whole circumference of the crown gear

Note 1 to entry: The number may not be an integer.

3.1.22
mean normal chordal tooth thickness

S_{mnc1}, S_{mnc2}
chordal thickness of the gear tooth at the mean cone distance in a plane normal to the tooth trace

3.1.23 mean normal circular tooth thickness

s_{mn1}, s_{mn2}

length of arc on the pitch cone between the two sides of the gear tooth at the mean cone distance in the plane normal to the tooth trace

3.1.24 tooth trace

curve of the tooth on the pitch surface

3.1.25 mean point

point where the calculation of basic geometry is executed

Note 1 to entry: Mean point does not necessarily coincide with middle point of face width.

Note 2 to entry: In all the methods listed in this document, the term “mean point” refers to “calculation point”. See [A.3](#) for calculation points.

3.2 Symbols

Table 1 — Symbols used in this document

Symbol	Description	Unit
a	hypoid offset	mm
b_1, b_2	face width	mm
b_{e1}, b_{e2}	face width from calculation point to outside	mm
b_{i1}, b_{i2}	face width from calculation point to inside	mm
c	clearance	mm
c_{be2}	face width factor	—
c_{ham}	mean addendum factor of wheel	—
d_{ae1}, d_{ae2}	outside diameter	mm
d_{e1}, d_{e2}	outer pitch diameter	mm
d_{m1}, d_{m2}	mean pitch diameter	mm
F_{ax}	axial force	N
F_{mt1}, F_{mt2}	tangential force at mean diameter	N
F_{rad}	radial force	N
$f_{\alpha lim}$	influence factor of limit pressure angle	—
h_{ae1}, h_{ae2}	outer addendum	mm
h_{am1}, h_{am2}	mean addendum	mm
h_{amc1}, h_{amc2}	mean chordal addendum	mm
h_{e1}, h_{e2}	outer whole depth	mm
h_{fe1}, h_{fe2}	outer dedendum	mm
h_{fi1}, h_{fi2}	inner dedendum	mm
h_{fm1}, h_{fm2}	mean dedendum	mm
h_m	mean whole depth	mm
h_{mw}	mean working depth	mm
h_{t1}	pinion whole depth	mm
j_{en}	outer normal backlash	mm
j_{et}	outer transverse backlash	mm
j_{mn}	mean normal backlash	mm

Table 1 (continued)

Symbol	Description	Unit
j_{mt}	mean transverse backlash	mm
k_c	clearance factor	—
k_d	depth factor	—
k_{hap}	basic crown gear addendum factor (related to m_{mn})	—
k_{hfp}	basic crown gear dedendum factor (related to m_{mn})	—
k_t	circular thickness factor	—
m_{et}	outer transverse module	mm
m_{mn}	mean normal module	mm
n_1	pinion speed	min ⁻¹
P	power	kW
R_{e1}, R_{e2}	outer cone distance	mm
R_{i1}, R_{i2}	inner cone distance	mm
R_{m1}, R_{m2}	mean cone distance	mm
r_{c0}	cutter radius	mm
s_{mn1}, s_{mn2}	mean normal circular tooth thickness	mm
s_{mnc1}, s_{mnc2}	mean normal chordal tooth thickness	mm
T_1	pinion torque	Nm
t_{xi1}, t_{xi2}	front crown to crossing point	mm
t_{xo1}, t_{xo2}	pitch cone apex to crown (crown to crossing point, hypoid)	mm
t_{z1}, t_{z2}	pitch apex beyond crossing point	mm
t_{zF1}, t_{zF2}	face apex beyond crossing point	mm
t_{zi1}, t_{zi2}	crossing point to inside point along axis	mm
t_{zm1}, t_{zm2}	crossing point to mean point along axis	mm
t_{zR1}, t_{zR2}	root apex beyond crossing point	mm
u	gear ratio	—
u_a	equivalent ratio	—
W_{m2}	wheel mean slot width	mm
x_{hm1}	profile shift coefficient	—
x_{sm1}, x_{sm2}	thickness modification coefficient (backlash included)	—
x_{smn}	thickness modification coefficient (theoretical)	—
Z_0	number of blade groups	—
Z_1, Z_2	number of teeth	—
Z_p	number of crown gear teeth	—
α_{dC}	nominal design pressure angle on coast side	°
α_{dD}	nominal design pressure angle on drive side	°
α_{eC}	effective pressure angle on coast side	°
α_{eD}	effective pressure angle on drive side	°
α_{nD}	generated pressure angle on drive side	°
α_{nC}	generated pressure angle on coast side	°
α_{lim}	limit pressure angle	°
β_{e1}, β_{e2}	outer spiral angle	°
β_{i1}, β_{i2}	inner spiral angle	°
β_{m1}, β_{m2}	mean spiral angle	°
Δb_{x1}	pinion face width increment	mm

Table 1 (continued)

Symbol	Description	Unit
Δg_{xi}	increment along pinion axis from calculation point to inside	mm
Δg_{xe}	increment along pinion axis from calculation point to outside	mm
$\Delta \Sigma$	shaft angle departure from 90°	°
δ_{a1}, δ_{a2}	face angle	°
δ_{f1}, δ_{f2}	root angle	°
δ_1, δ_2	pitch angle	°
ε_{β}	face contact ratio	-
η	wheel offset angle in axial plane	°
θ_{a1}, θ_{a2}	addendum angle	°
θ_{f1}, θ_{f2}	dedendum angle	°
ν	lead angle of cutter	°
ρ_b	epicycloid base circle radius	mm
ρ_{lim}	limit curvature radius	mm
ρ_{P0}	crown gear to cutter centre distance	mm
Σ	shaft angle	°
$\Sigma\theta_f$	sum of dedendum angles	°
$\Sigma\theta_{fC}$	sum of dedendum angles for constant slot width taper	°
$\Sigma\theta_{fS}$	sum of dedendum angles for standard taper	°
$\Sigma\theta_{fM}$	sum of dedendum angles for modified slot width taper	°
$\Sigma\theta_{fU}$	sum of dedendum angles for uniform depth taper	°
ζ_o	pinion offset angle in face plane	°
ζ_m	pinion offset angle in axial plane	°
ζ_{mp}	offset angle in pitch plane, pinion and wheel	°
ζ_R	pinion offset angle in root plane	°

4 Design considerations

4.1 General

Loading, speed, accuracy requirements, space limitations and special operating conditions influence the design. For details, see ISO 10300 (all parts), [Annex B](#) and handbooks of gear manufacturing companies.

“Precision finish”, as used in this document, refers to a machine finishing operation which includes grinding, skiving and hard cut finishing. However, the common form of finishing known as “lapping” is specifically excluded as a form of precision finishing.

Users should determine the cutting methods available from their gear manufacturer prior to proceeding. Cutting systems used by bevel gear manufacturers are heavily dependent upon the type of machine tool that will be used.

4.2 Types of bevel gears

4.2.1 General

Bevel gears are suitable for transmitting power between shafts at practically any angle or speed. However, the particular type of gear best suited for a specific application is dependent upon the mountings, available space and operating conditions.

4.2.2 Straight bevels

Straight bevel gears (see [Figure 4](#)) are the simplest form of bevel gears. Contact on the driven gear begins at the top of the tooth and progresses towards the root. They have teeth which are straight and tapered which, if extended inward, generally intersect in a common point at the axis.

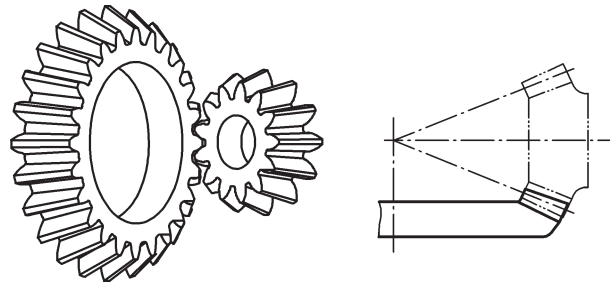

Figure 4 — Straight bevel

4.2.3 Spiral bevels

Spiral bevel gears (see [Figure 5](#)) have curved oblique teeth on which contact begins at one end of the tooth and progresses smoothly to the other end. They mesh with contact similar to straight bevels but as the result of additional overlapping tooth action, the motion will be transmitted more smoothly than by straight bevel or zerol bevel gears. This reduces noise and vibration especially noticeable at high speeds. Spiral bevel gears can also have their tooth surfaces precision-finished.

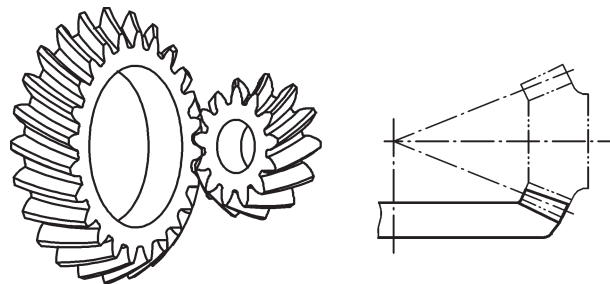

Figure 5 — Spiral bevel

4.2.4 Zerol bevels

Zerol bevel gears (see [Figure 6](#)), as well as other spiral bevel gears, with zero spiral angle have curved teeth which are in the same general direction as straight bevel teeth. They produce the same thrust loads on the bearings, can be used in the same mounting, have smooth operating characteristics and are manufactured on the same machines as spiral bevel gears. Zerol bevels can also have their tooth surfaces precision-finished. Gears with spiral angles less than 10° are sometimes referred to by the name “zerol”.

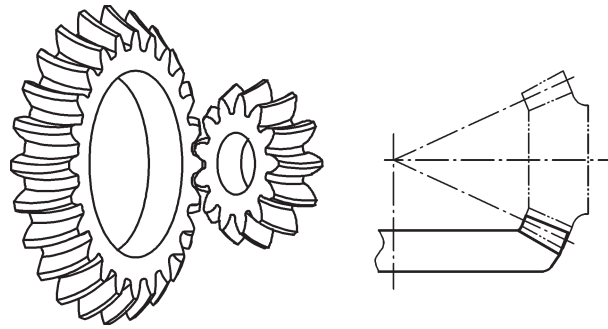

Figure 6 — Zerol bevel

4.2.5 Hypoids

Hypoid gears (see [Figure 7](#)) are similar to spiral bevel gears except that the pinion axis is offset above or below the wheel axis; see [B.3](#). If there is sufficient offset, the shafts may pass one another and a compact straddle mounting can be used on the wheel and pinion. Hypoid gears can also have their tooth surfaces precision-finished.

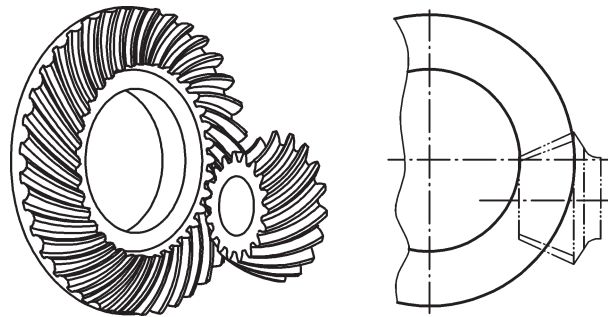

Figure 7 — Hypoid

4.3 Ratios

Bevel gears may be used for both speed-reducing and speed-increasing drives. The required ratio shall be determined by the designer from the given input speed and required output speed. For power drives, the ratio in bevel and hypoid gears may be as low as 1, but should not exceed approximately 10. High-ratio hypoids from 10 to approximately 20 have found considerable usage in machine tool design where precision gears are required. In speed-increasing applications, the ratio should not exceed 5.

4.4 Hand of spiral

The hand of spiral should be selected to give an axial thrust that tends to move both the wheel and pinion out of mesh when operating in the predominant working direction.

Often, the mounting conditions will dictate the hand of spiral to be selected. For spiral bevel and hypoid gears, both members should be held against axial movement in both directions.

A *right-hand spiral bevel gear* is one in which the outer half of a tooth is inclined in the clockwise direction from the axial plane through the midpoint of the tooth as viewed by an observer looking at the face of the gear. [Figure 5](#) shows a right-hand wheel.

A *left-hand spiral bevel gear* is one in which the outer half of a tooth is inclined in the anticlockwise (counterclockwise) direction from the axial plane through the midpoint of the tooth as viewed by an observer looking at the face of the gear. [Figure 5](#) shows a left-hand pinion.

To avoid the loss of backlash, the hand of spiral should be selected to give an axial thrust that tends to move the pinion out of mesh. See [Annex D](#).

For relation of the hand of spiral and the direction of hypoid offset, see [B.3](#).

4.5 Preliminary gear size

Once the preliminary gear size is determined (see [B.4.3](#)), the tooth proportions of the gears should be established and the resulting design should be checked for bending strength and pitting resistance. See ISO 10300 (all parts).

5 Tooth geometry and cutting considerations

5.1 Manufacturing considerations

This clause presents tooth dimensions for bevel and hypoid gears in which the teeth are machined by a face mill cutter, face hob cutter, a planing tool or a cup-shaped grinding wheel. The gear geometry is a function of the cutting method used. For this reason, it is important that the user is familiar with the cutting methods used by the gear manufacturer. The following section is provided to familiarize the user with this interdependence.

5.2 Tooth taper

Bevel gear tooth design involves some consideration of tooth taper because the amount of taper affects the final tooth proportions and the size and shape of the blank.

It is advisable to define the following interrelated basic types of tapers (these are illustrated in [Figure 8](#), in which straight bevel teeth are shown for simplicity).

- Depth taper refers to the change in tooth depth along the face measured perpendicular to the pitch cone.
- Slot width taper refers to the change in the point width formed by a V-shaped cutting tool of nominal pressure angle, whose sides are tangent to the two sides of the tooth space and whose top is tangent to the root cone, along the face.
- Space width taper refers to the change in the space width along the face. It is generally measured in the pitch plane.
- Thickness taper refers to the change in tooth thickness along the face. It is generally measured in the pitch plane.

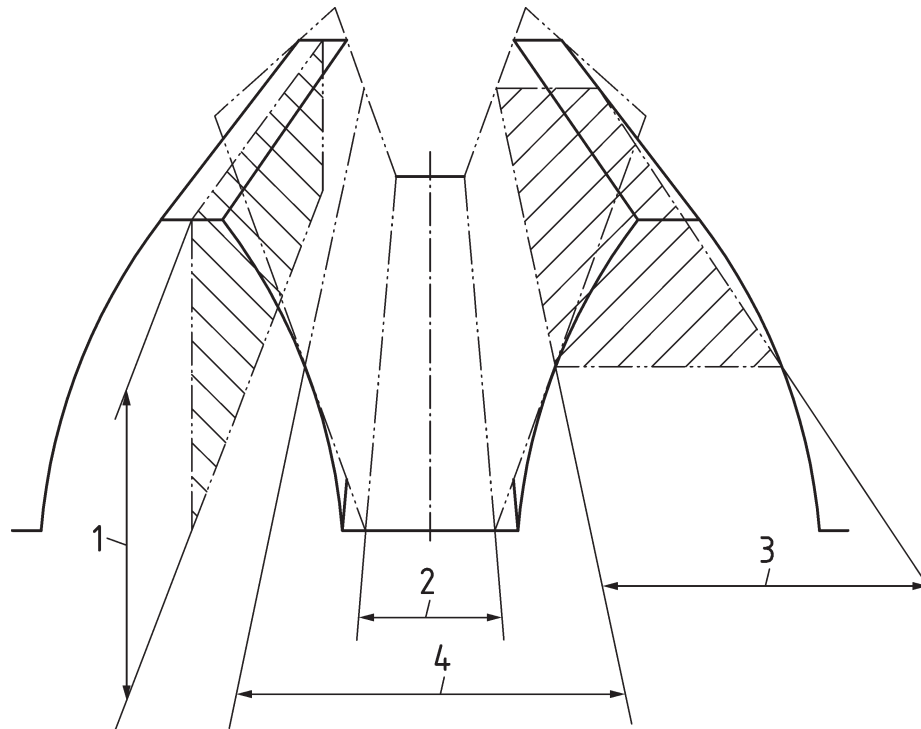

Key

- 1 depth
- 2 slot width
- 3 thickness
- 4 space width

Figure 8 — Bevel gear tooth tapers

The taper of primary consideration for production is the slot width taper. The width of the slot at its narrowest point determines the point width of the cutting tool and limits the edge radius that can be placed on the cutter blade.

The taper which directly affects the blank is the depth taper through its effect on the dedendum angle, which is used in the calculation of the face angle of the mating member.

The slot width taper depends upon the lengthwise curvature and the dedendum angle. It can be changed by varying the depth taper, i.e. by tilting the root line as shown in [Figure 9](#), in which the concept is simplified by illustrating straight bevel teeth. In spiral bevel and hypoid gears, the amount by which the root line is tilted is further dependent upon a number of geometric characteristics including the cutter radius.

This relationship is discussed more thoroughly in [5.3](#).

The root line is generally rotated about the mid-section at the pitch line in order to maintain the desired working depth at the mean section of the tooth.

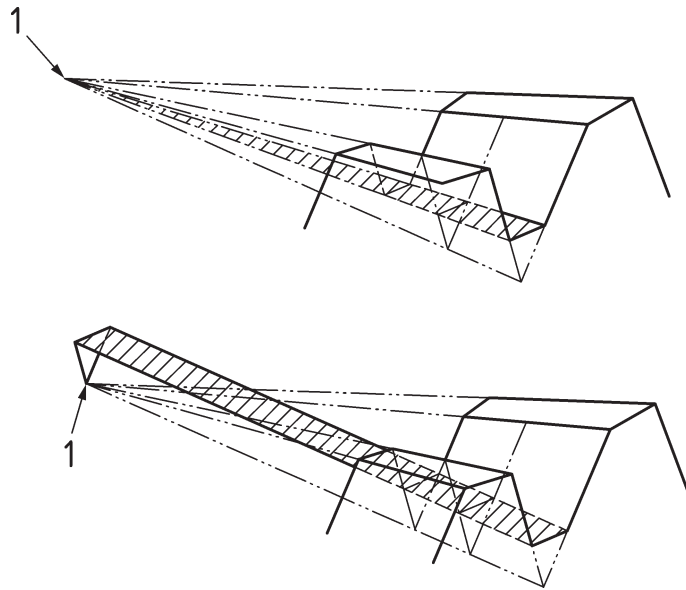

Key

1 pitch cone apex

Figure 9 — Root line tilt

5.3 Tooth depth configurations

5.3.1 Taper depth

5.3.1.1 Standard depth

Standard depth pertains to the configuration where the depth changes in proportion to the cone distance at any particular section of the tooth. If the root line of such a tooth is extended, it intersects the axis at the pitch cone apex, as illustrated in [Figure 10](#), but the face cone apex does not. The sum of the dedendum angles of pinion and wheel for standard depth taper, $\Sigma\theta_{fS}$, does not depend on cutter radius. Most straight bevel gears are designed with standard depth taper.

5.3.1.2 Constant slot width

This taper represents a tilt of the root line such that the slot width is constant while maintaining the proper space width taper. The slot width taper is zero on both members.

The formula for the sum of the dedendum angles is given in [C.5.1](#).

Formula (C.4), for the sum of the dedendum angles, indicates that the cutter radius, r_{c0} , has a significant effect on the amount by which the root line is tilted. For a given design, the following tendencies should be noted.

- A large cutter radius increases the sum of the dedendum angles. If the radius is too large, the resultant depthwise taper could adversely affect the depth of the teeth at either end, i.e. too shallow at inner end for proper tooth contact, and too deep at the outer end, which can cause undercut and narrow toplands. Therefore, the cutter radius should not be too large and an upper limit of r_{c0} approximately equal to R_{m2} is suggested.
- A small cutter radius decreases the sum of the dedendum angles. In fact, if r_{c0} equals $R_{m2} \sin \beta_{m2}$, the sum of the dedendum angles becomes zero, which results in uniform depth teeth. If r_{c0} is less than $R_{m2} \sin \beta_{m2}$, reverse depthwise taper would exist and the teeth would be deeper at the inner

end than at the outer. In order to avoid excessive depth (undercut and narrow toplands) at the inner end, a minimum value of r_{c0} , equal to $1,1 R_{m2} \sin \beta_{m2}$, is suggested.

NOTE For gears cut with a planing tool, the cutter centre is considered to be at infinity and root lines are not tilted. Standard taper is the norm for gears produced in this manner.

5.3.1.3 Modified slot width

This taper is an intermediate one in which the root line is tilted about the mean point. In this case, the slot width of the gear member is constant along the tooth length and any slot width taper is on the pinion member.

For the case where the root line is tilted to permit finishing the gear in one operation, the amount of tilt is somewhat arbitrary, but should fall within the following guidelines (see [Table C.4](#)):

- the sum of the pinion and wheel dedendum angles for modified slot width taper, $\Sigma\theta_{fM}$, should not exceed 1,3 times the sum of the dedendum angles for standard depth taper, $\Sigma\theta_{fS}$, nor should it exceed the sum of the dedendum angles for constant slot width taper, $\Sigma\theta_{fC}$;
- in practice, the smaller of the values, $1,3 \Sigma\theta_{fS}$ or $\Sigma\theta_{fC}$, is used.

5.3.2 Uniform depth

Uniform depth is the configuration where the tooth depth remains constant along the face width regardless of cutter radius. In this case, the root line is parallel to an element of the face cone, as illustrated in [Figure 10](#). The sum of the dedendum angles of pinion and wheel for uniform depth, $\Sigma\theta_{fU}$, equals zero.

For the uniform depth tooth, the cutter radius, r_{c0} , should be greater than $R_{m2} \sin \beta_{m2}$, but not more than 1,5 times this value. This approximation of lengthwise involute curvature, in conjunction with the uniform depth, holds the variation along the face width in normal circular thickness on the pinion and wheel to a minimum.

If narrow inner toplands occur on the pinion, a small tooth tip chamfer may be provided (see [Figure 11](#)).

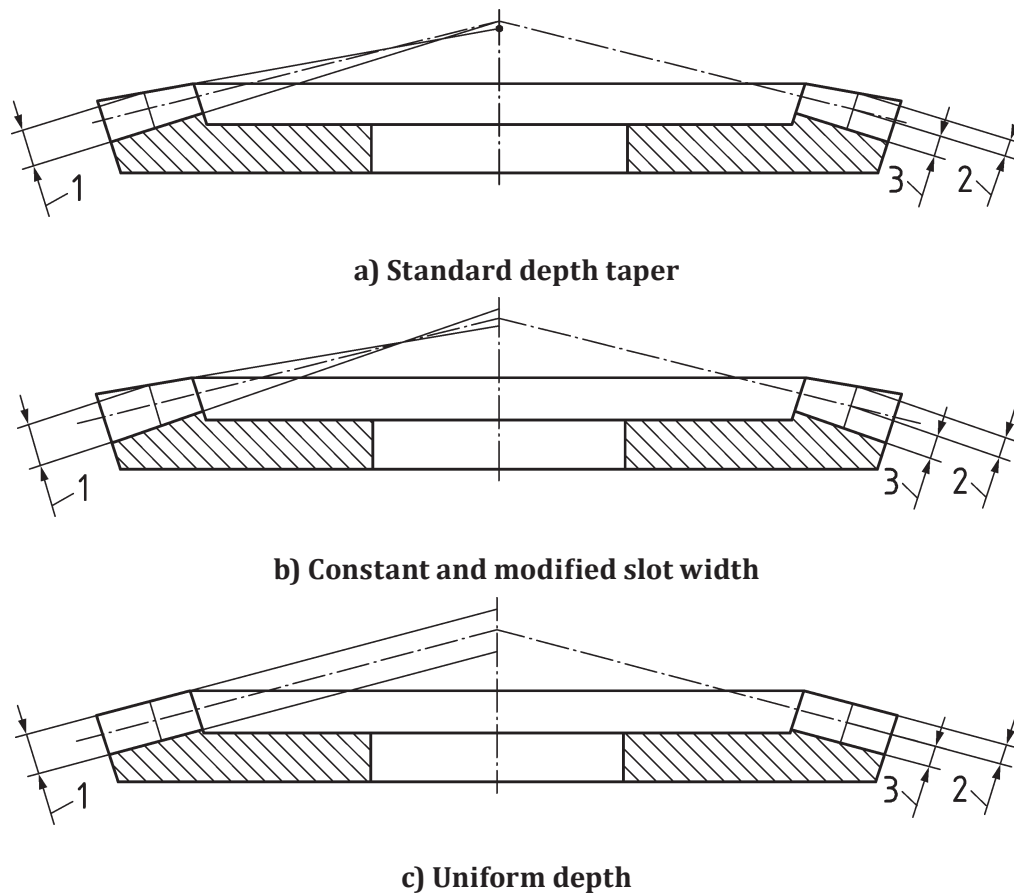

- Key**
- 1 mean whole depth
 - 2 mean addendum
 - 3 mean dedendum

Figure 10 — Bevel gear depthwise tapers

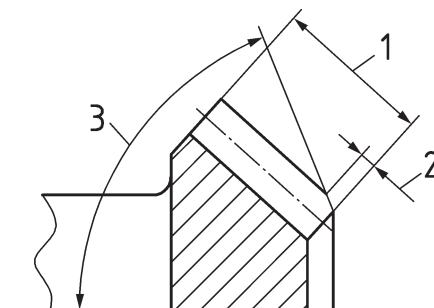

- Key**
- 1 face width, b_1
 - 2 length of chamfer
 - 3 angle of chamfer

Figure 11 — Tooth tip chamfering on the pinion

5.4 Dedendum angle modifications

To avoid cutter interference with a hub or shoulder, the wheel and pinion root line can be rotated about the mean point as shown in [Figure 12](#). A dedendum angle modification, when desired, normally ranges between -5° and $+5^\circ$.

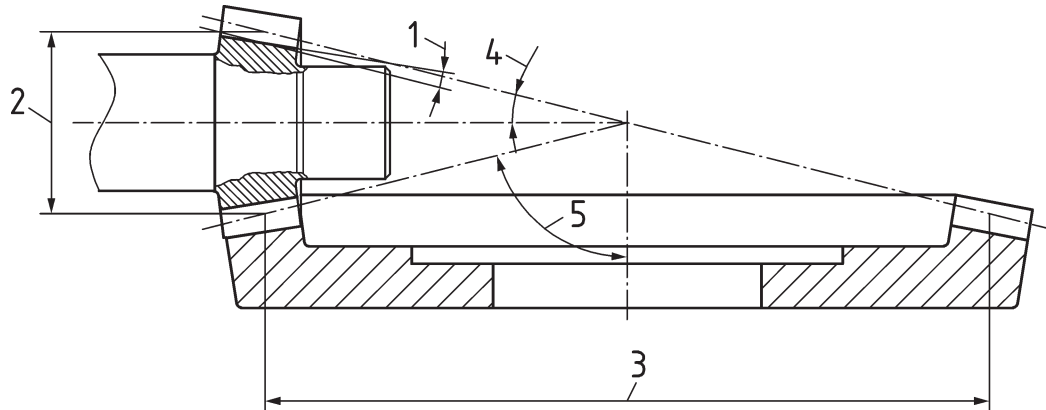

Key

- 1 dedendum angle modification
- 2 mean pitch diameter of pinion, d_{m1}
- 3 mean pitch diameter of wheel, d_{m2}
- 4 pitch angle of pinion, δ_1
- 5 pitch angle of wheel, δ_2

Figure 12 — Angle modification required because of extension in pinion shaft

5.5 Cutter radius

Most spiral bevel gears are manufactured with face cutters. The selection of the cutter radius depends on the cutting system used. A list of nominal cutter radii is contained in [Annex E](#).

5.6 Mean radius of curvature

Two types of cutting processes are used in the industry. In the process which will be referred to as the “face milling process”, the cradle axis and the work axis roll together in a timed relationship. In the process which will be referred to as the “face hobbing process”, the cradle axis, work axis and cutter axis roll together in a timed relationship.

With the face milling process, the mean radius of tooth curvature is equal to the cutter radius [see [Figure 13 a](#))].

With the face hobbing process, the curve in the lengthwise direction of the tooth is an extended epicycloid and is a function of the relative roll between the workpiece and the cutter. The radius of curvature is somewhat smaller than the cutter radius.

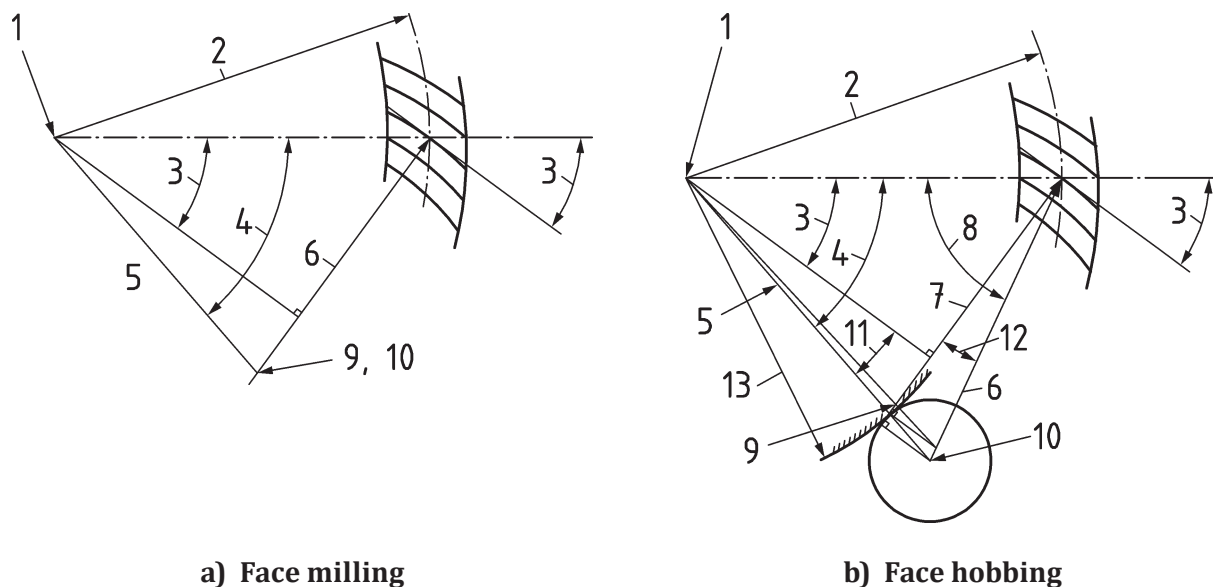

a) Face milling

b) Face hobbing

Key

- | | |
|--|--|
| 1 crown gear centre | 8 first auxiliary angle, λ |
| 2 mean cone distance, R_{m2} | 9 centre of curvature |
| 3 spiral angle, β_{m2} | 10 cutter centre |
| 4 intermediate angle | 11 second auxiliary angle, η_1 |
| 5 crown gear to cutter centre, ρ_{p0} | 12 lead angle of cutter, ν |
| 6 cutter radius, r_{c0} | 13 epicycloid base circle radius, ρ_b |
| 7 lengthwise tooth mean radius of curvature, $\rho_{m\beta}$ | |

Figure 13 — Geometry of face milling and face hobbing processes

5.7 Hypoid design

An infinite number of pitch surfaces exists for any hypoid pair. However, starting with the initial data given in Table 2, the result is only one pitch surface for each method. The design procedures used in the industry will be referred to as Method 1, Method 2 and Method 3, and, for bevel gears, as Method 0.

In Method 1 and Method 3, the pitch surfaces are selected such that the hypoid radius of curvature matches the cutter radius of curvature at the mean point for gears to be manufactured by the face milling process and such that it matches the mean epicycloidal curvature at the mean point for gears cut by the face hobbing process.

Method 2 is a method for designing gears to be cut by the face hobbing process. In this case, the wheel pitch apex, pinion pitch apex and cutter centre lie on a straight line.

5.8 Most general type of gearing

Hypoid gears are the most general type of gearing. The wheel and pinion axes are skew and non-intersecting. The teeth are curved in the lengthwise direction. All other types of gears can be considered subsets of the hypoid. Spiral bevel gears are hypoid gears with zero offset between the axes. Straight bevel gears are hypoid gears with zero offset and zero tooth curvature. Helical gears are hypoid gears with zero shaft angle and zero tooth curvature.

5.9 Hypoid geometry

5.9.1 Basics

Whenever a most general case is defined, the definition becomes complex. Hypoid gear geometry is no exception. [Figure 14](#) shows the major angles and quantities involved. [Figure 14 a\)](#) is a side view looking along the pinion axis. [Figure 14 b\)](#) is a front view looking along the wheel axis. [Figure 14 c\)](#) is a top view showing the shaft angle between the wheel and pinion axes. [Figure 14 d\)](#) is a view of the wheel section along the plane making the offset angle, key 16, in the pinion axial plane. [Figure 14 e\)](#) is a view of the pitch plane. [Figure 14 f\)](#) is a view of the pinion section along the plane making the offset angle, key 2, in the wheel axial plane.

The scope of this document does not permit an adequate explanation or derivation of the formulae involved.

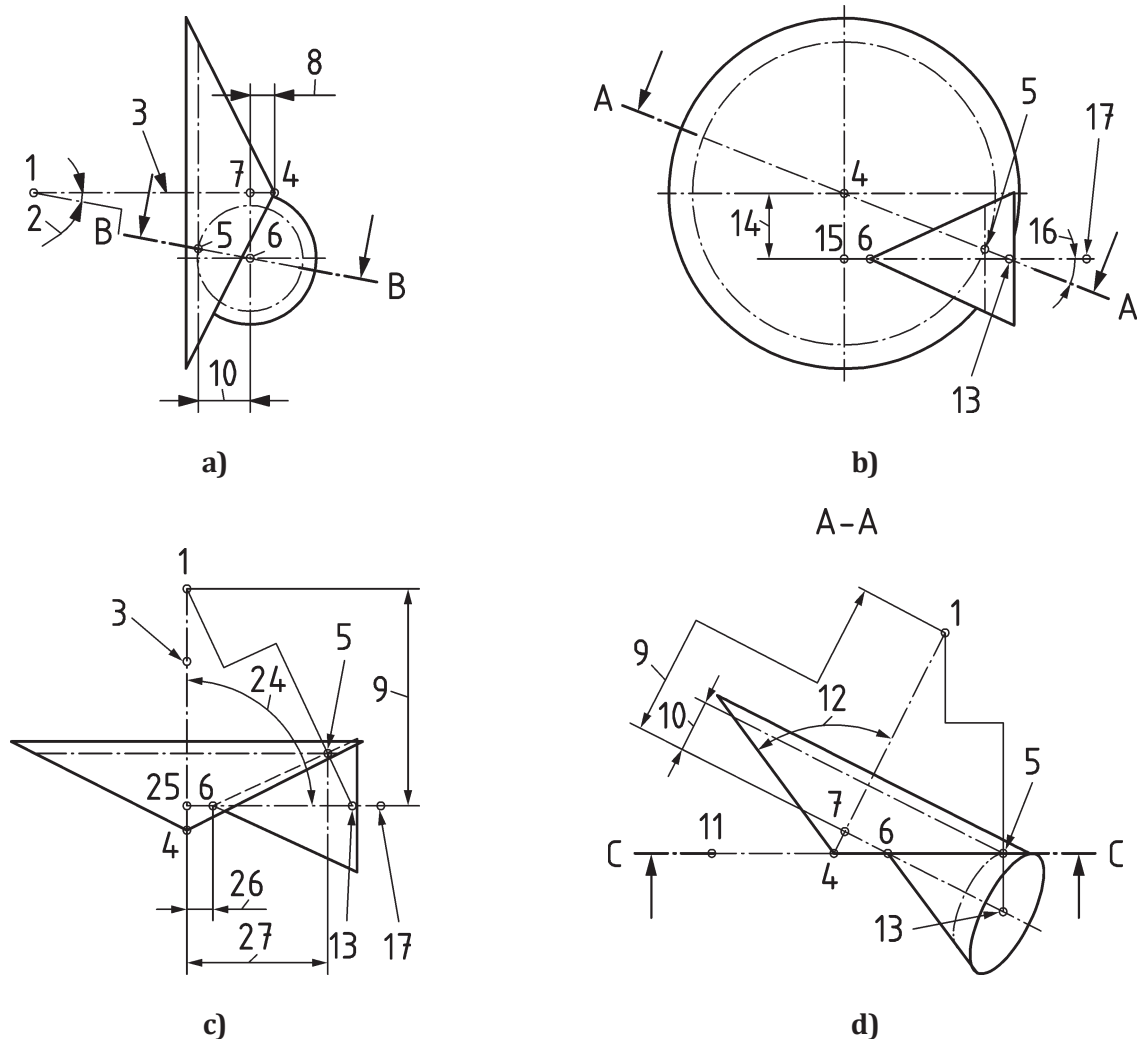

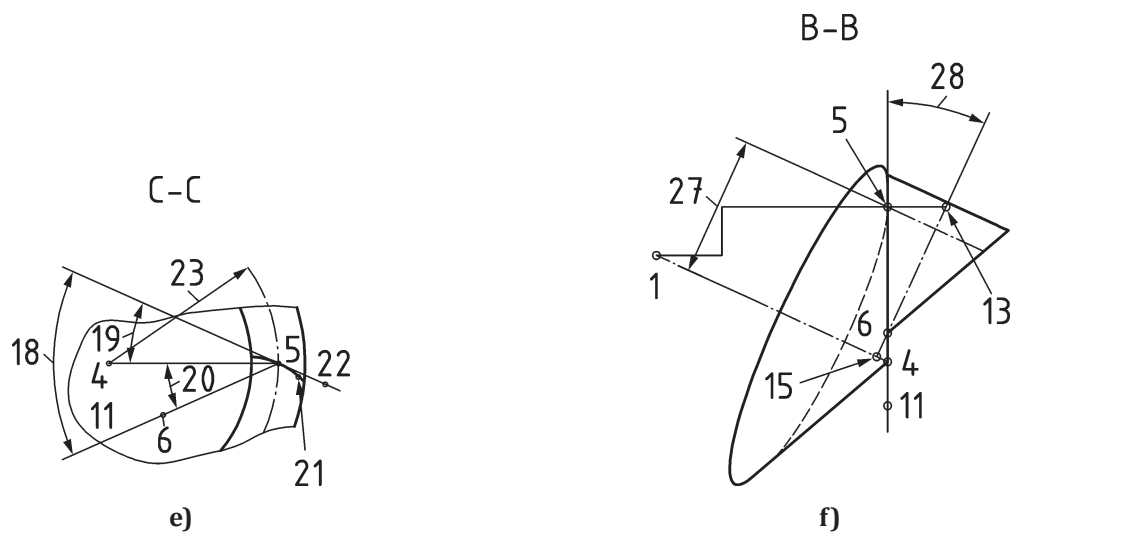

Key

1	intersection of contact normal through mean point at wheels axis	10	crossing point to mean point along wheel axis, t_{zm2}	20	offset angle in pitch plane, pinion and wheel, ζ_{mp}
2	wheel offset angle in axial plane, η	11	pitch plane	21	sliding velocity vector
3	wheel axis	12	wheel pitch angle, δ_2	22	tangent to tooth trace at mean point
4	wheel pitch apex	13	intersection point of contact normal through mean point at pinion axis	23	wheel mean cone distance, R_{m2}
5	mean point, P	14	offset, a	24	shaft angle, Σ
6	pinion pitch apex	15	crossing point at pinion axis	25	common normal to pinion and wheel axis through crossing point
7	crossing point at wheel axis	16	pinion offset angle in axial plane, ζ_m	26	pinion pitch apex beyond crossing point, t_{z1}
8	wheel pitch apex beyond crossing point, t_{z2}	17	pinion axis	27	crossing point to mean point along pinion axis, t_{zm1}
9	distance along wheel axis between crossing point and contact normal intersection	18	pinion spiral angle, β_{m1}	28	pinion pitch angle, δ_1
		19	wheel spiral angle, β_{m2}	29	pinion mean cone distance, R_{m1}

Figure 14 — Hypoid geometry

5.9.2 Crossing point

Crossing point, O_C , is the point of intersection of bevel gear axes; it is also the apparent point of intersection of axes in hypoid gears, when projected to a plane parallel to both axes (see [Figure 15](#)).

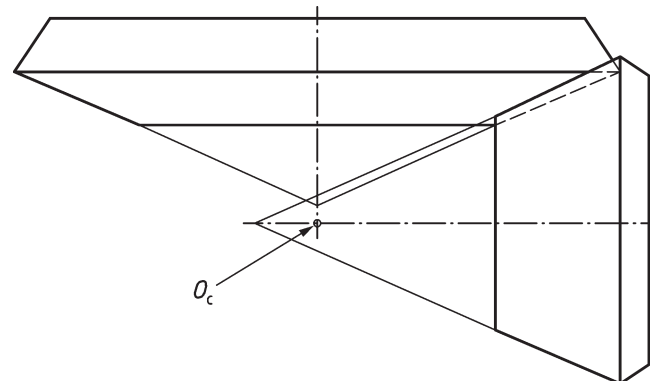

Figure 15 — Crossing point for hypoid gears

6 Pitch cone parameters

6.1 Initial data for pitch cone parameters

The recommended procedure in this document is to begin each method with the calculation of the pitch cone parameters; see [Annex A](#). For the calculation of the pitch cone parameters, a set of initial data is necessary, as given in [Table 2](#).

Table 2 — Initial data for pitch cone parameters

Symbol	Description	Method 0	Method 1	Method 2	Method 3
Σ	shaft angle	X	X	X	X
a	hypoid offset	0,0	X	X	X
$z_{1,2}$	number of teeth	X	X	X	X
d_{m2}	mean pitch diameter of wheel	—	—	X	—
d_{e2}	outer pitch diameter of wheel	X	X	—	X
b_2	wheel face width	X	X	X	X
β_{m1}	mean spiral angle of pinion	—	X	—	—
β_{m2}	mean spiral angle of wheel	X	—	X	X
r_{c0}	cutter radius	X	X	X	X
z_0	number of blade groups (only face hobbing)	X	X	X	X

[Annex A](#) provides a structure for calculating the methods provided in this document.

6.2 Determination of pitch cone parameters for bevel and hypoid gears

6.2.1 Method 0

Gear ratio, u

$$u = \frac{z_2}{z_1} \quad (1)$$

Pinion pitch angle, δ_1

$$\delta_1 = \arctan\left(\frac{\sin\Sigma}{\cos\Sigma + u}\right) \quad (2)$$

Wheel pitch angle, δ_2

$$\delta_2 = \Sigma - \delta_1 \quad (3)$$

Outer cone distance, R_e

$$R_{e1,2} = \frac{d_{e2}}{2\sin\delta_2} \quad (4)$$

Mean cone distance, R_m

$$R_{m1,2} = R_{e2} - \frac{b_2}{2} \quad (5)$$

Spiral angle, β_{m1} , pinion

$$\beta_{m1} = \beta_{m2} \quad (6)$$

Face width factor, c_{be2}

$$c_{be2} = 0,5 \quad (7)$$

6.2.2 Method 1

Gear ratio, u

$$u = \frac{z_2}{z_1} \quad (8)$$

Desired pinion spiral angle, $\beta_{\Delta 1}$, pinion

$$\beta_{\Delta 1} = \beta_{m1} \quad (9)$$

Shaft angle departure from 90°, $\Delta\Sigma$

$$\Delta\Sigma = \Sigma - 90^\circ \quad (10)$$

Approximate wheel pitch angle, $\delta_{\text{int}2}$

$$\delta_{\text{int}2} = \arctan \left(\frac{u \cos \Delta \Sigma}{1,2(1 - u \sin \Delta \Sigma)} \right) \quad (11)$$

Wheel mean pitch radius, $r_{\text{mpt}2}$

$$r_{\text{mpt}2} = \frac{d_{e2} - b_2 \sin \delta_{\text{int}2}}{2} \quad (12)$$

Approximate pinion offset angle in pitch plane, ε'_i

$$\varepsilon'_i = \arcsin \left(\frac{a \sin \delta_{\text{int}2}}{r_{\text{mpt}2}} \right) \quad (13)$$

Approximate hypoid dimension factor, K_1

$$K_1 = \tan \beta_{\Delta 1} \sin \varepsilon'_i + \cos \varepsilon'_i \quad (14)$$

Approximate pinion mean radius, $r_{\text{mn}1}$

$$r_{\text{mn}1} = \frac{r_{\text{mpt}2} K_1}{u} \quad (15)$$

Start of iteration

Wheel offset angle in axial plane, η

$$\eta = \arctan \left[\frac{a}{r_{\text{mpt}2} (\tan \delta_{\text{int}2} \cos \Delta \Sigma - \sin \Delta \Sigma) + r_{\text{mn}1}} \right] \quad (16)$$

Intermediate pinion offset angle in axial plane, ε_2

$$\varepsilon_2 = \arcsin \left(\frac{a - r_{\text{mn}1} \sin \eta}{r_{\text{mpt}2}} \right) \quad (17)$$

Intermediate pinion pitch angle, $\delta_{\text{int}1}$

$$\delta_{\text{int}1} = \arctan \left(\frac{\sin \eta}{\tan \varepsilon_2 \cos \Delta \Sigma} + \tan \Delta \Sigma \cos \eta \right) \quad (18)$$

Intermediate pinion offset angle in pitch plane, ε'_2

$$\varepsilon'_2 = \arcsin \left(\frac{\sin \varepsilon_2 \cos \Delta \Sigma}{\cos \delta_{\text{int}1}} \right) \quad (19)$$

Intermediate pinion mean spiral angle, $\beta_{m,int1}$

$$\beta_{m,int1} = \arctan\left(\frac{K_1 - \cos\varepsilon'_2}{\sin\varepsilon'_2}\right) \quad (20)$$

Increment in hypoid dimension factor, ΔK

$$\Delta K = \sin\varepsilon'_2 \left(\tan\beta_{\Delta 1} - \tan\beta_{m,int1} \right) \quad (21)$$

Pinion mean radius increment, Δr_{mpt1}

$$\Delta r_{mpt1} = r_{mpt2} \frac{\Delta K}{u} \quad (22)$$

Pinion offset angle in axial plane, ε_1

$$\varepsilon_1 = \arcsin\left(\sin\varepsilon_2 - \frac{\Delta r_{mpt1}}{r_{mpt2}} \sin\eta\right) \quad (23)$$

Pinion pitch angle, δ_1

$$\delta_1 = \arctan\left(\frac{\sin\eta}{\tan\varepsilon_1 \cos\Delta\Sigma} + \tan\Delta\Sigma \cos\eta\right) \quad (24)$$

Pinion offset angle in pitch plane, ε'_1

$$\varepsilon'_1 = \arcsin\left(\frac{\sin\varepsilon_1 \cos\Delta\Sigma}{\cos\delta_1}\right) \quad (25)$$

Spiral angle, β_{m1} , pinion

$$\beta_{m1} = \arctan\left(\frac{K_1 + \Delta K - \cos\varepsilon'_1}{\sin\varepsilon'_1}\right) \quad (26)$$

Spiral angle, β_{m2} , wheel

$$\beta_{m2} = \beta_{m1} - \varepsilon'_1 \quad (27)$$

Wheel pitch angle, δ_2

$$\delta_2 = \arctan\left(\frac{\sin\varepsilon_1}{\tan\eta \cos\Delta\Sigma} + \cos\varepsilon_1 \tan\Delta\Sigma\right) \quad (28)$$

Mean cone distance, R_{m1} , pinion

$$R_{m1} = \frac{r_{mn1} + \Delta r_{mpt1}}{\sin\delta_1} \quad (29)$$

Mean cone distance, R_{m2} , wheel

$$R_{m2} = \frac{r_{mpt2}}{\sin\delta_2} \quad (30)$$

Mean pinion radius, r_{mpt1}

$$r_{mpt1} = R_{m1} \sin \delta_1 \quad (31)$$

Limit pressure angle, α_{lim}

$$\alpha_{lim} = \arctan \left[- \frac{\tan \delta_1 \tan \delta_2}{\cos \varepsilon'_1} \left(\frac{R_{m1} \sin \beta_{m1} - R_{m2} \sin \beta_{m2}}{R_{m1} \tan \delta_1 + R_{m2} \tan \delta_2} \right) \right] \quad (32)$$

Limit radius of curvature, ρ_{lim}

$$\rho_{lim} = \frac{\sec \alpha_{lim} (\tan \beta_{m1} - \tan \beta_{m2})}{- \tan \alpha_{lim} \left(\frac{\tan \beta_{m1}}{R_{m1} \tan \delta_1} + \frac{\tan \beta_{m2}}{R_{m2} \tan \delta_2} \right) + \frac{1}{R_{m1} \cos \beta_{m1}} - \frac{1}{R_{m2} \cos \beta_{m2}}} \quad (33)$$

For face hobbled gears:

Number of crown gear teeth, z_p

$$z_p = \frac{z_2}{\sin \delta_2} \quad (34)$$

Lead angle of cutter, ν

$$\nu = \arcsin \left(\frac{R_{m2} z_0}{r_{c0} z_p} \cos \beta_{m2} \right) \quad (35)$$

First auxiliary angle, λ

$$\lambda = 90^\circ - \beta_{m2} + \nu \quad (36)$$

Crown gear to cutter centre distance, ρ_{p0}

$$\rho_{p0} = \sqrt{R_{m2}^2 + r_{c0}^2 - 2R_{m2} r_{c0} \cos \lambda} \quad (37)$$

Second auxiliary angle, η_1

$$\eta_1 = \arccos \left[\frac{R_{m2} \cos \beta_{m2}}{\rho_{p0} z_p} (z_p + z_0) \right] \quad (38)$$

Lengthwise tooth mean radius of curvature, $\rho_{m\beta}$

$$\rho_{m\beta} = R_{m2} \cos \beta_{m2} \left[\tan \beta_{m2} + \frac{\tan \eta_1}{1 + \tan \nu (\tan \beta_{m2} + \tan \eta_1)} \right] \quad (39)$$

For face milled gears:

Lengthwise tooth mean radius of curvature, $\rho_{m\beta}$

$$\rho_{m\beta} = r_{c0} \quad (40)$$

Change η and recalculate from [Formula \(17\)](#) to [Formula \(33\)](#) until $\frac{\rho_{m\beta}}{\rho_{lim}} - 1 \leq 0,01$

End of iteration

Face width factor, c_{be2}

$$c_{be2} = \frac{\frac{d_{e2}}{2\sin\delta_2} - R_{m2}}{b_2} \quad (41)$$

6.2.3 Method 2

Lead angle of cutter, ν (see [Figure 13](#))

$$\nu = \arcsin\left(\frac{z_0 d_{m2} \cos\beta_{m2}}{2z_2 r_{c0}}\right) \quad (42)$$

First auxiliary angle, λ

$$\lambda = 90^\circ - \beta_{m2} + \nu \quad (43)$$

Gear ratio, u

$$u = \frac{z_2}{z_1} \quad (44)$$

First approximate pinion pitch angle, δ_{1app}

$$\delta_{1app} = \arctan\left(\frac{\sin\Sigma}{u + \cos\Sigma}\right) \quad (45)$$

First approximate wheel pitch angle, δ_{2app}

$$\delta_{2app} = \Sigma - \delta_{1app} \quad (46)$$

First approximate pinion offset angle in axial plane, ζ_{mapp}

$$\zeta_{mapp} = \arcsin\left(\frac{\frac{2a}{d_{m2}}}{1 + \frac{\cos\delta_{2app}}{u \cos\delta_{1app}}}\right) \quad (47)$$

Approximate hypoid dimension factor, F_{app}

$$F_{\text{app}} = \frac{\cos\beta_{m2}}{\cos(\beta_{m2} + \zeta_{\text{mapp}})} \quad (48)$$

Approximate pinion mean pitch diameter, $d_{m1\text{app}}$

$$d_{m1\text{app}} = \frac{F_{\text{app}} d_{m2}}{u} \quad (49)$$

Intermediate angle, φ_2

$$\varphi_2 = \arctan \left[\frac{u \cos\zeta_{\text{mapp}}}{\frac{u}{\tan\delta_{2\text{app}}} + (F_{\text{app}} - 1) \sin\Sigma} \right] \quad (50)$$

Approximate mean radius of crown gear, R_{mapp}

$$R_{\text{mapp}} = \frac{d_{m2}}{2\sin\varphi_2} \quad (51)$$

Second auxiliary angle, η_1 (see [Figure 13](#))

$$\eta_1 = \arctan \left(\frac{r_{c0} \cos\nu - R_{\text{mapp}} \sin\beta_{m2}}{r_{c0} \sin\nu + R_{\text{mapp}} \cos\beta_{m2}} \right) \quad (52)$$

Intermediate angle, φ_3

$$\varphi_3 = \arctan \left[\frac{\tan(\beta_{m2} + \eta_1)}{\sin\varphi_2} \right] \quad (53)$$

Second approximate pinion pitch angle, δ_1''

$$\delta_1'' = \arctan \left[\frac{d_{m1\text{app}} \sin\Sigma}{d_{m2} \cos\zeta_{\text{mapp}} + d_{m1\text{app}} \cos\Sigma - \frac{2a}{\tan(\varphi_3 + \zeta_{\text{mapp}})}} \right] \quad (54)$$

Approximate wheel pitch angle, δ_2'' , projected into pinion axial plane along the common pitch plane (see [Figure 14](#))

$$\delta_2'' = \Sigma - \delta_1'' \quad (55)$$

Start of iteration

Improved wheel pitch angle, $\delta_{2\text{imp}}$

$$\delta_{2\text{imp}} = \arctan \left(\tan \delta_2'' \cos \zeta_{\text{mapp}} \right) \quad (56)$$

Auxiliary angle, η_p

$$\eta_p = \arctan \left[\frac{\sin \zeta_{\text{mapp}} \cos \delta_{2\text{imp}}}{\cos (\Sigma - \delta_{2\text{imp}})} \right] \quad (57)$$

Approximate wheel offset angle, η_{app}

$$\eta_{\text{app}} = \arctan \left[\frac{2a}{d_{m2} \tan \delta_{2\text{imp}} + d_{m1\text{app}} \frac{\cos \eta_p \sin (\beta_{m2} + \eta_1)}{\cos (\Sigma - \delta_{2\text{imp}})}} \right] \quad (58)$$

Improved pinion offset angle in axial plane, $\zeta_{m\text{imp}}$

$$\zeta_{m\text{imp}} = \arcsin \left[\frac{2a}{d_{m2}} - \frac{F_{\text{app}} \tan \eta_{\text{app}} \sin \delta_{2\text{imp}} \cos \eta_p}{u \cos (\Sigma - \delta_{2\text{imp}})} \right] \quad (59)$$

Improved pinion offset angle in pitch plane, $\zeta_{\text{mp imp}}$

$$\zeta_{\text{mp imp}} = \arctan \left[\frac{\tan \zeta_{m\text{imp}} \sin \Sigma}{\cos (\Sigma - \delta_{2\text{imp}})} \right] \quad (60)$$

Hypoid dimension factor, F

$$F = \frac{\cos \beta_{m2}}{\cos (\beta_{m2} + \zeta_{\text{mp imp}})} \quad (61)$$

Pinion mean pitch diameter, d_{m1}

$$d_{m1} = \frac{F d_{m2}}{u} \quad (62)$$

Intermediate angle, φ_4

$$\varphi_4 = \arctan \left(\frac{\sin \lambda \sin \Sigma}{\frac{d_{m2}}{2r_{c0}} - \cos \lambda \sin \delta_{2\text{imp}}} \right) \quad (63)$$

Improved pinion pitch angle, $\delta_1''_{\text{imp}}$

$$\delta_1''_{\text{imp}} = \arctan \left[\frac{d_{m1} \sin \Sigma}{d_{m2} \cos \zeta_{m \text{ imp}} + d_{m1} \cos \Sigma \cos \eta_p - \frac{2a}{\tan(\varphi_4 + \zeta_{m \text{ imp}})}} \right] \quad (64)$$

Improved wheel pitch angle, projected into pinion axial plane along the common pitch plane, $\delta_2''_{\text{imp}}$

$$\delta_2''_{\text{imp}} = \Sigma - \delta_1''_{\text{imp}} \quad (65)$$

Wheel pitch angle, δ_2

$$\delta_2 = \arctan \left(\tan \delta_2''_{\text{imp}} \cos \zeta_{m \text{ imp}} \right) \quad (66)$$

Intermediate angle, φ_5

$$\varphi_5 = \arctan \left(\frac{\tan \delta_2}{\cos \zeta_{m \text{ imp}}} \right) \quad (67)$$

Improved auxiliary angle, η_{pimp}

$$\eta_{\text{pimp}} = \arctan \left[\frac{\tan \eta_{\text{app}} \sin \varphi_5}{\cos(\Sigma - \varphi_5)} \right] \quad (68)$$

Wheel offset angle in axial plane, η

$$\eta = \arctan \left[\frac{2a}{d_{m2} \tan \delta_2 + d_{m1} \frac{\cos \eta_{\text{pimp}} \sin \varphi_5}{\cos(\Sigma - \varphi_5)}} \right] \quad (69)$$

Pinion offset angle in axial plane, ζ_m

$$\zeta_m = \arcsin(\tan \delta_2 \tan \eta) \quad (70)$$

Pinion offset angle in pitch plane, ζ_{mp}

$$\zeta_{\text{mp}} = \arctan \left[\frac{\tan \zeta_m \sin \Sigma}{\cos(\Sigma - \delta_2)} \right] \quad (71)$$

Pinion spiral angle, β_{m1}

$$\beta_{m1} = \beta_{m2} + \zeta_{\text{mp}} \quad (72)$$

Pinion mean pitch diameter, d_{m1}

$$d_{m1} = \frac{d_{m2} \cos \beta_{m2}}{u \cos \beta_{m1}} \quad (73)$$

Auxiliary angle, ξ

If $\Sigma \neq 90^\circ$:

$$\xi = \arctan\left(\tan\Sigma \cos\zeta_m\right) - \delta_2 \quad (74)$$

If $\Sigma = 90^\circ$:

$$\xi = 90^\circ - \delta_2 \quad (75)$$

Pinion pitch angle, δ_1

$$\delta_1 = \arctan\left(\tan\xi \cos\zeta_{mp}\right) \quad (76)$$

Mean cone distance, R_{m1} , pinion

$$R_{m1} = \frac{d_{m1}}{2\sin\delta_1} \quad (77)$$

Mean cone distance, R_{m2} , wheel

$$R_{m2} = \frac{d_{m2}}{2\sin\delta_2} \quad (78)$$

Crown gear to cutter centre distance, ρ_{p0}

$$\rho_{p0} = \sqrt{r_{c0}^2 + R_{m2}^2 - 2r_{c0} R_{m2} \cos\lambda} \quad (79)$$

Intermediate angle, φ_6

$$\varphi_6 = \arcsin\left(\frac{r_{c0}\sin\lambda}{\rho_{p0}}\right) \quad (80)$$

Complementary angle, φ_{comp}

$$\varphi_{comp} = 180^\circ - \zeta_{mp} - \varphi_6 \quad (81)$$

Checking variable, R_{mcheck}

$$R_{mcheck} = \frac{R_{m2}\sin\varphi_6}{\sin\varphi_{comp}} \quad (82)$$

Change δ_{2imp} [[Formula \(56\)](#)] and recalculate to [Formula \(82\)](#) until $\left| \frac{R_{m1}}{R_{mcheck}} - 1 \right| \leq 0,01$, increase δ_{2imp} , if $R_{m1} < R_{mcheck}$ and vice versa.

End of iteration

Face width factor, c_{be2}

$$c_{be2} = 0,5 \quad (83)$$

6.2.4 Method 3

Gear ratio, u

$$u = \frac{z_2}{z_1} \quad (84)$$

For the iteration that follows, start with hypoid dimension factor, F

$$F = 1 \quad (85)$$

Wheel pitch angle, δ_2

$$\delta_2 = \arctan \left(\frac{\sin \Sigma}{\frac{F}{u} + \cos \Sigma} \right) \quad (86)$$

Pinion pitch angle, δ_1

$$\delta_1 = \Sigma - \delta_2 \quad (87)$$

Start of iteration

Wheel mean pitch diameter, d_{m2}

$$d_{m2} = d_{e2} - b_2 \sin \delta_2 \quad (88)$$

Pinion offset angle in axial plane, ζ_m

$$\zeta_m = \arcsin \left[\frac{2a}{d_{m2} \left(1 + \frac{F \cos \delta_2}{u \cos \delta_1} \right)} \right] \quad (89)$$

Pinion pitch angle, δ_1

$$\delta_1 = \arcsin \left(\cos \zeta_m \sin \Sigma \cos \delta_2 - \cos \Sigma \sin \delta_2 \right) \quad (90)$$

Pinion offset angle in pitch plane, ζ_{mp}

$$\zeta_{mp} = \arcsin \left(\frac{\sin \zeta_m \sin \Sigma}{\cos \delta_1} \right) \quad (91)$$

Mean normal module, m_{mn}

$$m_{mn} = \frac{\cos\beta_{m2} d_{m2}}{z_2} \quad (92)$$

Spiral angle, β_{m1} , pinion

$$\beta_{m1} = \beta_{m2} + \zeta_{mp} \quad (93)$$

Hypoid dimension factor, F

$$F = \frac{\cos\beta_{m2}}{\cos\beta_{m1}} \quad (94)$$

Pinion mean pitch diameter, d_{m1}

$$d_{m1} = \frac{d_{m2}}{u} F \quad (95)$$

Mean cone distance, R_{m1} , pinion

$$R_{m1} = \frac{d_{m1}}{2\sin\delta_1} \quad (96)$$

Mean cone distance, R_{m2} , wheel

$$R_{m2} = \frac{d_{m2}}{2\sin\delta_2} \quad (97)$$

Lead angle of cutter, ν

$$\nu = \arcsin\left(\frac{z_0 m_{mn}}{2r_{c0}}\right) \quad (98)$$

Auxiliary angle, ϑ_m

$$\vartheta_m = \arctan(\sin\delta_2 \tan\zeta_m) \quad (99)$$

Intermediate variable, A_3

$$A_3 = r_{c0} \cos^2(\beta_{m2} - \nu) \quad (100)$$

Intermediate variable, A_4

$$A_4 = R_{m2} \cos(\beta_{m2} + \vartheta_m) \cos\beta_{m2} \quad (101)$$

Intermediate variable, A_5

$$A_5 = \sin\zeta_{mp} \cos\vartheta_m \cos\nu \quad (102)$$

Intermediate variable, A_6

$$A_6 = R_{m2} \cos\beta_{m2} + r_{c0} \sin\nu \quad (103)$$

Intermediate variable, A_7

$$A_7 = \cos\beta_{m1} \cos(\beta_{m2} + \vartheta_m) - \frac{\sin(\beta_{m2} + \vartheta_m - \nu) \sin\zeta_{mp}}{\cos(\beta_{m2} - \nu)} \quad (104)$$

Intermediate variable, $R_{m \text{ int}}$

$$R_{m \text{ int}} = \frac{A_3 A_4}{A_5 A_6 + A_3 A_7} \quad (105)$$

Check:

$$\left| R_{m \text{ int}} - R_{m1} \right| < 0,000 1 R_{m1} \quad (106)$$

Pinion pitch angle, δ_1

$$\delta_1 = \arcsin\left(\frac{d_{m1}}{2R_{m \text{ int}}}\right) \quad (107)$$

Wheel pitch angle, δ_2

$$\delta_2 = \arccos\left(\frac{\sin\delta_1 \cos\zeta_m \sin\Sigma + \cos\delta_1 \cos\zeta_{mp} \cos\Sigma}{1 - \sin^2\Sigma \sin^2\zeta_m}\right) \quad (108)$$

Repeat calculation from [Formula \(88\)](#) to [Formula \(108\)](#) until [Formula \(106\)](#) is true.

End of iteration

Face width factor, c_{be2}

$$c_{be2} = 0,5 \quad (109)$$

7 Gear dimensions

7.1 Initial data for tooth profile parameters

For the calculation of the gear dimensions, initial data for tooth profile parameters shown in [Table 3](#) are required in addition to the initial data for pitch cone parameters shown in [Table 2](#). The data in [Table 3](#) are defined at the calculation point of the wheel. Bevel and hypoid gear data may be supplied in either of the two commonly used forms: data type I or data type II; see [Table 3](#) and [Annex A](#).

Table 3 — Initial data for tooth profile parameters

Data type I		Data type II	
Symbol	Description	Symbol	Description
α_{dD}	nominal design pressure angle – drive side ^a		
α_{dC}	nominal design pressure angle – coast side ^a		
f_{alim}	influence factor of limit pressure angle ^a		
x_{hm1}	profile shift coefficient	c_{ham}	mean addendum factor of wheel
k_{hap}	basic crown gear addendum factor	k_d	depth factor
k_{hfp}	basic crown gear dedendum factor	k_c	clearance factor
x_{smn}	thickness modification coefficient	k_t W_{m2}	thickness factor or wheel mean slot width
$j_{mn}, j_{mt2},$ j_{en}, j_{et2}	backlash (choice of four)		
θ_{a2}	addendum angle of wheel		
θ_{f2}	dedendum angle of wheel		

^a Generally, drive and coast side pressure angles are balanced in initial design. However, some applications may be optimized with unbalanced pressure angles; see [Annex C](#) for guidance.

[Annex C](#) gives suggestions for the data in [Table 3](#).

Data type II can be directly transformed into data type I and vice versa. [Table 4](#) shows the appropriate formulae.

Table 4 — Conversions between data type I and data type II

Conversion of data type II to data type I	Conversion of data type I to data type II
$x_{hm1} = k_d \left(\frac{1}{2} - c_{ham} \right)$	$c_{ham} = \frac{1}{2} \left(1 - \frac{x_{hm1}}{k_{hap}} \right)$
$k_{hap} = \frac{k_d}{2}$	$k_d = 2 k_{hap}$
$k_{hfp} = k_d \left(k_c + \frac{1}{2} \right)$	$k_c = \frac{1}{2} \left(\frac{k_{hfp}}{k_{hap}} - 1 \right)$
$x_{smn} = \frac{k_t}{2} = \frac{1}{2} \left[\frac{W_{m2}}{m_{mn}} + k_d \left(k_c + \frac{1}{2} \right) \left(\tan \alpha_{nD} + \tan \alpha_{nC} \right) - \frac{\pi}{2} \right]$	$k_t = 2 x_{smn}$

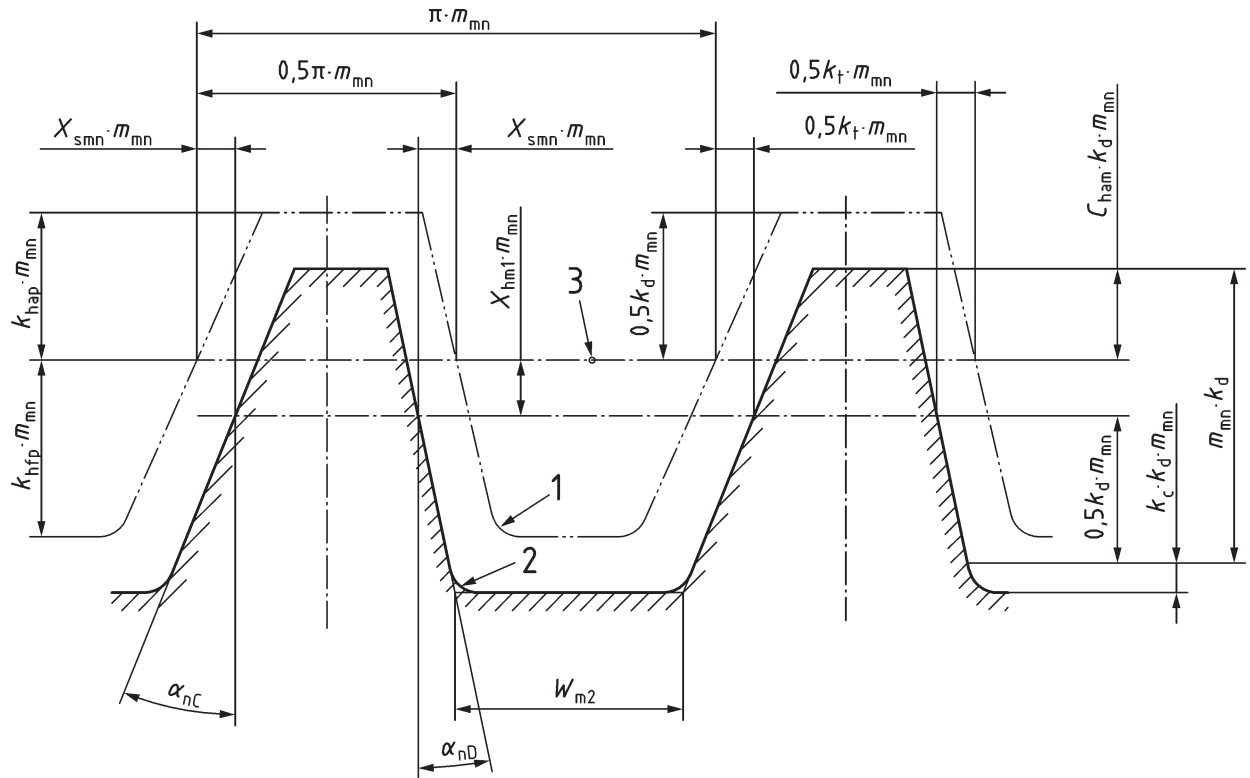

Key

- 1 basic rack tooth profile
- 2 tooth profile with profile shift and thickness modification
- 3 reference line

Figure 16 — Basic rack tooth profile of wheel at calculation point

7.2 Determination of basic data

Pinion mean pitch diameter, d_{m1}

$$d_{m1} = 2R_{m1} \sin \delta_1 \quad (110)$$

Wheel mean pitch diameter, d_{m2}

$$d_{m2} = 2R_{m2} \sin \delta_2 \quad (111)$$

Shaft angle departure from 90° , $\Delta\Sigma$

$$\Delta\Sigma = \Sigma - 90^\circ \quad (112)$$

Offset angle in the pinion axial plane, ζ_m

$$\zeta_m = \arcsin \left(\frac{2a}{d_{m2} + d_{m1} \frac{\cos \delta_2}{\cos \delta_1}} \right) \quad (113)$$

Offset angle in the pitch plane, ζ_{mp}

$$\zeta_{mp} = \arcsin \left(\frac{\sin \zeta_m \sin \Sigma}{\cos \delta_1} \right) \quad (114)$$

Offset in pitch plane, a_p

$$a_p = R_{m2} \sin \zeta_{mp} \quad (115)$$

Mean normal module, m_{mn}

$$m_{mn} = \frac{2R_{m2} \sin \delta_2 \cos \beta_{m2}}{z_2} \quad (116)$$

Limit pressure angle, α_{lim}

$$\alpha_{lim} = - \arctan \left[\frac{\tan \delta_1 \tan \delta_2 \left(\frac{R_{m1} \sin \beta_{m1} - R_{m2} \sin \beta_{m2}}{R_{m1} \tan \delta_1 + R_{m2} \tan \delta_2} \right)}{\cos \zeta_{mp}} \right] \quad (117)$$

Generated normal pressure angle, α_{nD} , drive side

$$\alpha_{nD} = \alpha_{dD} + f_{\alpha_{lim}} \alpha_{lim} \quad (118)$$

Generated normal pressure angle, α_{nC} , coast side

$$\alpha_{nC} = \alpha_{dC} - f_{\alpha_{lim}} \alpha_{lim} \quad (119)$$

Effective pressure angle, α_{eD} , drive side

$$\alpha_{eD} = \alpha_{nD} - \alpha_{lim} \quad (120)$$

Effective pressure angle, α_{eC} , coast side

$$\alpha_{eC} = \alpha_{nC} + \alpha_{lim} \quad (121)$$

Outer pitch cone distance, R_{e2} , wheel

$$R_{e2} = R_{m2} + c_{be2} b_2 \quad (122)$$

Inner pitch cone distance, R_{i2} , wheel

$$R_{i2} = R_{e2} - b_2 \quad (123)$$

Outer pitch diameter, d_{e2} , wheel

$$d_{e2} = 2R_{e2} \sin \delta_2 \quad (124)$$

$$d_{i2} = 2R_{i2} \sin \delta_2 \quad (125)$$

Outer transverse module, m_{et2}

$$m_{et2} = \frac{d_{e2}}{z_2} \quad (126)$$

Wheel face width from calculation point to outside, b_{e2}

$$b_{e2} = R_{e2} - R_{m2} \quad (127)$$

Wheel face width from calculation point to inside, b_{i2}

$$b_{i2} = R_{m2} - R_{i2} \quad (128)$$

Crossing point to calculation point along wheel axis, t_{zm2}

$$t_{zm2} = \frac{d_{m1} \sin \delta_2}{2 \cos \delta_1} - 0,5 \cos \zeta_m \tan \Delta \Sigma \left(d_{m2} + \frac{d_{m1} \cos \delta_2}{\cos \delta_1} \right) \quad (129)$$

Crossing point to calculation point along pinion axis, t_{zm1}

$$t_{zm1} = \frac{d_{m2}}{2} \cos \zeta_m \cos \Delta \Sigma - t_{zm2} \sin \Delta \Sigma \quad (130)$$

Pitch apex beyond crossing point along axis, $t_{z1,2}$

$$t_{z1,2} = R_{m1,2} \cos \delta_{1,2} - t_{zm1,2} \quad (131)$$

7.3 Determination of tooth depth at calculation point

Mean working depth, h_{mw}

$$h_{mw} = 2m_{mn} k_{hap} \quad (132)$$

Mean addendum, h_{am2} , wheel

$$h_{am2} = m_{mn} (k_{hap} - x_{hm1}) \quad (133)$$

Mean dedendum, h_{fm2} , wheel

$$h_{fm2} = m_{mn} (k_{hfp} + x_{hm1}) \quad (134)$$

Mean addendum, h_{am1} , pinion

$$h_{am1} = m_{mn} (k_{hap} + x_{hm1}) \quad (135)$$

Mean dedendum, h_{fm1} , pinion

$$h_{fm1} = m_{mn} (k_{hfp} - x_{hm1}) \quad (136)$$

Clearance, c

$$c = m_{mn} (k_{hfp} - k_{hap}) \quad (137)$$

Mean whole depth, h_m

$$h_m = h_{am1,2} + h_{fm1,2} \quad (138)$$

$$h_m = m_{mn} (k_{hap} + k_{hfp}) \quad (139)$$

7.4 Determination of root angles and face angles

Face angle, δ_{a2} , wheel

$$\delta_{a2} = \delta_2 + \theta_{a2} \quad (140)$$

Root angle, δ_{f2} , wheel

$$\delta_{f2} = \delta_2 - \theta_{f2} \quad (141)$$

Auxiliary angle for calculating pinion offset angle in root plane, φ_R

$$\varphi_R = \arctan \left(\frac{a \tan \Delta \Sigma \cos \delta_{f2}}{R_{m2} \cos \theta_{f2} - t_{z2} \cos \delta_{f2}} \right) \quad (142)$$

Auxiliary angle for calculating pinion offset angle in face plane, φ_o

$$\varphi_o = \arctan \left(\frac{a \tan \Delta \Sigma \cos \delta_{a2}}{R_{m2} \cos \theta_{a2} - t_{z2} \cos \delta_{a2}} \right) \quad (143)$$

Pinion offset angle in root plane, ζ_R

$$\zeta_R = \arcsin \left(\frac{a \cos \varphi_R \sin \delta_{f2}}{R_{m2} \cos \theta_{f2} - t_{z2} \cos \delta_{f2}} \right) - \varphi_R \quad (144)$$

Pinion offset angle in face plane, ζ_o

$$\zeta_o = \arcsin \left(\frac{a \cos \varphi_o \sin \delta_{a2}}{R_{m2} \cos \theta_{a2} - t_{z2} \cos \delta_{a2}} \right) - \varphi_o \quad (145)$$

Face angle, δ_{a1} , pinion

$$\delta_{a1} = \arcsin \left(\sin \Delta \Sigma \sin \delta_{f2} + \cos \Delta \Sigma \cos \delta_{f2} \cos \zeta_R \right) \quad (146)$$

Root angle, δ_{f1} , pinion

$$\delta_{f1} = \arcsin \left(\sin \Delta \Sigma \sin \delta_{a2} + \cos \Delta \Sigma \cos \delta_{a2} \cos \zeta_o \right) \quad (147)$$

Addendum angle, θ_{a1} , pinion

$$\theta_{a1} = \delta_{a1} - \delta_1 \quad (148)$$

Dedendum angle, θ_{f1} , pinion

$$\theta_{f1} = \delta_1 - \delta_{f1} \quad (149)$$

Wheel face apex beyond crossing point along wheel axis, t_{zF2}

$$t_{zF2} = t_{z2} - \frac{R_{m2} \sin \theta_{a2} - h_{am2} \cos \theta_{a2}}{\sin \delta_{a2}} \quad (150)$$

Wheel root apex beyond crossing point along wheel axis, t_{zR2}

$$t_{zR2} = t_{z2} + \frac{R_{m2} \sin \theta_{f2} - h_{fm2} \cos \theta_{f2}}{\sin \delta_{f2}} \quad (151)$$

Pinion face apex beyond crossing point along pinion axis, t_{zF1}

$$t_{zF1} = \frac{a \sin \zeta_R \cos \delta_{f2} - t_{zR2} \sin \delta_{f2} - c}{\sin \delta_{a1}} \quad (152)$$

Pinion root apex beyond crossing point along pinion axis, t_{zR1}

$$t_{zR1} = \frac{a \sin \zeta_o \cos \delta_{a2} - t_{zF2} \sin \delta_{a2} - c}{\sin \delta_{f1}} \quad (153)$$

7.5 Determination of pinion face width, b_1

Pinion face width in pitch plane, b_{p1}

$$b_{p1} = \sqrt{R_{e2}^2 - a_p^2} - \sqrt{R_{i2}^2 - a_p^2} \quad (154)$$

Pinion face width from calculation point to front crown, b_{1A}

$$b_{1A} = \sqrt{R_{m2}^2 - a_p^2} - \sqrt{R_{i2}^2 - a_p^2} \quad (155)$$

Method 0:

Pinion face width, b_1

$$b_1 = b_2 \quad (156)$$

Pinion face width from calculation point to outside, b_{e1}

$$b_{e1} = c_{be2} b_1 \quad (157)$$

Pinion face width from calculation point to inside, b_{i1}

$$b_{i1} = b_1 - b_{e1} \quad (158)$$

Method 1:

Auxiliary angle, λ'

$$\lambda' = \arctan\left(\frac{\sin\zeta_{mp} \cos\delta_2}{u \cos\delta_1 + \cos\delta_2 \cos\zeta_{mp}}\right) \quad (159)$$

Pinion face width, b_{reri1}

$$b_{reri1} = \frac{b_2 \cos\lambda'}{\cos(\zeta_{mp} - \lambda')} \quad (160)$$

Pinion face width increment along pinion axis, Δb_{x1}

$$\Delta b_{x1} = h_{mw} \sin\zeta_R \left(1 - \frac{1}{u}\right) \quad (161)$$

Increment along pinion axis from calculation point to outside, Δg_{xe}

$$\Delta g_{xe} = \frac{c_{be2} b_{reri1}}{\cos\theta_{a1}} \cos\delta_{a1} + \Delta b_{x1} - (h_{fm2} - c) \sin\delta_1 \quad (162)$$

Increment along pinion axis from calculation point to inside, Δg_{xi}

$$\Delta g_{xi} = \frac{(1 - c_{be2}) b_{reri1}}{\cos \theta_{a1}} \cos \delta_{a1} + \Delta b_{x1} + (h_{fm2} - c) \sin \delta_1 \quad (163)$$

Pinion face width from calculation point to outside, b_{e1}

$$b_{e1} = \frac{\Delta g_{xe} + h_{am1} \sin \delta_1}{\cos \delta_{a1}} \cos \theta_{a1} \quad (164)$$

Pinion face width from calculation point to inside, b_{i1}

$$b_{i1} = \frac{\Delta g_{xi} - h_{am1} \sin \delta_1}{\cos \delta_1 - \tan \theta_{a1} \sin \delta_1} \quad (165)$$

Pinion face width along pitch cone, b_1

$$b_1 = b_{i1} + b_{e1} \quad (166)$$

Method 2:

Pinion face width along pitch cone, b_1

$$b_1 = b_2 \left(1 + \tan^2 \zeta_{mp} \right) \quad (167)$$

Pinion face width from calculation point to outside, b_{e1}

$$b_{e1} = c_{be2} b_1 \quad (168)$$

Pinion face width from calculation point to inside, b_{i1}

$$b_{i1} = b_1 - b_{e1} \quad (169)$$

Method 3:

Pinion face width along pitch cone, b_1

$$b_1 = \text{int} \left(b_{p1} + 3 m_{mn} \tan \left| \zeta_{mp} \right| + 1 \right) \quad (170)$$

Additional pinion face width, b_x

$$b_x = \frac{b_1 - b_{p1}}{2} \quad (171)$$

Pinion face width from calculation point to inside, b_{i1}

$$b_{i1} = b_{1A} + b_x \quad (172)$$

Pinion face width from calculation point to outside, b_{e1}

$$b_{e1} = b_1 - b_{i1} \quad (173)$$

7.6 Determination of inner and outer spiral angles

7.6.1 Pinion

Wheel cone distance of outer pinion boundary point, R_{e21} (may be larger than R_{e2})

$$R_{e21} = \sqrt{R_{m2}^2 + b_{e1}^2 + 2R_{m2} b_{e1} \cos \zeta_{mp}} \quad (174)$$

Wheel cone distance of inner pinion boundary point, R_{i21} (may be smaller than R_{i2})

$$R_{i21} = \sqrt{R_{m2}^2 + b_{i1}^2 - 2R_{m2} b_{i1} \cos \zeta_{mp}} \quad (175)$$

Face hobbing:

Lead angle of cutter, ν

$$\nu = \arcsin \left(\frac{z_0 m_{mn}}{2r_{c0}} \right) \quad (176)$$

Crown gear to cutter centre distance, ρ_{P0}

$$\rho_{P0} = \sqrt{R_{m2}^2 + r_{c0}^2 - 2R_{m2} r_{c0} \sin(\beta_{m2} - \nu)} \quad (177)$$

Epicycloid base circle radius, ρ_b

$$\rho_b = \frac{\rho_{P0}}{1 + \frac{z_0}{z_2} \sin \delta_2} \quad (178)$$

Auxiliary angle, φ_{e21}

$$\varphi_{e21} = \arccos \left(\frac{R_{e21}^2 + \rho_{P0}^2 - r_{c0}^2}{2R_{e21} \rho_{P0}} \right) \quad (179)$$

Auxiliary angle, φ_{i21}

$$\varphi_{i21} = \arccos \left(\frac{R_{i21}^2 + \rho_{P0}^2 - r_{c0}^2}{2R_{i21} \rho_{P0}} \right) \quad (180)$$

Wheel spiral angle at outer boundary point, β_{e21}

$$\beta_{e21} = \arctan \left(\frac{R_{e21} - \rho_b \cos \varphi_{e21}}{\rho_b \sin \varphi_{e21}} \right) \quad (181)$$

Wheel spiral angle at inner boundary point, β_{i21}

$$\beta_{i21} = \arctan \left(\frac{R_{i21} - \rho_b \cos \varphi_{i21}}{\rho_b \sin \varphi_{i21}} \right) \quad (182)$$

Face milling:

Wheel spiral angle at outer boundary point, β_{e21}

$$\beta_{e21} = \arcsin \left(\frac{2R_{m2} r_{c0} \sin \beta_{m2} - R_{m2}^2 + R_{e21}^2}{2R_{e21} r_{c0}} \right) \quad (183)$$

Wheel spiral angle at inner boundary point, β_{i21}

$$\beta_{i21} = \arcsin \left(\frac{2R_{m2} r_{c0} \sin \beta_{m2} - R_{m2}^2 + R_{i21}^2}{2R_{i21} r_{c0}} \right) \quad (184)$$

Face hobbing and face milling:

Pinion offset angle in pitch plane at outer boundary point, ζ_{ep21}

$$\zeta_{ep21} = \arcsin \left(\frac{a_p}{R_{e21}} \right) \quad (185)$$

Pinion offset angle in pitch plane at inner boundary point, ζ_{ip21}

$$\zeta_{ip21} = \arcsin \left(\frac{a_p}{R_{i21}} \right) \quad (186)$$

Outer pinion spiral angle, β_{e1}

$$\beta_{e1} = \beta_{e21} + \zeta_{ep21} \quad (187)$$

Inner pinion spiral angle, β_{i1}

$$\beta_{i1} = \beta_{i21} + \zeta_{ip21} \quad (188)$$

7.6.2 Wheel

Face hobbing:

Auxiliary angle, φ_{e2}

$$\varphi_{e2} = \arccos \left(\frac{R_{e2}^2 + \rho_{P0}^2 - r_{c0}^2}{2R_{e2} \rho_{P0}} \right) \quad (189)$$

Auxiliary angle, φ_{i2}

$$\varphi_{i2} = \arccos \left(\frac{R_{i2}^2 + \rho_{P0}^2 - r_{c0}^2}{2R_{i2} \rho_{P0}} \right) \quad (190)$$

Outer wheel spiral angle, β_{e2}

$$\beta_{e2} = \arctan \left(\frac{R_{e2} - \rho_b \cos \varphi_{e2}}{\rho_b \sin \varphi_{e2}} \right) \quad (191)$$

Inner wheel spiral angle, β_{i2}

$$\beta_{i2} = \arctan \left(\frac{R_{i2} - \rho_b \cos \varphi_{i2}}{\rho_b \sin \varphi_{i2}} \right) \quad (192)$$

Face milling:

Outer wheel spiral angle, β_{e2}

$$\beta_{e2} = \arcsin \left(\frac{2R_{m2} r_{c0} \sin \beta_{m2} - R_{m2}^2 + R_{e2}^2}{2R_{e2} r_{c0}} \right) \quad (193)$$

Inner wheel spiral angle, β_{i2}

$$\beta_{i2} = \arcsin \left(\frac{2R_{m2} r_{c0} \sin \beta_{m2} - R_{m2}^2 + R_{i2}^2}{2R_{i2} r_{c0}} \right) \quad (194)$$

7.7 Determination of tooth depth

Outer addendum, h_{ae}

$$h_{ae1,2} = h_{am1,2} + b_{e1,2} \tan \theta_{a1,2} \quad (195)$$

Outer dedendum, h_{fe}

$$h_{fe1,2} = h_{fm1,2} + b_{e1,2} \tan \theta_{f1,2} \quad (196)$$

Outer whole depth, h_e

$$h_{e1,2} = h_{ae1,2} + h_{fe1,2} \quad (197)$$

Inner addendum, h_{ai}

$$h_{ai1,2} = h_{am1,2} - b_{i1,2} \tan \theta_{a1,2} \quad (198)$$

Inner dedendum, h_{fi}

$$h_{fi1,2} = h_{fm1,2} - b_{i1,2} \tan \theta_{f1,2} \quad (199)$$

Inner whole depth, h_i

$$h_{i1,2} = h_{ai1,2} + h_{fi1,2} \quad (200)$$

7.8 Determination of tooth thickness

Mean normal pressure angle, α_n

$$\alpha_n = \frac{\alpha_{nD} + \alpha_{nC}}{2} \quad (201)$$

Thickness modification coefficient, x_{sm1} , pinion

with outer normal backlash, j_{en}

$$x_{sm1} = x_{smn} - j_{en} \frac{1}{4m_{mn} \cos\alpha_n} \frac{R_{m2} \cos\beta_{m2}}{R_{e2} \cos\beta_{e2}} \quad (202)$$

with outer transverse backlash, j_{et2}

$$x_{sm1} = x_{smn} - j_{et2} \frac{R_{m2} \cos\beta_{m2}}{4m_{mn} R_{e2}} \quad (203)$$

with mean normal backlash, j_{mn}

$$x_{sm1} = x_{smn} - j_{mn} \frac{1}{4m_{mn} \cos\alpha_n} \quad (204)$$

with mean transverse backlash, j_{mt2}

$$x_{sm1} = x_{smn} - j_{mt2} \frac{\cos\beta_{m2}}{4m_{mn}} \quad (205)$$

Mean normal circular tooth thickness, s_{mn1} , pinion

$$s_{mn1} = 0,5 m_{mn} \pi + 2 m_{mn} (x_{sm1} + x_{hm1} \tan\alpha_n) \quad (206)$$

Thickness modification coefficient, x_{sm2} , wheel

with outer normal backlash, j_{en}

$$x_{sm2} = -x_{smn} - j_{en} \frac{1}{4m_{mn} \cos\alpha_n} \frac{R_{m2} \cos\beta_{m2}}{R_{e2} \cos\beta_{e2}} \quad (207)$$

with outer transverse backlash, j_{et2}

$$x_{sm2} = -x_{smn} - j_{et2} \frac{R_{m2} \cos\beta_{m2}}{4m_{mn} R_{e2}} \quad (208)$$

with mean normal backlash, j_{mn}

$$x_{sm2} = -x_{smn} - j_{mn} \frac{1}{4m_{mn} \cos\alpha_n} \quad (209)$$

with mean transverse backlash, j_{mt2}

$$x_{sm2} = -x_{smn} - j_{mt2} \frac{\cos\beta_{m2}}{4m_{mn}} \quad (210)$$

Mean normal circular tooth thickness, s_{mn2} , wheel

$$s_{mn2} = 0,5 m_{mn} \pi + 2 m_{mn} (x_{sm2} - x_{hm1} \tan\alpha_n) \quad (211)$$

Mean transverse circular thickness, s_{mt}

$$s_{mt1,2} = s_{mn1,2} / \cos \beta_{m1,2} \quad (212)$$

Mean normal diameter, d_{mn}

$$d_{mn1,2} = \frac{d_{m1,2}}{\left(1 - \sin^2 \beta_{m1,2} \cos^2 \alpha_n\right) \cos \delta_{1,2}} \quad (213)$$

Mean normal chordal tooth thickness, s_{mnc}

$$s_{mnc1,2} = d_{mn1,2} \sin \left(s_{mn1,2} / d_{mn1,2} \right) \quad (214)$$

Mean chordal addendum, h_{amc}

$$h_{amc1,2} = h_{am1,2} + 0,5 d_{mn1,2} \cos \delta_{1,2} \left[1 - \cos \left(\frac{s_{mn1,2}}{d_{mn1,2}} \right) \right] \quad (215)$$

7.9 Determination of remaining dimensions

Outer pitch cone distance, R_{e1} , pinion

$$R_{e1} = R_{m1} + b_{e1} \quad (216)$$

Inner pitch cone distance, R_{i1} , pinion

$$R_{i1} = R_{m1} - b_{i1} \quad (217)$$

Outer pitch diameter, d_{e1} , pinion

$$d_{e1} = 2R_{e1} \sin \delta_1 \quad (218)$$

Inner pitch diameter, d_{i1} , pinion

$$d_{i1} = 2R_{i1} \sin \delta_1 \quad (219)$$

Outside diameter, d_{ae}

$$d_{ae1,2} = d_{e1,2} + 2h_{ae1,2} \cos \delta_{1,2} \quad (220)$$

Diameter, d_{fe}

$$d_{fe1,2} = d_{e1,2} - 2h_{fe1,2} \cos \delta_{1,2} \quad (221)$$

Diameter, d_{ai}

$$d_{ai1,2} = d_{i1,2} + 2h_{ai1,2} \cos \delta_{1,2} \quad (222)$$

Diameter, d_{fi}

$$d_{fi,2} = d_{i1,2} - 2h_{fi,2} \cos\delta_{1,2} \quad (223)$$

Crossing point to crown along axis, $t_{xo1,2}$

$$t_{xo1,2} = t_{zm1,2} + b_{e1,2} \cos\delta_{1,2} - h_{ae1,2} \sin\delta_{1,2} \quad (224)$$

Crossing point to front crown along axis, $t_{xi1,2}$

$$t_{xi1,2} = t_{zm1,2} - b_{i1,2} \cos\delta_{1,2} - h_{ai1,2} \sin\delta_{1,2} \quad (225)$$

Pinion whole depth, h_{t1} , perpendicular to the root cone

$$h_{t1} = \frac{t_{zF1} + t_{xo1}}{\cos\delta_{a1}} \sin(\theta_{a1} + \theta_{f1}) - (t_{zR1} - t_{zF1}) \sin\delta_{f1} \quad (226)$$

8 Undercut check

8.1 Pinion

Cone distance of the point to be checked, R_{x1} , pinion

$$R_{i1} \leq R_{x1} \leq R_e \quad (227)$$

Wheel cone distance of the appropriate pinion boundary point, R_{x2}
(may be smaller than R_{i2} and larger than R_{e2})

$$R_{x2} = \sqrt{R_{m2}^2 + (R_{m1} - R_{x1})^2 - 2R_{m2}(R_{m1} - R_{x1}) \cos\zeta_{mp}} \quad (228)$$

Face hobbing:

Auxiliary angle, φ_{x2}

$$\varphi_{x2} = \arccos\left(\frac{R_{x2}^2 + \rho_{P0}^2 - r_{c0}^2}{2R_{x2} \rho_{P0}}\right) \quad (229)$$

Wheel spiral angle at checkpoint, β_{x2}

$$\beta_{x2} = \arctan\left(\frac{R_{x2} - \rho_b \cos\varphi_{x2}}{\rho_b \sin\varphi_{x2}}\right) \quad (230)$$

Face milling:

Wheel spiral angle at checkpoint, β_{x2}

$$\beta_{x2} = \arcsin\left(\frac{2R_{m2} r_{c0} \sin\beta_{m2} - R_{m2}^2 + R_{x2}^2}{2R_{x2} r_{c0}}\right) \quad (231)$$

Face hobbing and face milling:

Pinion offset angle in pitch plane at checkpoint, ζ_{xp2}

$$\zeta_{xp2} = \arcsin\left(\frac{a_p}{R_{x2}}\right) \quad (232)$$

Pinion spiral angle at checkpoint, β_{x1}

$$\beta_{x1} = \beta_{x2} + \zeta_{xp2} \quad (233)$$

Pinion pitch diameter at checkpoint, d_{x1}

$$d_{x1} = 2R_{x1} \sin\delta_1 \quad (234)$$

Wheel pitch diameter at checkpoint, d_{x2}

$$d_{x2} = 2R_{x2} \sin\delta_2 \quad (235)$$

Normal module at checkpoint, m_{xn}

$$m_{xn} = \frac{d_{x2}}{z_2} \cos\beta_{x2} \quad (236)$$

Effective diameter at checkpoint, d_{Ex1} , pinion

$$d_{Ex1} = d_{x2} \frac{z_1 \cos\beta_{x2}}{z_2 \cos\beta_{x1}} \quad (237)$$

Appropriate cone distance, R_{Ex1}

$$R_{Ex1} = \frac{d_{Ex1}}{2\sin\delta_1} \quad (238)$$

Intermediate value, z_{nx1}

$$z_{nx1} = \frac{z_1}{\left(1 - \sin^2\beta_{x1} \cos^2\alpha_n\right) \cos\beta_{x1} \cos\delta_1} \quad (239)$$

Limit pressure angle at checkpoint, α_{limx}

$$\alpha_{limx} = -\arctan\left[\frac{\tan\delta_1 \tan\delta_2}{\cos\zeta_{mp}} \left(\frac{R_{Ex1} \sin\beta_{x1} - R_{x2} \sin\beta_{x2}}{R_{Ex1} \tan\delta_1 + R_{x2} \tan\delta_2}\right)\right] \quad (240)$$

Effective pressure angle at checkpoint, α_{eDx} , drive side

$$\alpha_{eDx} = \alpha_{nD} - \alpha_{limx} \quad (241)$$

Effective pressure angle at checkpoint, α_{eCx} , coast side

$$\alpha_{eCx} = \alpha_{nC} + \alpha_{limx} \quad (242)$$

For further calculations, choose the smaller effective pressure angle.

$$\text{If } \alpha_{eCx} < \alpha_{eDx}: \quad \alpha_{eminx} = \alpha_{eCx} \quad (243)$$

$$\text{If } \alpha_{eCx} \geq \alpha_{eDx}: \quad \alpha_{eminx} = \alpha_{eDx} \quad (244)$$

Determination of minimum profile shift coefficient at calculation point, $x_{hm \min x1}$, pinion:

Working tool addendum at checkpoint, k_{hapx}

$$k_{hapx} = k_{hap} + \frac{(R_{x2} - R_{m2}) \tan \theta_{a2}}{m_{mn}} \quad (245)$$

Minimum profile shift coefficient at checkpoint, x_{hx1} , pinion

$$x_{hx1} = 1,1 k_{hapx} - \frac{z_{nx1} m_{xn} \sin^2 \alpha_{eminx}}{2m_{mn}} \quad (246)$$

Minimum profile shift coefficient at calculation point, $x_{hm \min x1}$, pinion

$$x_{hm \min x1} = x_{hx1} + \frac{(d_{Ex1} - d_{x1}) \cos \delta_1}{2m_{mn}} \quad (247)$$

Undercut at checkpoint is avoided, if $x_{hm1} > x_{hm \min x1}$.

8.2 Wheel

Cone distance of the point to be checked, R_{x2} , wheel

$$R_{i2} \leq R_{x2} \leq R_e \quad (248)$$

Face hobbing:

Auxiliary angle, φ_{x2}

$$\varphi_{x2} = \arccos \left(\frac{R_{x2}^2 + \rho_{P0}^2 - r_{c0}^2}{2R_{x2} \rho_{P0}} \right) \quad (249)$$

Wheel spiral angle at checkpoint, β_{x2}

$$\beta_{x2} = \arctan \left(\frac{R_{x2} - \rho_b \cos \varphi_{x2}}{\rho_b \sin \varphi_{x2}} \right) \quad (250)$$

Face milling:

Wheel spiral angle at checkpoint, β_{x2}

$$\beta_{x2} = \arcsin \left(\frac{2R_{m2} r_{c0} \sin \beta_{m2} - R_{m2}^2 + R_{x2}^2}{2R_{x2} r_{c0}} \right) \quad (251)$$

Face hobbing and face milling:

Wheel pitch diameter at checkpoint, d_{x2}

$$d_{x2} = 2R_{x2} \sin \delta_2 \quad (252)$$

Normal module at checkpoint, m_{xn}

$$m_{xn} = \frac{d_{x2}}{z_2} \cos \beta_{x2} \quad (253)$$

Intermediate value, z_{nx2}

$$z_{nx2} = \frac{z_2}{\left(1 - \sin^2 \beta_{x2} \cos^2 \alpha_n\right) \cos \beta_{x2} \cos \delta_2} \quad (254)$$

For further calculations, choose the smaller effective pressure angle.

$$\text{If } \alpha_{nC} < \alpha_{nD}: \quad \alpha_{eminx} = \alpha_{nC} \quad (255)$$

$$\text{If } \alpha_{nC} \geq \alpha_{nD}: \quad \alpha_{eminx} = \alpha_{nD} \quad (256)$$

Determination of maximum profile shift coefficient at calculation point, $x_{hm \max x1}$, pinion:

This check is necessary to avoid undercut on the wheel, since $x_{hm2} = -x_{hm1}$

Working tool addendum at checkpoint, k_{hapx}

$$k_{hapx} = k_{hap} + \frac{(R_{x2} - R_{m2}) \tan \theta_{f2}}{m_{mn}} \quad (257)$$

Maximum profile shift coefficient at calculation point, $x_{hm \max x1}$, pinion

$$x_{hm \max x1} = - \left(1,1 k_{hapx} - \frac{z_{nx2} m_{xn} \sin^2 \alpha_{eminx}}{2 m_{mn}} \right) \quad (258)$$

Wheel undercut at checkpoint is avoided, if $x_{hm1} > x_{hm \max x1}$.

Annex A (informative)

Structure of ISO formula set for calculation of geometry data of bevel and hypoid gears

A.1 Purpose

This annex gives the structure of the formulae for the calculation of bevel and hypoid gear geometry in this document. In this structure, the common formulae are put together. However, it is essential that two alternative sets of input data, those used by American Gear Manufacturers Association (AGMA; data type II) and those used in European Standards (data type I), be available to calculate one or more of the four design methods shown.

Unlike bevel gears, a simple determination of the pitch surface parameters is impossible for hypoid gear drives. Therefore, the solution shall be found in a procedure of successive approximation or iteration. Each method needs a set of initial data to start the calculation procedure. However, the pitch cone parameters for bevel gears can also be calculated with different initial data as given in [Table 3](#).

A.2 Structure of the formula set

The structure of the calculation is shown in [Figure A.1](#).

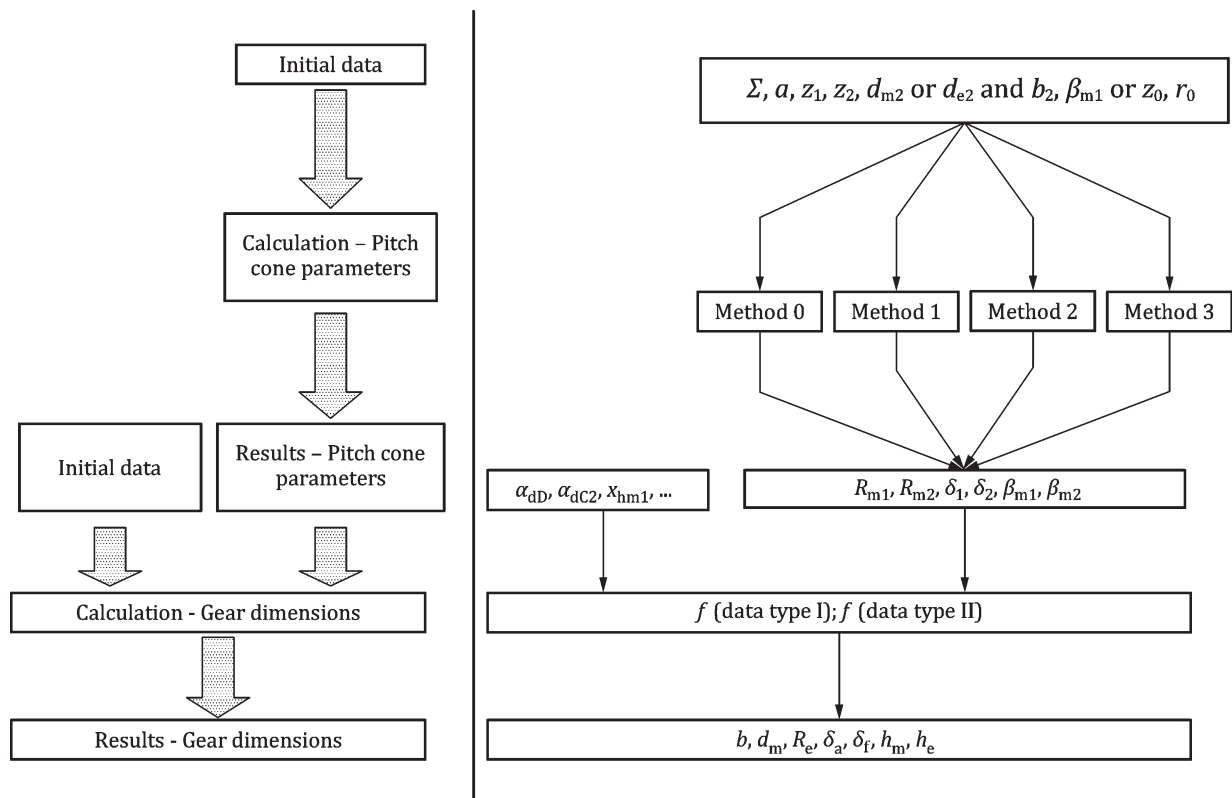

Figure A.1 — Calculation of bevel and hypoid gears

For the calculation of gear geometry, there are two main steps. First, the pitch cone parameters are determined from the initial data using a specific set of formulae for each method. Second, the gear dimensions are determined. Starting from the pitch cone parameters, there is only one set of formulae for bevel and hypoid gears, no matter which method was chosen.

There are commonly two “data types” in use that describe the gear dimensions. Data type I, as used in European Standards, describes, for example, the proportions of the gear teeth with an addendum factor, k_{hap} , a dedendum factor, k_{hfp} , a thickness modification coefficient, x_{smn} , and a profile shift coefficient, x_{hm} . Data type II, as used in the AGMA standards, describes these proportions with a depth factor, k_d , a clearance factor, k_c , a thickness factor, k_t , and a mean addendum factor, c_{ham} . Both means will lead to the same result of tooth geometry: the factors above are related to each other, so that the same gear geometry, derived from data type I, can also be described with data type II. [Annex C](#) gives suggestions for the commonly used values for each data type.

A.3 Pitch cone parameters

As can be seen in [Figure A.1](#), there are currently four different methods for the calculation of the pitch cone parameters. For each method, it shall be ensured that all initial data listed in [Table 2](#) are known. The appropriate formulae lead to the pitch cone parameters, R_{m1} , R_{m2} , δ_1 , δ_2 , β_{m1} , β_{m2} and c_{be2} . With these parameters, a schematic of a hypoid (or bevel) gear can be drawn; see [Figure A.2](#).

Based on the pitch cones, with the additional set of data from [Table 3](#), it is possible to determine the hypoid and bevel gear blank dimensions.

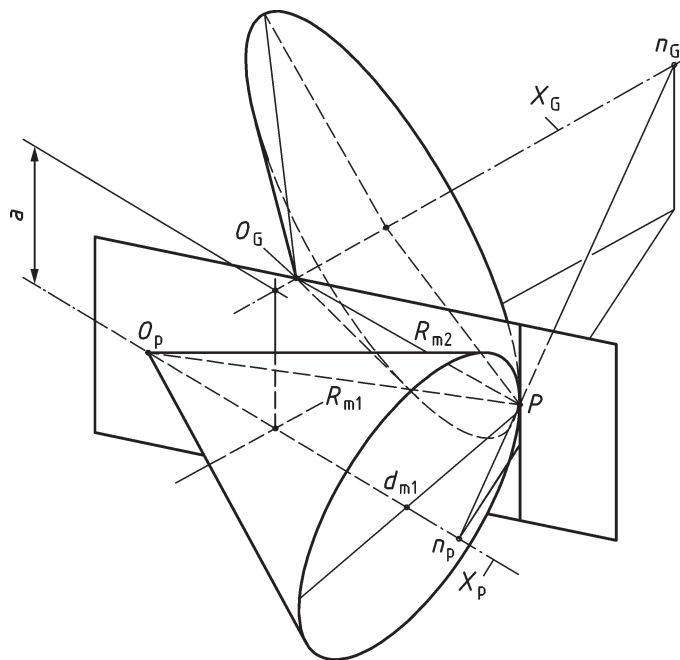

Figure A.2 — Schematic of hypoid gear

The parameter c_{be2} , named “face width factor”, describes the ratio $(R_{e2} - R_{m2})/b_2$. This is because the calculation point is not necessarily in the middle of the wheel face width for method 1. Typically, for methods 2 and 3, where the calculation point is in the middle of the wheel face width, $c_{be2} = 0,5$.

Method 0

This method shall be used for bevel gears without hypoid offset. The formulae can easily be converted, if any initial data are given other than those in [Table 2](#). For these gears, the face width factor is set to $c_{be2} = 0,5$.

Method 1

Method 1 is used by Gleason, the pitch cone parameters have similar values compared with method 3 which is used by Klingelnberg. For method 1, it is necessary to determinate the face width factor, c_{be2} , because the calculation point is not in the middle of the wheel face width.

Method 2

Method 2 is used by Oerlikon.

Method 3

Method 3 is usually used by Klingelnberg.

A.4 Gear dimensions of bevel and hypoid gears

With the data in [Table 3](#), the gear dimensions can be calculated. There is only one set of formulae for bevel and hypoid gears. All formulae for hypoid gears also apply to bevel gears, if the hypoid offset is set to $a = 0$.

Determination of basic data

In [7.2](#), general values, which are partially used in further calculations, are determined. For hypoid gears, the effective pressure angles are established in order to describe the mesh conditions. These become equal if the effective pressure angle, α_{eD} , on the drive side has the same value as the effective pressure angle, α_{eC} , on the coast side. This is the case, for instance, if the design pressure angles are equal and the total limit pressure angle ($f_{\alpha lim} = 1$) is considered in the calculation. However, it is not necessary for a proper hypoid gear set to have equal mesh conditions.

Determination of tooth depth at calculation point

As [Table 4](#) shows how data type II can be transformed into data type I, only one set of formulae is necessary to determine the tooth depth. In this document, it is the formulae for data type I that are given.

Determination of root and face angles

For the determination of the root and face angles of pinion and wheel, the addendum and dedendum angles of the wheel are needed. In this context, the distances, t_{z1} , t_{z2} , t_{zF1} , t_{zF2} , t_{zR1} and t_{zR2} , can be calculated. These are defined as positive, if the crossing point lies inside the respective cone.

Determination of pinion face width

Each method used for the calculation of the pitch cone parameters has its specific formulae to determine the pinion face width. For bevel gears, the pinion face width is equal to the wheel face width. Hypoid gears, calculated with method 2, have the calculation point in the middle of the pinion face width. For this reason, the inner and the outer face width (b_{i1} , b_{e1}) at the pitch cone are equal. However, methods 1 and 3 have different values for b_{i1} and b_{e1} . [Figure A.3](#) illustrates the way to obtain b_{i1} and b_{e1} .

The pinion values, b_{e1} and b_{i1} , represent the real distances from calculation point to inside and outside. To be consistent, b_{e2} and b_{i2} are also established for the wheel. With b_{e1} , b_{i1} , b_{e2} and b_{i2} , it is possible to determine the inner and outer pinion and wheel diameters (d_{ae1} , d_{ae2} , d_{ai1} , d_{ai2}) for all methods with the same formulae.

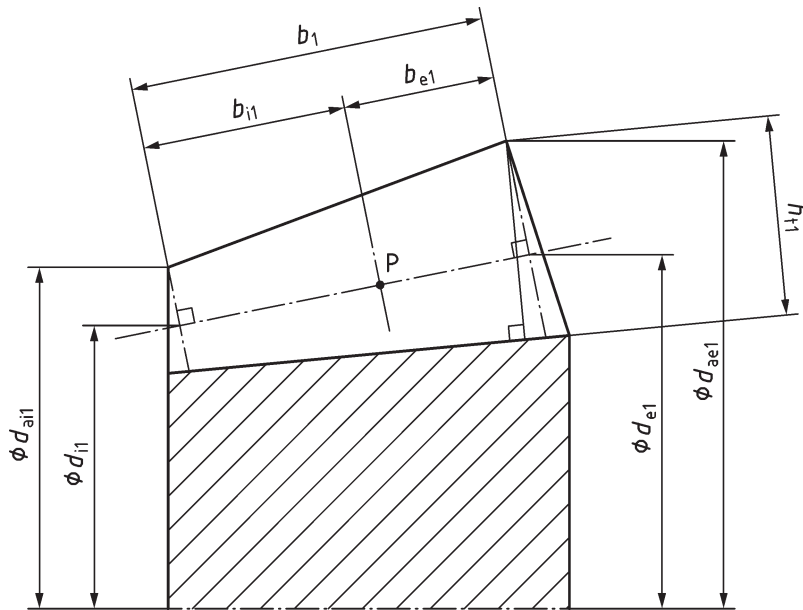

Figure A.3 — Pinion face width and inner and outer diameter

Determination of inner and outer spiral angles

Pinion

The spiral angles of the pinion are calculated at the front crown (R_{i1}) and crown (R_{e1}). To obtain the values of the spiral angles of the pinion, it is first necessary to determine the spiral angles of the wheel at the pertaining boundary point (see Figure A.4). Because of the overlap of the pinion face over the wheel face, the according cone distances of the wheel (R_{e21}/R_{i21}) may be larger/smaller than the outer/inner cone distance. In Figure A.4, these cone distances are illustrated by the dashed line. With the according pinion offset angles, ζ_{ip21} and ζ_{ep21} , at the boundary points, the spiral angles of the pinion can be determined using Formula (187) and Formula (188). A different set of formulae is used for face milling and face hobbing.

Wheel

For the determination of the spiral angles of the wheel at the outer and inner cone distances, there are different formulae for face milling and face hobbing.

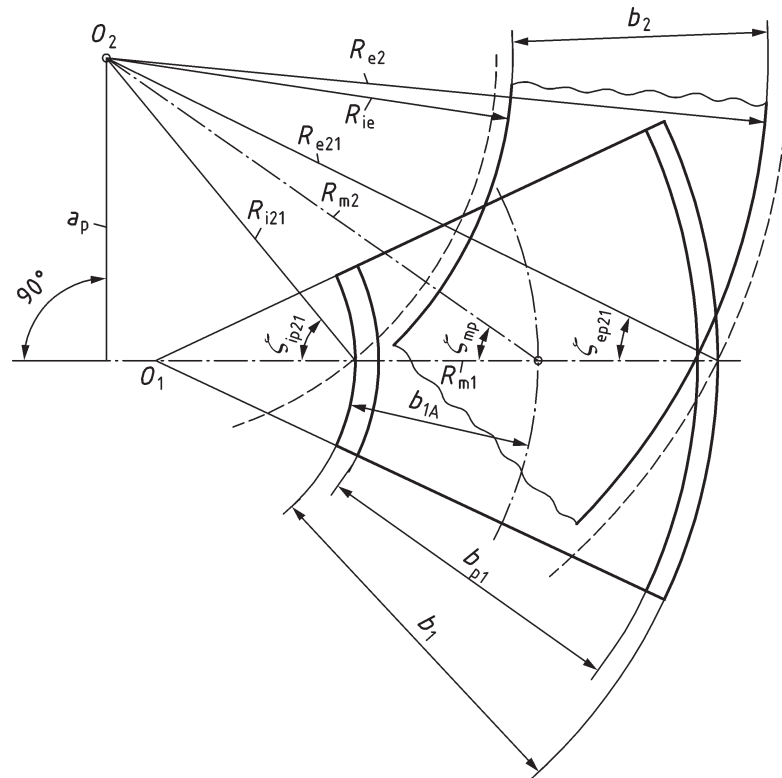

Figure A.4 — Determination of pinion spiral angle in pitch plane

Determination of tooth depth

The definition of the inner and outer tooth depth is illustrated in [Figure A.5](#). The tooth depths h_{ai1} , h_{fi1} , h_{am1} , h_{fm1} , h_{ae1} and h_{fe1} are perpendicular to the pinion pitch cone and h_{t1} is perpendicular to the root cone. The same applies to the wheel tooth depths.

With the implementation of an inner and outer pinion face width at the pitch cone, the inner and outer addendum and dedendum can easily be determined.

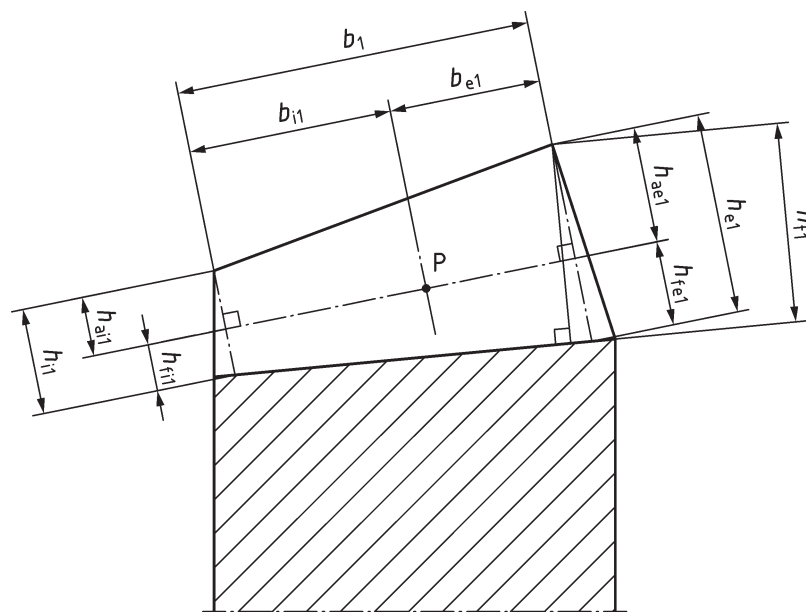

Figure A.5 — Tooth depth at pinion

Determination of tooth thickness

The tooth thickness is calculated from the outer normal backlash, j_{en} , the normal backlash at calculation point, j_n , the transverse backlash at calculation point, j_{t2} , and the outer transverse backlash, j_{et2} .

For data type I, the thickness modification coefficient, x_{smn} , is a theoretical value and does not include the backlash; see [Figure 16](#). To consider the backlash, the modification coefficients x_{sm1} and x_{sm2} are calculated.

In general, for the calculation of the theoretical tooth thickness, the backlash shall be set equal to zero.

Determination of remaining dimensions

[7.9](#) determines the remaining dimensions of bevel and hypoid gears.

A.5 Undercut check

The undercut check is provided for generated gears with non-constant and constant tooth depth. With the set of formulae in [Clause 8](#), it is possible to choose any point on the pinion or wheel face width to check if undercut occurs or not.

The undercut check is based on the concept of a plane-generating gear, the so-called crown gear, which is able to mesh with pinion and wheel at the same time. The cutting process with a crown gear can be described in the following way.

The action of the blades in the cutterhead represents a tooth of the generating gear. The generating gear axis of rotation is identical with the generating cradle axis of the gear cutting machine. The work gear (e.g. the pinion) rolls with the generating gear as with a mating gear, whereby its tooth spaces and flanks are formed. To generate a mating gear which fits properly, a “mirrored” arrangement is used, with the mating gear being cut on the “backside” of the same generating gear. This principle applies independently of the lengthwise tooth form (circular, cycloid or involute).

For different modifications, hyperbolic generating gears, torus-shaped generating gears and helicoidal generating gears are used. For these gears, the undercut formulae are not accurate. Nevertheless, the approximation by a plane-generating gear is a good solution for an estimation of the quantity of undercut.

Annex B (informative)

Pitch cone parameters

B.1 Purpose

The purpose of [Annex B](#) is to give proposals for the values that might be used as initial data for the determination of the pitch cone parameters. If the approach of [Annex B](#) is used, metallurgical considerations should be taken into account.

B.2 Shaft angle

The shaft angle is determined by the application.

B.3 Hypoid offset

In most cases, the hypoid offset is determined by the application. Pinion offset is designated as being positive or negative. This is determined by looking at the hand of spiral of the wheel.

If the pinion offset follows the hand of spiral of the wheel, it is defined as positive. If the pinion offset is opposite to the hand of spiral of the wheel, it is negative.

[Figure B.1](#) illustrates positive and negative pinion offsets as seen from the wheel apex.

It is recommended that positive pinion offset be used because of the increasing diameter of the pinion, higher face contact ratio, pitting and bending load capacity. Special consideration should be given to scuffing resistance because of additional lengthwise sliding.

In general, due to lengthwise sliding, the offset should not exceed 25 % of the wheel outer pitch diameter and, for heavy-duty applications, it should be limited to 12,5 % of the wheel pitch diameter.

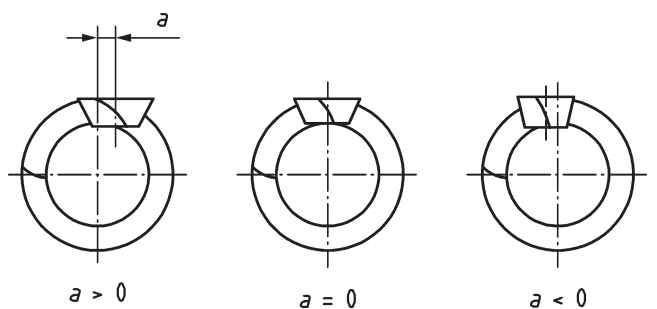

a) Left-hand pinion mated with right-hand wheel

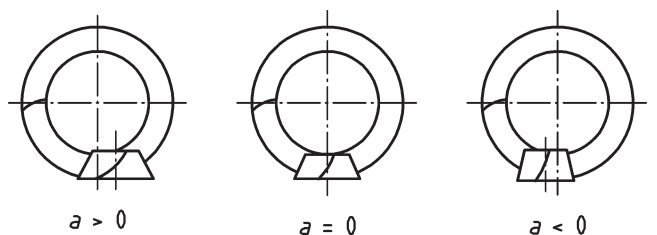

b) Right-hand pinion mated with left-hand wheel

Figure B.1 — Hypoid offset

B.4 Pinion diameter

B.4.1 Estimated load

In most gear applications, the load is not constant. Therefore, the torque load will vary. To obtain values of the operating torque load, the designer should use the value of the power and speed at which the expected operating cycle of the driven apparatus will perform.

In the case where peak loads are present, the total duration of the peak loads is important. If the total duration exceeds 10 million cycles during the total expected life of the gear, use the value of this peak load for estimating the gear size. If the total duration of the peak loads is less than 10 million cycles, start with one half the value of this peak load or the value of the highest sustained load, whichever is greater.

When peak loads are involved, a more detailed analysis is usually required to complete the design.

B.4.2 Torque

Pinion torque is a convenient criterion for approximate rating of bevel gears, requiring conversion from power to torque by the relation:

$$T_1 = \frac{9\,550\,P}{n_1} \tag{B.1}$$

where

T_1 is the pinion torque, in newton metres (N·m) (see [B.4.1](#));

P is the power, in kilowatts (kW);

n_1 is the pinion speed, in revolutions per minute (r/min).

B.4.3 Estimated pinion size

B.4.3.1 General

The charts shown in [Figures B.2](#) and [B.3](#) relate the size of commercial quality spiral bevel pinions to pinion torque. The charts are for 90° shaft angle design. For other than 90° shaft angle designs, the preliminary estimate is less accurate and could require additional adjustments based on the rating calculations.

B.4.3.2 Spiral bevels

For spiral bevel gears of case-hardened steel, the pinion outer pitch diameter is given by [Figures B.2](#) and [B.3](#). Follow vertically from pinion torque value to desired gear ratio, then follow horizontally to pinion outer pitch diameter.

B.4.3.3 Straight and zerol bevels

Straight bevel and zerol bevel gears will be somewhat larger than spiral bevels. The values of pinion outer pitch diameter obtained from [Figures B.2](#) and [B.3](#) are to be multiplied by 1,3 for zerol bevel gears and by 1,2 for straight bevel gears. The larger diameter for the zerol bevel gears is due to a face width limitation.

B.4.3.4 Hypoids

B.4.3.4.1 General

In the hypoid case, the pinion outer pitch diameter, as selected from the chart, is the equivalent pinion outer pitch diameter. A preliminary hypoid pinion pitch diameter, $d_{e\ plm1}$, is given using [Formula \(B.2\)](#):

$$d_{e\ plm1} = d_{e1} - \frac{a}{u} \quad (B.2)$$

where

d_{e1} is pinion outer pitch diameter, from [Figure B.2](#) or [Figure B.3](#), whichever is larger, in millimetres (mm);

a is the hypoid offset, in millimetres (mm);

u is the gear ratio.

The actual wheel outer pitch diameter is determined using [Formulae \(B.3\)](#) to [\(B.6\)](#).

Approximate pinion pitch angle

$$\delta_{int1} = \arctan\left(\frac{\sin\Sigma}{\cos\Sigma + u}\right) \quad (B.3)$$

where

Σ is the shaft angle.

Approximate wheel pitch angle

$$\delta_{\text{int}2} = \Sigma - \delta_{\text{int}1} \quad (\text{B.4})$$

Approximate wheel outer cone distance

$$R_{\text{eint}2} = \frac{d_{\text{eplm}1}}{2\sin\delta_{\text{int}1}} \quad (\text{B.5})$$

Wheel outer pitch diameter

$$d_{\text{e}2} = 2R_{\text{eint}2}\sin\delta_{\text{int}2} \quad (\text{B.6})$$

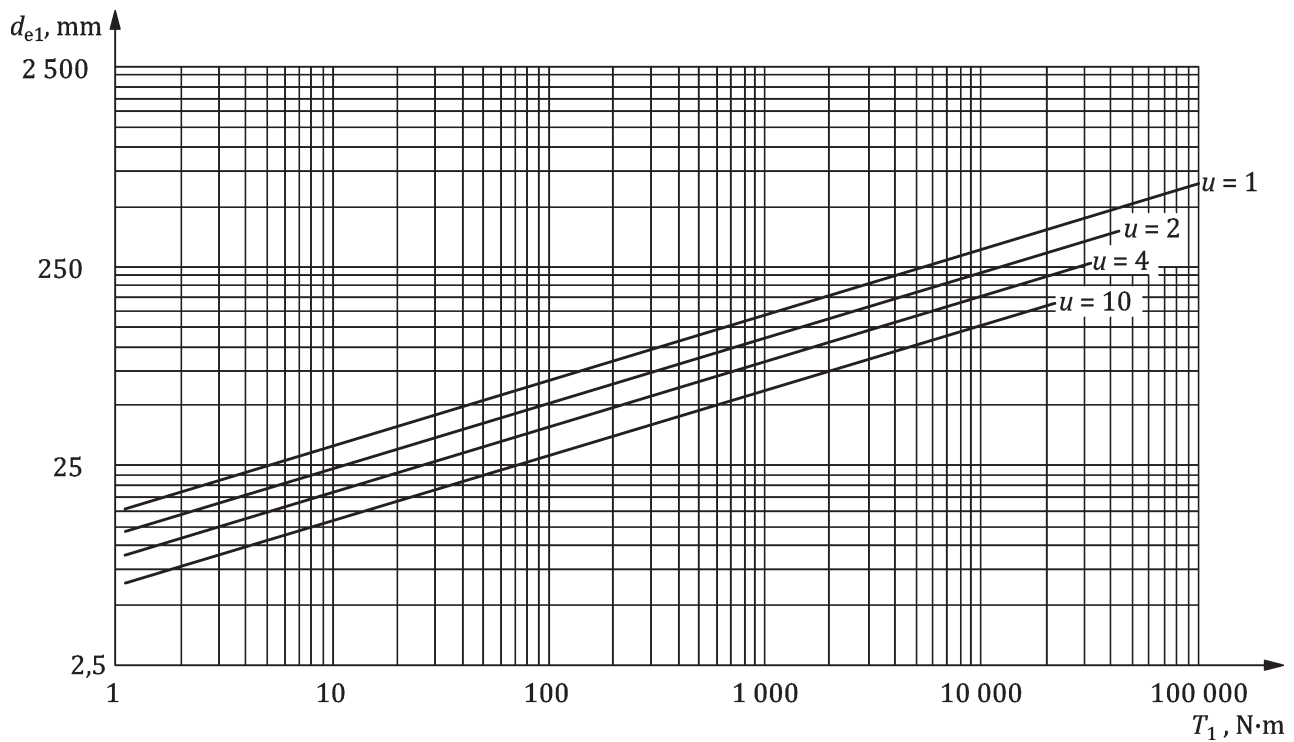

Figure B.2 — Pinion outer pitch diameter versus pinion torque — Pitting resistance

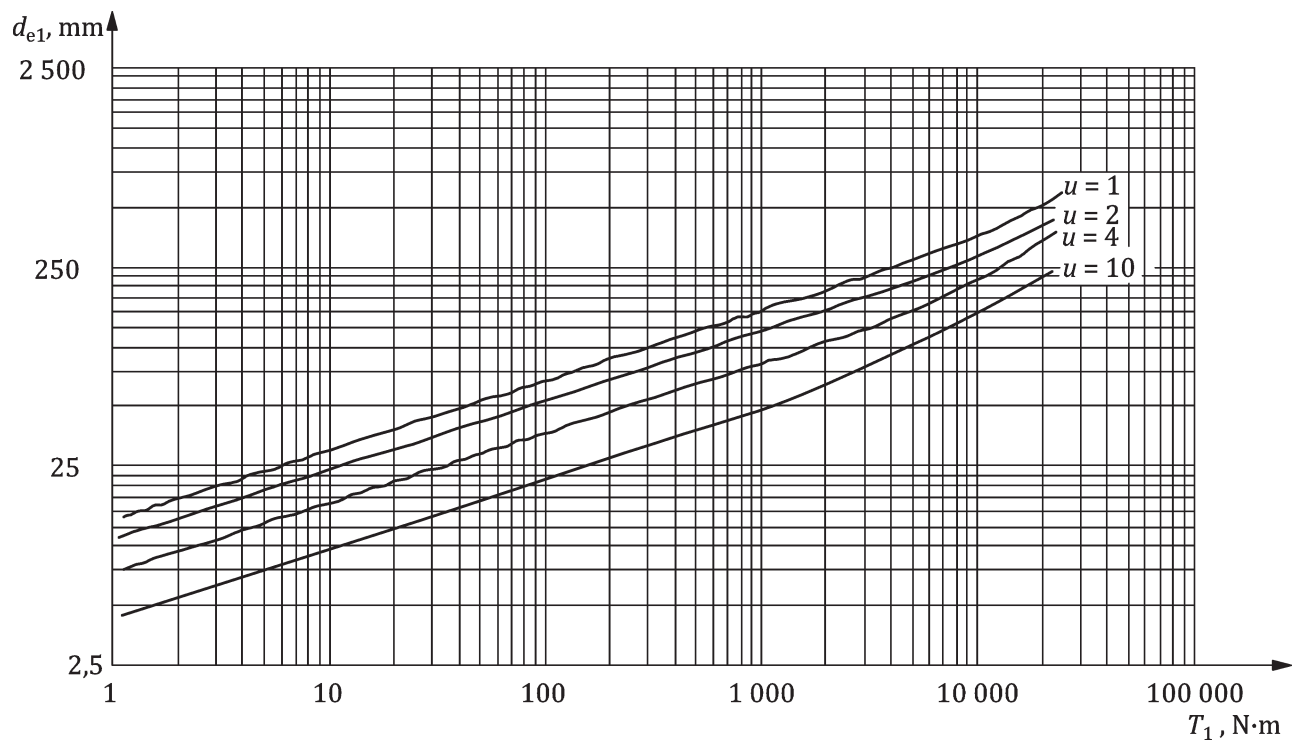

Figure B.3 — Pinion outer pitch diameter versus pinion torque — Bending strength

B.4.3.5 Precision-finished gears

When gears are precision-finished, the load carrying capacity will be increased. The initial pinion size is based on both pitting resistance and bending strength. Based on pitting resistance, the pinion diameter, as given in [Figure B.2](#) or as calculated using [Formula \(B.2\)](#), is to be multiplied by 0,80. Based on bending strength, the pinion outer pitch diameter is given in [Figure B.3](#) or is calculated using [Formula \(B.2\)](#). From these two values, choose the larger diameter.

B.4.3.6 Material factor, K_M

For materials other than case-hardened steel at 55 minimum HRC, the pinion outer pitch diameter, as given in [Figure B.2](#) or as calculated using [Formula \(B.2\)](#), is to be multiplied by the material factor given in [Table B.1](#).

Table B.1 — Material factors

Gear set materials				
Gear material and hardness		Pinion material and hardness		Material factor, K_M
Material	Hardness	Material	Hardness	
Case-hardened steel	58 HRC min	Case-hardened steel	60 HRC min	0,85
Case-hardened steel	55 HRC min	Case-hardened steel	55 HRC min	1,00
Flame-hardened steel	50 HRC min	Case-hardened steel	55 HRC min	1,05
Flame-hardened steel	50 HRC min	Flame-hardened steel	50 HRC min	1,05
Oil-hardened steel	375 HBW to 425 HBW	Oil-hardened steel	375 HBW to 425 HBW	1,20
Heat-treated steel	250 HBW to 300 HBW	Case-hardened steel	55 HRC min	1,45
Heat-treated steel	210 HBW to 245 HBW	Case-hardened steel	55 HRC min	1,45
Cast iron	—	Case-hardened steel	55 HRC min	1,95
Cast iron	—	Flame-hardened steel	50 HRC min	2,00
Cast iron	—	Annealed steel	160 HBW to 200 HBW	2,10
Cast iron	—	Cast iron	—	3,10

NOTE For clarification of all types of heat treatments noted in [Table B.1](#), see ISO 6336-5.

B.4.3.7 Statically loaded gears

Statically loaded gears should be designed for bending strength rather than pitting resistance. For statically loaded gears which are subject to vibration, the pinion outer pitch diameter, as given in [Figure B.3](#) or as calculated using [Formula \(B.2\)](#), is to be multiplied by 0,70. For statically loaded gears which are not subject to vibration, the pinion outer pitch diameter, as given in [Figure B.3](#) or as calculated using [Formula \(B.2\)](#), is to be multiplied by 0,60.

B.5 Numbers of teeth

Although the selection of the numbers of teeth may be made in any arbitrary manner, experience has indicated that for general work, the numbers of teeth selected from [Figures B.4](#) and [B.5](#) will give good results. [Figure B.4](#) is for spiral bevel and hypoid gears and [Figure B.5](#) is for straight bevel and zerol bevel gears. These charts give the suggested number of teeth in the pinion. Hypoid gears which are often used for automotive applications can have fewer numbers of teeth; see [Table B.2](#).

The number of teeth in the mating gear will be determined by the gear ratio. When the gears are to be lapped, the numbers of teeth in the pinion and mating wheel should have no common factor.

Straight bevel gears are designed with 12 teeth and higher. Zerol bevel gears are designed with 13 teeth and higher. This limitation is based on achieving an acceptable contact ratio without undercut.

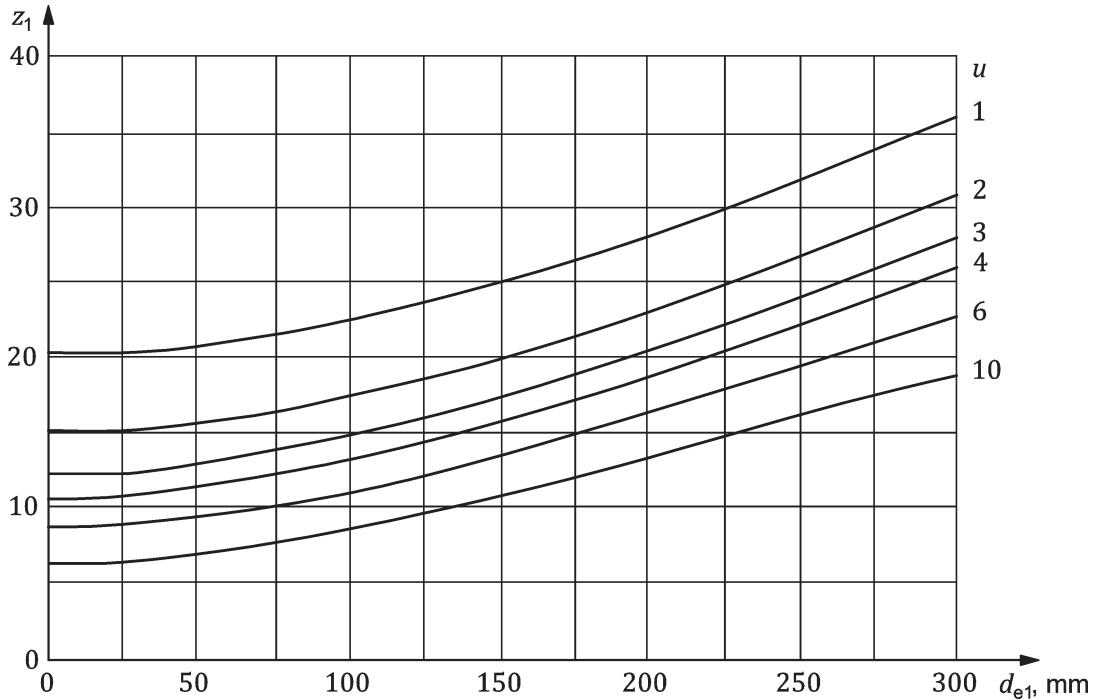

Figure B.4 — Approximate number of pinion teeth for spiral bevel and hypoid gears

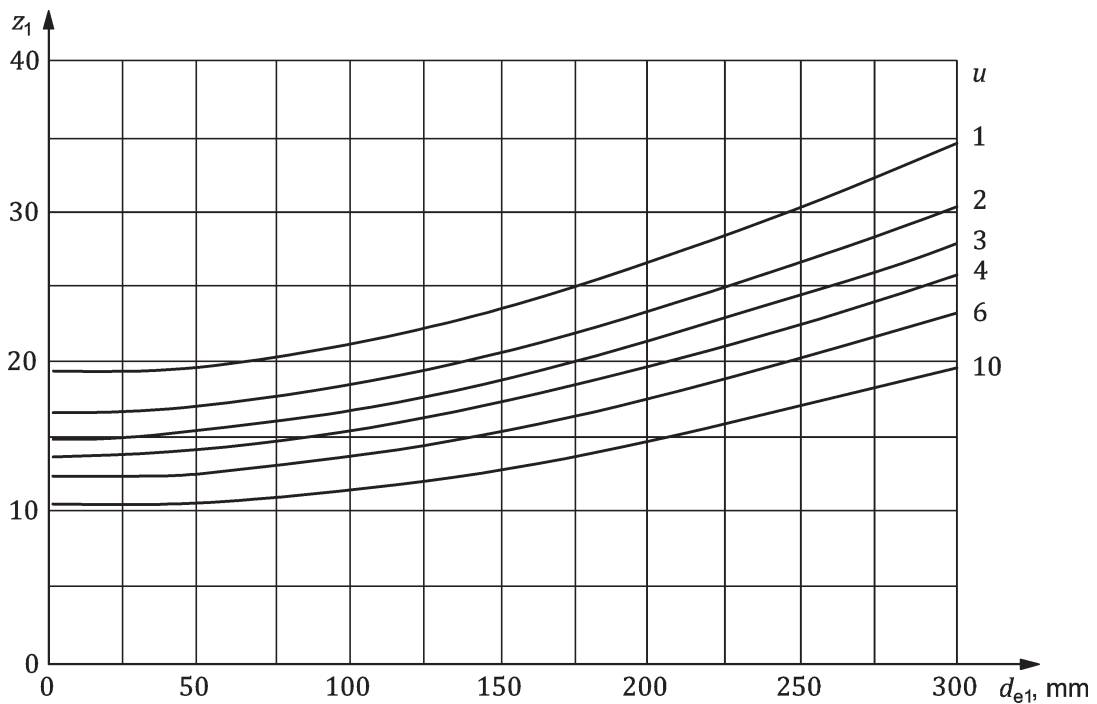

Figure B.5 — Approximate number of pinion teeth for straight bevel and zerol bevel gears

Spiral bevel and hypoid gears can be designed with fewer numbers of teeth because the additional overlap resulting from oblique teeth allows the teeth to be stubbed to avoid undercut and still

maintain an acceptable contact ratio. The three-dimensional effect shall be considered in that the tooth characteristics across the whole face width should be used in the analysis of undercut. In later clauses, recommended pressure angles, tooth depth and addendum proportions will minimize the possibility of undercut. An undercut check should be made to verify that undercut does not exist. [Table B.2](#) gives recommended minimum pinion numbers of teeth for spiral bevel and hypoid gears.

Table B.2 — Suggested minimum numbers of pinion teeth (spiral bevels and hypoids)

Approximate ratio, u	Minimum number of pinion teeth, z_1
$1,00 \leq u \leq 1,50$	13
$1,50 < u \leq 1,75$	12
$1,75 < u \leq 2,00$	11
$2,00 < u \leq 2,50$	10
$2,50 < u \leq 3,00$	9
$3,00 < u \leq 3,50$	9
$3,50 < u \leq 4,00$	9
$4,00 < u \leq 4,50$	8
$4,50 < u \leq 5,00$	7
$5,00 < u \leq 6,00$	6
$6,00 < u \leq 7,50$	5
$7,50 < u \leq 10,0$	5

B.6 Face width

For shaft angles less than 90° , a face width larger than that given in [Figure B.6](#) may be used. For shaft angles greater than 90° , a face width smaller than that given in [Figure B.6](#) should be used. Generally, the face width is 30 % of the cone distance or $10 m_{et2}$, whichever is less. However, design parameters may require values to be larger or smaller. [Figure B.6](#) face widths are based on 30 % of the outer cone distance. For zerol bevel gears, the face width given by [Figure B.6](#) should be multiplied by 0,83 and should not exceed 25 % of the cone distance. For shaft angles substantially less than 90° , care should be exercised to ensure that the ratio of face width to pinion pitch diameter does not become excessive.

In the case of a hypoid, follow the above face width guidelines for the wheel. The hypoid pinion face width is generally greater than the face width of the wheel. Its calculation can be found in [7.5](#).

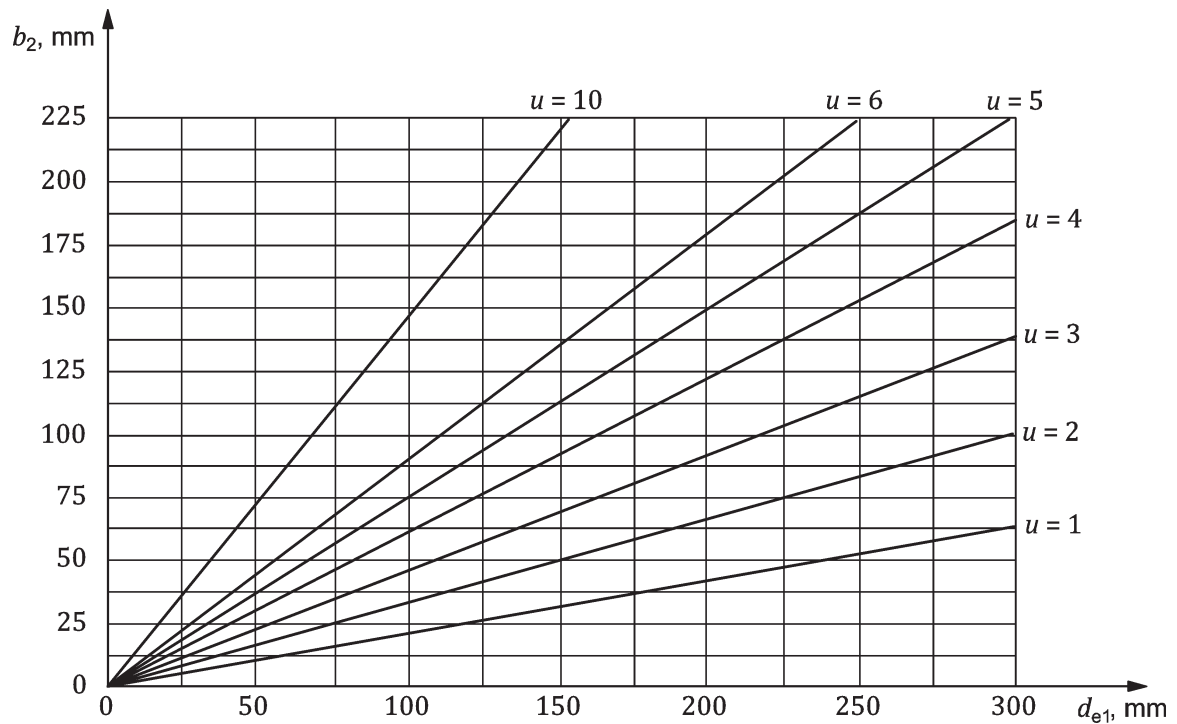

Figure B.6 — Face width of spiral bevel gears operating at 90° shaft angle

B.7 Spiral angle

B.7.1 General

Common design practice suggests that the spiral angle be selected to give a face contact ratio of approximately 2,0. For high-speed applications and maximum smoothness and quietness, face contact ratios greater than 2,0 are suggested, but face contact ratios less than 2,0 are allowed.

B.7.2 Spiral bevels

[Formulae \(B.7\)](#) and [\(B.8\)](#) for face contact ratio, ε_β , may be used to select the spiral angle:

$$K_z = \frac{b}{R_e} \left[\frac{\left(2 - \frac{b}{R_e} \right)}{2 \left(1 - \frac{b}{R_e} \right)} \right] \quad (\text{B.7})$$

$$\varepsilon_\beta = \frac{1}{\pi m_{et}} \left(K_z \tan \beta_m - \frac{K_z^3}{3} \tan^3 \beta_m \right) R_e \quad (\text{B.8})$$

where

R_e is the outer cone distance, in millimetres (mm);

m_{et} is the outer transverse module, in millimetres (mm);

b is the net face width, in millimetres (mm);

β_m is the mean spiral angle at pitch surface.

Figure B.7 may be used to assist in the selection of spiral angle when the face width is 30 % of the outer cone distance.

B.7.3 Hypoids

For hypoid sets, the pinion spiral angle may be calculated using Formula (B.9):

$$\beta_{m1} = 25 + 5 \sqrt{\frac{z_2}{z_1}} + 90 \frac{a}{d_{e2}} \quad (\text{B.9})$$

where

β_{m1} is the pinion mean spiral angle;

z_2 is the number of wheel teeth;

z_1 is the number of pinion teeth;

d_{e2} is the wheel outer pitch diameter, in millimetres (mm).

The wheel spiral angle depends on the hypoid geometry and is calculated using the hypoid formulae in Clause 6.

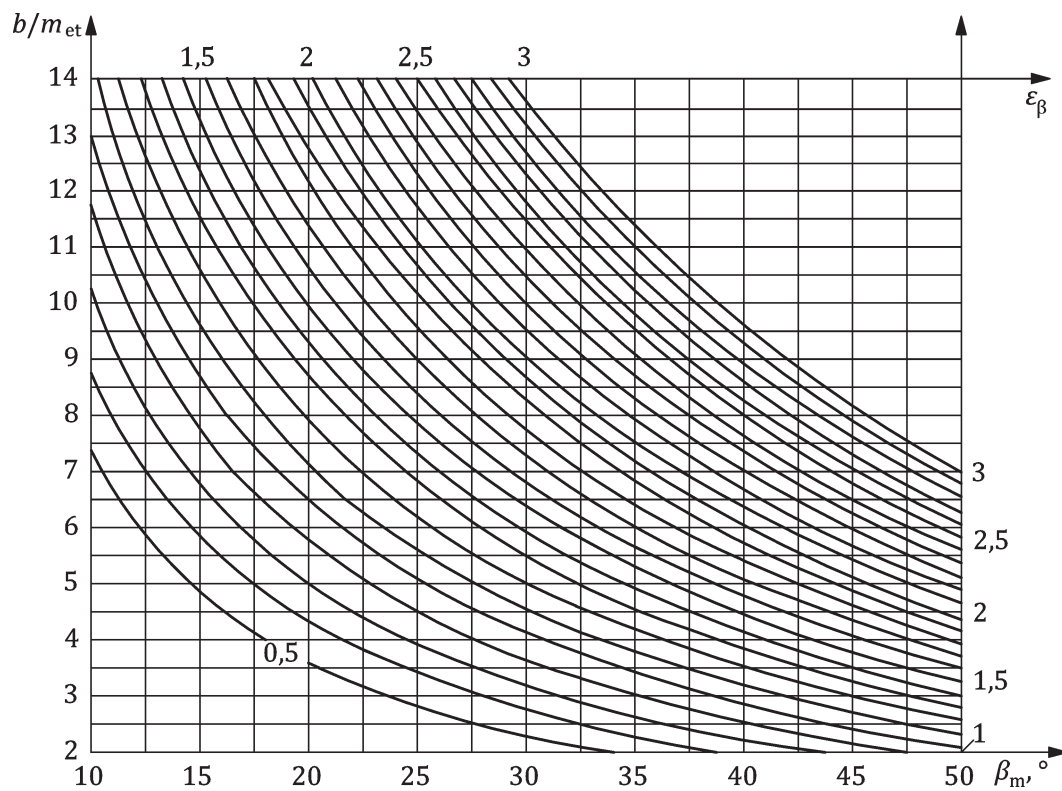

$$\varepsilon_{\beta} = \left(0,388\ 5 \tan\beta_m - 0,017\ 1 \tan^3\beta_m \right) b / m_{et}$$

$$b / R_e = 0,3$$

Figure B.7 — Face contact ratio for spiral bevel gears

B.8 Outer transverse module

The outer transverse module, m_{et2} , is obtained by dividing the outer wheel pitch diameter by the number of teeth in the wheel. Since tooling for bevel gears is not standardized according to module, it is not necessary that the module be an integer.

Annex C (informative)

Gear dimensions

C.1 Purpose

The purpose of [Annex C](#) is to give suggestions for the values of the additional data (see [Clause 7](#)) that are necessary to determine the gear dimensions.

C.2 Normal pressure angle

C.2.1 General

There are three normal pressure angles that are to be considered.

- Nominal design pressure angle, α_d , is the start value for the calculation. It may be half of the sum of pressure angles or different on drive and coast side.
- Generated pressure angle, α_n , is the pressure angle of the generating gear; α_n can be found on the tooth flank in the mean normal section.
- Effective pressure angle, α_e , is a calculated value.

The most commonly used design pressure angle for bevel gears is 20°. This pressure angle affects the gear design in a number of ways. Lower generated pressure angles increase the transverse contact ratio, reduce the axial and separating forces and increase the toplands and slot widths. The converse is true for higher pressure angles. Based on the requirements of the application, the engineer may decide to choose higher or lower design pressure angles. Lower effective pressure angles increase the risk of undercut.

For hypoid gears, it could be reasonable to have unequal generated pressure angles on the coast and drive sides, in order to balance the mesh conditions. If full balance of the mesh conditions is recommended, the influence factor of limit pressure angle, $f_{\alpha_{lim}}$, is set to “1”. Then the limit pressure angle, α_{lim} , is added to the design pressure angle, α_d , on the drive side and subtracted on the coast side in order to obtain the generated normal pressure angle, α_n [see [Formula \(118\)](#) and [Formula \(119\)](#)].

Reducing the generated pressure angles on the drive side may be beneficial for contact ratio, contact stress and axial and radial forces. However, the minimum generated pressure angle should be approximately 9°...10° due to limits of tooling and undercut.

Nevertheless, in all cases, the effective pressure angle, α_e , is calculated according to [Formula \(120\)](#) and [Formula \(121\)](#).

As for bevel (non-hypoid) gears, the limit pressure always is equal to zero, the nominal design pressure angles have the same values as the generated pressure angles. If the effective pressure angles have the same values, the mesh conditions on coast and drive side are equal.

C.2.2 Straight bevels

To avoid undercut, use a nominal design pressure angle of 20° or higher for pinions with 14 teeth to 16 teeth and 25° for pinions with 12 teeth or 13 teeth.

C.2.3 Zerol bevels

On zerol bevels, 22,5° and 25° nominal design pressure angles are used for low tooth numbers, high ratios, or both, to prevent undercut. Use a 22,5° nominal design pressure angle for pinions with 14 teeth to 16 teeth and a 25° nominal design pressure angle for pinions with 13 teeth.

C.2.4 Spiral bevels

To avoid undercut, a 20° design pressure angle or higher for pinions with 12 teeth or fewer teeth may be used.

C.2.5 Hypoids

To balance the mesh conditions on coast and drive side, the influence factor of limit pressure angle should be $f_{\alpha\text{lim}} = 1$. For the use of standard cutting tools, the value of $f_{\alpha\text{lim}}$ may be different from "1". The nominal design pressure angles 18° or 20° may be used for light-duty drives; higher pressure angles such as 22,5° and 25° for heavy-duty drives.

C.3 Tooth depth components

C.3.1 Data type I

NOTE Data types are described in [7.1](#).

C.3.1.1 Addendum factor and dedendum factor

In common cases, the addendum factor, k_{hap} , is set to $k_{\text{hap}} = 1$ and the dedendum factor, k_{hfp} , is set to $k_{\text{hfp}} = 1,25$.

C.3.1.2 Profile shift coefficient

To prevent undercut, the profile shift coefficient shall be in the range given in [Clause 8](#).

C.3.2 Data type II

NOTE Data types are described in [7.1](#).

C.3.2.1 Depth factor

Normally, a depth factor, k_d , of 2,000 is used to calculate mean working depth, h_{mw} , but it can be varied to suit design and other requirements. [Table C.1](#) gives the suggested depth factors based on pinion tooth numbers.

Table C.1 — Suggested depth factor, k_d

Type of gear	Depth factor	Number of pinion teeth
Straight bevel	2,000	12 or more
Spiral bevel	2,000	12 or more
	1,995	11
	1,975	10
	1,940	9
	1,895	8
	1,835	7
	1,765	6
Zerol bevel	2,000	13 or more
Hypoid	2,000	11 or more
	1,950	10
	1,900	9
	1,850	8
	1,800	7
	1,750	6

C.3.2.2 Clearance factor

While the clearance is constant along the entire length of the tooth, the calculation is made at mean point. Normally, the value of 0,125 is used for the clearance factor, k_c , but it can be varied to suit the design and other requirements.

During the manufacturing of fine pitch gearing, $m_{et2} = 1,27$ and finer, 0,051 mm should be added to the clearance of the teeth which are to be finished in a secondary machining operation. This 0,051 mm should not be included in the calculations.

C.3.2.3 Mean addendum factor

This factor apportions the working depth between the pinion and wheel addendums. The pinion addendum is usually longer than the wheel addendum, except when the numbers of teeth are equal. Longer addendums are used on the pinion to avoid undercut. Suggested values for shaft angles $\Sigma = 90^\circ$ for c_{ham} are found in [Table C.2](#). Other values based on sliding velocity, topland or point width limits, or matching strength between two members, can be used. [Clause 8](#) gives the limits for the mean addendum factor to prevent undercut on pinion and wheel. For [Table C.2](#), the equivalent ratio u shall be calculated.

Wheel offset angle in axial plane, η

$$\eta = a \sin(\sin \zeta_m \cos \delta_2) \quad (C.1)$$

Equivalent ratio, u_a

$$u_a = \sqrt{\frac{\cos \delta_1 \tan \delta_2 \cos \eta}{\cos \delta_2}} \quad (C.2)$$

Table C.2 — Mean addendum factor for shaft angles $\Sigma = 90^\circ$, c_{ham}

Type of gear	Mean addendum factor	Number of pinion teeth
Straight bevel	$0,210 + 0,290/u_a^2$	12 or more
Spiral bevel and hypoid	$0,210 + 0,290/u_a^2$	12 or more
	$0,210 + 0,280/u_a^2$	11
	$0,175 + 0,260/u_a^2$	10
	$0,145 + 0,235/u_a^2$	9
	$0,130 + 0,195/u_a^2$	8
	$0,110 + 0,160/u_a^2$	7
	$0,100 + 0,115/u_a^2$	6
Zerol bevel	$0,210 + 0,290/u_a^2$	13 or more

C.4 Tooth thickness components

C.4.1 Data type I

C.4.1.1 Thickness modification coefficient

Values for the thickness modification coefficient, x_{smn} , can be found, regarding the bending strength balance between pinion and wheel. After the thickness modification, a successful cutting process shall be ensured.

C.4.2 Data type II

C.4.2.1 Thickness factor

The mean normal circular thickness is calculated at the mean point. Values of k_t based on balanced bending stress are found by using the graph in [Figure C.1](#). Other values of k_t may be used if a different strength balance is desired.

C.4.2.2 Outer normal backlash

Suggested minimum values of the outer backlash are given in [Table C.3](#). It will be noted that the backlash allowance is proportional to the module. Two ranges of values are given: one for ISO accuracy grades 4 to 7, the other for ISO accuracy grades 8 to 12, according to ISO 1328-1.

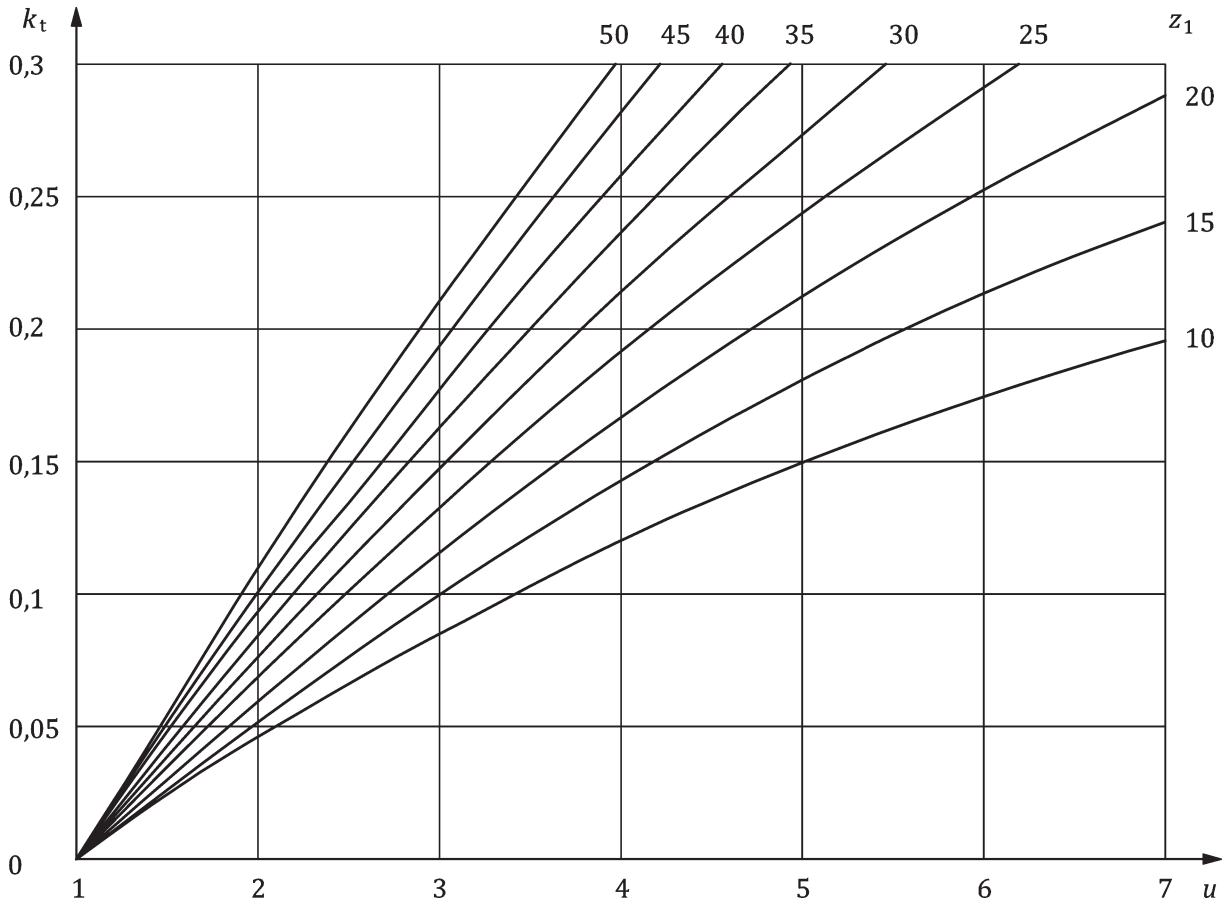

$$k_t = -0,088 + 0,092u - 0,004u^2 + 0,0016(z_1 - 30)(u - 1).$$

Figure C.1 — Thickness factor, k_t

Table C.3 — Typical minimum normal backlash measured at outer cone

Outer transverse module	Minimum normal backlash	
	mm	
	ISO accuracy grades	
	4 to 7	8 to 12
25,00 to 20,00	0,61	0,81
20,00 to 16,00	0,51	0,69
16,00 to 12,00	0,38	0,51
12,00 to 10,00	0,30	0,41
10,00 to 8,00	0,25	0,33
8,00 to 6,00	0,20	0,25
6,00 to 5,00	0,15	0,20
5,00 to 4,00	0,13	0,15
4,00 to 3,00	0,10	0,13
3,00 to 2,50	0,08	0,10
2,50 to 2,00	0,05	0,08
2,00 to 1,50	0,05	0,08
1,50 to 1,25	0,03	0,05
1,25 to 1,00	0,03	0,05

C.5 Addendum angle and dedendum angle of wheel

C.5.1 Sum of dedendum angles, $\Sigma\theta_f$

The sum of the dedendum angles of pinion and wheel is a calculated value that is established by the depthwise taper which is chosen in accordance with the cutting method. The formulae for calculating this value are listed in [Table C.4](#).

Table C.4 — Sum of dedendum angles, $\Sigma\theta_f$

Depthwise taper	Sum of dedendum angles (degrees)
Standard	$\Sigma\theta_{fs} = \arctan\left(\frac{h_{fm1}}{R_{m2}}\right) + \arctan\left(\frac{h_{fm2}}{R_{m2}}\right)$ (C.3)
Uniform depth	$\Sigma\theta_{fu} = 0$
Constant slot width	$\Sigma\theta_{fc} = \left(\frac{90m_{et}}{R_{e2} \tan\alpha_n \cos\beta_m}\right) \left(1 - \frac{R_{m2} \sin\beta_{m2}}{r_{c0}}\right)$ (C.4)
Modified slot width	$\Sigma\theta_{fm} = \Sigma\theta_{fc}$ or $\Sigma\theta_{fm} = 1,3 \Sigma\theta_{fs}$, whichever is smaller (C.5)

C.5.2 Angles, θ_{a2} and θ_{f2}

The sum of the dedendum angles is apportioned between the pinion and the wheel using the formulae in [Table C.5](#). The desired depthwise taper dictates which formulae are to be used when determining the dedendum angles of each member.

Table C.5 — Angles, θ_{a2} and θ_{f2} , wheels

Depthwise taper	Angles (degrees)	
Standard	$\theta_{a2} = \arctan \left(\frac{h_{fm1}}{R_{m2}} \right)$	(C.6)
	$\theta_{f2} = \Sigma \theta_{fS} - \theta_{a2}$	(C.7)
Uniform depth	$\theta_{a2} = \theta_{f2} = 0$	
Constant slot width	$\theta_{a2} = \Sigma \theta_{fC} \frac{h_{am2}}{h_{mw}}$	(C.8)
	$\theta_{f2} = \Sigma \theta_{fC} - \theta_{a2}$	(C.9)
Modified slot width	$\theta_{a2} = \Sigma \theta_{fM} \frac{h_{am2}}{h_{mw}}$	(C.10)
	$\theta_{f2} = \Sigma \theta_{fM} - \theta_{a2}$	(C.11)

Annex D (informative)

Analysis of forces

D.1 Purpose

The purpose of [Annex D](#) is to estimate the forces at the mesh that result from the gear geometry and the transformed torque.

D.2 Analysis of forces

The gear tooth forces result in tangential, axial and radial components, for the purpose of determining the forces and moments which act on shafts and bearings. The axial and radial forces are dependent on the curvature of the loaded tooth flank. Use [Table D.1](#) to determine the loaded flank. The formulae to calculate the forces are presented as follows.

Table D.1 — Loaded flank

Driver hand of spiral	Rotation of driver	Loaded flank	
		Driver	Driven
Right	Clockwise	Convex	Concave
	Anticlockwise (counterclockwise)	Concave	Convex
Left	Clockwise	Concave	Convex
	Anticlockwise (counterclockwise)	Convex	Concave

D.3 Tangential force

The tangential force on a wheel is

$$F_{mt2} = \frac{2\,000 T_2}{d_{m2}} \quad (D.1)$$

where

F_{mt2} is the tangential force at the mean diameter on the wheel, in newtons (N);

T_2 is the torque transmitted by the wheel, in newton metres (N·m).

The tangential force on the mating pinion is given by [Formula \(D.2\)](#):

$$F_{mt1} = \frac{F_{mt2} \cos \beta_{m1}}{\cos \beta_{m2}} = \frac{2\,000 T_1}{d_{m1}} \quad (D.2)$$

where

F_{mt1} is the tangential force at the mean diameter on the pinion, in newtons (N).

D.4 Axial force

The values of axial force, F_{ax} , on bevel gears are given in the following formulae. The symbols in the formulae represent the values (e.g. tangential force, spiral angle, pitch angle, generated pressure angle) for the wheel or pinion member under consideration.

For drive side flank loading

Pinion axial force, $F_{ax1,D}$

$$F_{ax1,D} = \left(\tan\alpha_{nD} \frac{\sin\delta_1}{\cos\beta_{m1}} + \tan\beta_{m1} \cos\delta_1 \right) F_{mt1} \quad (D.3)$$

Wheel axial force, $F_{ax2,D}$

$$F_{ax2,D} = \left(\tan\alpha_{nD} \frac{\sin\delta_2}{\cos\beta_{m2}} - \tan\beta_{m2} \cos\delta_2 \right) F_{mt2} \quad (D.4)$$

For coast side flank loading

Pinion axial force, $F_{ax1,C}$

$$F_{ax1,C} = \left(\tan\alpha_{nC} \frac{\sin\delta_1}{\cos\beta_{m1}} - \tan\beta_{m1} \cos\delta_1 \right) F_{mt1} \quad (D.5)$$

Wheel axial force, $F_{ax2,C}$

$$F_{ax2,C} = \left(\tan\alpha_{nC} \frac{\sin\delta_2}{\cos\beta_{m2}} + \tan\beta_{m2} \cos\delta_2 \right) F_{mt2} \quad (D.6)$$

A positive sign (+) indicates that the direction of thrust is away from pitch apex.

A negative sign (-) indicates that the direction of thrust is towards pitch apex.

D.5 Radial force

The values of radial force, F_{rad} , on bevel gears are given in the following formulae. When using the formulae the tangential force, spiral angle, pitch angle and generated pressure angle of the corresponding member shall be used.

For drive side flank loading

Pinion radial force, $F_{rad1,D}$

$$F_{rad1,D} = \left(\tan\alpha_{nD} \frac{\cos\delta_1}{\cos\beta_{m1}} - \tan\beta_{m1} \sin\delta_1 \right) F_{mt1} \quad (D.7)$$

Wheel radial force, $F_{rad2,D}$

$$F_{rad2,D} = \left(\tan\alpha_{nD} \frac{\cos\delta_2}{\cos\beta_{m2}} + \tan\beta_{m2} \sin\delta_2 \right) F_{mt2} \quad (D.8)$$

For coast side flank loading

Pinion radial force, $F_{\text{rad1,C}}$

$$F_{\text{rad1,C}} = \left(\tan\alpha_{\text{nC}} \frac{\cos\delta_1}{\cos\beta_{\text{m1}}} + \tan\beta_{\text{m1}} \sin\delta_1 \right) F_{\text{mt1}} \quad (\text{D.9})$$

Wheel radial force, $F_{\text{rad2,C}}$

$$F_{\text{rad2,C}} = \left(\tan\alpha_{\text{nC}} \frac{\cos\delta_2}{\cos\beta_{\text{m2}}} - \tan\beta_{\text{m2}} \sin\delta_2 \right) F_{\text{mt2}} \quad (\text{D.10})$$

A positive sign (+) indicates that the direction of force is away from the mating member. This is commonly called the separating force.

A negative sign (–) indicates that the direction of force is towards the mating member. This is commonly called the attracting force.

Annex E (informative)

Machine tool data

E.1 Purpose

[Annex E](#) provides vendor data which influence hypoid gear design.

E.2 Cutter table

Since bevel gear design and manufacture are functions of the cutter radius and, for face hobbed gears, also the number of blade groups, [Table E.1](#) provides a list of standard cutters.

Table E.1 — Nominal cutter radii, r_{c0} , and blade groups, z_0

Face hobbing						Face milling
Two-part cutter (two divided cutter parts for inner and outer blades)		Two-blade cutter (outer and inner blade per group)		Three-blade cutter (rougner, outer and inner blade per group)		Cutter diameter, $2r_{c0}$ in
Cutter radius, r_{c0} mm	Number of blade groups, z_0	Cutter radius, r_{c0} mm	Number of blade groups, z_0	Cutter radius, r_{c0} mm	Number of blade groups, z_0	
25	1	30	7	39	5	2,5
25	2	51	7	49	7	3,25
30	3	64	11	62	5	3,5
40	3	64	13	74	11	3,75
55	5	76	7	88	7	4,375
75	5	76	13	88	13	5
100	5	76	17	110	9	6
135	5	88	11	140	11	7,5
170	5	88	17	150	12	9
210	5	88	19	160	13	10,5
260	5	100	5	181	13	12
270	3	105	13	—	—	14
350	3	105	19	—	—	16
450	3	125	13	—	—	18
—	—	150	17	—	—	—
—	—	175	19	—	—	—
—	—	—	—	—	—	mm
—	—	—	—	—	—	500
—	—	—	—	—	—	640
—	—	—	—	—	—	800
—	—	—	—	—	—	1 000

Annex F (informative)

Sample calculations

F.1 Purpose

[Annex F](#) demonstrates in four examples how to handle the formula set for bevel and hypoid gears.

F.2 Sample spiral bevel gear set

F.2.1 Initial data

This example uses Method 0 — Face milling tooth form.

See [Tables F.1](#) to [F.3](#).

Table F.1 — Initial data for calculation of pitch cone parameters

Symbol	Description	Method 0	Method 1	Method 2	Method 3
Σ	shaft angle	90°	X	X	X
a	hypoid offset	0 mm	X	X	X
$z_{1,2}$	number of teeth	14/39	X	X	X
d_{m2}	mean pitch diameter of wheel	—	—	X	—
d_{e2}	outer pitch diameter of wheel	176,893 mm	X	—	X
b_2	wheel face width	25,4 mm	X	X	X
β_{m1}	mean spiral angle of pinion	—	X	—	—
β_{m2}	mean spiral angle of wheel	35°	—	X	X
r_{c0}	cutter radius	114,3 mm	X	X	X
z_0	number of blade groups (only face hobbing)	—	—	X	X

Table F.2 — Additional data for calculation of gear dimensions

Data type I		Data type II	
Symbol	Description	Symbol	Description
α_{dD}		20°	
α_{dC}		20°	
f_{alim}		0	
x_{hm1}	—	C_{ham}	0,247 37
k_{hap}	—	k_d	2,000
k_{hfp}	—	k_c	0,125
x_{smn}	—	k_t	0,091 5
		W_{m2}	—
j_{en}		0,127	
θ_{a2}		2,134 2°	
θ_{f2}		6,493 4°	

Table F.3 — Transformation of data type II into data type I

$x_{hm1} = k_d \left(\frac{1}{2} - c_{ham} \right) = 0,505$
$k_{hap} = \frac{k_d}{2} = 1$
$k_{hfp} = k_d \left(k_c + \frac{1}{2} \right) = 1,25$
$x_{smn} = \frac{k_t}{2} = 0,046$

F.2.2 Determination of pitch cone parameters

Gear ratio, u

$$u = \frac{z_2}{z_1} = 2,786 \quad (\text{F.1})$$

Pinion pitch angle, δ_1

$$\delta_1 = \arctan\left(\frac{\sin\Sigma}{\cos\Sigma + u}\right) = 19,747^\circ \quad (\text{F.2})$$

Wheel pitch angle, δ_2

$$\delta_2 = \Sigma - \delta_1 = 70,253^\circ \quad (\text{F.3})$$

Outer cone distance, R_e

$$R_{e1,2} = \frac{d_{e2}}{2\sin\delta_2} = 93,973 \text{ mm} \quad (\text{F.4})$$

Mean cone distance, R_m

$$R_{m1,2} = R_{e2} - \frac{b_2}{2} = 81,273 \text{ mm} \quad (\text{F.5})$$

Spiral angle, β_{m1} , pinion

$$\beta_{m1} = \beta_{m2} = 35,000^\circ \quad (\text{F.6})$$

Face width factor, c_{be2}

$$c_{be2} = 0,5$$

F.2.3 Determination of basic data

Pinion mean pitch diameter, d_{m1}

$$d_{m1} = 2R_{m1}\sin\delta_1 = 54,918 \text{ mm} \quad (\text{F.7})$$

Wheel mean pitch diameter, d_{m2}

$$d_{m2} = 2R_{m2}\sin\delta_2 = 152,987 \text{ mm} \quad (\text{F.8})$$

Shaft angle departure from 90° , $\Delta\Sigma$

$$\Delta\Sigma = \Sigma - 90^\circ = 0^\circ \quad (\text{F.9})$$

Offset angle in the pinion axial plane, ζ_m

$$\zeta_m = \arcsin \left(\frac{2a}{d_{m2} + d_{m1} \frac{\cos \delta_2}{\cos \delta_1}} \right) = 0,000^\circ \quad (\text{F.10})$$

Offset angle in the pitch plane, ζ_{mp}

$$\zeta_{mp} = \arcsin \left(\frac{\sin \zeta_m \sin \Sigma}{\cos \delta_1} \right) = 0,000^\circ \quad (\text{F.11})$$

Offset in pitch plane, a_p

$$a_p = R_{m2} \sin \zeta_{mp} = 0,000 \text{ mm} \quad (\text{F.12})$$

Mean normal module, m_{mn}

$$m_{mn} = \frac{2R_{m2} \sin \delta_2 \cos \beta_{m2}}{z_2} = 3,213 \text{ mm} \quad (\text{F.13})$$

Limit pressure angle, α_{lim}

$$\alpha_{lim} = -\arctan \left[\frac{\tan \delta_1 \tan \delta_2 \left(\frac{R_{m1} \sin \beta_{m1} - R_{m2} \sin \beta_{m2}}{R_{m1} \tan \delta_1 + R_{m2} \tan \delta_2} \right)}{\cos \zeta_{mp}} \right] = 0^\circ \quad (\text{F.14})$$

Generated normal pressure angle, α_{nD} , drive side

$$\alpha_{nD} = \alpha_{dD} + f_{\alpha_{lim}} \alpha_{lim} = 20^\circ \quad (\text{F.15})$$

Generated normal pressure angle, α_{nC} , coast side

$$\alpha_{nC} = \alpha_{dC} - f_{\alpha_{lim}} \alpha_{lim} = 20^\circ \quad (\text{F.16})$$

Effective pressure angle, α_{eD} , drive side

$$\alpha_{eD} = \alpha_{nD} - \alpha_{lim} = 20^\circ \quad (\text{F.17})$$

Effective pressure angle, α_{eC} , coast side

$$\alpha_{eC} = \alpha_{nC} + \alpha_{lim} = 20^\circ \quad (\text{F.18})$$

Outer pitch cone distance, R_{e2} , wheel

$$R_{e2} = R_{m2} + c_{be2} b_2 = 93,973 \text{ mm} \quad (\text{F.19})$$

Inner pitch cone distance, R_{i2} , wheel

$$R_{i2} = R_{e2} - b_2 = 68,573 \text{ mm} \quad (\text{F.20})$$

Outer pitch diameter, d_{e2} , wheel

$$d_{e2} = 2R_{e2} \sin \delta_2 = 176,893 \text{ mm} \quad (\text{F.21})$$

Inner pitch diameter, d_{i2} , wheel

$$d_{i2} = 2R_{i2} \sin \delta_2 = 129,080 \text{ mm} \quad (\text{F.22})$$

Outer transverse module, m_{et2}

$$m_{et2} = \frac{d_{e2}}{z_2} = 4,536 \text{ mm} \quad (\text{F.23})$$

Wheel face width from calculation point to outside, b_{e2}

$$b_{e2} = R_{e2} - R_{m2} = 12,700 \text{ mm} \quad (\text{F.24})$$

Wheel face width from calculation point to inside, b_{i2}

$$b_{i2} = R_{m2} - R_{i2} = 12,700 \text{ mm} \quad (\text{F.25})$$

Crossing point to calculation point along wheel axis, t_{zm2}

$$t_{zm2} = \frac{d_{m1} \sin \delta_2}{2 \cos \delta_1} - 0,5 \cos \zeta_m \tan \Delta \Sigma \left(d_{m2} + \frac{d_{m1} \cos \delta_2}{\cos \delta_1} \right) = 27,459 \text{ mm} \quad (\text{F.26})$$

Crossing point to calculation point along pinion axis, t_{zm1}

$$t_{zm1} = \frac{d_{m2}}{2} \cos \zeta_m \cos \Delta \Sigma - t_{zm2} \sin \Delta \Sigma = 76,493 \text{ mm} \quad (\text{F.27})$$

Pitch apex beyond crossing point along axis, $t_{z1,2}$

$$t_{z1} = R_{m1} \cos \delta_1 - t_{zm1} = 0 \text{ mm} \quad (\text{F.28})$$

$$t_{z2} = R_{m2} \cos \delta_2 - t_{zm2} = 0 \text{ mm} \quad (\text{F.29})$$

F.2.4 Determination of tooth depth at calculation point

Mean working depth, h_{mw}

$$h_{mw} = 2m_{mn} k_{hap} = 6,427 \text{ mm} \quad (\text{F.30})$$

Mean addendum, h_{am2} , wheel

$$h_{am2} = m_{mn} (k_{hap} - x_{hm1}) = 1,591 \text{ mm} \quad (\text{F.31})$$

Mean dedendum, h_{fm2} , wheel

$$h_{fm2} = m_{mn} (k_{hfp} + x_{hm1}) = 5,639 \text{ mm} \quad (\text{F.32})$$

Mean addendum, h_{am1} , pinion

$$h_{am1} = m_{mn} (k_{hap} + x_{hm1}) = 4,836 \text{ mm} \quad (\text{F.33})$$

Mean dedendum, h_{fm1} , pinion

$$h_{fm1} = m_{mn} (k_{hfp} - x_{hm1}) = 2,394 \text{ mm} \quad (\text{F.34})$$

Clearance, c

$$c = m_{mn} (k_{hfp} - k_{hap}) = 0,803 \text{ mm} \quad (\text{F.35})$$

Mean whole depth, h_m

$$h_m = h_{am1,2} + h_{fm1,2} = 7,230 \text{ mm} \quad (\text{F.36})$$

$$h_m = m_{mn} (k_{hap} + k_{hfp}) = 7,230 \text{ mm} \quad (\text{F.37})$$

F.2.5 Determination of root angles and face angles

Face angle, δ_{a2} , wheel

$$\delta_{a2} = \delta_2 + \theta_{a2} = 72,387^\circ \quad (\text{F.38})$$

Root angle, δ_{f2} , wheel

$$\delta_{f2} = \delta_2 - \theta_{f2} = 63,760^\circ \quad (\text{F.39})$$

Auxiliary angle for calculating pinion offset angle in root plane, φ_R

$$\varphi_R = \arctan \left(\frac{a \tan \Delta \Sigma \cos \delta_{f2}}{R_{m2} \cos \theta_{f2} - t_{z2} \cos \delta_{f2}} \right) = 0^\circ \quad (\text{F.40})$$

Auxiliary angle for calculating pinion offset angle in face plane, φ_o

$$\varphi_o = \arctan \left(\frac{a \tan \Delta \Sigma \cos \delta_{a2}}{R_{m2} \cos \theta_{a2} - t_{z2} \cos \delta_{a2}} \right) = 0^\circ \quad (\text{F.41})$$

Pinion offset angle in root plane, ζ_R

$$\zeta_R = \arcsin \left(\frac{a \cos \varphi_R \sin \delta_{f2}}{R_{m2} \cos \theta_{f2} - t_{z2} \cos \delta_{f2}} \right) - \varphi_R = 0^\circ \quad (\text{F.42})$$

Pinion offset angle in face plane, ζ_o

$$\zeta_o = \arcsin \left(\frac{a \cos \varphi_o \sin \delta_{a2}}{R_{m2} \cos \theta_{a2} - t_{z2} \cos \delta_{a2}} \right) - \varphi_o = 0^\circ \quad (\text{F.43})$$

Face angle, δ_{a1} , pinion

$$\delta_{a1} = \arcsin(\sin\Delta\Sigma \sin\delta_{f2} + \cos\Delta\Sigma \cos\delta_{f2} \cos\zeta_R) = 26,240^\circ \quad (\text{F.44})$$

Root angle, δ_{f1} , pinion

$$\delta_{f1} = \arcsin(\sin\Delta\Sigma \sin\delta_{a2} + \cos\Delta\Sigma \cos\delta_{a2} \cos\zeta_o) = 17,613^\circ \quad (\text{F.45})$$

Addendum angle, θ_{a1} , pinion

$$\theta_{a1} = \delta_{a1} - \delta_1 = 6,493^\circ \quad (\text{F.46})$$

Dedendum angle, θ_{f1} , pinion

$$\theta_{f1} = \delta_1 - \delta_{f1} = 2,134^\circ \quad (\text{F.47})$$

Wheel face apex beyond crossing point along wheel axis, t_{zF2}

$$t_{zF2} = t_{z2} - \frac{R_{m2} \sin\theta_{a2} - h_{am2} \cos\theta_{a2}}{\sin\delta_{a2}} = -1,508 \text{ mm} \quad (\text{F.48})$$

Wheel root apex beyond crossing point along wheel axis, t_{zR2}

$$t_{zR2} = t_{z2} + \frac{R_{m2} \sin\theta_{f2} - h_{fm2} \cos\theta_{f2}}{\sin\delta_{f2}} = 3,999 \text{ mm} \quad (\text{F.49})$$

Pinion face apex beyond crossing point along pinion axis, t_{zF1}

$$t_{zF1} = \frac{a \sin\zeta_R \cos\delta_{f2} - t_{zR2} \sin\delta_{f2} - c}{\sin\delta_{a1}} = -9,931 \text{ mm} \quad (\text{F.50})$$

Pinion root apex beyond crossing point along pinion axis, t_{zR1}

$$t_{zR1} = \frac{a \sin\zeta_o \cos\delta_{a2} - t_{zF2} \sin\delta_{a2} - c}{\sin\delta_{f1}} = 2,094 \text{ mm} \quad (\text{F.51})$$

F.2.6 Determination of pinion face width, b_1

Pinion face width in pitch plane, b_{p1}

$$b_{p1} = \sqrt{R_{e2}^2 - a_p^2} - \sqrt{R_{i2}^2 - a_p^2} = 25,400 \text{ mm} \quad (\text{F.52})$$

Pinion face width from calculation point to front crown, b_{1A}

$$b_{1A} = \sqrt{R_{m2}^2 - a_p^2} - \sqrt{R_{i2}^2 - a_p^2} = 12,700 \text{ mm} \quad (\text{F.53})$$

Method 0:

Pinion face width, b_1

$$b_1 = b_2 = 25,400 \text{ mm} \quad (\text{F.54})$$

Pinion face width from calculation point to outside, b_{e1}

$$b_{e1} = c_{be2} b_1 = 12,700 \text{ mm} \quad (\text{F.55})$$

Pinion face width from calculation point to inside, b_{i1}

$$b_{i1} = b_1 - b_{e1} = 12,700 \text{ mm} \quad (\text{F.56})$$

F.2.7 Determination of inner and outer spiral angles

F.2.7.1 Pinion

Wheel cone distance of outer pinion boundary point, R_{e21} (may be larger than R_{e2})

$$R_{e21} = \sqrt{R_{m2}^2 + b_{e1}^2 + 2R_{m2} b_{e1} \cos\zeta_{mp}} = 93,973 \text{ mm} \quad (\text{F.57})$$

Wheel cone distance of inner pinion boundary point, R_{i21} (may be smaller than R_{i2})

$$R_{i21} = \sqrt{R_{m2}^2 + b_{i1}^2 - 2R_{m2} b_{i1} \cos\zeta_{mp}} = 68,573 \text{ mm} \quad (\text{F.58})$$

Face milling:

Wheel spiral angle at outer boundary point, β_{e21}

$$\beta_{e21} = \arcsin\left(\frac{2R_{m2} r_{c0} \sin\beta_{m2} - R_{m2}^2 + R_{e21}^2}{2R_{e21} r_{c0}}\right) = 36,846^\circ \quad (\text{F.59})$$

Wheel spiral angle at inner boundary point, β_{i21}

$$\beta_{i21} = \arcsin\left(\frac{2R_{m2} r_{c0} \sin\beta_{m2} - R_{m2}^2 + R_{i21}^2}{2R_{i21} r_{c0}}\right) = 33,946^\circ \quad (\text{F.60})$$

Face hobbing and face milling:

Pinion offset angle in pitch plane at outer boundary point, ζ_{ep21}

$$\zeta_{ep21} = \arcsin\left(\frac{a_p}{R_{e21}}\right) = 0^\circ \quad (\text{F.61})$$

Pinion offset angle in pitch plane at inner boundary point, ζ_{ip21}

$$\zeta_{ip21} = \arcsin\left(\frac{a_p}{R_{i21}}\right) = 0^\circ \quad (\text{F.62})$$

Outer pinion spiral angle, β_{e1}

$$\beta_{e1} = \beta_{e21} + \zeta_{ep21} = 36,846^\circ \quad (\text{F.63})$$

Inner pinion spiral angle, β_{i1}

$$\beta_{i1} = \beta_{i21} + \zeta_{ip21} = 33,946^\circ \quad (\text{F.64})$$

F.2.7.2 Wheel

Face milling:

Outer wheel spiral angle, β_{e2}

$$\beta_{e2} = \arcsin \left(\frac{2R_{m2} r_{c0} \sin \beta_{m2} - R_{m2}^2 + R_{e2}^2}{2R_{e2} r_{c0}} \right) = 36,846^\circ \quad (\text{F.65})$$

Inner wheel spiral angle, β_{i2}

$$\beta_{i2} = \arcsin \left(\frac{2R_{m2} r_{c0} \sin \beta_{m2} - R_{m2}^2 + R_{i2}^2}{2R_{i2} r_{c0}} \right) = 33,946^\circ \quad (\text{F.66})$$

F.2.8 Determination of tooth depth

Outer addendum, h_{ae}

$$h_{ae1} = h_{am1} + b_{e1} \tan \theta_{a1} = 6,281 \text{ mm} \quad (\text{F.67})$$

$$h_{ae2} = h_{am2} + b_{e2} \tan \theta_{a2} = 2,064 \text{ mm} \quad (\text{F.68})$$

Outer dedendum, h_{fe}

$$h_{fe1} = h_{fm1} + b_{e1} \tan \theta_{f1} = 2,867 \text{ mm} \quad (\text{F.69})$$

$$h_{fe2} = h_{fm2} + b_{e2} \tan \theta_{f2} = 7,085 \text{ mm} \quad (\text{F.70})$$

Outer whole depth, h_e

$$h_{e1} = h_{ae1} + h_{fe1} = 9,149 \text{ mm} \quad (\text{F.71})$$

$$h_{e2} = h_{ae2} + h_{fe2} = 9,149 \text{ mm} \quad (\text{F.72})$$

Inner addendum, h_{ai}

$$h_{ai1} = h_{am1} - b_{i1} \tan \theta_{a1} = 3,391 \text{ mm} \quad (\text{F.73})$$

$$h_{ai2} = h_{am2} - b_{i2} \tan \theta_{a2} = 1,117 \text{ mm} \quad (\text{F.74})$$

Inner dedendum, h_{fi}

$$h_{fi1} = h_{fm1} - b_{i1} \tan \theta_{f1} = 1,921 \text{ mm} \quad (\text{F.75})$$

$$h_{fi2} = h_{fm2} - b_{i2} \tan \theta_{f2} = 4,194 \text{ mm} \quad (\text{F.76})$$

Inner whole depth, h_i

$$h_{i1} = h_{ai1} + h_{fi1} = 5,311 \text{ mm} \quad (\text{F.77})$$

$$h_{i2} = h_{ai2} + h_{fi2} = 5,311 \text{ mm} \quad (\text{F.78})$$

F.2.9 Determination of tooth thickness

Mean normal pressure angle, α_n

$$\alpha_n = \frac{\alpha_{nD} + \alpha_{nC}}{2} = 20^\circ \quad (\text{F.79})$$

Thickness modification coefficient, x_{sm1} , pinion

with outer normal backlash, j_{en}

$$x_{sm1} = x_{smn} - j_{en} \frac{1}{4m_{mn} \cos \alpha_n} \frac{R_{m2} \cos \beta_{m2}}{R_{e2} \cos \beta_{e2}} = 0,037 \quad (\text{F.80})$$

Mean normal circular tooth thickness, s_{mn1} , pinion

$$s_{mn1} = 0,5m_{mn} \pi + 2m_{mn} (x_{sm1} + x_{hm1} \tan \alpha_n) = 6,465 \text{ mm} \quad (\text{F.81})$$

Thickness modification coefficient, x_{sm2} , wheel

with outer normal backlash, j_{en}

$$x_{sm2} = -x_{smn} - j_{en} \frac{1}{4m_{mn} \cos \alpha_n} \frac{R_{m2} \cos \beta_{m2}}{R_{e2} \cos \beta_{e2}} = -0,055 \quad (\text{F.82})$$

Mean normal circular tooth thickness, s_{mn2} , wheel

$$s_{mn2} = 0,5m_{mn} \pi + 2m_{mn} (x_{sm2} - x_{hm1} \tan \alpha_n) = 3,511 \text{ mm} \quad (\text{F.83})$$

Mean transverse circular thickness, s_{mt}

$$s_{mt1} = s_{mn1} / \cos \beta_{m1} = 7,892 \text{ mm} \quad (\text{F.84})$$

$$s_{mt2} = s_{mn2} / \cos \beta_{m2} = 4,286 \text{ mm} \quad (\text{F.85})$$

Mean normal diameter, d_{mn}

$$d_{mn1} = \frac{d_{m1}}{(1 - \sin^2 \beta_{m1} \cos^2 \alpha_n) \cos \delta_1} = 82,241 \text{ mm} \quad (\text{F.86})$$

$$d_{mn2} = \frac{d_{m2}}{\left(1 - \sin^2 \beta_{m2} \cos^2 \alpha_n\right) \cos \delta_2} = 638,207 \text{ mm} \quad (\text{F.87})$$

Mean normal chordal tooth thickness, s_{mnc}

$$s_{mnc1} = d_{mn1} \sin \left(s_{mn1} / d_{mn1} \right) = 6,458 \text{ mm} \quad (\text{F.88})$$

$$s_{mnc2} = d_{mn2} \sin \left(s_{mn2} / d_{mn2} \right) = 3,511 \text{ mm} \quad (\text{F.89})$$

Mean chordal addendum, h_{amc}

$$h_{amc1} = h_{am1} + 0,5d_{mn1} \cos \delta_1 \left[1 - \cos \left(\frac{s_{mn1}}{d_{mn1}} \right) \right] = 4,955 \text{ mm} \quad (\text{F.90})$$

$$h_{amc2} = h_{am2} + 0,5d_{mn2} \cos \delta_2 \left[1 - \cos \left(\frac{s_{mn2}}{d_{mn2}} \right) \right] = 1,592 \text{ mm} \quad (\text{F.91})$$

F.2.10 Determination of remaining gear dimensions

Outer pitch cone distance, R_{e1} , pinion

$$R_{e1} = R_{m1} + b_{e1} = 93,973 \text{ mm} \quad (\text{F.92})$$

Inner pitch cone distance, R_{i1} , pinion

$$R_{i1} = R_{m1} - b_{i1} = 68,573 \text{ mm} \quad (\text{F.93})$$

Outer pitch diameter, d_{e1} , pinion

$$d_{e1} = 2R_{e1} \sin \delta_1 = 63,500 \text{ mm} \quad (\text{F.94})$$

Inner pitch diameter, d_{i1} , pinion

$$d_{i1} = 2R_{i1} \sin \delta_1 = 46,337 \text{ mm} \quad (\text{F.95})$$

Outside diameter, d_{ae}

$$d_{ae1} = d_{e1} + 2h_{ae1} \cos \delta_1 = 75,324 \text{ mm} \quad (\text{F.96})$$

$$d_{ae2} = d_{e2} + 2h_{ae2} \cos \delta_2 = 178,288 \text{ mm} \quad (\text{F.97})$$

Diameter, d_{fe}

$$d_{fe1} = d_{e1} - 2h_{fe1} \cos \delta_1 = 58,102 \text{ mm} \quad (\text{F.98})$$

$$d_{fe2} = d_{e2} - 2h_{fe2} \cos \delta_2 = 172,106 \text{ mm} \quad (\text{F.99})$$

Diameter, d_{ai}

$$d_{ai1} = d_{i1} + 2h_{ai1} \cos \delta_1 = 52,719 \text{ mm} \quad (\text{F.100})$$

$$d_{ai2} = d_{i2} + 2h_{ai2} \cos \delta_2 = 129,835 \text{ mm} \quad (\text{F.101})$$

Diameter, d_{fi}

$$d_{fi1} = d_{i1} - 2h_{fi1} \cos \delta_1 = 42,721 \text{ mm} \quad (\text{F.102})$$

$$d_{fi2} = d_{i2} - 2h_{fi2} \cos \delta_2 = 126,246 \text{ mm} \quad (\text{F.103})$$

Crossing point to crown along axis, $t_{xo1,2}$

$$t_{xo1} = t_{zm1} + b_{e1} \cos \delta_1 - h_{ae1} \sin \delta_1 = 86,324 \text{ mm} \quad (\text{F.104})$$

$$t_{xo2} = t_{zm2} + b_{e2} \cos \delta_2 - h_{ae2} \sin \delta_2 = 29,808 \text{ mm} \quad (\text{F.105})$$

Crossing point to front crown along axis, $t_{xi1,2}$

$$t_{xi1} = t_{zm1} - b_{i1} \cos \delta_1 - h_{ai1} \sin \delta_1 = 63,395 \text{ mm} \quad (\text{F.106})$$

$$t_{xi2} = t_{zm2} - b_{i2} \cos \delta_2 - h_{ai2} \sin \delta_2 = 22,117 \text{ mm} \quad (\text{F.107})$$

Pinion whole depth, h_{t1} , perpendicular to the root cone

$$h_{t1} = \frac{t_{zF1} + t_{xo1}}{\cos \delta_{a1}} \sin(\theta_{a1} + \theta_{f1}) - (t_{zR1} - t_{zF1}) \sin \delta_{f1} = 9,137 \text{ mm} \quad (\text{F.108})$$

F.3 Sample hypoid gear set — Method 1

F.3.1 Initial data

This example uses Method 1 — Face milling tooth form.

See [Tables F.4](#) to [F.6](#).

Table F.4 — Initial data for calculation of pitch cone parameters

Symbol	Description	Method 0	Method 1	Method 2	Method 3
Σ	shaft angle	X	90°	X	X
a	hypoid offset	0,0	15 mm	X	X
$z_{1,2}$	number of teeth	X	13/42	X	X
d_{m2}	mean pitch diameter of wheel	—	—	X	—
d_{e2}	outer pitch diameter of wheel	X	170 mm	—	X
b_2	wheel face width	X	30 mm	X	X
β_{m1}	mean spiral angle of pinion	—	50°	—	—

Table F.4 (continued)

Symbol	Description	Method 0	Method 1	Method 2	Method 3
β_{m2}	mean spiral angle of wheel	X	—	X	X
r_{c0}	cutter radius	X	63,5 mm	X	X
z_0	number of blade groups (only face hobbing)	X	—	X	X

Table F.5 — Additional data for calculation of gear dimensions

Data type I		Data type II	
Symbol	Description	Symbol	Description
α_{dD}		20°	
α_{dC}		20°	
f_{dim}		1	
x_{hm1}	—	c_{ham}	0,35
k_{hap}	—	k_d	2,000
k_{hfp}	—	k_c	0,125
x_{smn}	—	k_t	0,1
		W_{m2}	—
j_{et2}		0,2 mm	
θ_{a2}		1°	
θ_{f2}		4°	

Table F.6 — Transformation of data type II into data type I

$x_{hm1} = k_d \left(\frac{1}{2} - c_{ham} \right) = 0,3$
$k_{hap} = \frac{k_d}{2} = 1$
$k_{hfp} = k_d \left(k_c + \frac{1}{2} \right) = 1,25$
$x_{smn} = \frac{k_t}{2} = 0,05$

F.3.2 Determination of pitch cone parameters

Gear ratio, u

$$u = \frac{z_2}{z_1} = 3,231 \quad (\text{F.109})$$

Desired pinion spiral angle, $\beta_{\Delta 1}$, pinion

$$\beta_{\Delta 1} = \beta_{m1} = 50^\circ \quad (\text{F.110})$$

Shaft angle departure from 90° , $\Delta\Sigma$

$$\Delta\Sigma = \Sigma - 90^\circ = 0^\circ \quad (\text{F.111})$$

Approximate wheel pitch angle, $\delta_{\text{int}2}$

$$\delta_{\text{int}2} = \arctan \left[\frac{u \cos \Delta\Sigma}{1,2(1 - u \sin \Delta\Sigma)} \right] = 69,624^\circ \quad (\text{F.112})$$

Wheel mean pitch radius, $r_{\text{mpt}2}$

$$r_{\text{mpt}2} = \frac{d_{e2} - b_2 \sin \delta_{\text{int}2}}{2} = 70,939 \text{ mm} \quad (\text{F.113})$$

Approximate pinion offset angle in pitch plane, ε'_i

$$\varepsilon'_i = \arcsin \left(\frac{a \sin \delta_{\text{int}2}}{r_{\text{mpt}2}} \right) = 11,433^\circ \quad (\text{F.114})$$

Approximate hypoid dimension factor, K_1

$$K_1 = \tan \beta_{\Delta 1} \sin \varepsilon'_i + \cos \varepsilon'_i = 1,216 \quad (\text{F.115})$$

Approximate pinion mean radius, $r_{\text{mn}1}$

$$r_{\text{mn}1} = \frac{r_{\text{mpt}2} K_1}{u} = 26,708 \text{ mm} \quad (\text{F.116})$$

Start of iteration

***** **First trial** *****

Wheel offset angle in axial plane, η

$$\eta = \arctan \left[\frac{a}{r_{\text{mpt}2} (\tan \delta_{\text{int}2} \cos \Delta\Sigma - \sin \Delta\Sigma) + r_{\text{mn}1}} \right] = 3,942^\circ \quad (\text{F.117})$$

Intermediate pinion offset angle in axial plane, ε_2

$$\varepsilon_2 = \arcsin \left(\frac{a - r_{\text{mn}1} \sin \eta}{r_{\text{mpt}2}} \right) = 10,694^\circ \quad (\text{F.118})$$

Intermediate pinion pitch angle, δ_{int1}

$$\delta_{\text{int1}} = \arctan \left(\frac{\sin \eta}{\tan \varepsilon_2 \cos \Delta \Sigma} + \tan \Delta \Sigma \cos \eta \right) = 20,001^\circ \quad (\text{F.119})$$

Intermediate pinion offset angle in pitch plane, ε'_2

$$\varepsilon'_2 = \arcsin \left(\frac{\sin \varepsilon_2 \cos \Delta \Sigma}{\cos \delta_{\text{int1}}} \right) = 11,390^\circ \quad (\text{F.120})$$

Intermediate pinion mean spiral angle, $\beta_{\text{m int1}}$

$$\beta_{\text{m int1}} = \arctan \left(\frac{K_1 - \cos \varepsilon'_2}{\sin \varepsilon'_2} \right) = 50,087^\circ \quad (\text{F.121})$$

Increment in hypoid dimension factor, ΔK

$$\Delta K = \sin \varepsilon'_2 \left(\tan \beta_{\Delta 1} - \tan \beta_{\text{m int1}} \right) = -7,309 \times 10^{-4} \quad (\text{F.122})$$

Pinion mean radius increment, Δr_{mpt1}

$$\Delta r_{\text{mpt1}} = r_{\text{mpt2}} \frac{\Delta K}{u} = -1,605 \times 10^{-2} \text{ mm} \quad (\text{F.123})$$

Pinion offset angle in axial plane, ε_1

$$\varepsilon_1 = \arcsin \left(\sin \varepsilon_2 - \frac{\Delta r_{\text{mpt1}}}{r_{\text{mpt2}}} \sin \eta \right) = 10,695^\circ \quad (\text{F.124})$$

Pinion pitch angle, δ_1

$$\delta_1 = \arctan \left(\frac{\sin \eta}{\tan \varepsilon_1 \cos \Delta \Sigma} + \tan \Delta \Sigma \cos \eta \right) = 20,000^\circ \quad (\text{F.125})$$

Pinion offset angle in pitch plane, ε'_1

$$\varepsilon'_1 = \arcsin \left(\frac{\sin \varepsilon_1 \cos \Delta \Sigma}{\cos \delta_1} \right) = 11,391^\circ \quad (\text{F.126})$$

Spiral angle, β_{m1} , pinion

$$\beta_{\text{m1}} = \arctan \left(\frac{K_1 + \Delta K - \cos \varepsilon'_1}{\sin \varepsilon'_1} \right) = 49,998^\circ \quad (\text{F.127})$$

Spiral angle, β_{m2} , wheel

$$\beta_{\text{m2}} = \beta_{\text{m1}} - \varepsilon'_1 = 38,608^\circ \quad (\text{F.128})$$

Wheel pitch angle, δ_2

$$\delta_2 = \arctan \left(\frac{\sin \varepsilon_1}{\tan \eta \cos \Delta \Sigma} + \cos \varepsilon_1 \tan \Delta \Sigma \right) = 69,631^\circ \quad (\text{F.129})$$

Mean cone distance, R_{m1} , pinion

$$R_{m1} = \frac{r_{mn1} + \Delta r_{mpt1}}{\sin \delta_1} = 78,045 \text{ mm} \quad (\text{F.130})$$

Mean cone distance, R_{m2} , wheel

$$R_{m2} = \frac{r_{mpt2}}{\sin \delta_2} = 75,670 \text{ mm} \quad (\text{F.131})$$

Mean pinion radius, r_{mpt1}

$$r_{mpt1} = R_{m1} \sin \delta_1 = 26,692 \text{ mm} \quad (\text{F.132})$$

Limit pressure angle, α_{lim}

$$\alpha_{lim} = \arctan \left[-\frac{\tan \delta_1 \tan \delta_2}{\cos \varepsilon'_1} \left(\frac{R_{m1} \sin \beta_{m1} - R_{m2} \sin \beta_{m2}}{R_{m1} \tan \delta_1 + R_{m2} \tan \delta_2} \right) \right] = -3,098^\circ \quad (\text{F.133})$$

Limit radius of curvature, ρ_{lim}

$$\rho_{lim} = \frac{\sec \alpha_{lim} (\tan \beta_{m1} - \tan \beta_{m2})}{-\tan \alpha_{lim} \left(\frac{\tan \beta_{m1}}{R_{m1} \tan \delta_1} + \frac{\tan \beta_{m2}}{R_{m2} \tan \delta_2} \right) + \frac{1}{R_{m1} \cos \beta_{m1}} - \frac{1}{R_{m2} \cos \beta_{m2}}} = 71,539 \text{ mm} \quad (\text{F.134})$$

Face milling:

Lengthwise tooth mean radius of curvature $\rho_{m\beta}$

$$\rho_{m\beta} = r_{c0} = 63,5 \text{ mm} \quad (\text{F.135})$$

$$\left| \frac{\rho_{m\beta}}{\rho_{lim}} - 1 \right| = 0,112 > 0,01 \text{ failed, next trial}$$

***** Last Trial *****

Wheel offset angle in axial plane, η

$$\eta = 4,183^\circ \quad (\text{F.136})$$

Intermediate pinion offset angle in axial plane, ε_2

$$\varepsilon_2 = \arcsin \left(\frac{a - r_{mn1} \sin \eta}{r_{mpt2}} \right) = 10,602^\circ \quad (\text{F.137})$$

Intermediate pinion pitch angle, δ_{int1}

$$\delta_{\text{int1}} = \arctan\left(\frac{\sin\eta}{\tan\varepsilon_2 \cos\Delta\Sigma} + \tan\Delta\Sigma \cos\eta\right) = 21,290^\circ \quad (\text{F.138})$$

Intermediate pinion offset angle in pitch plane, ε'_2

$$\varepsilon'_2 = \arcsin\left(\frac{\sin\varepsilon_2 \cos\Delta\Sigma}{\cos\delta_{\text{int1}}}\right) = 11,389^\circ \quad (\text{F.139})$$

Intermediate pinion mean spiral angle, $\beta_{\text{m int1}}$

$$\beta_{\text{m int1}} = \arctan\left(\frac{K_1 - \cos\varepsilon'_2}{\sin\varepsilon'_2}\right) = 50,089^\circ \quad (\text{F.140})$$

Increment in hypoid dimension factor, ΔK

$$\Delta K = \sin\varepsilon'_2 \left(\tan\beta_{\Delta 1} - \tan\beta_{\text{m int1}}\right) = -7,477 \times 10^{-4} \quad (\text{F.141})$$

Pinion mean radius increment, Δr_{mpt1}

$$\Delta r_{\text{mpt1}} = r_{\text{mpt2}} \frac{\Delta K}{u} = -1,642 \times 10^{-2} \text{ mm} \quad (\text{F.142})$$

Pinion offset angle in axial plane, ε_1

$$\varepsilon_1 = \arcsin\left(\sin\varepsilon_2 - \frac{\Delta r_{\text{mpt1}}}{r_{\text{mpt2}}} \sin\eta\right) = 10,603^\circ \quad (\text{F.143})$$

Pinion pitch angle, δ_1

$$\delta_1 = \arctan\left(\frac{\sin\eta}{\tan\varepsilon_1 \cos\Delta\Sigma} + \tan\Delta\Sigma \cos\eta\right) = 21,288^\circ \quad (\text{F.144})$$

Pinion offset angle in pitch plane, ε'_1

$$\varepsilon'_1 = \arcsin\left(\frac{\sin\varepsilon_1 \cos\Delta\Sigma}{\cos\delta_1}\right) = 11,390^\circ \quad (\text{F.145})$$

Spiral angle, β_{m1} , pinion

$$\beta_{\text{m1}} = \arctan\left(\frac{K_1 + \Delta K - \cos\varepsilon'_1}{\sin\varepsilon'_1}\right) = 49,998^\circ \quad (\text{F.146})$$

Spiral angle, β_{m2} , wheel

$$\beta_{\text{m2}} = \beta_{\text{m1}} - \varepsilon'_1 = 38,609^\circ \quad (\text{F.147})$$

Wheel pitch angle, δ_2

$$\delta_2 = \arctan\left(\frac{\sin\varepsilon_1}{\tan\eta \cos\Delta\Sigma} + \cos\varepsilon_1 \tan\Delta\Sigma\right) = 68,323^\circ \quad (\text{F.148})$$

Mean cone distance, R_{m1} , pinion

$$R_{m1} = \frac{r_{mn1} + \Delta r_{mpt1}}{\sin \delta_1} = 73,519 \text{ mm} \quad (\text{F.149})$$

Mean cone distance, R_{m2} , wheel

$$R_{m2} = \frac{r_{mpt2}}{\sin \delta_2} = 76,337 \text{ mm} \quad (\text{F.150})$$

Mean pinion radius, r_{mpt1}

$$r_{mpt1} = R_{m1} \sin \delta_1 = 26,692 \text{ mm} \quad (\text{F.151})$$

Limit pressure angle, α_{lim}

$$\alpha_{lim} = \arctan \left[-\frac{\tan \delta_1 \tan \delta_2}{\cos \varepsilon'_1} \left(\frac{R_{m1} \sin \beta_{m1} - R_{m2} \sin \beta_{m2}}{R_{m1} \tan \delta_1 + R_{m2} \tan \delta_2} \right) \right] = -2,253^\circ \quad (\text{F.152})$$

Number of crown gear teeth, z_p

$$z_p = \frac{z_2}{\sin \delta_2} = 45,196 \quad (\text{F.153})$$

Lead angle of cutter, ν

$$\nu = \arcsin \left(\frac{R_{m2} z_0}{r_{c0} z_p} \cos \beta_{m2} \right) = 0^\circ \quad (\text{F.154})$$

First auxiliary angle, λ

$$\lambda = 90^\circ - \beta_{m2} + \nu = 51,391^\circ \quad (\text{F.155})$$

Crown gear to cutter centre distance, ρ_{p0}

$$\rho_{p0} = \sqrt{R_{m2}^2 + r_{c0}^2 - 2R_{m2} r_{c0} \cos \lambda} = 61,726 \text{ mm} \quad (\text{F.156})$$

Second auxiliary angle, η_1

$$\eta_1 = \arccos \left[\frac{R_{m2} \cos \beta_{m2}}{\rho_{p0} z_p} (z_p + z_0) \right] = 14,895^\circ \quad (\text{F.157})$$

Lengthwise tooth mean radius of curvature, $\rho_{m\beta}$

Face milling:

$$\rho_{m\beta} = r_{c0} = 63,5 \text{ mm} \quad (\text{F.158})$$

Limit radius of curvature, ρ_{lim}

$$\rho_{\text{lim}} = \frac{\sec\alpha_{\text{lim}} (\tan\beta_{\text{m1}} - \tan\beta_{\text{m2}})}{-\tan\alpha_{\text{lim}} \left(\frac{\tan\beta_{\text{m1}}}{R_{\text{m1}} \tan\delta_1} + \frac{\tan\beta_{\text{m2}}}{R_{\text{m2}} \tan\delta_2} \right) + \frac{1}{R_{\text{m1}} \cos\beta_{\text{m1}}} - \frac{1}{R_{\text{m2}} \cos\beta_{\text{m2}}}} = 63,497 \text{ mm} \quad (\text{F.159})$$

$$\left| \frac{\rho_{\text{m}\beta}}{\rho_{\text{lim}}} - 1 \right| = 4,836 \times 10^{-5} < 0,01, \text{ passed}$$

$$c_{\text{be2}} = \frac{\frac{d_{\text{e2}}}{2 \sin \delta_2} - R_{\text{m2}}}{b_2} = 0,504 \quad (\text{F.160})$$

End of iteration

F.3.3 Determination of basic data

Pinion mean pitch diameter, d_{m1}

$$d_{\text{m1}} = 2R_{\text{m1}} \sin\delta_1 = 53,383 \text{ mm} \quad (\text{F.161})$$

Wheel mean pitch diameter, d_{m2}

$$d_{\text{m2}} = 2R_{\text{m2}} \sin\delta_2 = 141,877 \text{ mm} \quad (\text{F.162})$$

Shaft angle departure from 90° , $\Delta\Sigma$

$$\Delta\Sigma = \Sigma - 90^\circ = 0^\circ \quad (\text{F.163})$$

Offset angle in the pinion axial plane, ζ_{m}

$$\zeta_{\text{m}} = \arcsin \left(\frac{2a}{d_{\text{m2}} + d_{\text{m1}} \frac{\cos\delta_2}{\cos\delta_1}} \right) = 10,603^\circ \quad (\text{F.164})$$

Offset angle in the pitch plane, ζ_{mp}

$$\zeta_{\text{mp}} = \arcsin \left(\frac{\sin\zeta_{\text{m}} \sin\Sigma}{\cos\delta_1} \right) = 11,390^\circ \quad (\text{F.165})$$

Offset in pitch plane, a_{p}

$$a_{\text{p}} = R_{\text{m2}} \sin\zeta_{\text{mp}} = 15,075 \text{ mm} \quad (\text{F.166})$$

Mean normal module, m_{mn}

$$m_{mn} = \frac{2R_{m2} \sin \delta_2 \cos \beta_{m2}}{z_2} = 2,640 \text{ mm} \quad (\text{F.167})$$

Limit pressure angle, α_{lim}

$$\alpha_{lim} = -\arctan \left[\frac{\tan \delta_1 \tan \delta_2 \left(\frac{R_{m1} \sin \beta_{m1} - R_{m2} \sin \beta_{m2}}{R_{m1} \tan \delta_1 + R_{m2} \tan \delta_2} \right)}{\cos \zeta_{mp}} \right] = -2,253^\circ \quad (\text{F.168})$$

Generated normal pressure angle, α_{nD} , drive side

$$\alpha_{nD} = \alpha_{dD} + f_{\alpha_{lim}} \alpha_{lim} = 17,747^\circ \quad (\text{F.169})$$

Generated normal pressure angle, α_{nC} , coast side

$$\alpha_{nC} = \alpha_{dC} - f_{\alpha_{lim}} \alpha_{lim} = 22,253^\circ \quad (\text{F.170})$$

Effective pressure angle, α_{eD} , drive side

$$\alpha_{eD} = \alpha_{nD} - \alpha_{lim} = 20^\circ \quad (\text{F.171})$$

Effective pressure angle, α_{eC} , coast side

$$\alpha_{eC} = \alpha_{nC} + \alpha_{lim} = 20^\circ \quad (\text{F.172})$$

Outer pitch cone distance, R_{e2} , wheel

$$R_{e2} = R_{m2} + c_{be2} b_2 = 91,468 \text{ mm} \quad (\text{F.173})$$

Inner pitch cone distance, R_{i2} , wheel

$$R_{i2} = R_{e2} - b_2 = 61,468 \text{ mm} \quad (\text{F.174})$$

Outer pitch diameter, d_{e2} , wheel

$$d_{e2} = 2R_{e2} \sin \delta_2 = 170 \text{ mm} \quad (\text{F.175})$$

Inner pitch diameter, d_{i2} , wheel

$$d_{i2} = 2R_{i2} \sin \delta_2 = 114,243 \text{ mm} \quad (\text{F.176})$$

Outer transverse module, m_{et2}

$$m_{et2} = \frac{d_{e2}}{z_2} = 4,047 \text{ mm} \quad (\text{F.177})$$

Wheel face width from calculation point to outside, b_{e2}

$$b_{e2} = R_{e2} - R_{m2} = 15,1314 \text{ mm} \quad (\text{F.178})$$

Wheel face width from calculation point to inside, b_{i2}

$$b_{i2} = R_{m2} - R_{i2} = 14,869 \text{ mm} \quad (\text{F.179})$$

Crossing point to calculation point along wheel axis, t_{zm2}

$$t_{zm2} = \frac{d_{m1} \sin \delta_2}{2 \cos \delta_1} - 0,5 \cos \zeta_m \tan \Delta \Sigma \left(d_{m2} + \frac{d_{m1} \cos \delta_2}{\cos \delta_1} \right) = 26,621 \text{ mm} \quad (\text{F.180})$$

Crossing point to calculation point along pinion axis, t_{zm1}

$$t_{zm1} = \frac{d_{m2}}{2} \cos \zeta_m \cos \Delta \Sigma - t_{zm2} \sin \Delta \Sigma = 69,727 \text{ mm} \quad (\text{F.181})$$

Pitch apex beyond crossing point along axis, $t_{z1,2}$

$$t_{z1} = R_{m1} \cos \delta_1 - t_{zm1} = -1,225 \text{ mm} \quad (\text{F.182})$$

$$t_{z2} = R_{m2} \cos \delta_2 - t_{zm2} = 1,576 \text{ mm} \quad (\text{F.183})$$

F.3.4 Determination of tooth depth at calculation point

Mean working depth, h_{mw}

$$h_{mw} = 2m_{mn} k_{hap} = 5,280 \text{ mm} \quad (\text{F.184})$$

Mean addendum, h_{am2} , wheel

$$h_{am2} = m_{mn} (k_{hap} - x_{hm1}) = 1,848 \text{ mm} \quad (\text{F.185})$$

Mean dedendum, h_{fm2} , wheel

$$h_{fm2} = m_{mn} (k_{hfp} + x_{hm1}) = 4,092 \text{ mm} \quad (\text{F.186})$$

Mean addendum, h_{am1} , pinion

$$h_{am1} = m_{mn} (k_{hap} + x_{hm1}) = 3,432 \text{ mm} \quad (\text{F.187})$$

Mean dedendum, h_{fm1} , pinion

$$h_{fm1} = m_{mn} (k_{hfp} - x_{hm1}) = 2,508 \text{ mm} \quad (\text{F.188})$$

Clearance, c

$$c = m_{mn} (k_{hfp} - k_{hap}) = 0,660 \text{ mm} \quad (\text{F.189})$$

Mean whole depth, h_m

$$h_m = h_{am1,2} + h_{fm1,2} = 5,939 \text{ mm} \quad (\text{F.190})$$

$$h_m = m_{mn} (k_{hap} + k_{hfp}) = 5,939 \text{ mm} \quad (\text{F.191})$$

F.3.5 Determination of root angles and face angles

Face angle, δ_{a2} , wheel

$$\delta_{a2} = \delta_2 + \theta_{a2} = 69,323^\circ \quad (\text{F.192})$$

Root angle, δ_{f2} , wheel

$$\delta_{f2} = \delta_2 - \theta_{f2} = 64,324^\circ \quad (\text{F.193})$$

Auxiliary angle for calculating pinion offset angle in root plane, φ_R

$$\varphi_R = \arctan \left(\frac{a \tan \Delta \Sigma \cos \delta_{f2}}{R_{m2} \cos \theta_{f2} - t_{z2} \cos \delta_{f2}} \right) = 0,000^\circ \quad (\text{F.194})$$

Auxiliary angle for calculating pinion offset angle in face plane, φ_o

$$\varphi_o = \arctan \left(\frac{a \tan \Delta \Sigma \cos \delta_{a2}}{R_{m2} \cos \theta_{a2} - t_{z2} \cos \delta_{a2}} \right) = 0,000^\circ \quad (\text{F.195})$$

Pinion offset angle in root plane, ζ_R

$$\zeta_R = \arcsin \left(\frac{a \cos \varphi_R \sin \delta_{f2}}{R_{m2} \cos \theta_{f2} - t_{z2} \cos \delta_{f2}} \right) - \varphi_R = 10,319^\circ \quad (\text{F.196})$$

Pinion offset angle in face plane, ζ_o

$$\zeta_o = \arcsin \left(\frac{a \cos \varphi_o \sin \delta_{a2}}{R_{m2} \cos \theta_{a2} - t_{z2} \cos \delta_{a2}} \right) - \varphi_o = 10,674^\circ \quad (\text{F.197})$$

Face angle, δ_{a1} , pinion

$$\delta_{a1} = \arcsin \left(\sin \Delta \Sigma \sin \delta_{f2} + \cos \Delta \Sigma \cos \delta_{f2} \cos \zeta_R \right) = 25,232^\circ \quad (\text{F.198})$$

Root angle, δ_{f1} , pinion

$$\delta_{f1} = \arcsin \left(\sin \Delta \Sigma \sin \delta_{a2} + \cos \Delta \Sigma \cos \delta_{a2} \cos \zeta_o \right) = 20,303^\circ \quad (\text{F.199})$$

Addendum angle, θ_{a1} , pinion

$$\theta_{a1} = \delta_{a1} - \delta_1 = 3,943^\circ \quad (\text{F.200})$$

Dedendum angle, θ_{f1} , pinion

$$\theta_{f1} = \delta_1 - \delta_{f1} = 0,985^\circ \quad (\text{F.201})$$

Wheel face apex beyond crossing point along wheel axis, t_{zF2}

$$t_{zF2} = t_{z2} - \frac{R_{m2} \sin\theta_{a2} - h_{am2} \cos\theta_{a2}}{\sin\delta_{a2}} = 2,126 \text{ mm} \quad (\text{F.202})$$

Wheel root apex beyond crossing point along wheel axis, t_{zR2}

$$t_{zR2} = t_{z2} + \frac{R_{m2} \sin\theta_{f2} - h_{fm2} \cos\theta_{f2}}{\sin\delta_{f2}} = 2,955 \text{ mm} \quad (\text{F.203})$$

Pinion face apex beyond crossing point along pinion axis, t_{zF1}

$$t_{zF1} = \frac{a \sin\zeta_R \cos\delta_{f2} - t_{zR2} \sin\delta_{f2} - c}{\sin\delta_{a1}} = -5,064 \text{ mm} \quad (\text{F.204})$$

Pinion root apex beyond crossing point along pinion axis, t_{zR1}

$$t_{zR1} = \frac{a \sin\zeta_o \cos\delta_{a2} - t_{zF2} \sin\delta_{a2} - c}{\sin\delta_{f1}} = -4,808 \text{ mm} \quad (\text{F.205})$$

F.3.6 Determination of pinion face width, b_1

Pinion face width in pitch plane, b_{p1}

$$b_{p1} = \sqrt{R_{e2}^2 - a_p^2} - \sqrt{R_{i2}^2 - a_p^2} = 30,626 \text{ mm} \quad (\text{F.206})$$

Pinion face width from calculation point to front crown, b_{1A}

$$b_{1A} = \sqrt{R_{m2}^2 - a_p^2} - \sqrt{R_{i2}^2 - a_p^2} = 15,243 \text{ mm} \quad (\text{F.207})$$

Method 1:

Auxiliary angle, λ'

$$\lambda' = \arctan\left(\frac{\sin\zeta_{mp} \cos\delta_2}{u \cos\delta_1 + \cos\delta_2 \cos\zeta_{mp}}\right) = 1,239^\circ \quad (\text{F.208})$$

Pinion face width, $b_{\text{rer}i1}$

$$b_{\text{rer}i1} = \frac{b_2 \cos\lambda'}{\cos(\zeta_{mp} - \lambda')} = 30,470 \text{ mm} \quad (\text{F.209})$$

Pinion face width increment along pinion axis, Δb_{x1}

$$\Delta b_{x1} = h_{mw} \sin\zeta_R \left(1 - \frac{1}{u}\right) = 0,653 \text{ mm} \quad (\text{F.210})$$

Increment along pinion axis from calculation point to outside, Δg_{xe}

$$\Delta g_{xe} = \frac{c_{be2} b_{\text{rer}i1}}{\cos\theta_{a1}} \cos\delta_{a1} + \Delta b_{x1} - (h_{fm2} - c) \sin\delta_1 = 13,342 \text{ mm} \quad (\text{F.211})$$

Increment along pinion axis from calculation point to inside, Δg_{xi}

$$\Delta g_{xi} = \frac{(1 - c_{be2}) b_{rer1}}{\cos\theta_{a1}} \cos\delta_{a1} + \Delta b_{x1} + (h_{fm2} - c) \sin\delta_1 = 15,592 \text{ mm} \quad (\text{F.212})$$

Pinion face width from calculation point to outside, b_{e1}

$$b_{e1} = \frac{\Delta g_{xe} + h_{am1} \sin\delta_1}{\cos\delta_{a1}} \cos\theta_{a1} = 16,089 \text{ mm} \quad (\text{F.213})$$

Pinion face width from calculation point to inside, b_{i1}

$$b_{i1} = \frac{\Delta g_{xi} - h_{am1} \sin\delta_1}{\cos\delta_1 - \tan\theta_{a1} \sin\delta_1} = 15,822 \text{ mm} \quad (\text{F.214})$$

Pinion face width along pitch cone, b_1

$$b_1 = b_{i1} + b_{e1} = 31,910 \text{ mm} \quad (\text{F.215})$$

F.3.7 Determination of inner and outer spiral angles

F.3.7.1 Pinion

Wheel cone distance of outer pinion boundary point, R_{e21} (may be larger than R_{e2})

$$R_{e21} = \sqrt{R_{m2}^2 + b_{e1}^2 + 2R_{m2} b_{e1} \cos\zeta_{mp}} = 92,163 \text{ mm} \quad (\text{F.216})$$

Wheel cone distance of inner pinion boundary point, R_{i21} (may be smaller than R_{i2})

$$R_{i21} = \sqrt{R_{m2}^2 + b_{i1}^2 - 2R_{m2} b_{i1} \cos\zeta_{mp}} = 60,907 \text{ mm} \quad (\text{F.217})$$

Face milling:

Wheel spiral angle at outer boundary point, β_{e21}

$$\beta_{e21} = \arcsin\left(\frac{2R_{m2} r_{c0} \sin\beta_{m2} - R_{m2}^2 + R_{e21}^2}{2R_{e21} r_{c0}}\right) = 48,130^\circ \quad (\text{F.218})$$

Wheel spiral angle at inner boundary point, β_{i21}

$$\beta_{i21} = \arcsin\left(\frac{2R_{m2} r_{c0} \sin\beta_{m2} - R_{m2}^2 + R_{i21}^2}{2R_{i21} r_{c0}}\right) = 30,549^\circ \quad (\text{F.219})$$

Face hobbing and face milling:

Pinion offset angle in pitch plane at outer boundary point, ζ_{ep21}

$$\zeta_{ep21} = \arcsin\left(\frac{a_p}{R_{e21}}\right) = 9,414^\circ \quad (\text{F.220})$$

Pinion offset angle in pitch plane at inner boundary point, ζ_{ip21}

$$\zeta_{ip21} = \arcsin\left(\frac{a_p}{R_{i21}}\right) = 14,330^\circ \quad (\text{F.221})$$

Outer pinion spiral angle, β_{e1}

$$\beta_{e1} = \beta_{e21} + \zeta_{ep21} = 57,544^\circ \quad (\text{F.222})$$

Inner pinion spiral angle, β_{i1}

$$\beta_{i1} = \beta_{i21} + \zeta_{ip21} = 44,879^\circ \quad (\text{F.223})$$

F.3.7.2 Wheel

Face milling:

Outer wheel spiral angle, β_{e2}

$$\beta_{e2} = \arcsin\left(\frac{2R_{m2} r_{c0} \sin\beta_{m2} - R_{m2}^2 + R_{e2}^2}{2R_{e2} r_{c0}}\right) = 47,674^\circ \quad (\text{F.224})$$

Inner wheel spiral angle, β_{i2}

$$\beta_{i2} = \arcsin\left(\frac{2R_{m2} r_{c0} \sin\beta_{m2} - R_{m2}^2 + R_{i2}^2}{2R_{i2} r_{c0}}\right) = 30,826^\circ \quad (\text{F.225})$$

F.3.8 Determination of tooth depth

Outer addendum, h_{ae}

$$h_{ae1} = h_{am1} + b_{e1} \tan\theta_{a1} = 4,541 \text{ mm} \quad (\text{F.226})$$

$$h_{ae2} = h_{am2} + b_{e2} \tan\theta_{a2} = 2,112 \text{ mm} \quad (\text{F.227})$$

Outer dedendum, h_{fe}

$$h_{fe1} = h_{fm1} + b_{e1} \tan\theta_{f1} = 2,784 \text{ mm} \quad (\text{F.228})$$

$$h_{fe2} = h_{fm2} + b_{e2} \tan\theta_{f2} = 5,150 \text{ mm} \quad (\text{F.229})$$

Outer whole depth, h_e

$$h_{e1} = h_{ae1} + h_{fe1} = 7,325 \text{ mm} \quad (\text{F.230})$$

$$h_{e2} = h_{ae2} + h_{fe2} = 7,262 \text{ mm} \quad (\text{F.231})$$

Inner addendum, h_{ai}

$$h_{ai1} = h_{am1} - b_{i1} \tan \theta_{a1} = 2,341 \text{ mm} \quad (\text{F.232})$$

$$h_{ai2} = h_{am2} - b_{i2} \tan \theta_{a2} = 1,588 \text{ mm} \quad (\text{F.233})$$

Inner dedendum, h_{fi}

$$h_{fi1} = h_{fm1} - b_{i1} \tan \theta_{f1} = 2,236 \text{ mm} \quad (\text{F.234})$$

$$h_{fi2} = h_{fm2} - b_{i2} \tan \theta_{f2} = 3,052 \text{ mm} \quad (\text{F.235})$$

Inner whole depth, h_i

$$h_{i1} = h_{ai1} + h_{fi1} = 4,577 \text{ mm} \quad (\text{F.236})$$

$$h_{i2} = h_{ai2} + h_{fi2} = 4,640 \text{ mm} \quad (\text{F.237})$$

F.3.9 Determination of the tooth thickness

Mean normal pressure angle, α_n

$$\alpha_n = \frac{\alpha_{nD} + \alpha_{nC}}{2} = 20^\circ \quad (\text{F.238})$$

Thickness modification coefficient, x_{sm1} , pinion

with outer transverse backlash, j_{et2}

$$x_{sm1} = x_{smn} - j_{et2} \frac{R_{m2} \cos \beta_{m2}}{4 m_{mn} R_{e2}} = 0,038 \quad (\text{F.239})$$

Mean normal circular tooth thickness, s_{mn1} , pinion

$$s_{mn1} = 0,5 m_{mn} \pi + 2 m_{mn} (x_{sm1} + x_{hm1} \tan \alpha_n) = 4,922 \text{ mm} \quad (\text{F.240})$$

Thickness modification coefficient, x_{sm2} , wheel

with outer transverse backlash, j_{et2}

$$x_{sm2} = -x_{smn} - j_{et2} \frac{R_{m2} \cos \beta_{m2}}{4 m_{mn} R_{e2}} = -0,062 \quad (\text{F.241})$$

Mean normal circular tooth thickness, s_{mn2} , wheel

$$s_{mn2} = 0,5 m_{mn} \pi + 2 m_{mn} (x_{sm2} - x_{hm1} \tan \alpha_n) = 3,241 \text{ mm} \quad (\text{F.242})$$

Mean transverse circular thickness, s_{mt}

$$s_{mt1} = s_{mn1} / \cos \beta_{m1} = 7,656 \text{ mm} \quad (\text{F.243})$$

$$s_{mt2} = s_{mn2} / \cos \beta_{m2} = 4,147 \text{ mm} \quad (\text{F.244})$$

Mean normal diameter, d_{mn}

$$d_{mn1} = \frac{d_{m1}}{\left(1 - \sin^2 \beta_{m1} \cos^2 \alpha_n\right) \cos \delta_1} = 118,898 \text{ mm} \quad (\text{F.245})$$

$$d_{mn2} = \frac{d_{m2}}{\left(1 - \sin^2 \beta_{m2} \cos^2 \alpha_n\right) \cos \delta_2} = 585,370 \text{ mm} \quad (\text{F.246})$$

Mean normal chordal tooth thickness, s_{mnc}

$$s_{mnc1} = d_{mn1} \sin\left(s_{mn1} / d_{mn1}\right) = 4,917 \text{ mm} \quad (\text{F.247})$$

$$s_{mnc2} = d_{mn2} \sin\left(s_{mn2} / d_{mn2}\right) = 3,241 \text{ mm} \quad (\text{F.248})$$

Mean chordal addendum, h_{amc}

$$h_{amc1} = h_{am1} + 0,5 d_{mn1} \cos \delta_1 \left[1 - \cos\left(\frac{s_{mn1}}{d_{mn1}}\right)\right] = 3,432 \text{ mm} \quad (\text{F.249})$$

$$h_{amc2} = h_{am2} + 0,5 d_{mn2} \cos \delta_2 \left[1 - \cos\left(\frac{s_{mn2}}{d_{mn2}}\right)\right] = 1,849 \text{ mm} \quad (\text{F.250})$$

F.3.10 Determination of remaining gear dimensions

Outer pitch cone distance, R_{e1} , pinion

$$R_{e1} = R_{m1} + b_{e1} = 89,608 \text{ mm} \quad (\text{F.251})$$

Inner pitch cone distance, R_{i1} , pinion

$$R_{i1} = R_{m1} - b_{i1} = 57,697 \text{ mm} \quad (\text{F.252})$$

Outer pitch diameter, d_{e1} , pinion

$$d_{e1} = 2R_{e1} \sin \delta_1 = 65,065 \text{ mm} \quad (\text{F.253})$$

Inner pitch diameter, d_{i1} , pinion

$$d_{i1} = 2R_{i1} \sin \delta_1 = 41,895 \text{ mm} \quad (\text{F.254})$$

Outside diameter, d_{ae}

$$d_{ae1} = d_{e1} + 2h_{ae1} \cos \delta_1 = 73,528 \text{ mm} \quad (\text{F.255})$$

$$d_{ae2} = d_{e2} + 2h_{ae2} \cos \delta_2 = 171,560 \text{ mm} \quad (\text{F.256})$$

Diameter, d_{fe}

$$d_{fe1} = d_{e1} - 2h_{fe1} \cos \delta_1 = 59,877 \text{ mm} \quad (\text{F.257})$$

$$d_{fe2} = d_{e2} - 2h_{fe2} \cos \delta_2 = 166,196 \text{ mm} \quad (\text{F.258})$$

Diameter, d_{ai}

$$d_{ai1} = d_{i1} + 2h_{ai1} \cos \delta_1 = 46,258 \text{ mm} \quad (\text{F.259})$$

$$d_{ai2} = d_{i2} + 2h_{ai2} \cos \delta_2 = 115,416 \text{ mm} \quad (\text{F.260})$$

Diameter, d_{fi}

$$d_{fi1} = d_{i1} - 2h_{fi1} \cos \delta_1 = 37,730 \text{ mm} \quad (\text{F.261})$$

$$d_{fi2} = d_{i2} - 2h_{fi2} \cos \delta_2 = 111,989 \text{ mm} \quad (\text{F.262})$$

Crossing point to crown along axis, $t_{xo1,2}$

$$t_{xo1} = t_{zm1} + b_{e1} \cos \delta_1 - h_{ae1} \sin \delta_1 = 83,070 \text{ mm} \quad (\text{F.263})$$

$$t_{xo2} = t_{zm2} + b_{e2} \cos \delta_2 - h_{ae2} \sin \delta_2 = 30,247 \text{ mm} \quad (\text{F.264})$$

Crossing point to front crown along axis, $t_{xi1,2}$

$$t_{xi1} = t_{zm1} - b_{i1} \cos \delta_1 - h_{ai1} \sin \delta_1 = 54,135 \text{ mm} \quad (\text{F.265})$$

$$t_{xi2} = t_{zm2} - b_{i2} \cos \delta_2 - h_{ai2} \sin \delta_2 = 19,653 \text{ mm} \quad (\text{F.266})$$

Pinion whole depth, h_{t1} , perpendicular to the root cone

$$h_{t1} = \frac{t_{zF1} + t_{xo1}}{\cos \delta_{a1}} \sin(\theta_{a1} + \theta_{f1}) - (t_{zR1} - t_{zF1}) \sin \delta_{f1} = 7,320 \text{ mm} \quad (\text{F.267})$$

F.4 Sample hypoid gear set — Method 2

F.4.1 Initial data

This example uses Method 2 — Face hobbing tooth form.

Table F.7 — Initial data for calculation of pitch cone parameters

Symbol	Description	Method 0	Method 1	Method 2	Method 3
Σ	shaft angle	X	X	90°	X
a	hypoid offset	0,0	X	31,75 mm	X
$z_{1,2}$	number of teeth	X	X	9/34	X
d_{m2}	mean pitch diameter of wheel	—	—	146,7 mm	—

Table F.7 (continued)

Symbol	Description	Method 0	Method 1	Method 2	Method 3
d_{e2}	outer pitch diameter of wheel	X	X	—	X
b_2	wheel face width	X	X	26,0 mm	X
β_{m1}	mean spiral angle of pinion	—	X	—	—
β_{m2}	mean spiral angle of wheel	X	—	21,009°	X
r_{c0}	cutter radius	X	X	76,0 mm	X
z_0	number of blade groups (only face hobbing)	X	—	13	X

Table F.8 — Additional data for calculation of gear dimensions

Data type I		Data type II	
Symbol	Description	Symbol	Description
α_{dD}		20°	
α_{dC}		20°	
f_{alim}		1	
x_{hm1}	—	c_{ham}	0,275
k_{hap}	—	k_d	2,000
k_{hfp}	—	k_c	0,125
x_{smn}	—	k_t	0,1
		W_{m2}	—
j_{et2}		0,2 mm	
θ_{a2}		0°	
θ_{f2}		0°	

Table F.9 — Transformation of data type II into data type I

$x_{hm1} = k_d \left(\frac{1}{2} - c_{ham} \right) = 0,45$
$k_{hap} = \frac{k_d}{2} = 1$
$k_{hfp} = k_d \left(k_c + \frac{1}{2} \right) = 1,25$
$x_{smn} = \frac{k_t}{2} = 0,05$

F.4.2 Determination of pitch cone parameters

Lead angle of cutter, ν

$$\nu = \arcsin \left(\frac{z_0 d_{m2} \cos \beta_{m2}}{2 z_2 r_{c0}} \right) = 20,151^\circ \quad (\text{F.268})$$

First auxiliary angle, λ

$$\lambda = 90^\circ - \beta_{m2} + \nu = 89,142^\circ \quad (\text{F.269})$$

Gear ratio, u

$$u = \frac{z_2}{z_1} = 3,778 \quad (\text{F.270})$$

First approximate pinion pitch angle, δ_{1app}

$$\delta_{1app} = \arctan \left(\frac{\sin \Sigma}{u + \cos \Sigma} \right) = 14,826^\circ \quad (\text{F.271})$$

First approximate wheel pitch angle, δ_{2app}

$$\delta_{2app} = \Sigma - \delta_{1app} = 75,174^\circ \quad (\text{F.272})$$

First approximate pinion offset angle in axial plane, ζ_{mapp}

$$\zeta_{mapp} = \arcsin \left(\frac{\frac{2a}{d_{m2}}}{1 + \frac{\cos \delta_{2app}}{u \cos \delta_{1app}}} \right) = 23,861^\circ \quad (\text{F.273})$$

Approximate hypoid dimension factor, F_{app}

$$F_{app} = \frac{\cos \beta_{m2}}{\cos(\beta_{m2} + \zeta_{mapp})} = 1,317 \quad (\text{F.274})$$

Approximate pinion mean pitch diameter, d_{m1app}

$$d_{m1app} = \frac{F_{app} d_{m2}}{u} = 51,150 \text{ mm} \quad (\text{F.275})$$

Intermediate angle, φ_2

$$\varphi_2 = \arctan \left[\frac{u \cos \zeta_{mapp}}{\frac{u}{\tan \delta_{2app}} + (F_{app} - 1) \sin \Sigma} \right] = 69,130^\circ \quad (\text{F.276})$$

Approximate mean radius of crown gear, R_{mapp}

$$R_{mapp} = \frac{d_{m2}}{2 \sin \varphi_2} = 78,500 \text{ mm} \quad (\text{F.277})$$

Second auxiliary angle, η_1

$$\eta_1 = \arctan \left(\frac{r_{c0} \cos \nu - R_{mapp} \sin \beta_{m2}}{r_{c0} \sin \nu + R_{mapp} \cos \beta_{m2}} \right) = 23,479^\circ \quad (\text{F.278})$$

Intermediate angle, φ_3

$$\varphi_3 = \arctan \left[\frac{\tan(\beta_{m2} + \eta_1)}{\sin \varphi_2} \right] = 46,431^\circ \quad (\text{F.279})$$

Second approximate pinion pitch angle, δ_1''

$$\delta_1'' = \arctan \left[\frac{d_{m1app} \sin \Sigma}{d_{m2} \cos \zeta_{mapp} + d_{m1app} \cos \Sigma - \frac{2a}{\tan(\varphi_3 + \zeta_{mapp})}} \right] = 24,660^\circ \quad (\text{F.280})$$

Approximate wheel pitch angle, δ_2'' , projected into pinion axial plane along the common pitch plane

$$\delta_2'' = \Sigma - \delta_1'' = 65,340^\circ \quad (\text{F.281})$$

Start of iteration

Improved wheel pitch angle, δ_{2imp}

$$\delta_{2imp} = \arctan \left(\tan \delta_2'' \cos \zeta_{mapp} \right) = 63,343^\circ \quad (\text{F.282})$$

Auxiliary angle, η_p

$$\eta_p = \arctan \left[\frac{\sin \zeta_{mapp} \cos \delta_{2imp}}{\cos(\Sigma - \delta_{2imp})} \right] = 11,479^\circ \quad (\text{F.283})$$

Approximate wheel offset angle, η_{app}

$$\eta_{app} = \arctan \left[\frac{2a}{d_{m2} \tan \delta_{2imp} + d_{m1app} \frac{\cos \eta_p \sin(\beta_{m2} + \eta_1)}{\cos(\Sigma - \delta_{2imp})}} \right] = 10,843^\circ \quad (\text{F.284})$$

Improved pinion offset angle in axial plane, $\zeta_{m\text{ imp}}$

$$\zeta_{m\text{ imp}} = \arcsin \left[\frac{2a}{d_{m2}} - \frac{F_{\text{app}} \tan \eta_{\text{app}} \sin \delta_{2\text{ imp}} \cos \eta_{\text{p}}}{u \cos(\Sigma - \delta_{2\text{ imp}})} \right] = 21,556^\circ \quad (\text{F.285})$$

Improved pinion offset angle in pitch plane, $\zeta_{\text{mp imp}}$

$$\zeta_{\text{mp imp}} = \arctan \left[\frac{\tan \zeta_{m\text{ imp}} \sin \Sigma}{\cos(\Sigma - \delta_{2\text{ imp}})} \right] = 23,846^\circ \quad (\text{F.286})$$

Hypoid dimension factor, F

$$F = \frac{\cos \beta_{m2}}{\cos(\beta_{m2} + \zeta_{\text{mp imp}})} = 1,317 \quad (\text{F.287})$$

Pinion mean pitch diameter, d_{m1}

$$d_{m1} = \frac{F d_{m2}}{u} = 51,138 \text{ mm} \quad (\text{F.288})$$

Intermediate angle, φ_4

$$\varphi_4 = \arctan \left(\frac{\sin \lambda \sin \Sigma}{\frac{d_{m2}}{2r_{c0}} - \cos \lambda \sin \delta_{2\text{ imp}}} \right) = 46,413^\circ \quad (\text{F.289})$$

Improved pinion pitch angle, $\delta_{1''\text{ imp}}$

$$\delta_{1''\text{ imp}} = \arctan \left[\frac{d_{m1} \sin \Sigma}{d_{m2} \cos \zeta_{m\text{ imp}} + d_{m1} \cos \Sigma \cos \eta_{\text{p}} - \frac{2a}{\tan(\varphi_4 + \zeta_{m\text{ imp}})}} \right] = 24,786^\circ \quad (\text{F.290})$$

Improved wheel pitch angle, projected into pinion axial plane along the common pitch plane, $\delta_{2''\text{ imp}}$

$$\delta_{2''\text{ imp}} = \Sigma - \delta_{1''\text{ imp}} = 65,214^\circ \quad (\text{F.291})$$

Wheel pitch angle, δ_2

$$\delta_2 = \arctan \left(\tan \delta_{2''\text{ imp}} \cos \zeta_{\text{mp imp}} \right) = 63,212^\circ \quad (\text{F.292})$$

Intermediate angle, φ_5

$$\varphi_5 = \arctan \left(\frac{\tan \delta_2}{\cos \zeta_{m\text{ imp}}} \right) = 64,847^\circ \quad (\text{F.293})$$

Improved auxiliary angle, η_{pimp}

$$\eta_{\text{pimp}} = \arctan \left[\frac{\tan \eta_{\text{app}} \sin \varphi_5}{\cos(\Sigma - \varphi_5)} \right] = 10,843^\circ \quad (\text{F.294})$$

Wheel offset angle in axial plane, η

$$\eta = \arctan \left[\frac{2a}{d_{m2} \tan \delta_2 + d_{m1} \frac{\cos \eta_{\text{pimp}} \sin \varphi_5}{\cos(\Sigma - \varphi_5)}} \right] = 10,554^\circ \quad (\text{F.295})$$

Pinion offset angle in axial plane, ζ_m

$$\zeta_m = \arcsin(\tan \delta_2 \tan \eta) = 21,658^\circ \quad (\text{F.296})$$

Pinion offset angle in pitch plane, ζ_{mp}

$$\zeta_{\text{mp}} = \arctan \left[\frac{\tan \zeta_m \sin \Sigma}{\cos(\Sigma - \delta_2)} \right] = 23,981^\circ \quad (\text{F.297})$$

Pinion spiral angle, β_{m1}

$$\beta_{m1} = \beta_{m2} + \zeta_{\text{mp}} = 44,990^\circ \quad (\text{F.298})$$

Pinion mean pitch diameter, d_{m1}

$$d_{m1} = \frac{d_{m2} \cos \beta_{m2}}{u \cos \beta_{m1}} = 51,258 \text{ mm} \quad (\text{F.299})$$

Auxiliary angle, ξ

If $\Sigma \neq 90^\circ$:

$$\xi = \arctan(\tan \Sigma \cos \zeta_m) - \delta_2 \quad (\text{F.300})$$

If $\Sigma = 90^\circ$:

$$\xi = 90^\circ - \delta_2 = 26,788^\circ \quad (\text{F.301})$$

Pinion pitch angle, δ_1

$$\delta_1 = \arctan(\tan \xi \cos \zeta_{\text{mp}}) = 24,763^\circ \quad (\text{F.302})$$

Mean cone distance, R_{m1} , pinion

$$R_{m1} = \frac{d_{m1}}{2 \sin \delta_1} = 61,186 \text{ mm} \quad (\text{F.303})$$

Mean cone distance, R_{m2} , wheel

$$R_{m2} = \frac{d_{m2}}{2\sin\delta_2} = 82,168 \text{ mm} \quad (\text{F.304})$$

Crown gear to cutter centre distance, ρ_{P0}

$$\rho_{P0} = \sqrt{r_{c0}^2 + R_{m2}^2 - 2r_{c0} R_{m2} \cos\lambda} = 111,088 \text{ mm} \quad (\text{F.305})$$

Intermediate angle, φ_6

$$\varphi_6 = \arcsin\left(\frac{r_{c0} \sin\lambda}{\rho_{P0}}\right) = 43,162^\circ \quad (\text{F.306})$$

Complementary angle, φ_{comp}

$$\varphi_{\text{comp}} = 180^\circ - \zeta_{\text{mp}} - \varphi_6 = 112,856^\circ \quad (\text{F.307})$$

Checking variable, R_{mcheck}

$$R_{\text{mcheck}} = \frac{R_{m2} \sin\varphi_6}{\sin\varphi_{\text{comp}}} = 60,998 \text{ mm} \quad (\text{F.308})$$

$$\left| \frac{R_{m1}}{R_{\text{mcheck}}} - 1 \right| \leq 0,01$$

End of iteration

Face width factor, c_{be2}

$$c_{be2} = 0,5 \quad (\text{F.309})$$

F.4.3 Determination of basic data

Pinion mean pitch diameter, d_{m1}

$$d_{m1} = 2R_{m1} \sin\delta_1 = 51,258 \text{ mm} \quad (\text{F.310})$$

Wheel mean pitch diameter, d_{m2}

$$d_{m2} = 2R_{m2} \sin\delta_2 = 146,7 \text{ mm} \quad (\text{F.311})$$

Shaft angle departure from 90° , $\Delta\Sigma$

$$\Delta\Sigma = \Sigma - 90^\circ = 0^\circ \quad (\text{F.312})$$

Offset angle in the pinion axial plane, ζ_m

$$\zeta_m = \arcsin \left(\frac{2a}{d_{m2} + d_{m1} \frac{\cos \delta_2}{\cos \delta_1}} \right) = 21,647^\circ \quad (\text{F.313})$$

Offset angle in the pitch plane, ζ_{mp}

$$\zeta_{mp} = \arcsin \left(\frac{\sin \zeta_m \sin \Sigma}{\cos \delta_1} \right) = 23,969^\circ \quad (\text{F.314})$$

Offset in pitch plane, a_p

$$a_p = R_{m2} \sin \zeta_{mp} = 33,380 \text{ mm} \quad (\text{F.315})$$

Mean normal module, m_{mn}

$$m_{mn} = \frac{2R_{m2} \sin \delta_2 \cos \beta_{m2}}{z_2} = 4,028 \text{ mm} \quad (\text{F.316})$$

Limit pressure angle, α_{lim}

$$\alpha_{lim} = -\arctan \left[\frac{\tan \delta_1 \tan \delta_2 \left(\frac{R_{m1} \sin \beta_{m1} - R_{m2} \sin \beta_{m2}}{R_{m1} \tan \delta_1 + R_{m2} \tan \delta_2} \right)}{\cos \zeta_{mp}} \right] = -4,132^\circ \quad (\text{F.317})$$

Generated normal pressure angle, α_{nD} , drive side

$$\alpha_{nD} = \alpha_{dD} + f_{\alpha_{lim}} \alpha_{lim} = 15,868^\circ \quad (\text{F.318})$$

Generated normal pressure angle, α_{nC} , coast side

$$\alpha_{nC} = \alpha_{dC} - f_{\alpha_{lim}} \alpha_{lim} = 24,132^\circ \quad (\text{F.319})$$

Effective pressure angle, α_{eD} , drive side

$$\alpha_{eD} = 20^\circ \quad (\text{F.320})$$

Effective pressure angle, α_{eC} , coast side

$$\alpha_{eC} = 20^\circ \quad (\text{F.321})$$

Outer pitch cone distance, R_{e2} , wheel

$$R_{e2} = R_{m2} + c_{be2} b_2 = 95,168 \text{ mm} \quad (\text{F.322})$$

Inner pitch cone distance, R_{i2} , wheel

$$R_{i2} = R_{e2} - b_2 = 69,168 \text{ mm} \quad (\text{F.323})$$

Outer pitch diameter, d_{e2} , wheel

$$d_{e2} = 2R_{e2} \sin \delta_2 = 169,910 \text{ mm} \quad (\text{F.324})$$

Inner pitch diameter, d_{i2} , wheel

$$d_{i2} = 2R_{i2} \sin \delta_2 = 123,490 \text{ mm} \quad (\text{F.325})$$

Outer transverse module, m_{et2}

$$m_{et2} = \frac{d_{e2}}{z_2} = 4,997 \text{ mm} \quad (\text{F.326})$$

Wheel face width from calculation point to outside, b_{e2}

$$b_{e2} = R_{e2} - R_{m2} = 13,000 \text{ mm} \quad (\text{F.327})$$

Wheel face width from calculation point to inside, b_{i2}

$$b_{i2} = R_{m2} - R_{i2} = 13,000 \text{ mm} \quad (\text{F.328})$$

Crossing point to calculation point along wheel axis, t_{zm2}

$$t_{zm2} = \frac{d_{m1} \sin \delta_2}{2 \cos \delta_1} - 0,5 \cos \zeta_m \tan \Delta \Sigma \left(d_{m2} + \frac{d_{m1} \cos \delta_2}{\cos \delta_1} \right) = 25,195 \text{ mm} \quad (\text{F.329})$$

Crossing point to calculation point along pinion axis, t_{zm1}

$$t_{zm1} = \frac{d_{m2}}{2} \cos \zeta_m \cos \Delta \Sigma - t_{zm2} \sin \Delta \Sigma = 68,178 \text{ mm} \quad (\text{F.330})$$

Pitch apex beyond crossing point along axis, $t_{z1,2}$

$$t_{z1} = R_{m1} \cos \delta_1 - t_{zm1} = -12,618 \text{ mm} \quad (\text{F.331})$$

$$t_{z2} = R_{m2} \cos \delta_2 - t_{zm2} = 11,836 \text{ mm} \quad (\text{F.332})$$

F.4.4 Determination of tooth depth at calculation point

Mean working depth, h_{mw}

$$h_{mw} = 2m_{mn} k_{hap} = 8,056 \text{ mm} \quad (\text{F.333})$$

Mean addendum, h_{am2} , wheel

$$h_{am2} = m_{mn} (k_{hap} - x_{hm1}) = 2,215 \text{ mm} \quad (\text{F.334})$$

Mean dedendum, h_{fm2} , wheel

$$h_{fm2} = m_{mn} (k_{hfp} + x_{hm1}) = 6,847 \text{ mm} \quad (\text{F.335})$$

Mean addendum, h_{am1} , pinion

$$h_{am1} = m_{mn} (k_{hap} + x_{hm1}) = 5,840 \text{ mm} \quad (\text{F.336})$$

Mean dedendum, h_{fm1} , pinion

$$h_{fm1} = m_{mn} (k_{hfp} - x_{hm1}) = 3,222 \text{ mm} \quad (\text{F.337})$$

Clearance, c

$$c = m_{mn} (k_{hfp} - k_{hap}) = 1,007 \text{ mm} \quad (\text{F.338})$$

Mean whole depth, h_m

$$h_m = h_{am1,2} + h_{fm1,2} = 9,063 \text{ mm} \quad (\text{F.339})$$

$$h_m = m_{mn} (k_{hap} + k_{hfp}) = 9,063 \text{ mm} \quad (\text{F.340})$$

F.4.5 Determination of root angles and face angles

Face angle, δ_{a2} , wheel

$$\delta_{a2} = \delta_2 + \theta_{a2} = 63,212^\circ \quad (\text{F.341})$$

Root angle, δ_{f2} , wheel

$$\delta_{f2} = \delta_2 - \theta_{f2} = 63,212^\circ \quad (\text{F.342})$$

Auxiliary angle for calculating pinion offset angle in root plane, φ_R

$$\varphi_R = \arctan \left(\frac{a \tan \Delta \Sigma \cos \delta_{f2}}{R_{m2} \cos \theta_{f2} - t_{z2} \cos \delta_{f2}} \right) = 0,000^\circ \quad (\text{F.343})$$

Auxiliary angle for calculating pinion offset angle in face plane, φ_o

$$\varphi_o = \arctan \left(\frac{a \tan \Delta \Sigma \cos \delta_{a2}}{R_{m2} \cos \theta_{a2} - t_{z2} \cos \delta_{a2}} \right) = 0,000^\circ \quad (\text{F.344})$$

Pinion offset angle in root plane, ζ_R

$$\zeta_R = \arcsin \left(\frac{a \cos \varphi_R \sin \delta_{f2}}{R_{m2} \cos \theta_{f2} - t_{z2} \cos \delta_{f2}} \right) - \varphi_R = 21,647^\circ \quad (\text{F.345})$$

Pinion offset angle in face plane, ζ_o

$$\zeta_o = \arcsin \left(\frac{a \cos \varphi_o \sin \delta_{a2}}{R_{m2} \cos \theta_{a2} - t_{z2} \cos \delta_{a2}} \right) - \varphi_o = 21,647^\circ \quad (\text{F.346})$$

Face angle, δ_{a1} , pinion

$$\delta_{a1} = \arcsin\left(\sin\Delta\Sigma \sin\delta_{f2} + \cos\Delta\Sigma \cos\delta_{f2} \cos\zeta_R\right) = 24,765^\circ \quad (\text{F.347})$$

Root angle, δ_{f1} , pinion

$$\delta_{f1} = \arcsin\left(\sin\Delta\Sigma \sin\delta_{a2} + \cos\Delta\Sigma \cos\delta_{a2} \cos\zeta_o\right) = 24,765^\circ \quad (\text{F.348})$$

Addendum angle, θ_{a1} , pinion

$$\theta_{a1} = \delta_{a1} - \delta_1 = 0,002^\circ \quad (\text{F.349})$$

Dedendum angle, θ_{f1} , pinion

$$\theta_{f1} = \delta_1 - \delta_{f1} = -0,002^\circ \quad (\text{F.350})$$

Wheel face apex beyond crossing point along wheel axis, t_{zF2}

$$t_{zF2} = t_{z2} - \frac{R_{m2} \sin\theta_{a2} - h_{am2} \cos\theta_{a2}}{\sin\delta_{a2}} = 14,318 \text{ mm} \quad (\text{F.351})$$

Wheel root apex beyond crossing point along wheel axis, t_{zR2}

$$t_{zR2} = t_{z2} + \frac{R_{m2} \sin\theta_{f2} - h_{fm2} \cos\theta_{f2}}{\sin\delta_{f2}} = 4,166 \text{ mm} \quad (\text{F.352})$$

Pinion face apex beyond crossing point along pinion axis, t_{zF1}

$$t_{zF1} = \frac{a \sin\zeta_R \cos\delta_{f2} - t_{zR2} \sin\delta_{f2} - c}{\sin\delta_{a1}} = 1,319 \text{ mm} \quad (\text{F.353})$$

Pinion root apex beyond crossing point along pinion axis, t_{zR1}

$$t_{zR1} = \frac{a \sin\zeta_o \cos\delta_{a2} - t_{zF2} \sin\delta_{a2} - c}{\sin\delta_{f1}} = -20,315 \text{ mm} \quad (\text{F.354})$$

F.4.6 Determination of the pinion face width, b_1

Pinion face width in pitch plane, b_{p1}

$$b_{p1} = \sqrt{R_{e2}^2 - a_p^2} - \sqrt{R_{i2}^2 - a_p^2} = 28,542 \text{ mm} \quad (\text{F.355})$$

Pinion face width from calculation point to front crown, b_{1A}

$$b_{1A} = \sqrt{R_{m2}^2 - a_p^2} - \sqrt{R_{i2}^2 - a_p^2} = 14,502 \text{ mm} \quad (\text{F.356})$$

Method 2:

Pinion face width along pitch cone, b_1

$$b_1 = b_2 \left(1 + \tan^2\zeta_{mp}\right) = 31,139 \text{ mm} \quad (\text{F.357})$$

Pinion face width from calculation point to outside, b_{e1}

$$b_{e1} = c_{be2} b_1 = 15,569 \text{ mm} \quad (\text{F.358})$$

Pinion face width from calculation point to inside, b_{i1}

$$b_{i1} = b_1 - b_{e1} = 15,569 \text{ mm} \quad (\text{F.359})$$

F.4.7 Determination of inner and outer spiral angles

F.4.7.1 Pinion

Wheel cone distance of outer pinion boundary point, R_{e21} (may be larger than R_{e2})

$$R_{e21} = \sqrt{R_{m2}^2 + b_{e1}^2 + 2R_{m2} b_{e1} \cos \zeta_{mp}} = 96,602 \text{ mm} \quad (\text{F.360})$$

Wheel cone distance of inner pinion boundary point, R_{i21} (may be smaller than R_{i2})

$$R_{i21} = \sqrt{R_{m2}^2 + b_{i1}^2 - 2R_{m2} b_{i1} \cos \zeta_{mp}} = 68,235 \text{ mm} \quad (\text{F.361})$$

Face hobbing:

Lead angle of cutter, ν

$$\nu = \arcsin \left(\frac{z_0 m_{mn}}{2r_{c0}} \right) = 20,151^\circ \quad (\text{F.362})$$

Crown gear to cutter centre distance, ρ_{P0}

$$\rho_{P0} = \sqrt{R_{m2}^2 + r_{c0}^2 - 2R_{m2} r_{c0} \sin(\beta_{m2} - \nu)} = 111,088 \text{ mm} \quad (\text{F.363})$$

Epicycloid base circle radius, ρ_b

$$\rho_b = \frac{\rho_{P0}}{1 + \frac{z_0}{z_2} \sin \delta_2} = 82,820 \text{ mm} \quad (\text{F.364})$$

Auxiliary angle, φ_{e21}

$$\varphi_{e21} = \arccos \left(\frac{R_{e21}^2 + \rho_{P0}^2 - r_{c0}^2}{2R_{e21} \rho_{P0}} \right) = 42,213^\circ \quad (\text{F.365})$$

Auxiliary angle, φ_{i21}

$$\varphi_{i21} = \arccos \left(\frac{R_{i21}^2 + \rho_{P0}^2 - r_{c0}^2}{2R_{i21} \rho_{P0}} \right) = 42,257^\circ \quad (\text{F.366})$$

Wheel spiral angle at outer boundary point, β_{e21}

$$\beta_{e21} = \arctan \left(\frac{R_{e21} - \rho_b \cos \varphi_{e21}}{\rho_b \sin \varphi_{e21}} \right) = 32,362^\circ \quad (\text{F.367})$$

Wheel spiral angle at inner boundary point, β_{i21}

$$\beta_{i21} = \arctan \left(\frac{R_{i21} - \rho_b \cos \varphi_{i21}}{\rho_b \sin \varphi_{i21}} \right) = 7,101^\circ \quad (\text{F.368})$$

Face hobbing and face milling:

Pinion offset angle in pitch plane at outer boundary point, ζ_{ep21}

$$\zeta_{ep21} = \arcsin \left(\frac{a_p}{R_{e21}} \right) = 20,215^\circ \quad (\text{F.369})$$

Pinion offset angle in pitch plane at inner boundary point, ζ_{ip21}

$$\zeta_{ip21} = \arcsin \left(\frac{a_p}{R_{i21}} \right) = 29,287^\circ \quad (\text{F.370})$$

Outer pinion spiral angle, β_{e1}

$$\beta_{e1} = \beta_{e21} + \zeta_{ep21} = 52,576^\circ \quad (\text{F.371})$$

Inner pinion spiral angle, β_{i1}

$$\beta_{i1} = \beta_{i21} + \zeta_{ip21} = 36,388^\circ \quad (\text{F.372})$$

F.4.7.2 Wheel

Face hobbing:

Auxiliary angle, φ_{e2}

$$\varphi_{e2} = \arccos \left(\frac{R_{e2}^2 + \rho_{P0}^2 - r_{c0}^2}{2R_{e2} \rho_{P0}} \right) = 42,370^\circ \quad (\text{F.373})$$

Auxiliary angle, φ_{i2}

$$\varphi_{i2} = \arccos \left(\frac{R_{i2}^2 + \rho_{P0}^2 - r_{c0}^2}{2R_{i2} \rho_{P0}} \right) = 42,397^\circ \quad (\text{F.374})$$

Outer wheel spiral angle, β_{e2}

$$\beta_{e2} = \arctan \left(\frac{R_{e2} - \rho_b \cos \varphi_{e2}}{\rho_b \sin \varphi_{e2}} \right) = 31,334^\circ \quad (\text{F.375})$$

Inner wheel spiral angle, β_{i2}

$$\beta_{i2} = \arctan \left(\frac{R_{i2} - \rho_b \cos \varphi_{i2}}{\rho_b \sin \varphi_{i2}} \right) = 8,159^\circ \quad (\text{F.376})$$

F.4.8 Determination of tooth depth

Outer addendum, h_{ae}

$$h_{ae1} = h_{am1} + b_{e1} \tan \theta_{a1} = 5,841 \text{ mm} \quad (\text{F.377})$$

$$h_{ae2} = h_{am2} + b_{e2} \tan \theta_{a2} = 2,215 \text{ mm} \quad (\text{F.378})$$

Outer dedendum, h_{fe}

$$h_{fe1} = h_{fm1} + b_{e1} \tan \theta_{f1} = 3,222 \text{ mm} \quad (\text{F.379})$$

$$h_{fe2} = h_{fm2} + b_{e2} \tan \theta_{f2} = 6,847 \text{ mm} \quad (\text{F.380})$$

Outer whole depth, h_e

$$h_{e1} = h_{ae1} + h_{fe1} = 9,063 \text{ mm} \quad (\text{F.381})$$

$$h_{e2} = h_{ae2} + h_{fe2} = 9,063 \text{ mm} \quad (\text{F.382})$$

Inner addendum, h_{ai}

$$h_{ai1} = h_{am1} - b_{i1} \tan \theta_{a1} = 5,840 \text{ mm} \quad (\text{F.383})$$

$$h_{ai2} = h_{am2} - b_{i2} \tan \theta_{a2} = 2,215 \text{ mm} \quad (\text{F.384})$$

Inner dedendum, h_{fi}

$$h_{fi1} = h_{fm1} - b_{i1} \tan \theta_{f1} = 3,223 \text{ mm} \quad (\text{F.385})$$

$$h_{fi2} = h_{fm2} - b_{i2} \tan \theta_{f2} = 6,847 \text{ mm} \quad (\text{F.386})$$

Inner whole depth, h_i

$$h_{i1} = h_{ai1} + h_{fi1} = 9,063 \text{ mm} \quad (\text{F.387})$$

$$h_{i2} = h_{ai2} + h_{fi2} = 9,063 \text{ mm} \quad (\text{F.388})$$

F.4.9 Determination of the tooth thickness

Mean normal pressure angle, α_n

$$\alpha_n = \frac{\alpha_{nD} + \alpha_{nC}}{2} = 20,000^\circ \quad (\text{F.389})$$

Thickness modification coefficient, x_{sm1} , pinion

with outer transverse backlash, j_{et2}

$$x_{sm1} = x_{smn} - j_{et2} \frac{R_{m2} \cos\beta_{m2}}{4m_{mn} R_{e2}} = 0,040 \quad (\text{F.390})$$

Mean normal circular tooth thickness, s_{mn1} , pinion

$$s_{mn1} = 0,5m_{mn} \pi + 2m_{mn} (x_{sm1} + x_{hm1} \tan\alpha_n) = 7,969 \text{ mm} \quad (\text{F.391})$$

Thickness modification coefficient, x_{sm2} , wheel

with outer transverse backlash, j_{et2}

$$x_{sm2} = -x_{smn} - j_{et2} \frac{R_{m2} \cos\beta_{m2}}{4m_{mn} R_{e2}} = -0,060 \quad (\text{F.392})$$

Mean normal circular tooth thickness, s_{mn2} , wheel

$$s_{mn2} = 0,5m_{mn} \pi + 2m_{mn} (x_{sm2} - x_{hm1} \tan\alpha_n) = 4,524 \text{ mm} \quad (\text{F.393})$$

Mean transverse circular thickness, s_{mt}

$$s_{mt1} = s_{mn1} / \cos\beta_{m1} = 11,267 \text{ mm} \quad (\text{F.394})$$

$$s_{mt2} = s_{mn2} / \cos\beta_{m2} = 4,846 \text{ mm} \quad (\text{F.395})$$

Mean normal diameter, d_{mn}

$$d_{mn1} = \frac{d_{m1}}{(1 - \sin^2\beta_{m1} \cos^2\alpha_n) \cos\delta_1} = 101,047 \text{ mm} \quad (\text{F.396})$$

$$d_{mn2} = \frac{d_{m2}}{(1 - \sin^2\beta_{m2} \cos^2\alpha_n) \cos\delta_2} = 367,179 \text{ mm} \quad (\text{F.397})$$

Mean normal chordal tooth thickness, s_{mnc}

$$s_{mnc1} = d_{mn1} \sin(s_{mn1} / d_{mn1}) = 7,961 \text{ mm} \quad (\text{F.398})$$

$$s_{mnc2} = d_{mn2} \sin(s_{mn2} / d_{mn2}) = 4,524 \text{ mm} \quad (\text{F.399})$$

Mean chordal addendum, h_{amc}

$$h_{amc1} = h_{am1} + 0,5d_{mn1} \cos\delta_1 \left[1 - \cos\left(\frac{s_{mn1}}{d_{mn1}}\right) \right] = 5,982 \text{ mm} \quad (\text{F.400})$$

$$h_{amc2} = h_{am2} + 0,5d_{mn2} \cos\delta_2 \left[1 - \cos\left(\frac{s_{mn2}}{d_{mn2}}\right) \right] = 2,221 \text{ mm} \quad (\text{F.401})$$

F.4.10 Determination of remaining gear dimensions

Outer pitch cone distance, R_{e1} , pinion

$$R_{e1} = R_{m1} + b_{e1} = 76,755 \text{ mm} \quad (\text{F.402})$$

Inner pitch cone distance, R_{i1} , pinion

$$R_{i1} = R_{m1} - b_{i1} = 45,617 \text{ mm} \quad (\text{F.403})$$

Outer pitch diameter, d_{e1} , pinion

$$d_{e1} = 2R_{e1} \sin\delta_1 = 64,301 \text{ mm} \quad (\text{F.404})$$

Inner pitch diameter, d_{i1} , pinion

$$d_{i1} = 2R_{i1} \sin\delta_1 = 38,215 \text{ mm} \quad (\text{F.405})$$

Outside diameter, d_{ae}

$$d_{ae1} = d_{e1} + 2h_{ae1} \cos\delta_1 = 74,909 \text{ mm} \quad (\text{F.406})$$

$$d_{ae2} = d_{e2} + 2h_{ae2} \cos\delta_2 = 171,907 \text{ mm} \quad (\text{F.407})$$

Diameter, d_{fe}

$$d_{fe1} = d_{e1} - 2h_{fe1} \cos\delta_1 = 58,450 \text{ mm} \quad (\text{F.408})$$

$$d_{fe2} = d_{e2} - 2h_{fe2} \cos\delta_2 = 163,738 \text{ mm} \quad (\text{F.409})$$

Diameter, d_{ai}

$$d_{ai1} = d_{i1} + 2h_{ai1} \cos\delta_1 = 48,821 \text{ mm} \quad (\text{F.410})$$

$$d_{ai2} = d_{i2} + 2h_{ai2} \cos\delta_2 = 125,487 \text{ mm} \quad (\text{F.411})$$

Diameter, d_{fi}

$$d_{fi1} = d_{i1} - 2h_{fi1} \cos\delta_1 = 32,362 \text{ mm} \quad (\text{F.412})$$

$$d_{fi2} = d_{i2} - 2h_{fi2} \cos\delta_2 = 117,318 \text{ mm} \quad (\text{F.413})$$

Crossing point to crown along axis, $t_{xo1,2}$

$$t_{xo1} = t_{zm1} + b_{e1} \cos \delta_1 - h_{ae1} \sin \delta_1 = 79,869 \text{ mm} \quad (\text{F.414})$$

$$t_{xo2} = t_{zm2} + b_{e2} \cos \delta_2 - h_{ae2} \sin \delta_2 = 29,077 \text{ mm} \quad (\text{F.415})$$

Crossing point to front crown along axis, $t_{xi1,2}$

$$t_{xi1} = t_{zm1} - b_{i1} \cos \delta_1 - h_{ai1} \sin \delta_1 = 51,594 \text{ mm} \quad (\text{F.416})$$

$$t_{xi2} = t_{zm2} - b_{i2} \cos \delta_2 - h_{ai2} \sin \delta_2 = 17,359 \text{ mm} \quad (\text{F.417})$$

Pinion whole depth, h_{t1} , perpendicular to the root cone

$$h_{t1} = \frac{t_{zF1} + t_{xo1}}{\cos \delta_{a1}} \sin(\theta_{a1} + \theta_{f1}) - (t_{zR1} - t_{zF1}) \sin \delta_{f1} = 9,063 \text{ mm} \quad (\text{F.418})$$

F.5 Sample hypoid gear set — Method 3

F.5.1 Initial data

This example uses Method 3 — Face hobbing tooth form.

Table F.10 — Initial data for calculation of pitch cone parameters

Basic data for calculation of pitch cone parameters					
Symbol	Description	Method 0	Method 1	Method 2	Method 3
Σ	shaft angle	X	X	X	90°
a	hypoid offset	0,0	X	X	40 mm
$z_{1,2}$	number of teeth	X	X	X	12/49
d_{m2}	mean pitch diameter of wheel	—	—	X	—
d_{e2}	outer pitch diameter of wheel	X	X	—	400 mm
b_2	wheel face width	X	X	X	60 mm
β_{m1}	mean spiral angle of pinion	—	X	—	—
β_{m2}	mean spiral angle of wheel	X	—	X	30°
r_{c0}	cutter radius	X	X	X	135 mm
z_0	number of blade groups (only face hobbing)	X	—	X	5

Table F.11 — Additional data for calculation of gear dimensions

Data type I		Data type II	
Symbol	Description	Symbol	Description
α_{dD}		19°	
α_{dC}		21°	
f_{alim}		0	
x_{hm1}	0,2	c_{ham}	—
k_{hap}	1	k_d	—
k_{hfp}	1,25	k_c	—
x_{smn}	0,031	k_t	—
		W_{m2}	—
j_{et2}		0 mm	
θ_{a2}		0°	
θ_{f2}		0°	

Table F.12 — Transformation of data type I into data type II

$c_{ham} = \frac{1}{2} \left(1 - \frac{x_{hm1}}{k_{hap}} \right) = 0,4$
$k_d = 2k_{hap} = 2,000$
$k_c = \frac{1}{2} \left(\frac{k_{hfp}}{k_{hap}} - 1 \right) = 0,125$
$k_t = 2x_{smn} = 0,062$

F.5.2 Determination of pitch cone parameters

Gear ratio, u

$$u = \frac{z_2}{z_1} = 4,083 \quad (F.419)$$

For the iteration that follows, start with hypoid dimension factor, F

$$F = 1 \quad (F.420)$$

Wheel pitch angle, δ_2

$$\delta_2 = \arctan \left(\frac{\sin \Sigma}{\frac{F}{u} + \cos \Sigma} \right) = 76,239^\circ \quad (F.421)$$

Pinion pitch angle, δ_1

$$\delta_1 = \Sigma - \delta_2 = 13,761^\circ \quad (\text{F.422})$$

Start of iteration

***** **First trial** *****

Wheel mean pitch diameter, d_{m2}

$$d_{m2} = d_{e2} - b_2 \sin \delta_2 = 341,722 \text{ mm} \quad (\text{F.423})$$

Pinion offset angle in axial plane, ζ_m

$$\zeta_m = \arcsin \left[\frac{2a}{d_{m2} \left(1 + \frac{F \cos \delta_2}{u \cos \delta_1} \right)} \right] = 12,760^\circ \quad (\text{F.424})$$

Pinion pitch angle, δ_1

$$\delta_1 = \arcsin \left(\cos \zeta_m \sin \Sigma \cos \delta_2 - \cos \Sigma \sin \delta_2 \right) = 13,415^\circ \quad (\text{F.425})$$

Pinion offset angle in pitch plane, ζ_{mp}

$$\zeta_{mp} = \arcsin \left(\frac{\sin \zeta_m \sin \Sigma}{\cos \delta_1} \right) = 13,124^\circ \quad (\text{F.426})$$

Mean normal module, m_{mn}

$$m_{mn} = \frac{\cos \beta_{m2} d_{m2}}{z_2} = 6,040 \text{ mm} \quad (\text{F.427})$$

Spiral angle, β_{m1} , pinion

$$\beta_{m1} = \beta_{m2} + \zeta_{mp} = 43,124^\circ \quad (\text{F.428})$$

Hypoid dimension factor, F

$$F = \frac{\cos \beta_{m2}}{\cos \beta_{m1}} = 1,187 \quad (\text{F.429})$$

Pinion mean pitch diameter, d_{m1}

$$d_{m1} = \frac{d_{m2}}{u} F = 99,298 \text{ mm} \quad (\text{F.430})$$

Mean cone distance, R_{m1} , pinion

$$R_{m1} = \frac{d_{m1}}{2 \sin \delta_1} = 214,009 \text{ mm} \quad (\text{F.431})$$

Mean cone distance, R_{m2} , wheel

$$R_{m2} = \frac{d_{m2}}{2\sin\delta_2} = 175,910 \text{ mm} \quad (\text{F.432})$$

Lead angle of cutter, ν

$$\nu = \arcsin\left(\frac{z_0 m_{mn}}{2r_{c0}}\right) = 6,422^\circ \quad (\text{F.433})$$

Auxiliary angle, ϑ_m

$$\vartheta_m = \arctan(\sin\delta_2 \tan\zeta_m) = 12,405^\circ \quad (\text{F.434})$$

Intermediate variable, A_3

$$A_3 = r_{c0} \cos^2(\beta_{m2} - \nu) = 113,400 \text{ mm} \quad (\text{F.435})$$

Intermediate variable, A_4

$$A_4 = R_{m2} \cos(\beta_{m2} + \vartheta_m) \cos\beta_{m2} = 112,489 \text{ mm} \quad (\text{F.436})$$

Intermediate variable, A_5

$$A_5 = \sin\zeta_{mp} \cos\vartheta_m \cos\nu = 0,220 \quad (\text{F.437})$$

Intermediate variable, A_6

$$A_6 = R_{m2} \cos\beta_{m2} + r_{c0} \sin\nu = 167,442 \text{ mm} \quad (\text{F.438})$$

Intermediate variable, A_7

$$A_7 = \cos\beta_{m1} \cos(\beta_{m2} + \vartheta_m) - \frac{\sin(\beta_{m2} + \vartheta_m - \nu) \sin\zeta_{mp}}{\cos(\beta_{m2} - \nu)} = 0,393 \quad (\text{F.439})$$

Intermediate variable, $R_{m \text{ int}}$

$$R_{m \text{ int}} = \frac{A_3 A_4}{A_5 A_6 + A_3 A_7} = 156,504 \text{ mm} \quad (\text{F.440})$$

Check:

$$\left| R_{m \text{ int}} - R_{m1} \right| = 57,504 \text{ mm} > 0,000 1 R_{m1} = 0,021 \text{ mm}, \text{ next trial} \quad (\text{F.441})$$

Repeat the next loop of iteration with the following two improved values for δ_1 , δ_2 and the actual value for F .

Pinion pitch angle, δ_1

$$\delta_1 = \arcsin\left(\frac{d_{m1}}{2R_{m \text{ int}}}\right) = 18,496^\circ \quad (\text{F.442})$$

Wheel pitch angle, δ_2

$$\delta_2 = \arccos\left(\frac{\sin\delta_1 \cos\zeta_m \sin\Sigma + \cos\delta_1 \cos\zeta_{mp} \cos\Sigma}{1 - \sin^2\Sigma \sin^2\zeta_m}\right) = 71,018^\circ \quad (\text{F.443})$$

***** Last trial *****

Wheel mean pitch diameter, d_{m2}

$$d_{m2} = d_{e2} - b_2 \sin\delta_2 = 343,148 \text{ mm} \quad (\text{F.444})$$

Pinion offset angle in axial plane, ζ_m

$$\zeta_m = \arcsin\left[\frac{2a}{d_{m2} \left(1 + \frac{F \cos\delta_2}{u \cos\delta_1}\right)}\right] = 12,265^\circ \quad (\text{F.445})$$

Pinion pitch angle, δ_1

$$\delta_1 = \arcsin\left(\cos\zeta_m \sin\Sigma \cos\delta_2 - \cos\Sigma \sin\delta_2\right) = 18,201^\circ \quad (\text{F.446})$$

Pinion offset angle in pitch plane, ζ_{mp}

$$\zeta_{mp} = \arcsin\left(\frac{\sin\zeta_m \sin\Sigma}{\cos\delta_1}\right) = 12,922^\circ \quad (\text{F.447})$$

Mean normal module, m_{mn}

$$m_{mn} = \frac{\cos\beta_{m2} d_{m2}}{z_2} = 6,065 \text{ mm} \quad (\text{F.448})$$

Spiral angle, β_{m1} , pinion

$$\beta_{m1} = \beta_{m2} + \zeta_{mp} = 42,922^\circ \quad (\text{F.449})$$

Hypoid dimension factor, F

$$F = \frac{\cos\beta_{m2}}{\cos\beta_{m1}} = 1,183 \quad (\text{F.450})$$

Pinion mean pitch diameter, d_{m1}

$$d_{m1} = \frac{d_{m2}}{u} F = 99,384 \text{ mm} \quad (\text{F.451})$$

Mean cone distance, R_{m1} , pinion

$$R_{m1} = \frac{d_{m1}}{2\sin\delta_1} = 159,088 \text{ mm} \quad (\text{F.452})$$

Mean cone distance, R_{m2} , wheel

$$R_{m2} = \frac{d_{m2}}{2\sin\delta_2} = 181,074 \text{ mm} \quad (\text{F.453})$$

Lead angle of cutter, ν

$$\nu = \arcsin\left(\frac{z_0 m_{mn}}{2r_{c0}}\right) = 6,449^\circ \quad (\text{F.454})$$

Auxiliary angle, ϑ_m

$$\vartheta_m = \arctan(\sin\delta_2 \tan\zeta_m) = 11,640^\circ \quad (\text{F.455})$$

Intermediate variable, A_3

$$A_3 = r_{c0} \cos^2(\beta_{m2} - \nu) = 113,446 \text{ mm} \quad (\text{F.456})$$

Intermediate variable, A_4

$$A_4 = R_{m2} \cos(\beta_{m2} + \vartheta_m) \cos\beta_{m2} = 117,194 \text{ mm} \quad (\text{F.457})$$

Intermediate variable, A_5

$$A_5 = \sin\zeta_{mp} \cos\vartheta_m \cos\nu = 0,218 \quad (\text{F.458})$$

Intermediate variable, A_6

$$A_6 = R_{m2} \cos\beta_{m2} + r_{c0} \sin\nu = 171,977 \text{ mm} \quad (\text{F.459})$$

Intermediate variable, A_7

$$A_7 = \cos\beta_{m1} \cos(\beta_{m2} + \vartheta_m) - \frac{\sin(\beta_{m2} + \vartheta_m - \nu) \sin\zeta_{mp}}{\cos(\beta_{m2} - \nu)} = 0,407 \quad (\text{F.460})$$

Intermediate variable, $R_{m \text{ int}}$

$$R_{m \text{ int}} = \frac{A_3 A_4}{A_5 A_6 + A_3 A_7} = 159,100 \text{ mm} \quad (\text{F.461})$$

Check:

$$\left| R_{m \text{ int}} - R_{m1} \right| = 0,012 \text{ mm} < 0,0001 R_{m1} = 0,016 \text{ mm}, \text{ passed} \quad (\text{F.462})$$

Pinion pitch angle, δ_1

$$\delta_1 = \arcsin\left(\frac{d_{m1}}{2R_{m \text{ int}}}\right) = 18,200^\circ \quad (\text{F.463})$$

Wheel pitch angle, δ_2

$$\delta_2 = \arccos\left(\frac{\sin\delta_1 \cos\zeta_m \sin\Sigma + \cos\delta_1 \cos\zeta_{mp} \cos\Sigma}{1 - \sin^2\Sigma \sin^2\zeta_m}\right) = 71,360^\circ \quad (\text{F.464})$$

End of iteration

Face width factor, c_{be2}

$$c_{be2} = 0,5 \quad (\text{F.465})$$

F.5.3 Determination of basic data

Pinion mean pitch diameter, d_{m1}

$$d_{m1} = 2R_{m1} \sin\delta_1 = 99,377 \text{ mm} \quad (\text{F.466})$$

Wheel mean pitch diameter, d_{m2}

$$d_{m2} = 2R_{m2} \sin\delta_2 = 343,151 \text{ mm} \quad (\text{F.467})$$

Shaft angle departure from 90° , $\Delta\Sigma$

$$\Delta\Sigma = \Sigma - 90^\circ = 0^\circ \quad (\text{F.468})$$

Offset angle in the pinion axial plane, ζ_m

$$\zeta_m = \arcsin\left(\frac{2a}{d_{m2} + d_{m1} \frac{\cos\delta_2}{\cos\delta_1}}\right) = 12,265^\circ \quad (\text{F.469})$$

Offset angle in the pitch plane, ζ_{mp}

$$\zeta_{mp} = \arcsin\left(\frac{\sin\zeta_m \sin\Sigma}{\cos\delta_1}\right) = 12,922^\circ \quad (\text{F.470})$$

Offset in pitch plane, a_p

$$a_p = R_{m2} \sin\zeta_{mp} = 40,492 \quad (\text{F.471})$$

Mean normal module, m_{mn}

$$m_{mn} = \frac{2R_{m2} \sin\delta_2 \cos\beta_{m2}}{z_2} = 6,065 \text{ mm} \quad (\text{F.472})$$

Limit pressure angle, α_{lim}

$$\alpha_{\text{lim}} = -\arctan \left[\frac{\tan\delta_1 \tan\delta_2}{\cos\zeta_{\text{mp}}} \left(\frac{R_{\text{m1}} \sin\beta_{\text{m1}} - R_{\text{m2}} \sin\beta_{\text{m2}}}{R_{\text{m1}} \tan\delta_1 + R_{\text{m2}} \tan\delta_2} \right) \right] = -1,731^\circ \quad (\text{F.473})$$

Generated normal pressure angle, α_{nD} , drive side

$$\alpha_{\text{nD}} = \alpha_{\text{dD}} + f_{\alpha_{\text{lim}}} \alpha_{\text{lim}} = 19^\circ \quad (\text{F.474})$$

Generated normal pressure angle, α_{nC} , coast side

$$\alpha_{\text{nC}} = \alpha_{\text{dC}} - f_{\alpha_{\text{lim}}} \alpha_{\text{lim}} = 21^\circ \quad (\text{F.475})$$

Effective pressure angle, α_{eD} , drive side

$$\alpha_{\text{eD}} = \alpha_{\text{nD}} - \alpha_{\text{lim}} = 20,731^\circ \quad (\text{F.476})$$

Effective pressure angle, α_{eC} , coast side

$$\alpha_{\text{eC}} = \alpha_{\text{nC}} + \alpha_{\text{lim}} = 19,269^\circ \quad (\text{F.477})$$

Outer pitch cone distance, R_{e2} , wheel

$$R_{\text{e2}} = R_{\text{m2}} + c_{\text{be2}} b_2 = 211,072 \text{ mm} \quad (\text{F.478})$$

Inner pitch cone distance, R_{i2} , wheel

$$R_{\text{i2}} = R_{\text{e2}} - b_2 = 151,072 \text{ mm} \quad (\text{F.479})$$

Outer pitch diameter, d_{e2} , wheel

$$d_{\text{e2}} = 2R_{\text{e2}} \sin\delta_2 = 400 \text{ mm} \quad (\text{F.480})$$

Inner pitch diameter, d_{i2} , wheel

$$d_{\text{i2}} = 2R_{\text{i2}} \sin\delta_2 = 286,295 \text{ mm} \quad (\text{F.481})$$

Outer transverse module, m_{et2}

$$m_{\text{et2}} = \frac{d_{\text{e2}}}{z_2} = 8,163 \text{ mm} \quad (\text{F.482})$$

Wheel face width from calculation point to outside, b_{e2}

$$b_{\text{e2}} = R_{\text{e2}} - R_{\text{m2}} = 29,998 \text{ mm} \quad (\text{F.483})$$

Wheel face width from calculation point to inside, b_{i2}

$$b_{\text{i2}} = R_{\text{m2}} - R_{\text{i2}} = 30,002 \text{ mm} \quad (\text{F.484})$$

Crossing point to calculation point along wheel axis, t_{zm2}

$$t_{zm2} = \frac{d_{m1} \sin \delta_2}{2 \cos \delta_1} - 0,5 \cos \zeta_m \tan \Delta \Sigma \left(d_{m2} + \frac{d_{m1} \cos \delta_2}{\cos \delta_1} \right) = 49,561 \text{ mm} \quad (\text{F.485})$$

Crossing point to calculation point along pinion axis, t_{zm1}

$$t_{zm1} = \frac{d_{m2}}{2} \cos \zeta_m \cos \Delta \Sigma - t_{zm2} \sin \Delta \Sigma = 167,660 \text{ mm} \quad (\text{F.486})$$

Pitch apex beyond crossing point along axis, $t_{z1,2}$

$$t_{z1} = R_{m1} \cos \delta_1 - t_{zm1} = -16,530 \text{ mm} \quad (\text{F.487})$$

$$t_{z2} = R_{m2} \cos \delta_2 - t_{zm2} = 8,315 \text{ mm} \quad (\text{F.488})$$

F.5.4 Determination of tooth depth at calculation point

Mean working depth, h_{mw}

$$h_{mw} = 2m_{mn} k_{hap} = 12,130 \text{ mm} \quad (\text{F.489})$$

Mean addendum, h_{am2} , wheel

$$h_{am2} = m_{mn} (k_{hap} - x_{hm1}) = 4,852 \text{ mm} \quad (\text{F.490})$$

Mean dedendum, h_{fm2} , wheel

$$h_{fm2} = m_{mn} (k_{hfp} + x_{hm1}) = 8,794 \text{ mm} \quad (\text{F.491})$$

Mean addendum, h_{am1} , pinion

$$h_{am1} = m_{mn} (k_{hap} + x_{hm1}) = 7,278 \text{ mm} \quad (\text{F.492})$$

Mean dedendum, h_{fm1} , pinion

$$h_{fm1} = m_{mn} (k_{hfp} - x_{hm1}) = 6,368 \text{ mm} \quad (\text{F.493})$$

Clearance, c

$$c = m_{mn} (k_{hfp} - k_{hap}) = 1,516 \text{ mm} \quad (\text{F.494})$$

Mean whole depth, h_m

$$h_m = h_{am1,2} + h_{fm1,2} = 13,646 \quad (\text{F.495})$$

$$h_m = m_{mn} (k_{hap} + k_{hfp}) = 13,646 \quad (\text{F.496})$$

F.5.5 Determination of root angles and face angles

Face angle, δ_{a2} , wheel

$$\delta_{a2} = \delta_2 + \theta_{a2} = 71,360^\circ \quad (\text{F.497})$$

Root angle, δ_{f2} , wheel

$$\delta_{f2} = \delta_2 - \theta_{f2} = 71,360^\circ \quad (\text{F.498})$$

Auxiliary angle for calculating pinion offset angle in root plane, φ_R

$$\varphi_R = \arctan\left(\frac{a \tan\Delta\Sigma \cos\delta_{f2}}{R_{m2} \cos\theta_{f2} - t_{z2} \cos\delta_{f2}}\right) = 0,000^\circ \quad (\text{F.499})$$

Auxiliary angle for calculating pinion offset angle in face plane, φ_o

$$\varphi_o = \arctan\left(\frac{a \tan\Delta\Sigma \cos\delta_{a2}}{R_{m2} \cos\theta_{a2} - t_{z2} \cos\delta_{a2}}\right) = 0,000^\circ \quad (\text{F.500})$$

Pinion offset angle in root plane, ζ_R

$$\zeta_R = \arcsin\left(\frac{a \cos\varphi_R \sin\delta_{f2}}{R_{m2} \cos\theta_{f2} - t_{z2} \cos\delta_{f2}}\right) - \varphi_R = 12,265^\circ \quad (\text{F.501})$$

Pinion offset angle in face plane, ζ_o

$$\zeta_o = \arcsin\left(\frac{a \cos\varphi_o \sin\delta_{a2}}{R_{m2} \cos\theta_{a2} - t_{z2} \cos\delta_{a2}}\right) - \varphi_o = 12,265^\circ \quad (\text{F.502})$$

Face angle, δ_{a1} , pinion

$$\delta_{a1} = \arcsin\left(\sin\Delta\Sigma \sin\delta_{f2} + \cos\Delta\Sigma \cos\delta_{f2} \cos\zeta_R\right) = 18,200^\circ \quad (\text{F.503})$$

Root angle, δ_{f1} , pinion

$$\delta_{f1} = \arcsin\left(\sin\Delta\Sigma \sin\delta_{a2} + \cos\Delta\Sigma \cos\delta_{a2} \cos\zeta_o\right) = 18,200^\circ \quad (\text{F.504})$$

Addendum angle, θ_{a1} , pinion

$$\theta_{a1} = \delta_{a1} - \delta_1 = 0,000^\circ \quad (\text{F.505})$$

Dedendum angle, θ_{f1} , pinion

$$\theta_{f1} = \delta_1 - \delta_{f1} = 0,000^\circ \quad (\text{F.506})$$

Wheel face apex beyond crossing point along wheel axis, t_{zF2}

$$t_{zF2} = t_{z2} - \frac{R_{m2} \sin\theta_{a2} - h_{am2} \cos\theta_{a2}}{\sin\delta_{a2}} = 13,436 \text{ mm} \quad (\text{F.507})$$

Wheel root apex beyond crossing point along wheel axis, t_{zR2}

$$t_{zR2} = t_{z2} + \frac{R_{m2} \sin\theta_{f2} - h_{fm2} \cos\theta_{f2}}{\sin\delta_{f2}} = -0,966 \text{ mm} \quad (\text{F.508})$$

Pinion face apex beyond crossing point along pinion axis, t_{zF1}

$$t_{zF1} = \frac{a \sin\zeta_R \cos\delta_{f2} - t_{zR2} \sin\delta_{f2} - c}{\sin\delta_{a1}} = 6,771 \text{ mm} \quad (\text{F.509})$$

Pinion root apex beyond crossing point along pinion axis, t_{zR1}

$$t_{zR1} = \frac{a \sin\zeta_o \cos\delta_{a2} - t_{zF2} \sin\delta_{a2} - c}{\sin\delta_{f1}} = -36,920 \text{ mm} \quad (\text{F.510})$$

F.5.6 Determination of pinion face width, b_1

Pinion face width in pitch plane, b_{p1}

$$b_{p1} = \sqrt{R_{e2}^2 - a_p^2} - \sqrt{R_{i2}^2 - a_p^2} = 61,607 \text{ mm} \quad (\text{F.511})$$

Pinion face width from calculation point to front crown, b_{1A}

$$b_{1A} = \sqrt{R_{m2}^2 - a_p^2} - \sqrt{R_{i2}^2 - a_p^2} = 30,944 \text{ mm} \quad (\text{F.512})$$

Method 3:

Pinion face width along pitch cone, b_1

$$b_1 = \text{int}\left(b_{p1} + 3m_{mn} \tan|\zeta_{mp}| + 1\right) = 66,000 \text{ mm} \quad (\text{F.513})$$

Additional pinion face width, b_x

$$b_x = \frac{b_1 - b_{p1}}{2} = 2,196 \text{ mm} \quad (\text{F.514})$$

Pinion face width from calculation point to inside, b_{i1}

$$b_{i1} = b_{1A} + b_x = 33,140 \text{ mm} \quad (\text{F.515})$$

Pinion face width from calculation point to outside, b_{e1}

$$b_{e1} = b_1 - b_{i1} = 32,860 \text{ mm} \quad (\text{F.516})$$

F.5.7 Determination of inner and outer spiral angles

F.5.7.1 Pinion

Wheel cone distance of outer pinion boundary point, R_{e21} (may be larger than R_{e2})

$$R_{e21} = \sqrt{R_{m2}^2 + b_{e1}^2 + 2R_{m2} b_{e1} \cos\zeta_{mp}} = 213,228 \text{ mm} \quad (\text{F.517})$$

Wheel cone distance of inner pinion boundary point, R_{i21} (may be smaller than R_{i2})

$$R_{i21} = \sqrt{R_{m2}^2 + b_{i1}^2 - 2R_{m2} b_{i1} \cos \zeta_{mp}} = 148,957 \text{ mm} \quad (\text{F.518})$$

Face hobbing:

Lead angle of cutter, ν

$$\nu = \arcsin \left(\frac{z_0 m_{mn}}{2r_{c0}} \right) = 6,449^\circ \quad (\text{F.519})$$

Crown gear to cutter centre distance, ρ_{P0}

$$\rho_{P0} = \sqrt{R_{m2}^2 + r_{c0}^2 - 2R_{m2} r_{c0} \sin(\beta_{m2} - \nu)} = 177,420 \text{ mm} \quad (\text{F.520})$$

Epicycloid base circle radius, ρ_b

$$\rho_b = \frac{\rho_{P0}}{1 + \frac{z_0}{z_2} \sin \delta_2} = 161,778 \text{ mm} \quad (\text{F.521})$$

Auxiliary angle, φ_{e21}

$$\varphi_{e21} = \arccos \left(\frac{R_{e21}^2 + \rho_{P0}^2 - r_{c0}^2}{2R_{e21} \rho_{P0}} \right) = 39,098^\circ \quad (\text{F.522})$$

Auxiliary angle, φ_{i21}

$$\varphi_{i21} = \arcsin \left(\frac{R_{i21}^2 + \rho_{P0}^2 - r_{c0}^2}{2R_{i21} \rho_{P0}} \right) = 47,893^\circ \quad (\text{F.523})$$

Wheel spiral angle at outer boundary point, β_{e21}

$$\beta_{e21} = \arctan \left(\frac{R_{e21} - \rho_b \cos \varphi_{e21}}{\rho_b \sin \varphi_{e21}} \right) = 40,675^\circ \quad (\text{F.524})$$

Wheel spiral angle at inner boundary point, β_{i21}

$$\beta_{i21} = \arctan \left(\frac{R_{i21} - \rho_b \cos \varphi_{i21}}{\rho_b \sin \varphi_{i21}} \right) = 18,639^\circ \quad (\text{F.525})$$

Face hobbing and face milling:

Pinion offset angle in pitch plane at outer boundary point, ζ_{ep21}

$$\zeta_{ep21} = \arcsin \left(\frac{a_p}{R_{e21}} \right) = 10,947^\circ \quad (\text{F.526})$$

Pinion offset angle in pitch plane at inner boundary point, ζ_{ip21}

$$\zeta_{ip21} = \arcsin \left(\frac{a_p}{R_{i21}} \right) = 15,774^\circ \quad (\text{F.527})$$

Outer pinion spiral angle, β_{e1}

$$\beta_{e1} = \beta_{e21} + \zeta_{ep21} = 51,622^\circ \quad (\text{F.528})$$

Inner pinion spiral angle, β_{i1}

$$\beta_{i1} = \beta_{i21} + \zeta_{ip21} = 34,412^\circ \quad (\text{F.529})$$

F.5.7.2 Wheel

Face hobbing:

Auxiliary angle, φ_{e2}

$$\varphi_{e2} = \arccos \left(\frac{R_{e2}^2 + \rho_{P0}^2 - r_{c0}^2}{2R_{e2}\rho_{P0}} \right) = 39,485^\circ \quad (\text{F.530})$$

Auxiliary angle, φ_{i2}

$$\varphi_{i2} = \arccos \left(\frac{R_{i2}^2 + \rho_{P0}^2 - r_{c0}^2}{2R_{i2}\rho_{P0}} \right) = 47,703^\circ \quad (\text{F.531})$$

Outer wheel spiral angle, β_{e2}

$$\beta_{e2} = \arctan \left(\frac{R_{e2} - \rho_b \cos \varphi_{e2}}{\rho_b \sin \varphi_{e2}} \right) = 39,966^\circ \quad (\text{F.532})$$

Inner wheel spiral angle, β_{i2}

$$\beta_{i2} = \arctan \left(\frac{R_{i2} - \rho_b \cos \varphi_{i2}}{\rho_b \sin \varphi_{i2}} \right) = 19,426^\circ \quad (\text{F.533})$$

F.5.8 Determination of tooth depth

Outer addendum, h_{ae}

$$h_{ae1} = h_{am1} + b_{e1} \tan \theta_{a1} = 7,278 \text{ mm} \quad (\text{F.534})$$

$$h_{ae2} = h_{am2} + b_{e2} \tan \theta_{a2} = 4,852 \text{ mm} \quad (\text{F.535})$$

Outer dedendum, h_{fe}

$$h_{fe1} = h_{fm1} + b_{e1} \tan \theta_{f1} = 6,368 \text{ mm} \quad (\text{F.536})$$

$$h_{fe2} = h_{fm2} + b_{e2} \tan \theta_{f2} = 8,794 \text{ mm} \quad (\text{F.537})$$

Outer whole depth, h_e

$$h_{e1} = h_{ae1} + h_{fe1} = 13,646 \text{ mm} \quad (\text{F.538})$$

$$h_{e2} = h_{ae2} + h_{fe2} = 13,646 \text{ mm} \quad (\text{F.539})$$

Inner addendum, h_{ai}

$$h_{ai1} = h_{am1} - b_{i1} \tan \theta_{a1} = 7,278 \text{ mm} \quad (\text{F.540})$$

$$h_{ai2} = h_{am2} - b_{i2} \tan \theta_{a2} = 4,852 \text{ mm} \quad (\text{F.541})$$

Inner dedendum, h_{fi}

$$h_{fi1} = h_{fm1} - b_{i1} \tan \theta_{f1} = 6,368 \text{ mm} \quad (\text{F.542})$$

$$h_{fi2} = h_{fm2} - b_{i2} \tan \theta_{f2} = 8,794 \text{ mm} \quad (\text{F.543})$$

Inner whole depth, h_i

$$h_{i1} = h_{ai1} + h_{fi1} = 13,646 \text{ mm} \quad (\text{F.544})$$

$$h_{i2} = h_{ai2} + h_{fi2} = 13,646 \text{ mm} \quad (\text{F.545})$$

F.5.9 Determination of tooth thickness

Mean normal pressure angle, α_n

$$\alpha_n = \frac{\alpha_{nD} + \alpha_{nC}}{2} = 20,000^\circ \quad (\text{F.546})$$

Thickness modification coefficient, x_{sm1} , pinion

with outer transverse backlash, j_{et2}

$$x_{sm1} = x_{smn} - j_{et2} \frac{R_{m2} \cos \beta_{m2}}{4m_{mn} R_{e2}} = 0,031 \quad (\text{F.547})$$

Mean normal circular tooth thickness, s_{mn1} , pinion

$$s_{mn1} = 0,5m_{mn} \pi + 2m_{mn} (x_{sm1} + x_{hm1} \tan \alpha_n) = 10,786 \text{ mm} \quad (\text{F.548})$$

Thickness modification coefficient, x_{sm2} , wheel

with outer transverse backlash, j_{et2}

$$x_{sm2} = -x_{smn} - j_{et2} \frac{R_{m2} \cos \beta_{m2}}{4m_{mn} R_{e2}} = -0,031 \quad (\text{F.549})$$

Mean normal circular tooth thickness, s_{mn2} , wheel

$$s_{mn2} = 0,5m_{mn} \pi + 2m_{mn} (x_{sm2} - x_{hm1} \tan \alpha_n) = 8,268 \text{ mm} \quad (\text{F.550})$$

Mean transverse circular thickness, s_{mt}

$$s_{mt1} = s_{mn1} / \cos \beta_{m1} = 14,729 \text{ mm} \quad (\text{F.551})$$

$$s_{mt2} = s_{mn2} / \cos \beta_{m2} = 9,547 \text{ mm} \quad (\text{F.552})$$

Mean normal diameter, d_{mn}

$$d_{mn1} = \frac{d_{m1}}{\left(1 - \sin^2 \beta_{m1} \cos^2 \alpha_n\right) \cos \delta_1} = 177,158 \text{ mm} \quad (\text{F.553})$$

$$d_{mn2} = \frac{d_{m2}}{\left(1 - \sin^2 \beta_{m2} \cos^2 \alpha_n\right) \cos \delta_2} = 1377,740 \text{ mm} \quad (\text{F.554})$$

Mean normal chordal tooth thickness, s_{mnc}

$$s_{mnc1} = d_{mn1} \sin \left(s_{mn1} / d_{mn1} \right) = 10,779 \text{ mm} \quad (\text{F.555})$$

$$s_{mnc2} = d_{mn2} \sin \left(s_{mn2} / d_{mn2} \right) = 8,268 \text{ mm} \quad (\text{F.556})$$

Mean chordal addendum, h_{amc}

$$h_{amc1} = h_{am1} + 0,5d_{mn1} \cos \delta_1 \left[1 - \cos \left(\frac{s_{mn1}}{d_{mn1}} \right) \right] = 7,434 \text{ mm} \quad (\text{F.557})$$

$$h_{amc2} = h_{am2} + 0,5d_{mn2} \cos \delta_2 \left[1 - \cos \left(\frac{s_{mn2}}{d_{mn2}} \right) \right] = 4,855 \text{ mm} \quad (\text{F.558})$$

F.5.10 Determination of remaining gear dimensions

Outer pitch cone distance, R_{e1} , pinion

$$R_{e1} = R_{m1} + b_{e1} = 191,947 \text{ mm} \quad (\text{F.559})$$

Inner pitch cone distance, R_{i1} , pinion

$$R_{i1} = R_{m1} - b_{i1} = 125,947 \text{ mm} \quad (\text{F.560})$$

Outer pitch diameter, d_{e1} , pinion

$$d_{e1} = 2R_{e1} \sin \delta_1 = 119,903 \text{ mm} \quad (\text{F.561})$$

Inner pitch diameter, d_{i1} , pinion

$$d_{i1} = 2R_{i1} \sin \delta_1 = 78,675 \text{ mm} \quad (\text{F.562})$$

Outside diameter, d_{ae}

$$d_{ae1} = d_{e1} + 2h_{ae1} \cos \delta_1 = 133,730 \text{ mm} \quad (\text{F.563})$$

$$d_{ae2} = d_{e2} + 2h_{ae2} \cos \delta_2 = 403,102 \text{ mm} \quad (\text{F.564})$$

Diameter, d_{fe}

$$d_{fe1} = d_{e1} - 2h_{fe1} \cos \delta_1 = 107,804 \text{ mm} \quad (\text{F.565})$$

$$d_{fe2} = d_{e2} - 2h_{fe2} \cos \delta_2 = 394,378 \text{ mm} \quad (\text{F.566})$$

Diameter, d_{ai}

$$d_{ai1} = d_{i1} + 2h_{ai1} \cos \delta_1 = 92,502 \text{ mm} \quad (\text{F.567})$$

$$d_{ai2} = d_{i2} + 2h_{ai2} \cos \delta_2 = 289,396 \text{ mm} \quad (\text{F.568})$$

Diameter, d_{fi}

$$d_{fi1} = d_{i1} - 2h_{fi1} \cos \delta_1 = 66,576 \text{ mm} \quad (\text{F.569})$$

$$d_{fi2} = d_{i2} - 2h_{fi2} \cos \delta_2 = 280,673 \text{ mm} \quad (\text{F.570})$$

Crossing point to crown along axis, $t_{xo1,2}$

$$t_{xo1} = t_{zm1} + b_{e1} \cos \delta_1 - h_{ae1} \sin \delta_1 = 196,602 \text{ mm} \quad (\text{F.571})$$

$$t_{xo2} = t_{zm2} + b_{e2} \cos \delta_2 - h_{ae2} \sin \delta_2 = 54,552 \text{ mm} \quad (\text{F.572})$$

Crossing point to front crown along axis, $t_{xi1,2}$

$$t_{xi1} = t_{zm1} - b_{i1} \cos \delta_1 - h_{ai1} \sin \delta_1 = 133,904 \text{ mm} \quad (\text{F.573})$$

$$t_{xi2} = t_{zm2} - b_{i2} \cos \delta_2 - h_{ai2} \sin \delta_2 = 35,374 \text{ mm} \quad (\text{F.574})$$

Pinion whole depth, h_{t1} , perpendicular to the root cone

$$h_{t1} = \frac{t_{zF1} + t_{xo1}}{\cos \delta_{a1}} \sin(\theta_{a1} + \theta_{f1}) - (t_{zR1} - t_{zF1}) \sin \delta_{f1} = 13,646 \text{ mm} \quad (\text{F.575})$$

Bibliography

- [1] ISO 1122-1, *Vocabulary of gear terms — Part 1: Definitions related to geometry*
- [2] ISO 1328-1, *Cylindrical gears — ISO system of flank tolerance classification — Part 1: Definitions and allowable values of deviations relevant to flanks of gear teeth*
- [3] ISO 6336-5, *Calculation of load capacity of spur and helical gears — Part 5: Strength and quality of materials*
- [4] ISO 10300 (all parts), *Calculation of load capacity of bevel gears*

British Standards Institution (BSI)

BSI is the national body responsible for preparing British Standards and other standards-related publications, information and services.

BSI is incorporated by Royal Charter. British Standards and other standardization products are published by BSI Standards Limited.

About us

We bring together business, industry, government, consumers, innovators and others to shape their combined experience and expertise into standards-based solutions.

The knowledge embodied in our standards has been carefully assembled in a dependable format and refined through our open consultation process. Organizations of all sizes and across all sectors choose standards to help them achieve their goals.

Information on standards

We can provide you with the knowledge that your organization needs to succeed. Find out more about British Standards by visiting our website at bsigroup.com/standards or contacting our Customer Services team or Knowledge Centre.

Buying standards

You can buy and download PDF versions of BSI publications, including British and adopted European and international standards, through our website at bsigroup.com/shop, where hard copies can also be purchased.

If you need international and foreign standards from other Standards Development Organizations, hard copies can be ordered from our Customer Services team.

Copyright in BSI publications

All the content in BSI publications, including British Standards, is the property of and copyrighted by BSI or some person or entity that owns copyright in the information used (such as the international standardization bodies) and has formally licensed such information to BSI for commercial publication and use.

Save for the provisions below, you may not transfer, share or disseminate any portion of the standard to any other person. You may not adapt, distribute, commercially exploit, or publicly display the standard or any portion thereof in any manner whatsoever without BSI's prior written consent.

Storing and using standards

Standards purchased in soft copy format:

- A British Standard purchased in soft copy format is licensed to a sole named user for personal or internal company use only.
- The standard may be stored on more than 1 device provided that it is accessible by the sole named user only and that only 1 copy is accessed at any one time.
- A single paper copy may be printed for personal or internal company use only.

Standards purchased in hard copy format:

- A British Standard purchased in hard copy format is for personal or internal company use only.
- It may not be further reproduced – in any format – to create an additional copy. This includes scanning of the document.

If you need more than 1 copy of the document, or if you wish to share the document on an internal network, you can save money by choosing a subscription product (see 'Subscriptions').

Reproducing extracts

For permission to reproduce content from BSI publications contact the BSI Copyright & Licensing team.

Subscriptions

Our range of subscription services are designed to make using standards easier for you. For further information on our subscription products go to bsigroup.com/subscriptions.

With **British Standards Online (BSOL)** you'll have instant access to over 55,000 British and adopted European and international standards from your desktop. It's available 24/7 and is refreshed daily so you'll always be up to date.

You can keep in touch with standards developments and receive substantial discounts on the purchase price of standards, both in single copy and subscription format, by becoming a **BSI Subscribing Member**.

PLUS is an updating service exclusive to BSI Subscribing Members. You will automatically receive the latest hard copy of your standards when they're revised or replaced.

To find out more about becoming a BSI Subscribing Member and the benefits of membership, please visit bsigroup.com/shop.

With a **Multi-User Network Licence (MUNL)** you are able to host standards publications on your intranet. Licences can cover as few or as many users as you wish. With updates supplied as soon as they're available, you can be sure your documentation is current. For further information, email subscriptions@bsigroup.com.

Revisions

Our British Standards and other publications are updated by amendment or revision.

We continually improve the quality of our products and services to benefit your business. If you find an inaccuracy or ambiguity within a British Standard or other BSI publication please inform the Knowledge Centre.

Useful Contacts

Customer Services

Tel: +44 345 086 9001

Email (orders): orders@bsigroup.com

Email (enquiries): cservices@bsigroup.com

Subscriptions

Tel: +44 345 086 9001

Email: subscriptions@bsigroup.com

Knowledge Centre

Tel: +44 20 8996 7004

Email: knowledgecentre@bsigroup.com

Copyright & Licensing

Tel: +44 20 8996 7070

Email: copyright@bsigroup.com

BSI Group Headquarters

389 Chiswick High Road London W4 4AL UK