

BS ISO 23499:2013



BSI Standards Publication

Coal — Determination of bulk density for the use in charging of coke ovens

bsi.

...making excellence a habit.™

National foreword

This British Standard is the UK implementation of ISO 23499:2013. It supersedes BS ISO 23499:2008 which is withdrawn.

The UK participation in its preparation was entrusted to Technical Committee PTI/16, Solid mineral fuels.

A list of organizations represented on this committee can be obtained on request to its secretary.

This publication does not purport to include all the necessary provisions of a contract. Users are responsible for its correct application.

© The British Standards Institution 2013. Published by BSI Standards Limited 2013

ISBN 978 0 580 81998 8

ICS 73.040

Compliance with a British Standard cannot confer immunity from legal obligations.

This British Standard was published under the authority of the Standards Policy and Strategy Committee on 31 August 2013.

Amendments issued since publication

Date	Text affected
------	---------------

INTERNATIONAL
STANDARD

ISO
23499

Second edition
2013-07-01

**Coal — Determination of bulk density
for the use in charging of coke ovens**

*Charbon — Détermination de la masse volumique en vrac à des fins
d'enfournement dans les fours à coke*



Reference number
ISO 23499:2013(E)



COPYRIGHT PROTECTED DOCUMENT

© ISO 2013

All rights reserved. Unless otherwise specified, no part of this publication may be reproduced or utilized otherwise in any form or by any means, electronic or mechanical, including photocopying, or posting on the internet or an intranet, without prior written permission. Permission can be requested from either ISO at the address below or ISO's member body in the country of the requester.

ISO copyright office
Case postale 56 • CH-1211 Geneva 20
Tel. + 41 22 749 01 11
Fax + 41 22 749 09 47
E-mail copyright@iso.org
Web www.iso.org

Published in Switzerland

Contents

Page

Foreword	iv
Introduction	v
1 Scope	1
2 Normatives references	1
3 Terms and definitions	1
4 Principle	1
5 Samples and apparatus	1
5.1 General.....	1
5.2 Apparatus.....	2
6 Sampling	2
6.1 Test portion for bulk density.....	2
6.2 Test sample.....	2
7 Procedure	2
8 Expression of results	4
9 Reporting of results	5
10 Precision	5
10.1 Repeatability.....	5
10.2 Reproducibility.....	5
11 Test report	5
Bibliography	6

Foreword

ISO (the International Organization for Standardization) is a worldwide federation of national standards bodies (ISO member bodies). The work of preparing International Standards is normally carried out through ISO technical committees. Each member body interested in a subject for which a technical committee has been established has the right to be represented on that committee. International organizations, governmental and non-governmental, in liaison with ISO, also take part in the work. ISO collaborates closely with the International Electrotechnical Commission (IEC) on all matters of electrotechnical standardization.

The procedures used to develop this document and those intended for its further maintenance are described in the ISO/IEC Directives, Part 1. In particular the different approval criteria needed for the different types of ISO documents should be noted. This document was drafted in accordance with the editorial rules of the ISO/IEC Directives, Part 2. www.iso.org/directives

Attention is drawn to the possibility that some of the elements of this document may be the subject of patent rights. ISO shall not be held responsible for identifying any or all such patent rights. Details of any patent rights identified during the development of the document will be in the Introduction and/or on the ISO list of patent declarations received. www.iso.org/patents

Any trade name used in this document is information given for the convenience of users and does not constitute an endorsement.

The committee responsible for this document is ISO/TC 27, *Solid mineral fuels*, Subcommittee SC 1, *Coal preparation: Terminology and performance*.

This second edition cancels and replaces the first edition (ISO 23499:2008), which has been technically revised.

This International Standard is based, with permission of ASTM International, on ASTM D291, *Standard Test Method for Cubic Foot Weight of Crushed Bituminous Coal*, copyright ASTM International.

Introduction

The bulk density of coal is influenced by its physical characteristics, such as relative density, shape and size distribution of the coal particles, on the coal moisture content as well as on the dimensions of the measuring container. Since the results for coal bulk density change according to variations in the above factors, it is recommended that a separate size analysis and total moisture determination be made in accordance with ISO 1953 and ISO 589, respectively.

The present method describes a procedure for determining a reference bulk density for crushed coal such as that charged into coke ovens. When charging a coke oven, a knowledge of the mass of coal placed in the oven for maintaining a relatively constant oven charge is a requirement. This test is designed to obtain a degree of compaction of coal comparable to the densities attained in industrial coke ovens.

Coal — Determination of bulk density for the use in charging of coke ovens

1 Scope

This International Standard provides description of a cone procedure for determining an uncompacted bulk density of crushed coal less than 37 mm in size, such as is charged into coke ovens. It focuses on the uncompacted bulk density of coal resulting from flowing the material into a measuring container (box) in the absence of compacting forces.

This International Standard does not cover procedures for determining a compacted coal bulk density nor to the testing of fine or powdered coal (for boiler or utility application) nor to the determination of bulk density of coal in storage piles.

2 Normatives references

The following documents, in whole or in part, are normatively referenced in this document and are indispensable for its application. For dated references, only the edition cited applies. For undated references, the latest edition of the referenced document (including any amendments) applies.

ISO 589, *Hard coal — Determination of total moisture*

ISO 1213-1, *Solid mineral fuels — Vocabulary — Part 1: Terms relating to coal preparation*

ISO 1213-2, *Solid mineral fuels — Vocabulary — Part 2: Terms relating to sampling, testing and analysis*

ISO 1953, *Hard coal — Size analysis by sieving*

ISO 13909-4, *Hard coal and coke — Mechanical sampling — Part 4: Coal — Preparation of test samples*

3 Terms and definitions

For the purposes of this document, the terms and definitions given in ISO 1213-1 and ISO 1213-2 apply.

4 Principle

The bulk density is determined by filling a weighed container (measuring box) of known volume with coal and determining the increase in mass.

5 Samples and apparatus

5.1 General

Samples containing fines can show significant variations in bulk density with variations in moisture. Care should be taken to ensure that moisture in the test sample is representative of the portion for bulk density.

5.2 Apparatus

5.2.1 Measuring box, a cubical container of $(0,028\ 4 \pm 0,000\ 082)$ m³ (1 ft³) capacity and internal dimensions of 305 mm (1 ft), with a smooth inner surface, rigidly constructed and fitted with handles. The exact volume of the box, in cubic metres, shall be determined using water of a known density.

The container shall be constructed of metal of sufficient thickness to ensure the rigidity of the walls and the base of the container under the conditions of the test. (Minimum wall thickness of 3 mm is recommended.)

NOTE The internal dimensions of the cubical container can be “rounded off” to 300 mm with an acceptable tolerance, giving a volume of 0,027 m³. The most important criterion is to know the exact volume of the measuring box since it is critical for calculating the coal bulk density.

5.2.2 Cone, for filling the box, should conform to [Figure 1](#). The dimensions of this cone shall be as follows: 610 mm high with an inside diameter at the top of 510 mm and a circular opening of 115 mm in diameter at the bottom. A slide valve consisting of a slide-plate shutter and its supports shall be welded to the bottom of the cone in such a manner that the valve can be opened and closed with ease by removing or inserting the shutter in its supporting slides. The cone shall be supported in a tripod frame having a circular opening at the top of 460 mm in diameter. This frame shall support the cone so that the top side of the shutter shall be 560 mm from the inside bottom surface of the box (see [Figure 1](#)).

5.2.3 Levelling bar, a steel strip approximately 760 mm long by 40 mm wide and 5 mm thick.

5.2.4 Weighing device, a weighing platform capable of weighing up to 100 kg and sensitive to 0,05 kg.

6 Sampling

6.1 Test portion for bulk density

Crushed coal samples shall be collected in accordance with ISO 13909-4. During the collection of the test portion for bulk density, the increments of the sample shall be stored in an airtight container to prevent loss of moisture. The minimum mass of sample for bulk density shall be 150 kg, which is sufficient for four replicate determinations and the subsequent determination of total moisture.

6.2 Test sample

The test portion for bulk density shall be thoroughly mixed and subdivided, without crushing, into four 34 kg portions in accordance with ISO 13909-4. This operation shall be done as quickly as possible to avoid loss of moisture, and the bulk density shall be determined immediately. If the determination cannot be made immediately, the samples shall be kept in air-tight containers and waterproof with minimum airspace and with tightly fitting covers until the time for making the determination.

7 Procedure

7.1 Before filling the cone hopper with coal, level its tripod on a metal plate or solid floor. Pour the prepared sample into a pile on the floor and carefully flatten it using a shovel or scoop to about 100 mm in thickness. Avoid putting undue pressure on the coal with the back of the shovel or scoop. Take successive shovelfuls or scoopfuls from uniformly distributed points in the pile and allow them to slide gently from the shovel or scoop into the hopper at different peripheral points. This prevents segregation and packing while the hopper is being filled. Place about 34 kg of coal in the hopper.

7.2 Centre the previously weighed measuring box under the valve of the cone. Then remove the valve shutter completely, allowing all of the coal to flow into the box and overflow the edges. Loosen wet coal

not flowing freely from the hopper by gently thrusting downward through the coal to the valve with the levelling bar.

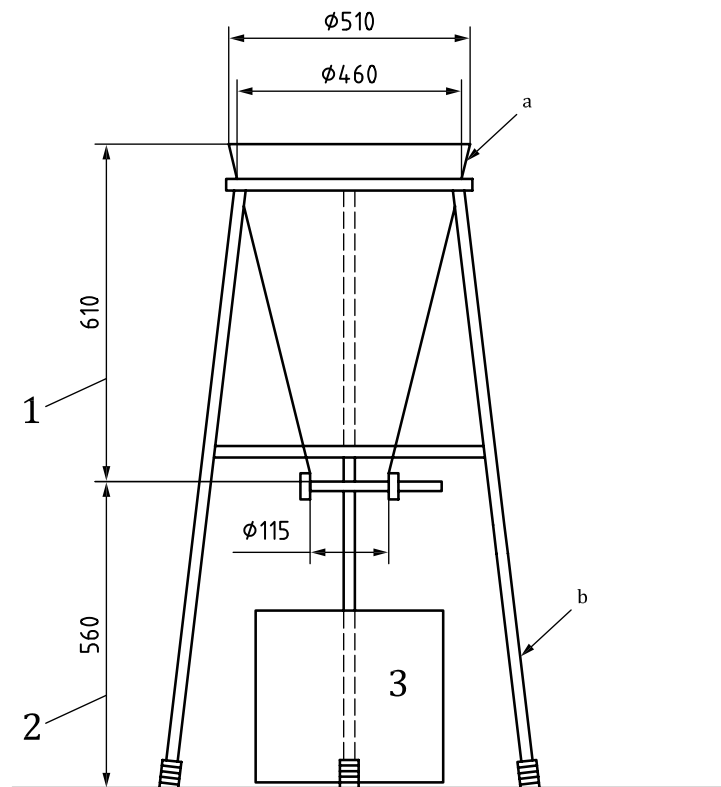
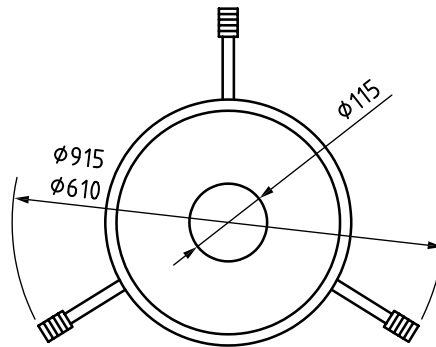

a) Complete apparatus

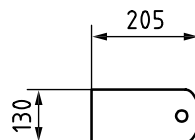

b) Iron shutter to fit the base of the hopper

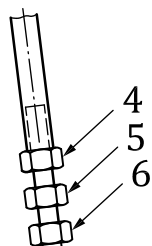

c) Detail of adjustable hopper leg

Key

- 1 cone height
- 2 height from iron shutter to internal base of measuring box
- 3 measuring box
- 4 nut
- 5 lock nut
- 6 M16 bolt
- a 1,6 mm steel
- b DN18 pipe

Figure 1 — Apparatus for cone procedure

7.3 After filling the box, carefully level off the excess coal above the box edge by means of the levelling bar, ensuring at the same time that all the corners of the box are filled. Avoid jarring or shifting the filled box until all the excess coal is levelled off. Place the measuring box on the platform scale and weigh it to the nearest 0,05 kg. Record the difference in mass between the filled and the empty box to the nearest 0,05 kg as the uncompacted mass of coal.

Aside from the character of the coal itself, moisture content and size distribution of the coal are the two main factors that affect its bulk density. The result of the moisture determination shall be included in the test report. It is also necessary that a sieve analysis of the coal be reported along with the bulk density for proper interpretation of the bulk density. See ISO 589 for details of the moisture determination and ISO 1953 for details of the size analysis by sieving.

8 Expression of results

The bulk density, $\rho_{B,dB}$, of the coal, expressed in kilograms per cubic metre, on a dry basis, is given by Formula (1):

$$\rho_{B,dB} = \frac{(m_1 - m_0)}{V} \times \frac{(100 - M)}{100} \tag{1}$$

where

- m_0 is the mass of the clean, dry measuring box, expressed in kilograms;
- m_1 is the mass of the filled measuring box, expressed in kilograms;
- V is the volume of the clean, dry measuring box, expressed in cubic metres;
- M is the total moisture of the coal, expressed as a percentage by mass, determined in accordance with ISO 589.

The bulk density, $\rho_{B,ar}$, of the coal, expressed in kilograms per cubic metre, on an “as received” basis, is given by Formula (2):

$$\rho_{B,ar} = \frac{(m_1 - m_0)}{V} \quad (2)$$

where the symbols are the same as for Formula (1).

9 Reporting of results

Each result shall be expressed in kilograms per cubic metre to one decimal place.

The reported mean value shall be the mean of duplicate determinations, and shall be given to the nearest whole number.

10 Precision

10.1 Repeatability

The results of duplicate determinations, carried out in the same laboratory by the same operator with the same apparatus on representative portions taken from the same test sample, should not differ by more than 10,0 kg/m³.

When two results are obtained that differ by more than this value, two additional tests shall be made. If the second pair of results meets the repeatability requirements, the first pair shall be discarded and the mean of the second pair shall be reported.

When both pairs of results exceed the repeatability, the mean of the four results shall be reported, provided that the two most divergent results differ by less than 13,0 kg/m³. Otherwise, all results shall be discarded and the apparatus, procedure, and sample shall be examined for causes of non-compliance, which shall be corrected before re-determining new pairs of values.

10.2 Reproducibility

No value for reproducibility can be quoted for determinations carried out in different laboratories because the transport of bulk coal samples involves the risk of breakage and, thus, alteration of the size distribution and the bulk density.

11 Test report

The test report shall include the following:

- a) reference to this International Standard;
- b) identification of the sampled tested;
- c) results and the moisture basis, e.g. $\rho_{B,db}$ and $\rho_{B,ar}$;
- d) moisture content and size distribution of the sample.

Bibliography

- [1] ASTM D291, *Standard Test Method for Cubic Foot Weight of Crushed Bituminous Coal*

British Standards Institution (BSI)

BSI is the national body responsible for preparing British Standards and other standards-related publications, information and services.

BSI is incorporated by Royal Charter. British Standards and other standardization products are published by BSI Standards Limited.

About us

We bring together business, industry, government, consumers, innovators and others to shape their combined experience and expertise into standards-based solutions.

The knowledge embodied in our standards has been carefully assembled in a dependable format and refined through our open consultation process. Organizations of all sizes and across all sectors choose standards to help them achieve their goals.

Information on standards

We can provide you with the knowledge that your organization needs to succeed. Find out more about British Standards by visiting our website at bsigroup.com/standards or contacting our Customer Services team or Knowledge Centre.

Buying standards

You can buy and download PDF versions of BSI publications, including British and adopted European and international standards, through our website at bsigroup.com/shop, where hard copies can also be purchased.

If you need international and foreign standards from other Standards Development Organizations, hard copies can be ordered from our Customer Services team.

Subscriptions

Our range of subscription services are designed to make using standards easier for you. For further information on our subscription products go to bsigroup.com/subscriptions.

With **British Standards Online (BSOL)** you'll have instant access to over 55,000 British and adopted European and international standards from your desktop. It's available 24/7 and is refreshed daily so you'll always be up to date.

You can keep in touch with standards developments and receive substantial discounts on the purchase price of standards, both in single copy and subscription format, by becoming a **BSI Subscribing Member**.

PLUS is an updating service exclusive to BSI Subscribing Members. You will automatically receive the latest hard copy of your standards when they're revised or replaced.

To find out more about becoming a BSI Subscribing Member and the benefits of membership, please visit bsigroup.com/shop.

With a **Multi-User Network Licence (MUNL)** you are able to host standards publications on your intranet. Licences can cover as few or as many users as you wish. With updates supplied as soon as they're available, you can be sure your documentation is current. For further information, email bsmusales@bsigroup.com.

BSI Group Headquarters

389 Chiswick High Road London W4 4AL UK

Revisions

Our British Standards and other publications are updated by amendment or revision.

We continually improve the quality of our products and services to benefit your business. If you find an inaccuracy or ambiguity within a British Standard or other BSI publication please inform the Knowledge Centre.

Copyright

All the data, software and documentation set out in all British Standards and other BSI publications are the property of and copyrighted by BSI, or some person or entity that owns copyright in the information used (such as the international standardization bodies) and has formally licensed such information to BSI for commercial publication and use. Except as permitted under the Copyright, Designs and Patents Act 1988 no extract may be reproduced, stored in a retrieval system or transmitted in any form or by any means – electronic, photocopying, recording or otherwise – without prior written permission from BSI. Details and advice can be obtained from the Copyright & Licensing Department.

Useful Contacts:

Customer Services

Tel: +44 845 086 9001

Email (orders): orders@bsigroup.com

Email (enquiries): cservices@bsigroup.com

Subscriptions

Tel: +44 845 086 9001

Email: subscriptions@bsigroup.com

Knowledge Centre

Tel: +44 20 8996 7004

Email: knowledgecentre@bsigroup.com

Copyright & Licensing

Tel: +44 20 8996 7070

Email: copyright@bsigroup.com



...making excellence a habit.™