

BS ISO 23317:2014



BSI Standards Publication

# Implants for surgery — In vitro evaluation for apatite-forming ability of implant materials

**bsi.**

...making excellence a habit.™

**National foreword**

This British Standard is the UK implementation of ISO 23317:2014. It supersedes BS ISO 23317:2012 which is withdrawn.

The UK participation in its preparation was entrusted to Technical Committee CH/150/1, Materials for surgical implants.

A list of organizations represented on this committee can be obtained on request to its secretary.

This publication does not purport to include all the necessary provisions of a contract. Users are responsible for its correct application.

© The British Standards Institution 2014.  
Published by BSI Standards Limited 2014

ISBN 978 0 580 84724 0  
ICS 11.040.40

**Compliance with a British Standard cannot confer immunity from legal obligations.**

This British Standard was published under the authority of the Standards Policy and Strategy Committee on 30 June 2014.

**Amendments/corrigenda issued since publication**

Date	Text affected
------	---------------

---

INTERNATIONAL  
STANDARD

**ISO**  
**23317**

Third edition  
2014-06-15

---

---

**Implants for surgery — In vitro  
evaluation for apatite-forming ability  
of implant materials**

*Implants chirurgicaux — Évaluation in vitro de la capacité de  
formation d'apatite des matériaux d'implants*



Reference number  
ISO 23317:2014(E)

© ISO 2014



**COPYRIGHT PROTECTED DOCUMENT**

© ISO 2014

All rights reserved. Unless otherwise specified, no part of this publication may be reproduced or utilized otherwise in any form or by any means, electronic or mechanical, including photocopying, or posting on the internet or an intranet, without prior written permission. Permission can be requested from either ISO at the address below or ISO's member body in the country of the requester.

ISO copyright office  
Case postale 56 • CH-1211 Geneva 20  
Tel. + 41 22 749 01 11  
Fax + 41 22 749 09 47  
E-mail [copyright@iso.org](mailto:copyright@iso.org)  
Web [www.iso.org](http://www.iso.org)

Published in Switzerland

# Contents

Page

<b>Foreword</b> .....	<b>iv</b>
<b>Introduction</b> .....	<b>v</b>
<b>1 Scope</b> .....	<b>1</b>
<b>2 Normative references</b> .....	<b>1</b>
<b>3 Terms and definitions</b> .....	<b>1</b>
<b>4 Apparatus</b> .....	<b>2</b>
<b>5 Test specimen</b> .....	<b>2</b>
5.1 Specimen configuration and size.....	2
5.2 Specimen preparation.....	2
<b>6 Simulated body fluid</b> .....	<b>3</b>
6.1 General.....	3
6.2 Reagents for SBF.....	3
6.3 Preparation of SBF.....	4
6.4 Confirmation of ion concentration of SBF.....	6
6.5 Preservation of SBF.....	6
<b>7 Procedure</b> .....	<b>6</b>
<b>8 Test report</b> .....	<b>8</b>
<b>Annex A (informative) Apparatus for preparing SBF</b> .....	<b>9</b>
<b>Annex B (informative) Preparation of standard glasses for evaluating apatite-forming ability</b> .....	<b>10</b>
<b>Bibliography</b> .....	<b>12</b>

## Foreword

ISO (the International Organization for Standardization) is a worldwide federation of national standards bodies (ISO member bodies). The work of preparing International Standards is normally carried out through ISO technical committees. Each member body interested in a subject for which a technical committee has been established has the right to be represented on that committee. International organizations, governmental and non-governmental, in liaison with ISO, also take part in the work. ISO collaborates closely with the International Electrotechnical Commission (IEC) on all matters of electrotechnical standardization.

The procedures used to develop this document and those intended for its further maintenance are described in the ISO/IEC Directives, Part 1. In particular the different approval criteria needed for the different types of ISO documents should be noted. This document was drafted in accordance with the editorial rules of the ISO/IEC Directives, Part 2 (see [www.iso.org/directives](http://www.iso.org/directives)).

Attention is drawn to the possibility that some of the elements of this document may be the subject of patent rights. ISO shall not be held responsible for identifying any or all such patent rights. Details of any patent rights identified during the development of the document will be in the Introduction and/or on the ISO list of patent declarations received (see [www.iso.org/patents](http://www.iso.org/patents)).

Any trade name used in this document is information given for the convenience of users and does not constitute an endorsement.

For an explanation on the meaning of ISO specific terms and expressions related to conformity assessment, as well as information about ISO's adherence to the WTO principles in the Technical Barriers to Trade (TBT) see the following URL: Foreword - Supplementary information

The committee responsible for this document is ISO/TC 150, *Implants for surgery*, Subcommittee SC 1, *Materials*.

This third edition cancels and replaces the second edition (ISO 23317:2012), which has been editorially revised.

## Introduction

It has been revealed that materials of various kinds bond to living bone through a layer of apatite. It has been shown that this apatite layer can be reproduced on their surfaces in an acellular and protein-free simulated body fluid (SBF) with ion concentrations nearly equal to those of human blood plasma, and that apatite thus formed is similar to the bone mineral in its composition and structure.

This evaluation of apatite-forming ability on implant material in SBF is useful for evaluating its *in vivo* bone-bonding ability preliminary to animal experiments. When a bioactive material is implanted in a living body, a thin layer rich in Ca and P forms on its surface. The material then connects to the living tissue through this apatite layer without a distinct boundary. It has been shown that this apatite layer can be reproduced on the surfaces of materials in SBF as well, and that apatite thus formed is similar to bone mineral in its composition and structure. As bioactivity increases, apatite forms on the material surface in a shorter time in proportion to this increase. The formation of apatite layers can be detected by thin film X-ray diffraction spectrometry and/or scanning electron microscopy.

The apatite formed in the SBF is, however, similar to bone apatite in the following points.

- Ca-deficient type apatite.
- Lower Ca/P atomic ratio than stoichiometric apatite.
- Containing some impurities such as  $Mg^{2+}$ ,  $Na^+$ ,  $Cl^-$ ,  $HCO_3^-$ .
- Low crystallinity.

NOTE 1 The material which forms apatite on its surface *in vivo* can bond to living bone, since this apatite is biologically active. Their *in vivo* apatite deposition can be reproduced on their surfaces even *in vitro* in SBF. For example, *in vivo* calcification on surfaces of Bioglass®<sup>1)</sup>, CaO-SiO<sub>2</sub> glasses, Na<sub>2</sub>O-CaO-SiO<sub>2</sub> glasses, Cerabone®<sup>2)</sup> A-W, Ceravital®<sup>3)</sup> -type glass-ceramic, sintered hydroxyapatite and alkali-heat-treated titanium metal, are correlated with *in vitro* calcification in SBF. However, this does not exclude the possibility that materials, which do not form apatite on their surfaces *in vivo*, bond to living bone. For example, it is reported that such resorbable materials as beta-tricalcium phosphate (Ca<sub>3</sub>(PO<sub>4</sub>)<sub>2</sub>) and calcium carbonate bond to living bone without forming an apatite layer on their surfaces.

NOTE 2 It has been reported that glasses with different compositions in the system Na<sub>2</sub>O-CaO-SiO<sub>2</sub> show a correlation between bone-forming ability of materials implanted into a bone defect of a rabbit and apatite-forming ability on its surface in SBF.

---

1) Trade names of products are an example of a suitable product available commercially. This information is given for the convenience of users of this document and does not constitute an endorsement by ISO of this product.

2) Trade names of products are an example of a suitable product available commercially. This information is given for the convenience of users of this document and does not constitute an endorsement by ISO of this product.

3) Trade names of products are an example of a suitable product available commercially. This information is given for the convenience of users of this document and does not constitute an endorsement by ISO of this product.





# Implants for surgery — In vitro evaluation for apatite-forming ability of implant materials

## 1 Scope

This International Standard specifies a method for detecting apatite formed on a surface of a material in simulated body fluid (SBF). It is applicable to implant surfaces intended to come into direct bone contact.

## 2 Normative references

The following documents, in whole or in part, are normatively referenced in this document and are indispensable for its application. For dated references, only the edition cited applies. For undated references, the latest edition of the referenced document (including any amendments) applies.

ISO 3696:1987, *Water for analytical laboratory use — Specification and test methods*

ISO 14630, *Non-active surgical implants — General requirements*

## 3 Terms and definitions

For the purposes of this document, the terms and definitions given in ISO 14630 and the following apply.

### 3.1

#### **apatite**

group of calcium-phosphates including bone mineral and the main inorganic constituent of bones and teeth similar to hydroxyapatite, which has the composition  $\text{Ca}_{10}(\text{PO}_4)_6(\text{OH})_2$

Note 1 to entry: Bone mineral also contains ions such as  $\text{CO}_3^{2-}$ ,  $\text{F}^-$ ,  $\text{Na}^+$  and  $\text{Mg}^{2+}$ .

### 3.2

#### **apatite-forming ability**

capability to develop apatite on the surface

### 3.3

#### **bioactivity**

property that elicits a specific biological response at the interface of the material, which results in the formation of a bond between tissue and material

### 3.4

#### **induction period**

time to detect apatite formation on a surface of a specimen after soaking the specimen in simulated body fluid

### 3.5

#### **simulated body fluid**

#### **SBF**

inorganic solution having a similar composition to human blood plasma without organic components

### 3.6

#### **standard glass for evaluating apatite-forming ability**

class of standard glasses with certain chemical compositions as shown in [Annex B](#) showing given apatite-forming abilities in SBF and when implanted in an animal body

### 3.7 thin film X-ray diffraction spectrometry TF-XRD

method for detecting minerals in a thin layer at the surface of a material from a diffraction pattern obtained by X-ray with small glancing angle against the surface of the sample

## 4 Apparatus

- 4.1 **Electric balance**, capable of measuring a mass with an accuracy of  $\pm 1$  mg.
- 4.2 **Water bath equipped with magnetic stirrer**, to maintain temperature of the solution within the range of  $(36,5 \pm 2)$  °C and an accuracy of  $\pm 0,2$  °C.
- 4.3 **pH meter**, capable of measuring the pH of a solution with an accuracy of  $\pm 0,01$ .
- 4.4 **Thermometer**, capable of measuring the temperature of a solution with an accuracy of  $\pm 0,1$ °C.
- 4.5 **Thin film X-ray diffraction spectrometer (TF-XRD)**, capable of detecting apatite formed in a thin layer at the surface of a material.
- 4.6 **Scanning electron microscope (SEM)**, capable of observing apatite grains and/or layers formed on a plain surface of a material with a magnification up to  $\times 10\ 000$ .

## 5 Test specimen

### 5.1 Specimen configuration and size

This International Standard allows specimens of any configuration and size derived from implant parts and devices to be used. However, a disc or rectangular plate specimen is highly recommended, because bioactivity of a material is evaluated by confirmation of apatite formed on the surface of the material using TF-XRD and/or SEM. Recommended specimen dimensions are shown in [Figure 1](#).

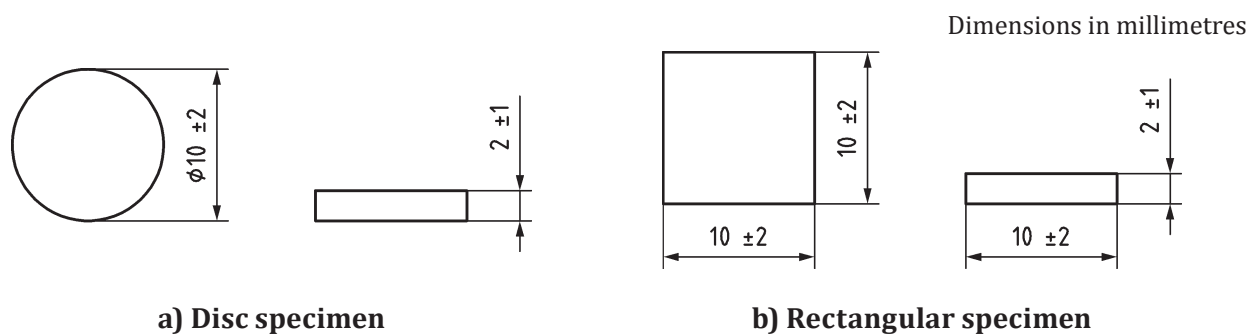

Figure 1 — Recommended specimen dimensions

### 5.2 Specimen preparation

#### 5.2.1 General

This International Standard allows several options for specimen preparation. The specimens should be machined, if necessary, to alter the configurations of original implants.

## 5.2.2 Basic machining procedure

In the case of a rectangular thin plate specimen as shown in [Figure 1 b](#), the following procedure shall be used. Specimens shall be ground using a diamond wheel of grit size between 120 and 400. Conditions such as depth of cut per pass, wheel speed and others depend on the ground material. Water soluble materials, such as bioactive standard glasses, shall be machined under non-aqueous conditions.

Where a customary machining procedure has been developed that is completely satisfactory for apatite-forming ability testing, this customary procedure can be used.

## 6 Simulated body fluid

### 6.1 General

Simulated body fluid (SBF) as defined in [Table 1](#) shall be used.

**Table 1 — Ion concentrations of SBF and human blood plasma**

Ion	Concentration ( $10^{-3}$ mol) in	
	SBF (pH 7,40)	Blood plasma (pH 7,2 to 7,4)
Na <sup>+</sup>	142,0	142,0
K <sup>+</sup>	5,0	5,0
Mg <sup>2+</sup>	1,5	1,5
Ca <sup>2+</sup>	2,5	2,5
Cl <sup>-</sup>	147,8	103,0
HCO <sub>3</sub> <sup>-</sup>	4,2	27,0
HPO <sub>4</sub> <sup>2-</sup>	1,0	1,0
SO <sub>4</sub> <sup>2-</sup>	0,5	0,5

NOTE 1 For SBF as defined in [Table 1](#), a correlation was observed between *in vivo* bone ingrowth and *in vitro* apatite-forming ability.

NOTE 2 Other kinds of SBFs have been proposed in the literature, some of which have shown a correlation between *in vivo* bone ingrowth and *in vitro* apatite-forming ability.

### 6.2 Reagents for SBF

For the preparation of SBF only reagents of the following recognized analytical grade chemicals and only water in accordance with ISO 3696:1987, grade 2, shall be used.

**6.2.1 Sodium chloride** (NaCl)

**6.2.2 Sodium hydrogen carbonate** (NaHCO<sub>3</sub>)

**6.2.3 Potassium chloride** (KCl)

**6.2.4 Di-potassium hydrogen phosphate trihydrate** (K<sub>2</sub>HPO<sub>4</sub> • 3H<sub>2</sub>O)

**6.2.5 Magnesium chloride hexahydrate** (MgCl<sub>2</sub> • 6H<sub>2</sub>O)

**6.2.6 Hydrochloric acid solution**,  $c(\text{HCl}) = 1 \text{ mol/l}$ .

**6.2.7 Calcium chloride (CaCl<sub>2</sub>) or calcium chloride dihydrate (CaCl<sub>2</sub> • 2H<sub>2</sub>O)**

**6.2.8 Sodium sulfate (Na<sub>2</sub>SO<sub>4</sub>)**

**6.2.9 Tris-hydroxymethyl aminomethane (TRIS): ((HOCH<sub>2</sub>)<sub>3</sub>CNH<sub>2</sub>)**

**6.3 Preparation of SBF**

**6.3.1 General**

Since SBF is supersaturated with respect to apatite, an inappropriate preparation method can lead to the homogeneous precipitation of apatite in the solution.

During its preparation the solution shall remain colourless, transparent and without deposit on the surface of the bottle. If any precipitation occurs, stop preparing SBF, abandon the solution and restart by washing the apparatus.

In [Table 2](#), the reagents for the preparation of 1 l of SBF are given in the required order of dissolution.

**Table 2 — Ion concentrations of SBF and human blood plasma**

Order	Reagent	Amount <sup>a</sup>	Container	Purity <sup>b</sup>	Formula weight
1	<a href="#">6.2.1</a>	8,035 g	weighing paper	99,5 %	58,443 0
2	<a href="#">6.2.2</a>	0,355 g	weighing paper	99,5 %	84,006 8
3	<a href="#">6.2.3</a>	0,225 g	weighing bottle	99,5 %	74,551 5
4	<a href="#">6.2.4</a>	0,231 g	weighing bottle	99,0 %	228,222 0
5	<a href="#">6.2.5</a>	0,311 g	weighing bottle	98,0 %	203,303 4
6	<a href="#">6.2.6</a>	39 ml	graduated cylinder	—	—
7	<a href="#">6.2.7</a> <sup>c</sup>	0,292 g	weighing bottle	95,0 %	110,984 8
8	<a href="#">6.2.8</a>	0,072 g	weighing bottle	99,0 %	142,042 8
9	<a href="#">6.2.9</a>	6,118 g	weighing paper	99,0 %	121,135 6
10	<a href="#">6.2.6</a>	0 ml to 5 ml	syringe dropper	—	—

<sup>a</sup> The amounts of the reagents are changed depending upon their purities.

<sup>b</sup> The purity given in this table is a typical purity for reagent available in most countries.

<sup>c</sup> If calcium chloride dihydrate (CaCl<sub>2</sub>) • 2H<sub>2</sub>O is used, attention shall be given to the different molar weight:

– amount 0,371 g

– purity 99,0 %

– formula weight 147,015 2

**6.3.2 Step 1**

Put 700 ml of ion-exchanged and distilled water, with a stirring bar, into a 1 litre plastic beaker. Set it in the water bath ([4.2](#)) on the magnetic stirrer and cover it with a watch glass or plastic wrap. Heat the water in the beaker to (36,5 ± 1,5)°C while stirring. [Annex A](#) shows an example of an apparatus for preparing the SBF.

### 6.3.3 Step 2

Dissolve the 1st to 8th reagents in the required order given in [Table 2](#) in the distilled water at  $(36,5 \pm 1,5)^{\circ}\text{C}$ , while considering the following.

- a) Glass containers should be avoided. A plastic container, with a smooth surface and without any scratches, is recommended, because apatite nucleation can be induced at the surface of a glass container or the edges of scratches.
- b) Dissolve a reagent only after the preceding one (if any) is completely dissolved.
- c) Dissolve the  $\text{CaCl}_2/\text{CaCl}_2 \cdot 2 \text{H}_2\text{O}$  little by little as the reagent has a great effect on the precipitation of apatite.
- d) Rinse the graduated cylinder with 1 mol/l HCl before measuring the volume of 1 mol/l HCl.
- e) Measure the hygroscopic reagents such as  $\text{K}_2\text{HPO}_4 \cdot 3 \text{H}_2\text{O}$ ,  $\text{MgCl}_2 \cdot 6 \text{H}_2\text{O}$ ,  $\text{CaCl}_2/\text{CaCl}_2 \cdot 2 \text{H}_2\text{O}$ , KCl,  $\text{Na}_2\text{SO}_4$  as quickly as possible.

### 6.3.4 Step 3

Insert the electrode of the pH meter ([4.3](#)) into the solution. Just before dissolving the TRIS, the pH of the solution should be  $2,0 \pm 1,0$ .

### 6.3.5 Step 4

Set the temperature of the solution at  $(36,5 \pm 1,5)^{\circ}\text{C}$ . If the amount of the solution is smaller than 0,9 l, add distilled water up to 0,9 l in total.

### 6.3.6 Step 5

With the solution temperature between  $(36,5 \pm 1,5)^{\circ}\text{C}$ , preferably  $(36,5 \pm 0,5)^{\circ}\text{C}$ , dissolve TRIS into the solution little by little, taking careful note of the pH change. After adding a small amount of TRIS, wait until the reagent is dissolved completely and the pH has become constant. Then add another small amount of TRIS.

It is recommended not to add a large amount of TRIS into the solution all at once, because the radical increase in local pH of the solution could lead to the precipitation of apatite. The following procedure is recommended: If the solution temperature is not within  $(36,5 \pm 0,5)^{\circ}\text{C}$ , add TRIS to raise the pH to  $7,3 \pm 0,05$ , then stop adding and wait for the solution temperature to reach  $(36,5 \pm 0,5)^{\circ}\text{C}$ . With the solution at  $(36,5 \pm 0,5)^{\circ}\text{C}$ , add more TRIS to raise the pH to under 7,45. The pH should not increase to over 7,45 at  $(36,5 \pm 0,5)^{\circ}\text{C}$ , taking account of the pH decrease with increasing solution temperature.

### 6.3.7 Step 6

Make sure that the temperature of the solution is maintained at  $(36,5 \pm 0,5)^{\circ}\text{C}$ . When the pH has risen to  $7,45 \pm 0,01$ , stop dissolving TRIS, then add HCl solution by syringe to lower the pH to  $7,42 \pm 0,01$ , taking care that the pH does not decrease below 7,40. After the pH has fallen to  $7,42 \pm 0,01$ , dissolve the remaining TRIS little by little until the pH has risen to  $\leq 7,45$ . If any TRIS remains, add the 1 mol/l -HCl and TRIS alternately into the solution. Repeat this process until the whole amount of TRIS is dissolved keeping the pH within the range of 7,42 to 7,45. After dissolving the whole amount of TRIS, adjust the temperature of the solution to  $(36,5 \pm 0,2)^{\circ}\text{C}$ . Adjust the pH of the solution by adding HCl solution little by little at a pH of  $7,42 \pm 0,01$  at  $(36,5^{\circ} \pm 0,2)^{\circ}\text{C}$  and then finally adjust it to 7,40 exactly at  $36,5^{\circ}\text{C}$  on condition that the rate of solution temperature increase or decrease is less than  $0,1^{\circ}\text{C}/\text{min}$ .

### 6.3.8 Step 7

Remove the electrode of the pH meter from the solution, rinse it with distilled water and add the washings to the solution.

### 6.3.9 Step 8

Pour the pH-adjusted solution from the beaker into a 1 l volumetric flask. Rinse the surface of the beaker with distilled water several times and add the washings to the flask. Fix the stirring bar with a magnet to prevent it from falling into the volumetric flask.

### 6.3.10 Step 9

Add the distilled water up to the marked line (it is not necessary to adjust exactly, because the volume becomes smaller after cooling). Put a lid on the flask and close it using a plastic film.

### 6.3.11 Step 10

After mixing the solution in the flask, keep it in the water bath to cool it down to 20°C.

### 6.3.12 Step 11

After the solution temperature has fallen to 20°C, add distilled water up to the marked line.

## 6.4 Confirmation of ion concentration of SBF

Prepared SBF shall have the ion concentrations given in [Table 1](#). In order to confirm the ion concentrations of the SBF, chemical analysis of the SBF is recommended because SBF is a metastable solution supersaturated with respect to apatite.

It is also recommended that the apatite-forming ability of standard glasses in the prepared SBF be examined. Chemical compositions of the standard glasses for evaluating apatite-forming ability are shown in [Figure B.1](#). When standard glasses A, B and C for evaluating apatite-forming ability are soaked in SBF, an apatite layer should be detected by TF-XRD pattern after soaking for about 12 h, 24 h and 120 h.

## 6.5 Preservation of SBF

Prepared SBF should be preserved in a plastic bottle with a lid put on tightly and kept at  $(7,5 \pm 2,5)^\circ\text{C}$  in a refrigerator. The SBF shall be used within 30 d of preparation.

It is recommended that the final product of SBF be sterilized by filtration to eliminate any dust particles and bacteria from the fluid, since dust can promote the heterogeneous nucleation of apatite and bacteria often phagocytose apatite formed in SBF. The sterilization should be carried out just after the preparation and/or just before evaluation for apatite-forming ability. For sterilization just after preparation (before preservation), the whole amount of as-prepared SBF is filtered by using a peristaltic pump through a sterile vented filter unit with a pore size of 0,22  $\mu\text{m}$  at the flow rate of 85 ml/min to 100 ml/min. For sterilization just before starting evaluation for apatite-forming ability, the SBF is filtered by using a syringe attached with a sterile vented filter unit with a pore size of 0,22  $\mu\text{m}$ . Either or both sterilization methods can be selected.

## 7 Procedure

**7.1** For dense materials, measure the specimen dimensions to an accuracy of  $\pm 0,1$  mm and calculate the surface area to an accuracy of 2 mm<sup>2</sup> for a thin plate.

**7.2** Calculate the volume of SBF that is used for testing using Formula (1):

$$v_s = 100mm \cdot S_a \quad (1)$$

where

$v_s$  is the volume of the SBF in mm<sup>3</sup>;

$S_a$  is the apparent surface area of the specimen in mm<sup>2</sup>.

For porous materials, the volume of SBF should be greater than the calculated  $v_s$ .

**7.3** Put the calculated volume of SBF into a plastic bottle with a cap or beaker. After heating the SBF to 36,5°C a specimen shall be placed in the SBF as shown in [Figure 2](#). The entire specimen shall be submerged in the SBF.

Pure, freshly prepared, dust-free SBF solution heated at 37°C for 4 weeks in a transparent bottle, even without any material for testing immersed in it, will precipitate apatite. If there happens to be a specimen immersed in that solution, those solution precipitates will then be deposited on the surface of the specimen. Therefore, it is recommended that the specimens be placed in the SBF as shown in [Figure 2 a\)](#) or [Figure 2 b\)](#). In case of placement as shown in [Figure 2 b\)](#), apatite formation should be examined on the lower surface of the specimen.

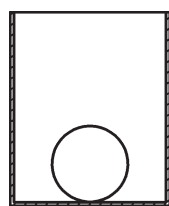

**a) Disc**



**b) Rectangular**

**Figure 2 — Examples of specimens in SBF**

**7.4** After soaking in the SBF at 36,5°C for different periods within four weeks, take out the specimen from the SBF and gently rinse it with distilled water.

A soaking time within four weeks is recommended.

The specimen shall then be dried in a desiccator without heating. A specimen, once taken out of SBF and dried, shall not be soaked again.

**NOTE** Bone bonding materials usually form apatite on their surfaces within four weeks.

**7.5** Examine the surface of a specimen by TF-XRD and/or SEM until apatite is detected.

It is recommended to perform the TF-XRD measurement in the range of 3° to 50° in 2 theta ( $\theta$ ) using CuK $\alpha$  ( $\lambda = 0,154\ 05\ \text{nm}$ ) radiation as the source at a rate of 2°/min and a 1° glancing angle against the incident beam on the specimen surface.

The dried specimen for SEM observation should be thinly metal-coated to induce electro conductivity. The SEM photos should be taken both at high magnifications (around  $\times 10\,000$ ) and low magnifications (around  $\times 1\,000$ ).

NOTE The TF-XRD measurement can clearly identify the apatite formation on the specimen. The SEM observation can observe the material formation on the specimen, but cannot identify whether apatite is formed or not. Therefore the SEM observation should be accompanied with the TF-XRD measurement. However, formed apatite grains and layers have characteristic features to be identified, and the apatite formation is sometimes estimated only on SEM.

## 8 Test report

The test report shall include the following information:

- a) all relevant material data including vintage, billet or component, specimen configurations and dimensions;
- b) specimen preparation procedure, including machining conditions for specimen surfaces;
- c) porosity of material as a percentage (optional);
- d) volume of SBF used in the measurement;
- e) soaking temperature of SBF ( $^{\circ}\text{C}$ );
- f) method of detecting the apatite on a specimen surface (TF-XRD and/or SEM);
- g) measurement conditions for TF-XRD with diffraction patterns and/or observation conditions for SEM with microphotographs showing the existence of apatite;
- h) presence or absence of apatite at each period; or estimated induction period (optional);
- i) number of specimens per condition;
- j) name of laboratory and date of the test;
- k) reference to this International Standard, i.e. ISO 23317:2014.



## Annex A (informative)

### Apparatus for preparing SBF

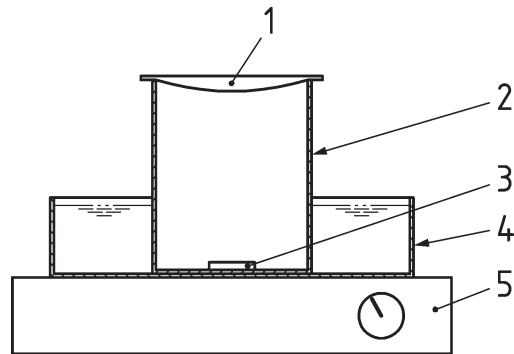

#### Key

- 1 watch glass
- 2 polyethylene beaker
- 3 magnetic bar
- 4 water bath
- 5 magnetic stirrer

Figure A.1 — Example of apparatus for preparing SBF

## Annex B (informative)

### Preparation of standard glasses for evaluating apatite-forming ability

The compositions of the standard glasses are given in [Table B.1](#). The fine grade reagents of  $\text{SiO}_2$ ,  $\text{Na}_2\text{CO}_3$  and  $\text{CaCO}_3$  should be used to prepare standard glasses. See [Figure B.1](#).

Prepare the reagents in the amounts listed in [Table B.2](#), taking into consideration the mass loss after burning at selected temperatures. (Alternatively, it is desirable to use the pre-heated reagents in order to eliminate a mass loss; e.g.  $\text{Na}_2\text{CO}_3$ ,  $\text{CaCO}_3$  and  $\text{SiO}_2$  are pre-heated at 1 000°C for 10 h, 600°C for 2 h and 550°C for 1 h, respectively.)

After being measured, reagents are gathered in an alumina mortar and mechanically well mixed by use of a pestle for 30 min.

Powders (for glasses A, B and C) in a platinum crucible are melted at 1 400°C for 1,5 h and then poured out on to a stainless steel plate with spacers 2 mm thick set on the plate. The glass is pressed immediately with another stainless steel plate and formed into a plate 2 mm thick. The glass plates are then moved to another stainless steel plate pre-heated to 500 °C. After annealing, the glasses are cut into specimens under a non-aqueous cooling medium, polished with No. 400 abrasive paper and finally washed in acetone in an ultrasonic bath.

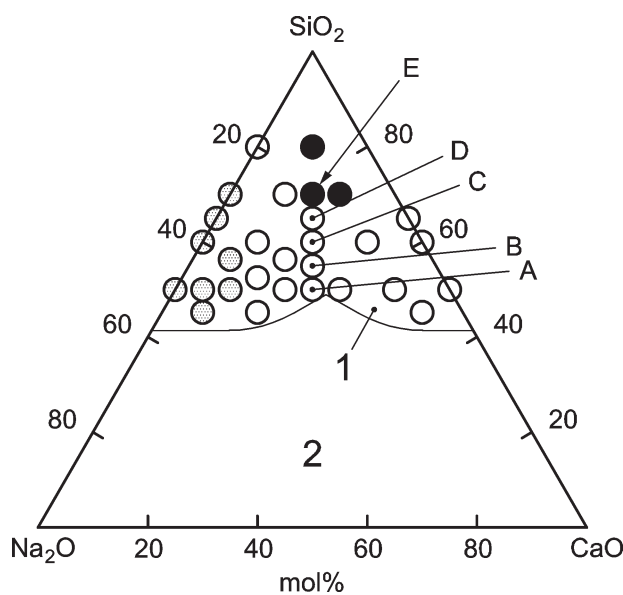

Key	
1	glass formation
2	no glass formation
○	apatite formation
●	no apatite formation
◐	dissolution

**Figure B.1 — Standard glasses in the  $\text{Na}_2\text{O}$ - $\text{CaO}$ - $\text{SiO}_2$  system and apatite-forming ability after soaking in SBF for 30 d**

**Table B.1 — Compositions of standard glasses in the Na<sub>2</sub>O-CaO-SiO<sub>2</sub> system**

Standard glass	Molar composition		
	Na <sub>2</sub> O	CaO	SiO <sub>2</sub>
Glass A	25	25	50
Glass B	22,5	22,5	55
Glass C	20	20	60

**Table B.2 — Mass fraction of reagents for preparing standard**

Standard glass	Mass fraction		
	Na <sub>2</sub> CO <sub>3</sub>	CaCO <sub>3</sub>	SiO <sub>2</sub>
Glass A	32,54	30,73	36,73
Glass B	30,08	28,41	41,51
Glass C	27,49	25,96	46,55

## Bibliography

- [1] CHO S.B., NAKANISHI K., KOKUBO T., SOGA N., OHTSUKI C., NAKAMURA T. et al. Dependence of Apatite Formation on Silica Gel on Its Structure: Effect of Heat Treatment. *J. Am. Ceram. Soc.* 1995, **78** (7) pp. 1769–1774
- [2] EBISAWA Y., KOKUBO T., OHURA K., YAMAMURO T. Bioactivity of CaO-SiO<sub>2</sub>-based glasses: In vitro evaluation. *J. Mater. Sci. Mater. Med.* 1990, **1** pp. 239–244
- [3] FILGUERIAS M.R., LATORRE G., HENCH L.L. Solution effects on the surface reaction of a bioactive glass. *J. Biomed. Mater. Res.* 1993, **27** pp. 445–453
- [4] FUJIBAYASHI S., NEO M., KIM H.-M., KOKUBO T., NAKAMURA T. A comparative study between in vivo bone ingrowth and in vitro apatite formation on Na<sub>2</sub>O-CaO-SiO<sub>2</sub> glasses. *Biomaterials.* 2003, **24** pp. 1349–1356
- [5] GIBSON I., HUANG J., BEST S, BONFIELD W. Enhanced in vitro cell activity and surface apatite layer formation on novel silicon-substituted hydroxyapatite, *Bioceramics*, edited by H. Ohgushi, G. Hastings and T. Yoshikawa, World Scientific Publishing, **12**, 1999
- [6] GIBSON I., HING K., REVELL P., SANTOS J., BEST S, BONFIELD W. Enhanced in vivo response to silicate-substituted hydroxyapatite, *Key Engineering Materials*, Trans Tech Publications, Switzerland, **218-220**, pp. 203-206, 2002
- [7] HENCH L.L. Bioceramics: from concept to clinic. *J. Am. Ceram. Soc.* 1991, **74** pp. 1487–1510
- [8] HOLAND W., VOGEL W., NAUMANN K, GUMMEL J. Interface reactions between machinable bioactive glass-ceramics and bone. *J. Biomed. Mater. Res.* 1985, **19** pp. 303–312
- [9] JUHASZ J.A., BEST S., BONFIELD W., KAWASHITA M., MIYATA N., KOKUBO T. et al. Apatite-forming ability of glass-ceramic apatite-wollastonite- polyethylene composites: effect of filler content. *J. Mater. Sci. Mater. Med.* 2003, **4** pp. 489–495
- [10] KIM H.-M., MIYAJI F, KOKUBO T, OHTSUKI C, NAKAMURA T. Bioactivity of Na<sub>2</sub>O-CaO-SiO<sub>2</sub> glasses. *J. Am. Ceram. Soc.* 1995, **78** (9) pp. 2405–2411
- [11] KIM H.-M., MIYAJI F, KOKUBO T, NAKAMURA T Preparation of bioactive Ti and its alloys via simple chemical surface treatment. *J. Biomed. Mater. Res.* 1996, **32** pp. 409–417
- [12] KIM H.-M., KISHIMOTO K., MIYAJI F., KOKUBO T., YAO T., SUETSUGU Y. et al. Composition and structure of the apatite formed on PET substrate in SBF modified with various ionic activity products. *J. Biomed. Mater. Res.* 1999, **46** pp. 228–235
- [13] KIM H.-M., KISHIMOTO K., MIYAJI F, KOKUBO T, YAO T, SUETSUGU Y. et al. Composition and structure of apatite formed on organic polymer in SBF with a high content of carbonate ion. *J. Mater. Sci. Mater. Med.* 2000, **11** pp. 421–426
- [14] KIM H.-M., HIMENO T, KAWASHITA M, KOKUBO T, NAKAMURA T. The mechanism of biomineralization of bone-like apatite on synthetic hydroxyapatite: an in vitro assessment. *J. R. Soc. Interface.* 2004, **1** pp. 17–22
- [15] KOKUBO T., KUSHITANI H.Y., EBISAWA Y., KITSUGI T., KOTANI S., OURA K, YAMAMURO T. Apatite formation on bioceramics in body environment, edited by H. Oonishi, H. Aoki and K. Sawai, Ishiyaku EuroAmerica, Tokyo, *Bioceramics*, **1**, pp. 157-162, 1989
- [16] KOKUBO T., KUSHITANI H., SAKKA S., KITSUGI T, YAMAMURO T. Solutions able to reproduce in vivo surface-structure changes in bioactive glass-ceramic A-W. *J. Biomed. Mater. Res.* 1990, **24** pp. 721–734

- [17] KOKUBO T., ITO S., HUANG Z.T., HAYASHI T., SAKKA S. KITSUGI, T. and YAMAMURO, T. Ca, P-rich layer formed on high-strength bioactive glass-ceramics A-W. *J. Biomed. Mater. Res.* 1990, **24** pp. 331–343
- [18] KOKUBO T., & TAKADAMA H. How useful is SBF in predicting in vivo bone bioactivity? *Biomaterials.* 2006, **27** pp. 2907–2915
- [19] HENCH L.L., & WILSON J. eds. *LEGEROS, R.Z. and LEGEROS, J.P. Dense Hydroxyapatite, An Introduction to Bioceramics.* World Sci, Singapore, 1993, pp. 139–80.
- [20] NEO M., KOTANI S., NAKAMURA T., YAMAMURO T., OHTSUKI C., KOKUBO T, BANDO Y. A. Comparative study of ultrastructures of the interfaces between four kinds of surface-active ceramic and bone. *J. Biomed. Mater. Res.* 1992, **26** pp. 1419–1432
- [21] NEO M., NAKAMURA T., OHTSUKI C., KOKUBO T, YAMAMURO T. Apatite formation on three kinds of bioactive material at an early stage in vivo: a comparative study by transmission electron microscopy. *J. Biomed. Mater. Res.* 1993, **27** pp. 999–1006
- [22] NISHIGUCHI S., FUJIBAYASHI S., KIM H.-M., KOKUBO T, NAKAMURA T. Biology of Alkali- and Heat-treated Titanium Implants. *J. Biomed. Mater. Res.* 2003, **67A** pp. 28–35
- [23] OHTSUKI C., KUSHITANI H., KOKUBO S., KOTANI T, YAMAMURO T. Apatite formation on the surface of Ceravital-type glass-ceramic in the body. *J. Biomed. Mater. Res.* 1991, **25** pp. 1363–1370
- [24] OHURA K., NAKAMURA T., YAMAMURO T., EBISAWA Y., KOKUBO T., KOTOURA Y. et al. Bioactivity of CaO·SiO<sub>2</sub> glasses added with various ions. *J. Mater. Sci. Mater. Med.* 1992, **3** pp. 95–100
- [25] OYANE A., KIM H.-M., FURUYA T., KOKUBO T., MIYAZAKI T, NAKAMURA T. Preparation and assessment of revised simulated body fluids. *J. Biomed. Mater. Res.* 2003, **65A** pp. 188–195
- [26] OYANE A., ONUMA K., ITO A., KIM H.-M, KOKUBO T, NAKAMURA T. Formation and growth of clusters in conventional and new kinds of simulated body fluids. *J. Biomed. Mater. Res.* 2003, **64A** (2) pp. 339–348
- [27] OYANE A., KAWASHITA M., NAKANISHI K., KOKUBO T., MINODA M., MIYAMOTO T, NAKAMURA T. Bonelike Apatite Formation on Ethylene-Vinyl Alcohol Copolymer Modified with Silane Coupling Agent and Calcium Silicate Solutions. *Biomaterials.* 2003, **24** pp. 1729–1735
- [28] TAKADAMA H., HASHIMOTO M., MIZUNO M, KOKUBO T. Round-Robin Test of SBF for In Vitro Measurement of Apatite-Forming Ability of Synthetic Materials. *Phosphorus Res. Bull.* 2005, **17** pp. 121–127





# British Standards Institution (BSI)

BSI is the national body responsible for preparing British Standards and other standards-related publications, information and services.

BSI is incorporated by Royal Charter. British Standards and other standardization products are published by BSI Standards Limited.

## About us

We bring together business, industry, government, consumers, innovators and others to shape their combined experience and expertise into standards-based solutions.

The knowledge embodied in our standards has been carefully assembled in a dependable format and refined through our open consultation process. Organizations of all sizes and across all sectors choose standards to help them achieve their goals.

## Information on standards

We can provide you with the knowledge that your organization needs to succeed. Find out more about British Standards by visiting our website at [bsigroup.com/standards](http://bsigroup.com/standards) or contacting our Customer Services team or Knowledge Centre.

## Buying standards

You can buy and download PDF versions of BSI publications, including British and adopted European and international standards, through our website at [bsigroup.com/shop](http://bsigroup.com/shop), where hard copies can also be purchased.

If you need international and foreign standards from other Standards Development Organizations, hard copies can be ordered from our Customer Services team.

## Subscriptions

Our range of subscription services are designed to make using standards easier for you. For further information on our subscription products go to [bsigroup.com/subscriptions](http://bsigroup.com/subscriptions).

With **British Standards Online (BSOL)** you'll have instant access to over 55,000 British and adopted European and international standards from your desktop. It's available 24/7 and is refreshed daily so you'll always be up to date.

You can keep in touch with standards developments and receive substantial discounts on the purchase price of standards, both in single copy and subscription format, by becoming a **BSI Subscribing Member**.

**PLUS** is an updating service exclusive to BSI Subscribing Members. You will automatically receive the latest hard copy of your standards when they're revised or replaced.

To find out more about becoming a BSI Subscribing Member and the benefits of membership, please visit [bsigroup.com/shop](http://bsigroup.com/shop).

With a **Multi-User Network Licence (MUNL)** you are able to host standards publications on your intranet. Licences can cover as few or as many users as you wish. With updates supplied as soon as they're available, you can be sure your documentation is current. For further information, email [bsmusales@bsigroup.com](mailto:bsmusales@bsigroup.com).

## BSI Group Headquarters

389 Chiswick High Road London W4 4AL UK

## Revisions

Our British Standards and other publications are updated by amendment or revision.

We continually improve the quality of our products and services to benefit your business. If you find an inaccuracy or ambiguity within a British Standard or other BSI publication please inform the Knowledge Centre.

## Copyright

All the data, software and documentation set out in all British Standards and other BSI publications are the property of and copyrighted by BSI, or some person or entity that owns copyright in the information used (such as the international standardization bodies) and has formally licensed such information to BSI for commercial publication and use. Except as permitted under the Copyright, Designs and Patents Act 1988 no extract may be reproduced, stored in a retrieval system or transmitted in any form or by any means – electronic, photocopying, recording or otherwise – without prior written permission from BSI. Details and advice can be obtained from the Copyright & Licensing Department.

## Useful Contacts:

### Customer Services

**Tel:** +44 845 086 9001

**Email (orders):** [orders@bsigroup.com](mailto:orders@bsigroup.com)

**Email (enquiries):** [cservices@bsigroup.com](mailto:cservices@bsigroup.com)

### Subscriptions

**Tel:** +44 845 086 9001

**Email:** [subscriptions@bsigroup.com](mailto:subscriptions@bsigroup.com)

### Knowledge Centre

**Tel:** +44 20 8996 7004

**Email:** [knowledgecentre@bsigroup.com](mailto:knowledgecentre@bsigroup.com)

### Copyright & Licensing

**Tel:** +44 20 8996 7070

**Email:** [copyright@bsigroup.com](mailto:copyright@bsigroup.com)



...making excellence a habit.™