



BSI Standards Publication

Fine ceramics (advanced ceramics, advanced technical ceramics) — Determination of bulk density of ceramic powders

Part 2: Untapped density

National foreword

This British Standard is the UK implementation of ISO 23145-2:2012.

The UK participation in its preparation was entrusted to Technical Committee RPI/13, Advanced technical ceramics.

A list of organizations represented on this committee can be obtained on request to its secretary.

This publication does not purport to include all the necessary provisions of a contract. Users are responsible for its correct application.

© The British Standards Institution 2012. Published by BSI Standards Limited 2012

ISBN 978 0 580 69637 4

ICS 81.060.30

Compliance with a British Standard cannot confer immunity from legal obligations.

This British Standard was published under the authority of the Standards Policy and Strategy Committee on 30 June 2012.

Amendments issued since publication

Date	Text affected
------	---------------

**Fine ceramics (advanced ceramics,
advanced technical ceramics) —
Determination of bulk density of
ceramic powders —**

**Part 2:
Untapped density**

*Céramiques techniques — Détermination de la masse volumique des
poudres céramiques —*

Partie 2: Masse volumique sans tassement





COPYRIGHT PROTECTED DOCUMENT

© ISO 2012

All rights reserved. Unless otherwise specified, no part of this publication may be reproduced or utilized in any form or by any means, electronic or mechanical, including photocopying and microfilm, without permission in writing from either ISO at the address below or ISO's member body in the country of the requester.

ISO copyright office
Case postale 56 • CH-1211 Geneva 20
Tel. + 41 22 749 01 11
Fax + 41 22 749 09 47
E-mail copyright@iso.org
Web www.iso.org

Published in Switzerland

Contents

Page

Foreword	iv
1 Scope	1
2 Normative references	1
3 Principle	1
4 Apparatus	1
5 Sampling	4
6 Procedure	5
7 Calculation	5
8 Test report	5
Bibliography	7

Foreword

ISO (the International Organization for Standardization) is a worldwide federation of national standards bodies (ISO member bodies). The work of preparing International Standards is normally carried out through ISO technical committees. Each member body interested in a subject for which a technical committee has been established has the right to be represented on that committee. International organizations, governmental and non-governmental, in liaison with ISO, also take part in the work. ISO collaborates closely with the International Electrotechnical Commission (IEC) on all matters of electrotechnical standardization.

International Standards are drafted in accordance with the rules given in the ISO/IEC Directives, Part 2.

The main task of technical committees is to prepare International Standards. Draft International Standards adopted by the technical committees are circulated to the member bodies for voting. Publication as an International Standard requires approval by at least 75 % of the member bodies casting a vote.

Attention is drawn to the possibility that some of the elements of this document may be the subject of patent rights. ISO shall not be held responsible for identifying any or all such patent rights.

ISO 23145-2 was prepared by Technical Committee ISO/TC 206, *Fine ceramics*.

ISO 23145 consists of the following parts, under the general title *Fine ceramics (advanced ceramics, advanced technical ceramics)* — *Determination of bulk density of ceramic powders*:

- *Part 1: Tap density*
- *Part 2: Untapped density*

Fine ceramics (advanced ceramics, advanced technical ceramics) — Determination of bulk density of ceramic powders —

Part 2: Untapped density

1 Scope

This part of ISO 23145 specifies the test method to determine the untapped density of granulated or ungranulated ceramic powders by a constant-volume measuring method.

2 Normative references

The following referenced documents are indispensable for the application of this document. For dated references, only the edition cited applies. For undated references, the latest edition of the referenced document (including any amendments) applies.

ISO 565:1990, *Test sieves — Metal wire cloth, perforated metal plate and electroformed sheet — Nominal sizes of openings*

ISO 80000-1:2009, *Quantities and units — Part 1: General*

ISO/IEC 17025:2005, *General requirements for the competence of testing and calibration laboratories*

3 Principle

The mass of a known volume of the powder is determined after allowing it to fall freely into a stationary container, avoiding vibration. The mass of the powder divided by its volume after the test gives its untapped density.

4 Apparatus

4.1 Funnel (Figure 1), of stainless steel, with an orifice of diameter 2,5 mm and the other with an orifice of diameter 5,0 mm. The funnel shall be made of a non-magnetic, corrosion-resistant metallic material such as stainless steel (for example SUS 304) having sufficient wall thickness and hardness to withstand distortion and excessive wear.

4.2 Cylindrical container (Figure 2), of stainless steel, with a volume of 100 cm³ and a diameter-to-height ratio of approximately 1.

4.3 Sieve, as specified in ISO 565, with an aperture size of 0,71 mm.

4.4 Balance, with a precision of 0,1 g or 0,01 g.

A balance with a precision of 0,01 g should be used for very fluffy powders such as aerosil (fumed silica).

4.5 Straight edge (Figure 3), to remove the cone of surplus powder by gently drawing it.

4.6 Stand and horizontal vibration-free base. A stand to support the funnel concentric with the cylindrical container so that the bottom of the funnel orifice is approximately 50 mm above the top of the cylindrical container when the apparatus is assembled as shown in Figure 4.

Dimensions in millimetres

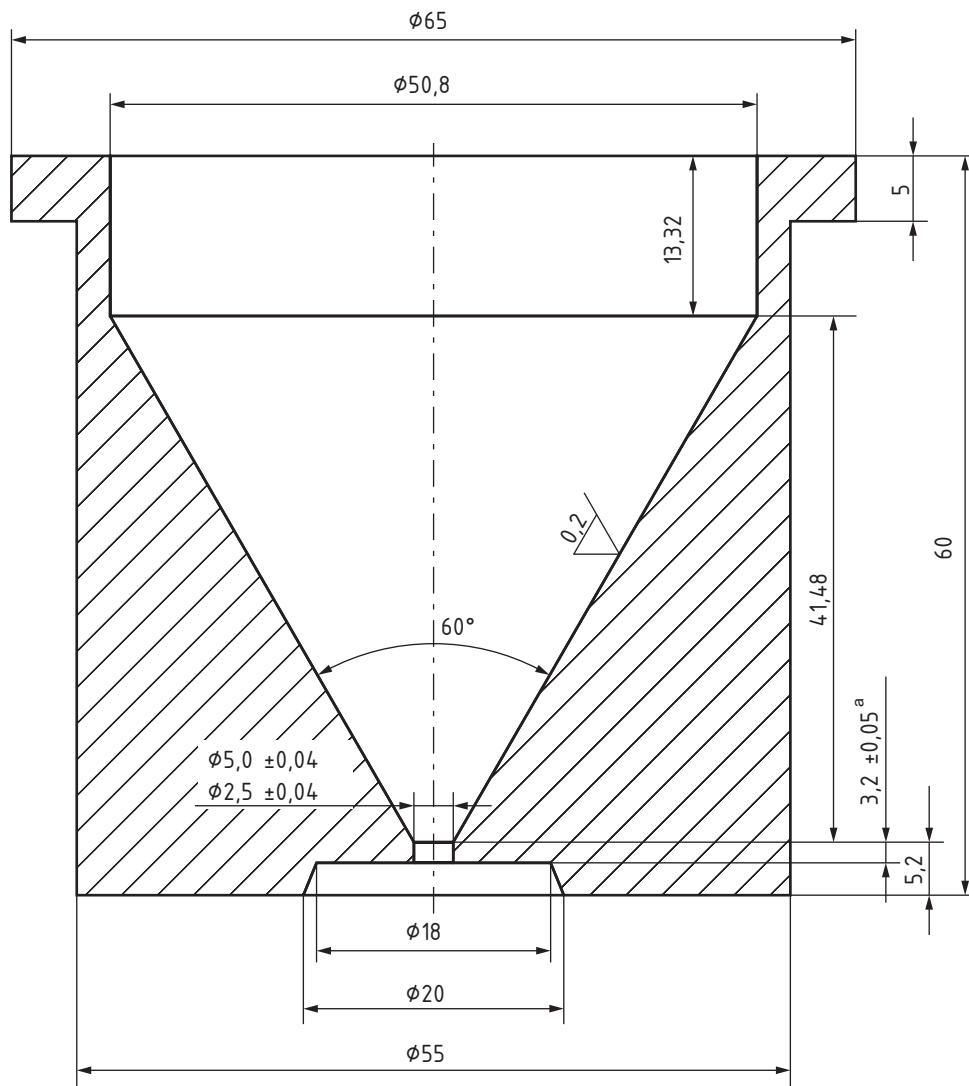

^a Or $6,4 \pm 0,05$ for 5,0 mm diameter.

Figure 1 — Example of a funnel

Dimensions in millimetres

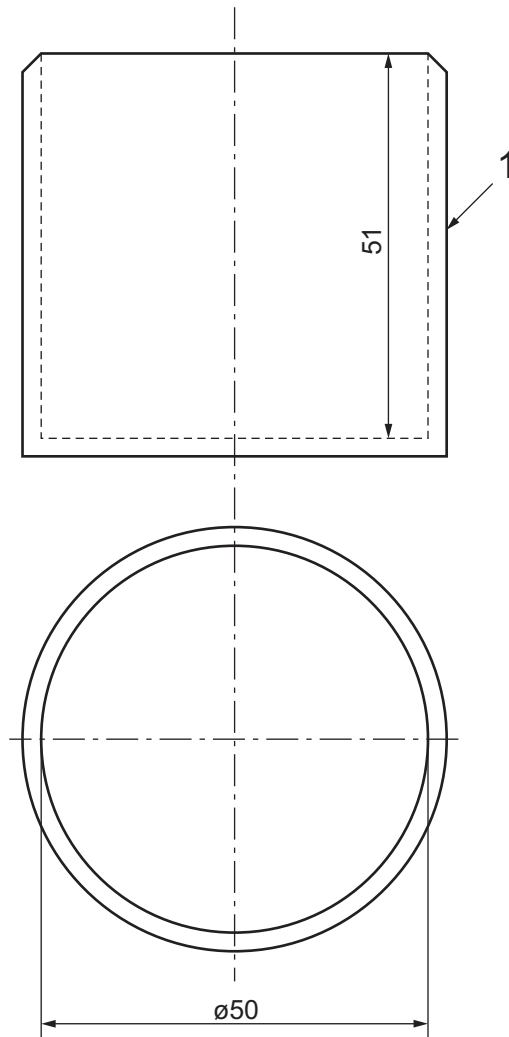

Key

- 1 cylindrical container

Figure 2 — Example of a cylindrical container

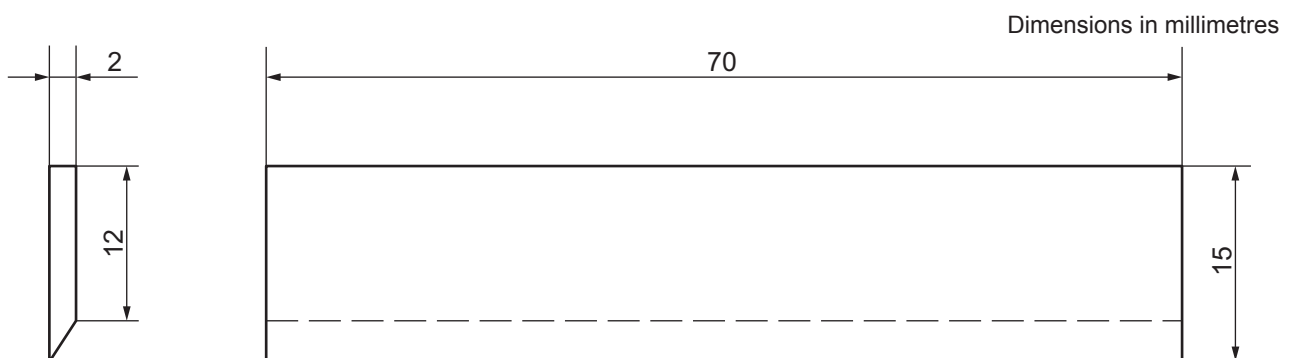
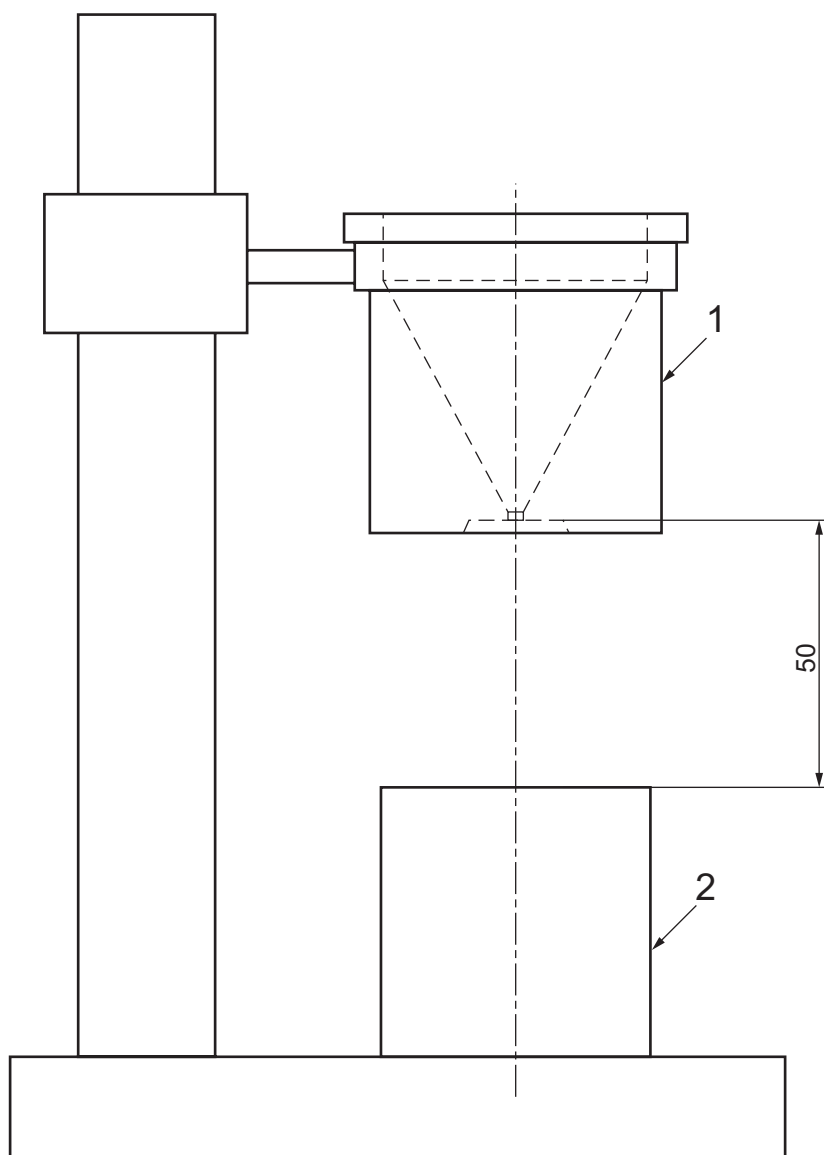

Figure 3 — Example of a straight edge

Dimensions in millimetres



Key

- 1 funnel
- 2 cylindrical container

Figure 4 — Example of apparatus for untapped density

5 Sampling

5.1 In general, the powder should be tested in the as-received condition. In certain instances the powder may be dried. If the powder is required to be dried, it should be dried at $(110 \pm 5) ^\circ\text{C}$ for at least 1 h and cooled to room temperature in a desiccator. If the powder contains volatile substances, it shall not be dried.

NOTE If the powder must be dried, it is preferred that the powder be dried until the rate of mass loss is less than 0,1 % (by mass) per 30 min.

5.2 Should there be any treatment (e.g. drying) of the powder before measurement, it shall be recorded in the test report.

5.3 The test shall be carried out on three test portions.

6 Procedure

6.1 Weigh the empty cylindrical container (m_0).

6.2 Pass the ceramic powder through the sieve.

6.3 Fill the funnel having the 2,5 mm diameter orifice with the powder and allow the powder to flow through the orifice into the cylindrical container until it is completely filled and the powder overflows its periphery.

NOTE 1 If the powder does not flow through the 2,5 mm diameter orifice, use the funnel having the 5,0 mm diameter orifice.

NOTE 2 If the powder does not flow through the 5,0 mm diameter orifice, it is allowed to poke the powder within the funnel by a thin wire to stimulate flowing.

6.4 Remove the cone of surplus powder by gently drawing a straight edge across the top rim of the cylindrical container without compressing it and take care not to jar or vibrate the cylindrical container.

6.5 After levelling the powder, tap the cylindrical container lightly to settle the powder in order to avoid spilling it during transport.

6.6 Weigh the cylindrical container and its contents (m_1).

6.7 Repeat the procedure in 6.1 to 6.6 with two additional portions and average the results.

7 Calculation

Calculate the untapped density from the mass of the powder divided by the volume of the cylindrical container and round the result to 0,001 g/cm³ or 1 kg/m³ in accordance with ISO 80000-1.

$$p_t = \frac{m_1 - m_0}{V} \quad (1)$$

where

p_t is the untapped density, in grams per cubic centimetre, of the ceramic powder;

m_0 is the mass, in grams, of the empty cylindrical container;

m_1 is the mass, in grams, of the cylindrical container full of the powder;

V is the volume, in cubic centimetres, of the cylindrical container (100 cm³)

8 Test report

The test report shall be in accordance with the reporting provisions of ISO/IEC 17025 and shall contain the following information:

- a) the name of the testing establishment;
- b) date of the test, report identification and number, operator, signatory;
- c) temperature and relative humidity in the laboratory
- d) a reference to this part of ISO 23145;

- e) all details for identification of the test sample (material type, manufacturer, batch or code number);
- f) all operations not specified by this part of ISO 23145, or regarded as optional (e.g. any pretreatment of the powder such as drying);
- g) the result obtained: untapped density (kg/m^3 or g/cm^3);
- h) details of any occurrence which may have affected the result (e.g. blockage of orifice, powder poking by a wire, etc.);
- i) comments about the test or test results.

Bibliography

- [1] EN 725-9, *Advanced technical ceramics — Method of test for ceramic powders — Part 9. Determination of un-tapped bulk density*
- [2] JIS R 1628, *Test methods for bulk density of fine ceramic powder*
- [3] JIS R 1639-2, *Test methods of properties of fine ceramic granules — Part 2: Bulk density*
- [4] ISO 3923-1, *Metallic powders — Determination of apparent density — Part 1: Funnel method*
- [5] ASTM B212, *Standard Test Method for Apparent Density of Free-Flowing Metal Powders Using the Hall Flowmeter Funnel*
- [6] ISO 690-2, *Information and documentation — Bibliographic references — Part 2: Electronic documents or parts thereof*

British Standards Institution (BSI)

BSI is the national body responsible for preparing British Standards and other standards-related publications, information and services.

BSI is incorporated by Royal Charter. British Standards and other standardization products are published by BSI Standards Limited.

About us

We bring together business, industry, government, consumers, innovators and others to shape their combined experience and expertise into standards-based solutions.

The knowledge embodied in our standards has been carefully assembled in a dependable format and refined through our open consultation process. Organizations of all sizes and across all sectors choose standards to help them achieve their goals.

Information on standards

We can provide you with the knowledge that your organization needs to succeed. Find out more about British Standards by visiting our website at bsigroup.com/standards or contacting our Customer Services team or Knowledge Centre.

Buying standards

You can buy and download PDF versions of BSI publications, including British and adopted European and international standards, through our website at bsigroup.com/shop, where hard copies can also be purchased.

If you need international and foreign standards from other Standards Development Organizations, hard copies can be ordered from our Customer Services team.

Subscriptions

Our range of subscription services are designed to make using standards easier for you. For further information on our subscription products go to bsigroup.com/subscriptions.

With **British Standards Online (BSOL)** you'll have instant access to over 55,000 British and adopted European and international standards from your desktop. It's available 24/7 and is refreshed daily so you'll always be up to date.

You can keep in touch with standards developments and receive substantial discounts on the purchase price of standards, both in single copy and subscription format, by becoming a **BSI Subscribing Member**.

PLUS is an updating service exclusive to BSI Subscribing Members. You will automatically receive the latest hard copy of your standards when they're revised or replaced.

To find out more about becoming a BSI Subscribing Member and the benefits of membership, please visit bsigroup.com/shop.

With a **Multi-User Network Licence (MUNL)** you are able to host standards publications on your intranet. Licences can cover as few or as many users as you wish. With updates supplied as soon as they're available, you can be sure your documentation is current. For further information, email bsmusales@bsigroup.com.

BSI Group Headquarters

389 Chiswick High Road London W4 4AL UK

Revisions

Our British Standards and other publications are updated by amendment or revision.

We continually improve the quality of our products and services to benefit your business. If you find an inaccuracy or ambiguity within a British Standard or other BSI publication please inform the Knowledge Centre.

Copyright

All the data, software and documentation set out in all British Standards and other BSI publications are the property of and copyrighted by BSI, or some person or entity that owns copyright in the information used (such as the international standardization bodies) and has formally licensed such information to BSI for commercial publication and use. Except as permitted under the Copyright, Designs and Patents Act 1988 no extract may be reproduced, stored in a retrieval system or transmitted in any form or by any means – electronic, photocopying, recording or otherwise – without prior written permission from BSI. Details and advice can be obtained from the Copyright & Licensing Department.

Useful Contacts:

Customer Services

Tel: +44 845 086 9001

Email (orders): orders@bsigroup.com

Email (enquiries): cservices@bsigroup.com

Subscriptions

Tel: +44 845 086 9001

Email: subscriptions@bsigroup.com

Knowledge Centre

Tel: +44 20 8996 7004

Email: knowledgecentre@bsigroup.com

Copyright & Licensing

Tel: +44 20 8996 7070

Email: copyright@bsigroup.com



...making excellence a habit.™