

BS ISO 22839:2013



BSI Standards Publication

Intelligent transport systems — Forward vehicle collision mitigation systems — Operation, performance, and verification requirements

NO COPYING WITHOUT BSI PERMISSION EXCEPT AS PERMITTED BY COPYRIGHT LAW

raising standards worldwide™



National foreword

This British Standard is the UK implementation of ISO 22839:2013.

The UK participation in its preparation was entrusted to Technical Committee EPL/278, Road transport informatics.

A list of organizations represented on this committee can be obtained on request to its secretary.

This publication does not purport to include all the necessary provisions of a contract. Users are responsible for its correct application.

© The British Standards Institution 2013. Published by BSI Standards Limited 2013

ISBN 978 0 580 71323 1

ICS 35.240.60; 43.040.99

Compliance with a British Standard cannot confer immunity from legal obligations.

This British Standard was published under the authority of the Standards Policy and Strategy Committee on 30 June 2013.

Amendments issued since publication

| Date | Text affected |
|------|---------------|
|------|---------------|

**Intelligent transport systems — Forward
vehicle collision mitigation systems —
Operation, performance, and verification
requirements**

*Systemes intelligents de transport — Systemes d'attenuation de
collision de vehicule frontale — Exigences de fonctionnement, de
performance et de verification*





COPYRIGHT PROTECTED DOCUMENT

© ISO 2013

All rights reserved. Unless otherwise specified, no part of this publication may be reproduced or utilized otherwise in any form or by any means, electronic or mechanical, including photocopying, or posting on the internet or an intranet, without prior written permission. Permission can be requested from either ISO at the address below or ISO's member body in the country of the requester.

ISO copyright office
Case postale 56 • CH-1211 Geneva 20
Tel. + 41 22 749 01 11
Fax + 41 22 749 09 47
E-mail copyright@iso.org
Web www.iso.org

Published in Switzerland

Contents

Page

| | |
|---|-----------|
| Foreword | v |
| Introduction..... | vi |
| 1 Scope | 1 |
| 2 Normative references | 1 |
| 3 Terms and definitions | 1 |
| 4 Symbols (and abbreviated terms) | 6 |
| 5 Classifications | 7 |
| 5.1 System classification by curve radius capability | 7 |
| 5.2 Classification by countermeasure types included | 7 |
| 5.2.1 Collision Warning (CW) countermeasure | 7 |
| 5.2.2 Speed Reduction Braking (SRB) countermeasure | 7 |
| 5.2.3 Mitigation Braking (MB) Countermeasure | 8 |
| 5.2.4 Combining countermeasures | 8 |
| 6 Requirements | 8 |
| 6.1 Minimum enabling capabilities | 8 |
| 6.1.1 Light vehicle necessary functions | 8 |
| 6.1.2 Heavy vehicle necessary functions | 9 |
| 6.2 Operating model — State Transition Diagram | 9 |
| 6.2.1 State functional descriptions | 10 |
| 6.3 Performance requirements | 11 |
| 6.3.1 Target vehicle types | 11 |
| 6.3.2 Collision types | 11 |
| 6.3.3 Operating speed | 11 |
| 6.3.4 Target vehicle detection area | 13 |
| 6.3.5 Target discrimination | 14 |
| 6.3.6 Countermeasure requirements | 15 |
| 6.3.7 Driver controls and human interface | 18 |
| 7 Validation methods | 19 |
| 7.1 Test target specification | 19 |
| 7.1.1 Detectability specifications | 19 |
| 7.1.2 Test target physical constraints | 20 |
| 7.2 Environmental conditions | 20 |
| 7.2.1 Driving surface | 20 |
| 7.2.2 Lighting conditions | 20 |
| 7.2.3 Ambient air temperature | 20 |
| 7.2.4 Horizontal visibility | 21 |
| 7.3 Test method for detection zone | 21 |
| 7.4 Test method for functional ability | 21 |
| 7.5 Test method for target discrimination ability | 22 |
| 7.5.1 Longitudinal discrimination test | 22 |
| 7.5.2 Straight road lateral discrimination test | 23 |
| 7.5.3 Straight road lateral offset discrimination test | 23 |
| 7.5.4 Curved road lateral target discrimination test | 24 |
| 7.5.5 Overhead discrimination test | 24 |
| Annex A (informative)..... | 26 |
| A.1 Mitigation effectiveness and the potential for collision avoidance | 26 |
| A.2 Minimum relative speed capability and assumed sensor capability | 26 |
| A.3 Operating velocity range minimum upper bound | 28 |

| | | |
|--------------|---|-----------|
| A.4 | Reference data on global speed distribution of rear-end collisions | 28 |
| A.4.1 | USA | 29 |
| A.4.2 | Canada | 29 |
| A.4.3 | Japan..... | 30 |
| A.5 | Vehicle classifications | 31 |
| A.6 | Derivation of ETTC..... | 31 |
| A.7 | Relationship between ACC (ISO 15622), FSRA (ISO 22179), and FVCMS..... | 31 |
| | Bibliography..... | 33 |

Foreword

ISO (the International Organization for Standardization) is a worldwide federation of national standards bodies (ISO member bodies). The work of preparing International Standards is normally carried out through ISO technical committees. Each member body interested in a subject for which a technical committee has been established has the right to be represented on that committee. International organizations, governmental and non-governmental, in liaison with ISO, also take part in the work. ISO collaborates closely with the International Electrotechnical Commission (IEC) on all matters of electrotechnical standardization.

The procedures used to develop this document and those intended for its further maintenance are described in the ISO/IEC Directives, Part 1. In particular the different approval criteria needed for the different types of ISO documents should be noted. This document was drafted in accordance with the editorial rules of the ISO/IEC Directives, Part 2. www.iso.org/directives

Attention is drawn to the possibility that some of the elements of this document may be the subject of patent rights. ISO shall not be held responsible for identifying any or all such patent rights. Details of any patent rights identified during the development of the document will be in the Introduction and/or on the ISO list of patent declarations received. www.iso.org/patents

Any trade name used in this document is information given for the convenience of users and does not constitute an endorsement.

The committee responsible for this document is ISO/TC 204, *Intelligent transport systems*.

Introduction

Forward Vehicle Collision Mitigation Systems (FVCMS) reduce the severity of forward vehicle collisions that cannot be avoided, and may reduce the likelihood of collision with forward vehicles. FVCMS require information about range to forward vehicles, motion of forward vehicles, motion of the subject vehicle, driver commands and driver actions. FVCMS detect vehicles ahead, determine if detected vehicles represent a hazardous condition, and warn the driver if a hazard exists. They estimate if the driver has an adequate opportunity to respond to the hazard. If there is inadequate time available for the driver to respond, and if appropriate criteria are met, FVCMS determine that a collision is imminent. Based upon this assessment, the FVCMS will activate vehicle brakes to mitigate collision severity.

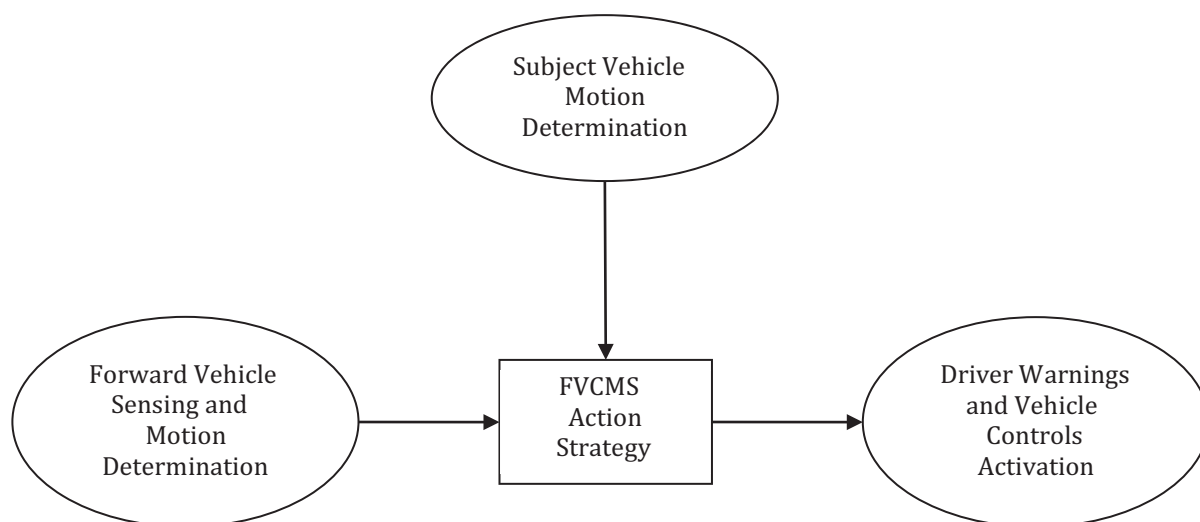

Figure 1 — Forward Vehicle Collision Mitigation Systems (FVCMS) Functional Elements

System designers and other users of this International Standard may apply it to stand-alone FVCMS or to the integration of the FVCMS functions into other driving assistance and support systems.

Intelligent transport systems — Forward vehicle collision mitigation systems — Operation, performance, and verification requirements

1 Scope

This International Standard specifies the concept of operation, minimum functionality, system requirements, system interfaces, and test methods for Forward Vehicle Collision Mitigation Systems (FVCMS). It specifies the behaviours that are required for FVCMS, and the system test criteria necessary to verify that a given implementation meets the requirements of this International Standard. Implementation choices are left to system designers, wherever possible.

FVCMS mitigate rear-end collisions. By reducing the collision energy, FVCMS reduce the degree of property damage, personal injury, or the likelihood of fatality. They supplement crashworthiness systems such as airbags, seatbelts and other energy-absorbing systems by reducing the impact energy that must be isolated from the occupants. By automatically activating collision mitigation braking after a Collision Warning occurs, FVCMS assist in slowing the vehicle when a collision is likely. While collision avoidance is not required, this International Standard permits collision avoidance to be attempted by a system that conforms to FVCMS. Responsibility for the safe operation of the vehicle remains with the driver.

With the exceptions of single-track vehicles and trucks with dual or triple trailers, FVCMS are for use on road vehicles intended for public and non-public roadways. These systems are not intended for off-road use.

2 Normative references

The following documents, in whole or in part, are normatively referenced in this document and are indispensable for its application. For dated references, only the edition cited applies. For undated references, the latest edition of the referenced document (including any amendments) applies.

ISO 15622, *Intelligent transport systems — Adaptive Cruise Control systems — Performance requirements and test procedures*

ISO 15623, *Transport information and control systems — Forward vehicle collision warning systems — Performance requirements and test procedures*

ISO 22179, *Intelligent transport systems — Full speed range adaptive cruise control (FSRA) systems — Performance requirements and test procedures*

3 Terms and definitions

For the purposes of this document, the following terms and definitions apply.

3.1

adaptive cruise control

ACC

enhancement to conventional cruise control systems which allows the subject vehicle to follow a forward vehicle at an appropriate distance by controlling the engine and/or power train and optionally the brake

Note 1 to entry: See ISO 15622.

**3.2
adjacent lane**

lane of travel sharing one lane boundary with the lane in which the subject vehicle is traveling, and having the same direction of travel as the subject vehicle

**3.3
articulated vehicle**

any road vehicle with more than two wheels that is configured for normal road use with at least two segments, and for which each adjacent pair of segments is connected by a joint, and for which propulsion is provided by at least one segment

**3.4
brakes**

components which generate the forces opposing the movement of the vehicle

EXAMPLES Friction brakes (when the forces are generated by friction between two parts of the vehicle moving relative to one another); electrical brakes (when the forces are generated by electro-magnetic action between two parts of the vehicle moving relatively but not in contact with one another); fluid brakes (when the forces are generated by the action of a fluid situated between two parts of the vehicle moving relatively to one another); or engine brakes (when the forces are derived from an artificial increase in the braking action, transmitted to the wheels, of the engine).

**3.5
braking distance**

distance the vehicle will travel from the point where its brakes are applied to where it comes to a complete stop

**3.6
clearance**

$x_c(t)$
distance $x_c(t)$ from the target vehicle trailing surface to the subject vehicle leading surface

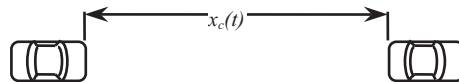

**3.7
Collision Warning
CW**

information that FVCMS gives to the driver to indicate the need for urgent action to avoid a collision

Note 1 to entry: This warning is issued to warn the driver of the need to perform an emergency manoeuvre in order to avoid a collision.

**3.8
conventional cruise control**

system capable of maintaining the speed of a vehicle as set by the driver

**3.9
countermeasure action point
CAP**

value of pre-collision urgency parameter (PUP), relative to an expected collision, for which FVCMS initiates a countermeasure

**3.10
driver disengage**

driver initiated transition from FVCMS Active or Inactive state to FVCMS Off state

3.11
enhanced time to collision
ETTC

time that it will take a subject vehicle to collide with the target vehicle assuming the relative acceleration between the subject vehicle (SV) and target vehicle (TV) remains constant, as given in the following equation:

$$ETTC = \frac{\left[-(v_{TV} - v_{SV}) - \sqrt{(v_{TV} - v_{SV})^2 - 2 * (a_{TV} - a_{SV}) * x_c} \right]}{(a_{TV} - a_{SV})}$$

3.12
forward adjacent vehicle

vehicle not in the path of the subject vehicle (SV), and entirely ahead of a line touching the SV front bumper at only one point and perpendicular to the longitudinal axis of the SV

3.13
forward ranging sensor

component which detects objects in at least part of the region entirely ahead of the front bumper

3.14
forward vehicle
FV

vehicle in front of the subject vehicle (SV), which is moving in the same direction and traveling in the same path, or which is oriented in the same direction if it is not moving

3.15
forward vehicle collision

collision between the subject vehicle (SV) and a forward vehicle (FV)

3.16
Forward Vehicle Collision Mitigation Systems
FVCMS

vehicle systems meeting the requirements of ISO 22839 that assess the likelihood of a collision between the front of the subject vehicle (SV) and the rear of a target vehicle (TV), and when such a collision is very likely, activates the brakes automatically to reduce the relative speed at which the SV and TV may collide

3.17
Forward Vehicle Collision Warning Systems
FVCWS

systems capable of warning the driver of a potential collision with another vehicle in the forward path of the subject vehicle, excluding conditions where the subject and forward vehicle are not in the same direction of travel

Note 1 to entry: See ISO 15623.

3.18
heavy vehicle

any single vehicle or combination of vehicles defined as Category 1-2 or Category 2 in the United Nations Economic and Social Council World Forum for Harmonization of Vehicle Regulations (WP.29) TRANS/WP.29/1045

3.19
jerk

third derivative with respect to time of the position of an object, equivalently the rate of change of the acceleration of an object, considered a measure of the harshness of vehicle motion

3.20

lateral offset

lateral distance between the longitudinal centerlines of a subject vehicle (SV) and a target vehicle (TV), measured as a percentage of the width of the SV, such that if the centers of the two vehicles are aligned, the value is zero

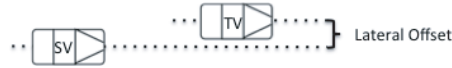

3.21

light vehicle

any single vehicle or combination of vehicles defined as Category 1-1 in the United Nations Economic and Social Council World Forum for Harmonization of Vehicle Regulations (WP.29) TRANS/WP.29/1045

3.22

mitigation braking

MB

FVCMS countermeasure that responds to the detection of a very likely rear-end collision by automatically activating braking to quickly reduce the relative velocity, within the minimum requirements

3.23

minimum countermeasure action point

MCAP

value of PUP, relative to an expected collision, for which initiation of a specific countermeasure shall be required

3.24

minimum FVCMS deceleration

minimum FVCMS deceleration that the system must achieve while mitigation braking (MB) is active, measured on smooth, dry, clean pavement

3.25

minimum velocity

V_{\min}

minimum subject vehicle (SV) speed for which FVCMS must be capable of activating a countermeasure

3.26

override

driver initiated suppression of an MB, SRB, or CW countermeasure

3.27

pre-collision urgency parameter

PUP

real-time parameter that signifies the urgency of a potential future collision

3.28

rear-end collision

forward vehicle collision in which the front of the subject vehicle strikes the rear of the forward vehicle

3.29

relative velocity

$v_r(t)$

difference in longitudinal velocity between the subject vehicle (SV) and the target vehicle (TV), $v_r(t)$, given by the equation with a positive value signifying that the target vehicle is moving faster than the subject vehicle, and therefore the clearance is increasing with time

$$v_r(t) = v_{TV}(t) - v_{SV}(t)$$

3.30

required deceleration

minimum deceleration that, if constant, would enable the subject vehicle to match the velocity of the target vehicle without contacting the target vehicle and thus prevent a collision

3.31

single track vehicle

vehicle that leaves a single ground track as it moves forward

Note 1 to entry: Single track vehicles usually have little to no lateral stability when stationary but develop it when moving forward or controlled.

3.32

speed reduction braking

SRB

FVCMS countermeasure that reduces the subject vehicle speed by activating the brakes allowing the driver time to analyse and respond to a potential collision, which may have the additional effect of drawing driver attention to hazards ahead of the subject vehicle (SV)

3.33

subject vehicle

SV

vehicle equipped with FVCMS as defined herein

3.34

target vehicle

TV

forward vehicle that is within the effective range of the subject vehicle (SV)'s forward ranging sensor

3.35

time gap

value calculated from vehicle speed and clearance by: Time Gap = Clearance / Vehicle Speed

3.36

time to collision

TTC

time that it will take a subject vehicle to collide with the target vehicle assuming the relative velocity remains constant, as given in the following equation:

$$TTC = -\frac{x_c}{v_r}$$

3.37

truck-tractor

heavy single-chassis vehicle providing propulsion, control, and crew (driver) accommodation, with the primary purpose of controlling and transporting one or more separate load-carrying trailers

3.38

unit truck

heavy single-chassis vehicle providing its own propulsion, control, and crew (driver) accommodation, with a significant cargo or other payload section

3.39

warning braking

WB

action in which FVCMS respond to detection of a possible rear-end collision by automatically activating the brake to provide a warning to the driver

4 Symbols (and abbreviated terms)

| | |
|--------------|---|
| a_{TV} | Acceleration of the TV |
| a_{SV} | Acceleration of the SV |
| ABS | Anti-lock Brake System |
| ACC | Adaptive Cruise Control |
| CAP | Countermeasure Action Point |
| CTT | Coefficient for Test Target |
| CW | Collision Warning |
| D_{TV} | Deceleration of target vehicle |
| D_{SV} | Deceleration of subject vehicle |
| d_{max} | Maximum detectable distance |
| d_1 | Minimum detectable distance for a laterally offset vehicle |
| d_2 | Minimum distance with distance measuring |
| d_0 | Minimum detectable distance without distance measuring |
| h | Upper limit of detectable zone, from ground |
| h_1 | Lower limit of detectable zone, from ground |
| ESC | Electronic Stability Control |
| ETTC | Enhanced Time to Collision |
| FV | Forward Vehicle |
| FVCWS | Forward Vehicle Collision Warning Systems |
| FVCMS | Forward Vehicle Collision Mitigation Systems |
| MB | Mitigation Braking |
| $MCAP_{MB}$ | Minimum Countermeasure Action Point for Mitigation Braking |
| $MCAP_{SRB}$ | Minimum Countermeasure Action Point for Speed Reduction Braking |
| $MCAP_{CW}$ | Minimum Countermeasure Action Point for Collision Warning |
| PUP | Pre-collision Urgency Parameter |
| RCS | Radar Cross Section |
| RSC | Roll Stability Control |
| SRB | Speed Reduction Braking |
| SV | Subject Vehicle |
| TTC | Time to Collision |
| TV | Target Vehicle |
| V_{min} | Minimum SV path velocity for FVCMS operation |
| $v_{SV}(t)$ | Subject vehicle path velocity |
| $v_r(t)$ | Relative path velocity between SV and TV |
| $v_{TV}(t)$ | Target vehicle path velocity |
| V_{max} | Maximum SV path velocity for FVCMS operation |
| WB | Warning Braking |
| W_v | Width of subject vehicle |

W_l Width of lane
 $x_c(t)$ Distance between SV and TV

5 Classifications

This Clause provides introductory information that explains the different classifications of FVCMS that are covered by this International Standard. This Clause is not intended to define requirements. All requirements of this International Standard appear in Clauses 6 and 7.

5.1 System classification by curve radius capability

Systems are classified according to curve radius capability as shown in Table 1.

Table 1 — System classifications

| Class | Horizontal curve radius capability |
|-------|---|
| I | curve radius greater than or equal to 500 m |
| II | curve radius greater than or equal to 250 m |
| III | curve radius greater than or equal to 125 m |

Class I systems shall have the capability to detect forward obstacle vehicles in the subject vehicle's trajectory along curves of radii down to 500 meters.

Class II systems shall have the capability to detect forward obstacle vehicles in the subject vehicle's trajectory along curves of radii down to 250 meters.

Class III systems shall have the capability to detect forward obstacle vehicles in the subject vehicle's trajectory along curves of radii down to 125 meters.

5.2 Classification by countermeasure types included

FVCMS may be classified based on the countermeasures that are provided. Classification is based on the minimum countermeasures and on additional countermeasures that may be provided. Each countermeasure has an associated minimum countermeasure action point (MCAP). FVCMS activate a countermeasure when the pre-collision urgency parameter (PUP) is at least equal to the minimum countermeasure action point for that countermeasure.

5.2.1 Collision Warning (CW) countermeasure

Collision Warning is a warning based on some combination of audible, visual and tactile or haptic sensory modes, meeting the requirements of ISO 15623 for the operation range of FVCMS as depicted in Figure 4.

A Collision Warning countermeasure shall occur no later than the initiation of SRB or MB.

5.2.2 Speed Reduction Braking (SRB) countermeasure

Speed reduction braking is an automatic braking function, intended to reduce subject vehicle velocity. SRB affords the driver an improved opportunity to apply manual emergency braking, to make an emergency lane change, or to determine that no hazard is present and to disengage SRB. Any of these actions could prevent MB from activating. To assist the occupants to prepare for this braking event, SRB actuation is preceded by a Collision Warning countermeasure.

SRB will not be initiated if MB is active.

5.2.3 Mitigation Braking (MB) Countermeasure

Mitigation braking is automatic braking applied when a collision appears unavoidable. MB will be initiated if the PUP is at least equal to the threshold value, $MCAP_{MB}$.

The activation of the mitigation braking countermeasure will result in an impact that is less damaging than it would be if the SV and a TV collided without any mitigation. In some scenarios it may also lead to automatically avoiding the collision. The peak acceleration and the jerk are limited by the design and condition of vehicle systems, and by available traction. To assist the occupants to prepare for this braking event, MB actuation will be preceded by a Collision Warning countermeasure, and optionally by the activation of SRB.

5.2.4 Combining countermeasures

The possible configurations for FVCMS are presented in Table 2 below. Each row represents a distinct system Type. Any combinations which are not identified in this Table are not within the scope of this International Standard. For each Type, the row indicates which countermeasures are required. A "1" indicates that the countermeasure is required, and a "0" indicates that the countermeasure shall not be included.

Table 2 — Permissible system configurations

| Type | MB | SRB | CW |
|------|----|-----|----|
| 1 | 0 | 1 | 1 |
| 2 | 1 | 0 | 1 |
| 3 | 1 | 1 | 1 |

6 Requirements

6.1 Minimum enabling capabilities

The definition of FVCMS performance requires that the subject vehicle be equipped with at least one means for accomplishing each of the necessary system functions. All FVCMS shall provide CW in accordance with ISO 15623 for the operation range of FVCMS as depicted in Figure 4.

6.1.1 Light vehicle necessary functions

Light vehicles equipped with FVCMS shall be capable of fulfilling the following functions:

- detect the presence of forward vehicles;
- determine the range and closing velocity between the SV and the detected forward vehicles;
- determine the subject vehicle velocity;
- initiate appropriate FVCMS countermeasures when the lateral offset is less than 20 %, even if part of the TV is occluded from SV sensors;
- provide driver warnings in accordance with the FVCWS requirements;
- activate and modulate the brakes whether or not the driver is already braking;
- control the brake light;

- enhance driver control based on brakes with a yaw stability capability and a capability to manage longitudinal wheel slip, e.g. an ESC or RSC system combined if necessary with an ABS capability;
- generate at least the minimum required FVCMS deceleration during an MB event for Type 2 and 3 systems;
- have the capability to provide the SRB braking profile for Type 1 or Type 3 systems;
- after MB or SRB has been initiated, permit the driver to increase the deceleration to any higher value up to the maximum possible vehicle deceleration.

6.1.2 Heavy vehicle necessary functions

Heavy vehicles equipped with FVCMS shall fulfil the same functions as light vehicles, but with the following added function:

- FVCMS countermeasures shall not lead to jack-knifing (the folding, at the linkage between cab and trailer, of an articulated vehicle until the cab and trailer form a “V” shape).

6.2 Operating model — State Transition Diagram

The FVCMS shall function according to the State Transition Diagram of Figure 2. Specific implementation, beyond what is illustrated below, of the state transitions is left to the manufacturer.

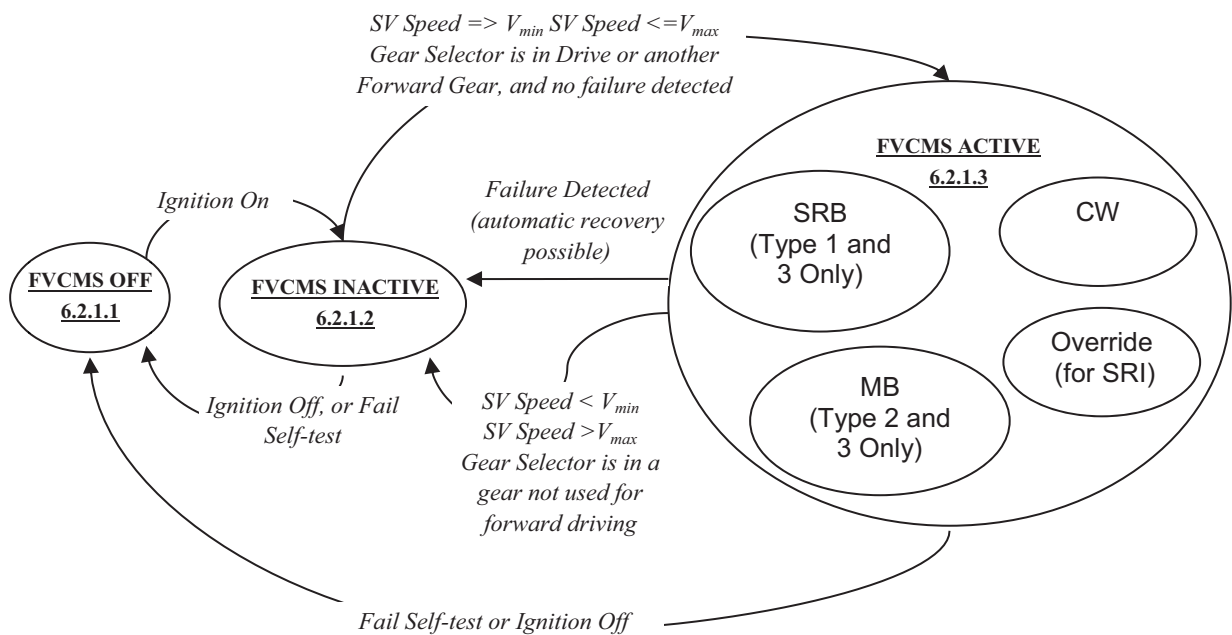

Figure 2 — FVCMS State Transition Diagram

The FVCMS may optionally function according to the State Transition Diagram of Figure 3. Specific implementation, beyond what is illustrated below, of the state transitions is left to the manufacturer.

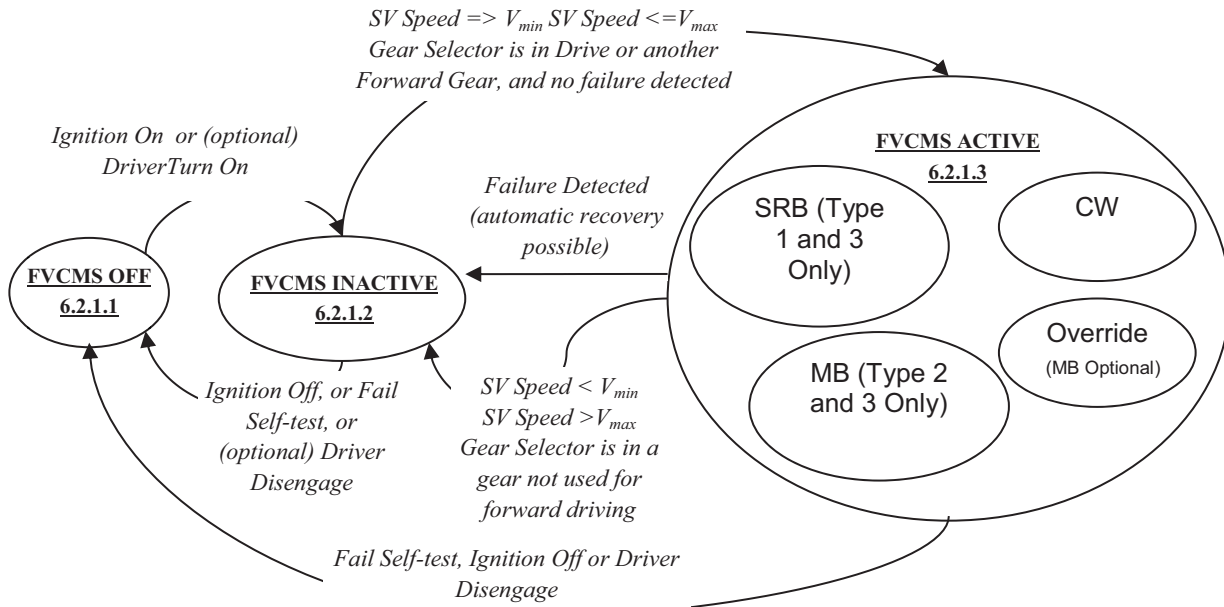

Figure 3 — FVCMS State Transition Diagram including optional features

6.2.1 State functional descriptions

The FVCMS state descriptions address the functional requirements of FVCMS, identifying which functions shall be performed in each state.

6.2.1.1 FVCMS Off

No countermeasures are performed in the FVCMS Off state. Upon turning the ignition to the off position, FVCMS shall transition to the FVCMS Off state. Whenever the self-test function determines that FVCMS are not able to deliver adequate performance, or when the driver manually disengages the FVCMS (optional), it shall transition to the FVCMS Off state. FVCMS may be in the FVCMS Off state when the vehicle is on.

6.2.1.2 FVCMS Inactive

In the FVCMS Inactive state, FVCMS shall monitor vehicle speed and gear status and determine if it is appropriate to activate the system.

FVCMS shall enter the FVCMS Inactive state from the FVCMS Off state if the ignition cycle has been completed and the engine is running. FVCMS shall enter this state from the Active state if the conditions for activating are not met. For example, if the vehicle speed drops below V_{min} , Reverse gear is selected, or Park is selected. Based on the results of a diagnostic self-test, function of all or some of the countermeasures may be restored. If a manufacturer defined failure mode is encountered for which an automatic recovery (optional) is possible, the FVCMS shall transition from FVCMS Active state to FVCMS Inactive state. Once the recovery occurs the system may transition back to FVCMS Active state. Finally, if the driver manually engages FVCMS (optional), then it shall transition from the FVCMS Off state to the FVCMS Inactive state.

6.2.1.3 FVCMS Active

The FVCMS when Active shall monitor for triggering conditions resulting in the selection of appropriate countermeasures, and decide to activate or optionally override countermeasures.

If a system failure occurs or there is an inability to perform a countermeasure, FVCMS shall transfer to the FVCMS Inactive state if automatic recovery from the failure is possible. If the system fails a self-test

(automatic recovery without driver intervention is not possible) FVCMS shall transfer to the FVCMS Off state. Means of notification of these failures to the driver is left up to the manufacturer.

FVCMS shall enter this state if gear select is in Drive or any forward motion selection and the vehicle speed is greater than or equal to V_{\min} and less than V_{\max} .

6.3 Performance requirements

The requirements of this Subclause are applicable to driving conducted on clean, smooth, dry pavement.

6.3.1 Target vehicle types

FVCMS shall provide countermeasure actions when needed based on detected licensable motor vehicles intended for use on public roads, i.e. motorcycles, cars, light trucks, buses, motor coaches, and other heavy vehicles. FVCMS may optionally detect smaller targets, such as pedestrians and human-powered cycles.

6.3.2 Collision types

FVCMS shall function in rear-end collision scenarios with respect to all target vehicles.

6.3.3 Operating speed

The operating speed and relative speed constraints are shown in Figure 4. Regions coloured pink (the shaded zone above the diagonal line) represent conditional operation conditions; regions coloured green (the shaded zones below the diagonal line) are May-operate cases; and regions coloured grey are must-operate conditions. The upper limits on maximum speed for operation, both for the subject vehicle and the target vehicle, are left to the manufacturer.

6.3.3.1 Subject vehicle

FVCMS shall initiate countermeasures (as defined in 6.3.6.4.1 for MB and 6.3.6.5.1 for SRB) if conditions are met and if the subject vehicle speed is between V_{\min} and V_{\max} .

6.3.3.1.1 Minimum subject vehicle speed (V_{\min})

All FVCMS shall have V_{\min} of 8,4 m/s (30 km/h) or less.

FVCMS shall enter the Inactive state if the subject vehicle speed drops below V_{\min} and mitigation braking is not in process. The value of V_{\min} shall be declared in the owner's manual.

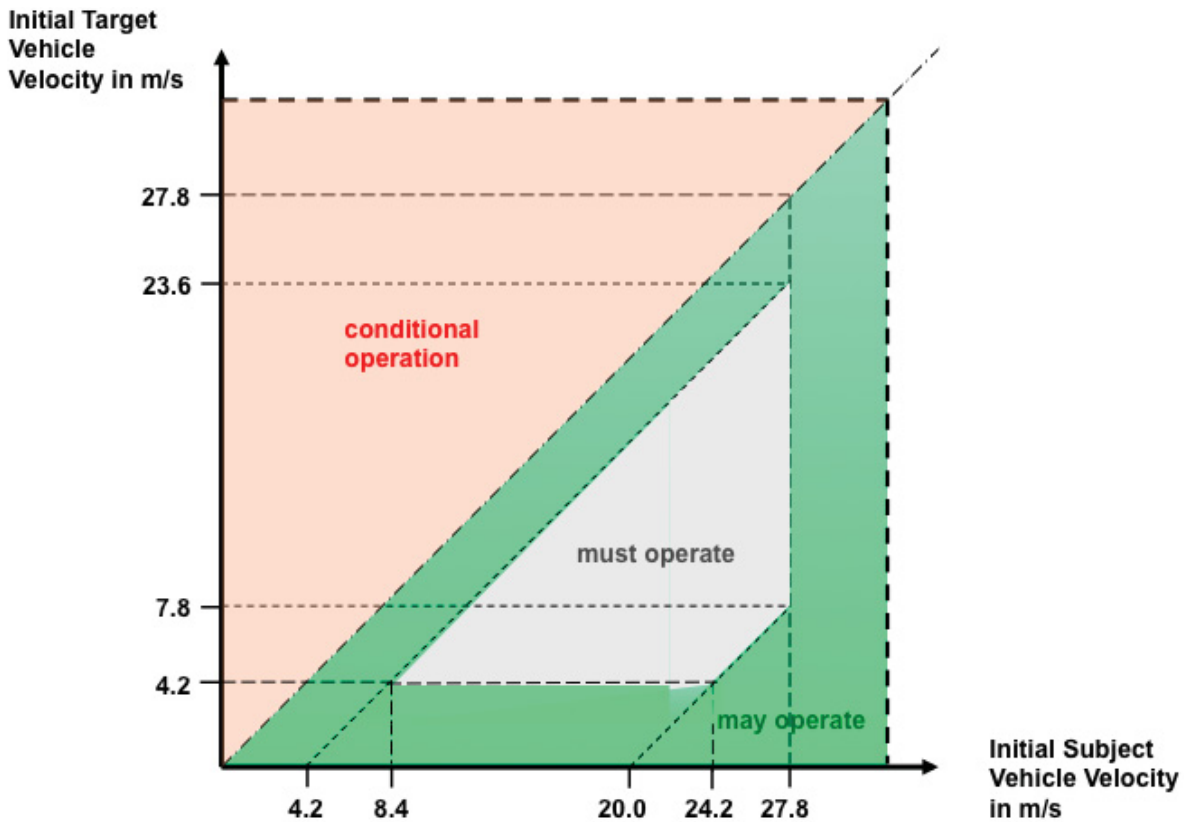

Figure 4 — Operation range of FVCMS

6.3.3.1.2 Maximum subject vehicle speed (V_{max})

All FVCMS shall have V_{max} of 27,8 m/s (100 km/h) or greater or the maximum vehicle speed in case it is below 27,8 m/s.

The value of V_{max} shall be declared in the owner's manual if it is less than the speed capability of the car.

6.3.3.2 Target vehicle

6.3.3.2.1 Minimum target vehicle speed

The minimum target vehicle speed shall not be greater than 4,2 m/s for any subject vehicle speed.

The minimum target vehicle speed for initial FVCMS detection shall be determined by the SV manufacturer.

FVCMS shall function for any target vehicle speed within the detection range constraints of 6.3.4 and remain functional while the target vehicle reduces its speed to 0 m/s.

FVCMS shall also meet the relative velocity requirements of 6.3.3.3.

6.3.3.2.2 Maximum target vehicle speed

FVCMS shall function for target vehicles moving at any speed up to V_{max} less the minimum relative velocity (as defined in 6.3.3.3) consistent with the operation range of FVCMS depicted in Figure 4.

6.3.3.2.3 Maximum lateral offset (lateral discrimination)

FVCMS shall function when the lateral offset is 20 % or lower in either direction. FVCMS may function for lateral offsets greater than 20 % at the discretion of the manufacturer.

6.3.3.2.4 Maximum lateral speed

When there is a lateral offset, FVCMS shall function for relative vehicle lateral speeds of less than 0,2 m/s. FVCMS may function for relative vehicle lateral speeds greater than 0,2 m/s at the discretion of the manufacturer.

6.3.3.3 Relative velocity

FVCMS shall function for any relative velocity condition when the SV is closing in on the TV and the relative velocity $v_r(t)$ is between $-4,2$ m/s (-15 km/h) and -20 m/s (-72 km/h). Manufacturers may extend the operating zone beyond these limits at their discretion.

If the required deceleration exceeds the minimum required deceleration for MB due to a deceleration of a target vehicle, then the subject vehicle is permitted to apply SRB or MB in the conditional operation zone of Figure 4. If the ETTC is less than 4 s, then the system is permitted to apply SRB in the conditional operation zone.

6.3.4 Target vehicle detection area

FVCMS shall monitor the area ahead of the SV whenever it is in the Active state. Sensor type(s) and mounting location(s) are left up to the manufacturer. The width of the detection range for horizontal curve radius shall be extended in relation to the curve's radius as per ISO 15623.

6.3.4.1 Minimum detection area

The minimum detection area shall be as defined in Figure 5, and Tables 3 and 4.

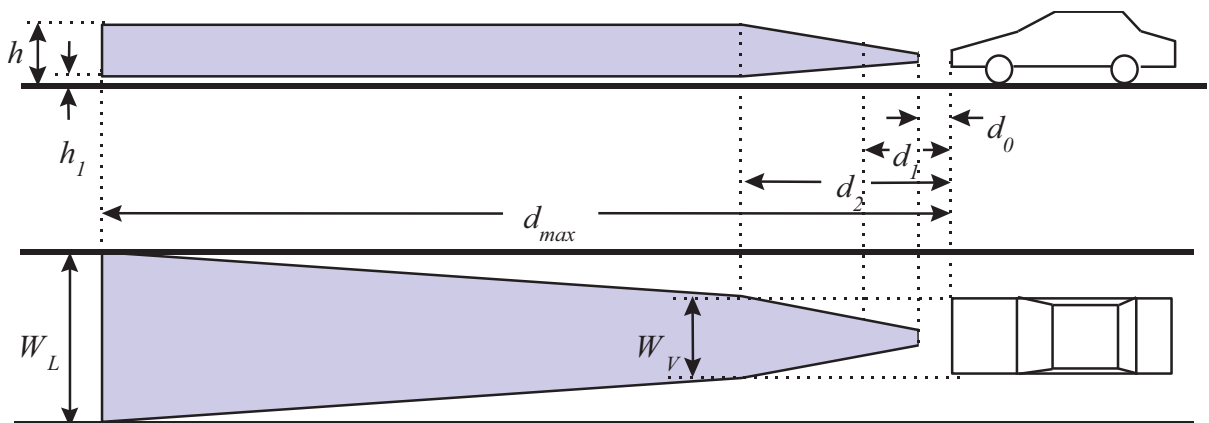

Figure 5 — Minimum detection area

6.3.4.2 Detection range

Table 3 — Detection range

| Distance | Formula or value | Meaning |
|-----------|--|--|
| d_{max} | <i>shall be the distance at which $PUP = MCAP_{CW}$</i> | The maximum detectable distance. |
| d_2 | Shall be less than or equal to 10 m for Class I May be less than or equal to 7,5 m for Class II May be less than or equal to 5 m for Class III | The minimum detection distance for a forward vehicle with a lateral offset of less than 20 %. Class as defined in ISO 15623. |
| d_1 | <i>Shall at least be the distance at which $PUP \geq MCAP_{MB}$</i> | The system minimum distance with distance measuring capability. |
| d_0 | Shall be less than or equal to 2 m | The minimum distance at which target vehicle presence can be determined without distance measuring capability. |

where $MCAP_{CW}$ and $MCAP_{MB}$ are design parameters for actual systems.

The values of these parameters are determined by the vehicle manufacturer.

6.3.4.3 Detection width and detection height

Table 4 — Detection width and detection height requirements

| Distance | Minimum detection width | Minimum detection height |
|-----------|--------------------------------------|---|
| d_{max} | W_L (lane width) meters | h_1 (lower detection height from ground) = 0,2 m and h (upper detection height from ground) = 1,1 m |
| d_2 | W_V (subject vehicle width) meters | h_1 (lower detection height from ground) = 0,2 m and h (upper detection height from ground) = 1,1 m |
| d_1 | not specified | not specified |
| d_0 | not specified | not specified |

6.3.5 Target discrimination

6.3.5.1 Longitudinal discrimination

If two or more forward vehicles are detected, FVCMS shall base countermeasure actions on the one with the value of PUP indicating the greatest probability of collision.

6.3.5.2 Lateral discrimination

If one forward vehicle is in the subject vehicle path and a forward adjacent vehicle is present, the system shall base warnings and mitigation braking on the vehicle in the subject vehicle path.

6.3.5.3 Overhead discrimination

The FVCMS shall not initiate MB, SRB, or CW countermeasures based on the detection of overhead targets at a height greater than 4,5 m above the roadway.

6.3.6 Countermeasure requirements

6.3.6.1 Provision of MB or SRB

All FVCMS shall provide MB or SRB.

6.3.6.2 Provision of CW

All FVCMS shall provide CW.

6.3.6.3 Brake light control

If FVCMS applies automatic service braking, the brake lights shall be illuminated. The brake lights shall be illuminated within 350 ms after FVCMS initiates the automatic service brake. To prevent irritating brake light flickering, the brake light may remain on for a reasonable time after the FVCMS initiated braking has ended.

6.3.6.4 Mitigation braking requirements

The following requirements represent minimum functionality as defined for FVCMS operation. Manufacturers may exceed this minimum functionality at their discretion.

6.3.6.4.1 Initiation of mitigation braking

6.3.6.4.1.1 Light vehicles

MB shall not be initiated for TTC or ETTC above 3,0 s to achieve the deceleration requirement of 6.3.6.4.2.

6.3.6.4.1.2 Heavy vehicles

MB shall not be initiated for TTC or ETTC above 4,0 s to achieve the deceleration requirement of 6.3.6.4.2.

6.3.6.4.2 Minimum deceleration in mitigation braking

6.3.6.4.2.1 Light vehicles

FVCMS shall generate a deceleration at least $5,0 \text{ m/s}^2$ (0,51 g) for a duration chosen to achieve a speed reduction of at least 2,0 m/s. FVCMS with both MB and SRB combined (Type 3) shall generate a minimum speed reduction of at least 4,0 m/s. This requirement does not constrain the time when mitigation braking is activated.

6.3.6.4.2.2 Heavy vehicles

FVCMS shall generate a deceleration at least $3,3 \text{ m/s}^2$ (0,34 g) for a duration chosen to achieve a speed reduction of at least 1,0 m/s. This requirement does not constrain the time when mitigation braking is activated.

6.3.6.4.3 Driver-commanded enhancement of mitigation braking

FVCMS shall allow a driver-initiated increase in braking force unless the SV is already braking at its maximum capability.

6.3.6.4.4 Termination of mitigation braking

FVCMS may deactivate mitigation braking if the PUP becomes less than MCAP_{mb} . If such deactivation is implemented, and the PUP changes quickly in response to SV and TV relative position or path velocity changes, the manufacturer may prevent chattering, e.g. by introducing hysteresis into the deactivation control.

6.3.6.4.5 Driver initiated override of mitigation braking

FVCMS may optionally permit the driver to override mitigation braking by driver actions in a manner to be defined by the manufacturer. After MB has been activated and the driver has overridden it, MB may again activate after driver override has ended.

6.3.6.4.6 Braking with reduced traction

Mitigation braking shall not lead to locked wheels for periods longer than anti-lock or stability control devices (ABS/RSC) would allow.

6.3.6.5 Speed reduction braking

The following requirements represent minimum functionality as defined for FVCMS operation. Manufacturers may exceed this minimum functionality at their discretion.

6.3.6.5.1 Initiation of SRB

SRB shall not be initiated for TTC or ETTC above 4,0 s. The activation point shall be decided by the manufacturer.

6.3.6.5.2 Maximum deceleration in SRB

The average deceleration generated by SRB when active shall not exceed the line $d_{SV} = 5,33 \text{ m/s}^2 - 0,067/\text{s} \cdot v_{SV}$ (averaged over the first time period T_{1_SRB} sec) for any SV speed between 5,0 m/s and 20 m/s; where d_{SV} is the deceleration of the SV, and v_{SV} is the speed of the SV, and $d_{SV} = -a_{SV}$.

The average deceleration generated by SRB shall not exceed, in the first time period T_{1_SRB} of the SRB, $4,0 \text{ m/s}^2$ (averaged over the first time period T_{1_SRB} sec) for $v_{SV} > 20 \text{ m/s}$ or 5 m/s^2 for $v_{SV} < 5 \text{ m/s}$ (as depicted in Figure 6).

After a time period of at least T_{1_SRB} , the maximum allowed deceleration of the SRB may be continuously increased up to 6 m/s^2 (averaged over 1 sec). For Type 3 and 1: $T_{1_SRB} > = 0,5 \text{ sec}$.

The average jerk achieved during SRB, while increasing the maximum deceleration, shall not exceed $6,0 \text{ m/s}^3$ (averaged over 0,5 s).

Refer to Figure 6 Maximum SRB Deceleration for an illustration of this requirement. Refer to Figure 7 for an illustration of the continuous deceleration increase.

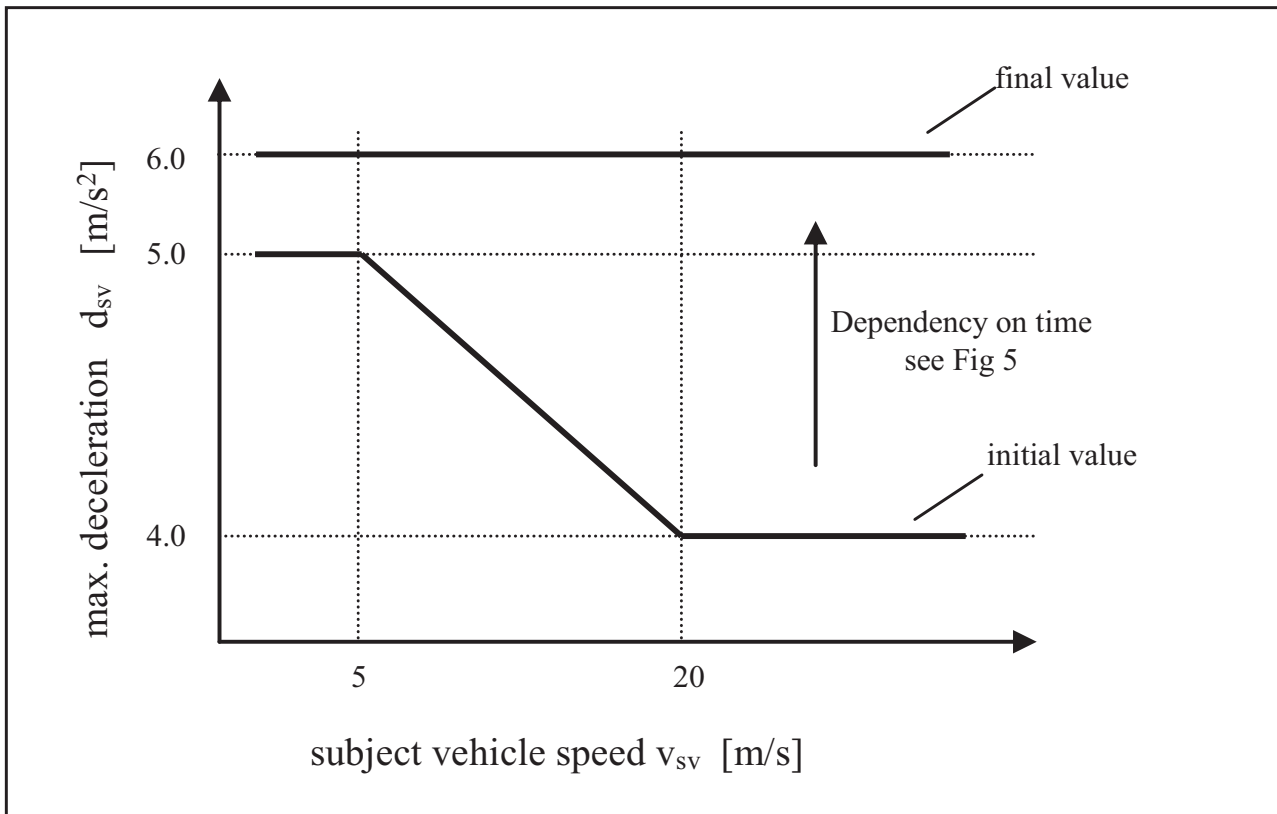

Figure 6 — Maximum SRB deceleration, showing continuous transition in deceleration requirement

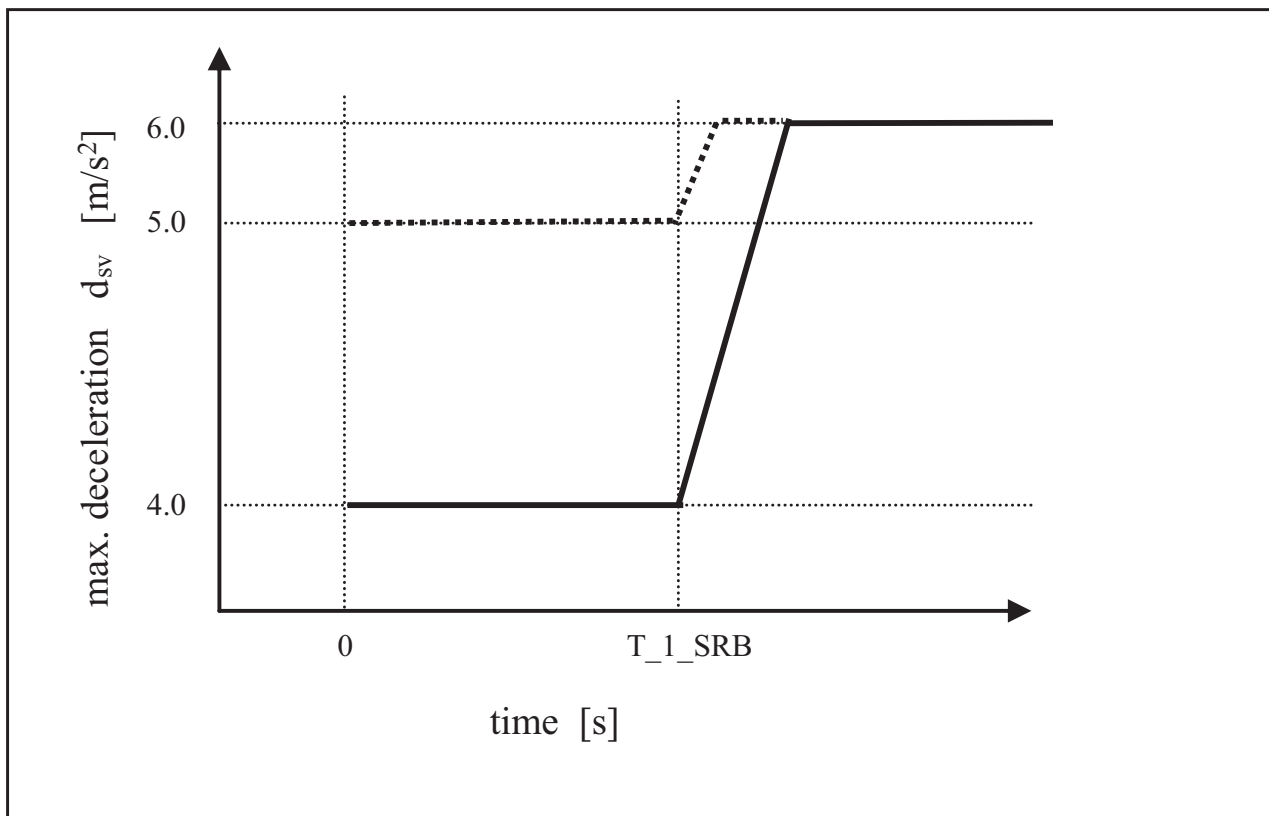

Figure 7 — Time-based deceleration change in SRB

6.3.6.5.3 Minimum effectiveness of SRB

SRB-only (Type 1) systems shall at minimum reduce speed to the same degree as the minimum requirement for the MB function.

6.3.6.5.4 SRB with reduced traction

SRB shall not lead to locked wheels for periods longer than anti-lock or stability control devices (ABS/RSC) would allow.

6.3.6.5.5 Driver initiated override of speed reduction braking

FVCMS shall permit the driver to override speed reduction braking by driver actions in a manner to be defined by the manufacturer.

6.3.6.6 Collision warning

The Collision Warnings shall consist of a countermeasure based on some combination of audible, visual and tactile or haptic sensory modes, consistent with ISO 15623.

6.3.7 Driver controls and human interface

6.3.7.1 Light vehicles

6.3.7.1.1 System limitation information

The driver shall at least be informed of FVCMS operating limitations by means of the owner's manual or equivalent alternative.

6.3.7.1.2 Driver disengagement of FVCMS

The driver may be provided with a means to disengage FVCMS.

For systems that have a means to manually transition from FVCMS Active state and/or FVCMS Inactive state to FVCMS Off state, the driver should be able to easily determine the system state.

6.3.7.1.3 FVCMS fault indication

The driver shall be provided with an indication of system failure.

6.3.7.2 Heavy vehicles

6.3.7.2.1 Target vehicle detection information

If not otherwise provided, the FVCMS may indicate to the driver when a target vehicle has been detected. This added early driver information may help to avoid the long braking delay and stopping distance experienced by drivers of heavy vehicles.

6.3.7.2.2 FVCMS limitation information

The driver shall at least be informed of FVCMS operating limitations by means of the owner's manual.

6.3.7.2.3 Driver disengagement of FVCMS

The driver may be provided with a means to disengage FVCMS.

For systems that have a means to manually transition from FVCMS Active state and/or FVCMS Inactive state to FVCMS Off state, the driver should be able to easily determine the system state.

6.3.7.2.4 System fault indication

The driver shall be provided with an indication of system failure.

7 Validation methods

7.1 Test target specification

7.1.1 Detectability specifications

7.1.1.1 Optical radar (i.e. lidar or ladar)

7.1.1.1.1 Vehicle target

The test target is defined as possessing the physical size, shape, and surface profile of a representative passenger vehicle and with a CTT (Coefficient for Test Target) which represents the reflectivity of a passenger vehicle.

7.1.1.1.2 Motorcycle target

The test target is defined as possessing the physical size, shape, and surface profile of a representative motorcycle and with a CTT (Coefficient for Test Target) which represents the reflectivity of motorcycles.

7.1.1.1.3 Overhead target

The test target is defined as possessing the physical size, shape, and surface profile of a representative motorway structure that typically extends over a roadway and with a CTT (Coefficient for Test Target) which represents the reflectivity of a motorway structure.

7.1.1.2 Radio wave radar

7.1.1.2.1 Vehicle target

The test target is defined as possessing the physical size, shape, and surface profile of a representative passenger vehicle and with an RCS (Radar Cross Section) which represents the reflectivity of a passenger vehicle.

7.1.1.2.2 Motorcycle target

The test target is defined as possessing the physical size, shape, and surface profile of a representative motorcycle and with an RCS that is representative of motorcycles.

7.1.1.2.3 Overhead target

The test target is defined as possessing the physical size, shape, and surface profile of a representative motorway structure that typically extends over a roadway and with an RCS which represents the reflectivity of a motorway structure.

7.1.1.3 Passive optical sensor

7.1.1.3.1 Vehicle target

The test target is defined as possessing the physical size, shape, and surface profile of a representative passenger vehicle.

7.1.1.3.2 Motorcycle target

The test target is defined as possessing the physical size, shape, and surface profile of a representative motorcycle with a rider.

7.1.1.3.3 Overhead target

The test target is defined as possessing the physical size, shape, and surface profile of a representative motorway structure that typically extends over a roadway.

7.1.2 Test target physical constraints

7.1.2.1 Optical radar (i.e. lidar or ladar)

The CTT only describes the quality of a reflector (damping). The smallest acceptable test target is a corner reflector with the required CTT. It is permissible to use a test object with a larger surface of reflection, if it meets the same CTT requirement.

7.1.2.2 Radio wave radar

Test target geometry is discussed in Annex D of ISO 15623.

7.1.2.3 Passive optical sensor

Test targets should provide a surface profile representative of a motorcycle with rider and a passenger vehicle. The test target should limit deformation of the surface if an inflatable target is utilized. Reflectivity should be consistent with production vehicles.

7.2 Environmental conditions

The following subclauses describe environmental conditions that shall exist when the functionality according to the standard is tested. These environmental conditions are not meant to be exhaustive or restrictive in assessing system performance. This does not preclude manufacturers from testing during additional conditions.

7.2.1 Driving surface

Test location shall be on a flat, dry asphalt or concrete surface. The friction between the subject vehicle's tires and the driving surface at the time of the tests shall be high enough to support the maximum braking action permitted to the system under test.

7.2.2 Lighting conditions

There are no restrictions on lighting conditions for the test. Testing may occur during daylight conditions.

7.2.3 Ambient air temperature

Temperature range shall be -20°C to 40°C . Testing may occur outside this temperature range at the discretion of the manufacturer.

7.2.4 Horizontal visibility

Horizontal visibility shall be greater than 1 km.

7.3 Test method for detection zone

The most realistic test for detection area is a dynamic test, however, a static test is available as an option also. The test shall be done as follows. The system shall detect a test target positioned at an arbitrary distance between d_0 and d_1 as shown in Figure 8.

The system shall detect a test target positioned at an arbitrary distance between d_1 and d_2 as shown in Figure 8. The system shall detect test targets positioned in turn at both distance d_2 and d_{max} as shown in Figure 8.

If detection cannot be validated without special measurement equipment, such as when a sensor and ECU are tightly integrated, the manufacturer may conduct this test using special measurement equipment and provide test results for inspection. Additionally, as this test allows for a dynamic test, it may be conducted simultaneously with another test in Clause 7 such that the intent of this test method is fulfilled in the execution of another test. For example, a test vehicle meeting the previously defined test target specifications maybe used as a test target. Successful initiation of a Collision Warning at the various distances defined in this test may be considered successful detection.

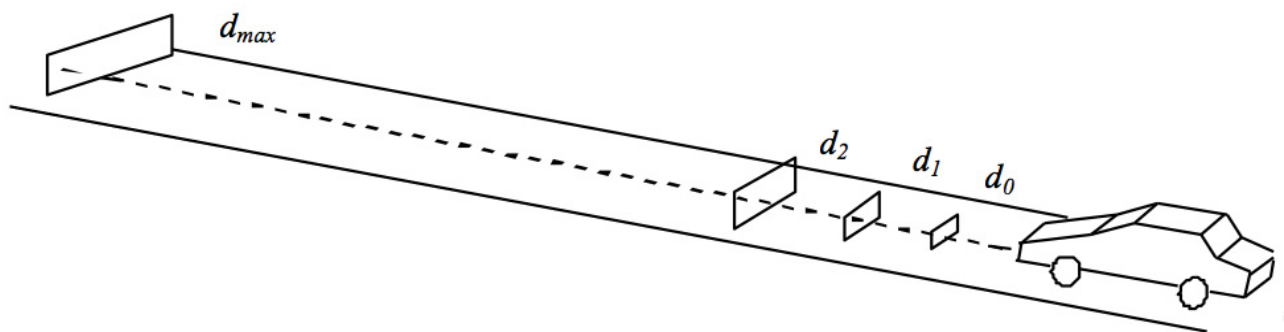

Figure 8 — Detection range

7.4 Test method for functional ability

The test may use standard reflectors in place of target vehicles. The functional ability test consists of one test scenario with 20 ± 2 m/s test speed for the subject vehicle and 8 ± 1 m/s test speed for the target vehicle such that they have nominal relative velocity of -12 m/s. The subject vehicle approaches the target vehicle from far behind. The test is fulfilled when the system produces a Collision Warning and has reached the required speed reduction (and the required deceleration for Type 2 and 3, which meets 6.3.6.4.2 Minimum Deceleration in Mitigation Braking) before a collision happens.

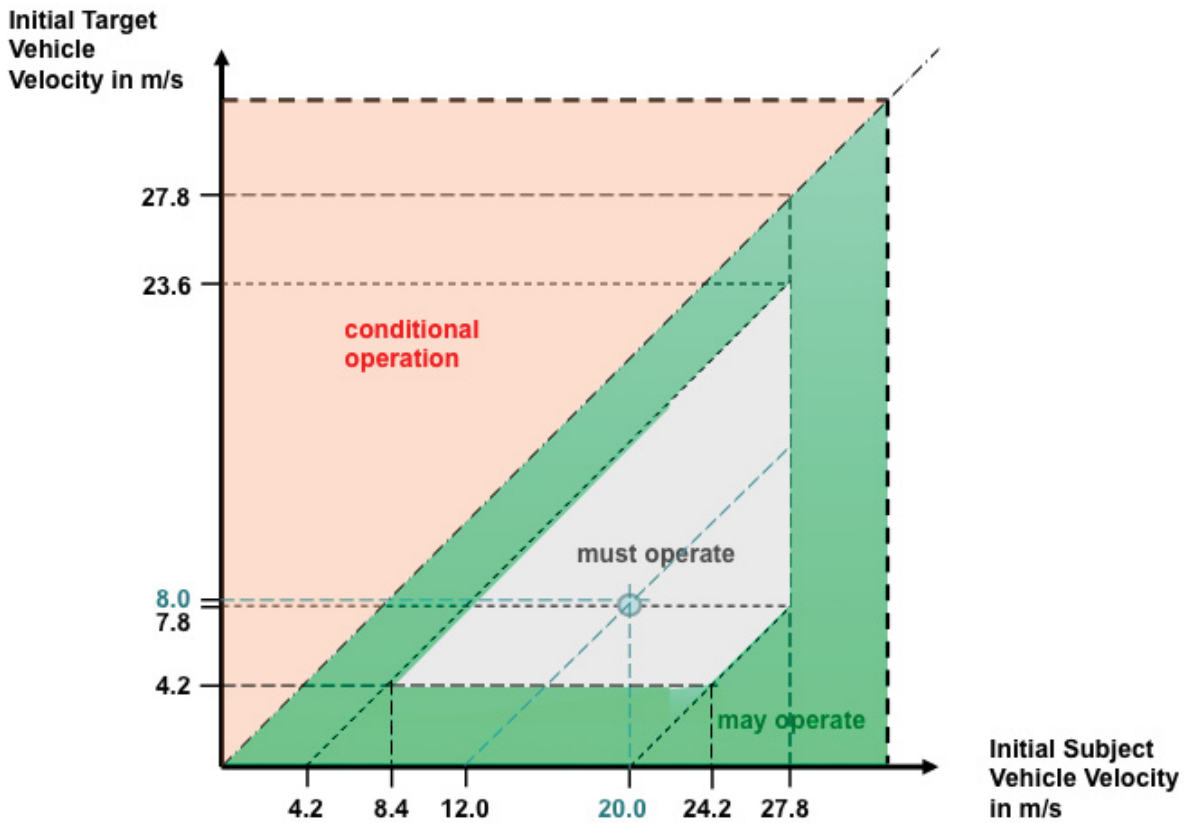

Figure 9 — Functional ability test subject and target vehicle speeds

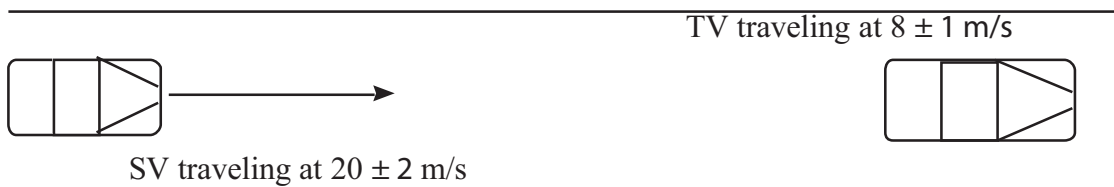

Figure 10 — Test configuration for functional ability

7.5 Test method for target discrimination ability

These tests shall be done with vehicles in motion. The operation sequence for each test in this subclause is finished when the SV produces a Collision Warning. Tests should also show the ability to avoid nuisance warnings. If no warning is produced, the test is complete when the required manoeuvres are complete. At the discretion of the manufacturer, these tests may be extended to assess SRB or MB functionality of the system. Each of these tests can be performed at the SV and TV velocities stated in the functional ability test.

7.5.1 Longitudinal discrimination test

Two target vehicles in the detection area both drive at a speed of 20 m/s. The subject vehicle follows the two target vehicles at a speed of 20 m/s. The time gap between the two target vehicles shall be $0,6 \text{ s} \pm 0,1 \text{ s}$ and the two target vehicles are positioned along a line in such a way that the near target vehicle does not mask the far target vehicle. The time gap between the subject vehicle and the near target vehicle may be over 1,5 s. The subject vehicle approaches the target vehicles until the system produces a Collision Warning. After that, the subject vehicle decelerates until the same time gap (e.g. $\geq 1,5 \text{ sec}$) is reached, and then follows the target

vehicles with the same speed again. Next, after a few seconds only the near target vehicle decelerates to a speed that is low enough to have the subject vehicle produce the Collision Warning. The test is finished when the subject vehicle has produced the Collision Warning.

The test is passed if the triggering points of the warnings are in accordance with the functional triggering thresholds for the near target vehicle considered alone.

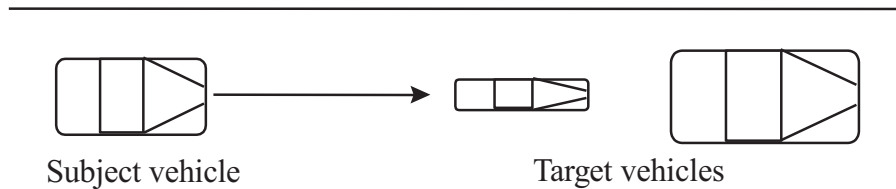

Figure 11 — Longitudinal target discrimination ability test

7.5.2 Straight road lateral discrimination test

The test shall be performed dynamically. Subject vehicle and target vehicle are driving with the same speed, which is 20 m/s, and at a time gap that does not cause a warning. The time gap between the subject vehicle and the target vehicle may be over 1,5 s. The forward vehicle drives beside the target vehicle at the same speed as the target vehicle. The spacing between the longitudinal centrelines of the preceding vehicles is $3,5 \text{ m} \pm 0,25 \text{ m}$. The width of the preceding vehicles shall be between 1,4 m and 2,0 m. The lateral offset of the subject vehicle and target vehicle shall be less than 20 %. After a few seconds the forward vehicle decelerates to a speed that is significantly lower than the speed of the subject and target vehicle. During passing of the forward vehicle, the subject vehicle shall neither produce a warning nor mitigation braking. Next, after a few seconds the target vehicle decelerates to a speed that is low enough to have the subject vehicle produce the Collision Warning. The test is finished, when the subject vehicle has produced the Collision Warning.

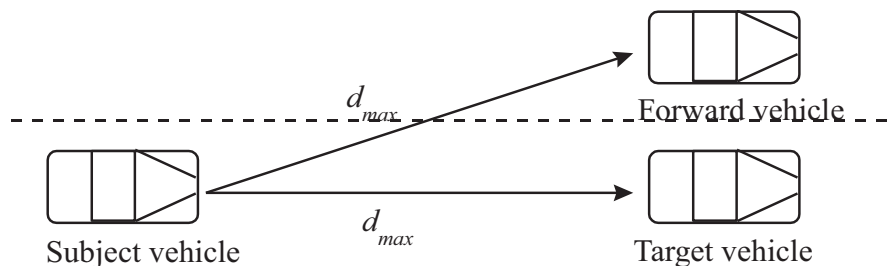

Figure 12 — Straight road lateral target discrimination ability test

7.5.3 Straight road lateral offset discrimination test

The test shall be performed dynamically. Subject vehicle and forward vehicle are driving with the same speed, which is 20 m/s, and a time gap that does not cause a warning. The time gap between the subject vehicle and the target vehicle may be over 1,5 s. The target vehicle drives behind the forward vehicle at a distance greater than d_2 from the subject vehicle at the same speed as the subject and forward vehicles. The width of the target vehicle and forward vehicle shall be between 1,4 m and 2,0 m. The lateral offset of the subject vehicle and forward vehicle shall be less than 20 %. The lateral offset of the SV and target vehicle shall be between 15 % and 20 %. After a few seconds the target vehicle decelerates to a speed that is low enough to have the subject vehicle produce the Collision Warning. The test is finished when the subject vehicle has produced the Collision Warning.

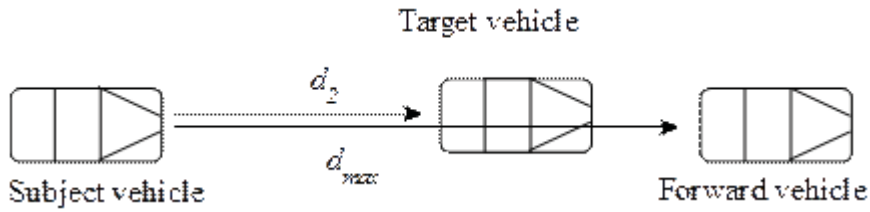

Figure 13 — Straight road lateral offset discrimination ability test

7.5.4 Curved road lateral target discrimination test

In addition to the straight road test, the following test shall be done on a circle or a sufficient part of a circle with a maximum radius of 500 m for a Class I system, with a maximum radius of 250 m for a Class II system, and with a maximum radius of 125 m for a Class III system. The test shall be performed dynamically. Subject vehicle and target vehicle drive in the same lane with the same speed and with a headway that does not cause a warning. The speed of the test vehicles at the start of the test is as follows.

$$V_{circle_start} = \min((a_{lateral_max} \times R)1/2, 20 \text{ m/s}) \pm 1 \text{ m/s}$$

where

- $a_{lateral_max}$ is 2.0 m/s² for Class I;
- $a_{lateral_max}$ is 2.3 m/s² for Class II and III.

The forward vehicle drives beside the target vehicle in the outer lane. After a few seconds the forward vehicle decelerates to a speed that is significantly lower than the speed of the subject and target vehicle. During passing of the forward vehicle, the subject vehicle shall neither produce a warning nor initiate mitigation braking. The TV continues to decelerate so that after several seconds its speed is low enough to have the subject vehicle produce the Collision Warning. The test is finished when the subject vehicle has produced the Collision Warning.

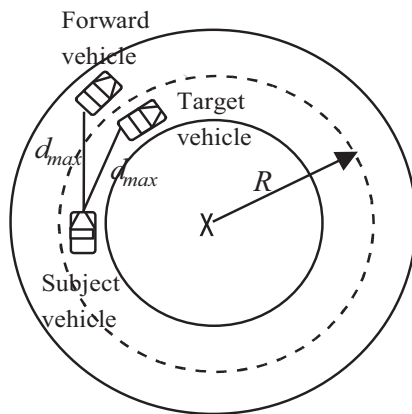

Figure 14 — Curved test track and target discrimination ability test

7.5.5 Overhead discrimination test

The test shall be performed dynamically. As shown in Figure 13, the overhead target that may cause false operation is installed at 4,5 m above the roadway at a distance greater than d_{max} . The subject vehicle approaches the overhead target. The test is finished when the subject vehicle has passed under the overhead target without producing any warning or braking.



Figure 15 — Overhead target discrimination ability test

Annex A (informative)

A.1 Mitigation effectiveness and the potential for collision avoidance

Some simple kinematic calculations indicate that collision mitigation systems can reduce the kinetic energy at impact by a considerable amount. Assume the subject vehicle weight is 1 400 kg, and that the average deceleration due to automatic (not driver-driven) countermeasure braking is 0,5 g. Essentially ideal conditions are assumed for braking surface and traction. The potential reduction in impact kinetic energy is shown in the following graph.

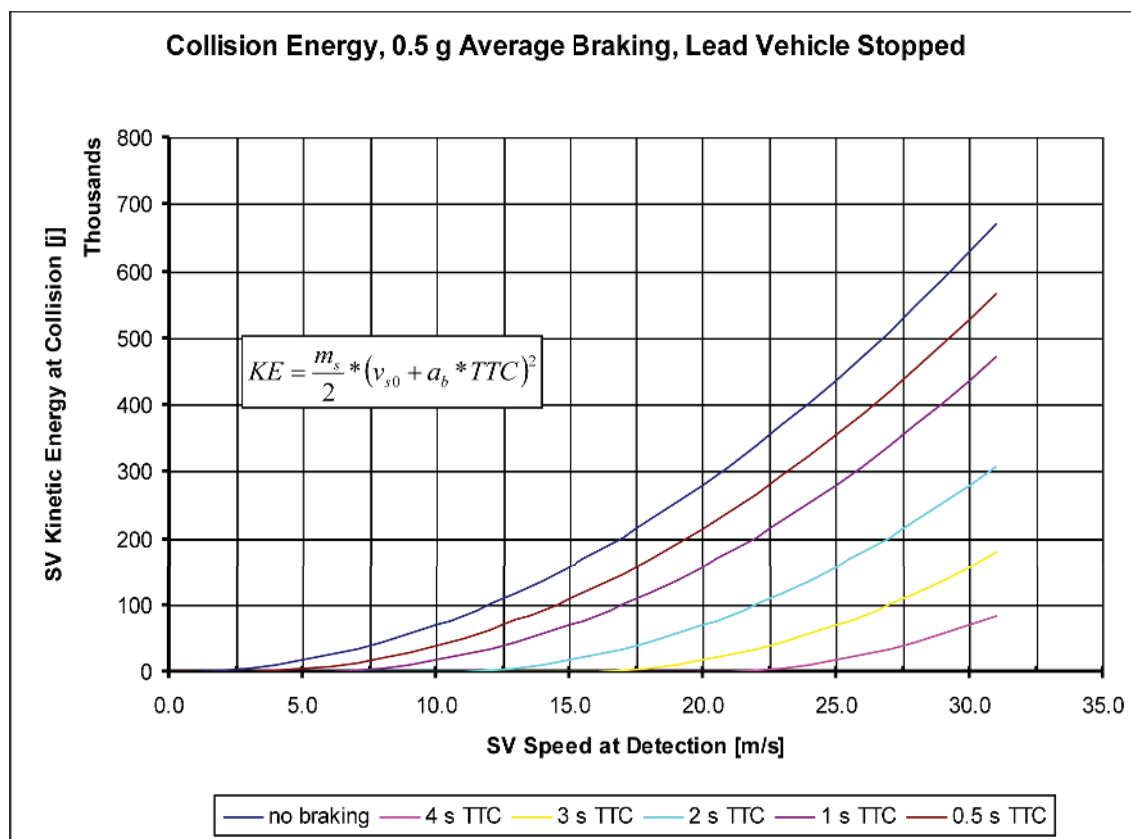

Figure A.1 — Collision energy, 0,5 g average braking, lead vehicle stopped

A.2 Minimum relative speed capability and assumed sensor capability

Table A.1 explores the scenario in which the SV approaches a forward vehicle with a relative speed ranging up to 30 m/s, detects and analyses the forward vehicle for up to 2 s, and brakes at 0,5 g. It computes the distance at which detection must begin (i.e. the effective required sensor range). Sensors with a longer effective range can support stopping the SV from higher speeds. The forward vehicle is not specified as moving or stationary.

By assuming an effective minimum sensor range of 60 m, it can be seen that braking can be initiated for relative speed up to 16,5 m/s (59 km/h, 37 mi/h).

If the free-running time is reduced to 1 s, the maximum speed for a 60 m sensor increases to 20 m/s (72 km/h, 45 mi/h). For zero free-running time, the maximum speed rises only to about 24,5 m/s (88 km/h, 55 mi/h).

To formulate the requirement for minimum relative speed capability, assume T_{free} is 1 sec. Then the requirement is 20 m/s (72 km/h).

Table A.1 — Minimum relative speed capability and assumed sensor capability

| Assumptions | | | | | |
|------------------------------------|------------------------------------|--|--|-------|----------------|
| Automatic breaking deceleration | | | A | 5 | m/s^2 |
| Free-running time | | | T_{free} | 1 | s |
| Speed step increment | | | increment | 1 | m/s |
| (m/s) | (s) | (m) | (m) | (m) | |
| Relative Speed V_{REL} | Braking Time T_{BRAKE} | Braking Distance X_{BRAKE} | Free-running Distance X_{FREE} | Range | |
| 0 | 0,0 | 0,0 | 0,0 | 0,0 | |
| 1 | 0,2 | 0,1 | 1,0 | 1,1 | |
| 2 | 0,4 | 0,4 | 2,0 | 2,4 | |
| 3 | 0,6 | 0,9 | 3,0 | 3,9 | |
| 4 | 0,8 | 1,6 | 4,0 | 5,6 | |
| 5 | 1,0 | 2,5 | 5,0 | 7,5 | |
| 6 | 1,2 | 3,6 | 6,0 | 9,6 | |
| 7 | 1,4 | 4,9 | 7,0 | 11,9 | |
| 8 | 1,6 | 6,4 | 8,0 | 14,4 | |
| 9 | 1,8 | 8,1 | 9,0 | 17,1 | |
| 10 | 2,0 | 10,0 | 10,0 | 20,0 | |
| 11 | 2,2 | 12,1 | 11,0 | 23,1 | |
| 12 | 2,4 | 14,4 | 12,0 | 26,4 | |
| 13 | 2,6 | 16,9 | 13,0 | 29,9 | |
| 14 | 2,8 | 19,6 | 14,0 | 33,6 | |
| 15 | 3,0 | 22,5 | 15,0 | 37,5 | |
| 16 | 3,2 | 25,6 | 16,0 | 41,6 | |
| 17 | 3,4 | 28,9 | 17,0 | 45,9 | |
| 18 | 3,6 | 32,4 | 18,0 | 50,4 | |
| 19 | 3,8 | 36,1 | 19,0 | 55,1 | |
| 20 | 4,0 | 40,0 | 20,0 | 60,0 | |
| 21 | 4,2 | 44,1 | 21,0 | 65,1 | |
| 22 | 4,4 | 48,4 | 22,0 | 70,4 | |
| 23 | 4,6 | 52,9 | 23,0 | 75,9 | |
| 24 | 4,8 | 57,6 | 24,0 | 81,6 | |
| 25 | 5,0 | 62,5 | 25,0 | 87,5 | |
| 26 | 5,2 | 67,6 | 26,0 | 93,6 | |

Table A.1 — (continued)

| Assumptions | | | | | |
|------------------------------------|------------------------------------|--|--|------------------|--|
| Automatic breaking deceleration | | A | 5 | m/s ² | |
| Free-running time | | T _{free} | 1 | s | |
| Speed step increment | | increment | 1 | m/s | |
| (m/s) | (s) | (m) | (m) | (m) | |
| Relative Speed V _{REL} | Braking Time T _{BRAKE} | Braking Distance X _{BRAKE} | Free-running Distance X _{FREE} | Range | |
| 27 | 5,4 | 72,9 | 27,0 | 99,9 | |
| 28 | 5,6 | 78,4 | 28,0 | 106,4 | |
| 29 | 5,8 | 84,1 | 29,0 | 113,1 | |
| 30 | 6,0 | 90,0 | 30,0 | 120,0 | |

where

$$T_{BRAKE} = \frac{V_{REL}}{A}$$

$$x_{BRAKE} = \frac{V_{REL}^2}{2 * A}$$

$$x_{FREE} = V_{REL} * T_{FREE}$$

$$Range = x_{FREE} + x_{BRAKE}$$

A.3 Operating velocity range minimum upper bound

It is proposed that all FVCMS systems shall operate over a subject vehicle velocity range from V_{min} to V_{max}, and that the minimum value of V_{max} shall be 27,8 m/s or 100 km/h. The value of V_{max} is intended to establish a minimum operating speed range that all FVCMS systems must provide to drivers. This operating interval must represent a significant proportion of driving speeds, so the upper limit should be determined based on collected driving speed data.

Data on driving speed was collected as a by-product of the Road Departure Collision Warning Field Operational Test Project. Information about this FOT is available on the US NHTSA websites. The road testing is complete and data analysis is progressing. The test included 78 drivers, each driving a test car as if they owned it for four weeks. The test covered 133 000 km, 2 500 h, and 9 600 trips (values are rounded). Driving data, system data, and environment data were collected at all times. Road type was recorded: local road, minor surface road, major surface road, ramps, freeways, and unknown. This data set is very hard, in that all values are measured. The negative side is that it only covers drivers based in southeast Michigan.

Based on this, the average speed over the tested population and all road types is 65 km/h, and the standard deviation is 35 km/h. The upper bound for the population is then shown to 100 km/h, using a 1- sigma boundary. For a normal distribution, 84 % of all driving would be at a speed of 100 km/h or less.

This is the justification for proposing that V_{max} is at least 100 km/h.

A.4 Reference data on global speed distribution of rear-end collisions

A.4.1 USA

The US data are based on a report by the John A. Volpe National Transportation Systems Research Center of the US Department of Transportation. It is based on US light vehicle data from 2003 and heavy vehicle data from 2000 to 2003¹⁾.

Because cars do not report out their speed just before collision, it is difficult for the police to directly determine the speed of a rear-end collision. In this report the speed limit is used as an indication of SV speed prior to collision. The study also identified that SVs were speeding in at least 19 % and at most 60 % of the collisions in the database. Therefore the true speeds are somewhat higher than as shown, in general. Note that in the US data, more than 80 % of the rear-end collisions occur with SV speeds below 55 mph (88 km/h). For stopped-in-path lead vehicle, nearly 10 % occur with closing velocity between 88 and 111 km/h.

In the USA, 80 % of the rear-end collisions occur at speeds of 80 km/h or less. In Japan 80 % of rear-end collisions occur at 40 km/h or less. Statistics in the European Union, United Kingdom, and Canada are thought to be more like those in the USA than in Japan. This tends to justify the need for FVCMS systems with a wide range of provided capabilities.

Table A.2 — Speed data of light vehicle rear-end collision base scenarios

| | | SV changes lanes; LV is stopped in new lane (5,1) | SV overtaking a slower LV (13,5) | SV overtaking a decelerating LV (52,9) | SV encounters a stopped lead vehicle in-path (24,6) |
|-------------|--------------|---|----------------------------------|--|---|
| Speed (mph) | Speed (km/h) | Speed limit | Speed limit | Speed limit | Speed limit |
| | | Cumulative % | Cumulative % | Cumulative % | Cumulative % |
| <25 | <40 | 8 | 9 | 9 | 8 |
| 30 | 48 | 17 | 16 | 17 | 17 |
| 35 | 55 | 42 | 36 | 41 | 43 |
| 40 | 64 | 53 | 46 | 54 | 56 |
| 45 | 72 | 74 | 64 | 76 | 77 |
| 50 | 80 | 80 | 69 | 82 | 81 |
| 55 | 88 | 88 | 82 | 93 | 91 |
| 60 | 95 | 91 | 88 | 95 | 93 |
| 65 | 104 | 97 | 97 | 98 | 99 |
| >70 | >111 | 100 | 100 | 100 | 100 |

A.4.2 Canada

2006 collision data for rear-end collisions by posted speed limit and collision severity is provided below.

Table A.3 — Cumulative proportion of rear-end collisions by posted speed limits and collision severity

| Posted Speed Limit [km/h] | Fatal Collision | Non-Fatal Injury Collision | Property Damage Only Collision | All Collision Severities |
|---------------------------|-----------------|----------------------------|--------------------------------|--------------------------|
| 10 | 0 | 0 | 0 | 0 |

1) Development of Crash Imminent Test Scenarios for Integrated Vehicle-Based Safety Systems (IVBSS), DOT HS 810 757, April 2007. Wassim G. Najm and John D. Smith, Us Department of Transportation, Research and Innovative Technology Administration, John A. Volpe National Transportation Systems Center, Cambridge, MA USA.

| | | | | |
|---------|-----|-----|-----|-----|
| 20 | 0 | 0 | 0 | 0 |
| 30 | 0 | 4 | 3 | 3 |
| 40 | 2 | 5 | 4 | 4 |
| 50 | 15 | 54 | 25 | 32 |
| 60 | 20 | 69 | 35 | 44 |
| 70 | 22 | 76 | 37 | 47 |
| 80 | 33 | 82 | 41 | 51 |
| 90 | 46 | 86 | 43 | 53 |
| 100 | 96 | 94 | 47 | 59 |
| 110 | 100 | 94 | 47 | 59 |
| Unknown | 100 | 100 | 100 | 100 |

Canadian National Collision Database 2006.

Table A.4 — Cumulative proportion of rear-end collisions by posted speed limits and collision severity (collisions with known speed limits only)

| Posted Speed Limit [km/h] | Fatal Collision | Non-Fatal Injury Collision | Property Damage Only Collision | All Collision Severities |
|---------------------------|-----------------|----------------------------|--------------------------------|--------------------------|
| 10 | 0 | 0 | 0 | 0 |
| 20 | 0 | 0 | 0 | 0 |
| 30 | 0 | 4 | 6 | 6 |
| 40 | 2 | 6 | 9 | 7 |
| 50 | 15 | 57 | 54 | 55 |
| 60 | 20 | 74 | 75 | 74 |
| 70 | 22 | 80 | 80 | 80 |
| 80 | 33 | 86 | 88 | 87 |
| 90 | 46 | 91 | 91 | 91 |
| 100 | 96 | 100 | 100 | 100 |
| 110 | 100 | 100 | 100 | 100 |

Canadian National Collision Database 2006.

A.4.3 Japan

Table A.5 is based on data presented by Japan after the Portland meeting, taken from a report by the Japanese safety agency ITARDA. The speeds are based on police accident reports. This may represent a national data collection.

Table A.5 — Japanese ITARDA report data

| Speed [km/h] | Cumulative % |
|--------------|--------------|
| 0 | 0 |
| 10 | 22 |
| 20 | 42 |

| | |
|----|----|
| 30 | 62 |
| 40 | 80 |
| 50 | 93 |
| 60 | 97 |
| 70 | 98 |

A.5 Vehicle classifications

The United Nations Economic and Social Council World Forum for Harmonization of Vehicle Regulations (WP.29) TRANS/WP.29/1045 has assessed the ways the US, Europe, and Asia classify vehicles. This classification has been used in this International Standard. The document can currently be found at: <http://www.unece.org/trans/main/wp29/wp29wgs/wp29gen/wp29classification.html>.

A.6 Derivation of ETTC

The formula for ETTC is derived assuming the relative acceleration between the SV and TV remains constant. Using rectilinear kinematics of a particle, position can be expressed as a function of time.

$$\int_{x_0}^X dx = \int_0^t (v_0 + a_c t) dt$$

Assuming Constant Acceleration

$$x = x_0 + v_0 t + \frac{1}{2} a_c t^2$$

Solving using the quadratic equation

$$0 = x_c + (v_{TV} - v_{SV})t + \frac{1}{2}(a_{TV} - a_{SV})t^2$$

$$t = \frac{\left[-(v_{TV} - v_{SV}) \pm \sqrt{(v_{TV} - v_{SV})^2 - 4 * \left[\frac{1}{2}(a_{TV} - a_{SV}) \right] * x_c} \right]}{2 * \left[\frac{1}{2}(a_{TV} - a_{SV}) \right]}$$

$$\therefore ETTC = \frac{\left[-(v_{TV} - v_{SV}) \pm \sqrt{(v_{TV} - v_{SV})^2 - 2 * (a_{TV} - a_{SV}) * x_c} \right]}{(a_{TV} - a_{SV})}$$

A.7 Relationship between ACC (ISO 15622), FSRA (ISO 22179), and FVCMS

The differences identify that FVCMS Type 2 and 3 should not be confused by the driver with ACC. It is possible as well for a manufacturer to provide both capabilities in an integrated system, because there are no conflicts between their operations. If FVCMS recognizes a hazard while under ACC control, it delivers a Collision Warning before starting mitigation braking. This signifies to the driver that ACC is no longer in control, and that there is a major imminent emergency.

Table A.6 — Performance differences between ACC and FVCMS

| Performance Feature | ACC | FSRA | FVCMS |
|--|--|---|---|
| Essential benefit to driver | Actuate throttle and brake to control speed and gap to lead vehicle. | Actuate throttle and brake to control speed and gap to lead vehicle. | Actuate the brake to reduce damage and potential for injury in case of rear-end collision threat. |
| Braking preceded by a warning | Not required | Not required | Required |
| Criterion for activation | Driver control or automatic transition from off to Standby. Transition to Active based on speed and clutch position. | Driver control or automatic transition from off to Standby. Transition to Active based on speed and clutch position. | Automatic transition to Inactive. Transition to Active based on speed. |
| Method of providing deceleration | Throttle control and brake control. | Throttle control and brake control. | Brake control. |
| Constraints on braking level for deceleration | Maximum deceleration $3,5 \text{ m/s}^2$ (averaged over 2 sec). Maximum jerk $2,5 \text{ m/s}^3$ (averaged over 1 sec). | Deceleration limits based on vehicle speed. Jerk limits based on vehicle speed. | Maximum deceleration not constrained. Minimum deceleration capability of 5 m/s^2 required for light vehicles. Maximum jerk not constrained. |
| Limits on subject vehicle operating speed | Cannot accelerate below 5 m/s. Cannot set speed below 7 m/s. Upper limit set by manufacturer. | Capable of accelerating from stop with driver authority. Cannot set speed below 7 m/s. Upper limit set by manufacturer. | Not required to provide mitigation braking below 4,2 m/s. Upper limit set by manufacturer. |
| Driver deactivation of braking for deceleration | Required | Required | Required |
| Deactivation of braking for deceleration if braking criterion is no longer met | Required | Required | Required |
| Track stopping lead vehicle to full stop | Not required | Required | Required |

Bibliography

- [1] ISO 1176, *Road vehicles — Masses — Vocabulary and codes*
- [2] ISO 3833, *Road vehicles — Types — Terms and definitions*
- [3] ISO 6161:1981, *Personal eye-protectors — Filters and eye-protectors against laser radiation*
- [4] ECE Regulation No. 13-H, *Uniform provisions concerning the approval of passenger cars with regard to braking*
- [5] IEC 60825-1:2001, *Safety of laser products — Part 1: Equipment classification, requirements and user's guide (consolidated edition)*

British Standards Institution (BSI)

BSI is the independent national body responsible for preparing British Standards and other standards-related publications, information and services. It presents the UK view on standards in Europe and at the international level.

BSI is incorporated by Royal Charter. British Standards and other standardisation products are published by BSI Standards Limited.

Revisions

British Standards and PASs are periodically updated by amendment or revision. Users of British Standards and PASs should make sure that they possess the latest amendments or editions.

It is the constant aim of BSI to improve the quality of our products and services. We would be grateful if anyone finding an inaccuracy or ambiguity while using British Standards would inform the Secretary of the technical committee responsible, the identity of which can be found on the inside front cover. Similar for PASs, please notify BSI Customer Services.

Tel: +44 (0)20 8996 9001 Fax: +44 (0)20 8996 7001

BSI offers BSI Subscribing Members an individual updating service called PLUS which ensures that subscribers automatically receive the latest editions of British Standards and PASs.

Tel: +44 (0)20 8996 7669 Fax: +44 (0)20 8996 7001

Email: plus@bsigroup.com

Buying standards

You may buy PDF and hard copy versions of standards directly using a credit card from the BSI Shop on the website www.bsigroup.com/shop. In addition all orders for BSI, international and foreign standards publications can be addressed to BSI Customer Services.

Tel: +44 (0)20 8996 9001 Fax: +44 (0)20 8996 7001

Email: orders@bsigroup.com

In response to orders for international standards, BSI will supply the British Standard implementation of the relevant international standard, unless otherwise requested.

Information on standards

BSI provides a wide range of information on national, European and international standards through its Knowledge Centre.

Tel: +44 (0)20 8996 7004 Fax: +44 (0)20 8996 7005

Email: knowledgecentre@bsigroup.com

BSI Subscribing Members are kept up to date with standards developments and receive substantial discounts on the purchase price of standards. For details of these and other benefits contact Membership Administration.

Tel: +44 (0)20 8996 7002 Fax: +44 (0)20 8996 7001

Email: membership@bsigroup.com

Information regarding online access to British Standards and PASs via British Standards Online can be found at www.bsigroup.com/BSOL

Further information about British Standards is available on the BSI website at www.bsi-group.com/standards

Copyright

All the data, software and documentation set out in all British Standards and other BSI publications are the property of and copyrighted by BSI, or some person or entity that own copyright in the information used (such as the international standardisation bodies) has formally licensed such information to BSI for commercial publication and use. Except as permitted under the Copyright, Designs and Patents Act 1988 no extract may be reproduced, stored in a retrieval system or transmitted in any form or by any means – electronic, photocopying, recording or otherwise – without prior written permission from BSI. This does not preclude the free use, in the course of implementing the standard, of necessary details such as symbols, and size, type or grade designations. If these details are to be used for any other purpose than implementation then the prior written permission of BSI must be obtained. Details and advice can be obtained from the Copyright & Licensing Department.

Tel: +44 (0)20 8996 7070

Email: copyright@bsigroup.com

BSI

389 Chiswick High Road London W4 4AL UK

Tel +44 (0)20 8996 9001

Fax +44 (0)20 8996 7001

www.bsigroup.com/standards