

BS ISO 22765:2016



BSI Standards Publication

**Nuclear fuel technology —
Sintered (U,Pu)O₂ pellets —
Guidance for ceramographic
preparation for microstructure
examination**

National foreword

This British Standard is the UK implementation of ISO 22765:2016.

The UK participation in its preparation was entrusted to Technical Committee NCE/9, Nuclear fuel cycle technology.

A list of organizations represented on this committee can be obtained on request to its secretary.

This publication does not purport to include all the necessary provisions of a contract. Users are responsible for its correct application.

© The British Standards Institution 2016.
Published by BSI Standards Limited 2016

ISBN 978 0 580 84761 5

ICS 27.120.30

Compliance with a British Standard cannot confer immunity from legal obligations.

This British Standard was published under the authority of the Standards Policy and Strategy Committee on 31 December 2016.

Amendments/corrigenda issued since publication

Date	Text affected
------	---------------

**Nuclear fuel technology — Sintered
(U,Pu)O₂ pellets — Guidance for
ceramographic preparation for
microstructure examination**

*Technologie du combustible nucléaire — Pastilles (U,Pu)O₂ frittées
— Préconisations relatives à la préparation céramographique pour
examen de la microstructure*





COPYRIGHT PROTECTED DOCUMENT

© ISO 2016, Published in Switzerland

All rights reserved. Unless otherwise specified, no part of this publication may be reproduced or utilized otherwise in any form or by any means, electronic or mechanical, including photocopying, or posting on the internet or an intranet, without prior written permission. Permission can be requested from either ISO at the address below or ISO's member body in the country of the requester.

ISO copyright office
Ch. de Blandonnet 8 • CP 401
CH-1214 Vernier, Geneva, Switzerland
Tel. +41 22 749 01 11
Fax +41 22 749 09 47
copyright@iso.org
www.iso.org

Contents

	Page
Foreword	iv
1 Scope	1
2 Normative references	1
3 Terms and definitions	1
4 Principle	1
5 Description	2
6 Equipment	2
7 Reagents and resin	2
8 Operating procedure	3
8.1 Specimen cutting.....	3
8.2 Resin embedding.....	3
8.3 Rough polishing.....	3
8.4 Final polishing.....	3
9 Structure development	4
9.1 General.....	4
9.2 Development by thermal treatment.....	4
9.3 Development by chemical etching.....	4
9.4 Development by ion etching.....	5
Bibliography	7

Foreword

ISO (the International Organization for Standardization) is a worldwide federation of national standards bodies (ISO member bodies). The work of preparing International Standards is normally carried out through ISO technical committees. Each member body interested in a subject for which a technical committee has been established has the right to be represented on that committee. International organizations, governmental and non-governmental, in liaison with ISO, also take part in the work. ISO collaborates closely with the International Electrotechnical Commission (IEC) on all matters of electrotechnical standardization.

The procedures used to develop this document and those intended for its further maintenance are described in the ISO/IEC Directives, Part 1. In particular the different approval criteria needed for the different types of ISO documents should be noted. This document was drafted in accordance with the editorial rules of the ISO/IEC Directives, Part 2. www.iso.org/directives

Attention is drawn to the possibility that some of the elements of this document may be the subject of patent rights. ISO shall not be held responsible for identifying any or all such patent rights. Details of any patent rights identified during the development of the document will be in the Introduction and/or on the ISO list of patent declarations received. www.iso.org/patents

Any trade name used in this document is information given for the convenience of users and does not constitute an endorsement.

For an explanation on the meaning of ISO specific terms and expressions related to conformity assessment, as well as information about ISO's adherence to the World Trade Organization (WTO) principles in the Technical Barriers to Trade (TBT), see the following URL: <http://www.iso.org/iso/foreword.html>

The committee responsible for this document is ISO/TC 85, *Nuclear energy, nuclear technologies, and radiological protection*, Subcommittee SC 5, *Nuclear installations, processes and technologies*.

Nuclear fuel technology — Sintered (U,Pu)O₂ pellets — Guidance for ceramographic preparation for microstructure examination

1 Scope

This document describes the ceramographic procedure used to prepare sintered (U,Pu)O₂ pellets for qualitative and quantitative examination of the pellet microstructure.

The examinations are performed before and after thermal treatment or chemical etching.

They allow

- observation of any cracks, intra- and intergranular pores or inclusions, and
- measurement of the grain size, porosity and plutonium homogeneity distribution.

The mean grain diameter is measured by one of the classic methods: counting (intercept method), comparison with standard grids or typical images, etc.^[2] The measurement of individual grain sizes requires uniform development of the microstructure over the entire specimen.

The plutonium cluster and pore distribution and localization are generally analysed by automatic image analysis systems. The plutonium distribution is usually revealed by chemical etching but alpha-autoradiography can also be used. The first technique avoids the tendency for autoradiography to exaggerate the size of plutonium-rich clusters due to the distance the alpha particles travel away from the source.

2 Normative references

There are no normative references in this document.

3 Terms and definitions

No terms and definitions are listed in this document.

ISO and IEC maintain terminological databases for use in standardization at the following addresses:

- IEC Electropedia: available at <http://www.electropedia.org/>
- ISO Online browsing platform: available at <http://www.iso.org/obp>

4 Principle

The ceramographic preparation of (U,Pu)O₂ pellets involves two steps:

- specimen polishing, after embedding or not the specimen in a specific resin;
- thermal treatment or chemical etching to reveal the specimen microstructure.

5 Description

The procedure comprises the following operations:

- cutting the specimen;
- resin embedding;
- rough polishing;
- final polishing;
- thermal treatment or chemical etching.

The resin embedding operation may precede the specimen cutting operation. Resin embedding may be skipped when a mechanical device is used to hold the specimen during cutting and polishing. Thus, it is preferable to cut the pellet before embedding it.

6 Equipment

The equipment shall be installed in an environment capable of monitoring specimen containment throughout the operating sequence.

6.1 Diamond-impregnated metallography disk cutting machine with a cooling system.

6.2 Automatic polishing machine, preferably with a system for exerting constant pressure on the test specimen.

6.3 Resin preparation equipment (spoons, spatulas, PVC containers, mould).

6.4 Labware for etching.

6.5 Ultrasonic specimen cleaning tank (optional).

6.6 Optical microscope or binocular capable of at least $\times 10$.

6.7 Programmable furnace, able to reach a temperature of about 1 600 °C under argon gas sweeping.

6.8 Engraving pen.

7 Reagents and resin

7.1 Resin to be determined by the user, for example:

- liquid epoxy resin mixed with a suitable proportion of activator from the same manufacturer, curing generally occurs within 24 h at room temperature;
- polyester resin; curing occurs in 1 h.

7.2 Acid aqueous solution for the chemical etching (e.g. chrome oxide and hydrofluoric acid).

7.3 Demineralised water, complying with ISO 3696^[1].

7.4 Alcohol.

8 Operating procedure

8.1 Specimen cutting

The pellet is cut using a diamond-impregnated metallography disk-cutting machine with a cooling system, along the selected axis (longitudinal or axial).

After cutting, the specimen is cleaned in alcohol or demineralised water. An ultrasonic cleaning tank may be used.

8.2 Resin embedding

Prior to rough and final polishing, the cut specimen is embedded in resin. Therefore, the half pellet is put inside a mould with the cut face against the mould bottom.

The prepared resin, with potentially a colouring in order to distinguish the pellet Pu content, is then poured inside the mould.

After the required time (e.g. around 30 min to 60 min), the embedding pellet can be removed from the mould.

Then, the identification number of the pellet sample can be graved with the engraver pen on the resin.

The mould should be cleaned in order to reuse it.

8.3 Rough polishing

The resin-embedded specimens shall be, at first, rough-polished to eliminate any resin traces on the surface and ensure flatness. This may be done using a multi-stage process.

An example is described below:

- P180 (82 µm) abrasive disk (for specimens embedded in resin after cutting): time as necessary to reach the surface flush with the resin;
- P400 (35 µm) abrasive disk: 30 s to 1 min;
- P800 (22 µm) abrasive disk: 30 s to 1 min;
- P1200 (15 µm) abrasive disk: 30 s to 1 min;

Rough polishing is performed on a polishing machine with an air pressure of 100 kPa to 150 kPa, and at a rotation speed of 70 r/min to 270 r/min.

The specimen is thoroughly cleaned in alcohol between each step and after completion of the rough polishing operation. The cleaning may be done in an ultrasonic tank.

8.4 Final polishing

An example is described below.

The polishing operation is performed using a series of woven satin disks after injecting a diamond-paste with a grain size of 1 µm to 6 µm. Polishing is carried out for about 20 min on a polishing machine with an air pressure of 100 kPa to 200 kPa.

The specimen is thoroughly cleaned in alcohol and dried in air after polishing. The cleaning may be done in an ultrasonic tank. The polished surfaces should be mirror finished and free of scratches.

The polishing quality is checked by observing the specimen under a microscope or a binocular.

The pellets prepared in this way are suitable for examinations such as

- porosity measurements, and
- overall ceramographic examinations to reveal cracking.

9 Structure development

9.1 General

To determine the grain size, the structure should first be revealed by thermal treatment or chemical etching. Chemical etching can also be used to reveal the distribution of plutonium clusters. An alternative, to reveal the distribution of plutonium clusters, can be the alpha-autoradiography.

9.2 Development by thermal treatment

After cutting, the sample is not embedded, but placed into a mechanical device. Then, the half pellet placed in the mechanical device is polished. The polishing operation prior to the thermal treatment may be done using a multi-stage process.

An example is described below.

Rough polishing

Rough polishing is performed on a polishing machine with an air pressure of 100 kPa to 150 kPa, and at a rotation speed of 70 r/min to 270 r/min.

- P180 (82 µm) abrasive disk (for specimens embedded in resin after cutting): time as necessary to reach the surface flush with the resin
- P400 (35 µm) abrasive disk: 30 s to 1 min
- P800 (22 µm) abrasive disk: 30 s to 1 min
- P1200 (15 µm) abrasive disk: 30 s to 1 min

The specimen is thoroughly cleaned (ultrasonically or not) in alcohol between each step and after completion of the rough polishing operation.

Final polishing (see [8.4](#))

Furnace sequence

The sample is introduced into the furnace after dismounting from the mechanical device.

Thermal treatment can be carried out under various conditions. An example is described below:

- heating rate: 283 °C/h;
- fixed temperature level: 1 600 °C;
- duration: 6 h;
- scavenging with argon throughout the cycle.

The conditions are chosen to suit the furnace characteristics, the presence of other gases, gas flow and the duration of the cycle.

9.3 Development by chemical etching

The specimens are immersed for 30 s to 1 min in a reactive mixture, then rinsed in water and dried in air.

Chemical etching involves a large number of variables. The operator determines the nature of the reagent and the duration of the etching operation according to the pellet composition (Pu content, etc.) and the results obtained.

Examples:

- room-temperature etching;
- distilled water: 96 ml;
- chromium oxide Cr_2O_3 : 20 g;
- mass fraction of 40 % hydrofluoric acid: 48 ml;
- etching time: 25 s to 1 min;
- hot etching: 70 °C:
- distilled water: 24 ml;
- saturated ammonium difluoride solution: 1 ml;
- sulfuric acid (s.g. 1,84): 1 ml;
- etching time: 1 min to 5 min.

9.4 Development by ion etching

The specimen is set in a chamber of the ion etching device. An example of the device is shown in [Figure 1](#).

After evacuating air by rotary and diffusion pumps, argon gas is introduced into the chamber. Argon ions are sputtered onto the surface of the specimen by ion gun for about 10 min. The operator determines the duration of the etching operation according to the pellet composition (Pu content, etc.) and according to the results obtained.

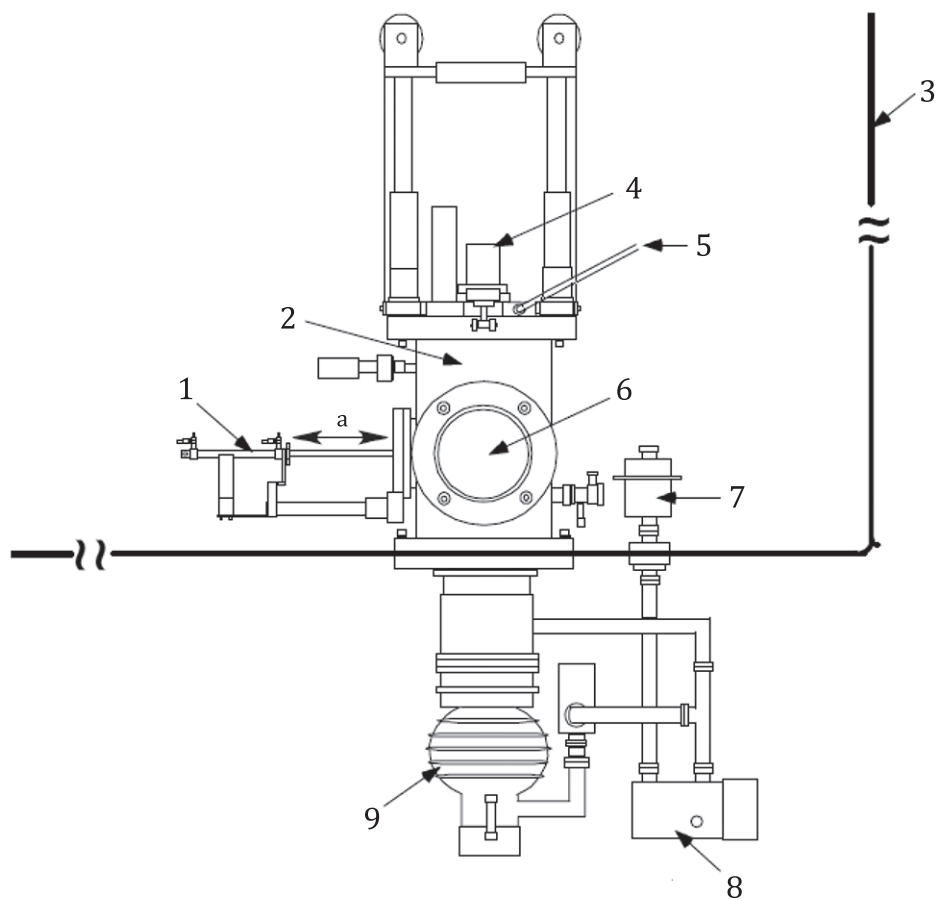

Key

- 1 sample loader
- 2 etching chamber
- 3 glove box
- 4 ion gun
- 5 argon gas inlet
- 6 observation window
- 7 oil mist filter
- 8 rotary pump
- 9 diffusion pump

a Movement of sample loader when closing and opening.

Figure 1 — Ion etching device

Bibliography

- [1] ISO 3696, *Water for analytical laboratory use — Specification and test method*
- [2] ASTM E112, *Standard test method for determining average grain size*

British Standards Institution (BSI)

BSI is the national body responsible for preparing British Standards and other standards-related publications, information and services.

BSI is incorporated by Royal Charter. British Standards and other standardization products are published by BSI Standards Limited.

About us

We bring together business, industry, government, consumers, innovators and others to shape their combined experience and expertise into standards-based solutions.

The knowledge embodied in our standards has been carefully assembled in a dependable format and refined through our open consultation process. Organizations of all sizes and across all sectors choose standards to help them achieve their goals.

Information on standards

We can provide you with the knowledge that your organization needs to succeed. Find out more about British Standards by visiting our website at bsigroup.com/standards or contacting our Customer Services team or Knowledge Centre.

Buying standards

You can buy and download PDF versions of BSI publications, including British and adopted European and international standards, through our website at bsigroup.com/shop, where hard copies can also be purchased.

If you need international and foreign standards from other Standards Development Organizations, hard copies can be ordered from our Customer Services team.

Copyright in BSI publications

All the content in BSI publications, including British Standards, is the property of and copyrighted by BSI or some person or entity that owns copyright in the information used (such as the international standardization bodies) and has formally licensed such information to BSI for commercial publication and use.

Save for the provisions below, you may not transfer, share or disseminate any portion of the standard to any other person. You may not adapt, distribute, commercially exploit, or publicly display the standard or any portion thereof in any manner whatsoever without BSI's prior written consent.

Storing and using standards

Standards purchased in soft copy format:

- A British Standard purchased in soft copy format is licensed to a sole named user for personal or internal company use only.
- The standard may be stored on more than 1 device provided that it is accessible by the sole named user only and that only 1 copy is accessed at any one time.
- A single paper copy may be printed for personal or internal company use only.

Standards purchased in hard copy format:

- A British Standard purchased in hard copy format is for personal or internal company use only.
- It may not be further reproduced – in any format – to create an additional copy. This includes scanning of the document.

If you need more than 1 copy of the document, or if you wish to share the document on an internal network, you can save money by choosing a subscription product (see 'Subscriptions').

Reproducing extracts

For permission to reproduce content from BSI publications contact the BSI Copyright & Licensing team.

Subscriptions

Our range of subscription services are designed to make using standards easier for you. For further information on our subscription products go to bsigroup.com/subscriptions.

With **British Standards Online (BSOL)** you'll have instant access to over 55,000 British and adopted European and international standards from your desktop. It's available 24/7 and is refreshed daily so you'll always be up to date.

You can keep in touch with standards developments and receive substantial discounts on the purchase price of standards, both in single copy and subscription format, by becoming a **BSI Subscribing Member**.

PLUS is an updating service exclusive to BSI Subscribing Members. You will automatically receive the latest hard copy of your standards when they're revised or replaced.

To find out more about becoming a BSI Subscribing Member and the benefits of membership, please visit bsigroup.com/shop.

With a **Multi-User Network Licence (MUNL)** you are able to host standards publications on your intranet. Licences can cover as few or as many users as you wish. With updates supplied as soon as they're available, you can be sure your documentation is current. For further information, email subscriptions@bsigroup.com.

Revisions

Our British Standards and other publications are updated by amendment or revision.

We continually improve the quality of our products and services to benefit your business. If you find an inaccuracy or ambiguity within a British Standard or other BSI publication please inform the Knowledge Centre.

Useful Contacts

Customer Services

Tel: +44 345 086 9001

Email (orders): orders@bsigroup.com

Email (enquiries): cservices@bsigroup.com

Subscriptions

Tel: +44 345 086 9001

Email: subscriptions@bsigroup.com

Knowledge Centre

Tel: +44 20 8996 7004

Email: knowledgecentre@bsigroup.com

Copyright & Licensing

Tel: +44 20 8996 7070

Email: copyright@bsigroup.com

BSI Group Headquarters

389 Chiswick High Road London W4 4AL UK