

BS ISO 22642:2015



BSI Standards Publication

Space data and information transfer systems — TC synchronization and channel coding

bsi.

...making excellence a habit.™

National foreword

This British Standard is the UK implementation of ISO 22642:2015. It supersedes BS ISO 22642:2005 which is withdrawn.

The UK participation in its preparation was entrusted to Technical Committee ACE/68, Space systems and operations.

A list of organizations represented on this committee can be obtained on request to its secretary.

This publication does not purport to include all the necessary provisions of a contract. Users are responsible for its correct application.

© The British Standards Institution 2015.
Published by BSI Standards Limited 2015

ISBN 978 0 580 89745 0

ICS 49.140

Compliance with a British Standard cannot confer immunity from legal obligations.

This British Standard was published under the authority of the Standards Policy and Strategy Committee on 31 December 2015.

Amendments/corrigenda issued since publication

Date	Text affected
------	---------------

INTERNATIONAL STANDARD

BS ISO 22642:2015

ISO
22642

Second edition
2015-11-15

Space data and information transfer systems — TC synchronization and channel coding

*Systèmes de transfert des données et informations spatiales —
Synchronisation TC et codage de canal*



Reference number
ISO 22642:2015(E)

© ISO 2015



COPYRIGHT PROTECTED DOCUMENT

© ISO 2015

All rights reserved. Unless otherwise specified, no part of this publication may be reproduced or utilized otherwise in any form or by any means, electronic or mechanical, including photocopying, or posting on the internet or an intranet, without prior written permission. Permission can be requested from either ISO at the address below or ISO's member body in the country of the requester.

ISO copyright office
Case postale 56 • CH-1211 Geneva 20
Tel. + 41 22 749 01 11
Fax + 41 22 749 09 47
E-mail copyright@iso.org
Web www.iso.org

Published in Switzerland

Foreword

ISO (the International Organization for Standardization) is a worldwide federation of national standards bodies (ISO member bodies). The work of preparing International Standards is normally carried out through ISO technical committees. Each member body interested in a subject for which a technical committee has been established has the right to be represented on that committee. International organizations, governmental and non-governmental, in liaison with ISO, also take part in the work. ISO collaborates closely with the International Electrotechnical Commission (IEC) on all matters of electrotechnical standardization.

International Standards are drafted in accordance with the rules given in the ISO/IEC Directives, Part 2.

The main task of technical committees is to prepare International Standards. Draft International Standards adopted by the technical committees are circulated to the member bodies for voting. Publication as an International Standard requires approval by at least 75 % of the member bodies casting a vote.

Attention is drawn to the possibility that some of the elements of this document may be the subject of patent rights. ISO shall not be held responsible for identifying any or all such patent rights.

This International Standard cancels and replaces ISO 22642:2005 which has been technically revised. It also incorporates ISO 22642:2005/Cor.1:1997.

ISO 22642 was prepared by the Consultative Committee for Space Data Systems (CCSDS) (as CCSDS 231.0-B-2, September 2010) and was adopted (without modifications except those stated in clause 2 of this International Standard) by Technical Committee ISO/TC 20, *Aircraft and space vehicles*, Subcommittee SC 13, *Space data and information transfer systems*.

Recommendation for Space Data System Standards

TC SYNCHRONIZATION AND CHANNEL CODING

RECOMMENDED STANDARD

CCSDS 231.0-B-2

BLUE BOOK
September 2010

AUTHORITY

Issue:	Recommended Standard, Issue 2
Date:	September 2010
Location:	

This document has been approved for publication by the Management Council of the Consultative Committee for Space Data Systems (CCSDS) and represents the consensus technical agreement of the participating CCSDS Member Agencies. The procedure for review and authorization of CCSDS documents is detailed in the *Procedures Manual for the Consultative Committee for Space Data Systems*, and the record of Agency participation in the authorization of this document can be obtained from the CCSDS Secretariat at the address below.

This document is published and maintained by:

CCSDS Secretariat
Space Communications and Navigation Office, 7L70
Space Operations Mission Directorate
NASA Headquarters
Washington, DC 20546-0001, USA

STATEMENT OF INTENT

The Consultative Committee for Space Data Systems (CCSDS) is an organization officially established by the management of its members. The Committee meets periodically to address data systems problems that are common to all participants, and to formulate sound technical solutions to these problems. Inasmuch as participation in the CCSDS is completely voluntary, the results of Committee actions are termed **Recommended Standards** and are not considered binding on any Agency.

This **Recommended Standard** is issued by, and represents the consensus of, the CCSDS members. Endorsement of this **Recommendation** is entirely voluntary. Endorsement, however, indicates the following understandings:

- o Whenever a member establishes a CCSDS-related **standard**, this **standard** will be in accord with the relevant **Recommended Standard**. Establishing such a **standard** does not preclude other provisions which a member may develop.
- o Whenever a member establishes a CCSDS-related **standard**, that member will provide other CCSDS members with the following information:
 - The **standard** itself.
 - The anticipated date of initial operational capability.
 - The anticipated duration of operational service.
- o Specific service arrangements shall be made via memoranda of agreement. Neither this **Recommended Standard** nor any ensuing **standard** is a substitute for a memorandum of agreement.

No later than five years from its date of issuance, this **Recommended Standard** will be reviewed by the CCSDS to determine whether it should: (1) remain in effect without change; (2) be changed to reflect the impact of new technologies, new requirements, or new directions; or (3) be retired or canceled.

In those instances when a new version of a **Recommended Standard** is issued, existing CCSDS-related member standards and implementations are not negated or deemed to be non-CCSDS compatible. It is the responsibility of each member to determine when such standards or implementations are to be modified. Each member is, however, strongly encouraged to direct planning for its new standards and implementations towards the later version of the Recommended Standard.

FOREWORD

This document is a technical Recommended Standard for use in developing synchronization and channel coding systems and has been prepared by the Consultative Committee for Space Data Systems (CCSDS). The synchronization and channel coding concept described herein is intended for missions that are cross-supported between Agencies of the CCSDS.

This Recommended Standard establishes a common framework and provides a common basis for the synchronization and channel coding schemes to be used by space missions with the TC Space Data Link Protocol (reference [1]) over ground-to-space and space-to-space communications links. This Recommended Standard was developed from an older CCSDS Recommended Standard (reference [C2]), which defines essentially the same schemes but in a slightly different context.

This Recommended Standard does not change the major technical content defined in reference [C2], but the presentation of the specification has been changed so that:

- a) these schemes can be used to transfer any data over any space link in either direction;
- b) all CCSDS space link protocols are specified in a unified manner;
- c) the layered model matches the Open Systems Interconnection (OSI) Basic Reference Model (reference [2]).

Together with the change in presentation, a few technical specifications in reference [C2] have been changed in order to define all Space Data Link Protocols in a unified way. Also, some technical terms in reference [C2] have been changed in order to unify the terminology used in all the CCSDS Recommended Standards that define space link protocols and to define these schemes as general communications schemes. These changes are listed in annex D of this Recommended Standard.

Through the process of normal evolution, it is expected that expansion, deletion, or modification of this document may occur. This Recommended Standard is therefore subject to CCSDS document management and change control procedures, which are defined in the *Procedures Manual for the Consultative Committee for Space Data Systems*. Current versions of CCSDS documents are maintained at the CCSDS Web site:

<http://www.ccsds.org/>

Questions relating to the contents or status of this document should be addressed to the CCSDS Secretariat at the address indicated on page i.

At time of publication, the active Member and Observer Agencies of the CCSDS were:

Member Agencies

- Agenzia Spaziale Italiana (ASI)/Italy.
- Canadian Space Agency (CSA)/Canada.
- Centre National d'Etudes Spatiales (CNES)/France.
- China National Space Administration (CNSA)/People's Republic of China.
- Deutsches Zentrum für Luft- und Raumfahrt e.V. (DLR)/Germany.
- European Space Agency (ESA)/Europe.
- Instituto Nacional de Pesquisas Espaciais (INPE)/Brazil.
- Japan Aerospace Exploration Agency (JAXA)/Japan.
- National Aeronautics and Space Administration (NASA)/USA.
- Russian Federal Space Agency (RFSA)/Russian Federation.
- UK Space Agency/United Kingdom.

Observer Agencies

- Austrian Space Agency (ASA)/Austria.
- Belgian Federal Science Policy Office (BFSPPO)/Belgium.
- Central Research Institute of Machine Building (TsNIIMash)/Russian Federation.
- China Satellite Launch and Tracking Control General, Beijing Institute of Tracking and Telecommunications Technology (CLTC/BITTT)/China.
- Chinese Academy of Sciences (CAS)/China.
- Chinese Academy of Space Technology (CAST)/China.
- Commonwealth Scientific and Industrial Research Organization (CSIRO)/Australia.
- CSIR Satellite Applications Centre (CSIR)/Republic of South Africa.
- Danish National Space Center (DNSC)/Denmark.
- Departamento de Ciência e Tecnologia Aeroespacial (DCTA)/Brazil.
- European Organization for the Exploitation of Meteorological Satellites (EUMETSAT)/Europe.
- European Telecommunications Satellite Organization (EUTELSAT)/Europe.
- Geo-Informatics and Space Technology Development Agency (GISTDA)/Thailand.
- Hellenic National Space Committee (HNSC)/Greece.
- Indian Space Research Organization (ISRO)/India.
- Institute of Space Research (IKI)/Russian Federation.
- KFKI Research Institute for Particle & Nuclear Physics (KFKI)/Hungary.
- Korea Aerospace Research Institute (KARI)/Korea.
- Ministry of Communications (MOC)/Israel.
- National Institute of Information and Communications Technology (NICT)/Japan.
- National Oceanic and Atmospheric Administration (NOAA)/USA.
- National Space Agency of the Republic of Kazakhstan (NSARK)/Kazakhstan.
- National Space Organization (NSPO)/Chinese Taipei.
- Naval Center for Space Technology (NCST)/USA.
- Scientific and Technological Research Council of Turkey (TUBITAK)/Turkey.
- Space and Upper Atmosphere Research Commission (SUPARCO)/Pakistan.
- Swedish Space Corporation (SSC)/Sweden.
- United States Geological Survey (USGS)/USA.

DOCUMENT CONTROL

Document	Title	Date	Status
CCSDS 231.0-B-1	TC Synchronization and Channel Coding, Issue 1	September 2003	Original Issue
CCSDS 231.0-B-2	TC Synchronization and Channel Coding, Recommended Standard, Issue 2	September 2010	Current issue: – adds an option for repeated transmissions of Transfer Frames (note).

NOTE – Substantive changes from the previous issue are indicated by change bars in the inside margin.

CONTENTS

<u>Section</u>	<u>Page</u>
1 INTRODUCTION.....	1-1
1.1 PURPOSE.....	1-1
1.2 SCOPE.....	1-1
1.3 APPLICABILITY.....	1-1
1.4 RATIONALE.....	1-2
1.5 DOCUMENT STRUCTURE	1-2
1.6 CONVENTIONS AND DEFINITIONS.....	1-2
1.7 REFERENCES	1-5
2 OVERVIEW	2-1
2.1 ARCHITECTURE.....	2-1
2.2 SUMMARY OF FUNCTIONS	2-1
2.3 INTERNAL ORGANIZATION OF SUBLAYER.....	2-3
3 BCH CODING	3-1
3.1 INTRODUCTION	3-1
3.2 CODEBLOCK FORMAT	3-1
3.3 ENCODING PROCEDURE.....	3-1
3.4 FILL DATA.....	3-2
3.5 DECODING PROCEDURE.....	3-3
4.1 INTRODUCTION	4-1
4.2 CLTU UNIT FORMAT.....	4-1
4.3 CLTU RECEPTION LOGIC.....	4-2
5 RANDOMIZER	5-1
5.1 INTRODUCTION	5-1
5.2 RANDOMIZER DESCRIPTION.....	5-1
5.3 APPLICATION OF THE RANDOMIZER.....	5-2
6 PHYSICAL LAYER OPERATIONS PROCEDURES.....	6-1
6.1 INTRODUCTION	6-1
6.2 DATA FORMATS	6-1
6.3 CARRIER MODULATION MODES	6-2

CONTENTS (continued)

<u>Section</u>	<u>Page</u>
6.4 PLOP-1	6-3
6.5 PLOP-2	6-4
7 MANAGED PARAMETERS	7-1
7.1 OVERVIEW OF MANAGED PARAMETERS	7-1
7.2 MANAGED PARAMETERS FOR BCH CODING	7-1
7.3 MANAGED PARAMETERS FOR CLTU	7-1
7.4 MANAGED PARAMETERS FOR THE RANDOMIZER	7-2
7.5 MANAGED PARAMETERS FOR PLOPS	7-2
ANNEX A SERVICE DEFINITION (NORMATIVE)	A-1
ANNEX B ACRONYMS AND TERMS (INFORMATIVE)	B-1
ANNEX C INFORMATIVE REFERENCES (INFORMATIVE)	C-1
ANNEX D CHANGES FROM REFERENCE [C2] (INFORMATIVE)	D-1

Figure

2-1 Relationship with OSI Layers.....	2-1
2-2 Internal Organization of the Sublayer at the Sending End	2-3
2-3 Internal Organization of the Sublayer at the Receiving End	2-4
3-1 BCH Codeblock Format	3-1
3-2 (63,56) Modified BCH Code Generator	3-2
4-1 Components of the CLTU.....	4-1
4-2 CLTU Reception State Diagram (Receiving End)	4-2
5-1 Bit Transition Generator Logic Diagram.....	5-2
6-1 Sequence of CMMs Composing PLOP-1	6-4
6-2 Sequence of CMMs Composing PLOP-2.....	6-5

Table

4-1 CLTU Reception States (Receiving End).....	4-3
4-2 CLTU Reception Events (Receiving End)	4-3
6-1 Carrier Modulation Modes	6-3
7-1 Managed Parameters for BCH Coding	7-1
7-2 Managed Parameters for CLTU.....	7-1
7-3 Managed Parameters for Randomizer.....	7-2
7-1 Managed Parameters for Repeated Transmissions	7-2
7-4 Managed Parameters for PLOPs.....	7-2
D-1 Terms That Have Been Changed from Reference [C2].....	D-2

1 INTRODUCTION

1.1 PURPOSE

The purpose of this Recommended Standard is to specify synchronization and channel coding schemes used with the Telecommand (TC) Space Data Link Protocol (reference [1]). These schemes are to be used over ground-to-space or space-to-space communications links by space missions.

1.2 SCOPE

This Recommended Standard defines synchronization and channel coding schemes in terms of:

- a) the services provided to the users of this specification;
- b) data formats; and
- c)

It does not specify:

- a) individual implementations or products;
- b) the methods or technologies required to perform the procedures; or
- c) the management activities required to configure and control the system.

1.3 APPLICABILITY

This Recommended Standard applies to the creation of Agency standards and to the future data communications over space links between CCSDS Agencies in cross-support situations. This Recommended Standard includes comprehensive specification of the data formats and procedures for inter-Agency cross support. It is neither a specification of, nor a design for, real systems that may be implemented for existing or future missions.

The Recommended Standard specified in this document is to be invoked through the normal standards programs of each CCSDS Agency, and is applicable to those missions for which cross support, based on capabilities described in this Recommended Standard, is anticipated. Where mandatory capabilities are clearly indicated in sections of this Recommended Standard, they must be implemented when this document is used as a basis for cross support. Where options are allowed or implied, implementation of these options is subject to specific bilateral cross support agreements between the Agencies involved.

1.4 RATIONALE

The CCSDS believes it is important to document the rationale underlying the recommendations chosen, so that future evaluations of proposed changes or improvements will not lose sight of previous decisions.

1.5 DOCUMENT STRUCTURE

This document is divided into seven numbered sections and four annexes:

- a) section 1 presents the purpose, scope, applicability and rationale of this Recommended Standard and lists the conventions, definitions, and references used throughout the Recommended Standard;
- b) section 2 provides an overview of synchronization and channel coding;
- c) section 3 specifies the Bose-Chaudhuri-Hocquenghem (BCH) coding;
- d) section 4 specifies the Communications Link Transmission Unit (CLTU);
- e) section 5 specifies the randomizer;
- f) section 6 specifies the Physical Layer Operations Procedures (PLOPs);
- g) section 7 lists the managed parameters associated with synchronization and channel coding;
- h) annex A defines the service provided to the users;
- i) annex B lists acronyms and terms used within this document;
- j) annex C provides a list of informative references;
- k) D lists the changes from the older CCSDS Recommended Standard (reference [C2]).

1.6 CONVENTIONS AND DEFINITIONS

1.6.1 DEFINITIONS

1.6.1.1 Definitions from the Open Systems Interconnection (OSI) Basic Reference Model

This Recommended Standard makes use of a number of terms defined in reference [2]. The use of those terms in this Recommended Standard shall be understood in a generic sense; i.e., in the sense that those terms are generally applicable to any of a variety of technologies that provide for the exchange of information between real systems. Those terms are as follows:

- a) Data Link Layer;

- b) Physical Layer;
- c) service;
- d) service data unit.

1.6.1.2 Definitions from OSI Service Definition Conventions

This Recommended Standard makes use of a number of terms defined in reference [3]. The use of those terms in this Recommended Standard shall be understood in a generic sense; i.e., in the sense that those terms are generally applicable to any of a variety of technologies that provide for the exchange of information between real systems. Those terms are as follows:

- a) indication;
- b) primitive;
- c) request;
- d) service provider;
- e) service user.

1.6.1.3 Terms Defined in This Recommended Standard

For the purposes of this Recommended Standard, the following definitions apply. Many other terms that pertain to specific items are defined in the appropriate sections.

asynchronous: not *synchronous*.

Mission Phase: a period of a mission during which specified communications characteristics are fixed. The transition between two consecutive mission phases may cause an interruption of the communications services.

Physical Channel: a stream of bits transferred over a space link in a single direction.

space link: a communications link between a spacecraft and its associated ground system or between two spacecraft. A space link consists of one or more Physical Channels in one or both directions.

1.6.2 NOMENCLATURE

The following conventions apply throughout this Recommended Standard:

- a) the words 'shall' and 'must' imply a binding and verifiable specification;
- b) the word 'should' implies an optional, but desirable, specification;
- c) the word 'may' implies an optional specification;
- d) the words 'is', 'are', and 'will' imply statements of fact.

1.6.3 CONVENTIONS

In this document, the following convention is used to identify each bit in an N-bit field. The first bit in the field to be transmitted (i.e., the most left justified when drawing a figure) is defined to be 'Bit 0'; the following bit is defined to be 'Bit 1' and so on up to 'Bit N-1'. When the field is used to express a binary value (such as a counter), the Most Significant Bit (MSB) shall be the first transmitted bit of the field, i.e., 'Bit 0' (see figure 1-1).

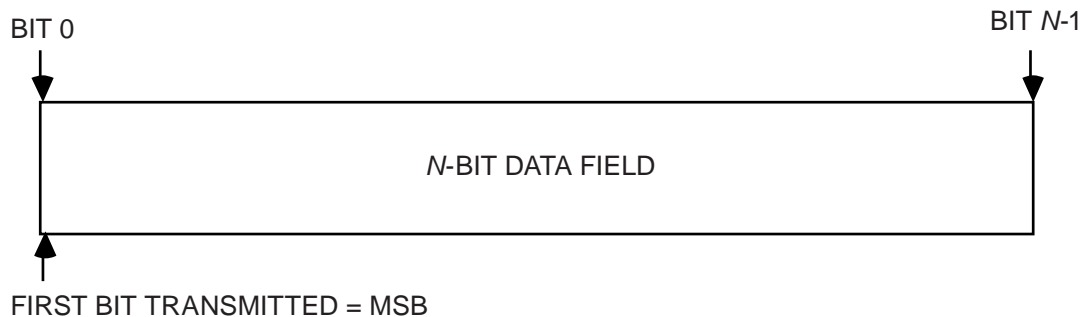

Figure 1-1: Bit Numbering Convention

In accordance with standard data-communications practice, data fields are often grouped into 8-bit 'words' which conform to the above convention. Throughout this Recommended Standard, such an 8-bit word is called an 'octet'. The numbering for octets within a data structure starts with 0. By CCSDS convention, all 'spare' bits shall be permanently set to '0'.

1.7 REFERENCES

The following documents contain provisions which, through reference in this text, constitute provisions of this Recommended Standard. At the time of publication, the editions indicated were valid. All documents are subject to revision, and users of this Recommended Standard are encouraged to investigate the possibility of applying the most recent editions of the documents indicated below. The CCSDS Secretariat maintains a register of currently valid CCSDS Recommended Standards.

- [1] *TC Space Data Link Protocol*. Recommendation for Space Data System Standards, CCSDS 232.0-B-2. Blue Book. Issue 2. Washington, D.C.: CCSDS, July 2010.
- [2] *Information Technology—Open Systems Interconnection—Basic Reference Model: The Basic Model*. International Standard, ISO/IEC 7498-1. 2nd ed. Geneva: ISO, 1994.
- [3] *Information Technology—Open Systems Interconnection—Basic Reference Model—Conventions for the definition of OSI services*. International Standard, ISO/IEC 10731:1994. Geneva: ISO, 1994.
- [4] *Radio Frequency and Modulation Systems—Part 1: Earth Stations and Spacecraft*. Recommendation for Space Data System Standards, CCSDS 401.0-B-20. Blue Book. Issue 20. Washington, D.C.: CCSDS, April 2009.
- [5] *Space Link Extension—Forward CLTU Service Specification*. Recommendation for Space Data System Standards, CCSDS 912.1-B-3. Blue Book. Issue 3. Washington, D.C.: CCSDS, July 2010.

NOTE – Informative references are listed in annex C.

2 OVERVIEW

2.1 ARCHITECTURE

Figure 2-1 illustrates the relationship of this Recommended Standard to the Open Systems Interconnection (OSI) reference model (reference [2]). Two sublayers of the Data Link Layer are defined for CCSDS space link protocols. The TC Space Data Link Protocols specified in reference [1] corresponds to the Data Link Protocol Sublayer, and provides functions for transferring data using the protocol data unit called the Transfer Frame. The Synchronization and Channel Coding Sublayer provides additional functions necessary for transferring Transfer Frames over a space link. These functions are error-control coding/decoding, delimiting/synchronizing codeblocks, and bit transition generation/removal.

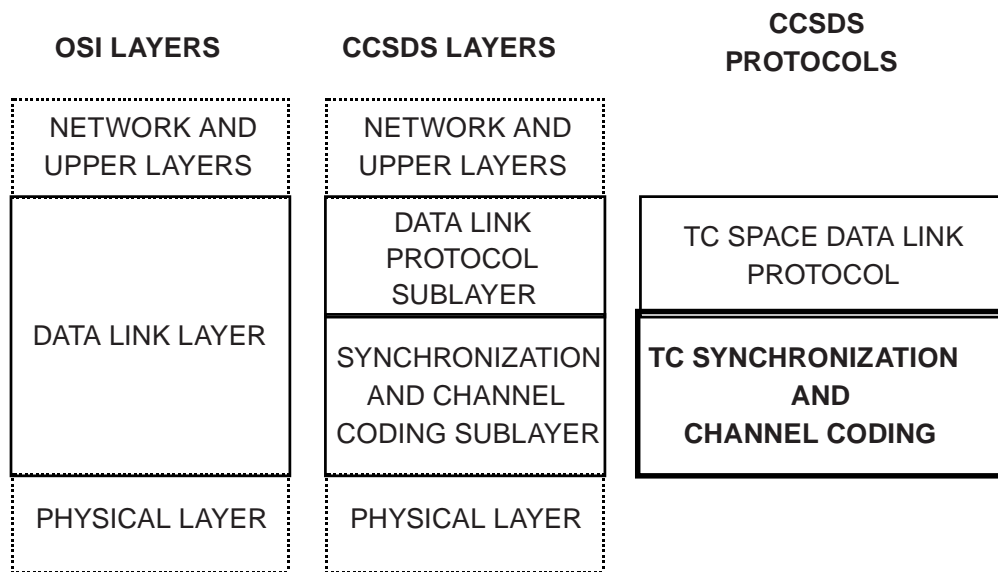

Figure 2-1: Relationship with OSI Layers

2.2 SUMMARY OF FUNCTIONS

2.2.1 FUNCTIONS

The Synchronization and Channel Coding Sublayer provides the following four functions for transferring Transfer Frames over a space link:

- a) error-control coding;
- b) synchronization;
- c) pseudo-randomizing (optional); and
- d) repeated transmissions (optional).

2.2.2 ERROR-CONTROL CODING

This Recommended Standard specifies an error-control coding method using a modified BCH code. This is described in section 3.

The modified BCH code specified in this Recommended Standard may be decoded either in an error-detecting mode or in an error-correcting mode, depending on mission requirements. If the modified BCH code is decoded in an error-detecting mode, the Frame Error Control Field (FECF) defined in reference [1] may be used to reduce the probability of undetected errors.

NOTE – In this Recommended Standard, the characteristics of the codes are specified only to the extent necessary to ensure interoperability and cross-support. The specification does not attempt to quantify the relative coding gain or the merits of each approach discussed, nor the design requirements for encoders or decoders.

2.2.3 SYNCHRONIZATION

This Recommended Standard specifies a method for synchronizing BCH Codeblocks using a data unit called the Communications Link Transmission Unit (CLTU), which consists of a Start Sequence, BCH Codeblocks, and a Tail Sequence. This is described in section 4.

The Start Sequence of the CLTU may also be used for resolution of data ambiguity (sense of '1' and '0') if data ambiguity is not resolved by the modulation method used in the Physical Layer.

This Recommended Standard also specifies a procedure called the Physical Layer Operations Procedure (PLOP) for activating and deactivating the physical communications channel so that the Physical Layer of the receiving end can achieve and maintain bit synchronization.

NOTE – Although PLOP belongs to the Physical Layer, it is included in this Recommended Standard because it must be used to transmit CLTUs specified in this document. The other specifications of the Physical Layer are contained in reference [4].

2.2.4 PSEUDO-RANDOMIZING

This Recommended Standard specifies an optional randomizer to improve bit transition density as an aid to bit synchronization. This is described in section 5.

NOTE – For brevity, the word 'random' is used in place of 'pseudo-random' throughout this document. See annex B.

2.2.5 REPEATED TRANSMISSIONS

This Recommended Standard specifies an option for repeated transmissions of Transfer Frames. Annex A contains the service definition for the user in a higher sublayer to request data transfer, including an optional Repetitions parameter for repeated transmissions. This Recommended Standard does not specify how the repeated transmissions are performed within the Synchronization and Channel Coding Sublayer. Availability of the repeated transmissions option is in accordance with parameters set by management.

2.3 INTERNAL ORGANIZATION OF SUBLAYER

2.3.1 SENDING END

Figure 2-2

At the sending end, the Synchronization and Channel Coding Sublayer accepts Transfer Frames from the Data Link Protocol Sublayer (see figure 2-1), performs functions selected for the mission, and delivers CLTUs to the Physical Layer. If necessary, fill data are added either before or after randomization to complete the integral number of BCH Codeblocks. The Physical Layer transmits CLTUs using the PLOP.

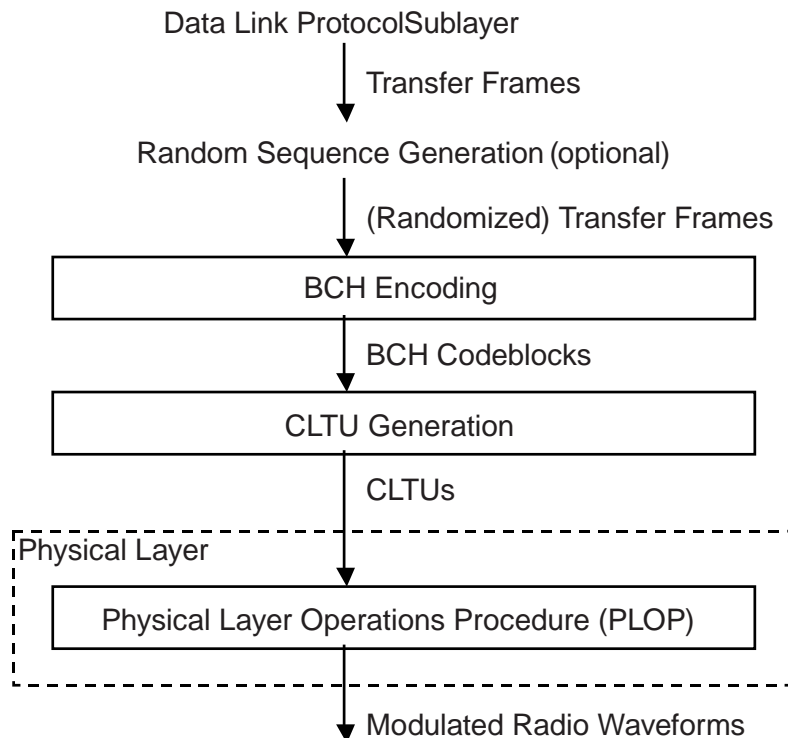

Figure 2-2: Internal Organization of the Sublayer at the Sending End

2.3.2 RECEIVING END

Figure 2-3 shows the internal organization of the Synchronization and Channel Coding Sublayer of the receiving end. This figure identifies functions performed by the sublayer and shows logical relationships among these functions. The figure is not intended to imply any hardware or software configuration in a real system.

At the receiving end, the Synchronization and Channel Coding Sublayer accepts streams of channel bits together with information on the state of the physical communications channel from the Physical Layer, performs functions selected for the mission, and delivers Transfer Frames (possibly incomplete or with fill data) to the Data Link Protocol Sublayer.

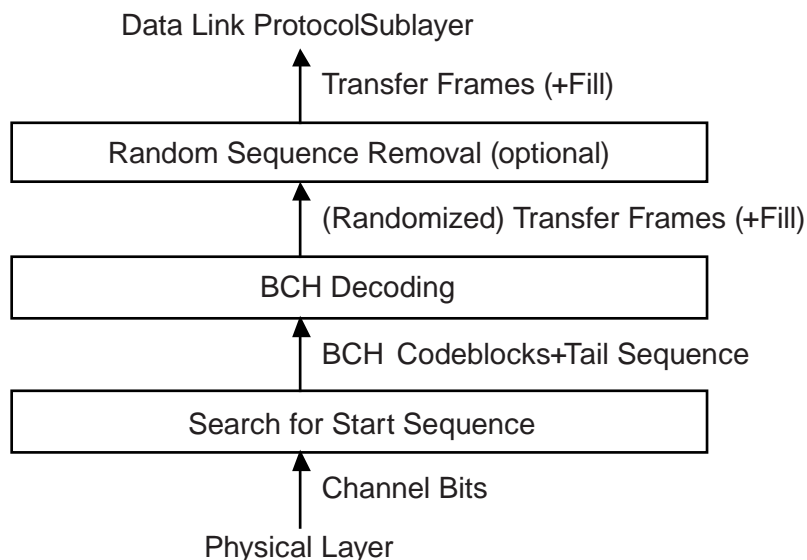

Figure 2-3: Internal Organization of the Sublayer at the Receiving End

3 BCH CODING

3.1 INTRODUCTION

The Synchronization and Channel Coding Sublayer establishes the reliable, error-controlled data channel through which user data bits may be transferred. The data are encoded to reduce the effects of noise in the Physical Layer on the user data. A modified Bose-Chaudhuri-Hocquenghem (BCH) code has been chosen to provide this protection.

3.2 CODEBLOCK FORMAT

3.2.1 The BCH Codeblock format is a fixed-length data entity shown in figure 3-1. The Codeblock is formulated using a systematic coding technique which contains 56 information bits in the leading octets, and the error control bits in the last octet. The BCH Codeblock contains an integer number of octets with an overall length of 8 octets (64 bits).

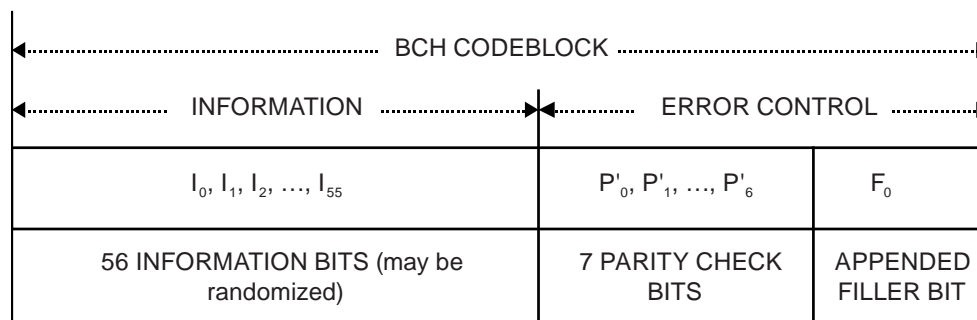

Figure 3-1: BCH Codeblock Format

3.2.2 The COMPLEMENTS of the seven parity check bits, P_0 through P_6 , are located in the first seven bits of the last octet of the BCH Codeblock. The complements are used to aid in maintaining bit synchronization and detection of bit slippage. The encoding procedure for generating these parity bits is described in 3.3.

3.2.3 The last bit of the last octet, F_0 , is a Filler Bit appended to provide an overall Codeblock length which is an integer number of octets. This Filler Bit shall always be a zero.

3.3

3.3.1 A systematic block coding procedure shall be used which always generates 7 parity check bits per Codeblock and which shall always be computed from 56 information bits. The parity check bits are then COMPLEMENTED and placed into the Codeblock as shown in figure 3-1.

3.3.2 The code used is a (63,56) modified Bose-Chaudhuri-Hocquenghem (BCH) code which uses the following generator polynomial to produce the seven parity bits:

$$g(x) = x^7 + x^6 + x^2 + 1$$

NOTE – The code generator implementation is shown in figure 3-2. The shift registers are initialized to zero. The ganged switch is in position 1 while the 56 information bits are being transmitted, in position 2 for the seven parity bits, and in position 3 for the appended Filler Bit.

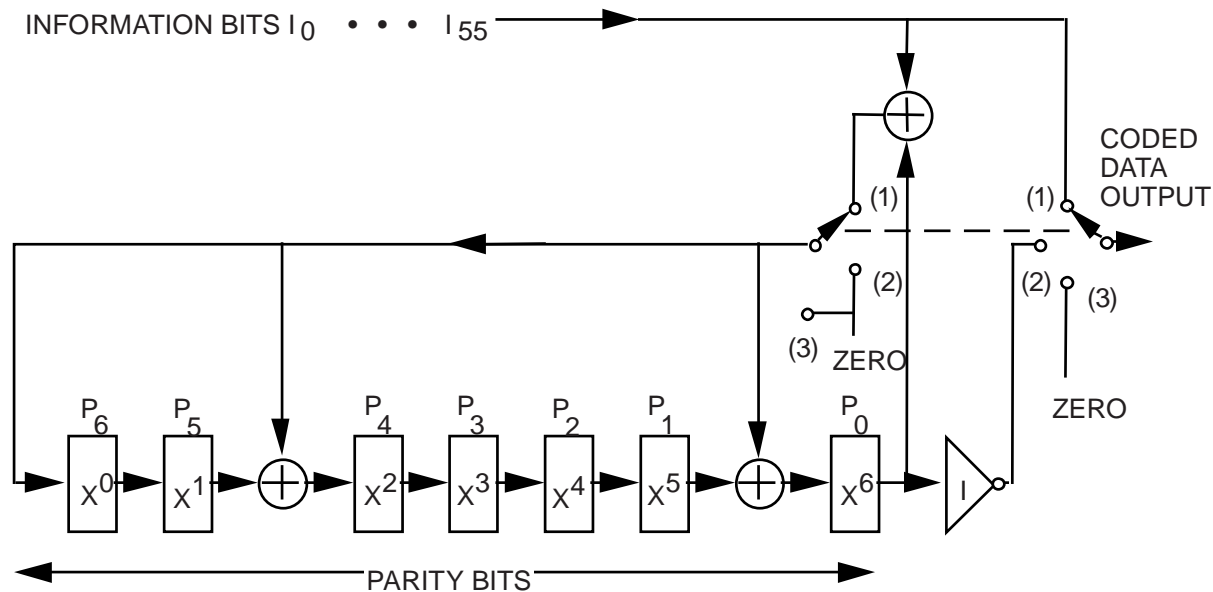

Figure 3-2: (63,56) Modified BCH Code Generator

3.4 FILL DATA

3.4.1 If the Transfer Frame(s) to be transmitted in a Communications Link Transmission Unit (CLTU) do not fit exactly within an integral number of BCH Codeblocks, then the last octet(s) and ONLY the last octet(s) of the information field of the last Codeblock within the CLTU may contain 'Fill' bits. The pattern of the fill shall consist of a sequence of alternating 'ones' and 'zeros', starting with a 'zero'.

3.4.2 The Synchronization and Channel Coding Sublayer may require the introduction of these fill data in the encoding process; they are not removed by the decoding process. Removal of fill is the responsibility of the sublayer above, which delimits the end of the Transfer Frame(s) and discards extraneous bits (e.g., fill).

3.4.3 If randomization is used, the fill data mentioned above shall be added either before or after randomization.

NOTE – If randomization is being used, any fill octets that were added to the last Codeblock of the CLTU will be derandomized even if they were not randomized.

3.5 DECODING PROCEDURE

Codeblocks that have been encoded using the modified BCH code described in 3.3 may be decoded either in an error-detecting mode (Triple Error Detection, or TED) or in an error-correcting mode (Single Error Correction, or SEC), depending on mission requirements. When the error-detecting mode is chosen, one, two or three bits in error will be detected within the Codeblock (not counting the appended Filler Bit); when the error-correcting mode is chosen, one bit in error will be corrected and two bits in error will be detected.

NOTE – The decoding procedure described in 3.5 assumes the use of a hard-limiting detector before decoding, but the use of a soft-limiting detector is not intended to be precluded.

4.2.3 ENCODED DATA

The Encoded Data field shall consist of a set of BCH Codeblocks which have been encoded in accordance with the BCH Codeblock encoding procedure. In addition to error control bits, these Codeblocks contain the Transfer frame(s), plus any fill data that were appended to meet codeblock length constraints. The Transfer Frames contained in the Encoded Data field may have been randomized before encoding, or not randomized, as selected for the mission.

4.2.4 TAIL SEQUENCE

The CLTU Tail Sequence field is a data structure which is constructed specifically to be a noncorrectable sequence which delimits the end of a CLTU by stopping the decoding process. The Tail Sequence shall have the same length as the BCH Codeblock that is being used. The Tail Sequence shall consist of leading octets having the pattern 11000101, repeated as necessary until the next-to-last octet of the Tail Sequence field is reached. The last octet completes the Tail Sequence field, and always has the pattern 01111001. Therefore, the bit pattern for the standard Tail Sequence may be described as follows:

Tail Sequence Pattern

11000101 11000101 11000101 11000101 11000101 11000101 11000101 01111001

NOTE – A pattern of alternating ‘zeros’ and ‘ones’ identical to the Idle Sequence throughout the length of a Codeblock was defined in the first issue of reference [C2]. The new pattern introduced later and specified above is preferred for new designs because of its improved performance.

4.3 CLTU RECEPTION LOGIC

The CLTU Reception Logic at the receiving end is presented in state diagram form (figure 4-2). To support the state diagrams, a list of ‘states’ and ‘events’ is given in tables 4-1 and 4-2. There are three states and four events.

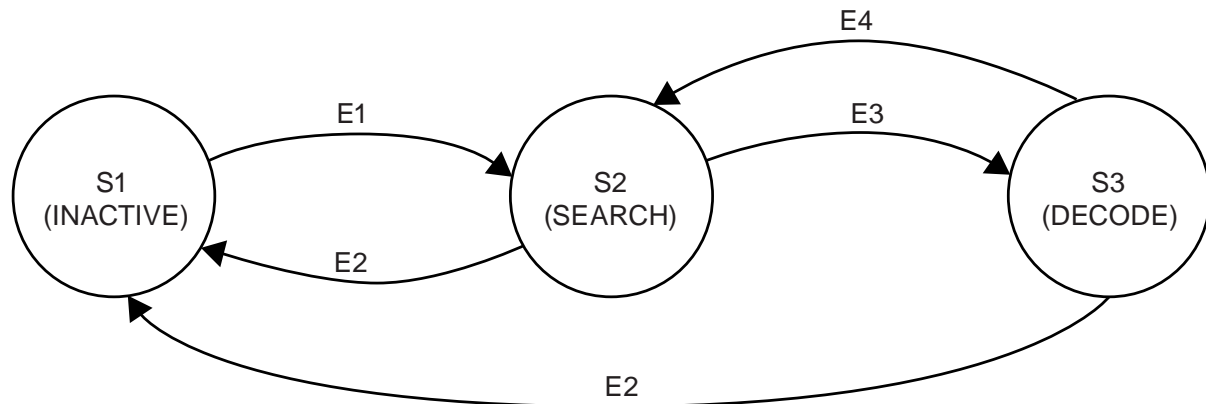

Figure 4-2: CLTU Reception State Diagram (Receiving End)

Table 4-1: CLTU Reception States (Receiving End)

State Number	State Name	State Definition
S1	INACTIVE	The communications channel is INACTIVE (i.e., 'no bit lock is achieved', or, alternatively, 'no bit modulation is detected').
S2	SEARCH	The incoming bit stream is searched, bit by bit, for the Start Sequence pattern.
S3	DECODE	BCH Codeblocks, which are either free of error or which can be corrected, are received, decoded, and derandomized (if used), and their contents are transferred to the sublayer above.

Table 4-2: CLTU Reception Events (Receiving End)

Event Number	Event Name	Event Definition
E1	CHANNEL ACTIVATION	Bit modulation is detected and bit lock is achieved: channel bit stream is present.
E2	CHANNEL DEACTIVATION	Bit lock is lost or communications signal is lost: channel bit stream is NOT present.
E3	START SEQUENCE FOUND	The Start Sequence pattern has been detected, signaling the beginning of the first Codeblock of the CLTU.
E4	CODEBLOCK REJECTION	The decoder has indicated uncorrected errors in a Codeblock. No data from this Codeblock are transferred to the sublayer above.

NOTE – In the search for the Start Sequence in State 2, no error in the Start Sequence is allowed if the modified BCH code is decoded in the error-detecting mode; one error in the Start Sequence is allowed if the modified BCH code is decoded in the error-correcting mode.

5 RANDOMIZER

5.1 INTRODUCTION

5.1.1 In order to maintain bit (or symbol) synchronization with the received communications signal, every data capture system at the receiving end requires that the incoming signal must have a minimum bit transition density (see subsection 2.2.3 in reference [4]).

5.1.2 In order to ensure proper receiver operation, the data stream must be sufficiently random. The Pseudo-Randomizer defined in this section is the preferred method to ensure sufficient randomness for all combinations of CCSDS-recommended modulation and coding schemes. The Pseudo-Randomizer defined in this section is required unless the system designer verifies proper operation of the system if this Randomizer is not used.

5.1.3 The presence or absence of randomization is fixed for a Physical Channel and is managed (i.e., its presence or absence is not signaled but must be known a priori by the receiver). A random sequence is exclusively ORed with the **Transfer Frame(s)** to increase the frequency of bit transitions. On the receiving end, the same random sequence is exclusively ORed with the decoded data, restoring the original data form. The random sequence is generated by the Bit Transition Generator (BTG).

5.2 RANDOMIZER DESCRIPTION

The random sequence shall be generated using the following polynomial:

$$h(x) = x^8 + x^6 + x^4 + x^3 + x^2 + x + 1$$

This sequence repeats after 255 bits, continuing as needed. The first 40 bits of the sequence are

1111 1111 0011 1001 1001 1110 0101 1010 0110 1000

Increasing Time----->

NOTE – Figure 5-1 depicts a basic logic diagram of the BTG.

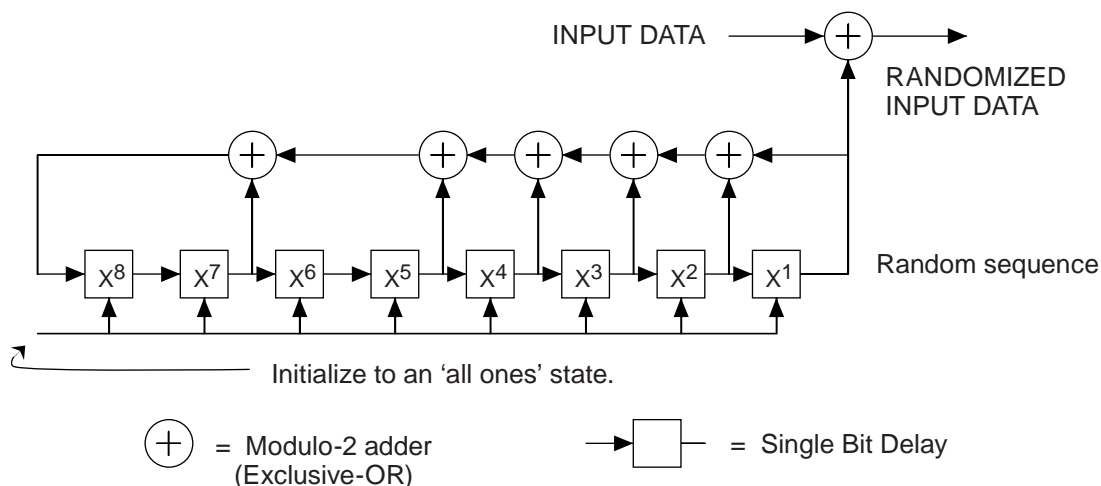

Figure 5-1: Bit Transition Generator Logic Diagram

5.3 APPLICATION OF THE RANDOMIZER

5.3.1 The randomization shall be applied at the transmitting end, and it shall be applied only to the Transfer Frame(s). The BTG shall be preset to the 'all-ones' state at the start of Transfer Frame(s) and then shall be exclusively ORed, bit by bit, with the Transfer Frame(s) until the process ends with the last bit of the Transfer Frame(s) to be transmitted in a CLTU.

5.3.2 The randomization may also be applied to the fill data added after the end of the Transfer Frame(s) to complete the last Codeblock of the CLTU, but doing so is optional.

5.3.3 At the receiving end, the derandomization shall be applied to the successfully decoded data. The BTG remains in the 'all-ones' state until the CLTU Start Sequence has been detected. The BTG pattern shall be exclusively ORed, bit by bit, to the successfully decoded data (after the Error Control Bits have been removed). The BTG shall be reset to the 'all-ones' state following a failure of the decoder to successfully decode a BCH Codeblock or other loss of data.

6 PHYSICAL LAYER OPERATIONS PROCEDURES

6.1 INTRODUCTION

6.1.1 Operations within the Physical Layer begin with the activation of the physical communications channel by invoking the radio frequency carrier and modulation techniques. These techniques include provision of any required subcarrier(s) and data modulation in order to establish the physical connection from the transmitter to the receiver. During a communications session, a series of CLTUs is transmitted to the receiver. The session ends with the removal of the carrier.

6.1.2 The Physical Layer Operations Procedures (PLOPs) specify the sequence of operations performed during a communications session. Two procedures, PLOP-1 and PLOP-2, are currently defined. The selection of PLOPs is mission-specific.

6.1.3 PLOP-2 shall be used for missions whose planning begins after September 2010.

6.1.4 PLOP-1 may still be used in ground equipment for the support of legacy missions.

6.2 DATA FORMATS

6.2.1 GENERAL

The data formats used by the PLOPs are:

- a) the Acquisition Sequence;
- b) CLTU; and
- c) the Idle Sequence.

They are used to provide synchronization of the symbol stream, and are described in 6.2.2 through 6.2.4.

6.2.2 ACQUISITION SEQUENCE

The Acquisition Sequence is a data structure forming a preamble which provides for initial symbol synchronization within the incoming stream of detected symbols. The length of the Acquisition Sequence shall be selected according to the communications link performance requirements of the mission, but the preferred minimum length is 16 octets. The length is not required to be an integral multiple of octets. The pattern of the Acquisition Sequence shall be alternating 'ones' and 'zeros', starting with either a 'one' or a 'zero'.

6.2.3 CLTU

The CLTU is the data structure (symbol sequence) furnished from the Synchronization and Channel Coding Sublayer, and defined in 4.2. It contains the data symbols that are to be transmitted to the receiving end. Each Codeblock within the CLTU, having the format specified in 3.2, shall provide at least 2 data transitions per Codeblock. If the receiver symbol synchronization design necessitates more frequent transitions, either the CLTU as delivered to the Physical Layer must have been randomized as described in section 5, or the Physical Layer must invoke a technique (modulation type, phase-coherent data and subcarrier, or other) to guarantee sufficiently frequent transitions for adequate symbol synchronization.

6.2.4 IDLE SEQUENCE

The Idle Sequence is the data structure which provides for maintenance of symbol synchronization in the absence of CLTUs. The bit pattern is a sequence of alternating ‘ones’ and ‘zeros’. The length of the Idle Sequence is an unconstrained number of bits.

NOTE – In the first issue of reference [C2], the Idle Sequence was constrained to begin with a ‘zero’ to be continuous with the CLTU Tail Sequence. Because of the improved performance of the Tail Sequence introduced later and specified in this Recommended Standard, the constraint is no longer necessary.

6.3 CARRIER MODULATION MODES

6.3.1 A PLOP consists of a sequential application of the various Carrier Modulation Modes (CMMs) in order to activate and deactivate the physical communications channel.

6.3.2 CMMs consist of different states of data modulation upon the RF carrier which creates the physical communications channel. The physical methods of modulating the carrier are described in reference [4]. The Carrier Modulation Modes are shown in table 6-1.

Table 6-1: Carrier Modulation Modes

Mode	State
CMM-1	Unmodulated CARRIER only
CMM-2	CARRIER modulated with ACQUISITION SEQUENCE
CMM-3	CARRIER modulated with CLTU
CMM-4	CARRIER modulated with IDLE SEQUENCE

6.4 PLOP-1

6.4.1 PLOP-1 is a procedure for individually radiating CLTUs, whereby the receiver is always forced into the INACTIVE state (S1) (see 4.3) by deactivating the physical communications channel after the end of transmission of each CLTU (or CLTU followed by an Idle Sequence).

6.4.2 PLOP-1 invokes the sequence of CMMs shown in figure 6-1. Note that ‘unmodulated’ is defined as the state in which no *data* modulation is present.

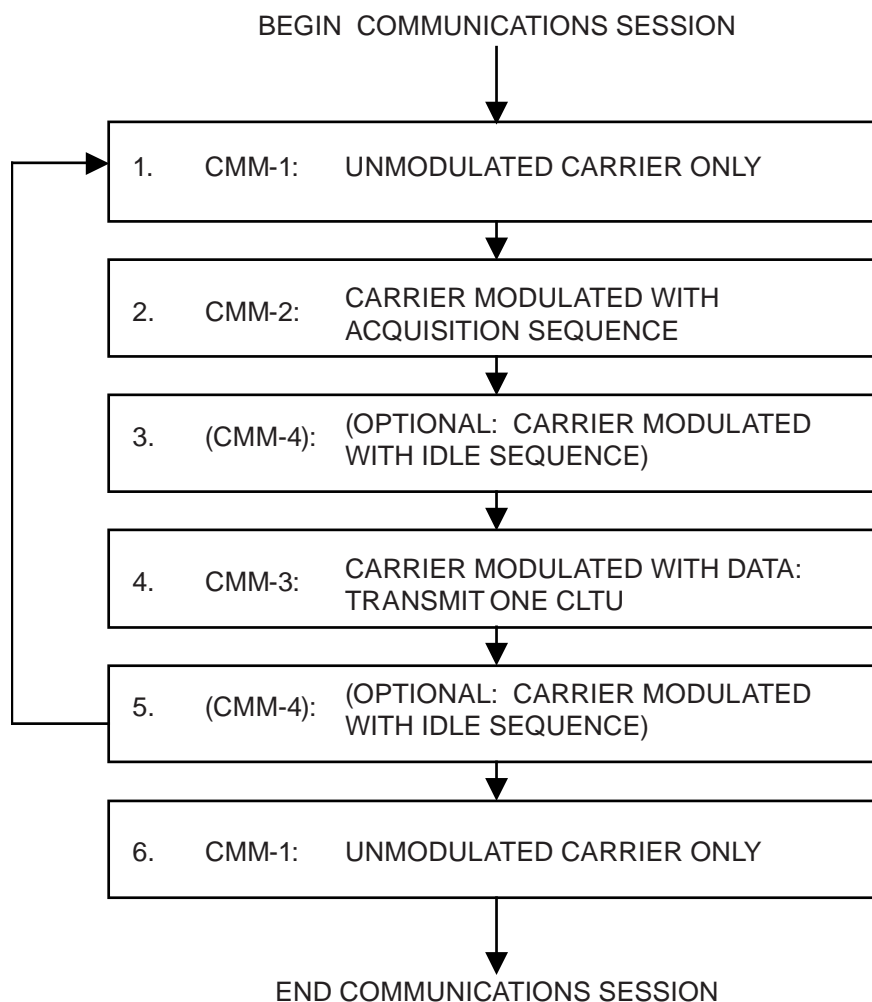

Figure 6-1: Sequence of CMMs Composing PLOP-1

6.5 PLOP-2

6.5.1 PLOP-2 is a procedure whereby the physical communications channel is not deactivated after each transmitted CLTU. The termination of an individual CLTU shall be provided only through the data path, using the CLTU Tail Sequence and, optionally, Idle Sequence. This places the receiver in the SEARCH state (S2) (see 4.3)

6.5.2 It should be noted that when operating with PLOP-2, it is recommended that a minimum Idle Sequence of one octet be systematically inserted between each CLTU to eliminate the small but finite possibility of synchronization lockout. Such a lockout may occur if the start pattern of one CLTU is not detected (leaving the receiver in SEARCH state) and a start pattern exists over the last bits of the last BCH Codeblock of that CLTU and the first bits of its Tail Sequence. This creates an erroneous but temporary CLTU start

(DECODE state), causing the true start of the following CLTU to be missed. The added Idle Sequence prevents this from happening. The CLTU transmission service specified in reference [5] includes a parameter to set the duration of the Idle Sequence following a CLTU.

6.5.3 PLOP-2 invokes the sequence of CMMs shown in figure 6-2. Note that ‘unmodulated’ is defined as the state in which no *data* modulation is present.

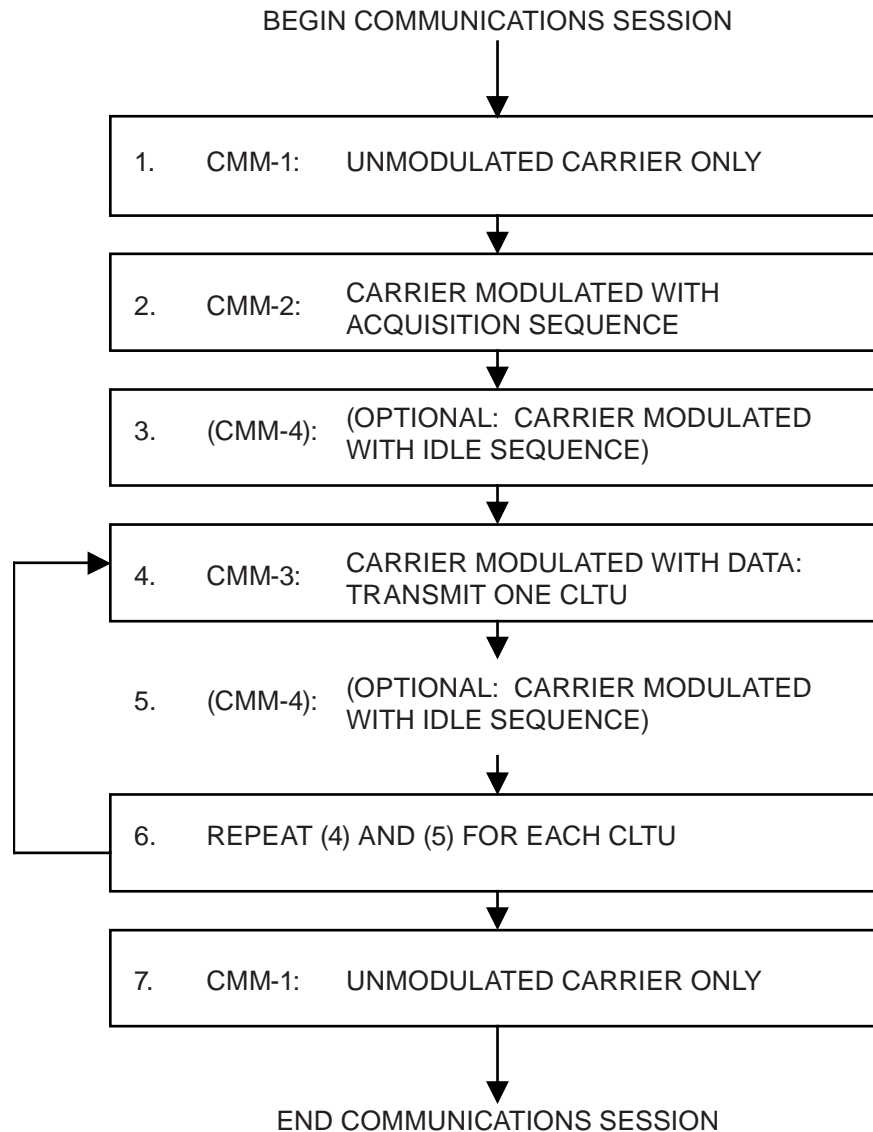

Figure 6-2: Sequence of CMMs Composing PLOP-2

7 MANAGED PARAMETERS

7.1 OVERVIEW OF MANAGED PARAMETERS

In order to conserve bandwidth on the space link, some parameters associated with synchronization and channel coding are handled by management rather than by inline communications protocol. The managed parameters are those which tend to be static for long periods of time, and whose change generally signifies a major reconfiguration of the synchronization and channel coding systems associated with a particular mission. Through the use of a management system, management conveys the required information to the synchronization and channel coding systems.

In this section, the managed parameters used by synchronization and channel coding systems are listed. These parameters are defined in an abstract sense and are not intended to imply any particular implementation of a management system.

7.2 MANAGED PARAMETERS FOR BCH CODING

Table 7-1 lists the managed parameters for BCH coding.

Table 7-1: Managed Parameters for BCH Coding

Managed Parameter	Allowed Values
Decoding Mode	Error-Detecting, Error-Correcting

7.3 MANAGED PARAMETERS FOR CLTU

Table 7-2 lists the managed parameters for CLTU.

Table 7-2: Managed Parameters for CLTU

Managed Parameter	Allowed Values
Maximum CLTU Length (octets)	Integer
Allowed Number of Errors in Start Sequence	0, 1

7.4 MANAGED PARAMETERS FOR THE RANDOMIZER

Table 7-3 lists the managed parameters for the randomizer.

Table 7-3: Managed Parameters for Randomizer

Managed Parameter	Allowed Values
Randomizer	Used, Not used

7.5 MANAGED PARAMETERS FOR REPEATED TRANSMISSIONS

Table 7-4 lists the managed parameters for repeated transmissions.

Table 7-4: Managed Parameters for Repeated Transmissions

Managed Parameter	Allowed Values
Maximum value for the Repetitions parameter (note)	Integer
NOTE – If the maximum value is 1, then the repeated transmissions option is not available.	

7.6 MANAGED PARAMETERS FOR PLOPS

Table 7-5 lists the managed parameters for PLOPs.

Table 7-5: Managed Parameters for PLOPs

Managed Parameter	Allowed Values
Physical Layer Operations Procedure	PLOP-1, PLOP-2

ANNEX A

SERVICE DEFINITION

(NORMATIVE)

A1 GENERAL

This annex provides service definition in the form of primitives, which present an abstract model of the logical exchange of data and control information between the service provider and the service user. The definitions of primitives are independent of specific implementation approaches.

The parameters of the primitives are specified in an abstract sense and specify the information to be made available to the user of the primitives. The way in which a specific implementation makes this information available is not constrained by this specification. In addition to the parameters specified in this annex, an implementation may provide other parameters to the service user (e.g., parameters for controlling the service, monitoring performance, facilitating diagnosis, and so on).

A2 OVERVIEW OF THE SERVICE

The TC Synchronization and Channel Coding provides unidirectional (one way) transfer of a sequence of variable-length TC Transfer Frames over a Physical Channel across a space link, with optional error detection/correction.

Only one user can use this service on a Physical Channel, and Transfer Frames from different users are not multiplexed together within one Physical Channel.

A3 SERVICE PARAMETERS

The parameter Frames is the service data unit of this service and, at the sending end, shall consist of one or more TC Transfer Frames defined in reference . At the receiving end, however, the parameter Frames may contain an incomplete Frame or additional fill data, which are discarded by the TC Space Data Link Protocol (reference [1]).

If the optional Repetitions parameter is supported, then the parameter shall contain a positive integer value, greater than or equal to 1. If the value of the Repetitions parameter is greater than 1, then the Frames parameter should not contain any Type-BD frames defined in reference [1].

A4 SERVICE PRIMITIVES

A4.1 GENERAL

The service primitives associated with this service are:

- a) ChannelAccess.request;
- b) ChannelAccess.indication.

The ChannelAccess.request primitive is passed from the service user at the sending end to the service provider to request that one or more Frames be transferred to the user at the receiving end through the Physical Channel.

The ChannelAccess.indication is passed from the service provider to the service user at the receiving end to deliver Frames.

A4.2 CHANNELACCESS.REQUEST

A4.2.1 Function

A4.2.2 Semantics

The ChannelAccess.request primitive shall provide one or two parameters as follows:

ChannelAccess.request (Frames, Repetitions)

NOTES

- 1 Support for the Repetitions parameter is optional.
- 2 The use of the Repetitions parameter with values greater than 1 should be restricted to links with long light time delays.
- 3 For a link with long light time delay, the use of the Repetitions parameter with a value greater than 1 can improve the probability that a sequence of frames is successfully received during a limited transmission session. Further improvement of the probability can be obtained by restricting the Frames parameter to consist of a single TC Transfer Frame: in fact, in a CLTU with multiple frames, the loss of a frame causes the loss of all subsequent frames in the same CLTU and, in addition, the probability of loss increases with the length of the CLTU.

A4.2.3 When Generated

The ChannelAccess.request primitive is passed to the service provider at the sending end to request it to process and send the Frames.

A4.2.4 Effect On Receipt

Receipt of the ChannelAccess.request primitive shall cause the service provider to perform the functions described in section 2.3.1 and to transfer the resulting CLTU. If the Repetitions parameter is supported, then the service provider shall transfer the CLTU the number of times specified by the Repetitions parameter.

NOTE – The value in the Repetitions parameter specifies the number of times the CLTU is transferred, not the additional transfers after the first one. For example, if the value of Repetitions is 3, then the service provider transfers the CLTU three times.

CHANNELACCESS.INDICATION

A4.3.1 Function

The ChannelAccess.indication primitive is the service indication primitive for this service.

A4.3.2 Semantics

The ChannelAccess.indication primitive shall provide a parameter as follows:

ChannelAccess.indication (Frames)

A4.3.3 When Generated

The ChannelAccess.indication primitive is passed from the service provider to the service user at the receiving end to deliver Frames.

A4.3.4 Effect On Receipt

The effect of receipt of the ChannelAccess.indication primitive by the service user is undefined.

ANNEX B

ACRONYMS AND TERMS

(INFORMATIVE)

This annex lists key acronyms and terms that are used throughout this Recommended Standard to describe synchronization and channel coding.

B1 ACRONYMS

BCH	Bose-Chaudhuri-Hocquenghem
BTG	Bit Transition Generator
CCSDS	Consultative Committee For Space Data Systems
CLTU	Communications Link Transmission Unit
CMM	Carrier Modulation Mode
FECF	Frame Error Control Field
MSB	Most Significant Bit
NRZ-M	Non-Return-to-Zero-Mark
PLOP	Physical Layer Operations Procedure

B2 TERMS

Acquisition Sequence: A specific high transition density bit pattern transmitted to permit the receiving end to acquire symbol synchronization.

Bit Transition Generator: A generator that produces a specific random sequence of 255 bits to be ORed with the Transfer Frame(s) to increase the frequency of bit transitions (between '1' and '0'). No additional bits are added by this process.

Carrier Modulation Mode: The mode of modulation determined by the data type being used to modulate the RF carrier or subcarrier.

Synchronization and Channel Coding Sublayer: That sublayer of the Data Link Layer used by CCSDS space link protocols which uses a prescribed coding technique to reliably transfer Transfer Frames through the potentially noisy Physical Layer.

Codeblock: A fixed-length data entity containing information and check bits that have been structured by an encoding algorithm.

Communications Link Transmission Unit: A Synchronization and Channel Coding Sublayer data entity which is used to synchronize and delimit the beginning of a continuum of bits consisting of a Start Sequence followed by an integral number of Codeblocks and a Tail Sequence.

Communications Session: A continuous period of time during which the signal path is established for the communications channel.

Data Link Layer: The layer which provides means for transferring data supplied by users (i.e., Network Layer entities) using the capability provided by the Physical Layer. It detects and possibly corrects error which may occur in the Physical Layer.

Decoding (Hard Decision): A Synchronization and Channel Coding Sublayer algorithmic process which utilizes the check bits contained in a Codeblock for detecting or correcting errors in the information bits. The check bits are then removed before the information bits are outputted.

Decoding (Soft Decision): A Synchronization and Channel Coding Sublayer algorithmic process which uses quantization of the detector output into n levels for each received bit to decide upon the most likely Codeblock and to estimate the reliability of that decision. The check bits are then removed before the best-estimate information bits and any reliability information is outputted.

Encoded Data: The data contained in a Codeblock.

Encoding: As used in this document, a Synchronization and Channel Coding Sublayer algorithmic process which adds check bits to a series of information bits to create a Codeblock.

Event: As used in this document, an action which causes the CLTU Reception Logic to change states.

Fill: Bits appended by the Synchronization and Channel Coding Sublayer to the Transfer Frame(s) to enable the data entity to exactly fit an integer number of Codeblocks. These fill data ARE transmitted and must be removed by the sublayer above. The pattern of the Fill shall consist of a sequence of alternating 'ones' and 'zeros' starting with a 'zero'.

Filler Bit: The last bit of the last octet of a BCH Codeblock to provide an overall codeblock length which is an integer number of octets. The Filler Bit shall always be a zero.

Idle Sequence: A specific high transition density bit pattern transmitted during a communications session in the absence of a CLTU to maintain symbol synchronization in the channel.

Logical Link Sublayer: That sublayer of the Data Link Layer used by CCSDS space link protocols which generates a stream of Transfer Frames from data supplied by users of the Data Link Layer.

Octet: A contiguous string of 8 bits; an 8-bit word.

Physical Layer: The lower layer of the Synchronization and Channel Coding Sublayer which provides the RF channel. At the sending end it provides the radio frequency and modulation techniques required to create and operate the channel. At the receiving end it provides the reception, demodulation, and symbol synchronization for the channel.

Physical Layer Operations Procedure: A specific procedure of the Physical Layer designed to activate and deactivate the physical communications channel by invoking RF carrier and modulation techniques.

Pseudo-Randomization: Pseudo-Randomization, herein called Randomization, is a bandwidth-efficient technique of algorithmically translating the data bits to insure frequent bit transitions in the communications channel.

Reliable: Meets the quality, quantity, continuity and completeness criteria which are specified by the communications system.

Start Sequence: A specific bit pattern at the beginning of a CLTU having a high autocorrelation function following an Idle or Acquisition Sequence and which: a) synchronizes start of a CLTU; b) delimits start of first Codeblock; and c) resolves the sense of a '1' and '0' in the CLTU, if necessary.

Symbol: A bit in an encoded data stream.

Tail Sequence: A specific data pattern which delimits the end of a CLTU.

Transfer Frame: The data unit generated by the Logical Link Sublayer of CCSDS space link protocols.

ANNEX C**INFORMATIVE REFERENCES****(INFORMATIVE)**

- [C1] *Procedures Manual for the Consultative Committee for Space Data Systems*. CCSDS A00.0-Y-9. Yellow Book. Issue 9. Washington, D.C.: CCSDS, November 2003.
- [C2] *Telecommand Part 1—Channel Service*. Recommendation for Space Data System Standards, CCSDS 201.0-B-3-S. Historical Recommendation. Issue 3-S. Washington, D.C.: CCSDS, (June 2000) August 2005.

NOTE – Normative references are listed in 1.7.

ANNEX D

CHANGES FROM REFERENCE [C2]

(INFORMATIVE)

D1 GENERAL

This Recommended Standard is developed from the specifications regarding synchronization and channel coding in older CCSDS Recommended Standard (reference [C2]), but a few technical specifications in reference [C2] have been changed in order to define all Space Data Link Protocols in a unified way. These technical changes are described in D2. Also, some technical terms in reference [C2] have been changed in order to unify the terminology used in all the CCSDS Recommended Standards that define space link protocols and to define these schemes as general communications schemes. These terminology changes are listed in D3.

D2 TECHNICAL CHANGES

D2.1 INPUT DATA

In reference [C2], it is assumed that the Synchronization and Channel Coding Sublayer accepts any data units given by the upper sublayer. In this Recommended Standard, however, it is assumed that the Synchronization and Channel Coding Sublayer only accepts Transfer Frames defined by the TC Space Data Link Protocol (reference [1]) in order to present the specifications more concretely.

D2.2 SERVICE SPECIFICATION

In reference [C2], the service specification was provided in annex B in an informal way. In this Recommended Standard, the service specification is provided in annex A using the convention defined in reference [3]. Although the format of the specification has been changed, annex A of this Recommended Standard provides essentially the same service as that of annex B of reference [C2].

D3 TERMINOLOGY CHANGES

Tables D-1 lists the terms that have been changed from reference [C2].

Table D-1: Terms That Have Been Changed from Reference [C2]

Terms Used in Reference [C2]	Terms Used in This Recommended Standard
Command Link Transmission Unit	Communications Link Transmission Unit
Encoded TC Data	Encoded Data
TC Channel Service	Channel Coding Sublayer
TC Channel Service Logic	CLTU Reception Logic
TC Codeblock	BCH Codeblock
Telecommand bit stream	Channel bit stream
Telecommand channel	Communications channel

British Standards Institution (BSI)

BSI is the national body responsible for preparing British Standards and other standards-related publications, information and services.

BSI is incorporated by Royal Charter. British Standards and other standardization products are published by BSI Standards Limited.

About us

We bring together business, industry, government, consumers, innovators and others to shape their combined experience and expertise into standards-based solutions.

The knowledge embodied in our standards has been carefully assembled in a dependable format and refined through our open consultation process. Organizations of all sizes and across all sectors choose standards to help them achieve their goals.

Information on standards

We can provide you with the knowledge that your organization needs to succeed. Find out more about British Standards by visiting our website at bsigroup.com/standards or contacting our Customer Services team or Knowledge Centre.

Buying standards

You can buy and download PDF versions of BSI publications, including British and adopted European and international standards, through our website at bsigroup.com/shop, where hard copies can also be purchased.

If you need international and foreign standards from other Standards Development Organizations, hard copies can be ordered from our Customer Services team.

Subscriptions

Our range of subscription services are designed to make using standards easier for you. For further information on our subscription products go to bsigroup.com/subscriptions.

With **British Standards Online (BSOL)** you'll have instant access to over 55,000 British and adopted European and international standards from your desktop. It's available 24/7 and is refreshed daily so you'll always be up to date.

You can keep in touch with standards developments and receive substantial discounts on the purchase price of standards, both in single copy and subscription format, by becoming a **BSI Subscribing Member**.

PLUS is an updating service exclusive to BSI Subscribing Members. You will automatically receive the latest hard copy of your standards when they're revised or replaced.

To find out more about becoming a BSI Subscribing Member and the benefits of membership, please visit bsigroup.com/shop.

With a **Multi-User Network Licence (MUNL)** you are able to host standards publications on your intranet. Licences can cover as few or as many users as you wish. With updates supplied as soon as they're available, you can be sure your documentation is current. For further information, email bsmusales@bsigroup.com.

BSI Group Headquarters

389 Chiswick High Road London W4 4AL UK

Revisions

Our British Standards and other publications are updated by amendment or revision.

We continually improve the quality of our products and services to benefit your business. If you find an inaccuracy or ambiguity within a British Standard or other BSI publication please inform the Knowledge Centre.

Copyright

All the data, software and documentation set out in all British Standards and other BSI publications are the property of and copyrighted by BSI, or some person or entity that owns copyright in the information used (such as the international standardization bodies) and has formally licensed such information to BSI for commercial publication and use. Except as permitted under the Copyright, Designs and Patents Act 1988 no extract may be reproduced, stored in a retrieval system or transmitted in any form or by any means – electronic, photocopying, recording or otherwise – without prior written permission from BSI. Details and advice can be obtained from the Copyright & Licensing Department.

Useful Contacts:

Customer Services

Tel: +44 845 086 9001

Email (orders): orders@bsigroup.com

Email (enquiries): cservices@bsigroup.com

Subscriptions

Tel: +44 845 086 9001

Email: subscriptions@bsigroup.com

Knowledge Centre

Tel: +44 20 8996 7004

Email: knowledgecentre@bsigroup.com

Copyright & Licensing

Tel: +44 20 8996 7070

Email: copyright@bsigroup.com



...making excellence a habit.™