



BSI Standards Publication

Fine ceramics (advanced ceramics, advanced technical ceramics) — Test method for air-purification performance of semiconducting photocatalytic materials —

Part 4: Removal of formaldehyde

National foreword

This British Standard is the UK implementation of ISO 22197-4:2013.

The UK participation in its preparation was entrusted to Technical Committee RPI/13, Advanced technical ceramics.

A list of organizations represented on this committee can be obtained on request to its secretary.

This publication does not purport to include all the necessary provisions of a contract. Users are responsible for its correct application.

© The British Standards Institution 2013. Published by BSI Standards Limited 2013

ISBN 978 0 580 66978 1

ICS 81.060.30

Compliance with a British Standard cannot confer immunity from legal obligations.

This British Standard was published under the authority of the Standards Policy and Strategy Committee on 30 April 2013.

Amendments issued since publication

Date	Text affected
------	---------------

**Fine ceramics (advanced ceramics,
advanced technical ceramics) —
Test method for air-purification
performance of semiconducting
photocatalytic materials —**

**Part 4:
Removal of formaldehyde**

*Céramiques techniques — Méthodes d'essai relatives à la performance
des matériaux photocatalytiques semi-conducteurs pour la
purification de l'air —*

Partie 4: Élimination du formaldéhyde





COPYRIGHT PROTECTED DOCUMENT

© ISO 2013

All rights reserved. Unless otherwise specified, no part of this publication may be reproduced or utilized otherwise in any form or by any means, electronic or mechanical, including photocopying, or posting on the internet or an intranet, without prior written permission. Permission can be requested from either ISO at the address below or ISO's member body in the country of the requester.

ISO copyright office
Case postale 56 • CH-1211 Geneva 20
Tel. + 41 22 749 01 11
Fax + 41 22 749 09 47
E-mail copyright@iso.org
Web www.iso.org

Published in Switzerland

Contents

Page

Foreword	iv
1 Scope	1
2 Normative references	1
3 Terms and definitions	1
4 Symbols	2
5 Principle	2
6 Apparatus	3
6.1 Test equipment.....	3
6.2 Test gas supply.....	5
6.3 Photoreactor.....	6
6.4 Light source.....	6
6.5 Analytical system.....	6
7 Test piece	6
8 Procedure	6
8.1 General aspects.....	6
8.2 Pretreatment of test piece.....	7
8.3 Preparation for the test.....	7
8.4 Pretest.....	8
8.5 Removal test.....	8
9 Calculation	8
10 Test method for test pieces with lower performance	9
11 Test report	9
Bibliography	10

Foreword

ISO (the International Organization for Standardization) is a worldwide federation of national standards bodies (ISO member bodies). The work of preparing International Standards is normally carried out through ISO technical committees. Each member body interested in a subject for which a technical committee has been established has the right to be represented on that committee. International organizations, governmental and non-governmental, in liaison with ISO, also take part in the work. ISO collaborates closely with the International Electrotechnical Commission (IEC) on all matters of electrotechnical standardization.

International Standards are drafted in accordance with the rules given in the ISO/IEC Directives, Part 2.

The main task of technical committees is to prepare International Standards. Draft International Standards adopted by the technical committees are circulated to the member bodies for voting. Publication as an International Standard requires approval by at least 75 % of the member bodies casting a vote.

Attention is drawn to the possibility that some of the elements of this document may be the subject of patent rights. ISO shall not be held responsible for identifying any or all such patent rights.

ISO 22197-4 was prepared by Technical Committee ISO/TC 206, *Fine ceramics*.

ISO 22197 consists of the following parts, under the general title *Fine ceramics (advanced ceramics, advanced technical ceramics) — Test method for air-purification performance of semiconducting photocatalytic materials*:

- *Part 1: Removal of nitric oxide*
- *Part 2: Removal of acetaldehyde*
- *Part 3: Removal of toluene*
- *Part 4: Removal of formaldehyde*
- *Part 5: Removal of methyl mercaptan*

Fine ceramics (advanced ceramics, advanced technical ceramics) — Test method for air-purification performance of semiconducting photocatalytic materials —

Part 4: Removal of formaldehyde

1 Scope

This part of ISO 22197 specifies a test method for the determination of the air-purification performance of materials that contain a photocatalyst or have photocatalytic films on the surface, usually made from semiconducting metal oxides, such as titanium dioxide or other ceramic materials, by continuous exposure of a test piece to the model air pollutant under illumination with ultraviolet light (UV-A). This part of ISO 22197 is intended for use with different kinds of materials, such as construction materials in flat sheet, board or plate shape, that are the basic forms of materials for various applications. This part of ISO 22197 also applies to structured filter materials including honeycomb-form, woven and non-woven fabrics, and to plastic or paper materials if they contain ceramic microcrystals and composites. This part of ISO 22197 does not apply to powder or granular photocatalytic materials.

This test method is usually applicable to photocatalytic materials produced for air purification. This method is not suitable for the determination of other performance attributes of photocatalytic materials, i.e. decomposition of water contaminants, self-cleaning, antifogging and antibacterial actions. It concerns the removal of formaldehyde.

2 Normative references

The following referenced documents are indispensable for the application of this document. For dated references, only the edition cited applies. For undated references, the latest edition of the referenced document (including any amendments) applies.

ISO 4892-3, *Plastics — Methods of exposure to laboratory light sources — Part 3: Fluorescent UV lamps*

ISO 6145-7:2001, *Gas analysis — Preparation of calibration gas mixtures using dynamic volumetric methods — Part 7: Thermal mass-flow controllers*

ISO 10677:2011, *Fine ceramics (advanced ceramics, advanced technical ceramics) — Ultraviolet light source for testing semiconducting photocatalytic materials*

ISO 16000-3:2001, *Indoor air — Part 3: Determination of formaldehyde and other carbonyl compounds — Active sampling method*

ISO/IEC 17025:2005, *General requirements for the competence of testing and calibration laboratories*

ISO 22197-1:2007, *Fine ceramics (advanced ceramics, advanced technical ceramics) — Test method for air-purification performance of semiconducting photocatalytic materials — Part 1: Removal of nitric oxide*

ISO 80000-1, *Quantities and units — Part 1: General*

3 Terms and definitions

For the purposes of this document, the following terms and definitions apply.

3.1 photocatalyst

substance that performs one or more functions based on oxidation and reduction reactions under photoirradiation, including decomposition and removal of air and water contaminants, deodorization, and antibacterial, self-cleaning and antifogging actions

3.2 photocatalytic materials

materials in which or on which the photocatalyst is added by coating, impregnation, mixing, etc

Note 1 to entry: Such photocatalytic materials are intended primarily for use as building and road construction materials to obtain the above-mentioned functions

3.3 zero-calibration gas

air that does not contain pollutants (i.e. in which common pollutants are below 0,01 µl/l)

Note 1 to entry: The zero-calibration gas is prepared from indoor air using a laboratory air purification system, or supplied as a synthetic air in a gas cylinder.

3.4 formaldehyde gas

gases of known concentrations used for test and calibration

3.5 test gas

mixture of air and pollutant(s) of known concentration prepared from a standard gas or a zero-calibration gas, to be used for the performance test of a photocatalytic material

Note 1 to entry: The flow rate, concentration, etc. are expressed at the standard state (0 °C, 101,3 kPa) and dry gas basis (exclusion of water vapour).

3.6 dark condition

test condition with no light illumination by the light source for testing and room lightings

Note 1 to entry: Usually the test gas is supplied for comparison with the illuminated reaction.

4 Symbols

For the purposes of this document, the following symbols apply.

f the flow rate of test gas converted into that at the standard state (l/min, 0 °C, 101,3 kPa, dry gas basis)

ϕ_F the volume fraction of formaldehyde at the reactor exit (µl/l)

ϕ_{F0} the supply volume fraction of formaldehyde (µl/l)

n_F the removal quantity, by test piece, of formaldehyde (µmol)

R_F the removal percentage, by test piece, of formaldehyde (%)

5 Principle

This part of ISO 22197 concerns the development, comparison, quality assurance, characterization, reliability, and design data generation of photocatalytic materials. The method described is intended to obtain the air-purification performance of photocatalytic materials by exposing a test piece to model polluted air under irradiation by ultraviolet (UV-A) light. Formaldehyde (HCHO) is chosen

because it is a typical indoor air pollutant that causes the so-called sick-building syndrome. The test piece, placed in a flow-type photoreactor, is activated by UV irradiation, and adsorbs and oxidizes gas-phase formaldehyde to form carbon dioxide (CO₂) and other oxidation products. The air purification performance is determined from the net amount of formaldehyde removed by the test piece (μmol). The simple adsorption of HCHO by the test piece (not due to photocatalysis) is evaluated by tests in the dark. However, some test pieces absorb formaldehyde very strongly, and a stable concentration of formaldehyde may not be attained in the designated time of test. The photocatalytic activity may depend on physical and chemical properties of pollutants mainly due to the adsorption process involved. For a better evaluation of air purification performance of photocatalytic materials, it is recommended to combine one or more suitable test methods as provided in other parts of ISO 22197.

6 Apparatus

6.1 Test equipment

The test equipment enables a photocatalytic material to be examined for its pollutant-removal capability by supplying the the test gas continuously, while providing photoirradiation to activate the photocatalyst. It is the same as that used in the test method for the removal of nitric oxide (ISO 22197-1) and consists of a test gas supply, a photoreactor, a light source, and pollutant-measurement equipment. Since low concentrations of pollutants are to be tested, the system shall be constructed with materials of low absorption and resistant to ultraviolet (UV) radiation, for example, acrylic resin, stainless steel, glass and fluorocarbon polymers. An example of a test system is shown in [Figure 1](#).

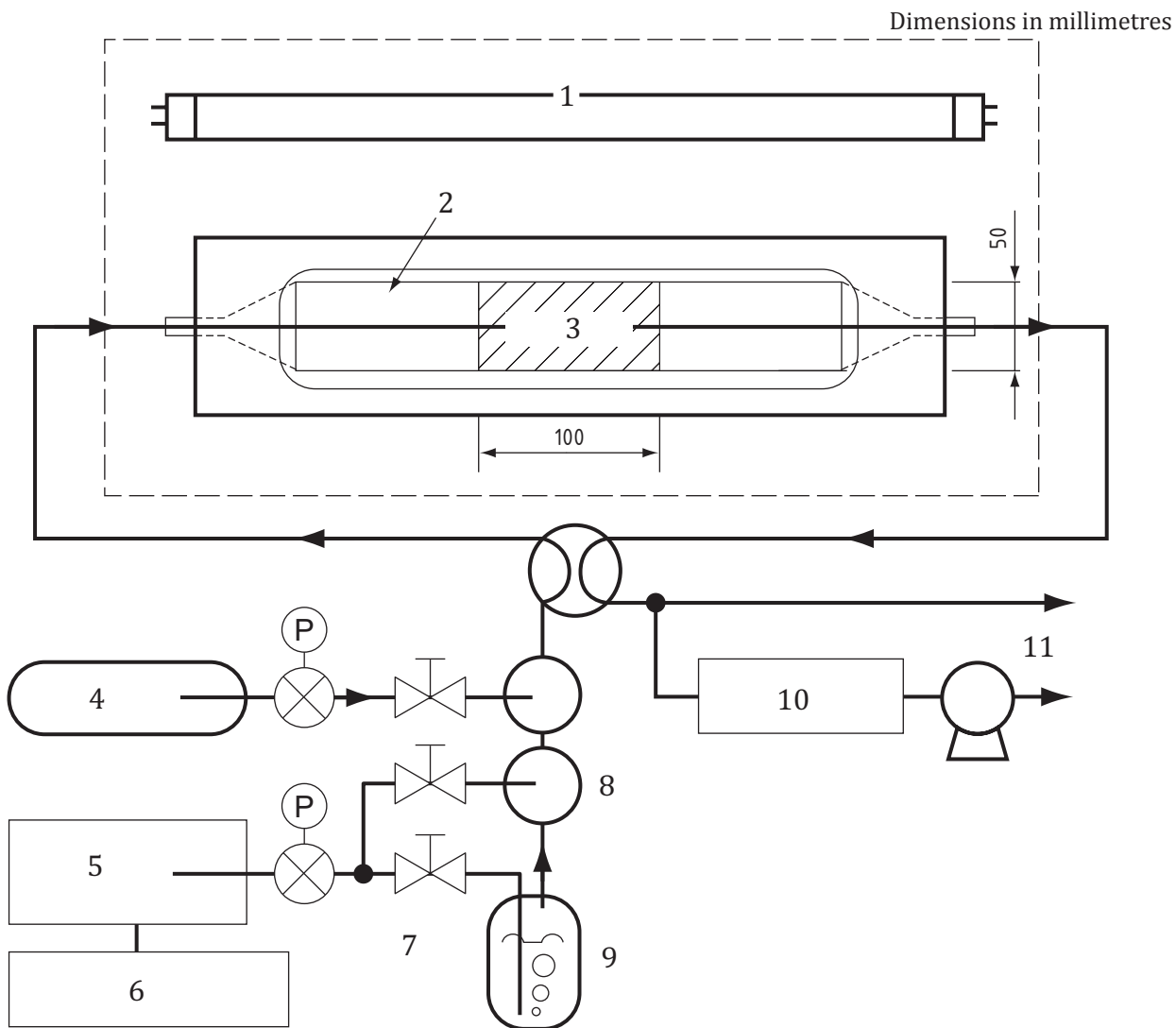

Key

- | | | | |
|---|--------------------------|----|----------------------|
| 1 | light source | 7 | mass-flow controller |
| 2 | optical window | 8 | gas mixers |
| 3 | test piece | 9 | humidifier |
| 4 | standard gas (pollutant) | 10 | analyser |
| 5 | air-purification system | 11 | vent |
| 6 | compressor | | |

Figure 1 — Schematic diagram of the test equipment

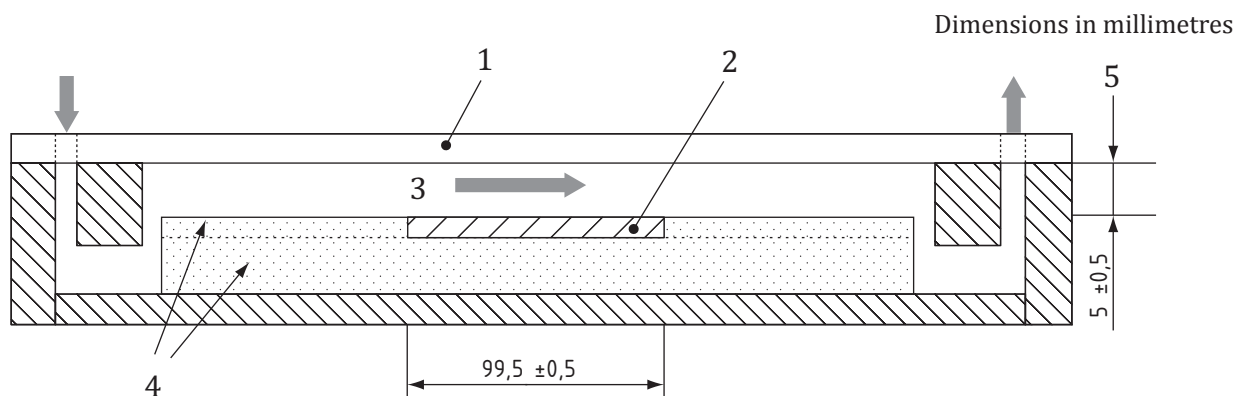

a) For flat test pieces

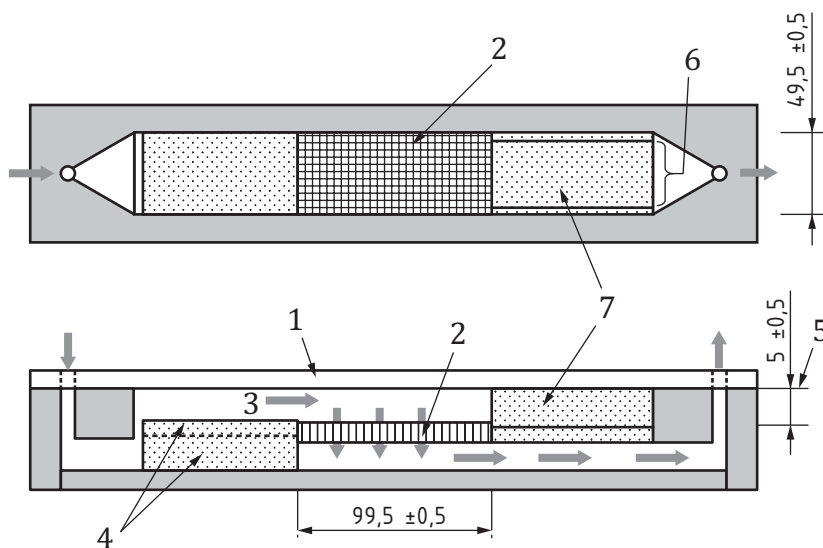

b) For filter-type test pieces

Key

- 1 window
- 2 test piece
- 3 test gas
- 4 height-adjusting plate
- 5 air layer thickness
- 6 flow channel
- 7 test piece holder

Figure 2 — Cross-sectional views of photoreactor (axial)

6.2 Test gas supply

The test gas supply provides air polluted with model contaminant at a predetermined concentration, temperature and humidity, and supplies it continuously to the photoreactor. It consists of flow regulators, a humidifier, gas mixers, etc. The flow rate of each gas should be within 5 % of the designated value,

which is easily attained by using thermal mass-flow controllers with knowledge of temperature and gas type at calibration in accordance with ISO 6145-7. The expression of gas flow rate in this part of ISO 22197 is that converted to the standard state (0 °C, 101,3 kPa and dry gas basis). Typical capacities of flow controller for pollutant gas, dry air and wet air are 200 ml/min, 2000 ml/min and 2000 ml/min, respectively. The standard formaldehyde gas in a cylinder, normally balanced with nitrogen, shall have a volume fraction of about 20 µl/l.

6.3 Photoreactor

The photoreactor holds a planar test piece within a 50 mm wide trough, with its surface parallel to an optical window for photoirradiation. The reactor shall be fabricated from materials that adsorb little test gas and withstand irradiation of near-UV light. The test piece shall be separated from the window by a 5,0 mm ± 0,5 mm thick air layer. The test gas shall pass only through the space between the test piece and the window. This gap shall be accurately set up according to the thickness of the test piece, for example by using height-adjusting plates with different thicknesses, as shown in [Figure 2 a](#)). When a filter-type material is tested, an alternative type of test-piece holder shall be used, which holds the test piece while allowing the test gas to pass through the cells of the filter under irradiation [[Figure 2 b](#)]). Quartz or borosilicate glass that absorbs minimal light at wavelengths longer than 300 nm shall be used for the window.

6.4 Light source

The light source shall provide UV-A irradiation within a wavelength range of 300 nm to 400 nm. Suitable sources include the so-called blacklight (BL) and blacklight blue (BLB) fluorescent lamps, with a maximum at 351 nm, as specified in ISO 4892-3 and ISO 10677. The test piece shall be irradiated uniformly through the window by the light source. In the case of testing honeycomb-form photocatalysts, the light source shall irradiate one face of the test piece. A light source that requires warming up shall be equipped with a shutter. The distance between the light source and the reactor shall be adjusted so that the UV irradiance (300 nm to 400 nm) at the sample surface is 10 W/m² ± 0,5 W/m². The irradiance along the length of the test piece shall also be constant within ± 5 %. The UV irradiance shall be measured with a radiometer which conforms to ISO 10677. The reactor shall be shielded from external light if necessary.

6.5 Analytical system

The test gas is sampled using a sampling cartridge, pump and flow controller, as specified in ISO 16000-3. The concentration of formaldehyde shall be determined by 2,4-dinitrophenylhydrazine-derivatised high-performance liquid chromatography (DNPH-HPLC). The reagents, equipment and procedure as specified in ISO 16000-3 shall be used. Other analytical methods that give equivalent or better performance can be used.

7 Test piece

The test piece shall be a flat material or a honeycomb filter of 49,5 mm ± 0,5 mm wide and 99,5 mm ± 0,5 mm long. It may be cut to these dimensions from a larger bulk material or coated sheet, or may be specially prepared for the test by coating a pre-cut substrate. The thickness of the test piece shall ideally be less than 5 mm, in order to minimize the contribution from the side faces. If thicker test pieces are to be tested, the side faces shall be sealed with an inert material before testing. The honeycomb test piece shall not be thicker than 20 mm.

8 Procedure

8.1 General aspects

The test procedure consists of pretreatment of the test piece, an adsorption process in the dark, and measurements of removal of formaldehyde under photoirradiation. An example of the concentration change of formaldehyde during the test is shown in [Figure 3](#). Some test pieces may not give accurate

removal of formaldehyde due to lower photocatalytic activity. In this case, loading of formaldehyde per test piece can be reduced following the procedure in [Clause 10](#).

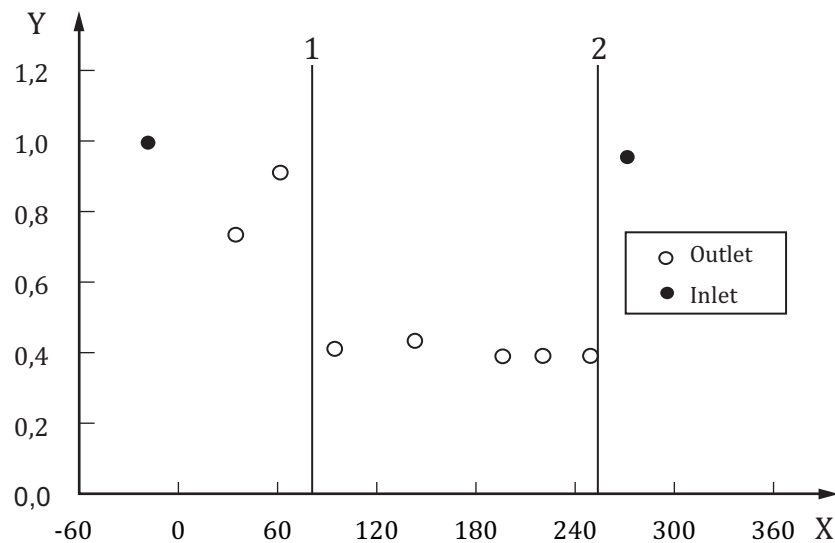

Key

- X Time (min)
- Y Concentration of formaldehyde (µl/l)
- 1 Irradiation start
- 2 Irradiation stop

Figure 3 — Typical trace of formaldehyde concentration during the test operation

8.2 Pretreatment of test piece

Irradiate the test piece with an ultraviolet lamp for at least 16 h (up to 24 h) to decompose residual organic matter on the test piece. The UV irradiance at the sample surface should be high enough to secure complete decomposition of organic matter (15 W/m² or higher). If the test pieces are not to be tested immediately after this pretreatment, they shall be kept in an airtight container.

8.3 Preparation for the test

8.3.1 Adjust the test gas supply beforehand so that it can stably supply the test gas containing $1,0 \pm 0,1$ (µl/l) of formaldehyde and $1,56 \% \pm 0,16 \%$ of volume fraction of water vapour at $25,0 \text{ }^\circ\text{C} \pm 2,5 \text{ }^\circ\text{C}$. This water-vapour volume fraction is equivalent to a relative humidity of 50 % at 25 °C. Set the flow rate to be 3,0 l/min (0 °C, 101,3 kPa, dry gas basis) at the entrance of the photoreactor. Measure and record the irradiance from the light source. For the light source that requires warming up, turn the power on well before the measurement of irradiance and irradiation for the acetaldehyde removal test. Use the shutter appropriately to avoid unnecessary irradiation to the photoreactor.

8.3.2 Place the test piece in the centre of the photoreactor and attach the glass window after adjusting the air layer between the test piece and window to be $5,0 \text{ mm} \pm 0,5 \text{ mm}$ thick. If necessary, height-adjusting plates are used for this purpose, and adjusting the height before and after of the test piece to be within 1,0 mm difference based on the top of the test piece. Check that the reactor is sealed by visual examination of the sealing material, such as an O-ring to tightly contact the glass window.

8.4 Pretest

The concentration of formaldehyde cannot be obtained instantaneously by the DNPH-HPLC method. Therefore, the time of the adsorption of formaldehyde reaching saturation in a dark condition cannot be confirmed during the test. For this reason, the following pretest shall be carried out. If the time for saturation can be confirmed during the test, there is no need for the pretest.

After pretreatment of the test piece in 8.2 and preparation for the test in 8.3, introduce the test gas into the reactor. Measure the concentration of formaldehyde under the dark condition every 15 min for 90 min. When the concentration at the outlet of the reactor becomes the same as the supply gas concentration within 30 min, then that time may be the time of the dark condition. When the concentration of formaldehyde is less than 90 % of the concentration after 30 min, the time of the dark condition shall be the time when the concentration exceeds 90 % for the first time. When the concentration of formaldehyde is still less than 90 % of the concentration after 90 min, then this part of ISO 22197 shall not apply.

8.5 Removal test

8.5.1 Follow the pretreatment procedure as in 8.2 and preparation as in 8.3.

8.5.2 If the pretest in 8.4 has been already carried out, introduce the test gas into photoreactor under dark conditions for the previously confirmed time. If the pretest has not been done yet, carry out the following procedure. Introduce the test gas into the photoreactor and record the formaldehyde concentration for 30 min under dark conditions to observe the absorption process of the test piece. If the formaldehyde concentration matches the same level of concentration of the supply concentration, at that point, initiate light irradiation. However, after 30 min and when the formaldehyde concentration is still far below 90 % of the supply concentration, continue until it exceeds 90 %. If it does not exceed 90 % even after 90 min, this test method shall not apply.

8.5.3 Maintain the gas flow and commence irradiation of the test piece. For the light source that requires warming up, the same procedure shall be applied as described in 8.3.1. Record the concentration under irradiation for 3 h. When the photocatalytic decomposition begins, the concentration decreases as in Figure 3 and eventually becomes constant. The formaldehyde concentration shall be measured at more than one point in 1 h. Measurement shall be made at more than 3 points as in the last hour (120 min – 180 min after the start of irradiation). The concentration of formaldehyde shall be obtained by the average value based on the concentrations measured in the last hour.

8.5.4 Stop the gas supply to the reactor and remove the test piece from the reactor.

NOTE When the test piece that was used in the pretest is going to be reused in the actual test, the pretreatment in 8.2 shall be repeated.

9 Calculation

The test results shall be calculated as follows. The calculated values are usually rounded to one decimal place according to ISO 80000-1. The observed concentration of formaldehyde before water vapour correction shall be used for calculation. The flow rate of test gas f is 3,0 l/min normalized for 0 °C, 101,3 kPa and dry gas basis, and is then multiplied by a factor of 1,016 for water vapour correction.

The removal percentage of formaldehyde (R_F) is calculated by Formula (1). When R_F is either below 5 % or more than 95 %, R_F is expressed as “below 5 %” or “more than 95 %”, respectively. Then, the quantity of formaldehyde removed (n_F) is calculated by Formula (2). When R_F is either below 5 % or more than 95 %, n_F is expressed as “below (0,136 $\phi_{F0} f$) μmol ” or “more than (2,585 $\phi_{F0} f$) μmol ”, respectively.

$$R_F = \frac{\phi_{F0} - \phi_F}{\phi_{F0}} \times 100 \quad (1)$$

$$n_F = R_F \times \frac{\phi_{F0} \times f \times 1,016 \times 60}{100 \times 22,4} \quad (2)$$

where

R_F is the removal percentage, by test piece, of formaldehyde (%);

n_F is the removal quantity, by test piece, of formaldehyde (μmol);

ϕ_{F0} is the supply volume fraction of formaldehyde ($\mu\text{l/l}$);

ϕ_F is volume fraction of formaldehyde at the reactor exit ($\mu\text{l/l}$);

f is the flow rate of test gas converted into that at the standard state (l/min, 0 °C, 101,3 kPa, dry gas basis).

10 Test method for test pieces with lower performance

In the case where the removal percentage is less than 5 % and a more certain result is demanded, the number of test pieces and the flow rate of test gas may be altered at the same time as shown in [Table 1](#). However, the removal quantity of formaldehyde to appear in the test report shall be half of the values calculated from Formula (2), as well as using the flow rate of 1,5 l/min. When the test conditions are altered, it is required to confirm the time of adsorption (dark condition) at the altered test conditions.

Table 1 — Alternative test conditions

Alternative test conditions	Value after change
Test gas flow rate	1,5 l/min
Number of test pieces	2 pieces

11 Test report

The test report shall include the reporting provisions of ISO/IEC 17025, and shall include the following information. Items g), h) and i) shall be reported for each test.

- a) The name and address of the testing establishment.
- b) The date of the test, a unique identification of the report and of each page, the customer's name and address, signatory of the report.
- c) A reference to this part of ISO 22197, i.e. determined in accordance with ISO 22197-4:2013.
- d) Date of test, atmospheric temperature, relative humidity, etc.
- e) Description of the test piece (material, size, shape, etc.).
- f) Description of test equipment (specifications, etc.).
- g) Test conditions (kind of pollutant gas, supply concentration, water-vapour concentration, flow rate, detailed description of light source, irradiance, analyser and radiometer used, condition of pretreatment, modification under [Clause 10](#), etc.).
- h) The amount of formaldehyde removed during the last 1 h, removal percentage of formaldehyde (optional).
- i) Any other matters of special importance, such as a change in the test piece noticed during the test.

Bibliography

- [1] ISO 4677-1:1985, *Atmospheres for conditioning and testing — Determination of relative humidity — Part 1: Aspirated psychrometer method*

British Standards Institution (BSI)

BSI is the national body responsible for preparing British Standards and other standards-related publications, information and services.

BSI is incorporated by Royal Charter. British Standards and other standardization products are published by BSI Standards Limited.

About us

We bring together business, industry, government, consumers, innovators and others to shape their combined experience and expertise into standards-based solutions.

The knowledge embodied in our standards has been carefully assembled in a dependable format and refined through our open consultation process. Organizations of all sizes and across all sectors choose standards to help them achieve their goals.

Information on standards

We can provide you with the knowledge that your organization needs to succeed. Find out more about British Standards by visiting our website at bsigroup.com/standards or contacting our Customer Services team or Knowledge Centre.

Buying standards

You can buy and download PDF versions of BSI publications, including British and adopted European and international standards, through our website at bsigroup.com/shop, where hard copies can also be purchased.

If you need international and foreign standards from other Standards Development Organizations, hard copies can be ordered from our Customer Services team.

Subscriptions

Our range of subscription services are designed to make using standards easier for you. For further information on our subscription products go to bsigroup.com/subscriptions.

With **British Standards Online (BSOL)** you'll have instant access to over 55,000 British and adopted European and international standards from your desktop. It's available 24/7 and is refreshed daily so you'll always be up to date.

You can keep in touch with standards developments and receive substantial discounts on the purchase price of standards, both in single copy and subscription format, by becoming a **BSI Subscribing Member**.

PLUS is an updating service exclusive to BSI Subscribing Members. You will automatically receive the latest hard copy of your standards when they're revised or replaced.

To find out more about becoming a BSI Subscribing Member and the benefits of membership, please visit bsigroup.com/shop.

With a **Multi-User Network Licence (MUNL)** you are able to host standards publications on your intranet. Licences can cover as few or as many users as you wish. With updates supplied as soon as they're available, you can be sure your documentation is current. For further information, email bsmusales@bsigroup.com.

BSI Group Headquarters

389 Chiswick High Road London W4 4AL UK

Revisions

Our British Standards and other publications are updated by amendment or revision.

We continually improve the quality of our products and services to benefit your business. If you find an inaccuracy or ambiguity within a British Standard or other BSI publication please inform the Knowledge Centre.

Copyright

All the data, software and documentation set out in all British Standards and other BSI publications are the property of and copyrighted by BSI, or some person or entity that owns copyright in the information used (such as the international standardization bodies) and has formally licensed such information to BSI for commercial publication and use. Except as permitted under the Copyright, Designs and Patents Act 1988 no extract may be reproduced, stored in a retrieval system or transmitted in any form or by any means – electronic, photocopying, recording or otherwise – without prior written permission from BSI. Details and advice can be obtained from the Copyright & Licensing Department.

Useful Contacts:

Customer Services

Tel: +44 845 086 9001

Email (orders): orders@bsigroup.com

Email (enquiries): cservices@bsigroup.com

Subscriptions

Tel: +44 845 086 9001

Email: subscriptions@bsigroup.com

Knowledge Centre

Tel: +44 20 8996 7004

Email: knowledgecentre@bsigroup.com

Copyright & Licensing

Tel: +44 20 8996 7070

Email: copyright@bsigroup.com



...making excellence a habit.™