



BSI Standards Publication

# **Fine ceramics (advanced ceramics, advanced technical ceramics) — Test method for air-purification performance of semiconducting photocatalytic materials**

Part 1: Removal of nitric oxide

**National foreword**

This British Standard is the UK implementation of ISO 22197-1:2016. It supersedes BS ISO 22197-1:2007 which is withdrawn.

The UK participation in its preparation was entrusted to Technical Committee RPI/13, Advanced technical ceramics.

A list of organizations represented on this committee can be obtained on request to its secretary.

This publication does not purport to include all the necessary provisions of a contract. Users are responsible for its correct application.

© The British Standards Institution 2016.  
Published by BSI Standards Limited 2016

ISBN 978 0 580 90188 1

ICS 81.060.30

**Compliance with a British Standard cannot confer immunity from legal obligations.**

This British Standard was published under the authority of the Standards Policy and Strategy Committee on 30 November 2016.

**Amendments/corrigenda issued since publication**

Date	Text affected
------	---------------

---

---

---

**Fine ceramics (advanced ceramics,  
advanced technical ceramics) —  
Test method for air-purification  
performance of semiconducting  
photocatalytic materials —**

**Part 1:  
Removal of nitric oxide**

*Céramiques techniques — Méthodes d'essai relatives à la performance  
des matériaux photocatalytiques semi-conducteurs pour la  
purification de l'air —*

*Partie 1: Élimination de l'oxyde nitrique*



**COPYRIGHT PROTECTED DOCUMENT**

© ISO 2016, Published in Switzerland

All rights reserved. Unless otherwise specified, no part of this publication may be reproduced or utilized otherwise in any form or by any means, electronic or mechanical, including photocopying, or posting on the internet or an intranet, without prior written permission. Permission can be requested from either ISO at the address below or ISO's member body in the country of the requester.

ISO copyright office  
Ch. de Blandonnet 8 • CP 401  
CH-1214 Vernier, Geneva, Switzerland  
Tel. +41 22 749 01 11  
Fax +41 22 749 09 47  
copyright@iso.org  
www.iso.org

# Contents

Page

<b>Foreword</b> .....	<b>iv</b>
<b>1 Scope</b> .....	<b>1</b>
<b>2 Normative references</b> .....	<b>1</b>
<b>3 Terms and definitions</b> .....	<b>2</b>
<b>4 Symbols</b> .....	<b>2</b>
<b>5 Principle</b> .....	<b>3</b>
<b>6 Apparatus</b> .....	<b>3</b>
6.1 Test equipment.....	3
6.2 Test gas supply.....	3
6.3 Photoreactor.....	6
6.4 Light source.....	6
6.5 Analyser of pollutants.....	6
<b>7 Test piece</b> .....	<b>6</b>
<b>8 Procedure</b> .....	<b>6</b>
8.1 Pretreatment of test piece.....	6
8.2 Pollutant-removal test.....	7
8.3 Elution test.....	8
<b>9 Calculation</b> .....	<b>8</b>
9.1 Calculation method.....	8
9.2 Amount of NO <sub>x</sub> adsorption by the test piece.....	9
9.3 Amount of NO removed by the test piece.....	9
9.4 Amount of NO <sub>2</sub> formed by the test piece.....	9
9.5 Amount of NO <sub>x</sub> desorbed from the test piece.....	10
9.6 Net amount of NO <sub>x</sub> removed by the test piece.....	10
9.7 Nitrogen eluted from the test piece.....	10
9.8 Recovery of washing with water.....	11
<b>10 Test method for test pieces with lower performance</b> .....	<b>11</b>
<b>11 Test report</b> .....	<b>11</b>
<b>Annex A (informative) Results of round-robin test</b> .....	<b>12</b>
<b>Bibliography</b> .....	<b>13</b>

## Foreword

ISO (the International Organization for Standardization) is a worldwide federation of national standards bodies (ISO member bodies). The work of preparing International Standards is normally carried out through ISO technical committees. Each member body interested in a subject for which a technical committee has been established has the right to be represented on that committee. International organizations, governmental and non-governmental, in liaison with ISO, also take part in the work. ISO collaborates closely with the International Electrotechnical Commission (IEC) on all matters of electrotechnical standardization.

The procedures used to develop this document and those intended for its further maintenance are described in the ISO/IEC Directives, Part 1. In particular the different approval criteria needed for the different types of ISO documents should be noted. This document was drafted in accordance with the editorial rules of the ISO/IEC Directives, Part 2 (see [www.iso.org/directives](http://www.iso.org/directives)).

Attention is drawn to the possibility that some of the elements of this document may be the subject of patent rights. ISO shall not be held responsible for identifying any or all such patent rights. Details of any patent rights identified during the development of the document will be in the Introduction and/or on the ISO list of patent declarations received (see [www.iso.org/patents](http://www.iso.org/patents)).

Any trade name used in this document is information given for the convenience of users and does not constitute an endorsement.

For an explanation on the meaning of ISO specific terms and expressions related to conformity assessment, as well as information about ISO's adherence to the World Trade Organization (WTO) principles in the Technical Barriers to Trade (TBT) see the following URL: [www.iso.org/iso/foreword.html](http://www.iso.org/iso/foreword.html).

The committee responsible for this document is ISO/TC 206, *Fine ceramics*.

This second edition cancels and replaces the first edition (ISO 22197-1:2007), which has been technically revised with the following changes:

- deletion of reference to ISO 4677-1 (withdrawn) from [Clause 2](#) and [8.2.2](#);
- addition of a definition of “dark condition” ([3.7](#));
- change of air-flow rate measurement to a wet gas basis (6.2);
- change of tolerance on dimensions of test piece in [Clause 7](#);
- update of procedure in [Clause 8](#) to reflect the latest knowledge;
- addition of a test method for test pieces with lower performance (new [Clause 10](#)).

A list of all parts in the ISO 22197 series can be found on the ISO website.

# Fine ceramics (advanced ceramics, advanced technical ceramics) — Test method for air-purification performance of semiconducting photocatalytic materials —

## Part 1: Removal of nitric oxide

### 1 Scope

This document specifies a test method for the determination of the air-purification performance of materials that contain a photocatalyst or have photocatalytic films on the surface, usually made from semiconducting metal oxides, such as titanium dioxide or other ceramic materials, by continuous exposure of a test piece to the model air pollutant under illumination with ultraviolet light. This document is intended for use with different kinds of materials, such as construction materials in flat sheet, board or plate shape, that are the basic forms of materials for various applications. This document also applies to materials in honeycomb-form and to plastic or paper materials if they contain ceramic microcrystals and composites. This document does not apply to powder or granular photocatalytic materials.

This test method is usually applicable to photocatalytic materials produced for air purification. This method is not suitable for the determination of other performance attributes of photocatalytic materials, i.e. decomposition of water contaminants, self-cleaning, antifogging and antibacterial actions. It concerns the removal of nitric oxide.

### 2 Normative references

The following documents are referred to in the text in such a way that some or all of their content constitutes requirements of this document. For dated references, only the edition cited applies. For undated references, the latest edition of the referenced document (including any amendments) applies.

ISO 4892-1, *Plastics — Methods of exposure to laboratory light sources — Part 1: General guidance*

ISO 4892-3, *Plastics — Methods of exposure to laboratory light sources — Part 3: Fluorescent UV lamps*

ISO 5725-2, *Accuracy (trueness and precision) of measurement methods and results — Part 2: Basic method for the determination of repeatability and reproducibility of a standard measurement method*

ISO 6145-7, *Gas analysis — Preparation of calibration gas mixtures using dynamic volumetric methods — Part 7: Thermal mass-flow controllers*

ISO 7996, *Ambient air — Determination of the mass concentration of nitrogen oxides — Chemiluminescence method*

ISO 10304-1, *Water quality — Determination of dissolved anions by liquid chromatography of ions — Part 1: Determination of bromide, chloride, fluoride, nitrate, nitrite, phosphate and sulfate*

ISO 10523, *Water quality — Determination of pH*

ISO 80000-1, *Quantities and units — Part 1: General*

ISO/IEC 17025, *General requirements for the competence of testing and calibration laboratories*

### 3 Terms and definitions

For the purposes of this document, the following terms and definitions apply.

ISO and IEC maintain terminological databases for use in standardization at the following addresses:

- IEC Electropedia: available at <http://www.electropedia.org/>
- ISO Online browsing platform: available at <http://www.iso.org/obp>

#### 3.1 photocatalyst

substance that performs one or more functions based on oxidation and reduction reactions under photoirradiation, including decomposition and removal of air and water contaminants, deodorization, and antibacterial, self-cleaning and antifogging actions

#### 3.2 photocatalytic materials

materials in which or on which the photocatalyst is added by coating, impregnation, mixing, etc.

Note 1 to entry: Such photocatalytic materials are intended primarily for use as building and road construction materials to obtain the above-mentioned functions.

#### 3.3 zero-calibration gas

air that does not contain pollutants (i.e. in which common pollutants are below 0,01 µl/l)

Note 1 to entry: The zero-calibration gas is prepared from indoor air using a laboratory air-purification system, or supplied as synthetic air in a gas cylinder.

#### 3.4 standard gas

diluted gases of known concentrations supplied in cylinders and certified by an accredited laboratory

#### 3.5 test gas

mixture of air and pollutant(s) of known concentration prepared from a standard gas or a zero-calibration gas, to be used for the performance test of a photocatalytic material

#### 3.6 purified water

water to be used for elution, etc., with a specific conductivity lower than 1 µS/cm, prepared by the ion exchange method or distillation

#### 3.7 dark condition

test condition with no light illumination by the light source for testing and room lightings

### 4 Symbols

- $f$  air-flow rate converted into that at the standard state (0 °C, 101,3 kPa) (l/min)
- $\phi_{\text{NO}}$  nitric oxide volume fraction at the reactor exit (µl/l)
- $\phi_{\text{NO}_i}$  supply volume fraction of nitric oxide (µl/l)
- $\phi_{\text{NO}_2}$  nitrogen dioxide volume fraction at the reactor exit (µl/l)
- $\phi_{\text{NO}_x}$  volume fraction of nitrogen oxides ( $\phi_{\text{NO}} + \phi_{\text{NO}_2}$ ) at the reactor exit (µl/l)



$\rho_{\text{NO}_2}$	nitrite ion concentration in the eluent from the test piece (mg/l)
$\rho_{\text{NO}_3}$	nitrate ion concentration in the eluent from the test piece (mg/l)
$t$	time of adsorption, removal or desorption operation (min)
$n_{\text{ads}}$	amount of $\text{NO}_x$ adsorbed by the test piece ( $\mu\text{mol}$ )
$n_{\text{des}}$	amount of $\text{NO}_x$ desorbed from the test piece ( $\mu\text{mol}$ )
$n_{\text{NO}}$	amount of NO removed by the test piece ( $\mu\text{mol}$ )
$n_{\text{NO}_2}$	amount of $\text{NO}_2$ formed by the test piece ( $\mu\text{mol}$ )
$n_{\text{NO}_x}$	amount of $\text{NO}_x$ removed by the test piece ( $\mu\text{mol}$ )
$n_w$	amount of nitrogen eluted from the test piece ( $\mu\text{mol}$ ); $w_1, w_2$ are the 1st and 2nd elutions, respectively
$V_w$	volume of collected washings (ml); $w_1, w_2$ are the 1st and 2nd elutions, respectively
$\eta_w$	fractional recovery of nitrogen

## 5 Principle

This document concerns the development, comparison, quality assurance, characterization, reliability, and design data generation of photocatalytic materials.<sup>[1]</sup> The method described is intended to obtain the air-purification performance of photocatalytic materials by exposing a test piece to model polluted air under illumination by ultraviolet (UV) light.<sup>[2]</sup> Nitric oxide (NO) is chosen as a typical air pollutant that gives nonvolatile products on the photocatalyst. The test piece, placed in a flow-type photoreactor, is activated by UV illumination, and adsorbs and oxidizes gas-phase NO to form nitric acid (or nitrate) on its surface.<sup>[3]</sup> A part of the NO is converted to nitrogen dioxide ( $\text{NO}_2$ ) on the test piece. The air-purification performance is determined from the amount of the net removal of nitrogen oxides ( $\text{NO}_x$ ) (= NO removed –  $\text{NO}_2$  formed). The simple adsorption and desorption of NO by the test piece (not due to photocatalysis) are evaluated by tests in the dark. Although the photocatalytic activity is reduced by the accumulation of reaction products, it is usually restored by washing with water.<sup>[4]</sup> The elution test provided here gives information about the ease of regeneration and material balance of the pollutants.

## 6 Apparatus

### 6.1 Test equipment

The test equipment enables a photocatalytic material to be examined for its pollutant-removal capability by supplying the test gas continuously, while providing photoirradiation to activate the photocatalyst. It consists of a test gas supply, a photoreactor, a light source, and pollutant measurement equipment. Since low concentrations of pollutants are to be tested, the system shall be constructed with materials of low adsorption and resistant to ultraviolet (UV) radiation, for example, acrylic resin, stainless steel, glass and fluorocarbon polymers. An example of a test system is shown in [Figure 1](#).

### 6.2 Test gas supply

The test gas supply provides air polluted with the model contaminant at a predetermined concentration, temperature and humidity, and supplies it continuously to the photoreactor. It consists of flow regulators, a humidifier, gas mixers, etc. The flow rate of each gas should be within 5 % of the designated value, which is easily attained by using thermal mass-flow controllers, with the knowledge of calibrated gas flow rate and temperature in accordance with ISO 6145-7. Typical capacities of the flow controller

for pollutant gas, dry air and wet air are 0,1 l/min, 2,0 l/min and 2,0 l/min, respectively. The expression of gas flow rate in this document is that converted to the standard state (0 °C, 101,3 kPa). The standard NO gas, normally balanced with nitrogen in a cylinder, shall have a volume fraction of 30 µl/l to 100 µl/l, because the oxidation of NO to NO<sub>2</sub> upon mixing with purified air becomes prominent with a higher concentration of NO.

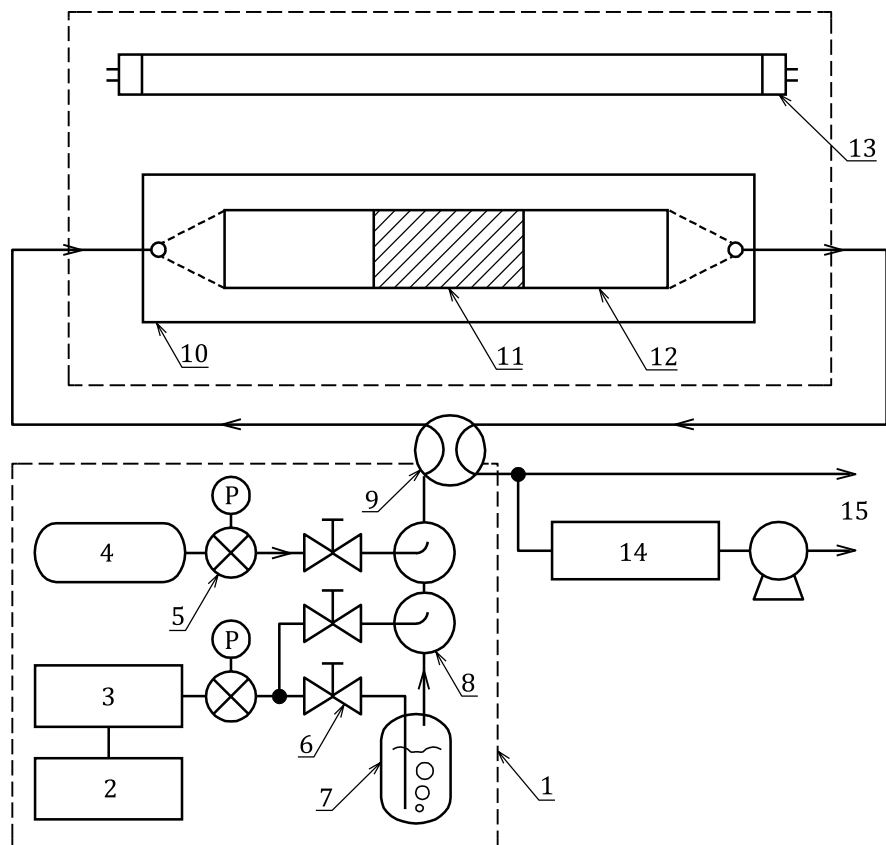

**Key**

- |                            |                        |                             |
|----------------------------|------------------------|-----------------------------|
| 1 test gas supply          | 6 mass-flow controller | 11 test piece               |
| 2 air compressor           | 7 humidifier           | 12 air-tight optical window |
| 3 air-purification system  | 8 gas mixer            | 13 light source             |
| 4 standard gas (pollutant) | 9 4-way valve          | 14 analyser                 |
| 5 pressure regulator       | 10 photoreactor        | 15 vent                     |

**Figure 1 — Schematic of the test equipment**

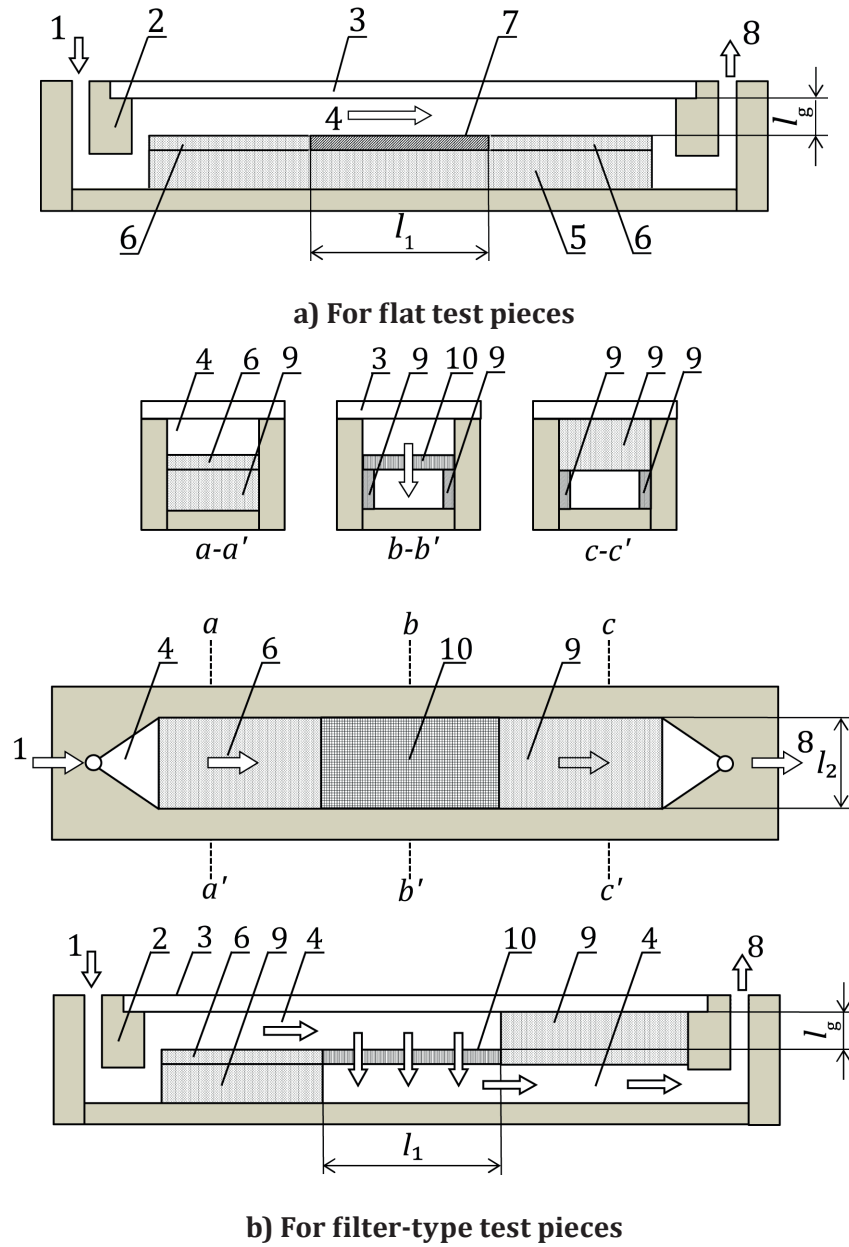

Test piece length $l_1$	Test piece width $l_2$	Air layer thickness $l_g$
99,0 mm ± 1,0 mm	49,0 mm ± 1,0 mm	5,0 mm ± 0,5 mm

**Key**

- |                            |                             |
|----------------------------|-----------------------------|
| 1 test gas inlet           | 6 auxiliary plate           |
| 2 baffle                   | 7 test piece (flat-type)    |
| 3 air-tight optical window | 8 test gas outlet           |
| 4 flow channel             | 9 test piece holder         |
| 5 height-adjusting plate   | 10 test piece (filter-type) |

**Figure 2 — Cross-sectional view of photoreactor**

### 6.3 Photoreactor

The photoreactor holds a planar test piece within a 50 mm wide trough, with its surface parallel to an air-tight optical window for photoirradiation. The reactor shall be fabricated from materials that adsorb minimal test gas and withstand irradiation of near-UV light. The test piece shall be separated from the window by a  $5,0 \text{ mm} \pm 0,5 \text{ mm}$  thick air layer. The test gas shall pass only through the space between the test piece and the window. This gap shall be accurately set up, for example, by using height-adjusting plates with different thicknesses, as shown in [Figure 2 a](#)). When a filter-type photocatalyst is tested, an alternative type of test-piece holder shall be used, which holds the test piece while allowing the test gas to pass through the cells of the filter under illumination [see [Figure 2 b](#))]. Quartz or borosilicate glass that absorbs minimal light at wavelengths longer than 300 nm shall be used for the window.

### 6.4 Light source

The light source shall provide UV-A illumination within a wavelength range of 300 nm to 400 nm. Suitable sources include the so-called black light (BL) and black light blue (BLB) fluorescent lamps, with the maximum at 351 nm, as specified in ISO 4892-3, and xenon lamps with optical filters that block radiation below 300 nm and above 400 nm. The test piece shall be irradiated uniformly through the window by the light source. In the case of testing honeycomb-form photocatalysts, the light source shall illuminate one face of the test piece. A light source that requires warming up shall be equipped with a shutter. The distance between the light source and the reactor shall be adjusted so that the UV irradiance (300 nm to 400 nm) at the sample surface is  $10,0 \text{ W/m}^2 \pm 0,5 \text{ W/m}^2$ . The irradiance along the length of the test piece shall also be constant within  $\pm 5 \%$ . The UV irradiance shall be measured with a radiometer which conforms to ISO 4892-1. The reactor shall be shielded from external light if necessary.

### 6.5 Analyser of pollutants

A chemiluminescent  $\text{NO}_x$  analyser as specified in ISO 7996, or equivalent, shall be used for the accurate determination of  $\text{NO}_x$  concentration. The analyser shall be calibrated using calibration gases having zero  $\text{NO}_x$  and concentrations spanning the range of the test gas before testing. An ion chromatograph as specified in ISO 10304-1, or equivalent, shall be used for the analysis of nitrate and nitrite in water samples.

NOTE The concentration indicated as “ $\text{NO}_2$ ” is calculated by the difference between those of  $\text{NO}_x$  and  $\text{NO}$ , and it can contain  $\text{HNO}_2$ ,  $\text{HNO}_3$  and other nitrogen-containing species, depending on the performance of the catalytic converter used in the analyser.

## 7 Test piece

The test piece shall be  $49,5 \text{ mm} \pm 0,5 \text{ mm}$  wide and  $99,0 \text{ mm} \pm 1,0 \text{ mm}$  long. It may be cut to these dimensions from a larger bulk material or coated sheet, or may be specially prepared for the test by coating a pre-cut substrate. The thickness of the test piece shall ideally be less than 5 mm, in order to minimize the photocatalytic contribution from the side faces. If thicker test pieces are to be tested, the side faces shall be sealed with an inert material before testing. The honeycomb test piece shall not be thicker than 20 mm.

## 8 Procedure

### 8.1 Pretreatment of test piece

**8.1.1** The test piece shall be normally pretreated as [8.1.2](#) and [8.1.3](#) in this order. In case any smear is present, removal of organic matter ([8.1.2](#)) shall be performed before washing with water ([8.1.3](#)).

**8.1.2** Irradiate the test piece with an ultraviolet lamp for at least 16 h to decompose residual organic matter on the test piece. The UV irradiance at the sample surface shall be high enough to secure complete decomposition of organic matter (10 W/m<sup>2</sup> or higher).

**8.1.3** Immerse the test piece in deionized water for 2 h or more, remove it, and air-dry at room temperature. The test piece may be dried by heating within a temperature range that does not cause physical and chemical changes to the test piece (maximum 120 °C). Dryness is confirmed when a constant mass is reached. The method of drying and any observations, such as the appearance of sediment in the wash water, shall be recorded. The pH and the concentrations of nitrate and nitrite ions are measured by the method described in 8.3. If the test pieces are not to be tested immediately after the pretreatment, they shall be kept in an airtight container.

## **8.2 Pollutant-removal test**

**8.2.1** This test uses the following procedure to obtain the amount of the pollutant adsorbed under dark conditions, removed by photoirradiation, and desorbed after photoirradiation. [Figure 3](#) shows a typical volume fraction change of nitric oxide (NO) and nitrogen dioxide (NO<sub>2</sub>) during the test procedure.

**8.2.2** Adjust the test gas supply beforehand so that it can stably supply the test gas containing 1,0 µl/l ± 0,05 µl/l of NO and 1,56 % ± 0,08 % of volume fraction of water vapour at 25,0 °C ± 2,5 °C. This water-vapour volume fraction is equivalent to a relative humidity of 50 % at 25 °C. The relative humidity shall be measured by using a hygrometer (with accuracy of ±3 % RH) that has been calibrated by a method traceable to a certified reference standard. Measure and record the irradiance from the light source. Warm up and calibrate the pollutant analyser during this period.

**8.2.3** Place the test piece in the photoreactor and attach the glass window after adjusting the space between the test piece and the window to 5,0 mm ± 0,5 mm. Check that the reactor is sealed by visual examination of the sealing material, such as an O-ring, for tight contact against the glass window.

**8.2.4** Allow the test gas to flow into the photoreactor, without photoirradiation. The flow rate shall be 3,0 l/min ± 0,15 l/min (equivalent to a velocity of approximately 0,2 m/s for the vessel dimensions described above). Continue the flow for 30 min and record the change in the volume fraction of NO and nitrogen dioxide (NO<sub>2</sub>) under dark conditions. If the NO<sub>x</sub> volume fraction is less than 90 % of the volume fraction supplied after 30 min, continue until it exceeds this.

**8.2.5** Maintain the gas flow and commence irradiation of the sample, and record the NO and NO<sub>2</sub> volume fractions under photoirradiation for 5 h.

**8.2.6** Stop photoirradiation, switch to the zero-calibration gas under the same flow conditions and record the NO<sub>x</sub> volume fraction for 30 min. When it is necessary to check the initial NO concentration (1,0 parts per million), stop photoirradiation and confirm the concentration by switching the 4-way valve to bypass the photoreactor. Then, switch the valve to the previous position and continue the procedure.

8.2.7 Stop the gas supply to the reactor and remove the test piece from the reactor.

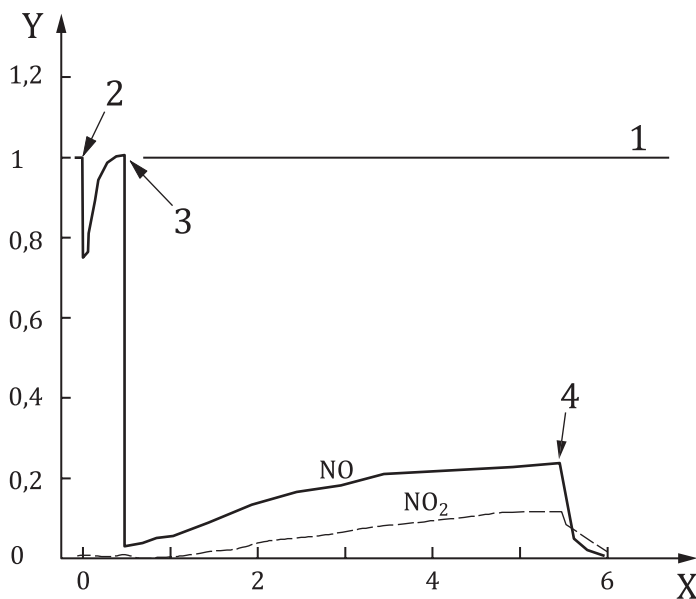

**Key**

- 1 NO feed level
- 2 contact start
- 3 lights on
- 4 lights off, zero-calibration gas
- X time (h)
- Y NO, NO<sub>2</sub> (µl/l)

**Figure 3 — Typical trace of NO<sub>x</sub> concentration during the test operation**

### 8.3 Elution test

8.3.1 Immerse the test piece in a known quantity of purified water (about 50 ml) for 1 h. Remove the test piece and record the volume of the water (hereinafter called Washing 1). Immerse the test piece again in a second known quantity of purified water for 1 h. Remove the test piece and record the volume of the water (Washing 2). Record any observations, such as discoloration of the washings or the presence of sediment.

NOTE 1 When the test piece absorbs water, the quantity of water can be increased appropriately.

NOTE 2 For test pieces presenting difficulties with elution, e.g. due to strong water absorption, a retest after drying the test piece can be performed, omitting the procedure in 8.1.3, to show that the removal performance is constant for the repeated tests.

8.3.2 Measure the pH of Washings 1 and 2 in accordance with ISO 10523, together with the concentrations of nitrate and nitrite determined in accordance with ISO 10304-1.

## 9 Calculation

### 9.1 Calculation method

The test results shall be calculated as follows. The calculated values are usually rounded to one decimal place in accordance with ISO 80000-1. The fractional recovery of nitrogen is rounded to two decimal places.

## 9.2 Amount of NO<sub>x</sub> adsorption by the test piece

The amount of adsorption from the test gas is calculated by the following formula:

$$n_{\text{ads}} = (f / 22,4) \left\{ \int (\phi_{\text{NO}_i} - \phi_{\text{NO}}) dt - \int \phi_{\text{NO}_2} dt \right\} \quad (1)$$

where

$n_{\text{ads}}$  is the amount of NO<sub>x</sub> adsorbed by the test piece (μmol);

$f$  is the air-flow rate converted into that at the standard state (0 °C, 101,3 kPa) (l/min);

$\phi_{\text{NO}_i}$  is the supply volume fraction of nitric oxide (μl/l);

$\phi_{\text{NO}}$  is the nitric oxide volume fraction at the reactor exit (μl/l);

$\phi_{\text{NO}_2}$  is the nitrogen dioxide volume fraction at the reactor exit (μl/l).

The integrations are taken over the time, in minutes, of the adsorption operation, i.e. the time between *contact start* and *lights on* as shown in [Figure 3](#).

## 9.3 Amount of NO removed by the test piece

The amount of NO removed from the test gas is calculated by the following formula:

$$n_{\text{NO}} = (f / 22,4) \int (\phi_{\text{NO}_i} - \phi_{\text{NO}}) dt \quad (2)$$

where

$n_{\text{NO}}$  is the amount of NO removed by the test piece (μmol).

The other symbols are as defined in [9.2](#).

The integration is taken over the time, in minutes, for which the sample is illuminated, i.e. the time between *lights on* and *lights off* as shown in [Figure 3](#).

## 9.4 Amount of NO<sub>2</sub> formed by the test piece

The amount of NO<sub>2</sub> formed is calculated by the following formula:

$$n_{\text{NO}_2} = (f / 22,4) \int \phi_{\text{NO}_2} dt \quad (3)$$

where

$n_{\text{NO}_2}$  is the amount of NO<sub>2</sub> formed by the test piece (μmol).

The other symbols are as defined in [9.2](#).

The integration is taken over the time, in minutes, for which the sample is illuminated, i.e. the time between *lights on* and *lights off* as shown in [Figure 3](#).

### 9.5 Amount of NO<sub>x</sub> desorbed from the test piece

The amount of NO<sub>x</sub> desorbed is calculated by the following formula:

$$n_{\text{des}} = (f / 22, 4) \left\{ \int \phi_{\text{NO}} dt + \int \phi_{\text{NO}_2} dt \right\} \quad (4)$$

where

$n_{\text{des}}$  is the amount of NO<sub>x</sub> desorbed from the test piece (μmol).

The other symbols are as defined in [9.2](#).

The integration is taken over the time, in minutes, between *lights off* and the end of the test as shown in [Figure 3](#).

### 9.6 Net amount of NO<sub>x</sub> removed by the test piece

The net amount of NO<sub>x</sub> removed is calculated by the following formula:

$$n_{\text{NO}_x} = n_{\text{ads}} + n_{\text{NO}} - n_{\text{NO}_2} - n_{\text{des}} \quad (5)$$

where

$n_{\text{NO}_x}$  is the amount of NO<sub>x</sub> removed by the test piece (μmol).

The other symbols are as defined in [9.2](#) to [9.5](#).

When  $n_{\text{NO}_x}$  is below 1,0 μmol,  $n_{\text{NO}_x}$  is expressed as “below 1,0 μmol”.

### 9.7 Nitrogen eluted from the test piece

The amount of nitrogen eluted is calculated by the following formula:

$$n = n_{w1} + n_{w2} = V_{w1} \left( \rho_{\text{NO}_3^-, w1} / 62 + \rho_{\text{NO}_2^-, w1} / 46 \right) + V_{w2} \left( \rho_{\text{NO}_3^-, w2} / 62 + \rho_{\text{NO}_2^-, w2} / 46 \right) \quad (6)$$

where

$n$  is the amount of nitrogen eluted from the test piece (μmol);

$V$  is the volume of collected washings (ml);

$\rho_{\text{NO}_3^-}$  is the nitrate ion concentration in the eluent from the test piece (mg/l);

$\rho_{\text{NO}_2^-}$  is the nitrite ion concentration in the eluent from the test piece (mg/l);

$w_1, w_2$  are the 1st and 2nd elutions, respectively.



## 9.8 Recovery of washing with water

The fractional recovery of nitrogen is calculated to two decimal places by the following formula:

$$\eta_w = (n_{w1} + n_{w2}) / n_{NO_x} \quad (7)$$

where

$\eta_w$  is the fractional recovery of nitrogen;

the other symbols are as defined in 9.6 and 9.7.

## 10 Test method for test pieces with lower performance

In case the amount of the removal quantity is less than 2,0  $\mu\text{mol}$  (about 5 % in removal percentage), the number of test pieces and the flow rate of test gas may be altered at the same time as shown in [Table 1](#). However, the amounts of  $\text{NO}_x$  removal,  $\text{NO}_2$  formed, and  $\text{NO}_x$  adsorbed/desorbed to appear in the test report shall be half of the values calculated from [Formulae \(1\) to \(5\)](#), as well as using the flow rate of 1,5 l/min. If the  $\text{NO}_x$  removal is less than 0,25  $\mu\text{mol}$ , report as “less than 0,25  $\mu\text{mol}$ ”.

**Table 1 — Alternative test conditions**

Alternative test conditions	Value after change
Test gas flow rate	1,500 l/min $\pm$ 0,075 l/min
Number of test pieces	2 pieces

## 11 Test report

The test report shall be in accordance with the reporting provisions of ISO/IEC 17025 and shall include the following information. Items g) and h) shall be reported for each test.

- a) the name and address of the testing establishment;
- b) the date of the test, a unique identification of the report and of each page, the customer name and address, and the signatory of the report;
- c) a reference to this document, i.e. determined in accordance with ISO 22197-1:2016;
- d) date of test, temperature, relative humidity, etc;
- e) description of the test piece (material, size, shape, etc.);
- f) description of testing equipment (specifications, etc.);
- g) testing conditions (kind of pollutant gas, supply concentration, water-vapour concentration, flow rate, kind of light source, irradiance, analyser and radiometer used, conditions of pretreatment, and modification under [Clause 10](#), etc.);
- h) the amounts of  $\text{NO}_x$  removed,  $\text{NO}_2$  generated,  $\text{NO}_x$  adsorbed, and  $\text{NO}_x$  desorbed by the test piece, and fractional recovery by washing with water (optional);
- i) any other matters of special importance, such as a change in the test piece noticed during the test.

## Annex A (informative)

### Results of round-robin test

A round-robin test was undertaken between four collaborating laboratories. Each prepared the testing equipment including the photoreactor separately. The organizing laboratory visited each party during the test with a standard gas cylinder (about 50 µl/l NO/nitrogen), calibrated gas flowmeter and UV-A radiometer to check and calibrate its equipment. Each laboratory made four tests using the paper-based photocatalyst supplied. The original data are shown in [Table A.1](#).

**Table A.1 — Results of round-robin test**

Unit: µmol

Laboratory (run no.)	NO removed	NO <sub>x</sub> removed	NO <sub>2</sub> formed	Laboratory (run no.)	NO removed	NO <sub>x</sub> removed	NO <sub>2</sub> formed
A (1)	24,3	15,2	8,9	C (1)	24,3	13,8	10,5
A (2)	24,1	14,6	9,1	C (2)	24,2	14,5	9,6
A (3)	24,1	14,9	8,8	C (3)	24,2	14,7	9,4
A (4)	24,8	15,4	8,9	C (4)	24,3	14,5	9,7
B (1)	24,8	14,6	10,2	D (1)	25,2	15,5	9,7
B (2)	24,8	15,5	9,4	D (2)	24,7	15,3	9,4
B (3)	24,8	15,4	9,4	D (3)	24,2	15,0	9,2
B (4)	25,1	15,7	9,3	D (4)	24,7	15,2	9,5

The overall mean, repeatability standard deviation and reproducibility standard deviation, as computed in accordance with ISO 5725-2, are summarized in [Table A.2](#).

**Table A.2 — Statistical data obtained in accordance with ISO 5725-2**

Unit: µmol

	Overall mean	Repeatability standard deviation	Reproducibility standard deviation
NO removed	24,54	0,28	0,38
NO <sub>x</sub> removed	14,99	0,37	0,53
NO <sub>2</sub> formed	9,44	0,33	0,46

For the light source, some laboratories used a BL fluorescent lamp, while others used a BLB fluorescent lamp. However, no significant difference was observed as long as the UV-A irradiance was set at the specified value. In further tests, the NO<sub>x</sub> removal results obtained with different photocatalyst samples, such as tile, cement-coated plate, painted aluminium plate, etc., varied from <1,0 µmol to 20,0 µmol, which indicated that this method can differentiate the samples with different photocatalytic performance.

## Bibliography

- [1] FUJISHIMA A., HASHIMOTO K., WATANABE T. *TiO<sub>2</sub> photocatalysis. Fundamentals and applications*. BKC Inc, Tokyo, 1999
- [2] JAPANESE INDUSTRIAL STANDARD COMMITTEE. *Photocatalytic materials – Air purification test procedure, TR Z 0018*. Japanese Standard Association, 2002
- [3] IBUSUKI T., & TAKEUCHI K. Removal of low concentration nitrogen oxides through photoassisted heterogeneous catalysis. *J. Mol. Catal.* 1994, **88** pp. 93–102
- [4] TAKEUCHI K. Purification and remediation of ambient air by photocatalysis [in Japanese]. *J. Jpn. Soc. Atmos. Environ.* 1998, **33** (3) pp. 139–150





# British Standards Institution (BSI)

BSI is the national body responsible for preparing British Standards and other standards-related publications, information and services.

BSI is incorporated by Royal Charter. British Standards and other standardization products are published by BSI Standards Limited.

## About us

We bring together business, industry, government, consumers, innovators and others to shape their combined experience and expertise into standards-based solutions.

The knowledge embodied in our standards has been carefully assembled in a dependable format and refined through our open consultation process. Organizations of all sizes and across all sectors choose standards to help them achieve their goals.

## Information on standards

We can provide you with the knowledge that your organization needs to succeed. Find out more about British Standards by visiting our website at [bsigroup.com/standards](http://bsigroup.com/standards) or contacting our Customer Services team or Knowledge Centre.

## Buying standards

You can buy and download PDF versions of BSI publications, including British and adopted European and international standards, through our website at [bsigroup.com/shop](http://bsigroup.com/shop), where hard copies can also be purchased.

If you need international and foreign standards from other Standards Development Organizations, hard copies can be ordered from our Customer Services team.

## Copyright in BSI publications

All the content in BSI publications, including British Standards, is the property of and copyrighted by BSI or some person or entity that owns copyright in the information used (such as the international standardization bodies) and has formally licensed such information to BSI for commercial publication and use.

Save for the provisions below, you may not transfer, share or disseminate any portion of the standard to any other person. You may not adapt, distribute, commercially exploit, or publicly display the standard or any portion thereof in any manner whatsoever without BSI's prior written consent.

## Storing and using standards

Standards purchased in soft copy format:

- A British Standard purchased in soft copy format is licensed to a sole named user for personal or internal company use only.
- The standard may be stored on more than 1 device provided that it is accessible by the sole named user only and that only 1 copy is accessed at any one time.
- A single paper copy may be printed for personal or internal company use only.

Standards purchased in hard copy format:

- A British Standard purchased in hard copy format is for personal or internal company use only.
- It may not be further reproduced – in any format – to create an additional copy. This includes scanning of the document.

If you need more than 1 copy of the document, or if you wish to share the document on an internal network, you can save money by choosing a subscription product (see 'Subscriptions').

## Reproducing extracts

For permission to reproduce content from BSI publications contact the BSI Copyright & Licensing team.

## Subscriptions

Our range of subscription services are designed to make using standards easier for you. For further information on our subscription products go to [bsigroup.com/subscriptions](http://bsigroup.com/subscriptions).

With **British Standards Online (BSOL)** you'll have instant access to over 55,000 British and adopted European and international standards from your desktop. It's available 24/7 and is refreshed daily so you'll always be up to date.

You can keep in touch with standards developments and receive substantial discounts on the purchase price of standards, both in single copy and subscription format, by becoming a **BSI Subscribing Member**.

**PLUS** is an updating service exclusive to BSI Subscribing Members. You will automatically receive the latest hard copy of your standards when they're revised or replaced.

To find out more about becoming a BSI Subscribing Member and the benefits of membership, please visit [bsigroup.com/shop](http://bsigroup.com/shop).

With a **Multi-User Network Licence (MUNL)** you are able to host standards publications on your intranet. Licences can cover as few or as many users as you wish. With updates supplied as soon as they're available, you can be sure your documentation is current. For further information, email [subscriptions@bsigroup.com](mailto:subscriptions@bsigroup.com).

## Revisions

Our British Standards and other publications are updated by amendment or revision.

We continually improve the quality of our products and services to benefit your business. If you find an inaccuracy or ambiguity within a British Standard or other BSI publication please inform the Knowledge Centre.

## Useful Contacts

### Customer Services

**Tel:** +44 345 086 9001

**Email (orders):** [orders@bsigroup.com](mailto:orders@bsigroup.com)

**Email (enquiries):** [cservices@bsigroup.com](mailto:cservices@bsigroup.com)

### Subscriptions

**Tel:** +44 345 086 9001

**Email:** [subscriptions@bsigroup.com](mailto:subscriptions@bsigroup.com)

### Knowledge Centre

**Tel:** +44 20 8996 7004

**Email:** [knowledgecentre@bsigroup.com](mailto:knowledgecentre@bsigroup.com)

### Copyright & Licensing

**Tel:** +44 20 8996 7070

**Email:** [copyright@bsigroup.com](mailto:copyright@bsigroup.com)

### BSI Group Headquarters

389 Chiswick High Road London W4 4AL UK