

Intelligent transport systems — Low speed following (LSF) systems — Performance requirements and test procedures

ICS 43.040.15

National foreword

This British Standard is the UK implementation of ISO 22178:2009.

The UK participation in its preparation was entrusted to Technical Committee EPL/278, Road transport informatics.

A list of organizations represented on this committee can be obtained on request to its secretary.

This publication does not purport to include all the necessary provisions of a contract. Users are responsible for its correct application.

Compliance with a British Standard cannot confer immunity from legal obligations.

This British Standard was published under the authority of the Standards Policy and Strategy Committee on 31 August 2009

© BSI 2009

ISBN 978 0 580 58135 9

Amendments/corrigenda issued since publication

Date	Comments

INTERNATIONAL STANDARD

ISO
22178

First edition
2009-04-01

Intelligent transport systems — Low speed following (LSF) systems — Performance requirements and test procedures

*Systèmes intelligents de transport — Systèmes suiveurs à basse
vitesse (LSF) — Exigences de performance et méthodes d'essai*



Reference number
ISO 22178:2009(E)

© ISO 2009

PDF disclaimer

This PDF file may contain embedded typefaces. In accordance with Adobe's licensing policy, this file may be printed or viewed but shall not be edited unless the typefaces which are embedded are licensed to and installed on the computer performing the editing. In downloading this file, parties accept therein the responsibility of not infringing Adobe's licensing policy. The ISO Central Secretariat accepts no liability in this area.

Adobe is a trademark of Adobe Systems Incorporated.

Details of the software products used to create this PDF file can be found in the General Info relative to the file; the PDF-creation parameters were optimized for printing. Every care has been taken to ensure that the file is suitable for use by ISO member bodies. In the unlikely event that a problem relating to it is found, please inform the Central Secretariat at the address given below.



COPYRIGHT PROTECTED DOCUMENT

© ISO 2009

All rights reserved. Unless otherwise specified, no part of this publication may be reproduced or utilized in any form or by any means, electronic or mechanical, including photocopying and microfilm, without permission in writing from either ISO at the address below or ISO's member body in the country of the requester.

ISO copyright office
Case postale 56 • CH-1211 Geneva 20
Tel. + 41 22 749 01 11
Fax + 41 22 749 09 47
E-mail copyright@iso.org
Web www.iso.org

Published in Switzerland

Contents

Page

Foreword.....	iv
Introduction	v
1 Scope	1
2 Normative references	1
3 Terms and definitions	1
4 Symbols and abbreviated terms	3
5 Classification — types of LSF systems	4
6 Requirements	4
6.1 Basic control strategy	4
6.2 Applicable target vehicle	6
6.3 Functionality.....	8
6.4 Basic driver interface and intervention capabilities	10
6.5 Operational limits.....	11
6.6 Activation of brake lights.....	12
6.7 Failure reactions	12
6.8 Combination with other systems	13
7 Performance evaluation test methods.....	13
7.1 Environmental conditions.....	13
7.2 Test target specification	14
7.3 Detection zone test	14
7.4 Target discrimination test.....	15
7.5 Automatic deceleration test.....	17
7.6 Automatic retargeting capability test (type 2 LSF system only).....	18
7.7 Curve capability test.....	19
Annex A (normative) Technical information.....	23
Bibliography	28

Foreword

ISO (the International Organization for Standardization) is a worldwide federation of national standards bodies (ISO member bodies). The work of preparing International Standards is normally carried out through ISO technical committees. Each member body interested in a subject for which a technical committee has been established has the right to be represented on that committee. International organizations, governmental and non-governmental, in liaison with ISO, also take part in the work. ISO collaborates closely with the International Electrotechnical Commission (IEC) on all matters of electrotechnical standardization.

International Standards are drafted in accordance with the rules given in the ISO/IEC Directives, Part 2.

The main task of technical committees is to prepare International Standards. Draft International Standards adopted by the technical committees are circulated to the member bodies for voting. Publication as an International Standard requires approval by at least 75 % of the member bodies casting a vote.

Attention is drawn to the possibility that some of the elements of this document may be the subject of patent rights. ISO shall not be held responsible for identifying any or all such patent rights.

ISO 22178 was prepared by Technical Committee ISO/TC 204, *Intelligent transport systems*.

Introduction

The main system function of low speed following is to control vehicle speed adaptively to a forward vehicle by using information about: (1) ranging to forward vehicles, (2) the motion of the subject (LSF equipped) vehicle and (3) driver commands (see Figure 1 — Functional LSF elements). Based upon the information acquired, the controller (identified as “LSF control strategy” in Figure 1) sends commands to actuators for carrying out its longitudinal control strategy and also sends status information to the driver.

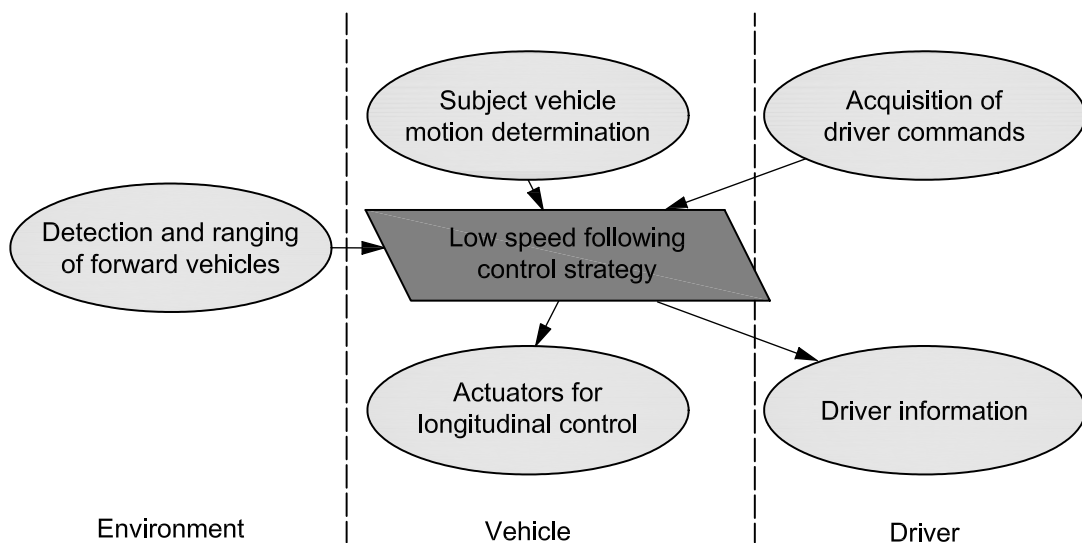

Figure 1 — Functional LSF elements

The goal of LSF is a partial automation of the longitudinal vehicle control to reduce the driver’s workload.

This International Standard may be used as a system level standard by other standards, which extend the LSF to a more detailed standard, e.g. for specific detection and ranging sensor concepts or higher level of functionality. Therefore, issues like specific requirements for the detection and ranging sensor function and performance or communication links for co-operative solutions will not be considered here.

Intelligent transport systems — Low speed following (LSF) systems — Performance requirements and test procedures

1 Scope

This International Standard contains the basic control strategy, minimum functionality requirements, basic driver-interface elements, minimum requirements for diagnostics and reaction to failure, and performance test procedures for low speed following (LSF) systems.

An LSF system is primarily intended to reduce the driver's workload of repeatedly operating the accelerator and the brake pedal under congested traffic in order to keep a proper following distance behind the target vehicle for a relatively long period on roadways where there are no objects like pedestrians and bicyclists who might interrupt motorized traffic flow. An LSF system provides automatic car-following at lower speed by use of a driver interface mechanism and a speed adjustment system. The LSF system does not normally provide speed regulator control.

2 Normative references

The following referenced documents are indispensable for the application of this document. For dated references, only the edition cited applies. For undated references, the latest edition of the referenced document (including any amendments) applies.

ISO 2575, *Road vehicles — Symbols for controls, indicators and tell-tales*

3 Terms and definitions ¹⁾

For the purposes of this document, the following terms and definitions apply.

3.1

clearance

distance from the forward vehicle's trailing surface to the subject vehicle's leading surface

3.2

congested traffic

traffic condition where the driver, at lower speed, repeatedly starts, follows a forward vehicle, and stops in order to keep a proper following distance behind the forward vehicle

3.3

cutting out

situation in which the target vehicle changes lanes from behind a preceding vehicle

1) Definitions are in accordance with the Glossary of ISO/TC 204/WG 14.

- 3.4 forward vehicle**
vehicle in front of, and moving in the same direction and travelling on the same roadway as, the subject vehicle
- 3.5 go operation**
driver action to convey to the system the intention of placing the subject vehicle in motion
- EXAMPLE Operation of the accelerator pedal and operation of a switch for starting the subject vehicle.
- 3.6 low speed following LSF**
function that allows the subject vehicle to follow a forward vehicle in low speed ranges such as congested traffic at an appropriate distance by controlling the engine and/or power train and the brakes
- 3.7 LSF following state**
condition where the system controls the clearance to the target vehicle according to the selected time gap
- 3.8 LSF hold state**
condition where the system controls the subject vehicle to be kept stationary
- 3.9 LSF retargeting state**
temporary target-lost period during a transition to the next target vehicle
- 3.10 maximum operational speed**
maximum speed the LSF system can attain while in following control
- 3.11 minimum operational speed**
minimum speed the LSF system can maintain while in following control
- 3.12 slow moving object**
object in front of the subject vehicle that is moving at less than MAX [1,0 m/s, 10 % of the subject vehicle speed] in the direction of the centreline of the subject vehicle
- 3.13 stationary object**
object in front of the subject vehicle that is stationary
- 3.14 steady state**
condition whereby the value of the described parameter does not change with respect to time, distance, etc.
- 3.15 subject vehicle**
vehicle equipped with the LSF system in question and related to the topic of discussion
- 3.16 target vehicle**
vehicle that the subject vehicle follows

3.17

time gap

value calculated from vehicle speed, v , divided by clearance, c

NOTE See Figure 2.

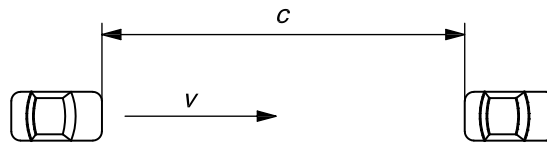

Figure 2 — Time gap

4 Symbols and abbreviated terms

CTT	Coefficient for Test Target (for infrared reflectors) (m^2/sr)
c	clearance, inter vehicle distance (m)
c_{\min}	minimum clearance under steady state conditions for all speeds (including hold state) (m)
$c_{\min}(v)$	minimum steady state clearance at speed v (m)
d_{\max}	distance, maximum detection range on straight roads (m)
d_A	distance between source and projected area A (m)
$d_{\text{target_limit}}$	distance above which the system shall not regard a target vehicle (m)
d_0	distance below which detection of a target vehicle is not required (m)
d_1	distance below which neither distance measurement nor determination of relative speed is required (m)
l	length (of a side of a RADAR test reflector) (m)
R	curve radius (m)
R_{\min}	minimum curve radius (m)
RCS	RADAR Cross Section (m^2)
v	true subject vehicle speed over ground (m/s)
$v_{\text{circle_start}}$	vehicle speed as it enters a curve of radius R (m/s)
v_{\max}	maximum operational speed (m/s)
v_{\min}	minimum operational speed (m/s)
$v_{\text{vehicle_end}}$	vehicle speed at the end of a test (m/s)
$v_{\text{vehicle_start}}$	vehicle speed at the start of a test (m/s)

A	projected (utilized) area (m ²)
A_t	illuminated surface (m ²)
E_t	intensity of irradiation (W/m ²)
I	radiated intensity (W/sr)
I_{ref}	radiated intensity in a given direction (W/sr)
λ	wavelength (m)
τ	gap, time gap between vehicles (s)
τ_{max}	maximum selectable time gap (s)
$\tau_{\text{max}(v)}$	maximum possible steady state time gap at a given speed v (s)
τ_{min}	minimum selectable time gap (s)
$\tau_{\text{min}(v)}$	minimum steady state time gap at speed v (s)
Φ	radiation source (W)
Φ_{ref}	radiated power (W)
Φ_t	incident radiated power (W)
Ω	solid angle (sr)
Ω_0	solid angle of the source (sr)

5 Classification — types of LSF systems

Two types of LSF systems are addressed in this International Standard.

The type 1 LSF system follows the target vehicle that is recognized when the driver activates the system.

The type 2 LSF system follows the target vehicle that is recognized when the driver activates the system and it retargets the target vehicle automatically until the system is deactivated.

6 Requirements

6.1 Basic control strategy

LSF systems shall, as a minimum, provide the following control strategy and state transitions (see Figure 3).

The following constitutes the fundamental behaviour of LSF systems.

- In the LSF following state, the vehicle speed will be controlled automatically to maintain a clearance to a target vehicle (for car-following capability, see 6.3.2).
- (Type 2 LSF system) In the LSF following state, a new target vehicle will be chosen automatically (for automatic retargeting capability, see 6.3.3).

- (Type 2 LSF system) In the LSF retargeting state, the subject vehicle shall not accelerate (for automatic retargeting capability, see 6.3.3).
- After the subject vehicle has come to a stop, the system shall transfer to the LSF hold or stand-by state (for deactivation conditions, see 6.3.5).
- In the LSF hold state, automatic brake control will be accomplished for keeping the subject vehicle stationary (for hold capability, see 6.3.4).

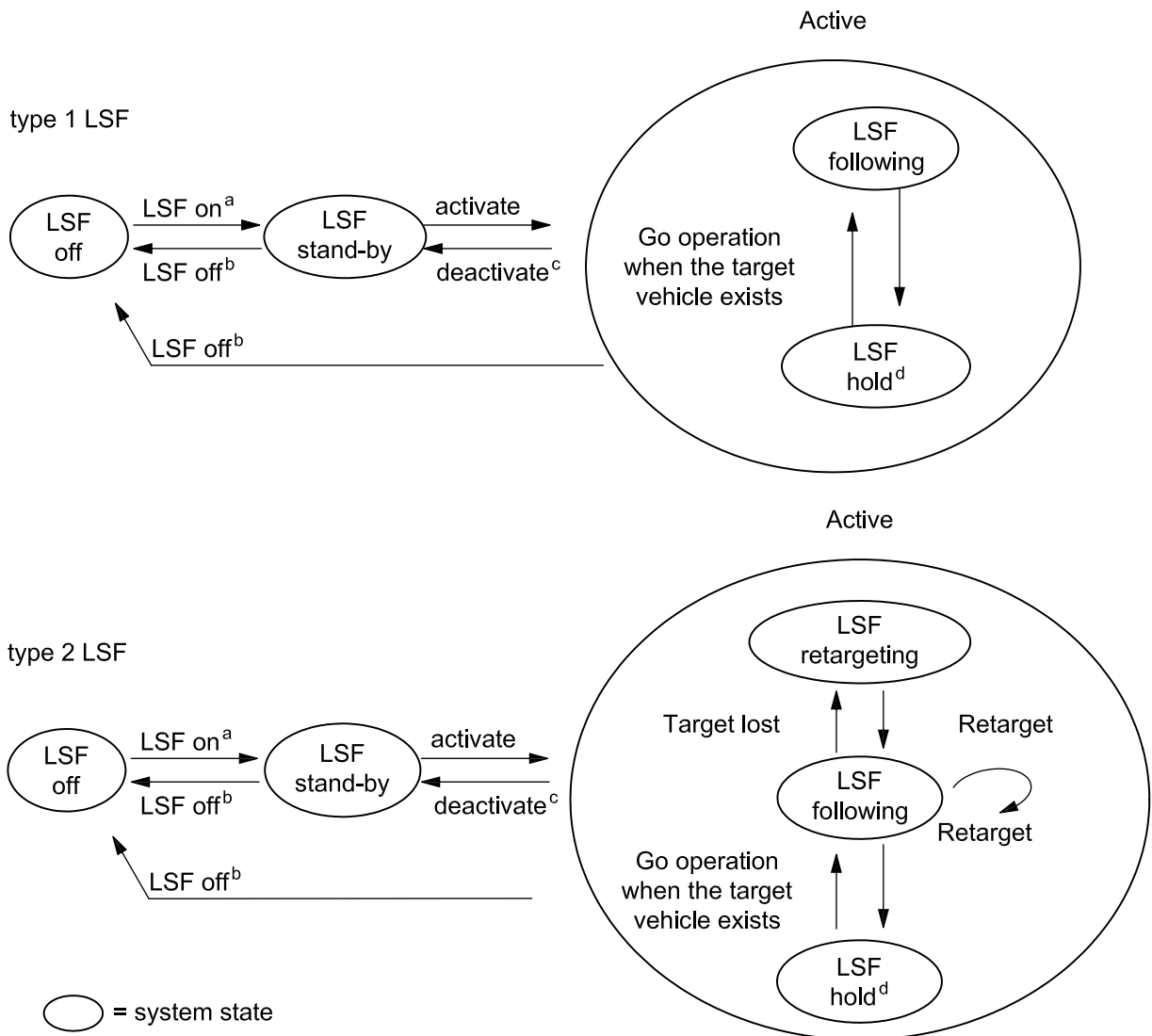

- ^a The transition is driven after self-diagnostics by manual operation or automatically performed.
- ^b The transition is driven by a manual operation of the on-off switch of the LSF system. Automatic switch-off function can be activated upon detecting any failure.
- ^c The driver's operation to deactivate the system or the conditions specified in 6.3.5.
- ^d Optional state.

Figure 3 — LSF states and transitions

6.2 Applicable target vehicle

6.2.1 General

The LSF system shall regard the forward vehicles that conform to the following conditions from 6.2.2 to 6.2.4 as a target vehicle.

6.2.2 Detection targets

The LSF system shall detect moving vehicles.

The LSF system shall regard a stopped vehicle that was tracked before it stopped as a target vehicle.

It is optional to design LSF systems to regard an object that is already stationary or slow-moving when detected as a target vehicle. When stationary objects or slow-moving objects are not regarded as a target vehicle, the driver shall be informed, as a minimum, by a statement in the vehicle owner's manual.

6.2.3 Detection range on straight roads

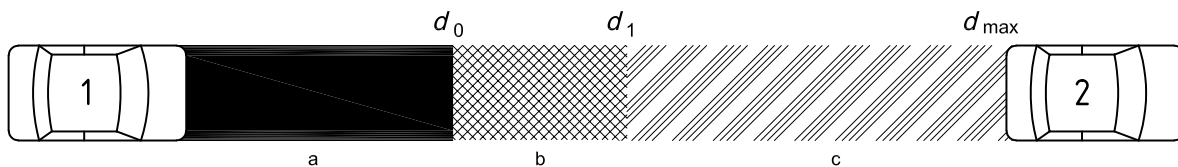

Key

- 1 subject vehicle
- 2 forward vehicle
- a Detection of vehicle not required.
- b Detection of vehicle required.
- c Detection of vehicle and determination of range.

Figure 4 — Range of detection

If a forward vehicle is present within the distance range of d_1 to d_{\max} , the LSF system shall measure the range between the forward and subject vehicles (see Figure 4). Within this range, the forward vehicle shall be detected within a lateral area of at least the subject vehicle width.

$$d_{\max} = \tau_{\max}(v_{\max}) \times v_{\max}$$

If a forward vehicle is present within the distance range of d_0 to d_1 , the LSF system shall detect the presence of the vehicle but is not required to measure the range to the vehicle nor the relative speed between the forward and subject vehicles. If a forward vehicle is detected within this range and the distance cannot be determined, the system shall inhibit automatic acceleration.

$$d_1 = c_{\min}(v_{\min})$$

If a forward vehicle is present at a distance less than d_0 , the LSF system is not required to detect the presence of the vehicle.

$$d_0 = 2 \text{ m}$$

6.2.4 Target discrimination

If there is more than one forward vehicle on straight roads, the closest of these vehicles (see Figure 5) in the subject vehicle's path shall be selected for LSF control in typical LSF situations as represented by the test scenario (for the target discrimination test, see 7.4).

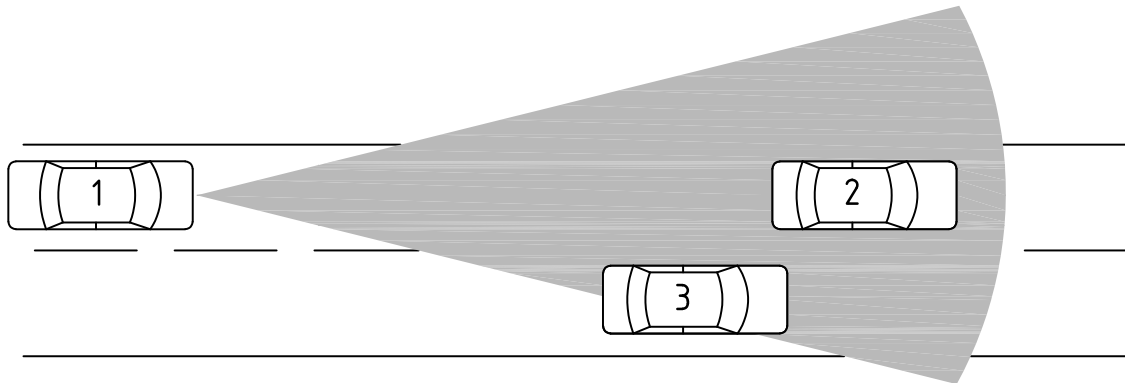

Key

- 1 subject vehicle
- 2 forward vehicle in the subject vehicle's path
- 3 forward vehicle in the adjacent lane

Figure 5 — Target discrimination

If a forward vehicle is in the distance farther than $d_{\text{target_limit}}$, the LSF system shall not regard it as a target vehicle (see Figure 6).

$$d_{\text{target_limit}} = \text{MAX} \left\{ \left[\tau_{\text{max}}(v) \times v \times 3 \right], 36 \right\}$$

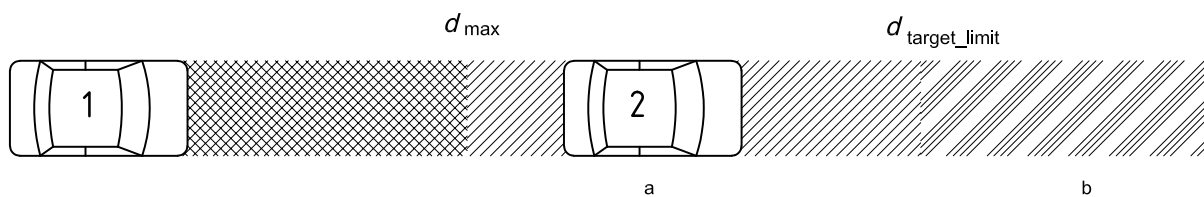

Key

- 1 subject vehicle
- 2 forward vehicle
- a LSF system may regard it as a target vehicle.
- b LSF system shall not regard it as a target vehicle.

Figure 6 — Range of target vehicle

6.3 Functionality

6.3.1 Activation conditions

The following conditions must be satisfied in order to transition to the active state.

- The system shall be activated by a driver.
- The speed of the subject vehicle shall not exceed the system's maximum operation speed.
- The subject vehicle shall already detect the target vehicle.
- The deactivation conditions are not fulfilled.
- The system does not detect any failure.

When the subject vehicle is stopped, it is permissible for the LSF system with hold capability to transition to the LSF hold state even while the driver is operating the brake pedal.

6.3.2 Car-following capability

In the LSF following state, the speed of the subject vehicle shall be controlled automatically in the range of v_{\min} to v_{\max} to maintain the intended clearance from the target vehicle.

The LSF system shall decelerate, within its limited deceleration capability, to v_{\min} behind a stopping target vehicle that is already tracked.

Under the steady state condition, the LSF system shall comply with the minimum clearance limit as defined in 6.3.2.1.

Under transient conditions, the clearance may temporarily fall below the desired distance. If such a situation occurs, the system shall adjust the clearance to attain the desired distance.

6.3.2.1 Clearance capability

τ_{\min} shall be the minimum selectable time gap for following under steady state conditions for all speeds v . $\tau_{\min}(v)$ shall be greater than or equal to $\tau_{\min} = 1,0$ s.

c_{\min} shall be the minimum clearance for following under steady state conditions for all speeds v . $c_{\min}(v)$ shall be greater than or equal to $c_{\min} = 2,0$ m.

Under steady state conditions, the clearance shall not be below $\text{MAX} [c_{\min}, (\tau_{\min} \times v)]$.

6.3.2.2 Curve capability

The LSF system shall enable steady state vehicle following with a time gap of τ_{\max} on a curve with a radius of R greater than or equal to $R_{\min} = 125$ m.

6.3.3 Automatic retargeting capability (type 2 LSF system only)

The type 2 LSF system shall have an automatic retargeting capability to detect a next target vehicle and switch the target at least in the following instances:

- cutting in by other vehicles;
- cutting out by target vehicle.

In the LSF retargeting state, the vehicle speed may be controlled.

In the LSF retargeting state, acceleration shall not be allowed.

The LSF retargeting state shall transfer to the LSF following state at the instant of switching to the new target vehicle.

6.3.4 Hold capability (optional)

The LSF system with $v_{\min} = 0$ may have hold capability as an option.

The LSF system with hold capability shall automatically transfer to the LSF hold state when the subject vehicle comes to stop.

The transition from hold state to following state is enabled by the driver's go operation and can only be effected if the subject vehicle has already detected the target vehicle.

6.3.5 Deactivation conditions

The system shall transfer from the active state to the stand-by state when any of the following conditions occur.

- In the LSF following and the LSF retargeting states, braking by the driver shall deactivate LSF system at least if the driver-initiated brake force demand is higher than the LSF-initiated brake force.
- In the LSF following and the LSF retargeting states, the system shall be deactivated when the subject vehicle speed exceeds v_{\max} .
- In the LSF following and the LSF retargeting states, the system without hold capability shall be deactivated when the subject vehicle speed drops below v_{\min} . In the case of $v_{\min} = 0$, the system shall be deactivated within 3 s after the subject vehicle has come to a stop.
- In the LSF following state, the type 1 LSF system shall be deactivated when cutting in/out occurs or when no target vehicle is present.
- If the target vehicle comes closer than d_0 and is no longer detected, the type 1 and type 2 LSF systems shall inhibit automatic acceleration and may continue braking.
- In the LSF retargeting state, the type 2 LSF system shall be deactivated either when the duration of this state exceeds τ_{\max} or when the subject vehicle reaches the location where the target vehicle was when it was lost.

NOTE τ_{\max} is the maximum selectable time gap, i.e. it is the clearance divided by the subject vehicle speed (> 0) normally used and at which a driver expects retargeting.

- In the LSF hold state, braking by the driver may not necessarily deactivate the LSF system.
- In the LSF hold state, when the system deactivates automatically, the deactivate condition shall be clearly stated in the owner's manual of the vehicle and a notification shall be provided when deactivation occurs.

6.4 Basic driver interface and intervention capabilities

6.4.1 General

The system shall provide the following controls and intervention capabilities.

6.4.2 Operation elements and system reactions

6.4.2.1 The LSF system shall not lead to a significant transient reduction of braking in response to the driver's braking input even when the LSF system has been braking automatically.

6.4.2.2 The larger of the power demands from either the driver or the LSF system will be used to drive the engine power actuator (e.g. throttle actuator). This always gives the driver authority to override the LSF system engine power control.

If the power demand of the driver is greater than that of the LSF system, automatic braking shall be disengaged with an immediate brake force release. A driver intervention on the accelerator pedal shall not lead to a significant delay of response to driver's input.

6.4.2.3 Automatic brake activation shall not lead to locked wheels for periods longer than anti lock devices (ABS) would allow. This need not require an anti lock device (ABS) system.

6.4.2.4 Automatic power control by LSF shall not lead to excessive positive wheel slip for periods longer than traction control would allow. This need not require a traction control system.

6.4.2.5 The LSF system may automatically adjust the clearance without action by the driver in order to respond to the driving environment (e.g. poor weather). However, the adjusted clearance shall not be less than the minimum clearance selected by the driver.

6.4.2.6 If the system allows the driver to select a desired clearance and/or time gap, the selection method shall conform to either one of the following.

- a) If the system retains the last selected clearance and/or time gap after it is switched to LSF off, the clearance and/or time gap shall be clearly presented to the driver at least upon system activation.
- b) If the system does not retain the last selected clearance and/or time gap after it is switched to LSF off, the clearance and/or time gap shall be set to a predefined default value.

6.4.3 Display elements

6.4.3.1 In the stand-by state, an active-ready signal meaning that the LSF system is ready to transition from stand-by state to active state, which will be used for the adaptation of the control, is recommended.

6.4.3.2 In the active state, the type 2 LSF system shall have visual display indicating when a target vehicle is detected.

6.4.3.3 The system shall have visual display indicating when the system is in the active state.

6.4.3.4 If the LSF system shuts down or is not available due to a failure, the driver shall be informed.

6.4.4 Symbols

If symbols are used to identify LSF function or malfunction, standardized symbols in accordance with ISO 2575 shall be used.

6.5 Operational limits

v_{\max} shall not exceed 13,9 m/s.

v_{\min} shall not exceed 1,39 m/s ($0 \leq v_{\min} \leq 1,39$ m/s).

There shall not be a sudden brake force release in the case of an automatic deactivation of the LSF system.

The average automatic deceleration of LSF systems shall not exceed 3,5 m/s² (average over 2 s) when the vehicle is travelling above 20 m/s and 5 m/s² (average over 2 s) when the vehicle is travelling below 5 m/s, as shown in Figure 7. The vehicle speed range 0 m/s to 13,9 m/s only applies to the LSF systems.

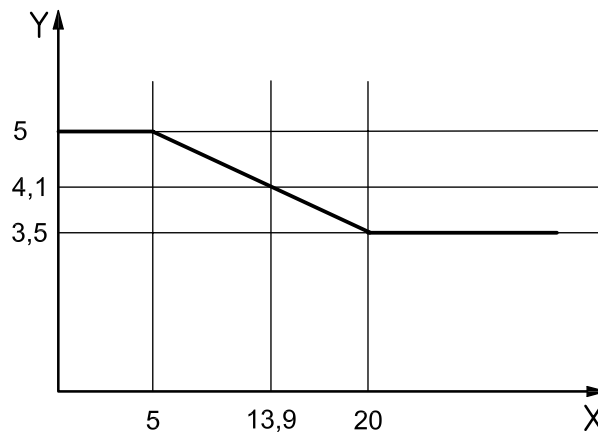

Key

X subject vehicle speed, expressed in m/s

Y maximum deceleration, expressed in m/s²

Figure 7 — Maximum deceleration

The average rate of change of automatic deceleration (negative jerk) shall not exceed 2,5 m/s³ (average over 1 s) when the vehicle is travelling above 20 m/s and 5 m/s³ (average over 1 s) when the vehicle is travelling below 5 m/s, as shown in Figure 8. The vehicle speed range 0 m/s to 13,9 m/s only applies to the LSF systems.

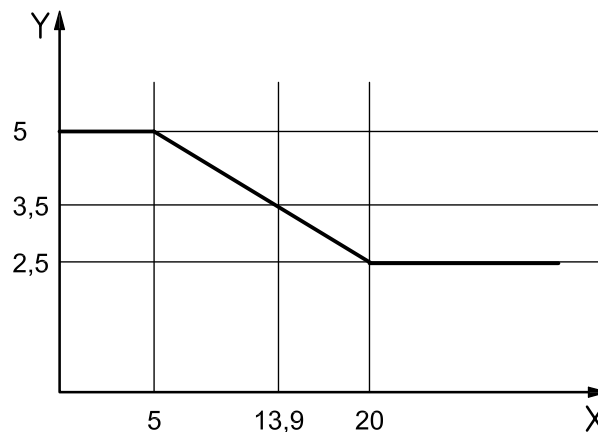

Key

X subject vehicle speed, expressed in m/s

Y negative jerk, expressed in m/s³

Figure 8 — Negative jerk

The average automatic acceleration of LSF systems shall not exceed 2 m/s² (average over 2 s) when the vehicle is travelling above 20 m/s and 4 m/s² (average over 2 s) when the vehicle is travelling below 5 m/s, as shown in Figure 9. The vehicle speed range 0 m/s to 13,9 m/s only applies to the LSF systems.

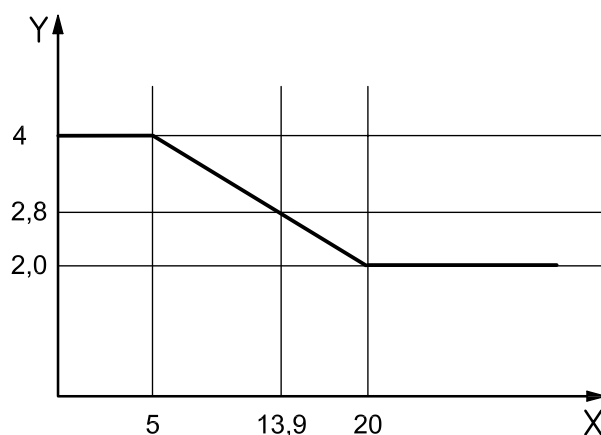

Key

- X subject vehicle speed, expressed in m/s
- Y automatic acceleration, expressed in m/s²

Figure 9 — Automatic acceleration

6.6 Activation of brake lights

If the LSF system applies automatic service braking, the brake lights shall be illuminated. When the LSF system applies other deceleration devices, the system may illuminate the brake lights. The brake lights shall be illuminated within 350 ms after the LSF system initiates the service brake. To prevent irritating brake light flickering, the brake light may remain on for a reasonable time after the LSF initiated braking has ended.

6.7 Failure reactions

Table 1 gives the required reactions to failures depending on which subsystem fails.

- The failures described in Table 1 shall result in immediate notification to the driver. The notification shall remain active until the system is switched off.
- The reactivation of the LSF system shall be prohibited until a successful self test, initiated by either ignition off/on or LSF-off/on, is accomplished.

Table 1 — Failure reactions for LSF

Failure in subsystem:		Failure occurs whilst LSF is applying:	
		Brake control	Engine control
1	Engine	Should maintain braking as required at least for the actual/current braking manoeuvre.	LSF engine control shall be relinquished.
2	Brake system ^a	LSF brake control shall be relinquished. If the brake system failure is not total during an active brake manoeuvre, the system may finish the current braking manoeuvre before the LSF control is relinquished completely.	LSF engine control shall be relinquished.
3	Detecting and ranging sensor	Should initiate a controller strategy starting with the last valid braking command. Braking shall not be released suddenly in this case. The system shall be switched off immediately after driver intervention by brake or accelerator pedal or LSF off switch.	LSF engine control shall be relinquished.
4	LSF controller	LSF brake control shall be relinquished.	LSF engine control shall be relinquished.
^a If a malfunction within the gear controller occurs, the brake will be able to handle the deceleration function.			

6.8 Combination with other systems

The LSF shall comply with the following requirements when combined with other longitudinal driving assistance systems.

- Combination with a system which does not conduct a vehicle control, such as FVCWS (see ISO 15623), shall be allowed.
- If a type 1 LSF system is installed in combination with a system that supports acceleration and deceleration in a normal driving condition, such as ACC (see ISO 15622), a transition between the LSF Active state and the Active state (or its equivalent) of the other system shall only be allowed by a manual driver operation.
- If a type 2 LSF system is installed in combination with a system that supports acceleration and deceleration in a normal driving condition, such as ACC (see ISO 15622), it shall be indicated to the driver which system is activated.
- In a combination with systems that conduct a collision avoidance control or collision mitigation in an emergency, the LSF system shall not interfere with the emergency operation of such systems.

7 Performance evaluation test methods

7.1 Environmental conditions

- a) Test location shall be on a flat, dry and clean asphalt or concrete surface.
- b) Temperature range shall be between $-20\text{ }^{\circ}\text{C}$ and $+40\text{ }^{\circ}\text{C}$.
- c) Horizontal visibility range shall be greater than 1 km.

7.2 Test target specification

7.2.1 General

The test targets are specified for technologies currently in use. For other technologies, representative test targets have to be used.

7.2.2 Infrared LIDAR

The infrared test target is defined by an infrared coefficient for test target CTT and the cross section of the test target.

The minimum cross section for test targets is 20 cm².

The test target is a diffuse reflector with a CTT = $(1 \pm 0,1)$ m²/sr.

7.2.3 Millimetre wave RADAR

The RADAR test target is defined by a RADAR cross section (RCS).

For the frequency range between 20 GHz and 95 GHz, the RCS for the test target shall be 3 m².

For significant different frequency ranges, the RCS shall be determined and defined.

7.3 Detection zone test

7.3.1 General

For the detection range on straight roads, see 6.2.3.

7.3.2 Test procedure for d_0 , d_1 and d_{max}

The vehicle reference plane corresponds to a rectangle of height 0,9 m by subject vehicle-width beginning at a height of 0,2 m. The detection area considers different places within the vehicle front-end plane. It is also restricted by the minimum height of passenger cars. The reference planes of d_1 and d_{max} are divided into 3 columns. The columns L and R have the width of 0,5 m each. During testing, the defined reflector shall be detected at least at one position within each column (L, C, R) of the vehicle reference plane at the position d_1 , d_{max} . At d_0 only one position within the whole reference plane has to be detected (see Figure 10).

- For the positions d_0 , d_1 and d_{max} , the test target (see 7.2) shall be used.
- Range testing should be done dynamically. As an option, static testing may be permissible.

The maximum detection time should not exceed 2 s after presentation of the target.

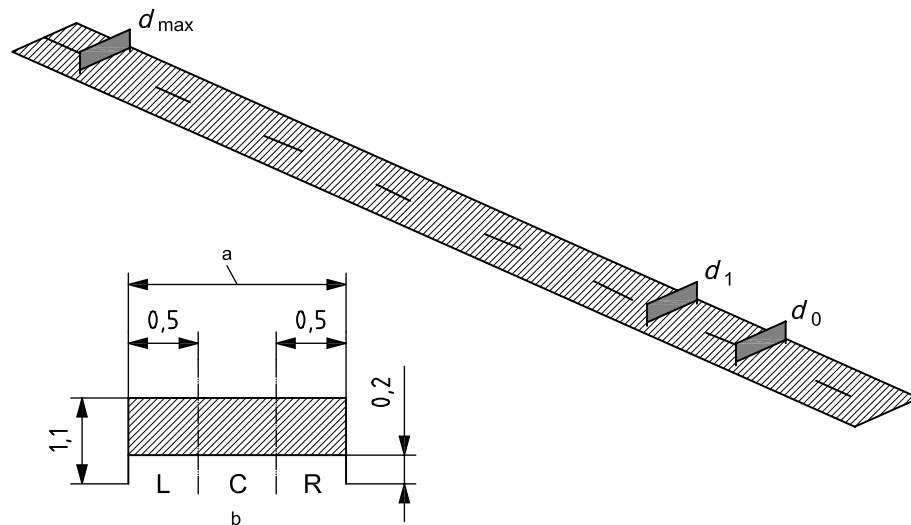

- a Subject vehicle width.
- b Vehicle reference plane.

Figure 10 — Longitudinal detection zones

7.4 Target discrimination test

7.4.1 General

For target discrimination, see 6.2.4.

7.4.2 Initial conditions

Two forward vehicles of the same model travel alongside each other at a speed of $v_{\text{vehicle_start}}$. The spacing between the longitudinal centrelines of the forward vehicles is $(3,5 \pm 0,25)$ m. The width of the forward vehicles shall be between 1,4 m and 2,0 m.

The subject vehicle follows one of the forward vehicles under a steady state condition. The forward vehicle that the subject vehicle follows is designated the target vehicle. The time gap = $\tau_{\text{max}}(v_{\text{vehicle_start}})$. The lateral displacement of the longitudinal centreline of the subject vehicle relative to the longitudinal centreline of the target vehicle shall be less than 0,5 m (see Figure 11).

Dimensions in metres

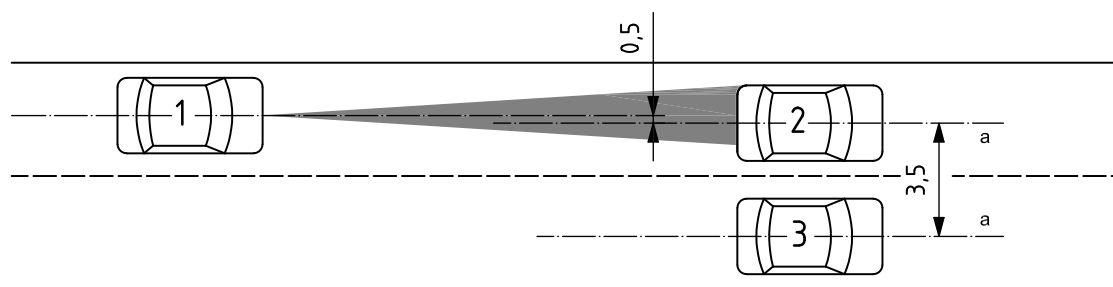

Key

- 1 subject vehicle
- 2 forward vehicle in the subject vehicle's path
- 3 forward vehicle in the adjacent lane

^a Each vehicle speed is $v_{\text{vehicle_end}}$.

Figure 11 — Discrimination test (initial conditions)

7.4.3 Test procedure

The target vehicle accelerates to $v_{\text{vehicle_end}}$.

The test is successfully fulfilled if the subject vehicle passes the forward vehicle in the adjacent lane while under LSF control (see Figure 12).

$$v_{\text{vehicle_end}} = v_{\text{max}}$$

$$v_{\text{vehicle_start}} = v_{\text{vehicle_end}} - 3 \text{ m/s}$$

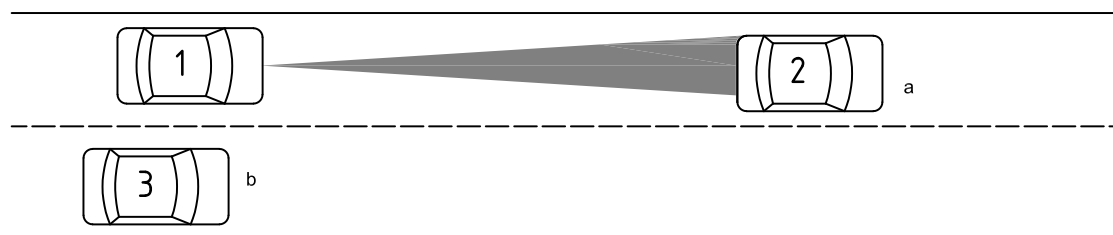

Key

- 1 subject vehicle
- 2 target vehicle
- 3 forward vehicle in the adjacent lane

^a Target vehicle speed is $v_{\text{vehicle_end}}$.

^b Forward vehicle speed in the adjacent lane is $v_{\text{vehicle_start}}$.

Figure 12 — Discrimination test (end conditions)

7.5 Automatic deceleration test

7.5.1 General

For car-following capability, see 6.3.2.

7.5.2 Initial conditions

A forward vehicle shall travel at a speed of $v_{\max} \begin{smallmatrix} 0 \\ -10 \end{smallmatrix}$ % (see Figure 13).

The width of the forward vehicle shall be within a range between 1,4 m and 2,0 m.

The subject vehicle follows behind the vehicle under a steady state condition.

The time gap shall be the value $\tau_{\min}(v_{\max})$.

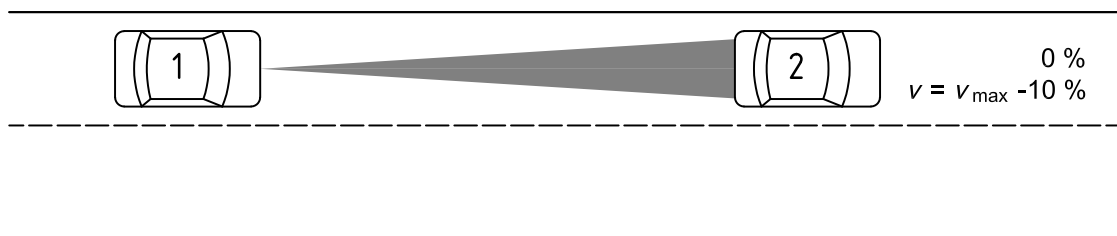

Key

- 1 subject vehicle
- 2 forward vehicle

Figure 13 — Automatic deceleration test (initial conditions)

7.5.3 Test procedure

The target vehicle shall decelerate to a stop.

The deceleration rate of the target vehicle shall be the value $(2,5 \begin{smallmatrix} 0 \\ -0,5 \end{smallmatrix})$ m/s².

The test is considered to be successfully completed when the subject vehicle under LSF control decelerates to v_{\min} behind the target vehicle (see Figure 14).

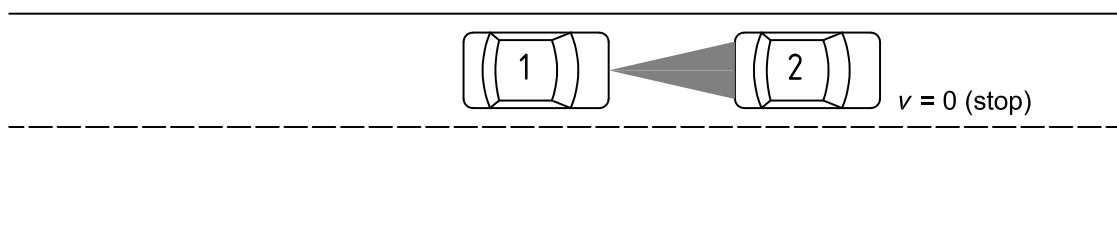

Key

- 1 subject vehicle
- 2 target vehicle

Figure 14 — Automatic deceleration test (end conditions)

7.6 Automatic retargeting capability test (type 2 LSF system only)

7.6.1 General

For automatic retargeting capability, see 6.3.3.

7.6.2 Initial conditions

A forward vehicle shall travel at a speed of $v_{\max} - 10\%$.

The width of the forward vehicle shall be within a range between 1,4 m and 2,0 m.

The subject vehicle follows the forward vehicle under a steady state condition.

The forward vehicle that the subject vehicle follows is designated the target vehicle.

The time gap shall be the value $\tau_{\min}(v_{\max})$.

The lateral displacement of the subject vehicle's longitudinal centreline relative to the target vehicle's longitudinal centreline shall be less than 0,5 m (see Figure 15).

Dimensions in metres

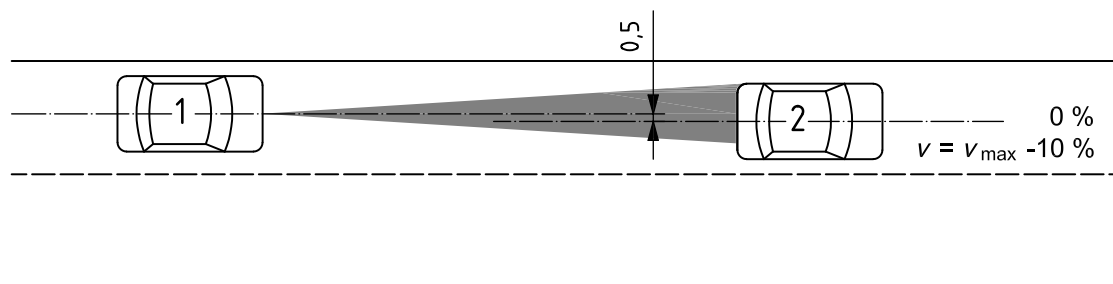

Key

- 1 subject vehicle
- 2 target vehicle

Figure 15 — Automatic retargeting capability test (initial conditions)

7.6.3 Test procedure

A low speed moving vehicle shall travel at a speed of 1,4 m/s to 2,8 m/s.

The target vehicle shall change lanes when detecting a low speed moving vehicle (see Figure 16).

The location of the lane change shall be the value obtained by multiplying $v_{\max} - 10\%$ by 3,0 s.

The lateral displacement of the subject vehicle's longitudinal centreline relative to the low speed moving vehicle's longitudinal centreline shall be less than 0,5 m.

The test is considered to be successfully completed when the subject vehicle under LSF control follows behind the low speed moving vehicle with an appropriate clearance (see Figure 17).

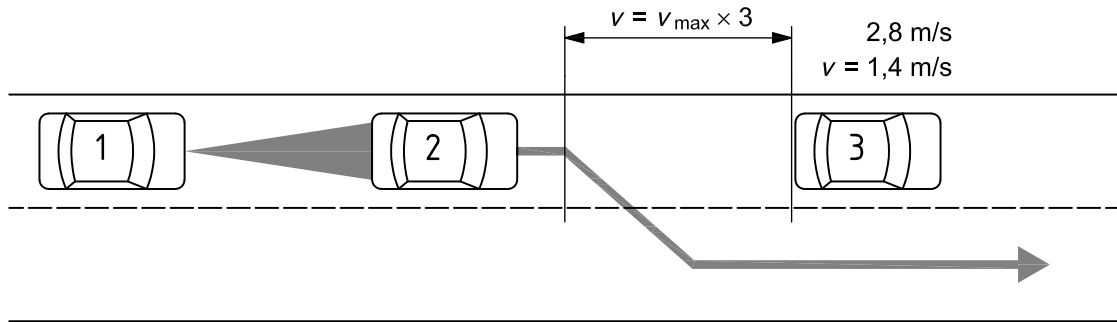

Key

- 1 subject vehicle
- 2 target vehicle
- 3 low speed moving vehicle

Figure 16 — Automatic retargeting capability test (lane-change conditions)

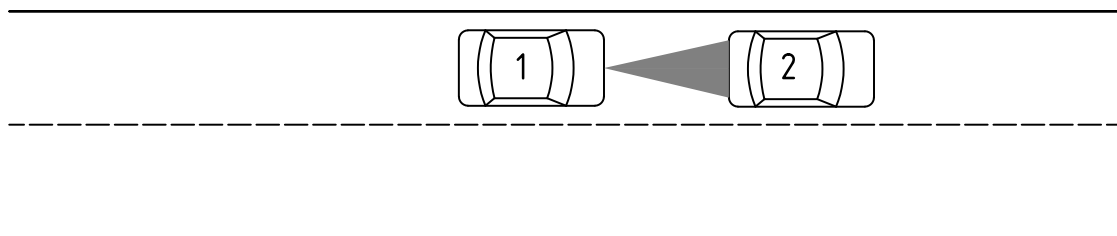

Key

- 1 subject vehicle
- 2 low speed moving vehicle

Figure 17 — Automatic retargeting capability test (end conditions)

7.7 Curve capability test

7.7.1 General

This test should take into consideration the road geometry prediction in combination with the field of view of the LSF system's sensor.

Different methods of road geometry prediction and headway sensing result in the need for a driving scenario.

7.7.2 Test field

The test track shall consist of either circular track of constant radius or a sufficiently long segment of curve of constant radius. The radius should be within 80 % to 100 % of R_{min} . The direction of travel on the track shall be both clockwise and counter clockwise. There is no restriction concerning lane markings, guard rails, etc. (see Figure 18).

For LSF systems, the tests shall be done for $R_{min} = 125$ m.

Dimensions in metres

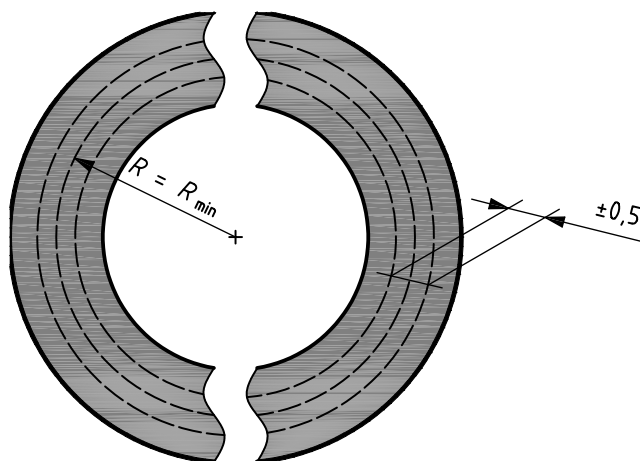

Figure 18 — Outline test track

7.7.3 Curve capability target vehicle

The target vehicle shall be provided with the test target as defined in 7.2. The test target shall be placed in the middle on the rear end of the vehicle at a height of $(0,6 \pm 0,1)$ m above ground. The remaining exposed vehicle surface shall be concealed in such a way that the rear surface, with the test target removed, represents an RCS of no greater than $0,6 \text{ m}^2$ or a reflectivity of no greater than 20 % of the test target.

7.7.4 Driving scenario

The subject vehicle follows the target vehicle along the same path ($\pm 0,5$ m lateral separation as measured from the centrelines of both vehicles) under steady state condition. The two cars shall conform to the test start conditions as defined in Figure 15 (subject and target vehicle only) prior to the start of the test. Details of the test are given in Tables 2 and 3 and Figure 19.

The speed of the target vehicle at the start of the test is given by:

$$v_{\text{circle_start}} = v_{\text{max}} - 10 \%$$

At the proper time, the target vehicle decelerates and the reaction of the subject vehicle is observed. The subject vehicle shall start to decelerate due to the decreasing distance to the target vehicle before the time gap falls below $2/3 \tau_{\text{max}}$ (see Figure 20).

Table 2 — Test conditions for the curve capability test (target vehicle)

	Test preliminary	Test start conditions	1st test manoeuvre	2nd test manoeuvre
Speed	constant = $v_{\text{circle_start}}$		decrease speed by $3,5 \text{ m/s} \pm 0,5 \text{ m/s}$	constant = $v_{\text{circle_start}} - 3,5 \text{ m/s} \pm 1 \text{ m/s}$
Time	$\geq 10 \text{ s}$	time trigger 0 s	2 s	—
Radius	$\geq R$ as defined in 7.7.2; may vary	$R = \text{constant}$ (see 7.7.2)		

Table 3 — Test conditions for the curve capability test (subject vehicle)

	Test preliminary	Test start conditions	1st test manoeuvre	2nd test manoeuvre
Speed	as controlled by LSF			
Acceleration	$\leq 0,5 \text{ m/s}^2$		deceleration to be observed	
Radius	$\geq R$ as defined in 7.7.2; may vary	$R = \text{constant}$ (see 7.7.2)		
Time gap to target vehicle	$\tau_{\text{max}} (v_{\text{circle_start}}) \pm 25 \%$		as controlled by LSF; shall be observed	

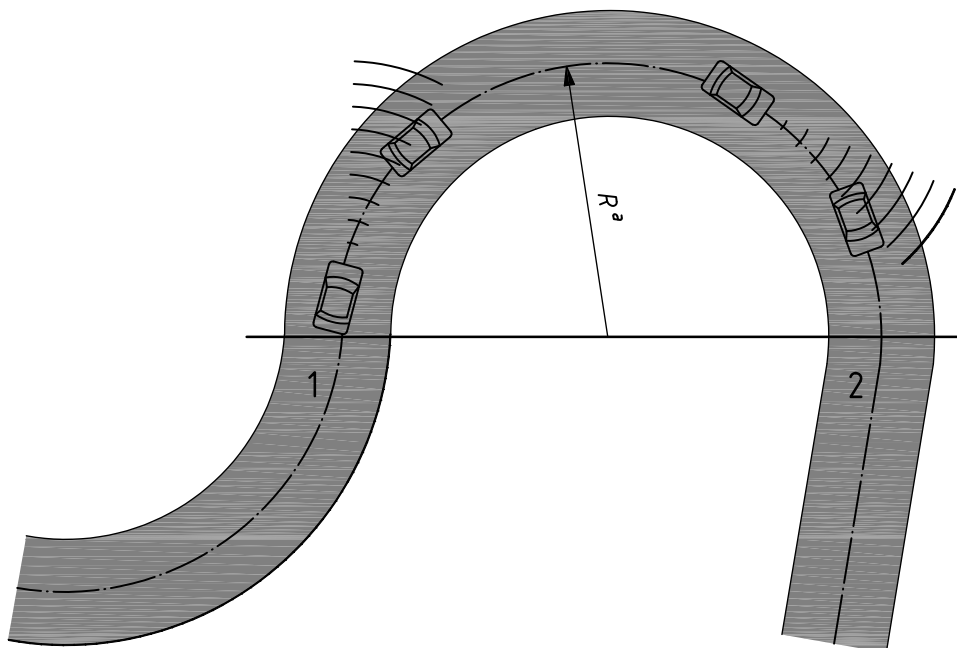

Key

- 1 test start (subject vehicle is on a part of the track with constant radius and complies with the other test start conditions)
- 2 test end [subject vehicle decelerates (positive result) or the time gap falls below $2/3 \tau_{\text{max}}$]

^a Constant.

Figure 19 — Example of test track layout

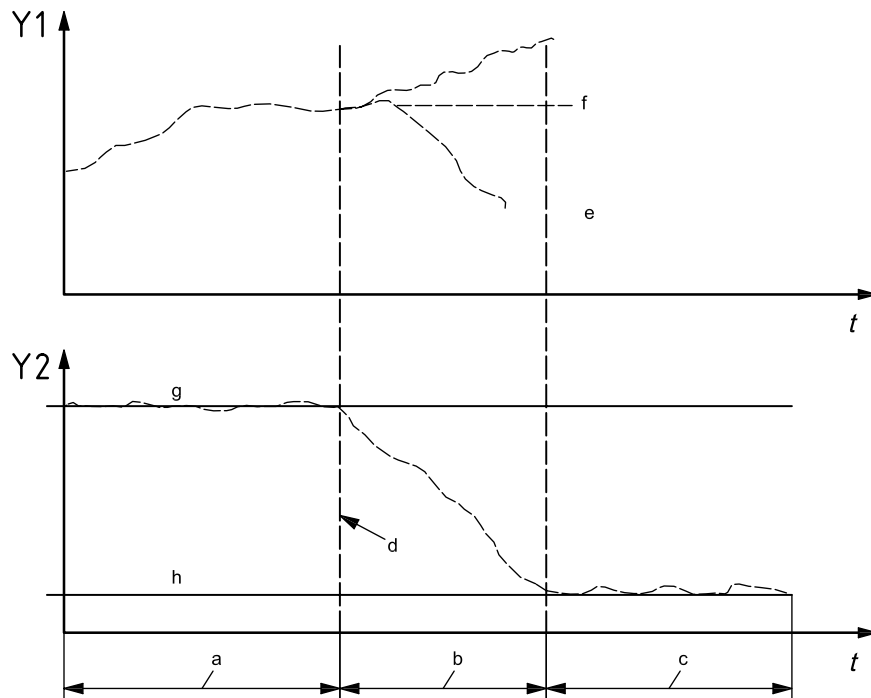

Key

- t test time
- Y1 subject vehicle speed
- Y2 target vehicle speed

- a Test preliminary.
- b First test manoeuvre.
- c Second test manoeuvre.
- d Test start.
- e Positive results.
- f Negative results.
- g Target vehicle speed is $v_{\text{circle_start}}$.
- h Target vehicle speed is $v_{\text{circle_start}} - 3,5 \text{ m/s}$.

Figure 20 — Timing of curve capability test

Annex A (normative)

Technical information

A.1 LIDAR — Coefficient of test target

A.1.1 Solid angle, Ω

The solid angle, Ω , is the ratio of the irradiated portion of the surface of light to the square of the radius of the sphere (see Figure A.1).

$$\Omega = \frac{A}{d_A^2} \times \Omega_0$$

where

Ω is the solid angle (sr);

A is the utilized area (m²);

d_A is the distance between source and projected area A (m);

Ω_0 is the solid angle of the source (1 sr).

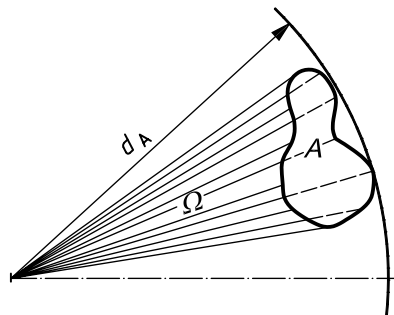

Figure A.1 — Solid angle

A.1.2 Radiated intensity, I

The radiated intensity, I , is given by the radiated power from a radiation source, Φ , inside a solid angle, Ω .

$$I_{\text{ref}} = \frac{d\Phi_{\text{ref}}}{d\Omega_1}$$

where

I_{ref} is the radiated intensity in a given direction, out of the reflector, measured in front of the receiver surface (W/sr);

Φ_{ref} is the radiated power (W);

Ω_1 is the illuminated solid angle (sr).

A.1.3 Intensity of irradiation, E_t

Intensity of irradiation is the ratio of the incident radiated power to the area of illuminated surface. E_t is the density by surface of the illumination.

$$E_t = \frac{d\Phi_t}{dA_t}$$

where

E_t is the intensity of irradiation (W/m²);

Φ_t is incident radiated power (W);

A_t is illuminated surface (m²).

A.1.4 Coefficient for test target (CTT)

The test target is defined by a coefficient of a reflector, which represents the reflectivity of a dirty car without any retro-reflector.

$$\text{CTT} = \frac{I_{\text{ref}}}{E_t}$$

where

CTT is the coefficient for the test target, in square metres per steradian (m²/sr);

I_{ref} is the radiated intensity in a given direction, out of the reflector, measured in front of the receiver surface (W/sr);

E_t is the intensity of irradiation, out of the transmitter (W/m²).

The reflector (see Figure A.2) with the defined CTT shall have a spatial distribution of the reflection $\geq 8 \times 10^{-3}$ sr.

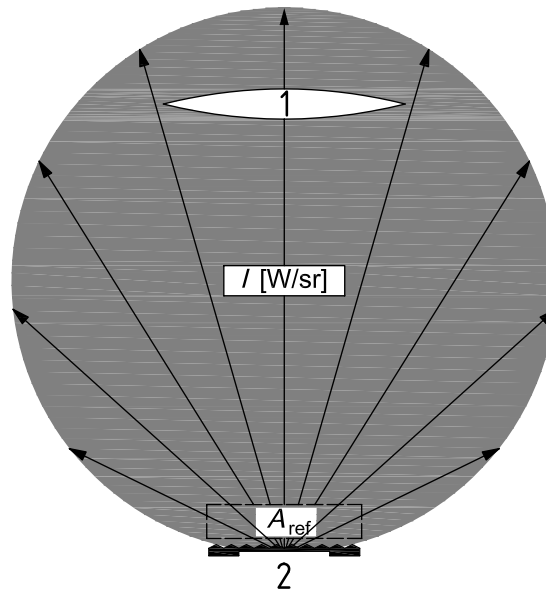

Key

- 1 receiver
- 2 reflector

Figure A.2 — Receiver scenario

The CTT only describes the quality of a reflector (damping). For the test procedure, it is sufficient to have a corner reflector (see Figure A.3) (reduction of the surface to “a point”). However, it is also possible to have a larger surface of reflection if the whole reflectivity of the reflector surface does not exceed the mentioned value.

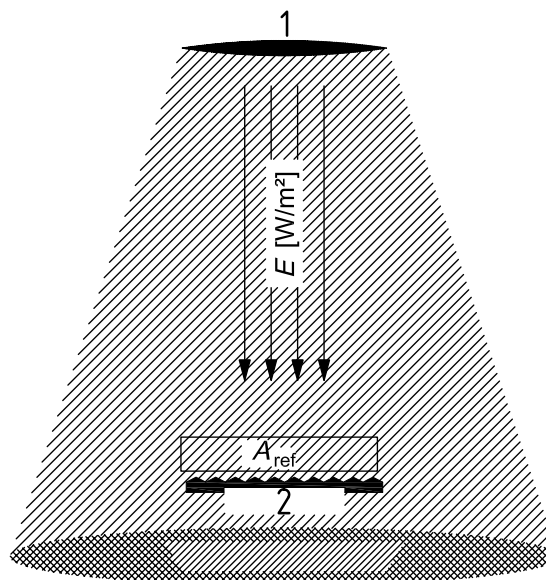

Key

- 1 transmitter
- 2 reflector

Figure A.3 — Transmitter scenario

A.1.5 Reflector size

The size of the reflector (see Figure A.4) shall be defined. Experience shows that a Lambert reflector with a size of approximately 1,7 m² is the ideal solution in case of vehicle representation. A different method could be a 'triple' reflector with a size of approximately 20 cm².

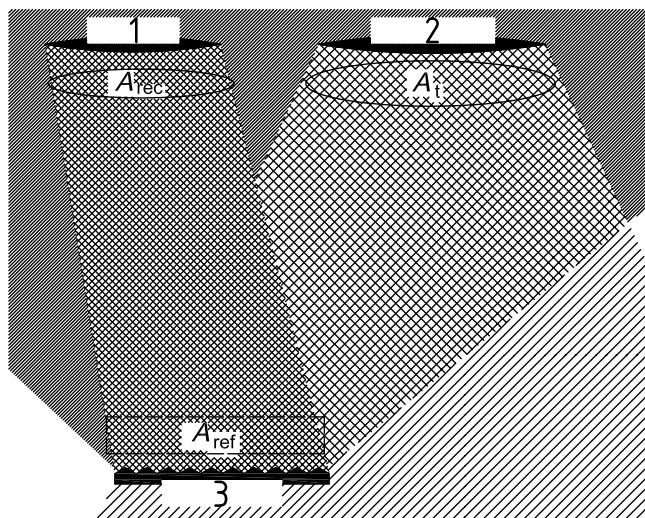

Key

- 1 receiver
- 2 transmitter
- 3 reflector

Figure A.4 — Reflector scenario

The Lambert reflector reflects the whole energy inside a sphere area (see Figure A.5).

$$\Phi_{\oplus} = \pi \times I_0 \times \Omega_0$$

where

Φ_{\oplus} is the radiated power (W);

I_0 is the radiated intensity (W/sr);

Ω_0 is the solid angle (sr).

A size of 1,7 m² represents the cross-section of a small vehicle.

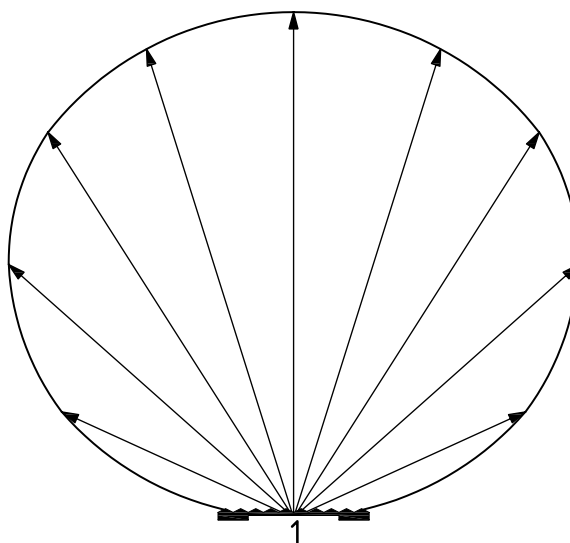

Key

1 reflector

Figure A.5 — Lambert reflector

A.2 Definition of the RCS of a corner cube type test target

The test target is defined by an RCS.

Aspect of test target should be as shown in Figure A.6.

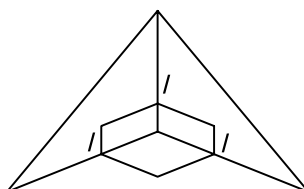

Figure A.6 — Corner cube reflector

$$\text{RCS} = \frac{4 \times \pi \times l^4}{3 \times \lambda^2}$$

where

l is the length of a side of a RADAR test reflector (m);

λ is the wavelength (m).

Bibliography

- [1] ISO 15622, *Transport information and control systems — Adaptive Cruise Control Systems — Performance requirements and test procedures*
- [2] ISO 15623, *Transport information and control systems — Forward vehicle collision warning systems — Performance requirements and test procedures*

ICS 43.040.15

Price based on 28 pages

BSI - British Standards Institution

BSI is the independent national body responsible for preparing British Standards. It presents the UK view on standards in Europe and at the international level. It is incorporated by Royal Charter.

Revisions

British Standards are updated by amendment or revision. Users of British Standards should make sure that they possess the latest amendments or editions.

It is the constant aim of BSI to improve the quality of our products and services. We would be grateful if anyone finding an inaccuracy or ambiguity while using this British Standard would inform the Secretary of the technical committee responsible, the identity of which can be found on the inside front cover. Tel: +44 (0)20 8996 9000. Fax: +44 (0)20 8996 7400.

BSI offers members an individual updating service called PLUS which ensures that subscribers automatically receive the latest editions of standards.

Buying standards

Orders for all BSI, international and foreign standards publications should be addressed to Customer Services. Tel: +44 (0)20 8996 9001. Fax: +44 (0)20 8996 7001 Email: orders@bsigroup.com You may also buy directly using a debit/credit card from the BSI Shop on the Website <http://www.bsigroup.com/shop>

In response to orders for international standards, it is BSI policy to supply the BSI implementation of those that have been published as British Standards, unless otherwise requested.

Information on standards

BSI provides a wide range of information on national, European and international standards through its Library and its Technical Help to Exporters Service. Various BSI electronic information services are also available which give details on all its products and services. Contact Information Centre. Tel: +44 (0)20 8996 7111 Fax: +44 (0)20 8996 7048 Email: info@bsigroup.com

Subscribing members of BSI are kept up to date with standards developments and receive substantial discounts on the purchase price of standards. For details of these and other benefits contact Membership Administration. Tel: +44 (0)20 8996 7002 Fax: +44 (0)20 8996 7001 Email: membership@bsigroup.com

Information regarding online access to British Standards via British Standards Online can be found at <http://www.bsigroup.com/BSOL>

Further information about BSI is available on the BSI website at <http://www.bsigroup.com>

Copyright

Copyright subsists in all BSI publications. BSI also holds the copyright, in the UK, of the publications of the international standardization bodies. Except as permitted under the Copyright, Designs and Patents Act 1988 no extract may be reproduced, stored in a retrieval system or transmitted in any form or by any means – electronic, photocopying, recording or otherwise – without prior written permission from BSI.

This does not preclude the free use, in the course of implementing the standard, of necessary details such as symbols, and size, type or grade designations. If these details are to be used for any other purpose than implementation then the prior written permission of BSI must be obtained.

Details and advice can be obtained from the Copyright and Licensing Manager. Tel: +44 (0)20 8996 7070 Email: copyright@bsigroup.com