



BSI Standards Publication

Smoke and heat control systems

Part 7: Smoke ducts sections

National foreword

This British Standard is the UK implementation of ISO 21927-7:2017.

The UK participation in its preparation was entrusted to Technical Committee FSH/25, Smoke, heat control systems and components.

A list of organizations represented on this committee can be obtained on request to its secretary.

This publication does not purport to include all the necessary provisions of a contract. Users are responsible for its correct application.

ISBN 978 0 580 84641 0

ICS 13.220.20

Compliance with a British Standard cannot confer immunity from legal obligations.

This British Standard was published under the authority of the Standards Policy and Strategy Committee on 31 May 2017.

Amendments/corrigenda issued since publication

Date	Text affected
------	---------------

INTERNATIONAL
STANDARD

ISO
21927-7

First edition
2017-04-01

Smoke and heat control systems —
Part 7:
Smoke ducts sections

Systèmes pour le contrôle des fumées et de la chaleur —
Partie 7: Sections des conduits de désenfumage



Reference number
ISO 21927-7:2017(E)



COPYRIGHT PROTECTED DOCUMENT

© ISO 2017, Published in Switzerland

All rights reserved. Unless otherwise specified, no part of this publication may be reproduced or utilized otherwise in any form or by any means, electronic or mechanical, including photocopying, or posting on the internet or an intranet, without prior written permission. Permission can be requested from either ISO at the address below or ISO's member body in the country of the requester.

ISO copyright office
Ch. de Blandonnet 8 • CP 401
CH-1214 Vernier, Geneva, Switzerland
Tel. +41 22 749 01 11
Fax +41 22 749 09 47
copyright@iso.org
www.iso.org

Contents

Page

Foreword	iv
Introduction	v
1 Scope	1
2 Normative references	1
3 Terms and definitions	1
4 Smoke control duct section requirements	3
4.1 General.....	3
4.1.1 Fire resistance — multi-compartment smoke control duct section.....	3
4.1.2 Fire resistance — single compartment smoke control duct section.....	4
4.2 Construction and components: Characteristics.....	4
4.2.1 Construction and operation.....	4
4.2.2 Structural supports used for smoke control duct sections.....	4
4.2.3 Duct sealant materials used in or between smoke control duct sections.....	4
4.2.4 Penetration seals between fire compartments.....	4
4.2.5 Other components.....	5
4.3 Fire resistance performance criteria: Multi-compartment fire resisting smoke control duct sections.....	5
4.3.1 Integrity, insulation, leakage.....	5
4.3.2 Fire resistance classification and designation.....	6
4.4 Fire resistance performance criteria: Single compartment smoke control duct sections.....	6
4.4.1 Integrity, leakage.....	6
4.4.2 Fire resistance classification and designation.....	6
5 Test methods	7
5.1 Ambient leakage tests.....	7
5.2 Fire resistance tests.....	7
5.2.1 General.....	7
5.2.2 Smoke control duct section: integrity and insulation.....	7
5.2.3 Leakage rated smoke control duct section.....	8
6 Marking and documentation	8
7 Product, installation and maintenance information (documentation)	8
7.1 Product specification.....	8
7.2 Installation information.....	8
7.3 Maintenance information.....	9
Annex A (informative) Example of inspection and maintenance procedure	10
Bibliography	11

Foreword

ISO (the International Organization for Standardization) is a worldwide federation of national standards bodies (ISO member bodies). The work of preparing International Standards is normally carried out through ISO technical committees. Each member body interested in a subject for which a technical committee has been established has the right to be represented on that committee. International organizations, governmental and non-governmental, in liaison with ISO, also take part in the work. ISO collaborates closely with the International Electrotechnical Commission (IEC) on all matters of electrotechnical standardization.

The procedures used to develop this document and those intended for its further maintenance are described in the ISO/IEC Directives, Part 1. In particular the different approval criteria needed for the different types of ISO documents should be noted. This document was drafted in accordance with the editorial rules of the ISO/IEC Directives, Part 2 (see www.iso.org/directives).

Attention is drawn to the possibility that some of the elements of this document may be the subject of patent rights. ISO shall not be held responsible for identifying any or all such patent rights. Details of any patent rights identified during the development of the document will be in the Introduction and/or on the ISO list of patent declarations received (see www.iso.org/patents).

Any trade name used in this document is information given for the convenience of users and does not constitute an endorsement.

For an explanation on the voluntary nature of standards, the meaning of ISO specific terms and expressions related to conformity assessment, as well as information about ISO's adherence to the World Trade Organization (WTO) principles in the Technical Barriers to Trade (TBT) see the following URL: www.iso.org/iso/foreword.html.

This document was prepared by Technical Committee ISO/TC 21, *Equipment for fire protection and fire fighting*, Subcommittee SC 11, *Smoke and heat control systems and components*.

A list of all parts in the ISO 21927 series can be found on the ISO website.

Introduction

This document contains the basic performance and requirements for smoke control duct sections, which are to be used in conjunction with pressure differential systems and smoke and heat control systems. They may also be used to pressurize when gas extinguishing systems are used.

Particular reference is made to EN 1366-8 and EN 1366-9, which define the fire resistance testing associated with these products and EN 13501-4, which provides details on their fire resistance classification.

In addition to the prevention of transmission of smoke and combustion products from a fire zone, smoke control duct sections are utilized to contain the spillage of otherwise harmful and toxic extinguishing gases from the affected area, and for the control of pressurizing and excess air relief within pressurization systems.

Smoke control systems are designed to fulfil three basic functions.

- a) The extraction of smoke from a single fire compartment to the outside of the building.
- b) The extraction of smoke from fire compartments of a building, using a SHEVS connected to one or more fire compartments. The smoke control duct may or may not pass through other compartments of the building to reach the outside of the building.
- c) The use of pressurization to maintain smoke free clear areas.

Smoke control ducts are commonly used in smoke and heat control systems. They may serve single compartments or a number of different fire compartments. The systems may be dedicated smoke extraction or possibly a combined environmental ventilation/smoke extraction.

The smoke and heat control system may remove smoke using either high temperature fans (in accordance with ISO 21927-3) or natural ventilators (in accordance with ISO 21927-2).

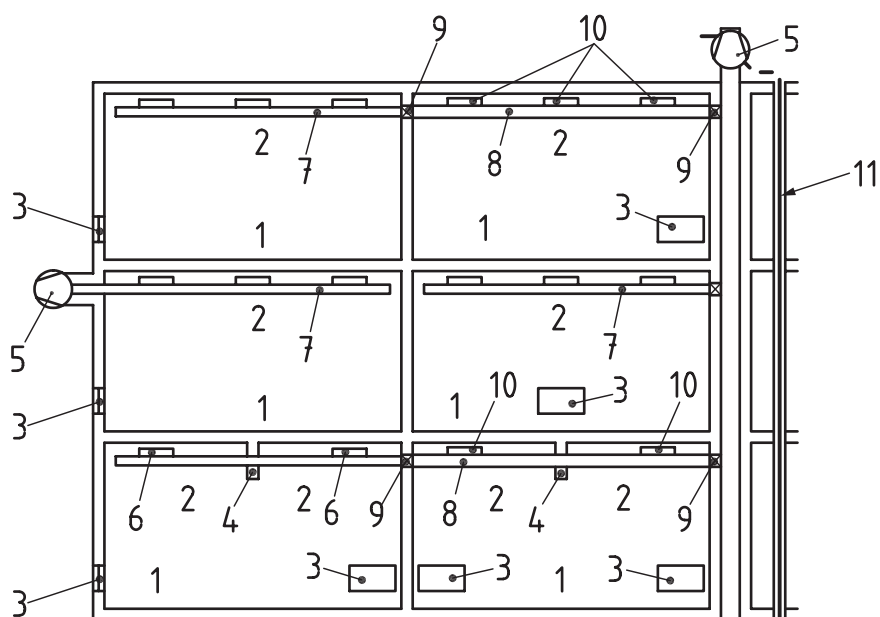

Key

- 1 fire compartment
- 2 smoke reservoir
- 3 air inlet
- 4 smoke barrier
- 5 powered smoke and heat exhaust ventilator (fan)
- 6 smoke control dampers for single compartments
- 7 smoke control duct sections for single compartments
- 8 smoke control duct sections for multi compartments
- 9 smoke control dampers for multi compartments mounted inside or outside of wall or floor
- 10 smoke control dampers for multi compartments mounted on the surface of the duct
- 11 electrical equipment

Figure 1 — Example of powered smoke and heat exhaust ventilation

Further guidance on the application of smoke control ducts may be found within the rest of the EN 12101 series and technical reports.

The areas for which products supplied to this document are considered applicable include, for example,

- a) commercial premises,
- b) shopping and retail centres,
- c) hospitals, and
- d) multi-residential buildings.

Smoke control duct sections are intended for use in the following types of systems, including

- 1) pressurization,
- 2) pressure relief,
- 3) extraction systems,
- 4) ductwork systems, and

5) inerting fire suppression systems.

It is realized that all the above systems do not address smoke directly, but similar properties are required of such smoke control ducts to limit leakage in a fire and smoke control situation.

Smoke and heat control systems —

Part 7: Smoke ducts sections

1 Scope

This document applies to smoke control duct sections placed on the market and intended to operate as part of a pressure differential system or smoke and heat exhaust system. This document specifies requirements and gives reference to the test methods defined for smoke control duct sections and their associated components (for example, hangers and other items proven at the time of testing), which are intended to be installed in such systems in buildings. Furthermore, marking and information on installation and maintenance of these products are also given in this document.

NOTE To avoid duplication, reference is made to a variety of other standards. To this end, this document can be read in conjunction with EN 1366-8, EN 1366-9 and ISO 6944-1, for details of the fire resistance testing and EN 13501-4 for corresponding classification.

This document has not considered in detail the detrimental and/or corrosive effects that may be caused by process chemicals present in the atmosphere, which are drawn through the system intentionally or inadvertently.

This document also governs associated components used together with smoke control duct sections such as turning vanes and silencers, with the exception of natural and powered smoke ventilators and smoke control dampers, which are covered by separate standards.

Ducts for use other than in smoke and heat exhaust/control systems are not covered by this document.

2 Normative references

The following documents are referred to in the text in such a way that some or all of their content constitutes requirements of this document. For dated references, only the edition cited applies. For undated references, the latest edition of the referenced document (including any amendments) applies.

ISO 13943, *Fire safety — Vocabulary*

EN 1366-8, *Fire resistance tests for service installations — Part 8: Smoke extraction ducts*

EN 1366-9, *Fire resistance tests for service installations — Part 9: Single compartment smoke extraction ducts*

EN 13501-4, *Fire classification of construction products and building elements — Part 4: Classification using data from fire resistance tests on components of smoke control systems*

3 Terms and definitions

For the purposes of this document, the terms and definitions given in ISO 13943 and the following apply.

ISO and IEC maintain terminological databases for use in standardization at the following addresses:

- IEC Electropedia: available at <http://www.electropedia.org/>
- ISO Online browsing platform: available at <http://www.iso.org/obp>

3.1

air inlet

device connected to outside air to allow the entry of air from outside the construction works

3.2

elevated temperature

temperatures in excess of normal ambient air, below those necessary for fire resistance testing, to which smoke and heat exhaust ducts for single compartments are tested

3.3

fire compartment

enclosed space comprising one or more separate spaces, bounded by elements of construction having a specified fire resistance and intended to prevent the spread of fire (in either direction) for a given period of time

3.4

natural smoke and heat control system

smoke and heat ventilation system which uses natural ventilation

Note 1 to entry: Natural ventilation is caused by buoyancy forces due to differences in density of the gases because of temperature differences.

3.5

penetration seal

product used between the smoke control duct and the fire compartment boundary structure to maintain the fire resistance, when tested and having met the requirements of EN 1366-8, at the position where a smoke control duct passes through the element

3.6

powered smoke and heat exhaust system

smoke and heat ventilation system which utilizes a number of hot gas fans that are suitable for handling hot gases for a limited period of time which causes the positive displacement of gases

3.7

pressure differential systems

system of fans, ducts, vents and other features provided for the purposes of creating a lower pressure in the fire zone than in the protected space

3.8

smoke and heat exhaust ventilation system

SHEVS

system consisting of products and/or components jointly selected to exhaust smoke and heat

Note 1 to entry: The products and/or components form a system in order to establish a buoyant layer of warm gases above cooler cleaner air.

3.9

smoke and heat exhaust ventilator

SHEV

device specially designed to move smoke and hot gases out of a construction works under conditions of fire

3.10

smoke barrier

obstruction to restrict the spread of smoke and hot gases from a fire, forming part of the boundary of a smoke reservoir or used as a channelling screen, or used as a void edge boundary

3.11

smoke control damper

device automatically or manually activated, which may be open or closed in its operational position, to control the flow of smoke and hot gases into, from or within a duct

3.12

smoke control duct

<horizontal> smoke control duct which passes horizontally through vertical walls

3.13

smoke control duct

<multi-compartment fire resisting> fire resisting smoke control ducts built from more than one smoke control duct section for use in multi-compartment applications designed to transport smoke and/or hot gases away from the source of a fire

Note 1 to entry: May also have a dual function as a normal air conditioning duct.

3.14

smoke control duct

<single compartment> smoke control ducts built from more than one smoke control duct section for use within single fire compartment application designed to transport smoke and/or hot gases away from the source of a fire

Note 1 to entry: May also have a dual function as a normal air conditioning duct.

3.15

smoke control duct

<section> element of smoke control duct constructed to form part of a smoke control system

3.16

smoke control duct

<vertical> smoke control duct which passes vertically through horizontal floors

3.17

smoke layer

covering of smoke that stabilizes underneath the roof due to the effect of temperature gradient

3.18

smoke reservoir

region within a building limited or bordered by smoke barriers or structural elements and which will, in the event of a fire, retain a thermally buoyant smoke layer

3.19

smoke zone

structural supports

means of retaining the smoke control duct to the building structure

4 Smoke control duct section requirements

4.1 General

4.1.1 Fire resistance — multi-compartment smoke control duct section

The multi-compartment smoke control duct section shall demonstrate the following and shall be classified in accordance with EN 13501-4:

- a) integrity: this shall be tested in accordance with the test method in [5.2](#) and the integrity classification (E) declared;
- b) insulation: this shall be tested in accordance with the test method in [5.2](#) and the insulation classification (I) declared;
- c) leakage: this shall be tested in accordance with the test method in [5.2](#) and the leakage classification (S) declared;

- d) mechanical stability: this shall be tested in accordance with the test method in [5.2](#) and forms part of the integrity classification (E) declared;
- e) maintenance of cross section: this shall be tested in accordance with the test method in [5.2](#) and forms part of the integrity classification (E) declared.

4.1.2 Fire resistance — single compartment smoke control duct section

The single compartment smoke control duct section shall demonstrate the following and shall be classified in accordance with EN 13501-4:

- a) integrity: this shall be tested in accordance with the test method in [5.2](#) and the integrity classification (E) declared;
- b) leakage: this shall be tested in accordance with the test method in [5.2](#) and the leakage classification (S) declared;
- c) mechanical stability: this shall be tested in accordance with the test method in [5.2](#) and forms part of the integrity classification (E) declared;
- d) maintenance of cross-section: this shall be tested in accordance with the test method in [5.2](#) and forms part of the integrity classification (E) declared.

4.2 Construction and components: Characteristics

4.2.1 Construction and operation

Smoke control ducts are required to maintain a clear path for the extract of smoke and heat. To achieve this, the following shall be considered part of the smoke control duct section assembly and their performance in the tests shown in [5.2](#) recorded.

4.2.2 Structural supports used for smoke control duct sections

Structural supports used for smoke control duct sections ensure the mechanical stability and maintenance of cross-section. Full details of the structural supports used for the fire test shall be recorded.

4.2.3 Duct sealant materials used in or between smoke control duct sections

Sealants are often used to reduce the air/gas leakage from smoke and heat exhaust ventilation systems. Failure of these sealants while the smoke and heat exhaust ventilation system is operating in its emergency mode may result in the failure of the duct's leakage criteria. Full details of the sealants used for the fire test shall be recorded.

The following general requirements for duct sealants shall apply.

- a) The sealants shall be suitable for the environment to which the smoke control duct is to be subject.
- b) The sealants shall be durable for the proposed life of the smoke control duct section.
- c) The sealants shall be resistant to mechanical damage during the installation of the smoke control duct section.
- d) Any deterioration of the sealant shall not cause the smoke control duct section to fail the leakage criteria for the duct classification.

4.2.4 Penetration seals between fire compartments

Penetration seals are required to reduce the air/gas leakage between compartments. Failure of these penetration seals, whilst the smoke and heat control system is operating in its emergency mode, may

result in the failure of the system to maintain smoke-free areas. Full details of the penetration seals used for the fire test shall be recorded.

The following general requirements for penetration seals shall apply.

- a) Penetration seals shall maintain the integrity and insulation criteria of the smoke control duct.
- b) The gap dimension between the inside edge of the supporting construction and the outer perimeter of the smoke control duct section, and hence the sealing details, shall follow the tested method when the smoke control duct section is installed within a building.

4.2.5 Other components

Smoke control ducts often contain other components than structural supports and sealants. These shall not cause failure of the smoke extraction system whilst exhausting smoke from the building and shall be tested to meet the same requirements as the duct into which they are installed. Full details of any components used for the fire test shall be recorded.

Among these components may be the following equipment:

- access doors/panels;
- silencers or attenuators to limit noise;
- compensators;
- turning vanes;
- air flow/volume indication transponders;
- grilles, to control the direction of air/smoke movement at the terminals of the system.

Components shall be tested according to the principles of EN 1366-8 or EN 1366-9 to prove that they do not reduce the performance of the smoke control duct section already tested and classified. They shall be installed in accordance with the manufacturer's instructions for the component and any associated smoke control duct section.

4.3 Fire resistance performance criteria: Multi-compartment fire resisting smoke control duct sections

4.3.1 Integrity, insulation, leakage

The assessment of integrity (E) of multi-compartment smoke control duct sections, as one of the fire resistance performance characteristics, shall be made on the basis of

- a) leakage through the duct section at ambient and after 15 min from the start of the fire test,
- b) the ability of the duct section to maintain its cross-section when subjected to the fire test,
- c) the assessment of collapse of the duct within the furnace, to confirm mechanical stability,
- d) cracks or openings in excess of given dimensions and ignition of a cotton pad and sustained flaming on the non-exposed side at the perimeter of the duct section junction with the wall or floor or duct (the penetration), and
- e) the suitability for use of the duct section at an under-pressure, measured at ambient.

When insulation characteristics are proven for multi-compartment fire resisting control duct sections, this shall be classified and declared, together with integrity.

A smoke leakage performance requirement is described in EN 13501-4 to allow the (S) classification, and this shall be applied, if the duct section is intended for the end uses where this performance is required (measured continuously after 15 min from the start of the fire test).

4.3.2 Fire resistance classification and designation

Having achieved the performance criteria in [4.3.1](#), the multi compartment smoke control duct section shall be classified and designated in accordance with EN 13501-4.

The following shall be declared for each multi-compartment smoke control duct section:

- a) integrity class “E”, integrity and insulation class “EI” (in accordance to EN 13501-4);
- b) the additions of the indication(s) of suitability for vertical and/or horizontal use, together with mounting in a floor or in a wall or both, respectively as v_e or h_o ;
- c) the addition of the symbol “S” indicates the satisfaction of an extra restriction on leakage;
- d) the addition of “500”, “1 000” or “1 500” indicates the suitability of use up to these under-pressures.

EXAMPLE EI 60 ($v_e h_o$) S 500.

If the multi-compartment smoke control duct section requirements defined in this clause are satisfied, this shall be deemed to satisfy also the corresponding single compartment smoke control duct section requirements in [4.4.1](#).

4.4 Fire resistance performance criteria: Single compartment smoke control duct sections

4.4.1 Integrity, leakage

The assessment of integrity (E) of a single compartment smoke control duct section, as one of the fire resistance performance characteristics, shall be made on the basis of

- a) leakage through the duct section at ambient and after 15 min from the start of the elevated temperature test,
- b) the ability of the duct section to maintain its cross-section when subjected to the elevated temperature test (i.e. to 600 °C),
- c) the assessment of collapse of the duct within the furnace, to confirm mechanical stability, and
- d) the suitability for use of the duct section at an under-pressure, measured at ambient.

A smoke leakage performance requirement is described in EN 13501-4 to allow the (S) classification, and this shall be applied, if the duct section is intended for the end uses where this performance is required.

4.4.2 Fire resistance classification and designation

Having achieved the performance criteria in [4.4.1](#), the single compartment smoke control duct section shall be classified and designated in accordance with EN 13501-4.

The following shall be declared for each single compartment smoke control duct section:

- a) integrity class “E₆₀₀”, (in accordance to EN 13501-4);
- b) The additions of the indication(s) of suitability for vertical and/or horizontal use, respectively: as v_e , or h_o ;
- c) The addition of the symbol “S” indicates the satisfaction of an extra restriction on leakage;

d) The addition of “500”, “1 000” or “1 500” indicates the suitability of use up to these under-pressures.

EXAMPLE E₆₀₀ 60 (v_e, h_o) S 1 500.

5 Test methods

5.1 Ambient leakage tests

The openings in the duct inside the furnace shall be sealed and the test method shall be in accordance with EN 1366-8 or EN 1366-9.

5.2 Fire resistance tests

5.2.1 General

In addition to other requirements in this document, the smoke control duct section shall be subjected to a furnace-based fire resistance test. The purpose of the test is to evaluate the ability of a smoke control duct section to prevent fire and smoke spreading from one fire compartment to another through the ductwork system which may penetrate fire separating walls and floors.

In addition, the test assesses the tightness of the ductwork while hot gases are drawn through the extraction system, ensuring that only small quantities of clean air could be sucked into the duct from areas not affected by a fire, and demonstrating low leakage out in positive pressure situations.

Single compartment smoke control duct sections will be subjected to an elevated temperature test matching the standard time temperature heating curve but levelling out to a flat maximum of 600 °C. Multi-compartment smoke control duct sections will be subjected to a fire test to the standard time temperature test curve.

Hot gases from inside the furnace are drawn through the smoke control duct section to the outside. The provision of a perforated plate allows the smoke control duct section outside the furnace to be subjected to pressure differential of 500 Pa. The leakage of the smoke control duct section outside the furnace is recorded. The leakage rate of duct sections requiring an (S) classification shall be measured both at ambient temperature and during the fire test.

Temperature and integrity measurements shall be carried out in various parts of the test construction during the test. Observations on the duct hangers and the penetration seal will be made to confirm maintenance of stability and the maximum allowable reduction in cross-section.

5.2.2 Smoke control duct section: integrity and insulation

5.2.2.1 Multi compartment smoke control duct section

Equipment, method and section size as fully described in EN 1366-8, shall be subjected to the fire resistance test. Sections shall be fire tested in the plane of proposed installation, noting the direct field of application of fire test results.

5.2.2.2 Single compartment smoke control duct section

Equipment, method and section size as fully described in EN 1366-9, shall be subjected to the fire resistance test. Sections shall be fire tested in the plane of proposed installation, noting the direct field of application of fire test results. An insulation classification is not available.

5.2.3 Leakage rated smoke control duct section

5.2.3.1 Multi compartment smoke control duct section

Equipment, method and section size as fully described in EN 1366-8, shall be subjected to the fire resistance test. Sections shall be fire tested in the plane of proposed installation, noting the direct field of application of fire test results.

5.2.3.2 Single compartment smoke control duct section

Equipment, method and section size as fully described in EN 1366-9 shall be subjected to the fire resistance test. Sections shall be fire tested in the plane of proposed installation, noting the direct field of application of fire test results.

6 Marking and documentation

Each smoke control duct section shall be marked as follows:

- the name or identifying mark of the manufacturer;
- the model/type;
- the number of this document and the year of its publication (i.e. ISO 21927-7:2017), followed by the generic name of the product “Smoke Control Duct Section”;
- the classification for resistance to fire and other related information according to EN 13501-4;
- if the smoke control duct section has an (S) classification (EN 13501-4), the words “leakage rated” shall be added;
- the date of manufacture (month and year).

7 Product, installation and maintenance information (documentation)

7.1 Product specification

The manufacturer shall provide and retain a detailed description of the product including all the relevant components. This shall include a description of the materials used (e.g. densities, thickness) in the construction of the smoke control duct.

Full details of the hanging system and any protection used shall be described.

It shall include details of the supporting construction (wall/floor, etc.) and the method of installation, including the penetration sealing product and fixing details.

Full details and specifications of any components used shall be described.

7.2 Installation information

The manufacturer shall provide appropriate installation details that shall include at least information for

- a) fixing and installation: hangers and positions, penetration seals to be used, and
- b) health and safety information to allow safe installation.

7.3 Maintenance information

The manufacturer shall provide appropriate maintenance information for the smoke control duct section that shall include at least

- a) inspection and maintenance procedures,

Regular testing/inspection should be undertaken to meet regulatory requirements, or at intervals not exceeding 12 months. A comprehensive example of the above procedure is given in [Annex A](#).

- b) the recommended frequency of operational checks, and
- c) recommended checks to establish the effects of corrosion.

Annex A (informative)

Example of inspection and maintenance procedure

After installation, when the system is running, it is recommended that the following is carried out and recorded. An example of the inspection procedure is shown in [Table A.1](#). These inspections should be undertaken at the time intervals stated in the manufacturer's maintenance information (refer to [Clause 7](#)), but at least once per year.

This is a guide to a minimum level. There may be regulatory requirements that require more frequent checking and maintenance and these shall be followed where required.

Table A.1 — Example of inspection record

Duct section reference	
Date of inspection	
Check ducting for damage	
Check connections between duct sections and ancillary components	
Check penetration seals at compartment boundaries	
Check duct cleanliness and clean where necessary	
Check the condition of seals, rectify and report where necessary	
Confirm that the duct fulfils its function as part of the smoke control system	
A smoke control duct section is inherently part of a smoke control system. As this is the case, the whole system should be checked as governed by the operation and maintenance requirements for the system.	

Bibliography

- [1] ISO 834-1, *Fire-resistance tests — Elements of building construction — Part 1: General requirements*
- [2] ISO 1101, *Geometrical Product Specifications (GPS) — Geometrical tolerancing — Tolerances of form, orientation, location and run-out*
- [3] ISO 6944-1, *Fire containment — Elements of building construction — Part 1: Ventilation ducts*
- [4] ISO 8015, *Geometrical product specifications (GPS) — Fundamentals — Concepts, principles and rules*
- [5] ISO 9001, *Quality management systems — Requirements*
- [6] ISO 9002, *Quality management systems — Guidelines for the application of ISO 9001:2015*
- [7] ISO 21927-2, *Smoke and heat control systems — Part 2: Specification for natural smoke and heat exhaust ventilators*
- [8] ISO 21927-8, *Smoke and heat control systems — Part 8: Smoke control dampers*
- [9] EN 13501-3, *Fire classification of construction products and building elements — Part 3: Classification using data from fire resistance tests on products and elements used in building service installations: fire resisting ducts and fire dampers*
- [10] EN 15882-1, *Extended application of results from fire resistance tests for service installations — Part 1: Ducts*
- [11] EN 1366-10, *Fire resistance tests for service installations — Part 10: Smoke control dampers*

British Standards Institution (BSI)

BSI is the national body responsible for preparing British Standards and other standards-related publications, information and services.

BSI is incorporated by Royal Charter. British Standards and other standardization products are published by BSI Standards Limited.

About us

We bring together business, industry, government, consumers, innovators and others to shape their combined experience and expertise into standards-based solutions.

The knowledge embodied in our standards has been carefully assembled in a dependable format and refined through our open consultation process. Organizations of all sizes and across all sectors choose standards to help them achieve their goals.

Information on standards

We can provide you with the knowledge that your organization needs to succeed. Find out more about British Standards by visiting our website at bsigroup.com/standards or contacting our Customer Services team or Knowledge Centre.

Buying standards

You can buy and download PDF versions of BSI publications, including British and adopted European and international standards, through our website at bsigroup.com/shop, where hard copies can also be purchased.

If you need international and foreign standards from other Standards Development Organizations, hard copies can be ordered from our Customer Services team.

Copyright in BSI publications

All the content in BSI publications, including British Standards, is the property of and copyrighted by BSI or some person or entity that owns copyright in the information used (such as the international standardization bodies) and has formally licensed such information to BSI for commercial publication and use.

Save for the provisions below, you may not transfer, share or disseminate any portion of the standard to any other person. You may not adapt, distribute, commercially exploit, or publicly display the standard or any portion thereof in any manner whatsoever without BSI's prior written consent.

Storing and using standards

Standards purchased in soft copy format:

- A British Standard purchased in soft copy format is licensed to a sole named user for personal or internal company use only.
- The standard may be stored on more than 1 device provided that it is accessible by the sole named user only and that only 1 copy is accessed at any one time.
- A single paper copy may be printed for personal or internal company use only.

Standards purchased in hard copy format:

- A British Standard purchased in hard copy format is for personal or internal company use only.
- It may not be further reproduced – in any format – to create an additional copy. This includes scanning of the document.

If you need more than 1 copy of the document, or if you wish to share the document on an internal network, you can save money by choosing a subscription product (see 'Subscriptions').

Reproducing extracts

For permission to reproduce content from BSI publications contact the BSI Copyright & Licensing team.

Subscriptions

Our range of subscription services are designed to make using standards easier for you. For further information on our subscription products go to bsigroup.com/subscriptions.

With **British Standards Online (BSOL)** you'll have instant access to over 55,000 British and adopted European and international standards from your desktop. It's available 24/7 and is refreshed daily so you'll always be up to date.

You can keep in touch with standards developments and receive substantial discounts on the purchase price of standards, both in single copy and subscription format, by becoming a **BSI Subscribing Member**.

PLUS is an updating service exclusive to BSI Subscribing Members. You will automatically receive the latest hard copy of your standards when they're revised or replaced.

To find out more about becoming a BSI Subscribing Member and the benefits of membership, please visit bsigroup.com/shop.

With a **Multi-User Network Licence (MUNL)** you are able to host standards publications on your intranet. Licences can cover as few or as many users as you wish. With updates supplied as soon as they're available, you can be sure your documentation is current. For further information, email subscriptions@bsigroup.com.

Revisions

Our British Standards and other publications are updated by amendment or revision.

We continually improve the quality of our products and services to benefit your business. If you find an inaccuracy or ambiguity within a British Standard or other BSI publication please inform the Knowledge Centre.

Useful Contacts

Customer Services

Tel: +44 345 086 9001

Email (orders): orders@bsigroup.com

Email (enquiries): cservices@bsigroup.com

Subscriptions

Tel: +44 345 086 9001

Email: subscriptions@bsigroup.com

Knowledge Centre

Tel: +44 20 8996 7004

Email: knowledgecentre@bsigroup.com

Copyright & Licensing

Tel: +44 20 8996 7070

Email: copyright@bsigroup.com

BSI Group Headquarters

389 Chiswick High Road London W4 4AL UK