

BS ISO 21076:2016



BSI Standards Publication

**Space data and information
transfer systems — Space
communications cross support
— Architecture requirements
document**

National foreword

This British Standard is the UK implementation of ISO 21076:2016.

The UK participation in its preparation was entrusted to Technical Committee ACE/68, Space systems and operations.

A list of organizations represented on this committee can be obtained on request to its secretary.

This publication does not purport to include all the necessary provisions of a contract. Users are responsible for its correct application.

© The British Standards Institution 2016.
Published by BSI Standards Limited 2016

ISBN 978 0 580 92097 4

ICS 49.140

Compliance with a British Standard cannot confer immunity from legal obligations.

This British Standard was published under the authority of the Standards Policy and Strategy Committee on 31 August 2016.

Amendments/corrigenda issued since publication

Date	Text affected
------	---------------

INTERNATIONAL
STANDARD

BS ISO 21076:2016

ISO
21076

First edition
2016-07-01

**Space data and information transfer
systems — Space communications
cross support — Architecture
requirements document**

*Données spatiales et systèmes de transfert d'information - Support
croisé des communications spatiales - Exigences d'architecture*



Reference number
ISO 21076:2016(E)

© ISO 2016



COPYRIGHT PROTECTED DOCUMENT

© ISO 2016, Published in Switzerland

All rights reserved. Unless otherwise specified, no part of this publication may be reproduced or utilized otherwise in any form or by any means, electronic or mechanical, including photocopying, or posting on the internet or an intranet, without prior written permission. Permission can be requested from either ISO at the address below or ISO's member body in the country of the requester.

ISO copyright office
Ch. de Blandonnet 8 • CP 401
CH-1214 Vernier, Geneva, Switzerland
Tel. +41 22 749 01 11
Fax +41 22 749 09 47
copyright@iso.org
www.iso.org

Foreword

ISO (the International Organization for Standardization) is a worldwide federation of national standards bodies (ISO member bodies). The work of preparing International Standards is normally carried out through ISO technical committees. Each member body interested in a subject for which a technical committee has been established has the right to be represented on that committee. International organizations, governmental and non-governmental, in liaison with ISO, also take part in the work. ISO collaborates closely with the International Electrotechnical Commission (IEC) on all matters of electrotechnical standardization.

The procedures used to develop this document and those intended for its further maintenance are described in the ISO/IEC Directives, Part 1. In particular the different approval criteria needed for the different types of ISO documents should be noted. This document was drafted in accordance with the editorial rules of the ISO/IEC Directives, Part 2. www.iso.org/directives

Attention is drawn to the possibility that some of the elements of this document may be the subject of patent rights. ISO shall not be held responsible for identifying any or all such patent rights. Details of any patent rights identified during the development of the document will be in the Introduction and/or on the ISO list of patent declarations received. www.iso.org/patents

Any trade name used in this document is information given for the convenience of users and does not constitute an endorsement.

For an explanation on the meaning of ISO specific terms and expressions related to conformity assessment, as well as information about ISO's adherence to the WTO principles in the Technical Barriers to Trade (TBT) see the following URL: Foreword - Supplementary information

ISO 21076 was prepared by the Consultative Committee for Space Data Systems (CCSDS) (as CCSDS 901.1-M-1, May 2015) and was adopted (without modifications except those stated in clause 2 of this International Standard) by Technical Committee ISO/TC 20, *Aircraft and space vehicles*, Subcommittee SC 13, *Space data and information transfer systems*.

STATEMENT OF INTENT

The Consultative Committee for Space Data Systems (CCSDS) is an organization officially established by the management of its members. The Committee meets periodically to address data systems problems that are common to all participants, and to formulate sound technical solutions to these problems. Inasmuch as participation in the CCSDS is completely voluntary, the results of Committee actions are termed **Recommendations** and are not in themselves considered binding on any Agency.

CCSDS Recommendations take two forms: **Recommended Standards** that are prescriptive and are the formal vehicles by which CCSDS Agencies create the standards that specify how elements of their space mission support infrastructure shall operate and interoperate with others; and **Recommended Practices** that are more descriptive in nature and are intended to provide general guidance about how to approach a particular problem associated with space mission support. This **Recommended Practice** is issued by, and represents the consensus of, the CCSDS members. Endorsement of this **Recommended Practice** is entirely voluntary and does not imply a commitment by any Agency or organization to implement its recommendations in a prescriptive sense.

No later than five years from its date of issuance, this **Recommended Practice** will be reviewed by the CCSDS to determine whether it should: (1) remain in effect without change; (2) be changed to reflect the impact of new technologies, new requirements, or new directions; or (3) be retired or canceled.

In those instances when a new version of a **Recommended Practice** is issued, existing CCSDS-related member Practices and implementations are not negated or deemed to be non-CCSDS compatible. It is the responsibility of each member to determine when such Practices or implementations are to be modified. Each member is, however, strongly encouraged to direct planning for its new Practices and implementations towards the later version of the Recommended Practice.

CCSDS RECOMMENDED PRACTICE FOR SPACE COMMUNICATIONS CROSS SUPPORT—
ARCHITECTURE REQUIREMENTS DOCUMENT

FOREWORD

Through the process of normal evolution, it is expected that expansion, deletion, or modification of this document may occur. This Recommended Practice is therefore subject to CCSDS document management and change control procedures, which are defined in the *Organization and Processes for the Consultative Committee for Space Data Systems* (CCSDS A02.1-Y-4). Current versions of CCSDS documents are maintained at the CCSDS Web site:

<http://www.ccsds.org/>

Questions relating to the contents or status of this document should be sent to the CCSDS Secretariat at the e-mail address indicated on page i.

At time of publication, the active Member and Observer Agencies of the CCSDS were:

Member Agencies

- Agenzia Spaziale Italiana (ASI)/Italy.
- Canadian Space Agency (CSA)/Canada.
- Centre National d'Etudes Spatiales (CNES)/France.
- China National Space Administration (CNSA)/People's Republic of China.
- Deutsches Zentrum für Luft- und Raumfahrt (DLR)/Germany.
- European Space Agency (ESA)/Europe.
- Federal Space Agency (FSA)/Russian Federation.
- Instituto Nacional de Pesquisas Espaciais (INPE)/Brazil.
- Japan Aerospace Exploration Agency (JAXA)/Japan.
- National Aeronautics and Space Administration (NASA)/USA.
- UK Space Agency/United Kingdom.

Observer Agencies

- Austrian Space Agency (ASA)/Austria.
- Belgian Federal Science Policy Office (BFSP0)/Belgium.
- Central Research Institute of Machine Building (TsNIIMash)/Russian Federation.
- China Satellite Launch and Tracking Control General, Beijing Institute of Tracking and Telecommunications Technology (CLTC/BITTT)/China.
- Chinese Academy of Sciences (CAS)/China.
- Chinese Academy of Space Technology (CAST)/China.
- Commonwealth Scientific and Industrial Research Organization (CSIRO)/Australia.
- Danish National Space Center (DNSC)/Denmark.
- Departamento de Ciência e Tecnologia Aeroespacial (DCTA)/Brazil.
- Electronics and Telecommunications Research Institute (ETRI)/Korea.
- European Organization for the Exploitation of Meteorological Satellites (EUMETSAT)/Europe.
- European Telecommunications Satellite Organization (EUTELSAT)/Europe.
- Geo-Informatics and Space Technology Development Agency (GISTDA)/Thailand.
- Hellenic National Space Committee (HNSC)/Greece.
- Indian Space Research Organization (ISRO)/India.
- Institute of Space Research (IKI)/Russian Federation.
- KFKI Research Institute for Particle & Nuclear Physics (KFKI)/Hungary.
- Korea Aerospace Research Institute (KARI)/Korea.
- Ministry of Communications (MOC)/Israel.
- National Institute of Information and Communications Technology (NICT)/Japan.
- National Oceanic and Atmospheric Administration (NOAA)/USA.
- National Space Agency of the Republic of Kazakhstan (NSARK)/Kazakhstan.
- National Space Organization (NSPO)/Chinese Taipei.
- Naval Center for Space Technology (NCST)/USA.
- Scientific and Technological Research Council of Turkey (TUBITAK)/Turkey.
- South African National Space Agency (SANSA)/Republic of South Africa.
- Space and Upper Atmosphere Research Commission (SUPARCO)/Pakistan.
- Swedish Space Corporation (SSC)/Sweden.
- Swiss Space Office (SSO)/Switzerland.
- United States Geological Survey (USGS)/USA.

CCSDS RECOMMENDED PRACTICE FOR SPACE COMMUNICATIONS CROSS SUPPORT—
ARCHITECTURE REQUIREMENTS DOCUMENT

DOCUMENT CONTROL

Document	Title	Date	Status
CCSDS 901.1-M-1	Space Communications Cross Support—Architecture Requirements Document, Recommended Practice, Issue 1	May 2015	Original issue

CONTENTS

<u>Section</u>	<u>Page</u>
1 INTRODUCTION	1-1
1.1 PURPOSE.....	1-1
1.2 SCOPE.....	1-1
1.3 APPLICABILITY.....	1-3
1.4 RATIONALE.....	1-4
1.5 DOCUMENT STRUCTURE.....	1-4
1.6 DEFINITIONS AND CONVENTIONS.....	1-5
1.7 REFERENCES.....	1-12
2 OVERVIEW	2-1
2.1 BACKGROUND.....	2-1
2.2 ROLE OF THIS ARCHITECTURE REQUIREMENTS DOCUMENT.....	2-1
2.3 STRUCTURE OF THE ARD: FOUR VIEWS OF SYSTEM ARCHITECTURE.....	2-3
2.4 RELATIONSHIPS BETWEEN SCCS AND OTHER CCSDS DOCUMENTS.....	2-5
2.5 CROSS SUPPORT SERVICE SYSTEM ELEMENTS.....	2-6
2.6 BASIC SYSTEM-ELEMENT CONFIGURATIONS.....	2-9
2.7 NETWORK TERMINOLOGY.....	2-11
2.8 PRACTICAL LIMITS ON PROTOCOL CHOICES.....	2-14
2.9 HOW TO USE THIS DOCUMENT.....	2-15
3 CROSS SUPPORT OVERVIEW OF ABA AND SSI TECHNICAL ARCHITECTURE—CROSS SUPPORT BUILDING BLOCKS	3-1
3.1 OVERVIEW.....	3-1
3.2 BUILDING-BLOCK FUNCTIONS.....	3-2
4 SERVICE VIEW	4-1
4.1 OVERVIEW.....	4-1
4.2 ABA SERVICES.....	4-2
4.3 SSI SERVICES.....	4-7
4.4 SECURITY REQUIREMENTS FOR SERVICES.....	4-12
5 PHYSICAL VIEW	5-1
5.1 OVERVIEW.....	5-1
5.2 ABA-SPECIFIC ELEMENTS.....	5-2
5.3 SSI PHYSICAL ELEMENTS.....	5-13
5.4 SECURITY REQUIREMENTS FOR PHYSICAL ELEMENTS.....	5-25

CCSDS RECOMMENDED PRACTICE FOR SPACE COMMUNICATIONS CROSS SUPPORT—
 ARCHITECTURE REQUIREMENTS DOCUMENT

CONTENTS (continued)

<u>Section</u>	<u>Page</u>
6 COMMUNICATIONS VIEW	6-1
6.1 OVERVIEW	6-1
6.2 PROTOCOL BUILDING BLOCKS	6-6
7 END-TO-END DEPLOYMENT VIEW	7-1
7.1 OVERVIEW	7-1
7.2 ABA END-TO-END PROTOCOL VIEWS—REQUIREMENTS	7-1
7.3 SSI END-TO-END PROTOCOL VIEWS: REQUIREMENTS.....	7-3
7.4 DISCUSSION—SECURITY REQUIREMENTS FOR END-TO-END DEPLOYMENTS	7-5
ANNEX A SECURITY AND SANA CONSIDERATIONS (INFORMATIVE)	A-1
ANNEX B GLOSSARY (INFORMATIVE)	B-1
ANNEX C ABBREVIATIONS (INFORMATIVE)	C-1
ANNEX D INFORMATIVE REFERENCES (INFORMATIVE)	D-1

Figure

1-1 Graphical Conventions	1-10
2-1 Roles of the SCCS Architecture Documents	2-2
2-2 Basic ABA Configuration.....	2-10
2-3 SSI Core Configuration	2-11
2-4 The SSI	2-13
3-1 Generic ABA End-to-End Deployment.....	3-1
3-2 Generic SSI End-to-End Deployment	3-2
4-1 ABA Service Interfaces	4-2
4-2 SSI End-to-End Run-Time Service Interfaces.....	4-7
4-3 SSI ESLT Service Interfaces for Earth Routing Node	4-8
5-1 ABA Node—Generic Building Block	5-2
5-2 SSI Node—Generic Building Block.....	5-13
6-1 ABA ESLT Protocol Building Blocks.....	6-8
6-2 ABA ESLT Radiometric Processing Protocol Building Blocks.....	6-10
6-3 ABA ESLT Service Management Protocol Building Blocks.....	6-11
6-4 ABA ESLT Service Management Configuration and Execution Building Blocks....	6-12
6-5 ABA ESLT Monitor Data Protocol Building Blocks	6-13
6-6 ESLT Service Control Service-Provider Protocol Stack Building Blocks.....	6-14
6-7 ESLT Delta-DOR Service-Provider Protocol Stack Building Blocks.....	6-15
6-8 ABA ESLT Forward-File Protocol Building Blocks.....	6-16
6-9 ABA ESLT Return File Protocol Building Blocks.....	6-17

CONTENTS (continued)

<u>Figure</u>	<u>Page</u>
6-10 ABA Earth User Forward Protocol Building Blocks	6-19
6-11 ABA Earth User Node Return Protocol Building Blocks	6-20
6-12 ABA Earth User Radiometric, Monitor and Control Protocol Building Blocks	6-22
6-13 ABA Space User Forward Protocol Building Blocks.....	6-25
6-14 ABA Space User Return Protocol Building Blocks	6-26
6-15 ABA Space User Ranging Protocol Building Blocks.....	6-27
6-16 ABA Space User Delta-DOR Protocol Building Blocks.....	6-28
6-17 Secure ABA Earth User F-Frame and Forward-File Protocol Building Blocks	6-28
6-18 Secure ABA Space User F-Frame and Forward-File Protocol Building Blocks.....	6-29
6-19 SSI ESLT and User DTN Protocol Building Blocks.....	6-32
6-20 SSI ESLT and User DTN Forward-File Building Blocks	6-33
6-21 SSI ESLT and User Service Management Building Blocks.....	6-35
6-22 SSI Space User and Routing Node DTN Protocol Building Blocks	6-36
6-23 SSI ESLT and Space Routing DTN Network Management Building Blocks.....	6-37
6-24 SSI Earth Routing Node Forward Building Blocks.....	6-38
6-25 SSI Earth Routing Node Return Building Block.....	6-39
6-26 SSI Earth User Node DTN Forward Building Blocks.....	6-40
6-27 SSI Space User DTN Forward-File Building Blocks	6-42
6-28 SSI Space User and Routing Node Local LAN Building Blocks.....	6-42
6-29 SSI Secure Forward-File Building Blocks	6-43
6-30 SSI Secure Space User and Space Routing Node Building Blocks.....	6-45
6-31 SSI Last-Hop/First-Hop Delivery Agent Building Blocks.....	6-47
6-32 SSI User Last-Hop/First-Hop Transfer File Building Block.....	6-50
7-1 ABA End-to-End Forward: ABA Agency Supporting ABA Agency	7-2
7-2 SSI End-to-End Forward: SSI Agency Supporting SSI Agency	7-3
7-3 ABA Secure End-to-End Forward: ABA Agency Supporting ABA Agency	7-6
7-4 SSI Secure End-to-End Forward: SSI Agency Supporting SSI Agency	7-6

Table

2-1 Cross Support Service Elements and Nominal Locations	2-7
2-2 User Elements and Nominal Locations	2-8
2-3 Examples of Provider Cross Support Service Systems and Related Elements	2-9
2-4 Examples of User Cross Support Service Systems and Related User Elements	2-9
2-5 Example BDPs for Different Earth and Space Applications	2-15
2-6 Examples of Mission Application-Specific Views.....	2-17
5-1 ABA CSSE Node Type, Interfaces, and Functions	5-3
5-2 ABA UE Node Types, Interfaces, and Functions.....	5-7
5-3 SSI CSSE Node Types, Interfaces, and Functions	5-14
5-4 SSI UE Node Types, Interfaces, and Functions	5-21

CCSDS RECOMMENDED PRACTICE FOR SPACE COMMUNICATIONS CROSS SUPPORT—
ARCHITECTURE REQUIREMENTS DOCUMENT

CONTENTS (continued)

<u>Table</u>	<u>Page</u>
6-1 Referenced Communications Protocols.....	6-2
6-2 Referenced Cross Support Protocols	6-4
6-3 Referenced Security Protocols.....	6-5
6-4 Required and Optional ABA ESLT Terrestrial Side Protocols.....	6-6
6-5 Required and Optional ABA ESLT Space Side Protocols	6-7
6-6 Required and Optional ABA Earth User Node Protocols	6-18
6-7 Required and Optional ABA Space User Node Protocols.....	6-24

1 INTRODUCTION

1.1 PURPOSE

The purpose of this Recommended Practice is to define a set of requirements for CCSDS-recommended configurations for secure Space Communications Cross Support (SCCS) architectures. This architecture is to be used as a common framework when CCSDS Agencies 1) provide and use SCCS services, and 2) develop systems that provide interoperable SCCS services. These SCCS services include both elements on the ground and elements in space. These services cover both single-hop, space Data Link Layer services (Mission Operations Center [MOC]-to-spacecraft), and Solar System Internet (SSI), multi-hop, Network Layer services that involve data routing and internetworking using multiple space assets.

NOTE – The term ‘agency’ is used in CCSDS, but users of CCSDS cross support concepts include satellite operators and service providers, and the context of the cross support is not limited to a user/provider interface with an agency.

This Space Communications Cross Support—Architecture Requirements Document (SCCS-ARD) provides normative specifications and definitions; its companion Space Communications Cross Support—Architecture Description Document (SCCS-ADD) (reference [D5]) provides the descriptive information, explanatory materials, and other graphical representations that support the understanding of these requirements.

1.2 SCOPE

This document describes SCCS architecture in terms of the following:

- definitions of all key elements, on ground and in space, that are involved in space communications;
- definitions of concepts that characterize SCCS services;
- requirements on system elements and components that provide secure SCCS services;
- recommended protocol stack configurations for each element type; and
- recommended end-to-end system configurations to provide interoperable and cross-supportable space communications services.

This document does not specify:

- the details of how to implement systems that provide SCCS services;
- explicit technologies needed to implement SCCS services;
- application or mission operations protocols except for those used for data transfer;

CCSDS RECOMMENDED PRACTICE FOR SPACE COMMUNICATIONS CROSS SUPPORT—
ARCHITECTURE REQUIREMENTS DOCUMENT

- mission operations except for those involved in planning, scheduling, and executing space communications;
- spacecraft onboard cross support, except for space communication services.

This document contains references to other CCSDS technical engineering and architectural recommendations describing how systems doing space communication cross support should be engineered, deployed, organized, and operated to provide interoperable SCCS services. While this document does not specify detailed internal implementation approaches, which are a private matter, it does recommend specific protocols and protocol stacks, service interfaces, element behaviors, and end-to-end architectures.

Some of the standards that are referenced in this document, especially those relating to the SSI, are still in development. They are included here so the reader gets a clear understanding of how they fit into an overall architecture.

The protocol-related parts of this document make liberal reference to the layers defined in the Open Systems Interconnection (OSI) Basic Reference Model (reference [4]). Subsection 6.2 of the Architecture Description Document (ADD) (reference [D5]) contains a discussion of the OSI stack and the functions associated with each layer.

The technical scope of single-hop cross support is the provision of Data Link Layer (Layer 2) data communications services across the Solar System in support of space mission users, using the *interoperable infrastructure of one or more space agencies*. Services above the Data Link Layer, such as CCSDS File Delivery Protocol (CFDP), Cross-Support File Service (CXFS), or Delta-Differential One-way Range (DOR), may also be provided. All mission operations application in CCSDS-compliant, interoperable, single-hop deployments are expected to utilize these underlying space link and file communications layers.

The technical scope of the SSI is the provision of internetworked (Layer 3) data communications services across the Solar System in support of space mission users, using the *confederated and interoperable infrastructure of one or more space agencies* to achieve a level of service that individual agencies would otherwise be unlikely to achieve. All mission operations application in CCSDS-compliant, interoperable, SSI deployments are expected to utilize these underlying space internetworking communications layers.

The temporal scope of this document covers current, single-hop, secure interoperable cross support installations, future deployments of an interoperable and evolving space networking infrastructure, and the transition strategies to evolve from current deployments to a future SSI state. Included in this discussion are mission-driven considerations, such as use of hybrid science/routing missions, as well as identification of optional configurations that are considered acceptable because they are in line with the transition strategies defined in this document.

Any agency that wishes to participate as a peer in the SSI should implement interoperable services and interfaces at least up to the Network Layer, along with related support services, as described in this document and specified in the relevant CCSDS and Internet standards.

Agencies that are not yet ready to adopt the SSI themselves, but that wish to offer compliant ground station cross support services that can support SSI services, may also take advantage of this document for guidance on developing Data Link Layer services that will both meet their immediate needs and also interoperate with SSI-enabled missions.

1.3 APPLICABILITY

1.3.1 APPLICABILITY OF THIS RECOMMENDED PRACTICE

This Recommended Practice provides a set of reference architecture requirements for the development of CCSDS compatible agency systems for space communications. This Recommended Practice is applicable to all space communication systems that are involved in cross support.

The SCCS systems that are addressed in this Recommended Practice explicitly include ground stations and related systems that provide cross support services, user mission control and mission operations ground systems, and a variety of spacecraft systems. In all cases the applicability is to both single space link (ABA) and internetworked (SSI) systems. The term ‘spacecraft systems’ includes free-flying spacecraft, landers, rovers, and even balloons and other ‘platforms’ that are users of space communication services. It also includes spacecraft that are themselves providers of space communication services.

1.3.2 LIMIT OF APPLICABILITY

This Recommended Practice is not a design for real SCCS systems that may be implemented for communication with existing or future missions. It provides detailed, but broadly stated, requirements that may be tailored or adapted for use in constructing such systems.

Future CCSDS requirements (e.g., service interfaces, protocols, or data formats) that are planned, but still under development, are included for completeness so that the directions of CCSDS are clear; these are marked ‘[Future]’ to avoid ambiguity. Any requirements that are considered optional are marked ‘[Opt]’. The [Opt] requirements are things like security, which may or may not be implemented by any given system. All other core standards, those that are expected to be used by the bulk of missions and implemented by the bulk of service providers, are defined as mandatory, with ‘shall’ rather than ‘should’ language. Any specific system deployment may treat these as ‘shall’ if they are required for that use.

Any requirements marked ‘[Future]’ should not be relied upon in the design of current real SCCS systems. This Recommended Practice will be updated periodically. When updates of this document are published, any requirements now marked ‘[Future]’ whose conditions are met will be reviewed and evaluated for inclusion as full requirements. Many of these future specifications are completely applicable to either ABA or SSI deployments.

CCSDS RECOMMENDED PRACTICE FOR SPACE COMMUNICATIONS CROSS SUPPORT—
ARCHITECTURE REQUIREMENTS DOCUMENT

1.4 RATIONALE

CCSDS has developed a body of space communications recommendations that specify protocols and related services for specific types of functionality that are usually defined at a single layer of the OSI stack, or define how to format and exchange a specific type of information. In order to build end-to-end space communications systems that will interoperate, systems designers need to understand how to select, configure, and deploy different kinds of system elements that implement a complete stack of protocols in each element and how these are assembled to deliver end-to-end services. Single-hop communications configurations often require cross support, where one space agency develops the spacecraft and the corresponding MOC, and another agency provides the ground communications assets. This is the typical cross support configuration used today. Multi-hop communications configurations may require that space assets developed by one agency offer cross support to space elements developed by another agency, with both being supported by ground communications assets from yet another agency.

Since cross support among agencies has become the norm, and since future agency collaborative missions require elements developed by different agencies, at different times, to interoperate as a network, agreed-upon interoperable standards and architectures must be adopted in an end-to-end sense. As the only international body that defines standards to link space communication service providers with space missions, CCSDS is defining this recommended standard architecture for SCCS services, so that interoperable cross support between agencies can be defined and operated more efficiently and effectively for single-hop and multi-hop mission configurations.

Similar to existing ABA architectures, it is fundamental to the SSI concept that all full participants in the confederation must expose standard and agreed-upon cross support services at the Network Layer of the OSI communications stack, while observing common network management strategies and governance mechanisms. Agencies that provide only single-hop Data Link Layer services may still participate in the SSI if they provide compliant services at that layer.

1.5 DOCUMENT STRUCTURE

This document consists of several sections plus annexes.

- Section 1 presents the purpose, scope, and rationale of this document and lists the definitions, conventions, and references used throughout the document.
- Section 2 provides context and an overview of the SCCS architecture.
- Section 3 provides a brief overview of ABA and SSI technical architecture and some guidance on how to use the document.
- Section 4 defines top-level service requirements of ABA and SSI configurations from user and provider perspectives.

- Section 5 defines physical requirements of spacecraft and ground system nodes that are used to create deployed ABA and SSI configurations, their allocated functions, and behavior.
- Section 6 defines communications requirements and protocol ‘stacks’ for the ABA and SSI node types.
- Section 7 defines end-to-end deployment requirements for representative examples of space communication configurations.
- Annexes provide a brief reference to security and Space Assigned Numbers Authority (SANA) information, a normative glossary, an acronym list, and a list of informative references.

Each of sections 4 through 7 includes a brief descriptive introduction and normative subsections that define the required elements, attributes, and behaviors for both ABA and SSI deployments. The ADD (reference [D5]) contains an extended set of descriptive materials that provide explanations and examples.

1.6 DEFINITIONS AND CONVENTIONS

1.6.1 TERMS

For the purposes of this document, the following normative definitions apply. Many of these terms are derived from other sources. Primary sources of definitions are references [1], [2], [4], [5], [6], [D6], [D7], and [D8].

NOTE – Many other terms that pertain to specific items are defined in the appropriate sections. A glossary with additional definitions can be found in annex B, and a list of acronyms can be found in annex C.

ABA: A ‘single-hop’ space communications configuration that involves only a single direct to/from Earth space link. Term derives from the notion of an Agency ‘A’ using the ground station of an Agency ‘B’ to communicate between its MOC and its spacecraft, hence ABA.

ABCBA: A multi-hop space communications configuration that involves multiple space and ground elements and one or more direct to/from Earth space links or space-space links. ABCBA configurations nominally include elements from three or more agencies.

Application Layer: OSI Layer 7 contains all those functions that imply communication between open systems that are not already performed by the lower layers.

building block: The set of nodes, with specific defined characteristics, that are used to describe end-to-end system configurations in this document.

CCSDS RECOMMENDED PRACTICE FOR SPACE COMMUNICATIONS CROSS SUPPORT—
ARCHITECTURE REQUIREMENTS DOCUMENT

CCSDS-compliant credential: One or more CCSDS baseline recommended credentials that have the minimum recommended level of security. Higher-level security credentials (to be defined in an update to reference [7]) may be employed where required.

Coding and Synchronization sublayer: CCSDS-defined sublayer (of the OSI Data Link Layer) that provides error detection and correction for the space Data Link Layer protocols and deals with noisy, low signal-to-noise ratio, space link physical channel characteristics.

credential: A physical/tangible object, a piece of knowledge, or a facet of a person's physical being, that enables an individual to have access to a given physical facility or computer-based information system.

cross support: An agreement between two or more organizations to exploit the technical capability of interoperability for mutual advantage, such as one organization offering support services to another in order to enhance or enable some aspect of a space mission.

cross support service: A function provided by one space agency to support operations of a space mission of another space agency.

cross support service element, CSSE: A physical element involved in providing one or more cross support services (including functions for managing services).

cross support service system, CSSS: A set of CSSEs or user elements that are managed by a single authority with a single set of management policies. These may be user or provider systems.

Cross Support Transfer Service, CSTS: A family of cross support services, based upon a common framework derived from space link extension, that provides reliable, access-controlled transfer of spaceflight mission-related data between ground CSSEs and user elements. Each type of CSTS is qualified by the kind of data it transfers (e.g., telemetry frames, tracking data, monitor data).

data delivery services: The generic term for the CSTS and space link extension services used to deliver data between an Earth-Space Link Terminal (ESLT) and the ground user elements that use it.

Data Link Layer: The OSI Layer (Layer 2, often referred to as 'link layer') that provides functional and procedural means for the establishment, maintenance, and release of data link connections among Network Layer entities (where they are used) and for the transfer of data link service data units.

Earth User Node: A physical element, located on the ground, that uses a cross support service provided by a CSSS.

element management, EM: A set of functions that manage elements and interact with PM for purposes of ascertaining element resource availability, configuration and execution of element resources, and reporting status of those resources.

forward data: Data sent from a ground element to a space element.

forwarding: The act of transferring data from its source towards its destination, which may be in space or on the ground.

functional resource: The functions or capabilities that are provided by physical resources (e.g., transmitters and receivers) of a CSSE, but not those physical resources themselves. A functional resource is a logical construct not necessarily linked to any single system component.

interface binding signature: A ‘signature’ that results from a service user and service provider implementing the proper stack of interface protocols in order to bind to service elements. This signature may involve Transmission Control Protocol/Internet Protocol (TCP/IP), Hypertext Transfer Protocol (HTTP), or some set of CCSDS space-communication protocols.

internetwork: A ‘network of networks’ (often shortened to *internet*), where two or more distinct computer networks are connected together using routing devices that allow traffic to flow back and forth between the networks.

internetworking: Practice of connecting two or more distinct computer networks or network segments together to form an internetwork, using devices which operate at OSI Layer 3 (Network Layer) to connect them together to allow traffic to flow back and forth between them.

interoperability: A property of protocols or systems whereby elements adopt a commonly defined and implemented set of protocols, data, and behaviors.

logical link: A link that shows a relationship between various types of logical objects (e.g., functions, protocols, or organizations). It may be considered separately from any particular implementation or deployment and has no physical manifestation except as part of a model.

network: One or more computers or other processing elements that are owned by a single organization, communicating using a single OSI Layer 3 protocol and sharing a single Layer-2 technology.

Network Layer: OSI Layer 3, which provides the means to establish, maintain, and terminate network connections between open systems and provides transport entities independence from routing and relay considerations.

node: A space data system physical entity operating in a physical environment. A node is a configuration of engineering objects forming a single unit for the purpose of location in space, and embodying a set of processing, storage, and communication functions. A node has some well-understood, possibly rapidly moving location, and it may be composed of two or more (sub-) nodes.

physical channel: A stream of bits transferred over a space link in a single direction.

CCSDS RECOMMENDED PRACTICE FOR SPACE COMMUNICATIONS CROSS SUPPORT—
ARCHITECTURE REQUIREMENTS DOCUMENT

Physical Layer: OSI Layer 1, which provides for the transparent transmission of bit streams between data-link entities across physical connections and the mechanical, electrical, functional, and procedural means to activate, maintain, and deactivate physical connections.

protocol data unit, PDU: A unit of data which is specified in a protocol of a given layer and which consists of protocol-control information, addressing information, and possibly user data for that layer (typically defined as a Service Data Unit [SDU]).

provider system: A CSSS that provides services to a user CSSS. A provider CSSS may also be a user of other CSSS services.

provision management, PM: A set of functions of a CSSS, related to the acquisition and management of services provided by that CSSS to other CSSSes. PM interacts with the utilization management of user CSSSes to negotiate provision of services to their respective CSSSes.

Proximity link: A communications link between an element in space and another nearby element in space or on the surface of a planetary body (<1 second Round-Trip Light Time [RTL]).

relaying: A managed process for forwarding frame, packet, or physical data that involves no decision making.

return data: Data sent from a space element to a ground element.

router: A device that forwards Network Layer PDUs between computer networks, creating an Internetwork. A router is connected to two or more data links from different subnetworks and uses address information in the PDU and information in its routing table or routing policy to direct the PDU to the next subnetwork.

routing: The process of selecting paths from origins to destinations in a network.

service management, SM: 1) The set of functions exposed by PM to utilization management for the purposes of acquiring and managing the services provided by the provider CSSS to the user CSSS. These functions include planning, scheduling, and managing the configuration of space communication service functions. 2) The specification for exchanging service management information.

service provider: The role played by a physical, functional, or organizational entity that provides a cross support service for a service user. (A single entity may play the roles of service provider and service user at the same time.)

service user: The role played by a physical, functional, or organizational entity that uses a cross support service provided by a service provider. (A single entity may play the roles of service provider and service user at the same time.)

signal-to-noise ratio, SNR: A measure that compares the level of a desired signal to the level of background noise. The principal signal degradations in space communications are due to the loss of signal energy with distance, and to the thermal noise in the receiving system.

Solar System Internetwork, SSI: A loose confederation of independent space communications networks that all share a single Network-Layer protocol that allows them to interoperate and exchange Network-Layer PDUs, each often owned and administered by a different space agency.

space communications protocol: A communications protocol designed to be used over a space link or in a network that contains one or multiple space links.

space link: A communications link between a spacecraft and its associated ground system or between two spacecraft. A space link consists of one or more physical channels in one or both directions.

space link extension, SLE: A set of specific cross support services that provide reliable, access-controlled transfer of spaceflight mission-related data between ground cross support service providers and user elements. Each specific SLE service is defined separately for the kind of data it transfers (e.g., telemetry frames, telecommand, Communication Link Transmission Units [CLTUs], Operational Control Field [OCF]). CSTS is a generalization of the SLE concept.

space link interface: The interface of a CSSE that uses space link protocols.

space link layer processing: Processing at OSI Layers 1 and 2 for space communications, including any needed framing, coding, and modulation.

space routing node: A physical element located in space that provides space internetworking services.

Space User Node: A physical element located in space that uses a cross support service provided by a CSSS.

supported agency: A space agency that uses cross support services.

supporting agency: A space agency that provides cross support services.

terrestrial-link interface: The interface of a CSSE that uses terrestrial link (and networking) protocols.

Transport Layer: OSI Layer 4, which has end-to-end significance, where the ends are defined as transport entities having transport associations. The Transport Layer provides transparent transfer of data between applications and relieves them from any concern with subnetwork topologies or the detailed way in which transfer of data is achieved.

CCSDS RECOMMENDED PRACTICE FOR SPACE COMMUNICATIONS CROSS SUPPORT—
 ARCHITECTURE REQUIREMENTS DOCUMENT

user element, UE: A physical element involved in using one or more cross support services (including functions for managing services).

user system: A CSSS that uses the services of a provider CSSS. A user CSSS may also be a provider CSSS for other CSSSes.

utilization management, UM: A set of functions of a CSSS or user system, related to the acquisition and management of services provided to that CSSS or user system by other CSSSes.

virtual channel, VC: A logical subdivision of a single physical or master channel.

1.6.2 CONVENTIONS

For the purposes of this document, the graphical conventions shown in figure 1-1 are used. They are derived from the Reference Architecture for Space Data Systems (RASDS) (reference [2]).

There are several different types of objects depicted in the diagrams in this document; they may be color coded according to the key to identify their different nature and/or associated functionality.

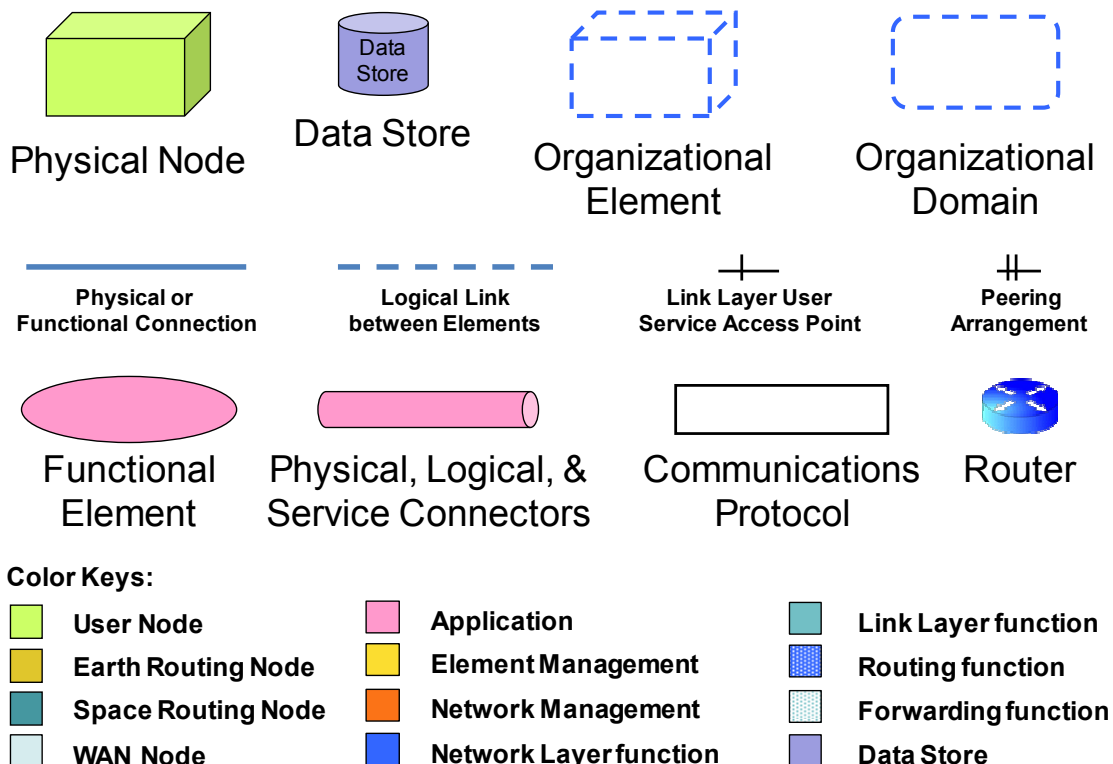

Figure 1-1: Graphical Conventions

NOTES

- 1 Physical nodes (system elements) are depicted with solid three-dimensional boxes.
- 2 Data stores are shown as a cylinder.
- 3 Organizations are depicted with dashed three-dimensional boxes. Organizational domains are depicted with rounded, dashed, two-dimensional boxes.
- 4 Physical or functional connections are depicted with solid lines.
- 5 Logical links between elements are depicted with dashed lines.
- 6 Functional elements (aside from communications protocols) are depicted with ovals.
- 7 Service connections are depicted as pipes.
- 8 Communications protocols are depicted with two-dimensional boxes.
- 9 The differences between link layer user service (ABA) and peering arrangement (SSI) are distinguished as shown, where needed.

1.6.3 NOMENCLATURE

1.6.3.1 Normative Text

The following conventions apply for the normative specifications in this document:

- a) the words 'shall' and 'must' imply a binding and verifiable specification;
- b) the word 'should' implies an optional, but desirable, specification;
- c) the word 'may' implies an optional specification;
- d) the words 'is', 'are', and 'will' imply statements of fact.

NOTE – These conventions do not imply constraints on diction in text that is clearly informative in nature.

1.6.3.2 Informative Text

In the normative sections of this document, informative text is set off from the normative specifications either in notes or under one of the following subsection headings:

- Overview;
- Background;
- Rationale;
- Discussion.

CCSDS RECOMMENDED PRACTICE FOR SPACE COMMUNICATIONS CROSS SUPPORT—
ARCHITECTURE REQUIREMENTS DOCUMENT

1.7 REFERENCES

The following documents are CCSDS, Internet, or other international standards referenced in this document. At the time of publication, the editions indicated were valid. All of the documents in this section that have CCSDS Blue or Magenta book numbers, or that have Request for Comment (RFC) or an RFC that has become a standard (STD), ISO, or other numbers are formal specifications that are valid as of the time of publication. Users of this Recommended Practice should be aware that in order to provide adequate guidance for the future, some of the documents that are referenced are still under development (CCSDS Red Books, White Books) or are otherwise in draft form, and these are so marked. There is, of course, a finite chance that some of these standards, when finalized, will not have exactly the features that are described here. A list of additional informative references is provided in annex D.

- [1] *Cross Support Reference Model—Part 1: Space Link Extension Services*. Issue 2. Recommendation for Space Data System Standards (Blue Book), CCSDS 910.4-B-2. Washington, D.C.: CCSDS, October 2005.
- [2] *Reference Architecture for Space Data Systems*. Issue 1. Recommendation for Space Data System Practices (Magenta Book), CCSDS 311.0-M-1. Washington, D.C.: CCSDS, September 2008.
- [3] *Operations Concept for a Solar System Internetwork (SSI)*. IOAG.T.RC.001.V1. Washington, DC: IOAG, 15 October 2010.
- [4] *Information Technology—Open Systems Interconnection—Basic Reference Model: The Basic Model*. 2nd ed. International Standard, ISO/IEC 7498-1:1994. Geneva: ISO, 1994.
- [5] *Solar System Internetwork (SSI) Issue Investigation and Resolution*. IOAG.T.SP.001.V1. Washington, DC: IOAG, 1 August 2010.
- [6] *Security Architecture for Space Data Systems*. Issue 1. Recommendation for Space Data System Practices (Magenta Book), CCSDS 351.0-M-1. Washington, D.C.: CCSDS, November 2012.
- [7] *CCSDS Cryptographic Algorithms*. Issue 1. Recommendation for Space Data System Standards (Blue Book), CCSDS 352.0-B-1. Washington, D.C.: CCSDS, November 2012.
- [8] *TC Synchronization and Channel Coding*. Issue 2. Recommendation for Space Data System Standards (Blue Book), CCSDS 231.0-B-2. Washington, D.C.: CCSDS, September 2010.
- [9] *AOS Space Data Link Protocol*. Issue 2. Recommendation for Space Data System Standards (Blue Book), CCSDS 732.0-B-2. Washington, D.C.: CCSDS, July 2006.

CCSDS RECOMMENDED PRACTICE FOR SPACE COMMUNICATIONS CROSS SUPPORT—
ARCHITECTURE REQUIREMENTS DOCUMENT

- [10] *TM Space Data Link Protocol*. Issue 1. Recommendation for Space Data System Standards (Blue Book), CCSDS 132.0-B-1. Washington, D.C.: CCSDS, September 2003.
- [11] *Information Technology—Open Distributed Processing—Reference Model: Architecture*. International Standard, ISO/IEC 10746-3:1996. Geneva: ISO, 1996.
- [12] K. Scott and S. Burleigh. *Bundle Protocol Specification*. RFC 5050. Reston, Virginia: ISOC, November 2007.
- [13] M. Ramadas, S. Burleigh, and S. Farrell. *Licklider Transmission Protocol—Specification*. RFC 5326. Reston, Virginia: ISOC, September 2008.
- [14] *Encapsulation Service*. Issue 2. Recommendation for Space Data System Standards (Blue Book), CCSDS 133.1-B-2. Washington, D.C.: CCSDS, October 2009.
- [15] S. Symington, et al. *Bundle Security Protocol Specification*. RFC 6257. Reston, Virginia: ISOC, May 2011.
- [16] *IOAG Service Catalog #1*. Issue 1 revision 4. Washington, DC: IOAG, June 2013.
- [17] *IOAG Service Catalog #2*. Issue 1 revision 1. Washington, DC: IOAG, June 2013.
- [18] *Space Assigned Numbers Authority (SANA)—Role, Responsibilities, Policies, and Procedures*. Issue 1. CCSDS Record (Yellow Book), CCSDS 313.0-Y-1. Washington, D.C.: CCSDS, July 2011.
- [19] “Registries.” Space Assigned Numbers Authority. <http://sanaregistry.org/r/>.
- [20] *CCSDS Global Spacecraft Identification Field Code Assignment Control Procedures*. Issue 6. Recommendation for Space Data System Standards (Blue Book), CCSDS 320.0-B-6. Washington, D.C.: CCSDS, October 2013.
- [21] *Space Link Extension—Forward CLTU Service Specification*. Issue 3. Recommendation for Space Data System Standards (Blue Book), CCSDS 912.1-B-3. Washington, D.C.: CCSDS, July 2010.
- NOTE – This is an optional standard [Opt] and is to be replaced by F-Frame (reference [D14]) when that is finalized.
- [22] *Space Link Extension—Return All Frames Service Specification*. Issue 3. Recommendation for Space Data System Standards (Blue Book), CCSDS 911.1-B-3. Washington, D.C.: CCSDS, January 2010.
- [23] *Space Link Extension—Return Channel Frames Service Specification*. Issue 2. Recommendation for Space Data System Standards (Blue Book), CCSDS 911.2-B-2. Washington, D.C.: CCSDS, January 2010.

CCSDS RECOMMENDED PRACTICE FOR SPACE COMMUNICATIONS CROSS SUPPORT—
ARCHITECTURE REQUIREMENTS DOCUMENT

- [24] *Delta-Differential One Way Ranging (Delta-DOR) Operations*. Issue 1. Recommendation for Space Data System Practices (Magenta Book), CCSDS 506.0-M-1. Washington, D.C.: CCSDS, April 2011.
- [25] J. Postel and J. Reynolds. *File Transfer Protocol (FTP)*. STD 9. Reston, Virginia: ISOC, October 1985.
- [26] M. Horowitz and S. Lunt. *FTP Security Extensions*. RFC 2228. Reston, Virginia: ISOC, October 1997.
- [27] J. Postel. *Internet Control Message Protocol*. RFC 792. Reston, Virginia: ISOC, September 1981.
- [28] *Space Link Extension—Return Operational Control Fields Service Specification*. Issue 2. Recommendation for Space Data System Standards (Blue Book), CCSDS 911.5-B-2. Washington, D.C.: CCSDS, January 2010.
- [29] *XML Specification for Navigation Data Messages*. Issue 1. Recommendation for Space Data System Standards (Blue Book), CCSDS 505.0-B-1. Washington, D.C.: CCSDS, December 2010.
- [30] *Orbit Data Messages*. Issue 2. Recommendation for Space Data System Standards (Blue Book), CCSDS 502.0-B-2. Washington, D.C.: CCSDS, November 2009.
- [31] *TC Space Data Link Protocol*. Issue 2. Recommendation for Space Data System Standards (Blue Book), CCSDS 232.0-B-2. Washington, D.C.: CCSDS, September 2010.
- [32] *TM Synchronization and Channel Coding*. Issue 2. Recommendation for Space Data System Standards (Blue Book), CCSDS 131.0-B-2. Washington, D.C.: CCSDS, August 2011.
- [33] *Communications Operation Procedure-1*. Issue 2. Recommendation for Space Data System Standards (Blue Book), CCSDS 232.1-B-2. Washington, D.C.: CCSDS, September 2010.
- [34] *Radio Frequency and Modulation Systems—Part 1: Earth Stations and Spacecraft*. Issue 23. Recommendation for Space Data System Standards (Blue Book), CCSDS 401.0-B-23. Washington, D.C.: CCSDS, December 2013.
- [35] *Time Code Formats*. Issue 4. Recommendation for Space Data System Standards (Blue Book), CCSDS 301.0-B-4. Washington, D.C.: CCSDS, November 2010.
- [36] *Pseudo-Noise (PN) Ranging Systems*. Issue 2. Recommendation for Space Data System Standards (Blue Book), CCSDS 414.1-B-2. Washington, D.C.: CCSDS, February 2014.
- [37] *Tracking Data Message*. Issue 1. Recommendation for Space Data System Standards (Blue Book), CCSDS 503.0-B-1. Washington, D.C.: CCSDS, November 2007.

- [38] *Delta-DOR Raw Data Exchange Format*. Issue 1. Recommendation for Space Data System Standards (Blue Book), CCSDS 506.1-B-1. Washington, D.C.: CCSDS, June 2013.
- [39] *CCSDS File Delivery Protocol (CFDP)*. Issue 4. Recommendation for Space Data System Standards (Blue Book), CCSDS 727.0-B-4. Washington, D.C.: CCSDS, January 2007.
- [40] *Conjunction Data Message (CDM)*. Issue 1. Recommendation for Space Data System Standards (Blue Book), CCSDS 508.0-B-1. Washington, D.C.: CCSDS, June 2013.
- [41] *Asynchronous Message Service*. Issue 1. Recommendation for Space Data System Standards (Blue Book), CCSDS 735.1-B-1. Washington, D.C.: CCSDS, September 2011.
- [42] *Space Packet Protocol*. Issue 1. Recommendation for Space Data System Standards (Blue Book), CCSDS 133.0-B-1. Washington, D.C.: CCSDS, September 2003.
- [43] *Proximity-1 Space Link Protocol—Data Link Layer*. Issue 5. Recommendation for Space Data System Standards (Blue Book), CCSDS 211.0-B-5. Washington, D.C.: CCSDS, December 2013.
- [44] *Proximity-1 Space Link Protocol—Physical Layer*. Issue 4. Recommendation for Space Data System Standards (Blue Book), CCSDS 211.1-B-4. Washington, D.C.: CCSDS, December 2013.
- [45] *Proximity-1 Space Link Protocol—Coding and Synchronization Sublayer*. Issue 2. Recommendation for Space Data System Standards (Blue Book), CCSDS 211.2-B-2. Washington, D.C.: CCSDS, December 2013.
- [46] *IP over CCSDS Space Links*. Issue 1. Recommendation for Space Data System Standards (Blue Book), CCSDS 702.1-B-1. Washington, D.C.: CCSDS, September 2012.
- [47] J. Postel. *Internet Protocol*. STD 5. Reston, Virginia: ISOC, September 1981.
- [48] J. Postel. *Transmission Control Protocol*. STD 7. Reston, Virginia: ISOC, September 1981.
- [49] J. Postel. *User Datagram Protocol*. STD 6. Reston, Virginia: ISOC, August 1980.
- [50] R. Fielding, et al. *Hypertext Transfer Protocol -- HTTP/1.1*. RFC 2616. Reston, Virginia: ISOC, June 1999.
- [51] M. Degermark, B. Nordgren, and S. Pink. *IP Header Compression*. RFC 2507. Reston, Virginia: ISOC, February 1999.

CCSDS RECOMMENDED PRACTICE FOR SPACE COMMUNICATIONS CROSS SUPPORT—
ARCHITECTURE REQUIREMENTS DOCUMENT

- [52] *Space Link Extension—Internet Protocol for Transfer Services*. Issue 1. Recommendation for Space Data System Standards (Blue Book), CCSDS 913.1-B-1. Washington, D.C.: CCSDS, September 2008.
- [53] S. Kent and K. Seo. *Security Architecture for the Internet Protocol*. RFC 4301. Reston, Virginia: ISOC, December 2005.
- [54] S. Kent. *IP Encapsulating Security Payload (ESP)*. RFC 4303. Reston, Virginia: ISOC, December 2005.
- [55] E. Rescorla. *HTTP Over TLS*. RFC 2818. Reston, Virginia: ISOC, May 2000.
- [56] *Flexible Advanced Coding and Modulation Scheme for High Rate Telemetry Applications*. Issue 1. Recommendation for Space Data System Standards (Blue Book), CCSDS 131.2-B-1. Washington, D.C.: CCSDS, March 2012.
- [57] *CCSDS Space Link Protocols over ETSI DVB-S2 Standard*. Issue 1. Recommendation for Space Data System Standards (Blue Book), CCSDS 131.3-B-1. Washington, D.C.: CCSDS, March 2013.

And, in the context of this document, the following aggregate references may be used where needed:

[DTN] Delay Tolerant Networking suite, references [3], [D7], [12], [13], [15], [D12], [44], [D24].

[IPS] Internet Protocol suite, references [25], [46], [47], [48], [49], [53].

NOTE – Informative references are contained in annex D.

2 OVERVIEW

2.1 BACKGROUND

Cross support is an activity of using resources of one space agency to support the operations of a space mission of another space agency. To reduce the cost of developing systems for operating space missions, multi-agency cross support arrangements have been used by many space missions. To date, most cross support has been one agency using the ground-based communications assets of another agency. This has already shifted to where agencies are providing cross support for in-space relaying of data; however, these technical and operational arrangements, to date, have been mission-specific and rather ad hoc and idiosyncratic.

To facilitate SCCS, CCSDS developed standard protocols to transfer telecommands (references [8], [9]) and telemetry (references [9], [10]) over space links, which can ensure link layer interoperability between space elements and ground elements belonging to different agencies. CCSDS also developed standard SLE services (references [1], [D6]) to transfer telecommand and telemetry data on the ground (for example, between a ground station and a spacecraft control center), and service management (reference [D10]) as the standard means to request cross support services. By using these CCSDS protocols and services, interoperability between elements of different agencies can be guaranteed to some extent at the link layer; however, coordination and negotiation for cross support is still done in mission-specific, labor-intensive ways. If space internetworking is to become a reality, with cross support and interoperability at higher protocol layers than the space data link, such as internetworking cross support in space, some new protocols and new approaches to mission design will be required.

The SCCS communications architecture defined in this Architecture Requirements Document (ARD) is intended to provide a common framework that is a basis for developing, providing, and using SCCS services. Defining a set of common concepts, common protocols and configurations, and common processes and terminology does this. This architecture is intended to 1) facilitate development of interoperable end-to-end SCCS systems, 2) describe characteristics of SCCS services, and 3) provide examples of protocol stacks for ground and space, including Data Link and Network Layers.

2.2 ROLE OF THIS ARCHITECTURE REQUIREMENTS DOCUMENT

This SCCS-ARD Recommended Practice (Magenta Book) provides the top-level requirements on the architecture elements of SCCS as shown in figure 2-1. The ARD provides concrete guidance and normative subsections that define the required elements, attributes, and behaviors for service interfaces, functional allocations at nodes, protocol stacks, and end-to-end configurations for both ABA and SSI deployments. The accompanying SCCS-ADD Informational Report (Green Book) provides descriptive materials to help understand and explain the concepts.

CCSDS RECOMMENDED PRACTICE FOR SPACE COMMUNICATIONS CROSS SUPPORT—
 ARCHITECTURE REQUIREMENTS DOCUMENT

Each section in this ARD starts by 1) addressing the requirements for simple, single-hop missions that form the bulk of current cross support configurations (ABA configurations), 2) adding what is required to achieve a fully internetworked ‘end game’—a secure, interoperable SSI, and also 3) providing specific requirements on how to architect the building blocks for these missions. This ARD provides requirements on how to architect the building blocks for the ABA systems in a way that can directly serve existing mission modes, the future SSI, and also transitional states between them. This is especially important since these transitional configurations, when correctly constructed, will directly support the future SSI as well as offer useful services for missions that do not need to adopt the full SSI functionality.

Within each section of this document, this ARD addresses each of these operational configurations, along with any transitional information. The intent is to permit users who only require single-hop services to be able to readily find the information they need, while also providing guidance for those who are interested in progressing toward the full SSI.

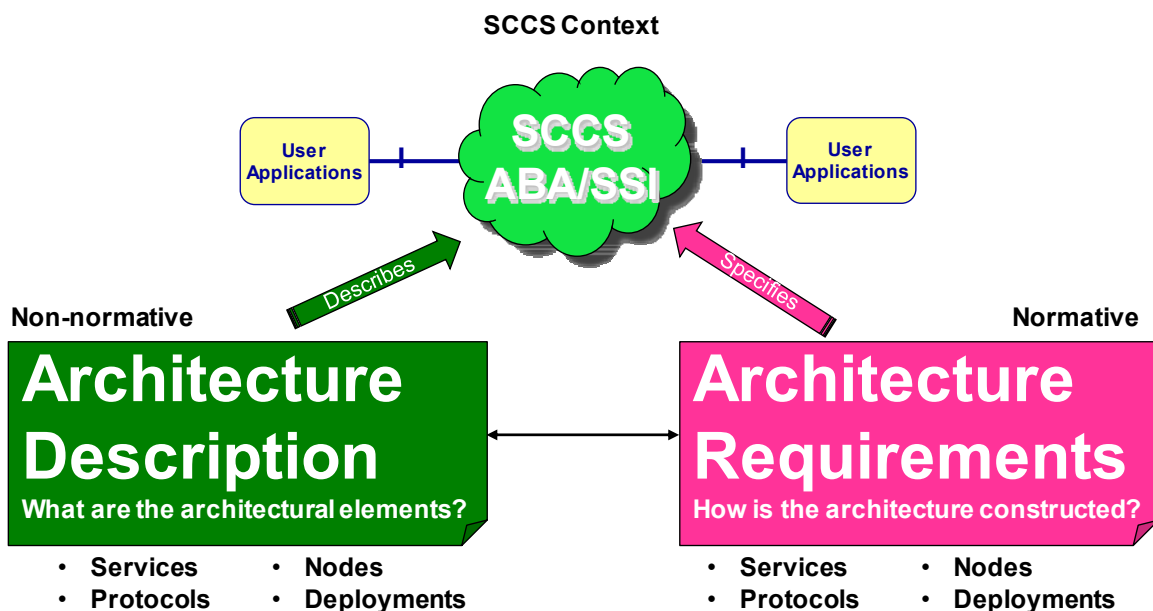

Figure 2-1: Roles of the SCCS Architecture Documents

The companion document, the SCCS-ADD Green Book (reference [D5]), provides rationale, explanatory text, and other descriptive materials. It contains an extensive set of figures that will be referenced in this ARD, and the reader is directed to that document when such additional explanatory materials, such as element architectures and a variety of end-to-end configurations are needed.

This SCCS-ARD defines requirements for developing a multi-agency, interoperable, secure technical architecture for SCCS, including single-hop and internetworked configurations. This document provides requirements on: 1) the service elements from both end-user and service-provider perspectives, 2) the physical elements and building blocks of the SSI, 3) the communications protocols that permit them to operate in end-to-end delivery of service, and 4)

the underlying organizational principles. Section 7 provides requirements for specific end-to-end configurations for single-hop missions, for SSI missions, and for transitional strategies in getting from the present ABA operational state to the future SSI one; this includes mixed-mode states describing how SSI-compliant and non-SSI-compliant missions may interoperate in a limited fashion.

2.3 STRUCTURE OF THE ARD: FOUR VIEWS OF SYSTEM ARCHITECTURE

2.3.1 GENERAL

Large-scale system architectures are complex and must be considered from different perspectives, including both technical and operational views. An architecture that provides multi-agency SCCS services and uses service systems or elements, has many technical and organizational aspects to it. To help make each of these aspects clear, this ARD uses multiple views to define SCCS services and systems, each focusing on different aspects associated with these services and systems.

The views used in this ARD and its companion ADD are:

- a) a service view;
- b) a physical view;
- c) a communications view;
- d) an end-to-end deployment view.

These views were defined based on four of the six viewpoints of the RASDS (reference [2]), which were themselves defined based on the five viewpoints of the Reference Model of Open Distributed Processing (reference [11]). (See those documents for more background on this approach of using distinct viewpoints to describe system architectures.)

2.3.2 SERVICE VIEW

The service view is covered in section 4 and is used to define requirements on services provided by CSSSEs/CSSEs and their behavioral and interface characteristics. Specifically, it addresses the topics of:

- top-level visible service interfaces for key elements;
- means for locating and binding to services;
- top-level interfaces for using services;
- top-level interfaces for managing services.

CCSDS RECOMMENDED PRACTICE FOR SPACE COMMUNICATIONS CROSS SUPPORT—
ARCHITECTURE REQUIREMENTS DOCUMENT

2.3.3 PHYSICAL VIEW

The physical view is addressed in section 5 and defines requirements on the physical configuration of CSSSEs/CSSEs and their functional characteristics. Specifically, it addresses the topics of:

- types of nodes and physical locations;
- allocated functionality at each node;
- physical access to the nodes.

2.3.4 COMMUNICATIONS VIEW

The communications view, which is covered in section 6 defines requirements on communications protocols used for accessing services provided by CSSSEs/CSSEs. Specifically, it addresses the topics of:

- specific interface binding types for each node;
- communications protocol ‘building block’ stacks for each node type;
- relationships between interface bindings and internal functions.

2.3.5 END-TO-END VIEW

The end-to-end view is addressed in section 7 and defines requirements on how to configure the communications protocol building blocks to construct a set of representative mission communications configurations. Specifically, it provides a set of examples covering the following:

- ABA configurations;
- transitional configurations (limited);
- SSI configurations;
- mixed ABA and SSI configurations (limited).

The companion SCCS-ADD Informational Report (reference [D5]), provides an extended set of descriptive materials describing service interfaces, CSSE node configurations, suitable building blocks, and many more end-to-end protocol and system configurations for cross support.

2.3.6 SERVICE-VIEW RELATIONSHIPS

There is an identified relationship among the different elements that appear in each of these views:

- a) The service view shows top-level terrestrial elements that offer or use service interfaces, both terrestrial and for space communications.
- b) The physical view introduces all of the different classes of physical elements (nodes) that are described and their internal functions and behavior. Their interfaces are identified in the physical view, but the interface binding signatures (i.e., the stack of protocols required to actually communicate with them) are specified in the communications view.
- c) The communications view also provides the connection between the interface details and the internal functional details described in the physical views.
- d) The end-to-end view shows how to assemble those nodes, and their protocol stacks, to create mission space communications deployments that will interoperate.

All of these views in this document focus only on the communications protocols up to the Link (ABA) or Network (SSI) Layer. The only Application Layer protocols that are described are those involved in transporting data (files and messages). Mission operations services and other applications protocols are not addressed in this ARD.

2.4 RELATIONSHIPS BETWEEN SCCS AND OTHER CCSDS DOCUMENTS

2.4.1 RELATIONSHIP BETWEEN SCCS AND OTHER CROSS SUPPORT SERVICE DOCUMENTS

The terminology in the SCCS for ABA configurations is derived in part from other cross support service documents, such as the Cross Support Reference Model (CSRM) (reference [1]) and Service Management (reference [D9]) CCSDS Recommended Standards (Blue Books). Because the SSI configuration introduces some new user/provider relationships, and also places cross support elements in space, some new terminology has been required.

This SCCS-ARD has introduced the terms *cross support service element*, *user element*, and *cross support service system* instead of the more limited complex and mission data-operation system terms used in the CSRM. While those CSRM terms are still relevant for ABA cross support configurations, they do not scale for the SSI.

The CSRM concept of *complex management* has been replaced here by *provision management*, which is defined as a set of functions of a CSSS, related to the acquisition and management of services provided by that CSSS to other CSSSes. PM interacts with the UMs of user CSSSes to negotiate the provision of services to their respective CSSSes.

The concept of *service management* has been extended to mean the set of functions exposed by PM to UM for the purposes of acquiring and managing the services provided by the provider CSSS to the user CSSS. Similarly, the concept of *utilization management* has been extended to mean a set of functions of a CSSS or user system, related to the acquisition and management of services provided to that CSSS or user system by other CSSSes.

CCSDS RECOMMENDED PRACTICE FOR SPACE COMMUNICATIONS CROSS SUPPORT—
ARCHITECTURE REQUIREMENTS DOCUMENT

The term *element management* has been introduced to describe functions that interact with PM for purposes of ascertaining element resource availability, configuration and management of element resources, and reporting status of those resources. Elements that perform all or part of the services provided to user CSSSes have EM.

This SCCS-ARD also defines a set of nodes and different node types to support specialized CSSEs, UEs, and their functional configurations and protocol bindings. The CCSDS CSTS (reference [D6]) and next-generation extensible service management book (reference [D10]) introduce the term *functional resource*, which is defined as the functions or capabilities that are provided by physical resources (e.g., transmitters and receivers) of a CSSE, but not those physical resources themselves. A functional resource is a logical construct not necessarily linked to any single system component. Service management manages the functional resources that compose a CSSE. EM manages the elements inside a CSSE or UE that provide services or support user communications functions. Functional Resources are also referenced in the Service Control (reference [D19]) and Monitor Data (reference [D18]) specifications.

NOTE – The existing SM specification (reference [D9]) primarily defines a service request standard, message exchanges, and behavior for command and telemetry services. The new CSSM specification (reference [D10]) defines a more complete, and extensible, set of requests for all TT&C and ancillary and future services. Both are referenced in this document.

2.4.2 RELATIONSHIP BETWEEN SCCS AND OTHER CCSDS APPLICATION LAYER STANDARDS.

This document defines the suite of standards that are assumed to provide the communications services for all other CCSDS Application Layer documents such as SM&C and SOIS. These applications functions, and any other mission- or agency-specific applications, are all treated uniformly as ‘applications functions’. A separate mission operations reference architecture is proposed to be developed for these application functions that primarily run in the Earth and Space User nodes.

2.5 CROSS SUPPORT SERVICE SYSTEM ELEMENTS

2.5.1 GENERAL

In this architecture document, a CSSE is defined to be a physical element that is involved in providing one or more SCCS services, possibly together with some other CSSEs. The nodes that are CSSEs play the service-provider role and are implemented by different service-provider systems. CSSEs functioning together can provide communications and/or navigation services for any space mission element of any space agency provided that the UE conforms to the technical interface specifications and management policies specified for the CSSE.

These service-providing elements are also referred to as ‘building blocks’ because they can be assembled in various ways to provide deployed CSSS services.

A UE is defined to be a physical element that is involved in using one or more SCCS services provided by one or more CSSEs. The nodes that are UEs play the service user role and are implemented by different service user systems. A UE may be adapted to also provide services; when this is done it is then functioning as a CSSE.

A CSSS is defined to be a set of CSSEs or UEs that are managed by a single authority with a single set of management policies. These may be provider or user systems.

2.5.2 CROSS SUPPORT SERVICE ELEMENT

A CSSE may be a landed element on the surface of a heavenly body (e.g., the Earth, the Moon, Mars, Jupiter), an element orbiting around a heavenly body (e.g., a relaying satellite), or an element in cruise through space (e.g., data management systems onboard spacecraft). Table 2-1 shows the types and nominal locations of the different CSSEs described in this document.

Table 2-1: Cross Support Service Elements and Nominal Locations

CSSE Type	Earth	Space/ Orbit	Space/ Planet
ESLT	X		
Earth Routing Node	X		
Space Routing Node		X	
Planet-Space Link Terminal (PSLT)			X
Earth/planet Wide Area Network (WAN) Routing Node	X		X

A CSSE may include a single computer or a large complex consisting of many subsystems. The internal implementation of a CSSE is not visible to its users. What is visible to the users are:

- services (functions) provided for users;
- methods for using and managing the services;
- means for locating and binding to the services;
- physical location or trajectory of the CSSE.

NOTE – For purposes of this document, the Earth is treated separately from the other planets, and the term ‘planet’ is extended to mean any other Solar System body (moon, asteroid, comet) that has missions and associated communications assets.

CCSDS RECOMMENDED PRACTICE FOR SPACE COMMUNICATIONS CROSS SUPPORT—
ARCHITECTURE REQUIREMENTS DOCUMENT

2.5.3 USER ELEMENT

A UE may be a MOC, a landed element on the surface of a heavenly body (e.g., the Earth, the Moon, Mars, Jupiter), an element orbiting around a heavenly body (e.g., a science satellite), or an element in cruise through space. Table 2-2 shows the types and nominal locations of the different UEs described in this document.

Table 2-2: User Elements and Nominal Locations

UE Type	Earth	Space/ Orbit	Space/ Planet
Earth User Node	X		
Space User Node		Varies	Varies
Planet User Node			X
Earth Routing Node	X		

NOTE – The Earth routing node is included in the UE table because acts like a user of the ESLT link layer services and operates as a UE for purposes of planning, scheduling, and controlling the link to the space routing node.

A UE may include a single computer or a large complex consisting of many subsystems. The internal implementation of a UE is not visible to provider systems. What is visible to the provider systems are:

- services required by the UE;
- descriptions of the UE and its interfaces, configurations, and operating constraints;
- requests for locating and binding to the services;
- service requests made by users;
- physical location or trajectory of the UE.

2.5.4 CROSS SUPPORT SERVICE SYSTEMS

A CSSS is defined to be a set of CSSEs that are managed by a single authority with a single set of management policies. A CSSS may be a service provider, a service user, or both. Table 2-3 shows some examples of service provider CSSSes and CSSEs contained in them.

Table 2-3: Examples of Provider Cross Support Service Systems and Related Elements

CSSS	CSSEs
Deep Space Tracking Network	Deep Space Stations, Network Control Center
Near-Earth Tracking Network	Tracking Stations, Network Control Center
Space Relay Tracking Network	Data Relay Satellites, Ground Terminals
Ground Tracking Station	Tracking Station, Station Control Center
Lunar Network	Lunar Relay Satellites
Mars Network	Mars Relay Satellites

Users of the service-provider CSSSes are service-user CSSSes, typically described as a MOC, spacecraft, lander, rover, or other mission element in space. These elements use SCCS services to accomplish their mission objectives. Table 2-4 describes some examples of service user CSSSes and the UEs contained in them.

Table 2-4: Examples of User Cross Support Service Systems and Related User Elements

CSSS	UEs
MOC	Earth User Node, Mission Control Center, Science Center
Spacecraft	Orbiter, Lander, Rover, Hybrid Science/Routing Orbiter

2.6 BASIC SYSTEM-ELEMENT CONFIGURATIONS

2.6.1 ABA SERVICE ELEMENTS—SIMPLE ABA CONFIGURATION

For the usual SCCS service, there is a service UE in space and another service UE on the ground. The ESLT in figure 2-2 is a specialized instance of the generic CSSE. Figure 2-2 shows the basic ABA configuration, with a CSSE of one agency (B) (the ABA ESLT) providing services to the Earth and Space User Nodes of another agency (A). The interface of the CSSE with the service user is called the *service-provider interface*. In this case, there is a terrestrial link service-provider interface to the Earth User Node and a space link service-provider interface to the Space User Node.

CCSDS RECOMMENDED PRACTICE FOR SPACE COMMUNICATIONS CROSS SUPPORT—
 ARCHITECTURE REQUIREMENTS DOCUMENT

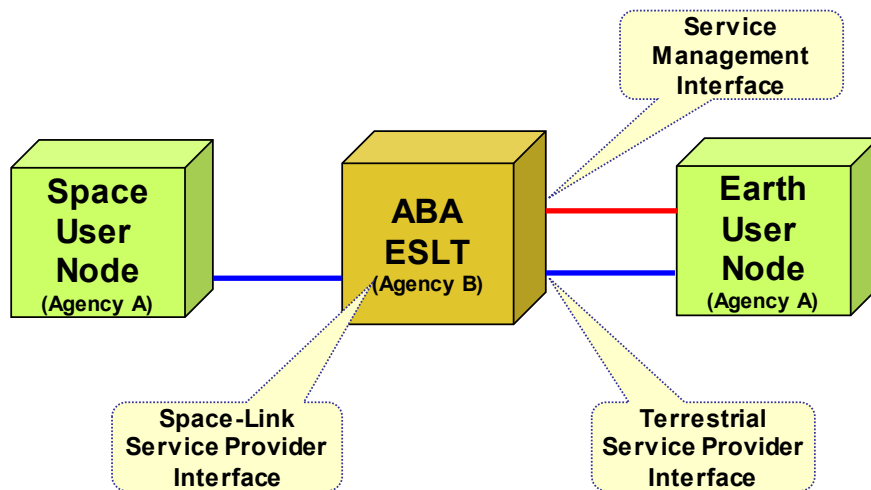

Figure 2-2: Basic ABA Configuration

The Earth and Space User Nodes shown in figure 2-2 are specialized instances of the generic UE. Within the Earth User Node, there will be a *UM element*, which manages, controls, and/or monitors the service provided by a CSSE. The UM element may be within the Earth User Node, but it can be separate, and it may be connected either directly to the interface on the CSSE that permits service management, or to another CSSE that supports the service remotely. The interface of the CSSE with the UM element is called the *service management interface*. (See definitions in 1.6.1.)

In an ABA configuration, a user's primary interfaces to the service provider are the link layer service request and service delivery interfaces either on the ground or in space. Currently the service user produces encoded space link frames for delivery and receives decoded space link frames. Once the F-Frame service is provided, this interface will be symmetric, with the user producing and consuming un-encoded frames. The activities within the service provider and the details of the service production are opaque to the service user, but a certain amount of monitor data and reporting is provided to allow the service user to determine the state of communications.

2.6.2 SSI SERVICE ELEMENTS—CORE SSI CONFIGURATION

In the SSI, there are cases in which a Space User Node and an Earth User Node are supported by two or more CSSEs. Figure 2-3 shows such an example, in which a Space User Node (a spacecraft) and an Earth User Node (e.g., a spacecraft mission control center) are supported by a space routing node (a relay satellite), the ESLT (a communications ground station), and a terrestrial WAN connection. The WAN is really an infrastructure element, and aside from providing Internet Protocol (IP) or Bundle Protocol (BP) network connectivity, it has no other distinguished role in the SSI. The MOC for the space routing node also participates, since it is responsible for managing and configuring the space routing node and for managing the space link to that node that is provided by the CSSE, but it is not necessarily in the direct SSI data flow from Earth User Node to Space User Node.

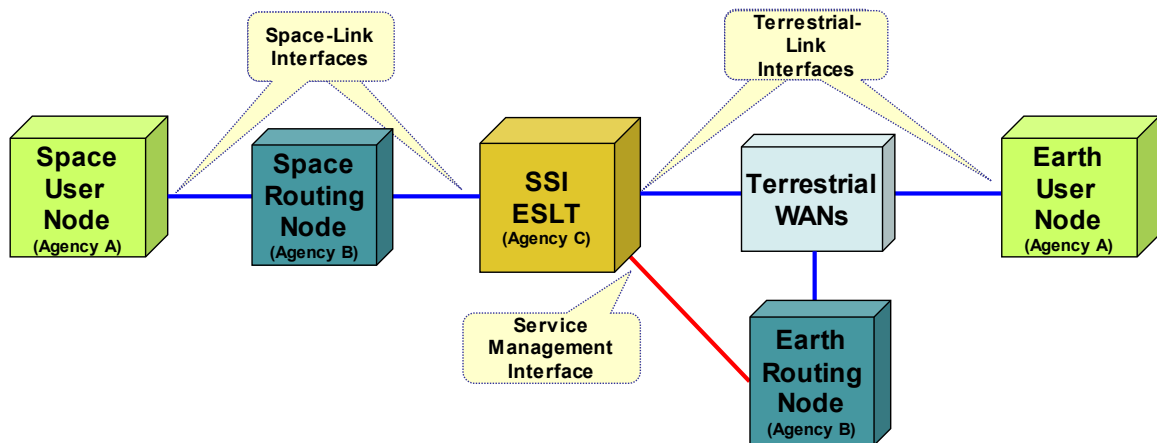

Figure 2-3: SSI Core Configuration

In this document these SSI configurations are also referred to as *ABCBA* style configurations. The notion is that the Earth User Node and the Space User Node both belong to the same agency (A), the space routing node and its MOC may belong to a different agency (B), and the ESLT may belong to yet a different agency (C). So Earth User Node *A*, gets support from the space routing node MOC *B*, connects to ESLT *C*, and then to space routing node *B*, which connects to Space User Node *A*, hence *ABCBA*. Of course, configurations are possible where all of the ABCBA elements may be owned by one agency. The terrestrial WAN may belong to either agency or be a public Internet. In practice the data may not flow directly through the space routing node MOC, but this element is certainly involved in managing the transfer and in controlling the space routing node. Much more complex SSI deployment configurations are possible, but this core SSI ABCBA configuration serves to introduce most of the necessary concepts for any SSI deployment.

2.7 NETWORK TERMINOLOGY

2.7.1 DEFINITION OF A NETWORK

A network consists of one or more computers or other processing elements (such as a spacecraft, data storage device, or other service-providing element) that are owned by a single organization, communicate using a single Layer 3 (Network Layer) protocol (see reference [4]) such as BP or IP, and share a single Layer-2 technology. These elements may communicate directly or may be connected via one or more routers that implement the Network Layer protocol and other support protocols for routing and management of the network. The underlying links from each element to another, or to the router, may differ, but the Network Layer protocol is common across the network.

CCSDS RECOMMENDED PRACTICE FOR SPACE COMMUNICATIONS CROSS SUPPORT—
ARCHITECTURE REQUIREMENTS DOCUMENT

2.7.2 DEFINITION OF AN INTERNETWORK

Internetworking involves connecting two or more distinct computer networks, usually in separate management domains, together to form an internetwork (often shortened to *internetwork*), using routing devices that operate at Layer 3. These routing devices allow traffic to flow back and forth between the networks in a manner that is independent of how each network is implemented, and they guide traffic to its destination, routing data along a suitable path (among several different paths usually available) across the complete Internetwork. An Internetwork is therefore constructed as *a network of networks*. Internetworks may also use protocols at the boundaries of each network to manage flow from one management domain to another.

2.7.3 DEFINITION OF THE SOLAR SYSTEM INTERNETWORK

The SSI (figure 2-4) consists of a loose confederation of independent space communications networks, each often owned and administered by a different space agency. End users of the SSI are given access to internetworked data communications services by the *Solar System Internet Service Provider (SSI-SP)* with which they have established a Service-Level Agreement (SLA). ‘Loose confederation’ means there is no pre-agreed, planned development timeline for the full set of interoperable multi-agency assets that comprise the SSI; rather, the timeline is developed as assets are deployed by different agencies.

The participation of all assets in the SSI, from initiation until end of life, is carefully planned and managed; there is little that is ‘loose’ about it except for the lack of a complete, pre-agreed plan. ‘Confederation’ means that all agencies that choose to participate, each of which is free to act independently, voluntarily come together to collectively form what is effectively a single infrastructure. They do this by adhering to the operating guidelines, standards, protocols, and service interfaces agreed to by the confederation. Each of these independent participating networks is an SSI-SP which may consist of ground (planet or space) communications assets, dedicated routing assets, and/or hybrid science/routing assets. The SSI as a whole provides services to user missions.

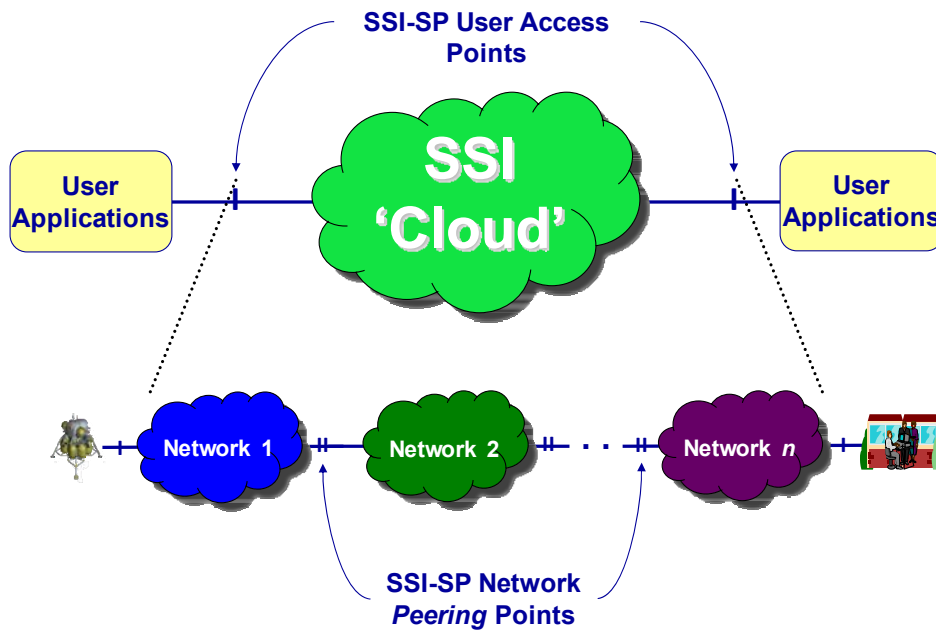

Figure 2-4: The SSI

NOTES

- 1 Applications are identified using Network Layer addresses.
- 2 All application communications go through the Network Layer.
- 3 To applications, there is no difference between a 1-hop, a 2-hop, or a 5-hop network path.

2.7.4 DEFINITION OF DELAY-TOLERANT NETWORKING CONFIGURATIONS

The Delay-Tolerant Networking (DTN) Protocol suite is the primary means recommended to implement the SSI because these protocols are best suited for use in all space communication configurations: deep space, near Earth, and terrestrial. In this document whenever the term 'DTN' is used, this is to be interpreted as the use of the BP (reference [12]) and all other related parts of the DTN suite that are required in that type of deployment. In the case of space links, this includes BP and the associated Store and Forward (S&F) Bundle Protocol Agent (BPA), Licklider Transmission Protocol (LTP) (reference [13]), and Encapsulation (ENCAP) (reference [14]) in order to insert BP PDUs into a CCSDS space link and to provide reliable delivery across that link. In the case of terrestrial hops, this includes BP, the bundle agent, and a convergence layer adapter providing a binding to TCP/IP or possibly User Datagram Protocol (UDP)/IP. Any references to 'Core DTN' are references to these limited DTN protocol stacks and the related functionality that may be deployed in any simple or complex mission configuration using the SSI protocols.

CCSDS RECOMMENDED PRACTICE FOR SPACE COMMUNICATIONS CROSS SUPPORT—
ARCHITECTURE REQUIREMENTS DOCUMENT

The SSI architecture (reference [D7]) describes three different stages of deployments. In Stage 1 there is no expectation that SSI ESLTs or WAN nodes, with full routing and other services, will be available. In this stage SSI UEs will perform any and all SSI functions and will utilize ABA ESLTs to only provide space link access and normal link layer services. All SSI functionality is performed in the user nodes, but these may, by local agreement, provide services to other SSI UEs as well. At the time of this writing, Stage 1 SSI services have already been deployed in more than one space environment for demonstration purposes. These core DTN configurations may also use the Streamlined Bundle Security Protocol (SBSP) (reference [15]) to secure the data and Contact Graph Routing Protocol (CGRP) (reference [D11]) to describe link opportunities for DTN traffic.

For extended SSI configurations a number of additional protocols and configuration information exchanges is required. These are all described in the SSI Architecture as Stage 2 or 3 deployments, and they specifically involve the deployment of SSI functions in the ESLT and the deployment of additional DTN protocols for network management and coordination. At a minimum these extended SSI configurations will include deployment of the DTN Management Protocol (DTNMP, reference [D12]) and some new SSI planning and coordination information exchanges.

The extended SSI will use Network Service Agreements (NSAs) and Extensible Space Communication Cross Support Service Management (ESCCS-SM) requests to arrange for ESLT link layer services. The NSA covers SSI services from the service providing ESLTs, and increasingly automated exchanges for coordination among users, ESLTs, and between ESLTs. The SSI Architecture, for Stages 2 and 3, describes the specific planning and scheduling document exchanges that are to occur among coordinating authorities and within a multi-agency organization called the Coordinating Council. The SSI Architecture should be referenced for these details (see reference [D7]).

2.8 PRACTICAL LIMITS ON PROTOCOL CHOICES

In data communications, Bandwidth Delay Product (BDP) refers to the product of a data link's capacity (in bits per second) and its end-to-end delay (in seconds). The result, an amount of data measured in bits (or bytes), is equivalent to the maximum amount of data on a circuit (network or otherwise) at any given time, i.e., data that has been transmitted but not yet acknowledged. This is calculated as the data link's capacity multiplied by its RTLT.

A network with a large BDP is commonly known as a Long Fat Network (LFN). A network is considered an LFN if its BDP is significantly larger than 105 bits (12500 bytes). Ultra-high-speed LANs fall into this category, where protocol tuning is critical for achieving peak throughput, on account of their extremely high bandwidth, even though their delay is not great.

Of importance for space communications are situations where the BDP is large, such as Geosynchronous Earth Orbit (GEO) satellite connections, where end-to-end delivery time is very high and link throughput may also be high. Other examples in space include what could be called Really Long Skinny Networks (RLSNs). Examples would be IP out to GEO or almost any deep space link. Above some practical limit, like a BDP of 10^6 , the high end-to-end

delivery time makes life difficult for stop-and-wait protocols and applications that assume rapid end-to-end response. Above a BDP of 10^7 , such as in almost all space applications, stop-and-wait, go-back-n, and selective repeat protocols just break, and other approaches for end-to-end reliability must be employed. Table 2-5 provides some example BDPs.

Table 2-5: Example BDPs for Different Earth and Space Applications

Application	Speed (bits/second)	RTLT	BDP
Moderate-speed GEO satellite network	512 kb/s	900 ms	$512 \times 10^3 \text{ b/s} \times 900 \times 10^{-3} \text{ s} = 460,800 \text{ bits}$
Residential ADSL ¹ 2+	20 Mb/s ²	50 ms	$2 \times 10^7 \text{ b/s} \times 5 \times 10^{-2} \text{ s} = 10^6 \text{ b}$, or 1 Mb
High-speed terrestrial network	1 Gb/s	1 ms	$10^9 \text{ b/s} \times 10^{-3} \text{ s} = 10^6 \text{ b}$, or 1 Mb
Earth-to-Moon network	500 Mb/s	2.6 sec	$5 \times 10^8 \text{ b/s} \times 2.6 \text{ s} = 1.3 \times 10^9 \text{ b}$, or 1.3 Gb
L1/L2 orbit	100 Mb/s	210 sec	$10^8 \text{ b/s} \times 2.1 \times 10^2 \text{ s} = 2 \times 10^{10} \text{ b}$, or 20 Gb
Earth trailing orbit	5 Mb/s	20762 sec	$5 \times 10^6 \text{ b/s} \times 2.1 \times 10^4 \text{ s} = 10^{11} \text{ b}$, or 100 Gb
Mars Reconnaissance Orbiter (MRO) to MSL	1 Mb/s	0.008 sec	$10^6 \text{ b/s} \times 8 \times 10^{-3} \text{ s} = 8 \times 10^3 \text{ b}$, or 8000 bits

What is known from real-world experience is that getting TCP/IP to run effectively over GEO satellite links requires quite a bit of acknowledgement window and buffer tuning or use of some specialized protocols like Space Communications Protocol Specification—Transport Protocol (SCPS-TP). Where drawing the distinction is required, this document will use a breakpoint BDP of 10^7 to indicate where certain families of protocols, such as the Internet Protocol Suite (IPS), will cease to work effectively and where other protocol families, such as DTN, should be selected instead. Another practical limit on protocol selection is an RTLT of greater than 2 sec, above which many terrestrial protocols time-out and assume that the link has failed.

2.9 HOW TO USE THIS DOCUMENT

2.9.1 GENERAL

This document covers the broad subject matter of space cross support and protocols, including both ABA and SSI configurations, and does so from a number of different viewpoints. This is a carefully structured architectural approach, but individual users may wish to look at the problem from a different point of view, such as ‘What do I need to implement to construct a compliant ABA ESLT?’ or ‘What do I need to implement to build an SSI-capable spacecraft that can be supported in Stage 1 by an ABA ESLT?’ There will be many such application-specific viewpoints. What this subsection tries to do is to provide a few ‘slices’ through the document to show how such mission or application specific questions may be answered.

¹ Asymmetric Digital Subscriber Line.

² From Digital Subscriber Line Access Multiplexer (DSLAM) to residential modem.

CCSDS RECOMMENDED PRACTICE FOR SPACE COMMUNICATIONS CROSS SUPPORT—
ARCHITECTURE REQUIREMENTS DOCUMENT

2.9.2 DOCUMENT INTERNAL STRUCTURE

Each of the major document sections is generally structured as follows:

- ABA topics:
 - ABA Service Provider (ESLT) topics,
 - ABA Earth User topics,
 - ABA Space User topics;
- SSI topics:
 - SSI Service Provider (ESLT and other Earth and space service provider) topics,
 - SSI Earth User topics,
 - SSI Space User topics;
- Security topics.

Readers who are only interested in ABA topics may safely skip all of the SSI subsections. The reverse is not true, however, as the SSI sections make references back to the ABA ones that they are built upon. Readers who are interested in how to construct a ground station can safely read just the ESLT subsections. They should probably read about the service interfaces first (section 4) and then look at the physical viewpoint (section 5) and the protocol building blocks (section 6).

Readers who are interested in the protocols that a user spacecraft should implement are recommended to read the Space User Node physical viewpoint (section 5) to understand the allocated functionality, and then read the related protocol building blocks (section 6). If they are also concerned with the functionality expected of a spacecraft MOC, they should read the Earth User Node and ESLT service interfaces in section 4 and the related physical viewpoint and allocated functionality in section 5. Table 2-6 provides examples of mission application-specific views.

It is recommended that all readers review the security sections.

Table 2-6: Examples of Mission Application-Specific Views

Topic	Subtopics	SCCS-ARD Sections to Read					
		ABA			SSI		
		Sec 4	Sec 5	Sec 6	Sec 4	Sec 5	Sec 6
ABA Spacecraft and MOC	ABA Spacecraft		5.2.3.3	6.3.1.6			
	ABA MOC	4.2.1 4.2.2	5.2.3.1 5.2.3.2	6.3.1.1 6.3.1.4			
ABA ESLT	ABA ESLT	4.2.2	5.2.2	6.3.1.1			
SSI Spacecraft and MOC	SSI Spacecraft		5.2.3.3	6.3.1.6		5.3.3.3	6.3.2.6
	SSI MOC	4.2.1 4.2.2	5.2.3.1 5.2.3.2	6.3.1.1 6.3.1.4	4.3.2 4.3.3	5.3.2.1 5.3.3.2	6.3.2.2 6.3.2.5
SSI ESLT	SSI ESLT	4.2.2	5.2.2	6.3.1.1			
SSI Stage 1 Spacecraft and MOC	SSI Stage 1 Spacecraft		5.2.3.3	6.3.1.6		5.3.3.3 5.3.3.4	6.3.2.6
	SSI Stage 1 MOC	4.2.1 4.2.2	5.2.3.1 5.2.3.2	6.3.1.1 6.3.1.4		5.3.2.2	6.3.2.4
	SSI Stage 1 ESLT	4.2.2	5.2.2	6.3.1.1			

NOTE – SSI Stage 1 missions will implement all of the SSI functions themselves and that they are using ABA ESLTs only to provide link layer space communications services, not any SSI services.

3 CROSS SUPPORT OVERVIEW OF ABA AND SSI TECHNICAL ARCHITECTURE—CROSS SUPPORT BUILDING BLOCKS

3.1 OVERVIEW

There are two different, but related, types of building blocks that are used to compose space cross support systems: ABA building blocks and SSI building blocks. They differ most importantly in that the ABA building blocks are required only to support up to link layer services, where the SSI building blocks are required to support internetworking services. Service-provider building blocks may be constructed so as to support both ABA and SSI user nodes.

Figure 3-1 shows a representative end-to-end ABA configuration, using ABA building blocks and link layer functions. (See section 5 for more details on the characteristics of these building blocks.)

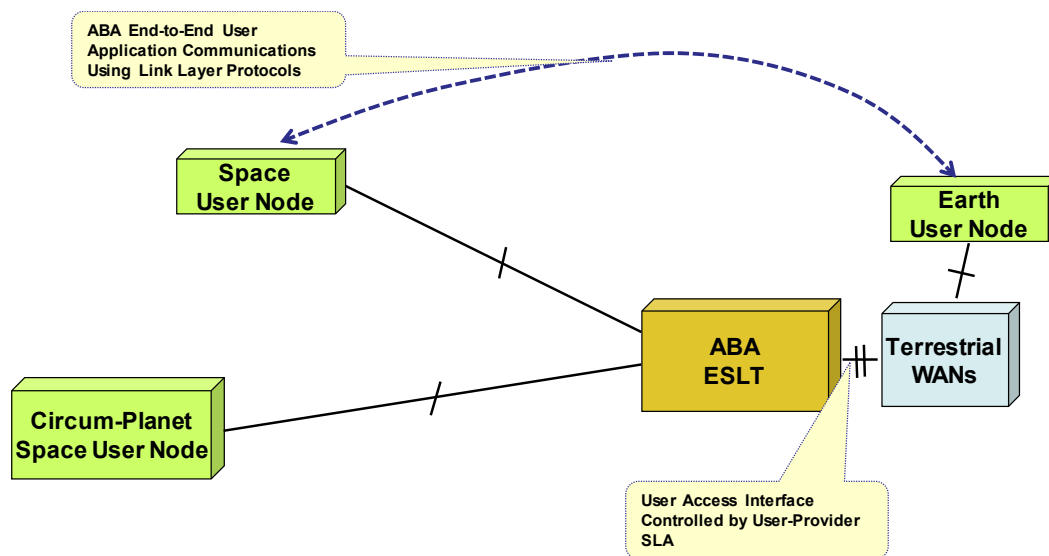

Figure 3-1: Generic ABA End-to-End Deployment

Figure 3-2 shows a representative end-to-end SSI configuration, using SSI building blocks and Network Layer functions. An SSI ESLT is also capable of supporting ABA missions, and that SSI space routing nodes and PSLTs should also be capable of supporting ABA Space User Nodes, using some defined adaptation functions.

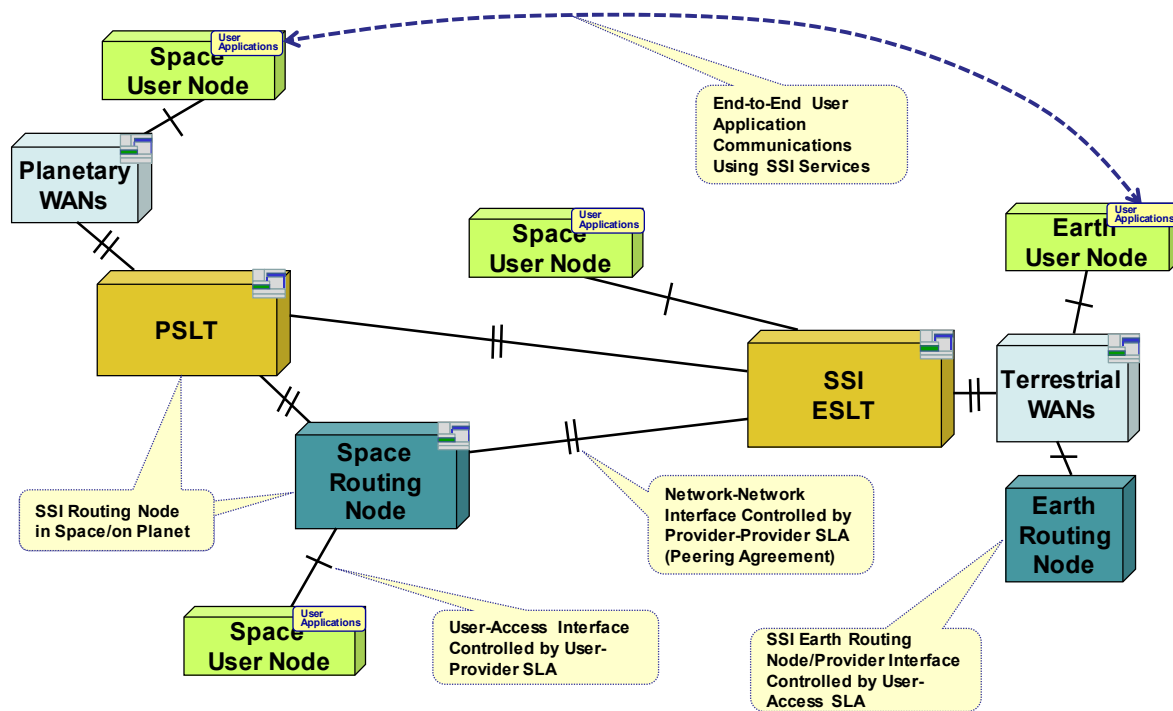

Figure 3-2: Generic SSI End-to-End Deployment

3.2 BUILDING-BLOCK FUNCTIONS

3.2.1 DISCUSSION

Each of the SCCS building blocks (CSSEs) has an associated set of basic functions that distinguishes the blocks one from another. Any of these building blocks may also incorporate other functionality, but the basic functions must be included to enable interoperability. The sets of functions identified here are suitable for both ABA and SSI configurations, but some of the functions are only required to provide SSI services; these are marked as (SSI).

3.2.2 REQUIRED BUILDING-BLOCK FUNCTIONS

The basic sets of functions required for each SCCS building block are as follows:

- a) ESLTs (e.g., ABA and SSI ground stations)
 - shall provide a communications link between terrestrial elements and space elements,
 - shall provide interface to Radio Frequency (RF) space link,
 - shall provide services to one (or possibly more) Earth User Nodes,
 - shall provide full services for link layer processing and frame merging,

CCSDS RECOMMENDED PRACTICE FOR SPACE COMMUNICATIONS CROSS SUPPORT—
ARCHITECTURE REQUIREMENTS DOCUMENT

- shall provide secure access control mechanisms,
 - shall route data between terrestrial elements and space (SSI),
 - shall provide full services for Network Layer processing and routing (SSI),
 - may support last-hop emergency and non-SSI delivery services (SSI),
 - shall provide a service management interface for processing requests, and for service configuration and reporting;
- b) space routing nodes (SSI)
- shall provide routing among space elements,
 - shall provide interfaces to two or more RF space links,
 - shall provide full services for Data Link Layer and Network Layer processing and routing,
 - shall provide security services across their links,
 - must support last-hop emergency and non-SSI delivery services,
 - should have an EM interface for configuration and reporting;
- c) Earth routing nodes (SSI)
- shall operate one or more space routing nodes,
 - may provide routing from Earth User Nodes to their ESLT (but this is not required),
 - may provide interfaces to one or more Earth User Nodes,
 - should provide full services for Data Link Layer and Network Layer processing and routing,
 - must support secure essential commanding and telemetry for the space routing nodes that they operate,
 - should have an EM interface for configuration and reporting;
- d) PSLTs (SSI)
- shall route data between planet surface elements and space,
 - shall provide interfaces to RF space link, either in situ or long haul,
 - may provide interfaces to one or more planet ‘terrestrial’ links,
 - should provide full services, including security, for Data Link Layer and Network Layer processing and routing,

- may support last-hop emergency and non-SSI delivery services,
 - should have a service management interface for processing requests, and for configuration and reporting;
- e) terrestrial WANs (SSI)
- shall route data securely among terrestrial elements (Internet),
 - shall provide interfaces to two or more terrestrial links,
 - shall provide full services for Data Link Layer and Network Layer processing and routing,
 - should have an EM interface for configuration and reporting;
- f) planetary WANs (SSI)
- should route data securely among planet surface elements (Internet),
 - shall provide interfaces to two or more planet ‘terrestrial’ links,
 - shall provide full services for Data Link Layer and Network Layer processing and routing,
 - should have an EM interface for configuration and reporting.

3.2.3 USER NODE REQUIREMENTS

All of the CSSE functionality supports user nodes (UEs), on Earth and in space, including other planet surfaces, which in turn:

- are end-user elements, either in space or on some surface;
- shall use interfaces to either RF space link or terrestrial link;
- shall use basic services for Data Link Layer processing;
- shall use basic services for Network Layer processing (SSI only);
- may use basic security services;
- may provide at least simple routing to next-hop SSI service point (SSI only).

3.2.4 DISCUSSION

The fully compliant SSI CSSEs are all expected to provide full Network Layer and Data Link Layer services and to be capable of routing user data from multiple users simultaneously. All of the SSI service elements can also handle requests from non-SSI nodes operating at the Data Link Layer in ABA-style configurations. Using this approach, fully compliant SSI

CCSDS RECOMMENDED PRACTICE FOR SPACE COMMUNICATIONS CROSS SUPPORT—
ARCHITECTURE REQUIREMENTS DOCUMENT

ESLTs can support ABA and SSI configurations at the same time, but an ESLT with only ABA-compliant services cannot directly support SSI missions except at the link layer (see the Stage 1 configuration in the SSI Architecture) (reference [D7]). The ABA user nodes only need to be able to communicate using link layer services, but they may also implement additional mission-specific protocols above the link layer. The SSI user nodes are only expected to use the minimum necessary Network Layer functions in order to hand off their data to the next hop, which will be an SSI CSSE.

4 SERVICE VIEW

4.1 OVERVIEW

This service view defines service interfaces (space and ground), methods for using services, and cross-supported behavior for planning, scheduling, configuring, requesting, delivering, and reporting on services. The service view also addresses the means for locating and binding to services at Service Access Points (SAPs), including an initial discussion of the roles that protocols play in the binding process. These service interfaces and binding methods are a first compliance point for the architecture.

This service view of the architecture was developed based on the CSRSM (reference [1]), but extends it in such a way that it can be applicable to services provided at places other than ground stations, such as onboard communication/data systems and spacecraft control centers. In the CSRSM, processing of space link protocols by the service provider (which is assumed to be one or more parts of terrestrial service providers) is treated as production of a service on the terrestrial interface to the user (see 4.2.2 in reference [1]). This architecture, however, assumes that production of a service and processing of communications protocols may occur on any of the interfaces of any CSSE, so that services can be defined independently of the location of the service provider, in space, on Earth, or on some other planetary body.

There are two sets of services defined in this section: those suitable for ABA configurations, and those that can also support SSI configurations. The ABA services are primarily the single link services identified in IOAG Service Catalog 1 (reference [16]). The services in Catalog 1 support the single-hop ABA mission configurations. The services defined in Catalog 2 (reference [17]) are defined next as they provide the underpinnings for the SSI upper-layer space internetworking services (ABCBA configurations). This ARD assumes that the SLE (reference [1]) and CSTS (reference [D6]) protocols will be used to define the link layer service interfaces for all ESLTs operated by any space agencies or other, possibly commercial, service providers. It also assumes that the CCSDS Service Management (SCCS-SM) protocols (reference [D10]) will be used to plan, schedule, configure, and control services. Until the concept of reference [D10] is fully developed, service management functions will typically be handled by bilateral agreements between service provider and service user.

Service interfaces that are planned, but still under development, are included for completeness, so that the future directions of CCSDS are clear. These interfaces are marked [Future] in the text. Any interfaces that are considered optional are marked [Opt]. All others are required.

CCSDS RECOMMENDED PRACTICE FOR SPACE COMMUNICATIONS CROSS SUPPORT—
 ARCHITECTURE REQUIREMENTS DOCUMENT

4.2 ABA SERVICES

4.2.1 OVERVIEW

The service interfaces provided to ABA missions are represented in figure 4-1. Subsection 4.2 of SCCS-ADD (reference [D5]) contains more descriptive information on ABA service interfaces. All requirements in this subsection, except those marked [Opt] or [Future], should be implemented by ABA compliant systems. Once [Future] standards are formally adopted, this document will be updated.

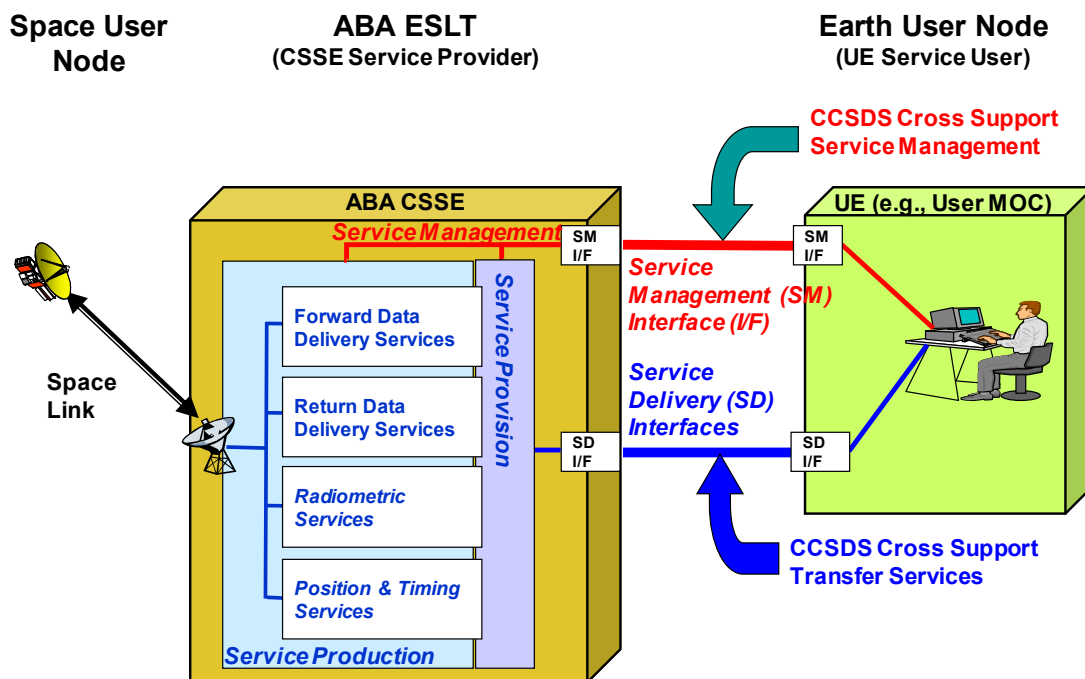

Figure 4-1: ABA Service Interfaces

ABA Earth User Nodes are responsible for planning, scheduling, configuring, and controlling the elements that provide space link services for their spacecraft. They are also the source and sink for data sent to/from the spacecraft.

Throughout this document the requirements are stated as applicable to full compliance with recommended CCSDS usage. In many cases these standard services and protocols can be used in ways that do not completely align with recommended practice. An example is the permitted practice of using the F-CLTU service to deliver a command bitstream to a spacecraft that in no way complies with CCSDS space link protocols, SCID, or other forward link protocols. There is no attempt made in the document to describe all of these possible variations from the norm. Users of these standards should refer to the individual specifications for such flexibilities.

4.2.2 ABA EARTH USER SERVICE REQUIREMENTS

4.2.2.1 Current ABA Earth User Service Requirements

4.2.2.1.1 ABA Earth User Nodes shall provide CCSDS-compliant credentials to access all service user interfaces (reference [7]).

4.2.2.1.2 ABA Earth User Nodes shall acquire a Spacecraft Identifier (SCID) from SANA (references [18], [19]) using the Global Spacecraft Identifier (GSCID) assignment procedure (reference [20]).

NOTES

- 1 This document defines CCSDS recommended practice. Not all spacecraft may use registered SCIDs. They make these deviations from the norm at their own risk.
- 2 The SANA is used as a shorthand and because it provides a pointer to all of the operational registries that may be referenced programmatically. Only specific registries will be referenced for any given purpose and these may be off-line or on-line references.

4.2.2.1.3 ABA Earth User Nodes shall use bilateral service management agreements to plan, schedule, request, and configure space communications services.

4.2.2.1.4 ABA Earth User Nodes shall use bilateral service management agreements to submit trajectory and/or orbit files required to track their spacecraft.

4.2.2.1.5 ABA Earth User Nodes shall use the SLE Forward-Communication Link Transmission Unit (F-CLTU) service-user interface (reference [21]) to send Communication Link Transmission Units (CLTUs) to their Space User Nodes.

4.2.2.1.6 [Opt] ABA Earth User Nodes requiring Advanced Orbiting Systems (AOS) forward services should use [Opt][Future] CSTS F-Frame (reference [D14]) to send AOS frames or CLTUs to their Space User Nodes.

NOTE – Current missions requiring forward AOS could use the experimental SLE EF-CLTU (reference [D13]).

4.2.2.1.7 ABA Earth User Nodes shall use the SLE Return All Frame (RAF) service-user interface (reference [22]) to receive all channel frames sent from their Space User Nodes.

4.2.2.1.8 ABA Earth User Nodes shall use the SLE Return Channel Frame (RCF) service-user interface (reference [23]) to receive selected channel frames sent from their Space User Nodes.

4.2.2.1.9 ABA Earth User Nodes may use the SLE Return Operational Control Field (ROCF) service-user interface (reference [28]) to receive CLCWs sent from their Space User Node in near real time.

NOTE – ROCF is useful when there is not enough bandwidth to return all of the frames reliably in near-enough real time need to get the CLCWs needed to close the COP.

CCSDS RECOMMENDED PRACTICE FOR SPACE COMMUNICATIONS CROSS SUPPORT—
ARCHITECTURE REQUIREMENTS DOCUMENT

4.2.2.2 Future ABA Service User Requirements

4.2.2.2.1 [Future] ABA Earth User Nodes shall use the ESCCS-SM interface (reference [D10]) to plan, schedule, request, and configure new space communications services.

4.2.2.2.2 [Future] ABA Earth User Nodes shall use a CCSDS Service Catalog interface (reference [D10]) to identify and characterize available space communications services.

4.2.2.2.3 [Future] ABA Earth User Nodes shall use a CCSDS service-agreement interface (reference [D10]) to define and arrange for delivery of space communications services.

4.2.2.2.4 [Future] ABA Earth User Nodes shall use a CCSDS spacecraft configuration interface (reference [D10]) to describe the communication configurations of their spacecraft and space communications services.

4.2.2.2.5 [Future] ABA Earth User Nodes shall use a CCSDS network schedule interface (reference [D10]) to determine expected times for scheduled space communications services.

4.2.2.2.6 [Future] ABA Earth User Nodes should use the CSTS Forward Frame (F-Frame) service-user interface (reference [D14]) to send Telecommand (TC) or AOS frames to their Space User Nodes.

4.2.2.2.7 [Future] ABA Earth User Nodes may request a Delta-DOR service (reference [24]) via the ESCCS-SM (reference [D10]) service-user interface.

4.2.2.2.8 [Future] ABA Earth User Nodes should use the CSTS CFDP Forward/Return File Service (file to/from CFDP) (reference [D15]) to send files to/from their Space User Nodes via the CSTS transfer file service -user interface (reference [D17]).

4.2.2.2.9 [Future] ABA Earth User Nodes may use the CSTS transfer file service -user interface (reference [D17]) to retrieve off-line tracking data and Delta-DOR processed data files.

4.2.2.2.10 [Future] ABA Earth User Nodes should use the CSTS tracking data service-user interface (reference [D16]) to receive real-time radiometric data.

4.2.2.2.11 [Future] ABA Earth User Nodes should use the CCSDS CSTS monitor data service-user interface (reference [D18]) to monitor service provider and link status.

4.2.2.2.12 [Future] ABA Earth User Nodes should use the CSTS service control service-user interface (reference [D19]) to request service provider parameter changes.

4.2.2.2.13 [Future] ABA Earth User Nodes should use the ESCCS-SM (reference [D10]) user interface to request and access service accountability reports.

4.2.3 ABA SERVICE PROVIDER REQUIREMENTS

4.2.3.1 Current ABA Service Provider Requirements

4.2.3.1.1 ABA ESLTs shall assign CCSDS-compliant credentials to mission users as part of the service agreement process (references [7], [D9]).

4.2.3.1.2 ABA ESLTs should verify that a valid SCID (reference [20]) is being presented using the SANA (references [18], [19] or some local cache of valid SCIDs.

4.2.3.1.3 ABA ESLTs shall provide the CCSDS service management, service-provider interface (reference [D9]) to plan, schedule, request, and configure space communications services.

4.2.3.1.4 ABA ESLTs shall permit one and only one ABA Earth User Node to plan, schedule, request, and configure space communications services for a given space link instance.

4.2.3.1.5 ABA ESLTs shall provide the CCSDS service-management service-provider interface (reference [D9]) to accept trajectory and/or orbit files required to track user spacecraft.

4.2.3.1.6 ABA ESLTs shall permit one and only one ABA Earth User Node to use forward service-provider interfaces for a given space link instance.

4.2.3.1.7 ABA ESLTs shall provide the SLE F-CLTU service-provider interface (reference [21]) for forward data delivery.

4.2.3.1.8 ABA ESLTs may provide [Opt][Future] CSTS F-Frame (reference [D14]) for users requiring forward AOS services.

4.2.3.1.9 ABA ESLTs shall support more than one simultaneous ABA Earth User Node to use the return service-provider interfaces for a given space link instance.

4.2.3.1.10 ABA ESLTs shall provide the SLE RAF service-provider interface (reference [22]) for return data delivery.

4.2.3.1.11 ABA ESLTs shall provide the SLE RCF service-provider interface (reference [23]) for return data delivery.

4.2.3.1.12 ABA ESLT should provide the SLE Return Operational Control Field (ROCF) service-provider interface (reference [23]) to return CLCWs in near real time.

CCSDS RECOMMENDED PRACTICE FOR SPACE COMMUNICATIONS CROSS SUPPORT—
ARCHITECTURE REQUIREMENTS DOCUMENT

4.2.3.2 Future ABA Service Provider Requirements

4.2.3.2.1 [Future] ABA ESLTs shall accept CCSDS-compliant credentials to authenticate access to all service-provider interfaces (references [1], [7], [D6], [D10]).

4.2.3.2.2 [Future] ABA ESLTs shall provide the ESCCS-SM service-provider interface (reference [D10]) to plan, schedule, request, and configure new space communications services.

4.2.3.2.3 [Future] ABA ESLTs shall provide a CCSDS service-provider catalog interface (reference [D10]) to specify and characterize available space communications services.

4.2.3.2.4 [Future] ABA ESLTs shall provide a CCSDS service-agreement interface (reference [D10]) to define and arrange for delivery of space communications services.

4.2.3.2.5 [Future] ABA ESLTs shall provide a CCSDS spacecraft configuration service-provider interface (reference [D10]) to accept descriptions of the communication configurations of user spacecraft and space communications services.

4.2.3.2.6 [Future] ABA ESLTs shall provide a CCSDS network schedule service-provider interface (reference [D10]) to identify the expected times for scheduled space communications services.

4.2.3.2.7 [Future] ABA ESLTs should provide the CSTS F-Frame service-provider interface (reference [D14]).

4.2.3.2.8 [Future] ABA ESLT implementing the F-Frame functions should permit more than one simultaneous ABA Earth User Node or service element to use the F-Frame service-provider interface.

4.2.3.2.9 [Future] ABA ESLTs may provide a Delta-DOR service (reference [24]) requested via the ESCCS-SM (reference [D10]) service-provider interface.

4.2.3.2.10 [Future] ABA ESLTs should provide the CSTS CFDP Forward/Return-File service (reference [D15]) (file to/from CFDP) via the CSTS transfer file service-provider interface (reference [D17]).

4.2.3.2.11 [Future] ABA ESLTs should provide the CSTS transfer file service-provider interface (reference [D17]) to deliver off-line tracking data and Delta-DOR (reference [24]) processed data files.

4.2.3.2.12 [Future] ABA ESLTs should provide the CSTS tracking data service-provider interface (reference [D16]).

4.2.3.2.13 [Future] ABA ESLTs should provide the CSTS monitor data service-provider interface (reference [D18]).

4.2.3.2.14 [Future] ABA ESLTs should provide the CSTS service control service-provider interface (reference [D19]).

4.2.3.2.15 [Future] ABA ESLTs shall permit one and only one ABA Earth User Node to use the service control service-provider interface for a given space link.

4.2.3.2.16 [Future] ABA ESLTs should provide the ESCCS-SM (reference [D10]) service-provider interface to accept requests and deliver service accountability reports.

NOTE – Current networks offer similar file transfer services to those described in this subsection, but directly using File Transfer Protocol (FTP) (reference [25]) or secure FTP (reference [26]). The future CSTS transfer file service is likely to adopt a similar approach, and it is expected to include specifications for associated meta-data and file handling.

4.3 SSI SERVICES

4.3.1 OVERVIEW

4.3.1.1 SSI Service Interfaces

The fundamental SSI service for DTN is the end-to-end delivery of bundles to the destination(s) specified by their destination Endpoint Identifiers. For IPS it is the analogous delivery of IP datagrams to endpoint addresses. The service interfaces provided to SSI missions are represented in figure 4-2. Subsection 4.3 of the SCCS-ADD (reference [D5]) contains more descriptive information on SSI service interfaces.

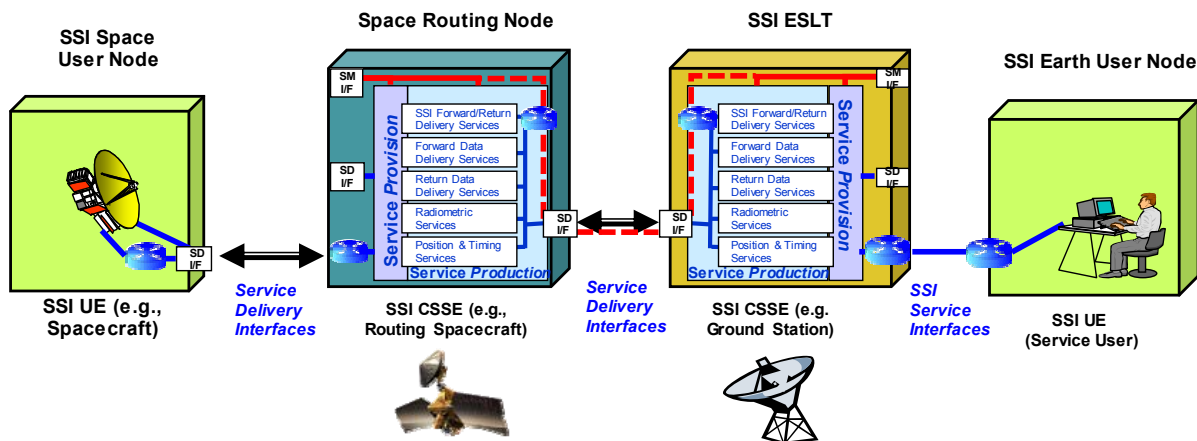

Figure 4-2: SSI End-to-End Run-Time Service Interfaces

The service interfaces used by the SSI Earth Routing Node and SSI ESLT that are SSI service providers to SSI missions are represented in figure 4-3. Once these underlying space links are in place SSI User Elements may just use them.

CCSDS RECOMMENDED PRACTICE FOR SPACE COMMUNICATIONS CROSS SUPPORT—
ARCHITECTURE REQUIREMENTS DOCUMENT

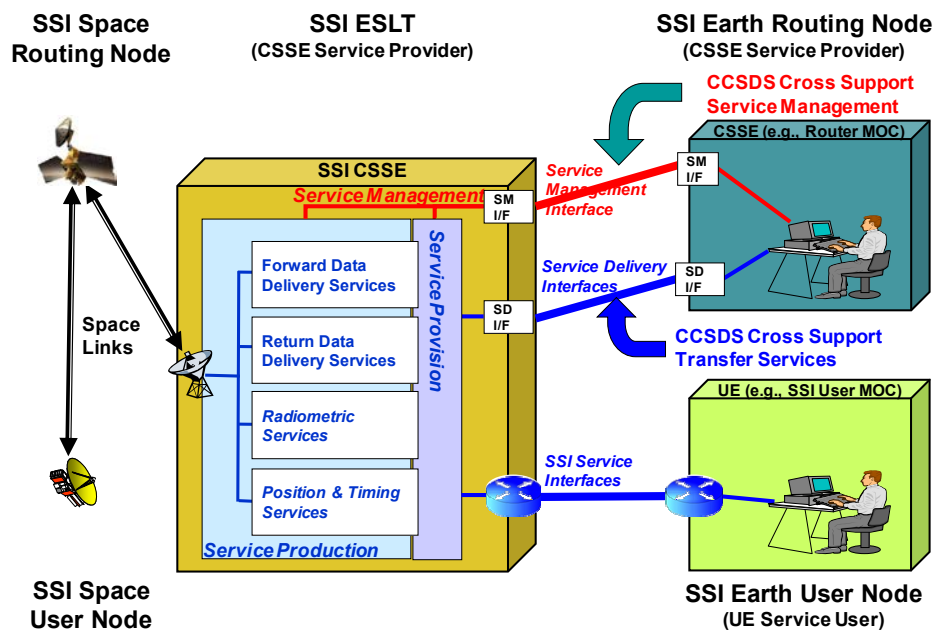

Figure 4-3: SSI ESLT Service Interfaces for Earth Routing Node

4.3.1.2 SSI Service Configuration

Service provider nodes in SSI Stage 2 or 3 configurations (see reference [D7]) use many of the underlying ABA capabilities to establish the space links to space routing nodes and users. The SSI networking services are similar to those offered by an Internet Service Provider (ISP), instead of simple telecommunications link services. The significant difference between a terrestrial ISP and the SSI is the continuing need to schedule and choreograph the underlying space communication links over which SSI traffic flows. In SSI configurations, as with ABA services, there is also the need to design services and applications with an awareness of the time delays and link disconnections that are driven by the physics of space operations. In the SSI there is a distinction between the service user nodes, of which there may be several, and the service provider nodes. The SSI service-provider's primary view of the network is the service request and delivery interfaces on the ground and the service-provider interfaces in space.

What the SSI service user sees is an SSI-compliant network service router interface, essentially a space ISP (SSI-ISP). This interface may be implemented by software in a computer local to the user or in a separate local router. Between the SSI service user's local router and the destination, there may be network services provided by other SSI-ISPs, but these should be transparent to the end user (aside from delays due to physics and availability of communications contacts). SSI user nodes may also be SSI service provider nodes as well. This is very similar to the Internet, where all users need to be concerned with, as they hook up a laptop in some random WiFi hotspot, is the local ISP that provides that end-user connection service. All of the other transcontinental or transoceanic ISPs, transport services, circuits, security, and routers are invisible to the users unless they probe for them or they fail.

All accesses to SSI service-provider facilities—for planning, scheduling, service invocation and execution—are secured at the interfaces; only authorized users are permitted access. Network Layer security services may be provided, using SSI Streamlined Bundle Security Protocol (SBSP) or Internet Protocol Security (IPSec) protocols. Furthermore, users may apply Application Layer authentication and encryption as required, but this is opaque to the service providers. In the future all requirements in this section, including the ones marked [Future], once they are formal standards, should be implemented by SSI compliant systems.

In SSI Stage 1 deployments (see reference [D7]) all of the SSI service provider functions are performed by user nodes and the ESLTs are only required to offer standard ABA services.

4.3.2 FUTURE SSI SERVICE USER REQUIREMENTS

4.3.2.1 [Future] SSI Earth or Space User Nodes shall connect to the SSI via an SSI-ISP (reference [DTN] or [IPS]).

4.3.2.2 [Future] SSI Earth or Space User Nodes with intermittent link connectivity, BDP $>10^7$, or long RTLT (>2 seconds) shall use the basic DTN internetworking service interfaces.

4.3.2.3 [Future] SSI Earth or Space User Nodes with continuous link connectivity, BDP $<10^7$ and short RTLTs (<2 seconds) shall use one of the basic IP or DTN internetworking service interfaces.

4.3.2.4 [Future] SSI Earth or Space User Nodes shall use an NSA to establish a support agreement with an SSI-ISP (reference [DTN] or [IPS]) (reference [D7]).

4.3.3 FUTURE SSI SERVICE-PROVIDER REQUIREMENTS

4.3.3.1 SSI Earth-Based Service-Provider Requirements

4.3.3.1.1 [Future] SSI ESLTs shall provide all of the required ABA ESLT service interfaces (see 4.2.3).

4.3.3.1.2 [Future] SSI ESLTs shall provide SSI-ISP services to SSI users (reference [DTN] or [IPS]) (reference [D7]).

4.3.3.1.3 [Future] SSI ESLTs shall provide CCSDS-compliant DTN internetworking, routing, and forwarding service interfaces.

4.3.3.1.4 [Future] SSI ESLTs may provide CCSDS-compliant IP internetworking and routing service interfaces (reference [IPS]).

4.3.3.1.5 [Future] SSI ESLTs shall provide the CCSDS CSTS F-Frame service-provider interface (reference [D14]) to do frame processing and merging.

CCSDS RECOMMENDED PRACTICE FOR SPACE COMMUNICATIONS CROSS SUPPORT—
ARCHITECTURE REQUIREMENTS DOCUMENT

4.3.3.1.6 [Future] SSI ESLTs shall use an NSA to establish a support agreement with SSI users (reference [DTN] or [IPS]) (reference [D7]).

4.3.3.1.7 [Future] SSI ESLT should use a Peering Agreement (PA) to establish a support agreement with other SSI service providers (reference [DTN] or [IPS]) (reference [D7]).

4.3.3.1.8 [Future] SSI ESLTs must provide one or more internetworking management service interfaces (references [D12], [27]) to control space internetworking.

4.3.3.1.9 [Future] SSI ESLTs shall provide a CCSDS network schedule interface (reference [D10]) to identify the expected times for scheduled space internetworking services.

4.3.3.1.10 [Future] SSI ESLTs shall provide a CCSDS service-agreement interface (reference [D10]) to define and arrange for delivery of space internetworking services.

4.3.3.1.11 [Future] SSI ESLTs shall provide a CCSDS Service Catalog interface (reference [D10]) to specify and characterize available space internetworking services.

4.3.3.1.12 [Future] SSI ESLTs shall participate in an SSI coordinating function (reference [D7]) to perform SSI network planning and management functions.

4.3.3.2 SSI Earth Routing Node Service-Provider Requirements

4.3.3.2.1 [Future] SSI Earth routing node should utilize the ABA ESLT service-provider interfaces (see 4.2.3) to manage and control its space routing node.

4.3.3.2.2 [Future] SSI Earth routing node shall provide SSI-ISP services to SSI users (reference [DTN] or [IPS]) (reference [D7]).

4.3.3.2.3 [Future] SSI Earth routing node should provide CCSDS-compliant DTN internetworking, routing, and forwarding service interfaces (reference [DTN]).

4.3.3.2.4 [Future] SSI Earth routing node may provide CCSDS-compliant IP internetworking and routing service interfaces (reference [IPS]).

4.3.3.2.5 [Future] SSI Earth routing node shall utilize the ESLT CCSDS CSTS F-Frame service-user interface (reference [D14]) to do frame processing and merging.

4.3.3.2.6 [Future] SSI Earth routing node should use an NSA to establish a support agreement with SSI users (reference [DTN] or [IPS]) (reference [D7]).

4.3.3.2.7 [Future] SSI Earth routing node should use a PA to establish a support agreement with other SSI service providers (reference [DTN] or [IPS]) (reference [D7]).

4.3.3.2.8 [Future] SSI Earth routing node must provide one or more internetworking management service interfaces (references [D12], [27]) to control space internetworking.

4.3.3.2.9 [Future] SSI Earth routing node shall provide a CCSDS network schedule interface (reference [D10]) to identify the expected times for scheduled space internetworking services.

4.3.3.2.10 [Future] SSI Earth routing node shall provide a CCSDS service-agreement interface (reference [D10]) to define and arrange for delivery of space internetworking services.

4.3.3.2.11 [Future] SSI Earth routing node shall participate in an SSI coordinating function (reference [D7]) to perform SSI network planning and management functions.

4.3.3.3 SSI Space-Based Service-Provider Requirements

4.3.3.3.1 [Future] SSI space routing node shall provide SSI-ISP services to SSI users (reference [DTN] or [IPS]).

4.3.3.3.2 [Future] SSI space routing nodes shall provide one or more CCSDS-compliant basic internetworking services (reference [DTN] or [IPS]).

4.3.3.3.3 [Future] SSI space routing nodes with intermittent link connectivity, $BDP > 10^7$, or long RTLTs (> 2 seconds) should provide DTN internetworking services. (This is a sub-requirement of 4.3.3.2.6 above.)

4.3.3.3.4 [Future] SSI space routing nodes with continuous link connectivity, $BDP < 10^7$, and short RTLTs may provide the basic IP internetworking services (reference [IPS]). (This is a sub-requirement of 4.3.3.2.6 above.)

4.3.3.3.5 [Future] SSI space routing nodes must provide one or more internetworking management service interfaces (references [D12], [27]) to control the space relay asset.

4.3.3.3.6 [Future] SSI space routing node should use a PA to establish a support agreement with other SSI service providers (reference [DTN] or [IPS]) (reference [D7]).

4.3.4 FUTURE SSI LAST-HOP SERVICE-PROVIDER REQUIREMENTS

4.3.4.1 [Future] SSI space routing nodes should provide the last-hop and first-hop services (reference [D20]). (See 6.2.4.)

4.3.4.2 [Future] SSI Earth routing nodes should support the last-hop and first-hop services (reference [D20]). (See 6.2.4.)

4.3.4.3 [Future] SSI ESLTs may provide the last-hop and first-hop services (reference [D20]).

CCSDS RECOMMENDED PRACTICE FOR SPACE COMMUNICATIONS CROSS SUPPORT—
ARCHITECTURE REQUIREMENTS DOCUMENT

4.4 SECURITY REQUIREMENTS FOR SERVICES

4.4.1 OVERVIEW

The system elements that provide user services will typically be secured in a number of ways, both physically and logically. The security requirements that follow below should be employed in the implementation of service systems.

4.4.2 REQUIREMENTS

4.4.2.1 All ESLTs service interfaces should be secured and require CCSDS-compliant access credentials (references [6], [7]).

4.4.2.2 All ESLT users should be required to login to the system management interfaces in order to plan and schedule services (references [6], [D10]).

4.4.2.3 All ESLT users should be required to login to the system management interfaces in order to request, monitor, and control services (references [6], [D10]).

4.4.2.4 All ESLT users should be required to login to the service execution interfaces in order to send and receive data (references [6], [21], [22], [23], [D14], [D16], [D17], [D18], [D19], [28]).

4.4.2.5 Each mission user should be required to establish their own user credentials with the service provider before services may be accessed (reference [7]).

4.4.2.6 Different mission users may have different roles.

4.4.2.7 Mission users should be required to establish a service agreement (reference [D10]) with the service provider before services may be requested.

NOTES

- 1 The SM and SLE interfaces have provision for security, but they do not mandate their use. Requirement 4.4.2.1 levies a stronger requirement on the service providers.
- 2 The security sections of the SLE, CSTS, and service management documentation (references [1], [D6], [D9]), and the security architecture and cryptographic algorithms documents (references [6], [7]) contain more details about service security interfaces and appropriate authentication approaches.
- 3 Physical security is addressed in section 5; other types of communication link security, such as link encryption, are addressed in section 6.

5 PHYSICAL VIEW

5.1 OVERVIEW

The physical elements (nodes) of a deployed CSSS embody a set of functions that implement the behavior exhibited by the CSSEs and UEs that compose the system. The external interfaces of these functions are the services whose requirements are defined in section 4. This physical view section is used to define 1) the expected physical configuration of CSSSes/CSSEs/UEs and their physical characteristics, 2) the allocation of functionality to these different physical elements, and 3) the security requirements for physical elements of a deployed CSSS.

A physical element may be an element on the surface of a heavenly body (e.g., the Earth, the Moon, or Mars), an element orbiting around a heavenly body, or an element in cruise through space. Examples of physical elements are orbiting spacecraft (deep-space and near-earth), landed elements on the Moon or Mars, data management systems onboard spacecraft, ground stations, control centers, and computers at control centers. The physical elements that are CSSEs are referred to as building blocks, since they are used to build end-to-end systems configurations.

SCCS involves several types of physical elements, ranging from individual hardware elements such as antennas, receivers, and computers, to large or complex elements such as tracking stations, control centers, and spacecraft. Limited descriptions of physical elements are provided in this ARD. The companion SCCS-ADD document (reference [D5]) contains the internal details of physical elements, which even in that document are described only where they are necessary for explaining how cross support services are provided.

The concept of functional resources is defined within the ESCCS-SM (reference [D10]) and CSTS Framework (reference [D6]). Functional resources can be viewed as those key aspects of typical command, ranging, and telemetry systems necessary for providing these services to and from mission spacecraft. Functional resources are used to define the configuration parameters, control parameters, monitored parameters, and notifiable events of the space communication and tracking resources used to provide space communication and tracking services. One or more of these functional resources provides the functionality within each node type addressed in this section; for simplification, they are treated in aggregate form within this document.

CCSDS RECOMMENDED PRACTICE FOR SPACE COMMUNICATIONS CROSS SUPPORT—
 ARCHITECTURE REQUIREMENTS DOCUMENT

5.2 ABA-SPECIFIC ELEMENTS

5.2.1 OVERVIEW

5.2.1.1 General

This subsection defines the ABA CSSE and UE nodes and the functions they are expected to implement. A generic physical model of an ABA building block is presented in figure 5-1, followed by the requirements on CSSEs and UEs that are used to compose ABA end-to-end systems.

Regardless of the specific details of how they are implemented, all the core link layer functionality (link layer processing, data forwarding, and EM) shown in this generic ABA building block will be included in every ABA node. ABA end-user nodes, in space or on ground, will typically have only one link, one or more applications, will use local means to do EM, and use formal element (utilization) management interfaces terrestrially. ABA service-providing building blocks will typically have two links (one terrestrial and one in space), will have managed data-forwarding functionality, will offer formal element (provision) management interfaces, and may have specialized local applications.

The full suite of ABA physical node types is described in more detail in subsection 5.2 of the SCCS-ADD (reference [D5]).

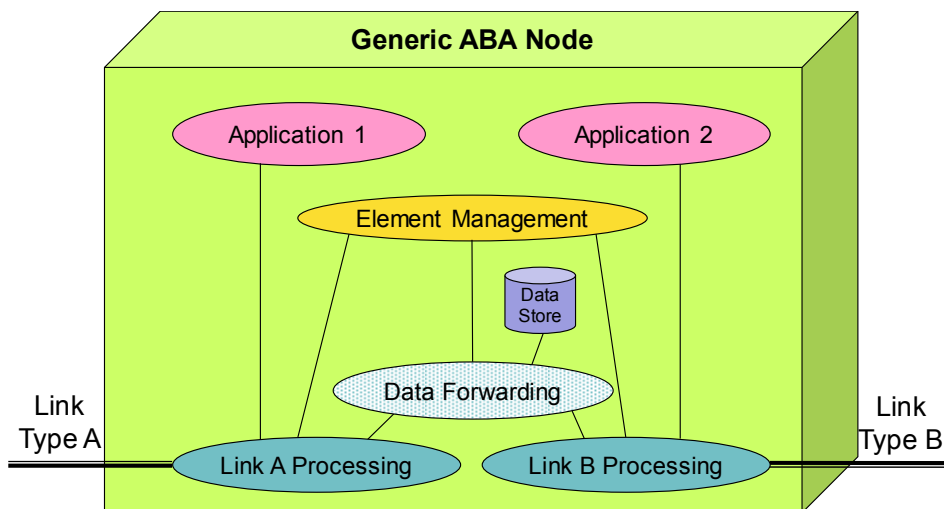

Figure 5-1: ABA Node—Generic Building Block

5.2.1.2 ABA-Specific CSSE Building Blocks

Table 5-1 shows the ABA CSSE node type, its interfaces, and associated functions. The grayed-out functions are not required for ABA, but may be present. This table provides an overview of the ABA CSSE node, the kinds of interfaces it supports (links), and the key functions it implements (link control). For ABA configurations there is only one CSSE type.

Table 5-1: ABA CSSE Node Type, Interfaces, and Functions

CSSE/ Building Block	Terrestrial Links	Space Links	Proximity Links	Space Link Control	Routing
ABA ESLT	X	X		X	N/A

The ABA ESLT node shown in table 5-1 only communicates at the link layer; it does not include any Network Layer routing functions. These nodes can communicate directly to space UEs using standard link layer services and to Earth UEs using terrestrial services (SLE, CSTS, and service management).

5.2.2 ABA-SPECIFIC CSSE BUILDING-BLOCK REQUIREMENTS

5.2.2.1 ABA Current

5.2.2.1.1 ABA ESLT PM shall use CCSDS-compliant user credentials to control access to all service-provider functions (reference [7]).

5.2.2.1.2 ABA ESLT PM shall implement a CCSDS-compliant ABA bilateral service management agreements to permit space-link sessions to be planned, scheduled, requested, and controlled by the Earth User MOC.

5.2.2.1.3 ABA ESLT PM shall process bilateral service management agreements into internal forms useful for system configuration, monitor, and control.

5.2.2.1.4 ABA ESLT PM shall verify requested bilateral service management agreements against those that were planned and scheduled.

NOTE – Unplanned/emergency use of the networks may be required, and in those cases there may not be the possibility of preplanned configurations and verifying services.

5.2.2.1.5 ABA ESLT PM shall process Earth User Node orbit and trajectory files (references [29], [30]) and create necessary pointing and tracking predicts.

5.2.2.1.6 ABA ESLT PM shall configure service production functions to be consistent with the Earth User MOC requested schedule, services, configurations, and sequence of events.

5.2.2.1.7 ABA ESLTs shall verify that the correct SCID is being used to fill space data link fields (references [9], [20], [31]).

5.2.2.1.8 ABA ESLTs shall implement a CCSDS-compliant forward space-link service production function (references [7] and/or [21], [32]), to process ABA Earth User Node requests.

5.2.2.1.9 ABA ESLTs shall implement a CLTU forwarding function (reference [21]).

CCSDS RECOMMENDED PRACTICE FOR SPACE COMMUNICATIONS CROSS SUPPORT—
ARCHITECTURE REQUIREMENTS DOCUMENT

5.2.2.1.10 ABA Earth ESLT should implement the Operational Control Field (ROCF) extraction function (reference [28]) to forward CLCWs in near real time.

5.2.2.1.11 ABA ESLTs shall implement a forward TC frame processing function including fill bit functions (references [7], [21], [31]).

5.2.2.1.12 ABA ESLTs may implement a CLTU storage function for timed release of off-line service production.

5.2.2.1.13 ABA ESLTs shall implement forward modulation functions (reference [34]).

5.2.2.1.14 ABA ESLTs shall implement an RF space-link production function to radiate data to Space User Nodes (reference [34]).

5.2.2.1.15 ABA ESLTs shall implement a CCSDS-compliant return space-link service production function (reference [22] and/or [23]) to process ABA Earth User Node requests.

5.2.2.1.16 ABA ESLTs shall implement a RF space-link production function to receive data from Space User Nodes (reference [34]).

5.2.2.1.17 ABA ESLTs shall implement return demodulation functions (reference [34]).

5.2.2.1.18 ABA ESLTs shall implement time-of-receipt time stamp functions (references [22], [23], or [35]).

5.2.2.1.19 ABA ESLTs shall implement one or both return AOS or telemetry (TM) frame decoding functions (reference [32]).

5.2.2.1.20 ABA ESLTs shall implement one or both return AOS or TM frame processing functions (references [9], [10], [22]).

5.2.2.1.21 ABA ESLTs shall implement a return VC frame extraction function (references [9], [10], [23], [28]).

5.2.2.1.22 ABA ESLTs shall implement one or both AOS or TM frame storage function (references [22] or [23]) for off-line service production and delivery.

5.2.2.1.23 ABA ESLTs should implement a radiometric and tracking service production function (references [D16], [34]) to process ABA Earth User Node requests.

5.2.2.1.24 ABA ESLTs providing radiometric and tracking services should implement Pseudo-Noise (PN) range sequence generation (reference [36]).

NOTE – Proprietary tone and/or hybrid ranging systems (reference [36]) can be used with spacecraft having a transparent ranging channel.

5.2.2.1.25 ABA ESLTs providing radiometric and tracking services should implement range sequence recovery and Doppler processing (references [34] and/or [36]).

5.2.2.1.26 ABA ESLTs providing radiometric and tracking services should implement spacecraft tracking and tracking data processing functions (references [D16], [34]).

5.2.2.1.27 ABA ESLTs providing radiometric and tracking services should implement data return using the NDM or TDM data formats (references [29], [37]).

5.2.2.1.28 ABA ESLTs may implement a Delta-DOR data processing function (references [24], [34]) to process ABA Earth User Node requests.

NOTE – Correlation of raw D-DOR data may be performed by an ESLT or by the user.

5.2.2.1.29 ABA ESLT implementing Delta-DOR services may have to coordinate use of two or more ESLTs which may be from different agencies (reference [24]).

5.2.2.1.30 ABA ESLTs may implement a DOR tone reception function (reference [34]) to receive ABA Space User Node data.

5.2.2.1.31 ABA ESLTs providing Delta-DOR services should implement a Delta-DOR control function (reference [24]).

5.2.2.1.32 ABA ESLTs providing Delta-DOR services should implement Delta-DOR Raw Data Exchange Format (RDEF) raw data file exchange with other service providers or users (reference [38]).

5.2.2.1.33 ABA ESLTs providing Delta-DOR services should implement Delta-DOR processed data return using the NDM or TDM data formats (references [29], [37]).

NOTE – Processing of D-DOR raw data may be performed by one of the service providers, or by the user, or by another entity on the user's behalf.

5.2.2.2 ABA Future

5.2.2.2.1 [Opt][Future] ABA ESLTs may implement one or both forward AOS or TC frame encoding and synchronization functions (references [7], [9], [16], [D14], [31]).

5.2.2.2.2 [Future] ABA ESLTs may implement the CCSDS CSTS F-Frame processing functions (reference [D14]) to support ABA and future SSI services, including frame multiplexing and merging from multiple sources.

5.2.2.2.3 [Future] ABA ESLTs may implement a forward AOS or TC frame merge function (references [7], [D14], [32]).

5.2.2.2.4 [Future] ABA ESLT implementing the F-Frame production functions should implement the Communications Operations Procedure (COP) Frame Operation Procedure (FOP) (references [7], [16], [D14], [33]).

CCSDS RECOMMENDED PRACTICE FOR SPACE COMMUNICATIONS CROSS SUPPORT—
ARCHITECTURE REQUIREMENTS DOCUMENT

5.2.2.2.5 [Future] ABA ESLTs may implement one or more high-level application functions such as file transfer or forwarding (reference [D17]).

5.2.2.2.6 [Future] ABA ESLTs providing cross support file transfer should implement forward and return transfer file processing for the CSTS transfer file interface (reference [D17]).

NOTE – This function may include transfer of off-line telemetry, radiometric, Delta-DOR, or CFDP files.

5.2.2.2.7 [Future] ABA ESLTs providing cross support file transfer should implement forward and return CFDP processing of the files transferred over the space link (references [D15], [39]).

5.2.2.2.8 [Future] ABA ESLTs providing CFDP processing should implement F-Frame merging of the encapsulated PDUs on the space link (reference [D14]).

5.2.2.2.9 [Future] ABA ESLTs providing cross support shall implement the ESCCS-SM service user functions (reference [D10]) to plan, schedule, request, and configure new space communications services.

5.2.2.2.10 [Future] ABA ESLTs providing cross support shall implement CCSDS service-provider catalog (reference [D10]) functions to document and characterize available space communications services.

5.2.2.2.11 [Future] ABA ESLTs providing cross support shall implement CCSDS service-agreement functions (reference [D10]) to define and arrange for delivery of space communications services.

5.2.2.2.12 [Future] ABA ESLTs providing cross support shall implement CCSDS spacecraft configuration functions (reference [D10]) to accept descriptions of the communication configurations of user spacecraft and space communications services.

5.2.2.2.13 [Future] ABA Earth User Nodes shall implement CCSDS network schedule functions (reference [D10]) to identify the expected times for scheduled space communications services.

5.2.2.2.14 [Future] ABA ESLTs should implement CCSDS-compliant, user-accessible monitor data functions (references [D18], [D21]).

5.2.2.2.15 [Future] ABA ESLT providing user-accessible monitor data should include identified monitored parameters and notifiable events (references [D18], [D21]).

5.2.2.2.16 [Future] ABA ESLTs providing user-accessible monitor data should offer cyclical reporting, event subscriptions, and queried reports (references [D18], [D21]).

5.2.2.2.17 [Future] ABA ESLTs should implement CCSDS-compliant user-accessible service control functions (references [D19], [D21]).

5.2.2.2.18 [Future] ABA ESLT providing user-accessible service control should include access to identified key service, control, and configuration parameters for user-controllable functional resources (references [D19], [D21]).

5.2.2.2.19 [Future] ABA ESLTs providing cross support services should accept requests and deliver service accountability reports (reference [D10]).

5.2.3 ABA-SPECIFIC USER ELEMENT NODES

5.2.3.1 Overview

This subsection briefly defines the requirements of each specialized ABA UE type. It also defines the functions allocated to each of these nodes, since these functions are what determines their behavior. There are two basic node types identified in table 5-2, Earth User Nodes and Space User Nodes.

Table 5-2: ABA UE Node Types, Interfaces, and Functions

CSSE/ Building Block	Terrestrial Links	Space Links	Proximity Links	Space Link Control	Routing
Earth User Node	X				N/A
Space User Node		X	X		N/A

5.2.3.2 ABA Earth User Node Requirements

5.2.3.2.1 ABA Earth User Node UM shall use CCSDS-compliant user credentials to authenticate access to all service-provider functions (reference [7]).

5.2.3.2.2 ABA Earth User Node UM shall implement a CCSDS-compliant ABA bilateral service management agreements to plan, schedule, request and control ESLT service-provider functions.

5.2.3.2.3 ABA Earth User Node UM shall define contents of bilateral service management agreements to accurately define required system and spacecraft communication configurations and service characteristics.

5.2.3.2.4 ABA Earth User Node UM shall supply Space User Node orbit and trajectory files (references [29], [30]) so that the ESLT can track them.

5.2.3.2.5 ABA Earth User Node UM, when planning spacecraft trajectories and maneuvers, may request information from a suitable source about potential collisions formatted as conjunction data messages (reference [40]).

CCSDS RECOMMENDED PRACTICE FOR SPACE COMMUNICATIONS CROSS SUPPORT—
ARCHITECTURE REQUIREMENTS DOCUMENT

5.2.3.2.6 ABA Earth User Node UM shall request configuration and sequencing of ESLT bilateral service management agreements that are consistent with the required spacecraft communication schedule, services, configurations, and sequence of events.

5.2.3.2.7 ABA Earth User Nodes shall verify that the correct SCID (reference [20]) is being used in forward and return data link fields.

5.2.3.2.8 ABA Earth User Nodes shall implement a CCSDS-compliant forward space-link data production function (reference [21] or [Opt] [D13]).

5.2.3.2.9 [Opt] ABA Earth User Nodes requiring secure commanding should implement a CCSDS-compliant digital signature or encryption function (reference [7]) for data sent on the space link (references [6], [D22]).

5.2.3.2.10 [Opt] ABA Earth User Nodes requiring secure commanding should implement a CCSDS-compliant key management function (reference [D23]) for data sent on the space link.

5.2.3.2.11 ABA Earth User Nodes shall transfer forward CLTUs using one or more CCSDS-compliant ESLT service providers (reference [21]).

5.2.3.2.12 ABA Earth User Nodes shall ensure that the correct SCID is used to construct commands (references [9], [10], [20], [31]).

5.2.3.2.13 ABA Earth User Nodes should implement a TC frame production function (references [9], [21], [31]).

5.2.3.2.14 ABA Earth User Nodes producing CLTUs shall implement a TC frame encoding and synchronization function (references [7], [31]).

5.2.3.2.15 ABA Earth User Nodes producing CLTUs shall implement a CCSDS-compliant CLTU production function including acquisition sequence and idle bits (references [31], [21]).

5.2.3.2.16 ABA Earth User Nodes producing CLTUs and with $BDP < 10^7$ and RTLT less than 1 second, should implement the COP FOP (references [8], [33]).

5.2.3.2.17 ABA Earth User Nodes requiring the COP, and having limited bandwidth to the service-providing ESLT, should implement OCF reception function and the COP to receive CLCWs sent from their ESLT in near real time.

5.2.3.2.18 ABA Earth User Nodes shall implement a return space-link data reception function (references [22] or [23]).

5.2.3.2.19 ABA Earth User Nodes shall implement CCSDS-compliant return AOS or TM frame processing functions (references [9], [10], [22], or [23]).

5.2.3.2.20 [Opt] ABA Earth User Nodes may implement time-of-receipt time stamp processing functions (reference [35]).

5.2.3.2.21 ABA Earth User Nodes may implement a CCSDS-compliant radiometric and tracking data reception function (reference [D16]).

5.2.3.2.22 ABA Earth User Nodes requiring radiometric and tracking services should implement spacecraft tracking and tracking data processing functions (reference [D16]).

5.2.3.2.23 ABA Earth User Nodes requiring tracking and tracking data processing functions should implement processing for the NDM or TDM data formats (references [29], [37]).

5.2.3.2.24 ABA Earth User Nodes requiring high-precision plane-of-sky positions should use Delta-DOR services (reference [24]).

5.2.3.2.25 ABA Earth User Nodes requiring Delta-DOR services must use two or more ESLTs which may be from different agencies (reference [24]).

5.2.3.2.26 ABA Earth User Nodes requiring Delta-DOR services must implement a Delta-DOR control function (reference [24]).

5.2.3.2.27 ABA Earth User Nodes requiring Delta-DOR services and raw data shall implement Delta-DOR RDEF-formatted return data processing (references [29], [37]).

5.2.3.2.28 ABA Earth User Nodes requiring Delta-DOR services should implement Delta-DOR processed data return using the NDM or TDM data formats (references [29], [37]).

5.2.3.2.29 ABA Earth User Nodes may implement upper-layer application functions, such as file (reference [39]), message (reference [41]), or packet processing (reference [42]).

5.2.3.2.30 ABA Earth User Nodes requiring file transfer should implement forward and return CFDP processing of the transferred files (reference [39]).

5.2.3.2.31 ABA Earth User Nodes implementing CFDP processing should implement forward and return frame merging of the encapsulated PDUs on the space link (reference [14], [39], or [42]).

5.2.3.2.32 ABA Earth User Nodes may implement one or more user application functions.

5.2.3.3 Future ABA Earth User Node Requirements

5.2.3.3.1 [Future] ABA Earth User Nodes requiring AOS forward service shall implement a CCSDS-compliant F-Frame space-link data production function (reference [D14]).

NOTE – Current missions requiring forward AOS may use the experimental SLE EF-CLTU (reference [D13]).

5.2.3.3.2 [Future] ABA Earth User Nodes producing frames shall implement a forward AOS frame production function (reference [9], [32]).

CCSDS RECOMMENDED PRACTICE FOR SPACE COMMUNICATIONS CROSS SUPPORT—
ARCHITECTURE REQUIREMENTS DOCUMENT

5.2.3.3.3 [Future] ABA Earth User Nodes shall transfer a forward AOS frame using one or more CCSDS-compliant ESLT service providers (reference [D14]).

5.2.3.3.4 [Future] ABA Earth User Nodes shall implement the ESCCS-SM service-user functions (reference [D10]) to plan, schedule, request, and configure new space communications services.

5.2.3.3.5 [Future] ABA Earth User Nodes shall implement CCSDS service-provider catalog (reference [D10]) functions to discover and characterize available space communications services.

5.2.3.3.6 [Future] ABA Earth User Nodes shall implement CCSDS service-agreement functions (reference [D10]) to define and arrange for delivery of space communications services.

5.2.3.3.7 [Future] ABA Earth User Nodes shall implement CCSDS spacecraft configuration functions (reference [D10]) to provide descriptions of the communication configurations of user spacecraft and space communications services.

5.2.3.3.8 [Future] ABA Earth User Nodes shall implement CCSDS network schedule functions (reference [D10]) to identify the expected times for scheduled space communications services.

5.2.3.3.9 [Future] ABA Earth User Nodes requiring cross support file transfer should implement forward and return transfer file processing for the CSTS transfer file interface (reference [D17]).

NOTE – This function may include transfer of off-line telemetry, radiometric, Delta-DOR, or CFDP files.

5.2.3.3.10 [Future] ABA Earth User Nodes requiring cross support file transfer should implement forward and return CFDP File Transfer processing (reference [D15]) via the transfer file service (reference [D17]) for files transferred over the space link.

5.2.3.3.11 [Future] ABA Earth User Nodes may implement CCSDS-compliant monitor data processing functions (reference [D18]).

5.2.3.3.12 [Future] ABA Earth User Nodes requiring user-accessible monitor data may request identified monitored parameters and notifiable events (references [D18], [D21]).

5.2.3.3.13 [Future] ABA Earth User Nodes requiring user-accessible monitor data may request available cyclical reporting, event subscriptions, and queried reports (references [D18], [D21]).

5.2.3.3.14 [Future] ABA Earth User Nodes should implement CCSDS-compliant service control functions (reference [D19]).

5.2.3.3.15 [Future] ABA Earth User Nodes requiring user-accessible service control may request access to identified key service control and configuration parameters for user controllable functional resources (references [D19], [D21]).

5.2.3.3.16 [Future] ABA Earth User Nodes requiring cross support services should request and acquire service accountability reports (reference [D10]).

5.2.3.4 ABA Space User Node Requirements

5.2.3.4.1 ABA Space User Nodes shall verify that the correct SCID (reference [20]) is being presented in forward and return data link header fields.

5.2.3.4.2 ABA Space User Nodes shall implement one or more RF space-link reception functions to receive data (reference [34]).

5.2.3.4.3 ABA Space User Nodes shall implement one or more CCSDS-compliant forward space-link data reception functions (references [9], [31]).

5.2.3.4.4 ABA Space User Nodes shall implement one or more forward demodulation functions (reference [34]).

5.2.3.4.5 ABA Space User Nodes shall implement one or more forward frame synchronization and decoding functions (references [8], [32]).

5.2.3.4.6 ABA Space User Nodes shall process CLTUs or forward AOS frames received from one or more CCSDS-compliant ESLT service providers (references [9], [31]).

5.2.3.4.7 ABA Space User Nodes shall ensure that the correct SCID was used to construct commands (references [9], [20], [31]).

5.2.3.4.8 ABA Space User Nodes implementing the F-CLTU reception functions should implement the COP Frame Acceptance and Reporting Mechanism (FARM) (references [8], [32], [33]).

NOTE – For Space User Nodes with RTLT greater than one second the COP cannot be used, but the FARM must still be implemented.

5.2.3.4.9 ABA Space User Nodes implementing the FARM should implement the Communications Link Control Word (CLCW) and insert it into the return link (references [9], [10], [33]).

5.2.3.4.10 [Opt] ABA Space User Nodes requiring secure commanding should implement a digital signature or decryption function for data received on the space link (references [6], [7], [D22]).

5.2.3.4.11 [Opt] ABA Space User Nodes requiring secure commanding should implement a key management function for data received on the space link (reference [D23]).

CCSDS RECOMMENDED PRACTICE FOR SPACE COMMUNICATIONS CROSS SUPPORT—
ARCHITECTURE REQUIREMENTS DOCUMENT

5.2.3.4.12 [Future], [Opt] ABA Space User Nodes may implement a time-of-receipt time stamp function (reference [35]).

5.2.3.4.13 ABA Space User Nodes shall implement a return AOS or TM frame processing function (references [9] or [10]).

5.2.3.4.14 ABA Space User Nodes shall send return TM or AOS frames to one or more CCSDS-compliant ESLT service providers (references [9] or [10]).

5.2.3.4.15 [Future], [Opt] ABA Space User Nodes may implement a time-of-transmission time stamp (reference [35]) function.

5.2.3.4.16 ABA Space User Nodes shall implement one or more encoding and synchronization functions (reference [32]).

5.2.3.4.17 ABA Space User Nodes shall implement one or more return modulation functions (reference [34]).

5.2.3.4.18 ABA Space User Nodes shall implement one or more RF space-link production functions to radiate data (reference [34]).

5.2.3.4.19 ABA Space User Nodes may implement a ranging sequence reception function (references [34], [36]).

5.2.3.4.20 ABA Space User Nodes may implement a coherent or noncoherent ranging sequence regeneration function (references [34], [36]).

5.2.3.4.21 ABA Space User Nodes requiring high-precision, plane-of-sky tracking should implement a DOR tones space-link production function (references [24], [34]).

5.2.3.4.22 ABA Space User Nodes may implement upper-layer application functions, such as file (reference [39]), message (reference [41]), or packet (reference [42]) processing.

5.2.3.4.23 ABA Space User Nodes requiring merging of different protocol PDUs on the space link should assign them to separate VCs (references [8], [9], or [10]).

5.2.3.4.24 [Future] ABA Space User Nodes requiring cross support file transfer should implement forward and return CFDP processing of the transferred files (references [14], [39], or [42]).

5.2.3.4.25 [Future] ABA Space User Nodes requiring CFDP processing should implement forward and return frame merging of the encapsulated PDUs on the space link (references [14], [39], or [42]).

5.2.3.4.26 ABA Space User Nodes may implement one or more user application functions.

5.3 SSI PHYSICAL ELEMENTS

5.3.1 OVERVIEW

5.3.1.1 General

This subsection defines the SSI CSSE and UE nodes and the functions they are expected to implement. A generic physical model of an SSI building block is presented in figure 5-2, followed by the requirements on CSSEs and UEs that are used to compose SSI end-to-end systems.

Regardless of the specific details of how they are implemented, all of the core network and link layer functionality (network processing, link layer processing, routing, network management, and EM) shown in this generic SSI building block will be included in every SSI node. SSI end-user nodes, in space or on the ground, will typically have one or more applications, only one link, not do routing to other nodes, will use standard network management for routing table updates, and will use local means to do node management. SSI service-providing building blocks will typically have at least two links (either one terrestrial and one in space or two in space), will use standard network management and EM, and may have specialized local applications. SSI nodes supporting DTN will all include a local data store.

The full suite of SSI physical node types is described in subsection 5.3 of the SCCS-ADD (reference [D5]).

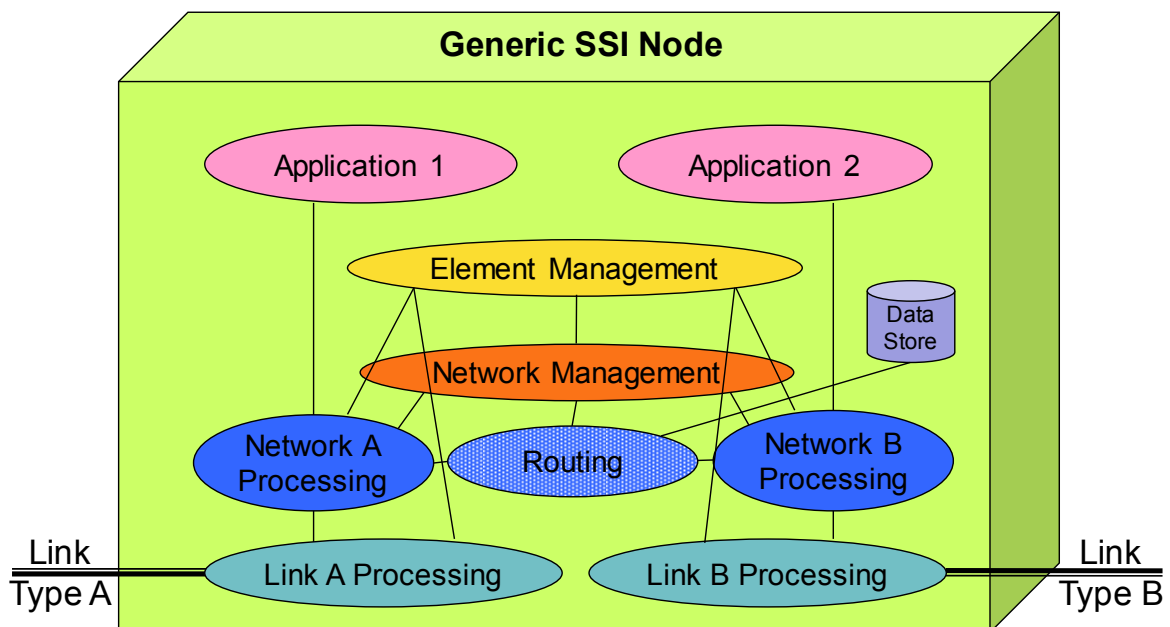

Figure 5-2: SSI Node—Generic Building Block

CCSDS RECOMMENDED PRACTICE FOR SPACE COMMUNICATIONS CROSS SUPPORT—
ARCHITECTURE REQUIREMENTS DOCUMENT

5.3.1.2 SSI-Specific CSSE Building Blocks

The following subsections define the requirements of each specialized SSI CSSE physical node. Each of the building blocks provides a nominal set of interfaces, either over a space link (typically RF) or over some sort of terrestrial link, or both. They also provide required functionality such as

- a) Network Layer processing (routing, forwarding, gateway, and security functions);
- b) store-and-forward (S&F) data handling;
- c) Data Link Layer processing;
- d) RF transmit/receive functions; and
- e) service management, network control, and routing exchange/peering functions.

They may also implement last-hop essential commanding and emergency mode functions and first-hop data return functions.

Table 5-3 provides an overview of the SSI CSSE node types, their interfaces, and their functions. Not all nodes will necessarily support all functions and interfaces, but each SSI building block will at least support DTN or IP (or both) Network Layer functions as well as the Data Link Layer and lower functions.

Table 5-3: SSI CSSE Node Types, Interfaces, and Functions

CSSE/Building Block	Terrestrial Links	Space Links	Proximity Links	Space Link Control	Routing
ESLT	X	X		X	X
Earth Routing Node	X			X	X
Space Routing Node		X	X	X	X
PSLT		X	X	X	X
Earth WAN Routing Node	X				X
Planet WAN Routing Node	X				X
Hybrid Science/Routing Node	X	X	X	Varies	X

The Hybrid Science/Routing Node (HSRN) shown in table 5-3 operates as does a Space Routing Node (see 5.3.7). The difference is that the HSRN will usually have science requirements that are paramount during the prime mission phase.

5.3.2 SSI PHYSICAL ELEMENT REQUIREMENTS

5.3.2.1 Future SSI Earth-Space Link Terminal Requirements

5.3.2.1.1 [Future] SSI ESLT nodes shall implement all of the functions required of ABA ESLT nodes, as defined in 5.2.

- 5.3.2.1.2** [Future] SSI ESLT nodes shall provide SSI Stage 2 and 3 services for users (reference [D7]).
- 5.3.2.1.3** [Future] SSI ESLT nodes shall implement one or more CCSDS-compliant space internetworking functions (reference [DTN] or [IPS]) to process, store, and route DTN or IP data in the ground station.
- 5.3.2.1.4** [Future] SSI ESLTs implementing DTN should acquire DTN endpoint addresses using the SANA registries (reference [19]) for BP and LTP identifiers.
- 5.3.2.1.5** [Future] SSI ESLTs implementing IP should acquire IP endpoint addresses and identifiers using the Internet Assigned Numbers Authority (IANA) registries for IP and DNS identifiers.
- 5.3.2.1.6** [Future] SSI ESLT nodes shall implement SSI NSAs, coordination, peering, and network management functions in the ground station (reference [D7]).
- 5.3.2.1.7** [Future] SSI ESLT nodes shall implement the CCSDS CSTS F-Frame processing functions (reference [D14]) to support internetworking and ABA services, including frame multiplexing and merging from multiple sources.
- 5.3.2.1.8** [Future] SSI ESLT nodes shall implement the CCSDS CSTS F-Frame-compliant functions (reference [D14]), including fill-frame or fill-data insertion, to maintain link synchrony.
- 5.3.2.1.9** [Future] SSI ESLT nodes shall implement CCSDS-compliant LTP processing (reference [13]) in the ground station.
- 5.3.2.1.10** [Future] SSI ESLT nodes shall implement CCSDS-compliant LTP PDU, DTN or IP encapsulation (references [9], [10], [14], [31], [46]) in the ground station.
- 5.3.2.1.11** [Future] SSI ESLT nodes shall implement all of the CCSDS-compliant space link PDU processing, TC, TM, or AOS (references [9], [10], [31]) in the ground station.
- 5.3.2.1.12** [Future] SSI ESLT nodes shall implement CCSDS-compliant frame encoding in the ground station (references [8], [32]).
- 5.3.2.1.13** [Future] SSI ESLT nodes shall implement the extended CCSDS service-management functions (reference [D10]) to plan, schedule, request, configure, and control the SSI ESLT services.
- 5.3.2.1.14** [Future] SSI ESLT nodes shall implement the DTN network-management functions (reference [D7]) to plan, schedule, coordinate, configure, and manage the SSI ESLT services.

CCSDS RECOMMENDED PRACTICE FOR SPACE COMMUNICATIONS CROSS SUPPORT—
ARCHITECTURE REQUIREMENTS DOCUMENT

5.3.2.2 Future SSI Earth Routing Node Requirements

5.3.2.2.1 [Future] SSI Earth routing nodes (SSI space routing node MOC) shall implement all of the functions required of ABA Earth User Node nodes, as defined in 5.2.2.2.5.

5.3.2.2.2 [Future] SSI Earth routing nodes (SSI space routing node MOC) may implement one or more CCSDS-compliant space internetworking functions, to process IP or DTN data (reference [IPS] or [DTN]).

5.3.2.2.3 [Future] SSI Earth routing nodes implementing DTN should acquire DTN endpoint addresses using the SANA registries (reference [19]) for BP and LTP identifiers.

5.3.2.2.4 [Future] SSI Earth routing nodes implementing IP should acquire IP endpoint addresses and identifiers using the IANA registries for IP and DNS identifiers.

5.3.2.2.5 [Future] SSI Earth routing nodes (SSI space routing node MOC) shall implement SSI NSAs, coordination, peering, and network management functions (reference [D7]).

5.3.2.2.6 [Future] SSI Earth routing nodes (SSI space routing node MOC) shall operate a space relay asset to provide SSI Stage 2 and 3 services for users (reference [D7]).

5.3.2.2.7 [Future] SSI Earth routing nodes (SSI space routing node MOC) shall implement all of the functions required to operate a space relay asset (space routing node or PSLT) (reference [D7]).

5.3.2.2.8 [Future] SSI Earth routing nodes (SSI space routing node MOC) should implement one or more CCSDS-compliant space link PDU processing functions, for TC, TM, or AOS, (references [9], [10], or [31]) to perform basic spacecraft Telemetry, Tracking & Command (TT&C) functions for the space relay asset they operate.

5.3.2.2.9 [Future] SSI Earth routing nodes (SSI space routing node MOC) must implement one or more CCSDS-compliant internetworking management functions (references [D12], [27]) to control the space relay asset.

5.3.2.2.10 [Future] SSI Earth routing nodes (SSI space routing node MOC) may implement upper-layer application functions for processing files, frames, messages, or packets.

5.3.2.2.11 [Future] SSI Earth routing nodes (SSI space routing node MOC) may provide SSI routing functions as a service for other SSI Earth User Nodes (reference [D7]).

5.3.2.2.12 [Future] SSI Earth routing nodes (SSI space routing node MOC) nodes shall implement the extended CCSDS service-management functions (reference [D10]) to plan, schedule, request, configure and control the SSI ESLT service provider.

5.3.2.3 Future SSI Space Routing Node Requirements

5.3.2.3.1 [Future] SSI space routing nodes shall implement all of the functions required of ABA Space User Nodes, as defined in 5.2.2.2.5.

5.3.2.3.2 [Future] SSI space routing nodes shall operate as a space relay asset to provide SSI Stage 2 and 3 services for users (reference [D7]).

5.3.2.3.3 [Future] SSI space routing nodes shall implement one or more CCSDS-compliant space internetworking functions (reference [DTN] or [IPS]), to process, store, manage, and route DTN or IP data, in the relay asset.

5.3.2.3.4 [Future] SSI space routing nodes with intermittent link connectivity, BDP $>10^7$, or long RTLTs (>2 seconds) should implement the DTN internetworking functions (reference [DTN]).

5.3.2.3.5 [Future] SSI space routing nodes implementing DTN should acquire DTN endpoint addresses using the SANA registries (reference [19]) for BP and LTP identifiers.

5.3.2.3.6 [Future] SSI space routing nodes with continuous link connectivity, BDP $<10^7$ and short RTLTs may implement the basic IP internetworking functions (reference [IPS]).

5.3.2.3.7 [Future] SSI space routing nodes implementing IP should acquire IP endpoint addresses and identifiers using the IANA registries for IP and DNS identifiers.

5.3.2.3.8 [Future] SSI space routing nodes shall implement SSI NSAs, coordination, peering, and network management functions (reference [D7]).

5.3.2.3.9 [Future] SSI space routing nodes must implement one or more CCSDS-compliant internetworking management functions (reference [D12], [27]) to control the space relay asset.

5.3.2.3.10 [Future] SSI space routing nodes shall implement one or more CCSDS-compliant space-link PDU processing functions, for Proximity-1, TC, TM, or AOS, (references [9], [10], [31], [43], [44], or [45]) in the relay asset.

5.3.2.3.11 [Future] SSI space routing nodes must implement protocol and PDU conversion and bridging functions in the relay asset (references [D7], [D24]).

5.3.2.3.12 [Future] SSI space routing nodes should implement CCSDS-compliant last-hop or first-hop functions (reference [D20]) to reboot SSI nodes and serve non-SSI and other end-user nodes.

5.3.2.3.13 [Future] Space routing nodes may implement CCSDS-compliant radiometric tracking data recovery functions (reference [D20]) for the proximity link.

5.3.2.3.14 [Future] SSI space routing nodes may implement CCSDS-compliant proximity link time-stamp functions (reference [D20]).

CCSDS RECOMMENDED PRACTICE FOR SPACE COMMUNICATIONS CROSS SUPPORT—
ARCHITECTURE REQUIREMENTS DOCUMENT

5.3.2.3.15 [Future] SSI space routing nodes may implement proximity link open-loop recording and data return functions (reference [D20]).

5.3.3 SSI PLANET-SPACE LINK TERMINAL

5.3.3.1 Overview

A PSLT is essentially the same as an ESLT, but it is located on the surface of some remote planetary body and provides the space link over which BP and IP traffic is routed between a planetary WAN and any other nearby or distant space or landed SSI nodes.

A PSLT provides many of the same functions as the ESLT, in that it 1) encapsulates and multiplexes BP bundles and/or IP datagrams destined for space into a symbol stream that is modulated to RF and radiated toward the next Space User Node in the SSI, and 2) receives and demodulates RF signals from Space User Nodes and de-multiplexes and de-encapsulates IP datagrams and BP bundles destined for terrestrial SSI nodes. In those cases where a single PSLT maintains multiple concurrent space links to different destinations, it will also perform a routing function to place the datagrams/bundles on the appropriate space links; it may also do routing to one or more planetary WAN links. It may also provide SLE/CSTS services to local users and Network Layer security services. In the case of BP, the PSLT will also act as an intermediary storage point for bundles and may assume custody of bundles, as controlled by the relevant SLAs in force.

A PSLT may establish and maintain space links with some or all of the following:

- a) space routing nodes (using proximity protocols or AOS/TC/TM);
- b) ESLTs (using AOS/TC/TM);
- c) other user nodes on the surface of the planet (using BP or IP over ‘terrestrial’ links deployed on the planet); or
- d) directly with Space User Nodes on mission spacecraft.

A PSLT could also offer SLE/CSTS service interfaces to ‘local’ users on a remote planet who manage nearby SSI (or ABA) space routing nodes.

5.3.3.2 Future SSI Planet-Space Link Terminal Requirements

5.3.3.2.1 [Future] SSI PSLT nodes shall implement all of the functions required of SSI space routing nodes, as defined in 5.3.2.3.

5.3.3.2.2 [Future] SSI PSLT nodes shall operate as a space relay asset to provide SSI Stage 2 and 3 services for users (reference [D7]).

- 5.3.3.2.3** [Future] SSI PSLT nodes shall implement one or more CCSDS-compliant space internetworking functions (reference [IPS] or [DTN]) to process, store, and route IP or DTN data in the space link terminal.
- 5.3.3.2.4** [Future] SSI PSLT nodes shall implement SSI NSAs, coordination, peering, and network management functions (reference [D7]).
- 5.3.3.2.5** [Future] SSI PSLT nodes must implement one or more CCSDS-compliant internetworking management functions (references [D12], [27]) to control the space relay asset.
- 5.3.3.2.6** [Future] SSI PSLT nodes shall implement frame processing functions to support internetworking and ABA services, including frame multiplexing and merging from multiple sources (To Be Determined [TBD]).
- 5.3.3.2.7** [Future] SSI PSLT nodes shall implement frame processing functions, including fill-frame or fill-data insertion to maintain link synchrony (TBD).
- 5.3.3.2.8** [Future] SSI PSLT nodes shall implement CCSDS-compliant LTP processing (reference [13]) in the space link terminal.
- 5.3.3.2.9** SSI PSLT nodes shall implement CCSDS-compliant LTP PDU, DTN or IP encapsulation (references [9], [10], [14], [31], [46]) in the space link terminal.
- 5.3.3.2.10** SSI PSLT nodes shall implement all of the CCSDS-compliant space link PDU processing and frame creation, for AOS, TM, TC, or Proximity-1, (references [9], [10], [31], [43], [44], [45]) in the space link terminal.
- 5.3.3.2.11** [Future] SSI PSLT nodes shall implement CCSDS-compliant frame merging in the space link terminal (reference [9], [10], [31]).
- 5.3.3.2.12** [Future] SSI PSLT nodes shall implement CCSDS-compliant frame decoding in the space link terminal (reference [8], [32]).
- 5.3.3.2.13** [Future] SSI PSLT nodes shall implement CCSDS-compliant frame encoding in the space link terminal (reference [8], [32]).
- 5.3.3.2.14** [Future] SSI PSLT shall implement protocol and PDU conversion and bridging functions in the relay asset (reference [D7], [D24]).
- 5.3.3.2.15** [Future] SSI PSLT should implement CCSDS-compliant last-hop or first-hop functions (reference [D20]) to reboot SSI nodes and serve non-SSI and other end-user nodes.
- 5.3.3.2.16** [Future] SSI PSLT may implement CCSDS-compliant radiometric tracking data recovery functions (reference [D20]) for the proximity link.
- 5.3.3.2.17** [Future] SSI PSLT may implement CCSDS-compliant proximity link time-stamp functions (reference [D20]).

CCSDS RECOMMENDED PRACTICE FOR SPACE COMMUNICATIONS CROSS SUPPORT—
ARCHITECTURE REQUIREMENTS DOCUMENT

5.3.3.2.18 [Future] SSI PSLT may implement proximity link open-loop recording and data return functions (reference [D20]).

5.3.3.2.19 [Future] SSI PSLT nodes shall implement the extended CCSDS service-management functions (reference [D10]) to plan, schedule, request, configure and control the SSI PSLT service provider.

5.3.3.3 SSI Earth/Planet WAN Routing Node

5.3.3.3.1 Overview

An SSI Earth WAN consists of one or more routing nodes that provide Network Layer connectivity among terrestrial SSI user nodes and ESLTs. In addition to the transport of 'data', the WAN may be used to transport voice and video, which can require specialized handling because of latency and jitter considerations. The WAN provides the connectivity over which DTN bundles/IP packets are exchanged among terrestrial nodes and ESLTs. Routing nodes in a BP-enabled WAN also typically will contain a data store, but this is not always required.

An SSI planet WAN is essentially the same as an SSI Earth WAN—i.e., it provides Network Layer connectivity among SSI user nodes and PSLTs located on other planetary bodies. In addition to the transport of data, the WAN may be used to transport voice and video (e.g., Voice Over Internet Protocol [VOIP]). Planet WANs may use either IP or BP as the basis for their Network Layer connectivity.

5.3.3.3.2 Future SSI Earth/Planet WAN Routing Node Requirements

5.3.3.3.2.1 [Future] SSI Earth/planet WAN routing nodes shall operate as routing and relay assets to provide SSI Stage 2 and 3 services for users (reference [D7]).

5.3.3.3.2.2 [Future] SSI Earth/planet WAN routing nodes shall implement one or more CCSDS-compliant space internetworking functions (reference [IPS] or [DTN]) to process, store, and route IP or DTN data in the routing node.

5.3.3.3.2.3 [Future] SSI Earth/planet WAN routing nodes serving user missions with intermittent link connectivity, $BDP > 10^7$, or long RTLs (> 2 seconds) should implement the DTN internetworking functions.

5.3.3.3.2.4 [Future] SSI Earth/planet WAN routing nodes implementing DTN should acquire DTN endpoint addresses using the SANA registries (reference [19]) for BP and LTP identifiers.

5.3.3.3.2.5 SSI Earth/planet WAN routing nodes serving user missions with continuous link connectivity, $BDP < 10^7$, and short RTLs may implement the basic IP internetworking functions (reference [IPS]).

5.3.3.3.2.6 [Future] SSI Earth/planet WAN routing nodes implementing IP should acquire IP endpoint addresses and identifiers using the IANA registries for IP and DNS identifiers.

5.3.3.3.2.7 [Future] SSI Earth/planet WAN routing nodes shall implement SSI NSAs, coordination, peering, and network management functions (reference [D7]).

5.3.3.3.2.8 [Future] SSI Earth/planet WAN routing nodes must implement one or more CCSDS-compliant internetworking management functions (references [D12], [27]) to control the routing node.

5.3.3.3.2.9 [Future] SSI Earth/planet WAN routing nodes shall implement one or more appropriate terrestrial link layer functions in the routing node, i.e., Ethernet, WiFi, serial link, or other.

5.3.3.3.2.10 [Future] SSI Earth/planet WAN routing nodes must implement protocol and PDU conversion and bridging functions in the routing node (reference [D24]).

5.3.4 DISCUSSION

5.3.4.1 SSI-Specific User Node Types

The following subsections briefly define the specialized SSI UE physical nodes and their roles. Each of these UEs provides a nominal set of interfaces, either over a space link (typically RF) or over some sort of terrestrial link, or both. They also provide required functionality such as

- a) Network Layer processing (routing, forwarding, security, and gateway functions);
- b) S&F data handling;
- c) Data Link Layer processing; and
- d) RF transmit/receive functions.

Table 5-4 provides an overview of the specific SSI UE node types, their interfaces, and their functions.

Table 5-4: SSI UE Node Types, Interfaces, and Functions

UE	Terrestrial Links	Space Links	Proximity Links	Space Link Control	Routing
Earth User Node	X				X
Space/Planet User Node			X		X
Hybrid Science/Routing Node		X	X	Varies	X

CCSDS RECOMMENDED PRACTICE FOR SPACE COMMUNICATIONS CROSS SUPPORT—
ARCHITECTURE REQUIREMENTS DOCUMENT

5.3.4.2 User Node Operation

User nodes that participate fully in the SSI must directly implement a completely functional version of the Network Layer protocols, but will not necessarily provide either the resources or the full functions for forwarding, security, and management to provide services to other nodes. These nodes must, however, implement enough of the routing functionality to be able to identify and route to the next hop node that does provide full SSI services.

Any end-user node that does implement routing and forwarding, in addition to other typical user/science functions, could function as a hybrid science/routing node. As such, these hybrid nodes perform both as SSI user nodes and as SSI CSSEs.

Any Stage 1 SSI UE node may deploy and use SSI services, but in Stage 1 there is no expectation that SSI ESLTs or WAN nodes, with full routing and other services, will be available. In Stage 1 SSI UEs must perform any and all SSI functions and will utilize ABA ESLTs to only provide space link access and normal link layer services. All SSI functionality is performed in the user nodes, but these may, by local agreement, provide services to other SSI UEs as well. At the time of publication, Stage 1 SSI services have already been deployed in more than one space environment for demonstration purposes.

5.3.5 SSI EARTH USER NODE

5.3.5.1 Overview

SSI Earth User Nodes use SSI services to communicate with one or more SSI assets located in space. In SSI Stage 1 this will involve use of an ABA ESLT. In Stages 2 and 3 this may involve use of an SSI ESLT or PSLT, Earth routing node, WAN, or other SSI assets.

5.3.5.2 Requirements

5.3.5.2.1 SSI Earth User Nodes shall implement one or more CCSDS-compliant space internetworking functions (reference [IPS] or [DTN]), for IP or DTN processing.

5.3.5.2.2 SSI Earth User Nodes with intermittent link connectivity, $BDP > 10^7$, or long RTLts (> 2 seconds) should implement the basic DTN internetworking functions (reference [DTN]).

5.3.5.2.3 SSI Earth User Nodes implementing DTN should acquire DTN endpoint addresses using the SANA registries (reference [19]) for BP and LTP identifiers.

5.3.5.2.4 SSI Earth User Nodes with continuous link connectivity, $BDP < 10^7$, and short RTLts may implement the basic IP internetworking functions (reference [IPS]).

5.3.5.2.5 SSI Earth User Nodes implementing IP should acquire IP endpoint addresses and identifiers using the IANA registries for IP and DNS identifiers.

5.3.5.2.6 SSI Earth User Nodes may connect directly to an ABA ESLT to access space link services.

5.3.5.2.7 SSI Earth User Nodes connecting directly to an ABA ESLTs shall implement all of the functions required of ABA Earth User Nodes, as defined in 5.2.3.2.

5.3.5.2.8 [Future] SSI Earth User Nodes may connect to an SSI ESLT, SSI Earth routing node, or SSI Earth WAN routing node for SSI routing services.

5.3.5.2.9 [Future] SSI Earth User Nodes connecting directly to an SSI ESLTs shall implement all of the functions required of SSI Earth routing nodes, as defined in 5.3.2.2.

5.3.5.2.10 [Future] SSI Earth User Nodes shall implement SSI NSA and coordination functions (reference [D7]).

5.3.5.2.11 [Future] SSI Earth User Nodes shall implement one or more appropriate terrestrial link layer functions to connect to the SSI routing node, i.e., Ethernet, WiFi, serial link, or other.

5.3.5.2.12 [Future], [Opt] SSI Earth User Nodes requiring secure or authenticated communications should implement one or more of the CCSDS security functions (reference [6]) to secure the data payload.

5.3.5.2.13 [Future], [Opt] SSI Earth User Nodes requiring secure commanding may implement a digital signature or encryption function for data received on the space link (references [6], [7], [D22]).

5.3.5.2.14 [Future], [Opt] SSI Earth User Nodes requiring secure commanding should implement a key management function for data sent on the space link (reference [D23]).

5.3.5.2.15 [Future], [Opt] SSI Earth User Nodes implementing DTN and requiring secure or authenticated network communications may implement the SBSP (references [D26], [D24]) to secure the end-to-end network communications.

5.3.5.2.16 SSI Earth User Nodes may implement upper-layer application functions, for processing files, frames, messages, or packets.

5.3.6 SSI SPACE/PLANET USER NODE

5.3.6.1 Overview

SSI Space/planet User Nodes use SSI services to communicate with their SSI Earth User Node or with one or more other SSI assets located in space. In SSI Stage 1 this will involve use of an ABA ESLT. In Stages 2 and 3 this may involve use of an SSI ESLT or PSLT, Earth routing node, WAN, or other SSI assets.

CCSDS RECOMMENDED PRACTICE FOR SPACE COMMUNICATIONS CROSS SUPPORT—
ARCHITECTURE REQUIREMENTS DOCUMENT

5.3.6.2 Requirements

5.3.6.2.1 SSI Space User Nodes shall implement all of the functions required of ABA Space User Nodes, as defined in 5.2.3.3.

5.3.6.2.2 SSI Space User Nodes shall implement one or more CCSDS-compliant space internetworking functions (reference [IPS] or [DTN]), to process, store, manage, and route IP or DTN data, in the relay asset.

5.3.6.2.3 SSI Space User Nodes with intermittent link connectivity, $BDP > 10^7$, or long RTLTs (> 2 seconds) should implement the DTN internetworking functions.

5.3.6.2.4 SSI Space User Nodes implementing DTN should acquire DTN endpoint addresses using the SANA registries (reference [19]) for BP and LTP identifiers.

5.3.6.2.5 SSI Space User Nodes with continuous link connectivity, $BDP < 10^7$, and short RTLTs may implement the basic IP internetworking functions (reference [IPS]).

5.3.6.2.6 SSI Space User Nodes implementing IP should acquire IP endpoint addresses and identifiers using the IANA registries for IP and DNS identifiers.

5.3.6.2.7 [Future] SSI Space User Nodes may connect to an SSI ESLT or PSLT, SSI space routing node, or SSI Planet WAN routing node for SSI routing services.

5.3.6.2.8 [Future] SSI Space User Nodes connecting over a space link shall implement one or more CCSDS-compliant space-link PDU processing functions, for AOS, TM, TC, or Proximity-1 (references [9], [10], [31], or [43], [44], [45]) in the user node.

5.3.6.2.9 [Future] SSI Space User Nodes connecting over a space link may implement CCSDS-compliant frame merging in the user node.

5.3.6.2.10 [Future] SSI Space User Nodes connecting over a space link shall implement CCSDS-compliant frame decoding in the user node (references [8], [16]).

5.3.6.2.11 [Future] SSI Space User Nodes connecting over a space link shall implement CCSDS-compliant frame encoding in the user node (references [8], [16]).

5.3.6.2.12 [Future] SSI Space User Nodes connecting over a terrestrial link may implement one or more appropriate terrestrial link layer functions to connect to the SSI routing node, i.e., Ethernet, WiFi, serial link, or other.

5.3.6.2.13 [Future] SSI Space User Nodes may implement one or more CCSDS-compliant internetworking management functions (reference [D12]) to control the Space User Node.

5.3.6.2.14 [Future], [Opt] SSI Space User Nodes requiring secure or authenticated communications should implement one or more of the CCSDS security functions (reference [6]) to secure the data payload.

5.3.6.2.15 [Future], [Opt] SSI Space User Nodes requiring secure commanding may implement a digital signature or decryption function for data received on the space link (references [6], [7], [D22]).

5.3.6.2.16 [Future], [Opt] SSI Space User Nodes requiring secure commanding should implement a key management function for data sent on the space link (reference [D23]).

5.3.6.2.17 [Future], [Opt] SSI Space User Nodes implementing DTN and requiring secure or authenticated network communications may implement the SBSP (references [D26], [D24]) to secure the end-to-end network communications.

5.3.6.2.18 SSI Space User Nodes may implement upper-layer application functions, for processing files, frames, messages, or packets.

5.3.7 SSI HYBRID/SCIENCE ROUTING NODE

5.3.7.1 Overview

SSI hybrid/science routing nodes are primarily science/user nodes, but they may also provide SSI services to one or more SSI assets located in space. In SSI Stage 1 these nodes will probably involve use of an ABA ESLT and an SSI Earth User Node that may also act as an Earth routing node. In SSI Stage 2 or 3 these hybrid nodes are likely to provide important ‘building blocks’ toward a widely available SSI infrastructure.

5.3.7.2 Requirements

5.3.7.2.1 SSI hybrid/science routing nodes will implement all required science/exploration functions required by their primary mission.

5.3.7.2.2 SSI hybrid/science routing nodes shall implement all of the functions required of ABA Space User Nodes, as defined in 5.2.3.4.

5.3.7.2.3 SSI hybrid/science routing nodes must implement the essential SSI space routing node service functions as defined in 5.3.2.3.

5.3.7.2.4 SSI hybrid/science routing nodes may implement all of the functions required of SSI Space User Nodes, as defined in 5.3.6.

5.4 SECURITY REQUIREMENTS FOR PHYSICAL ELEMENTS

5.4.1 OVERVIEW

The system elements that provide user services typically will be secured physically. The following physical security methods are likely to be employed at service system boundaries for manned or unmanned elements located on Earth, on other planetary surfaces, or in space.

CCSDS RECOMMENDED PRACTICE FOR SPACE COMMUNICATIONS CROSS SUPPORT—
ARCHITECTURE REQUIREMENTS DOCUMENT

The security documents (references [6], [D25]) provide for more details about security and threat analysis. Management access to elements located in space typically will be secured by various encryption algorithms and protocols that will be described in more detail in section 6.

5.4.2 REQUIREMENTS

5.4.2.1 All Earth-based or planet surface operational systems should be within a secure physical perimeter (references [6], [D25]).

5.4.2.2 Only vetted, approved, and trained staff should be allowed physical access to operational systems.

5.4.2.3 Appropriate credentials should be required to gain physical access to operational facilities.

5.4.2.4 Isolated LANs and firewalls should be used to secure the operational systems.

5.4.2.5 Operational systems may be configured to be accessible only via proxy agents or a 'demilitarized zone' (DMZ).

6 COMMUNICATIONS VIEW

6.1 OVERVIEW

6.1.1 GENERAL

This view focuses on the communications protocols used for accessing SCCS services that are provided by CSSSEs and CSSEs. Its focus is on the details of the communications protocol stacks that define the technical characteristics of the interface binding points between the CSSEs and UEs.

The communications protocols used for accessing a SCCS service are determined by the nature of the cross support service, the kinds of interface binding points that are supported, and where the service elements are located. For example, for an ABA space link service that delivers telemetry frames from a Space User Node to an Earth User Node using an ESLT, the CCSDS TM or AOS Space Data Link Protocol (references [9] or [10]), appropriate coding and one of the CCSDS RF and modulation recommendations (reference [34]) will be used on the space interface of the Space User Node and the ESLT. The terrestrial interface that delivers those frames to the Earth User Node will use SLE or CSTS and terrestrial link protocols, and data may flow over a WAN. Because of these different interfaces, the appropriate sets of communications protocols must be specified for each interface of each CSSE.

This section does not attempt to provide concrete guidance for the selection of specific modulation, coding, or link layer standards for any particular application. That is a deep technical subject that requires careful analysis of mission and communications asset characteristics and mission trajectory. Various network service providers offer systems-engineering support, user guides and link design handbooks that should be consulted for technical specifics relevant for any given mission. There are also CCSDS documents that provide excellent overviews of these topics. The reader is directed to the Overview of Space Communications Protocols (OSCP) (reference [D8]), TC (and TM) Synchronization and Channel Coding (references [8], [32]), Bandwidth-Efficient Modulations (reference [34]) and the other technical standards to which they refer.

6.1.2 SPECIFIC PROTOCOLS FOR SERVICE INTERFACE BINDING

6.1.2.1 General

Each cross support service uses a set of communications protocols that is determined by the nature of the service, the locations of the physical elements (the CSSE and the Earth and Space User Nodes), and the characteristics of the physical links between the physical elements.

CCSDS RECOMMENDED PRACTICE FOR SPACE COMMUNICATIONS CROSS SUPPORT—
ARCHITECTURE REQUIREMENTS DOCUMENT**6.1.2.2 Referenced Communication Protocols**

Table 6-1 lists the common communications protocols used to support SCCS services that are referenced in this document. Terrestrial CSSSEs and CSSEs may use other commercial communications protocols that are not listed in this table.

The ABA link layer configurations use only the first three sections of table 6-1; the SSI configurations use one or both of the last two sections along with the Physical Layer through Data Link Layer protocols specified in the first three sections of the table. For ABA configurations, any mission Application Layer protocols are usually implemented directly on the Data Link Layer, using a ‘shim’ such as Space Packet Protocol (SPP) (reference [42]) or Encapsulation Packet (EP) described in the Encapsulation Service (reference [14]). For the SSI, any mission Application Layer protocols will be implemented on top of the Network Layer protocols instead of directly on the Data Link Layer protocols and these also use the Encapsulation Service.

Table 6-1: Referenced Communications Protocols

Comm Link Type	Communications Protocol	Reference
ABA and SSI		
Proximity Links	Proximity-1 Space Link Protocols: Data Link Layer	CCSDS 211.0-B.5 [43]
	Proximity-1 Space Link Protocols: Physical Layer	CCSDS 211.1-B.4 [44]
	Proximity-1 Space Link Protocols: Coding and Synchronization Sublayer	CCSDS 211.2-B.2 [45]
Space-to-Ground Links	Radio Frequency and Modulation Systems—Part 1: Earth Stations and Spacecraft (RF, modulation, ranging, DOR tones)	CCSDS 401.0-B.23 [34]
	Pseudo-Noise (PN) Ranging Systems	CCSDS 414.1-B-2 [36]
	TC Synchronization and Channel Coding	CCSDS 231.0-B.2 [8]
	TM Synchronization and Channel Coding	CCSDS 131.0-B.2 [32]
	TC Space Data Link Protocol	CCSDS 232.0-B.2 [31]
	TM Space Data Link Protocol	CCSDS 132.0-B.1 [10]
	AOS Space Data Link Protocol	CCSDS 732.0-B.2 [9]
	Communications Operation Procedure-1 (COP-1)	CCSDS 232.1-B-2 [33]
	Flexible Advanced Coding and Modulation Scheme for High Rate Telemetry Applications	CCSDS 131.2-B-1 [56]
	CCSDS Space Link Protocols Over ETSI DVB-S2 Standard	CCSDS 131.3-B-1 [57]
Application Layer Protocols	Space Packet Protocol	CCSDS 133.0-B.1 [42]
	Encapsulation Service	CCSDS 133.1-B-2 [14]
	CCSDS File Delivery Protocol	CCSDS 727.0-B.4 [39]
	Asynchronous Message Service (AMS)	CCSDS 735.1-B-1 [41]

Comm Link Type	Communications Protocol	Reference
	Global Spacecraft Identification Field Code Assignment Control Procedures	CCSDS 320.0-B-6 [20]
	Space Assigned Numbers Authority (SANA)—Role, Responsibilities, Policies, and Procedures	CCSDS 313.0-Y-1 [18]
	Time Code Formats	CCSDS 301.0-B-4 [35]
SSI Only		
DTN Internetworking Protocols	Bundle Protocol Specification	RFC 5050 [12]
	CCSDS Bundle Protocol Specification	CCSDS 734.2-R Draft [D24]
	Licklider Transmission Protocol—Specification	RFC 5326 [13]
	Contact Graph Routing Protocol	Burleigh, December 2009 [D11]; work in progress
	Last-Hop/First-Hop Service	CCSDS White Paper [D20]
	Delay Tolerant Network Management Protocol	Birrane/Ramachandran, July 2012 [D12]; work in progress
IP Internetworking Protocols	Internet Protocol	STD 5 [47]
	IP over CCSDS Space Links	CCSDS 702.1-B-1 [46]
	Transmission Control Protocol	STD 7 [48]
	User Datagram Protocol	STD 6 [49]
	File Transfer Protocol (FTP)	STD 9 [25]
	Hypertext Transfer Protocol—HTTP/1.1	RFC 2068 [50]
	Internet Control Message Protocol (ICMP)	STD 5 [27]
	IP Header Compression	RFC 2507 [51]

In alignment with the OSI Basic Reference Model (reference [4]) CCSDS normally defines its standards to align with a single layer of the protocol stack. In the case of two of these standards Flexible Advanced Coding and Modulation Scheme for High Rate Telemetry Applications (reference [56]) and CCSDS Space Link Protocols Over ETSI DVB-S2 Standard (reference [57]) this rule has been broken. These standards, which are only suited for high rate telemetry downlinks in near Earth environments, encompass combined modulation, coding, and signaling in a single standard. The DVB-S2 standard also includes its own link layer. Systems that adopt these protocols must understand that they encompass more than a single layer in the following protocol stack building block diagrams.

6.1.2.3 Referenced Cross Support Protocols

Table 6-2 lists the cross support protocols that are referenced in this document and used between an Earth User Node and the ESLT CSSE. Other protocols may be used in addition to these.

CCSDS RECOMMENDED PRACTICE FOR SPACE COMMUNICATIONS CROSS SUPPORT—
 ARCHITECTURE REQUIREMENTS DOCUMENT

Table 6-2: Referenced Cross Support Protocols

Cross Support Link Type	Cross Support Protocol	Reference
Space Link Extension Forward	Space Link Extension—Forward CLTU Service Specification	CCSDS 912.1-B-3 [21]
	Space Link Extension—Enhanced Forward CLTU Service Specification	CCSDS 912.11-O-1 [Opt] [D13]
	Cross Support Transfer Service—Forward Frame	CCSDS White Paper [D14]
Space Link Extension Return	Space Link Extension—Return All Frames Service Specification	CCSDS 911.1-B-3 [22]
	Space Link Extension—Return Channel Frames Service Specification	CCSDS 911.2-B-2 [23]
	SLE Return Operational Control Fields	CCSDS 911.5-B-2 [28]
Application Layer Protocols	Tracking Data Cross Support Transfer Service	CCSDS White Book [D16]
	Cross Support Transfer Service—Transfer File	CCSDS White Paper [D17]
	Cross Support Transfer Service—CFDP File Service	CCSDS White Paper [D15]
	Monitored Data—Cross Support Transfer Services	CCSDS White Book [D18]
	Service Control Cross Support Transfer Service	CCSDS White Book [D19]
	Space Link Extension—Internet Protocol for Transfer Services	CCSDS 913.1-B-1 [52]
	Cross Support Transfer Service—Specification Framework	CCSDS 921.1-R-2 Draft [D6]
	Cross Support Transfer Service—CFDP File Service	CCSDS White Paper [D15]
	Delta-DOR Raw Data Exchange Format	CCSDS 506.1-B-1 [38]
	Delta-Differential One Way Ranging (Delta-DOR) Operations	CCSDS 506.0-M-1 [24]
Service Management	Space Communications Cross Support—Service Management—Service Specification	CCSDS 910.11-B-1 [D9]
	Extensible Space Communication Cross Support Service Management—Concept (ESCCS-SM)	CCSDS 902.0-G [D10]
	Functional Resources for Cross Support Services	CCSDS White Paper [D21]
	XML Specification for Navigation Data Messages	CCSDS 505.0-B-1 [29]
	Orbit Data Messages (ODM)	CCSDS 502.0-B-2 [30]
	Tracking Data Message (TDM)	CCSDS 503.0-B-1 [37]
	Conjunction Data Message (CDM)	CCSDS 508.0-B-1 [40]
	Solar System Internetwork (SSI) Architecture (PAs and coordination function)	CCSDS 730.1-G [D7]

All documents with specific assigned numbers are existing published documents at the time of writing, but several others are currently in development as Red Books (books currently in CCSDS review), White Papers (concept papers), or White Books (early drafts of standards). Check the CCSDS website (<http://public.ccsds.org/default.aspx>) for the current versions of CCSDS documents.

6.1.2.4 Referenced Security Protocols

Table 6-3 lists the security protocols that are referenced in this document and used to support secure space communications and operations. Terrestrial CSSSEs and CSSEs may use other commercial communications protocols that are not listed in this table.

Specific examples of how and where these security protocols and algorithms may be applied are provided in 6.2.2.7 and 6.2.3.7. While these sections provide specific recommendations and diagrams relating to security deployments, the reader should keep in mind that these security protocols and algorithms may equally well be applied, using the methods shown, in any of the other deployments where they are required or appropriate.

Table 6-3: Referenced Security Protocols

Security Standards	Cross Support Protocol	Reference
ABA and SSI		
Space-to-Ground Links	Space Data Link Security Protocol	CCSDS 355.0-R Draft [D22]
Application Layer Protocols	CCSDS Cryptographic Algorithms	CCSDS 352.0-B-1 [7]
	Symmetric Key Management Recommendations	CCSDS White Book [D23]
	CCSDS Guide for Secure System Interconnection	CCSDS 350.4-G-1 [D25]
	Security Architecture for Space Data Systems	CCSDS 351.0-M-1 [6]
SSI Only		
DTN Internetworking Protocols	Bundle Security Protocol Specification	RFC 6257 [15]
	Streamlined Bundle Security Protocol for CCSDS	CCSDS White Book [D26]
IP Internetworking Protocols	Security Architecture for the Internet Protocol	RFC 4301 [53]
	IP Encapsulating Security Payload (ESP)	RFC 4303 [54]
	HTTP Over TLS	RFC 2818 [55]
	FTP Security Extensions	RFC 2228 [26]

All documents with specific assigned numbers are existing published documents or drafts (Red Books) released for international review as of the time of writing; other documents are White Papers (concept papers) or White Books (proposed standards). The CCSDS Web site (<http://public.ccsds.org/default.aspx>) contains the current versions of CCSDS documents.

CCSDS RECOMMENDED PRACTICE FOR SPACE COMMUNICATIONS CROSS SUPPORT—
 ARCHITECTURE REQUIREMENTS DOCUMENT

6.2 PROTOCOL BUILDING BLOCKS

6.2.1 OVERVIEW

6.2.1.1 ABA Configuration Protocol Building Blocks

This subsection introduces ABA protocol building blocks, and each of the following diagrams presents one or more ABA protocol building blocks. Each diagram describes the recommended stack of protocols for use in specific link layer configurations. Most of these are suitable only for ABA configurations, but some are suitable for both SSI and ABA configurations and provide a forward growth path. Extensive descriptive material on these ABA protocol building blocks may be found in subsection 6.5.1 of the SCCS-ADD (reference [D5]). Section 7 shows how to configure these protocol building blocks to meet the needs of specific end-to-end configurations.

Throughout this section, table columns labeled SM represent the service management protocol (service management is spelled out elsewhere throughout the document).

6.2.1.2 ABA ESLT Service-Provider Protocol Recommendations

Table 6-4 lists the terrestrial side standard suite of protocols for ABA ESLT. These are referenced by the requirements in this section.

Table 6-4: Required and Optional ABA ESLT Terrestrial Side Protocols

Functions (Protocols)	RAF	RCF	F-CLTU	EF-CLTU	SM
SLE RAF	X				
SLE RCF		X			
SLE FCLTU			X		
SLE EF-CLTU				opt	
Service Planning and Scheduling					X
Service Request and Trajectory Files					X
Service Accountability					X
Secure Hypertext Transfer Protocol (SHTTP)					X
TCP	X	X	X	X	X
IP	X	X	X	X	X
Ground Data Link and Physical	X	X	X	X	X

NOTES

- 1 All of the SLE (and CSTS) specifications depend upon a common underlying transport protocol for interoperability (reference [52]).

- 2 EF-CLTU (reference [D9]) is available now and may be optionally deployed for users needing forward AOS. F-Frame (reference [D14]) is the future spec that is preferentially to be deployed when it is available.

Table 6-5 lists the space-side standard suite of protocols for ABA ESLT. These are referenced by the requirements in this section. The column labeled SM represents the service management protocol (SM is spelled out elsewhere within the document).

Table 6-5: Required and Optional ABA ESLT Space Side Protocols

Functions (Protocols)	RAF	RCF	F-CLTU	EF-CLTU	SM
TM Space Data Link Protocol		X			
AOS Space Data Link Protocol		X		opt	
TM Sync and Channel Coding	X	X		opt	
TC Space Data Link Protocol					
TC Sync and Channel Coding					
RF and Modulation	X	X	X	X	

Figure 6-1 shows the recommended protocol stack for ABA ESLT installations. The terrestrial link interface uses SLE and CSTS protocols over TCP/IP for data transport and the service management and associated protocols over HTTPS and TCP/IP for planning and scheduling. The space link interface uses the CCSDS space link, coding, modulation, and RF protocols.

CCSDS RECOMMENDED PRACTICE FOR SPACE COMMUNICATIONS CROSS SUPPORT—
 ARCHITECTURE REQUIREMENTS DOCUMENT

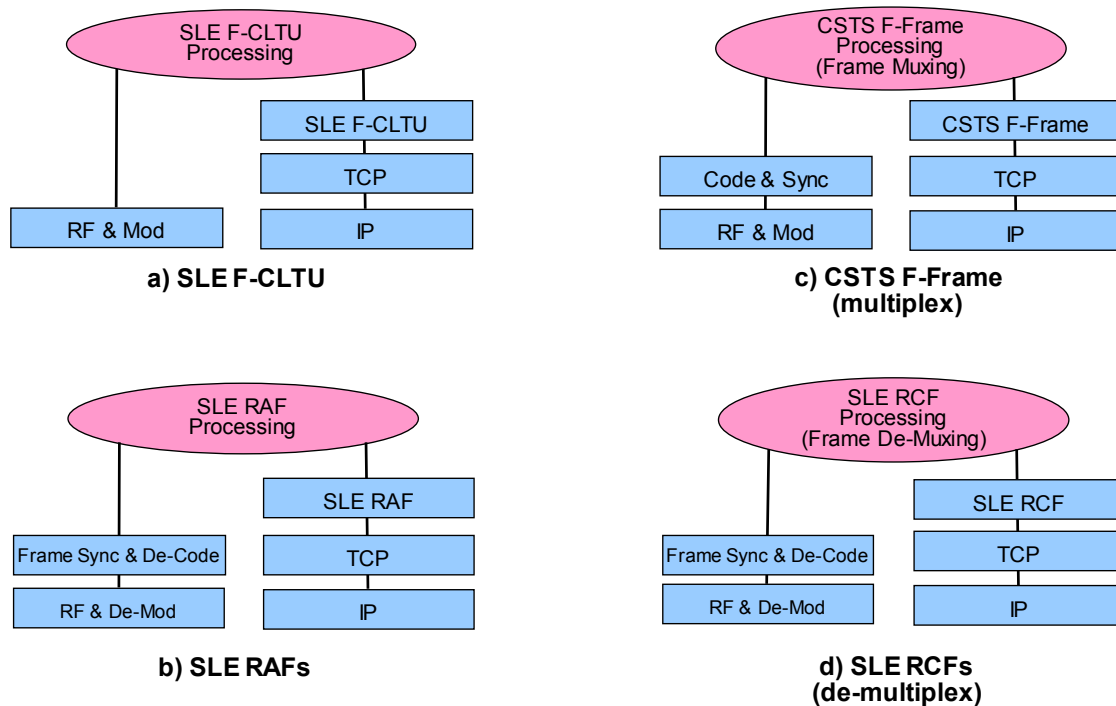

Figure 6-1: ABA ESLT Protocol Building Blocks

6.2.2 ABA PROTOCOL STACK REQUIREMENTS

6.2.2.1 ABA ESLT Service-Provider Building Blocks

6.2.2.1.1 All ABA ESLTs implementing SLE communication protocol stacks shall comply with Space Link Extension—Internet Protocol for Transfer Services (reference [52]) (figure 6-1a, b, and d).

6.2.2.1.2 ABA ESLTs transporting F-CLTU (encoded TC frames, see reference [31]) data shall implement a terrestrial communication protocol stack including SLE F-CLTU service-provider agent (reference [21]), CLTU processing (reference [8]), and a space communication protocol stack with RF and modulation (reference [34]) (figure 6-1a).

6.2.2.1.3 ABA ESLTs transporting return AOS (reference [9]) or TM (reference [10]) frame data shall implement a space communication protocol stack including RF and modulation (reference [34]), TM synchronization and de-coding (reference [32]), and a terrestrial SLE RAF service-provider agent (reference [22]) (figure 6-1b).

6.2.2.1.4 ABA ESLTs transporting return AOS or TM frame data shall implement a space communication protocol stack including compliant TM synchronization and de-coding (reference [32]), VC de-multiplexing, and a terrestrial SLE RCF service-provider agent to deliver data to multiple users (reference [23]) (figure 6-1d).

6.2.2.1.5 ABA ESLTs transporting near Earth high data rate return data may implement a space communication protocol stack including RF, high rate modulation and coding (reference [56] or [57]), TM synchronization and de-coding (reference [32]), and a terrestrial SLE RAF service-provider agent (reference [22]) (reference figure 6-1b).

6.2.2.2 Future ABA Service-Provider Requirements

6.2.2.2.1 [Future] All ABA ESLTs implementing CSTS communication protocol stacks shall comply with Space Link Extension—Internet Protocol for Transfer Services (reference [52]) (figures 6-1c, 6-2, 6-5, 6-6, 6-8).

6.2.2.2.2 [Future] All ABA ESLTs implementing CSTS communication protocol stacks shall comply with the Cross Support Transfer Service—Specification Framework (reference [D6]) (figures 6-1c, 6-2, 6-5, 6-6, 6-7).

6.2.2.2.3 [Future] ABA ESLTs transporting forward AOS and TC frame data should implement a terrestrial communication protocol stack including a CSTS F-Frame provider agent (reference [D14]) to accept data from multiple users, and a forward space communication protocol stack including AOS or TC frame processing and multiplexing, coding and synchronization (references [8], [9], [31], [32]), and RF and modulation (reference [34]) (figure 6-1c).

NOTE – EF-CLTU (reference [D9]) is available now and may be optionally deployed for users needing forward AOS. F-Frame (reference [D14]) is the future spec that is preferentially to be deployed when it is available.

6.2.2.2.4 [Future] ABA ESLTs implementing the CSTS F-Frame service and compliant coding and synchronization must implement the COP (reference [33]) and Physical Link Operations Procedure (PLOP) (reference [8]) protocols (figure 6-1c) for use when requested.

6.2.2.2.5 [Future] ABA ESLTs supporting real-time radiometric, Doppler, and tracking data services should implement ranging sequence generation (references [34], [36]) (figure 6-2).

6.2.2.2.6 [Future] ABA ESLTs supporting real-time radiometric, Doppler, and tracking data services should implement radiometric data processing (references [34], [36]) and the terrestrial CCSDS CSTS tracking data service-provider agent to deliver data (reference [D16]) (figure 6-2).

6.2.2.2.7 [Future] ABA ESLTs supporting ranging and radiometric data should implement the service control provider agent (reference [D19]) as the means to control ranging sequence generation (references [34] or [36]) (uses figure 6-6).

CCSDS RECOMMENDED PRACTICE FOR SPACE COMMUNICATIONS CROSS SUPPORT—
 ARCHITECTURE REQUIREMENTS DOCUMENT

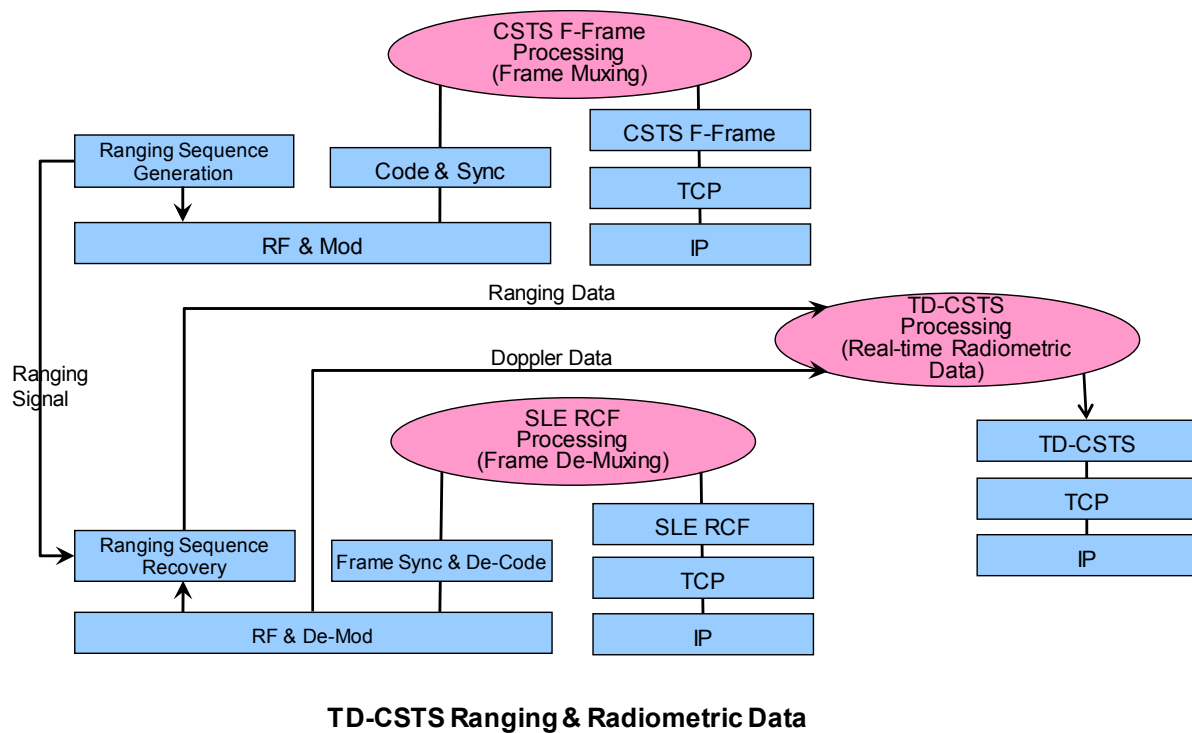

Figure 6-2: ABA ESLT Radiometric Processing Protocol Building Blocks

6.2.2.2.8 [Future] ABA ESLTs supporting off-line radiometric, Doppler, and tracking data services should implement the terrestrial CCSDS transfer file service-provider agent to deliver data (reference [D17]) (figure 6-9).

6.2.2.2.9 [Future] ABA ESLTs supporting radiometric, Doppler, and tracking data services should implement the NDM eXtensible Markup Language (XML) data format (reference [29]) for returned data (figure 6-2).

6.2.2.2.10 [Future] ABA ESLTs supporting radiometric, Doppler, and tracking data services may implement the TDM data format (reference [37]) for returned data (figure 6-2).

NOTES

- 1 Figure 6-3a shows the recommended service management protocol stack for an ABA ESLT installation. Figure 6-3b shows the corresponding Earth user stack. All service planning, scheduling, configuration, and reporting use this interface.
- 2 At the time of writing the service management protocol (reference [D9]) only supports configuration and request of telemetry and command services. In-development extensions to this existing specification (reference [D10]) will support request of radiometric tracking, Delta-DOR, as well as planning requests, schedules, and accountability reports.

6.2.2.2.11 [Future] All ABA ESLTs providing CCSDS-compliant cross support services shall implement the service management protocols over HTTPS (references [50], [55]) and TCP/IP (references [47], [48]) to provide users with the means to securely schedule and configure space communications services (figure 6-3).

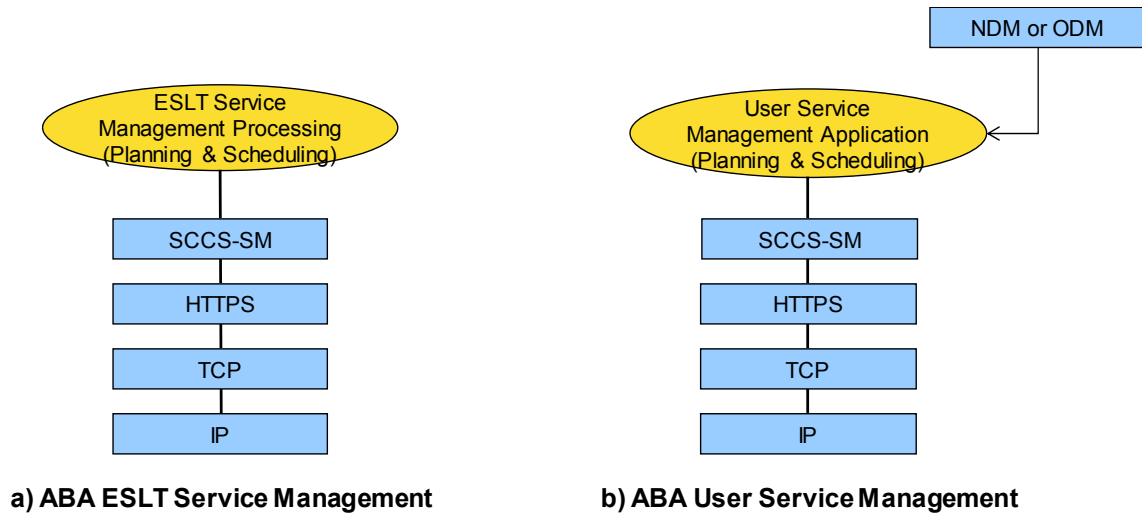

Figure 6-3: ABA ESLT Service Management Protocol Building Blocks

6.2.2.2.12 ABA ESLTs providing cross support services shall implement the bilateral service management agreements to provide users with the means to schedule and configure space communications services (figure 6-3a).

6.2.2.2.13 ABA ESLTs providing cross support services shall accept NDM (reference [29]) or ODM (reference [30]) files transferred within the CCSDS service management protocol (reference [D9]) to provide spacecraft trajectory or orbit data (figure 6-3b).

6.2.2.2.14 [Future] ABA ESLTs providing cross support services should implement CCSDS network schedule interface (reference [D10]) to identify the expected times for scheduled space communications services (figure 6-3a with extended service management).

6.2.2.2.15 [Future] ABA ESLTs providing cross support services should implement CCSDS service-agreement interface (reference [D10]) to define and arrange for delivery of space communications services (figure 6-3a with extended service management).

6.2.2.2.16 [Future] ABA ESLTs providing cross support services should implement a CCSDS Service Catalog interface (reference [D10]) to specify and characterize available space communications services (figure 6-3a with extended service management).

6.2.2.2.17 [Future] ABA ESLTs providing cross support services should implement a CCSDS service-accountability interface to accept requests and deliver service accountability reports (reference [D10]).

CCSDS RECOMMENDED PRACTICE FOR SPACE COMMUNICATIONS CROSS SUPPORT—
 ARCHITECTURE REQUIREMENTS DOCUMENT

NOTE – Internal to the systems that implement CCSDS service management the scheduled service, trajectory, and configuration, information is passed into the PM elements that do service configuration, execution, and control. These are shown in figure 6-4 as ‘ESLT Service Management Processing (Configuration and Execution)’. These do not interact directly with the users, and they may not directly utilize the SCCS-SM protocols, but they are the sinks for the information conveyed by those protocols.

6.2.2.2.18 ABA ESLTs providing cross support services shall implement ESLT service management processing that translates SCCS-SM schedules, configurations, and sequences (reference [D10]) into internal forms used to manage the systems that execute user services (figure 6-4).

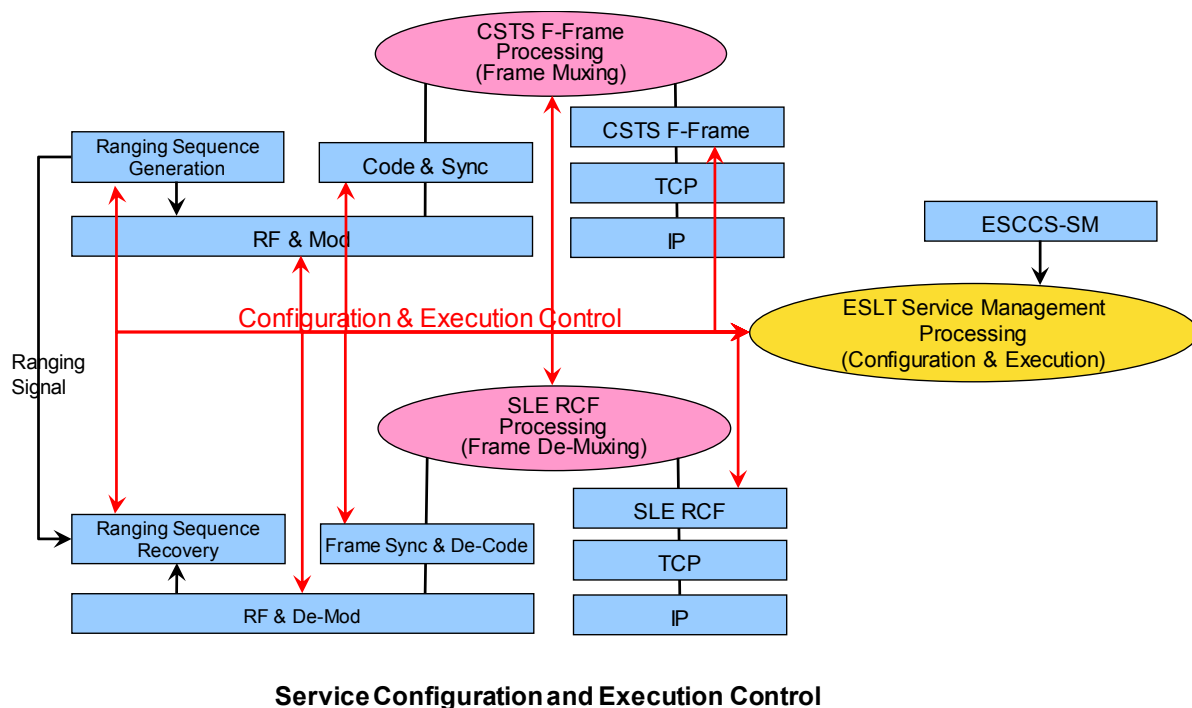

Figure 6-4: ABA ESLT Service Management Configuration and Execution Building Blocks

NOTES

- 1 As the service execution subsystems are executing, they provide monitor data to the internal control elements of the system. Subsets of these monitor data are also provided to the users via the monitor data interface. Figure 6-5 shows this protocol stack configuration and a subset of the monitor data that may be provided. Most functional resources produce one or more data items that may be made accessible.
- 2 The service control interface provides users with the means to control a subset of the functions in the system. Figure 6-6 shows this protocol stack configuration and a

subset of the service control parameters that may be offered. Many functional resources have one or more service control parameters that may be made accessible.

6.2.2.2.19 [Future] ABA ESLTs providing cross support services should implement access to service monitor data and the terrestrial CSTS monitor data service-provider agent (reference [D18]) (figure 6-5).

6.2.2.2.20 [Future] ABA ESLTs providing a monitor data cross support service shall implement the monitor data-CSTS protocol (reference [D18]) over TCP/IP (reference [47], [48]) to provide users with the means to securely monitor space communications services (figure 6-5).

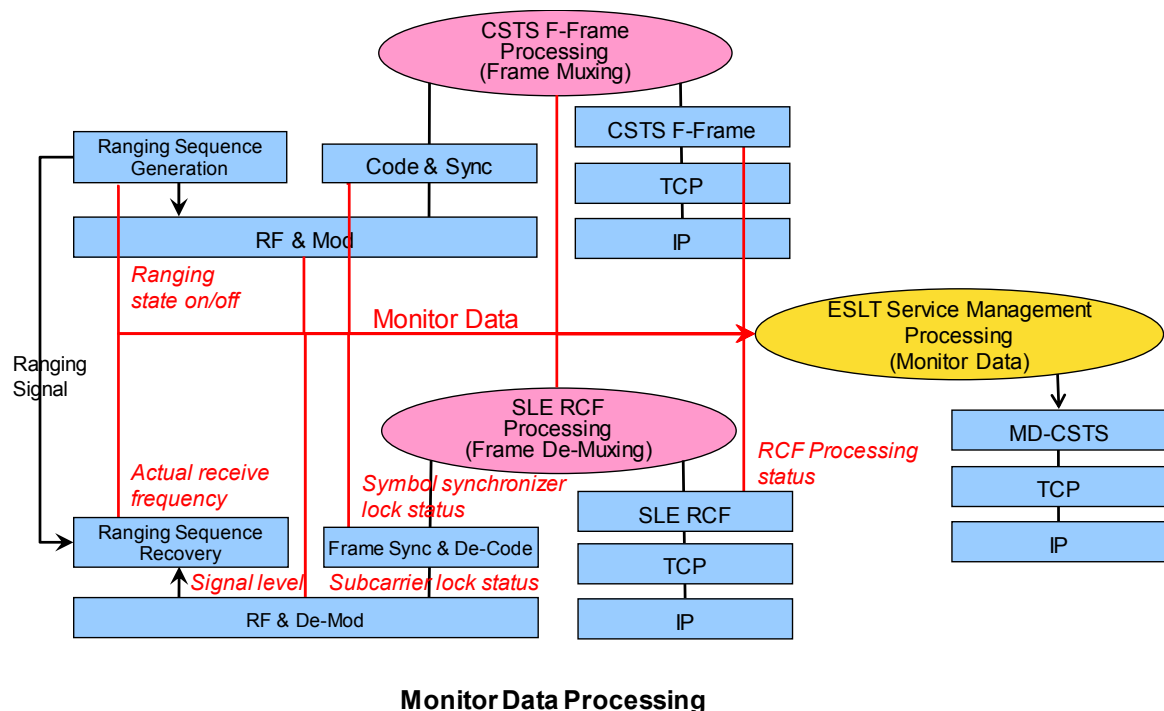

Figure 6-5: ABA ESLT Monitor Data Protocol Building Blocks

6.2.2.2.21 [Future] ABA ESLTs implementing the terrestrial CSTS monitor data service-provider agent shall deliver monitor data to more than one simultaneous user (reference [D18]) (figure 6-5).

6.2.2.2.22 [Future] ABA ESLTs providing cross support services should implement a core set of service control functions and the terrestrial CSTS service control service-provider agent (reference [D19]) (figure 6-6).

6.2.2.2.23 [Future] ABA ESLTs providing a service control cross support service shall implement the service control-CSTS protocols (reference [D19]) over TCP/IP (references [47], [48]) to provide users with the means to securely control space communications services (figure 6-6).

CCSDS RECOMMENDED PRACTICE FOR SPACE COMMUNICATIONS CROSS SUPPORT—
 ARCHITECTURE REQUIREMENTS DOCUMENT

6.2.2.2.24 [Future] ABA ESLTs implementing the CSTS service control service-provider agent shall provide a service control interface to only one user at a time (reference [D19]) (figure 6-6).

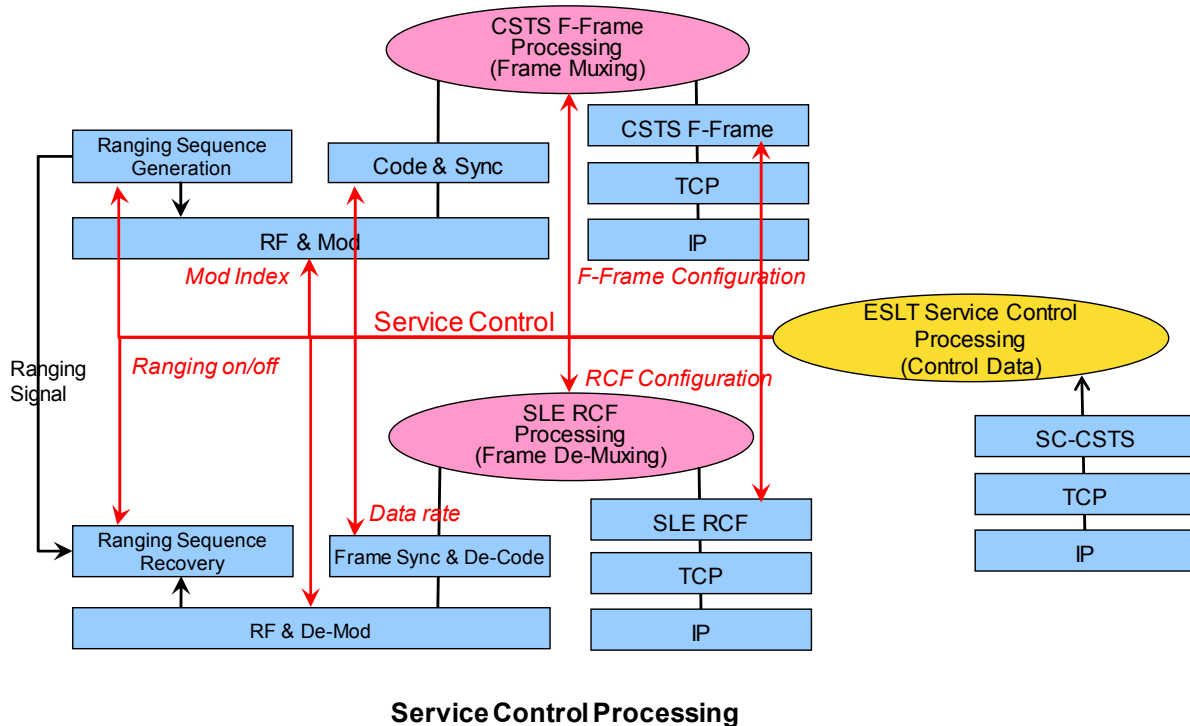

Figure 6-6: ESLT Service Control Service-Provider Protocol Stack Building Blocks

NOTE – Some ESLTs, particularly those serving deep space missions, will implement a CCSDS-compliant Delta-DOR service to provide precise plane-of-sky positions. Figure 6-7 shows ESLT Delta-DOR processing, described in reference [24]. Delta-DOR observations require two or more ESLTs that are on wide north-south and east-west baselines. Delta-DOR produces large volumes of data that are later post-processed to provide accurate tracking information.

6.2.2.2.25 [Opt] ABA ESLTs providing high-precision plane-of-sky position information should implement the Delta-DOR service (references [24], [34]) (figure 6-7).

6.2.2.2.26 [Opt] ABA ESLTs supporting high-precision plane-of-sky Delta-DOR service should implement the Delta-DOR open loop signal reception functions (reference [34], [24]) to receive DOR tones (reference [34]) (figure 6-7).

6.2.2.2.27 [Opt] ABA ESLTs supporting high-precision plane-of-sky Delta-DOR service should implement the Delta-DOR RDEF (reference [38]) to transfer raw Delta-DOR data to another ESLT, or Earth User Node, for processing (figure 6-7).

6.2.2.2.28 [Opt] ABA ESLTs supporting high-precision plane-of-sky Delta-DOR service should implement the Delta-DOR correlation-processing function as the means to create processed tracking data (reference [24]) (figure 6-7).

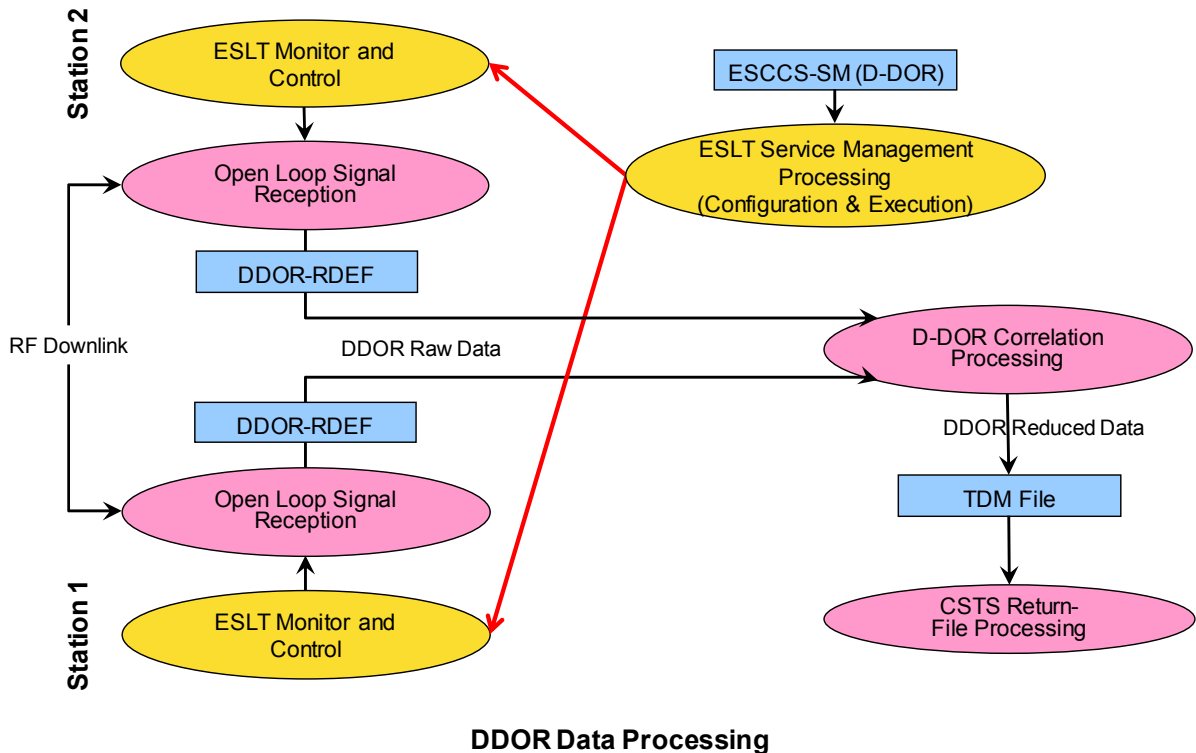

Figure 6-7: ESLT Delta-DOR Service-Provider Protocol Stack Building Blocks

6.2.2.2.29 [Opt][Future] ABA ESLTs supporting high-precision plane-of-sky Delta-DOR correlation processing should implement the service control service-provider agent (reference [D19]) as the means to control Delta-DOR tracking (reference [24]) (uses figure 6-6).

6.2.2.2.30 [Opt][Future] ABA ESLTs supporting high-precision plane-of-sky Delta-DOR correlation processing should implement the TDM (reference [37]) or NDM (reference [29]) file data format for returned data (figure 6-7).

NOTES

- 1 Figure 6-8a shows the recommended protocol stack for an ABA ESLT installation that supports the CSTS forward-file service. The CSTS F-Frame service, with frame merging, is required to support this. Figure 6-8b is the CSTS Earth User Node configuration for this service.

CCSDS RECOMMENDED PRACTICE FOR SPACE COMMUNICATIONS CROSS SUPPORT—
ARCHITECTURE REQUIREMENTS DOCUMENT

- 2 The forward-file service uses the CSTS transfer file protocol to deliver the file to the ESLT, and the ESLT implements the transfer of that file using CFDP internal to the ESLT.

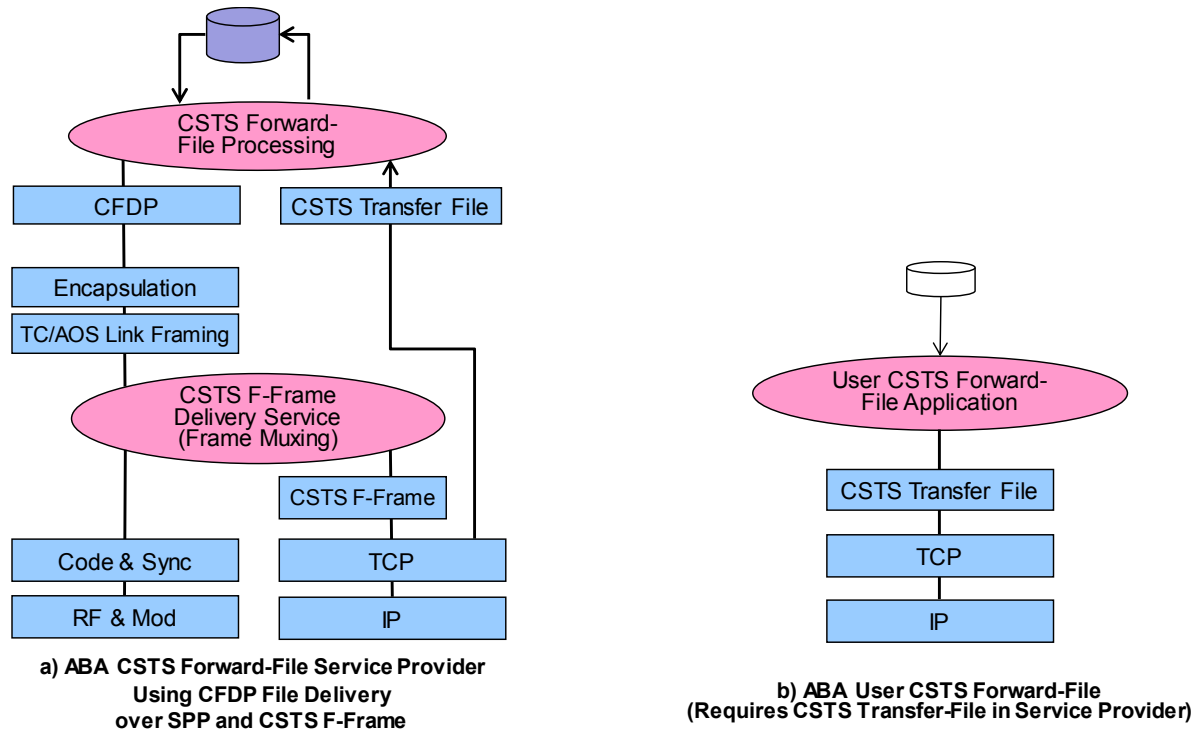

Figure 6-8: ABA ESLT Forward-File Protocol Building Blocks

6.2.2.2.31 [Future] ABA ESLTs offering the forward CFDP file service should implement a forward terrestrial communication protocol stack including the CSTS transfer file protocol, a terrestrial forward CSTS transfer file service-provider agent (reference [D17]) and CSTS forward CFDP file processing (reference [D15]) (figure 6-8a).

6.2.2.2.32 [Future] ABA ESLTs implementing forward CFDP file processing should implement a forward space communication protocol stack including CFDP processing and encapsulation, AOS or TC frame protocols, F-Frame service merging, coding and synchronization, and RF and modulation protocols (references [14], [D14], [39], [42], and others]) (figure 6-8a).

NOTE – Figure 6-9 shows the return CFDP file service (reference [D15]) using the CSTS transfer file protocol (reference [D17]) to deliver the file from the ESLT to the user, and the ESLT implements the processing of that file using CFDP internal to the ESLT. Figure 6-9 also shows CSTS return file processing providing the means to transfer radiometric data (reference [37]) or Delta-DOR processed data (reference [24]). The same CSTS transfer file delivery agent and protocol provides the protocol stack and interface for all three data types.

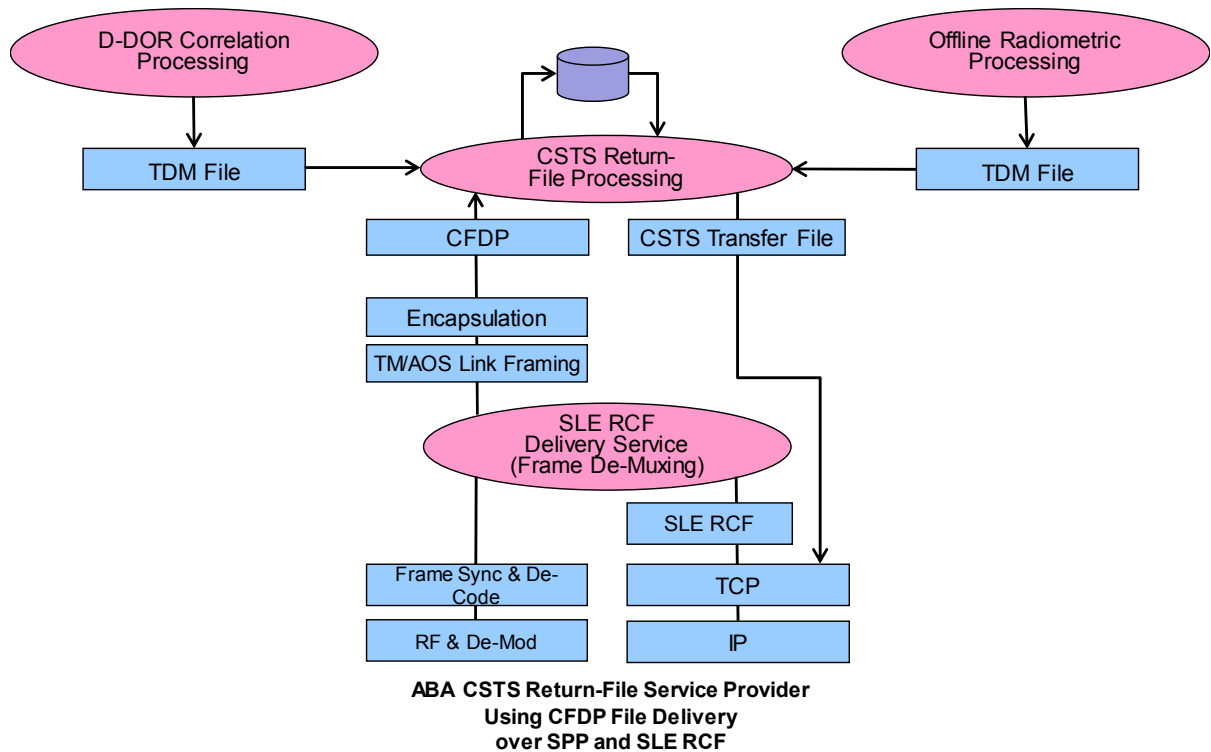

Figure 6-9: ABA ESLT Return File Protocol Building Blocks

6.2.2.2.33 [Future] ABA ESLTs offering the return CFDP file service should implement a return space communication protocol stack including RF, demodulation, AOS or TM frame synchronization and decoding, the RCF service, frame and packet processing, and CFDP processing (references [23], [39]) (figure 6-9).

NOTE – ABA ESLTs implementing CFDP Class 2 must provide a feedback path for retransmission requests between the forward and return CFDP agents (not shown).

6.2.2.2.34 [Future] ABA ESLTs offering the return CFDP file service should implement a return terrestrial communication protocol stack using the CSTS return file processing and a return CSTS transfer file service-provider agent (references [D15], [D17]) (figure 6-9).

6.2.2.2.35 [Future] ABA ESLTs offering off-line radiometric delivery service should implement a return communication protocol stack using the TDM (reference [37]) or NDM (reference [29]) data format and the CSTS transfer file service-provider agent (reference [D17]) (figure 6-9).

6.2.2.2.36 [Future] ABA ESLTs offering Delta-DOR correlation data-processing service should implement a return communication protocol stack using the TDM (reference [37]) or NDM (reference [29]) data format and the CSTS transfer file service-provider agent (reference [D17]) (figure 6-9).

CCSDS RECOMMENDED PRACTICE FOR SPACE COMMUNICATIONS CROSS SUPPORT—
 ARCHITECTURE REQUIREMENTS DOCUMENT

6.2.2.3 Discussion—ABA Earth User Node Protocol Recommendations

Table 6-6 lists the required and optional ABA Earth User Node standard suite of protocols that are referenced by the requirements in this section.

Table 6-6: Required and Optional ABA Earth User Node Protocols

Functions (Protocols)	RAF	RCF	F-CLTU	EF-CLTU	SM
CFDP or AMS	opt	opt	opt	opt	
SPP or EP	opt	opt	opt	opt	
TM Space Data Link Protocol	X	X			
AOS Space Data Link Protocol	X	X		X	
TC Space Data Link Protocol			X	X	
TC Sync and Channel Coding			X		
SLE RAF	X				
SLE RCF		X			
SLE F-CLTU			X		
SLE EF-CLTU				X	
Service Planning and Scheduling					X
Service Request and Trajectory Files					X
Service Accountability					X
SHTTP					X
TCP	X	X	X	X	X
IP	X	X	X	X	X
Ground Data Link and Physical	X	X	X	X	X

Figure 6-10 shows the recommended protocol stack for ABA Earth User installations. The terrestrial link interface uses SLE or CSTS protocols over TCP/IP for forward data transport to the ESLT.

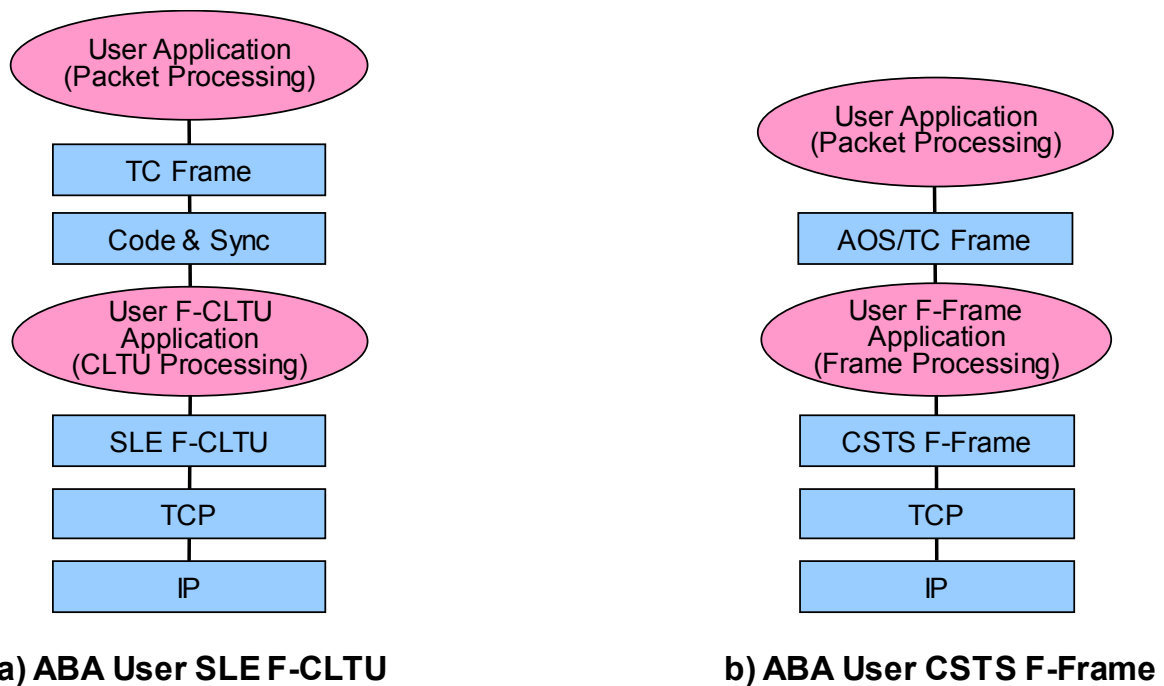

Figure 6-10: ABA Earth User Forward Protocol Building Blocks

6.2.2.4 ABA Protocol Stack Requirements for ABA Earth User Building Blocks

6.2.2.4.1 All ABA Earth User Nodes implementing SLE communication protocol stacks shall comply with Space Link Extension—Internet Protocol for Transfer Services (reference [52]) (figures 6-10a, 6-11a, b, c).

6.2.2.4.2 [Future] All ABA Earth User Nodes implementing CSTS communication protocol stacks shall comply with Space Link Extension—Internet Protocol for Transfer Services (reference [52]) (figures 6-10b and 6-12a, b, c).

6.2.2.4.3 [Future] ABA Earth User Nodes implementing CSTS communication protocol stacks shall comply with the Cross Support Transfer Service—Specification Framework (reference [D6]) (figures 6-1c; 6-10b; 6-12a, b, c).

6.2.2.4.4 ABA Earth User Nodes transporting CLTU shall implement a forward communication protocol stack using TC frames (reference [31]), TC-compliant coding and synchronization (reference [8]), and an SLE F-CLTU user client (reference [21]) (figure 6-10a).

6.2.2.4.5 ABA Earth User Nodes implementing the SLE F-CLTU user client and requiring reliable frame-level data delivery for RTLT less than one (1) second should implement the COP FOP (reference [33]) protocol (inside TC frame processing, figure 6-10a) using CLCWs from the return link.

CCSDS RECOMMENDED PRACTICE FOR SPACE COMMUNICATIONS CROSS SUPPORT—
ARCHITECTURE REQUIREMENTS DOCUMENT

6.2.2.4.6 [Future] ABA Earth User Nodes transporting framed data should implement a forward communication protocol stack using AOS or TC frames and a CSTS F-Frame user client (reference [D14]) (figure 6-10b).

NOTES

- 1 For F-Frame service, the COP, where required, is implemented in the ESLT.
- 2 Figure 6-11 shows two Earth User Node return stacks, one that uses either RAF or RCF user clients, and the other that shows the deployment of a CFDP return-file application within the Earth user.

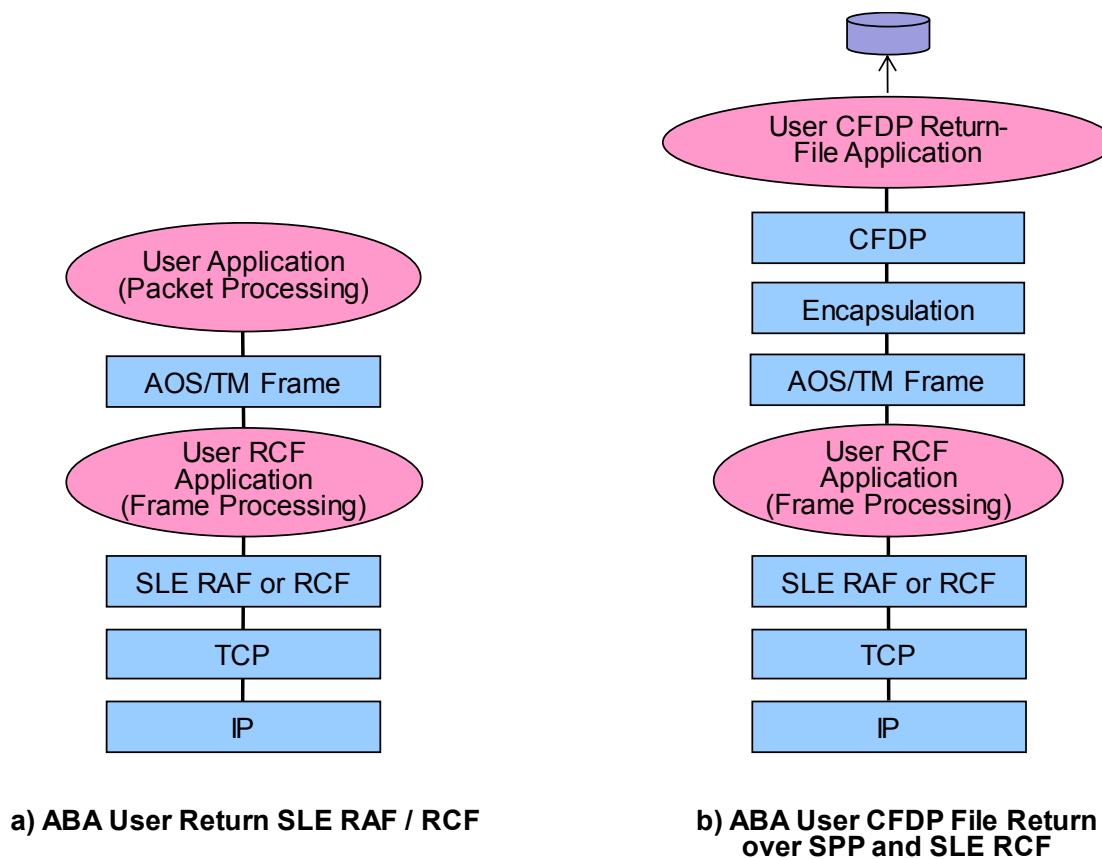

Figure 6-11: ABA Earth User Node Return Protocol Building Blocks

6.2.2.4.7 ABA Earth User Nodes receiving framed data shall implement a return communication protocol stack using TM (reference [10]) or AOS (reference [9]) frames and an SLE RAF or RCF user client (reference [22] or [23]) (figure 6-11a).

6.2.2.4.8 ABA Earth User Nodes requiring reliable frame-level data delivery and with RTLT less than a few seconds should extract the CLCW sent by the COP (reference [33]) (inside TM frame processing, figure 6-11a) and signal the FOP of the need for frame retransmission.

NOTE – The effective limit for use of the COP is how many frames are in transit. The COP deals with round trip light time and limits the report to 128 frames. The limitation is $128 > \text{RTL T} \times \text{data rate} / \text{frame size}$. In practical terms, above a few seconds missions tend to adopt pre-empting re-command transmission approaches.

6.2.2.4.9 ABA Earth User Nodes transporting return file data using CFDP (reference [39]) should implement a return communication protocol stack using CFDP, either SPP or EP encapsulation, and either the RAF or RCF user client (references [42], [14], [22], [23]) (figure 6-11b).

6.2.2.4.10 ABA Earth User Nodes transporting forward-file data using CFDP (reference [39]) should implement a forward communication protocol stack using CFDP, either SPP or EP encapsulation, and the F-CLTU interface (references [42], [14], [21]) (symmetric with figure 6-11b).

6.2.2.4.11 ABA Earth User Nodes may send other application data forms by implementing a forward and return communication protocol stack with application protocols such as AMS (reference [41]), CFDP (reference [39]), or other, and either SPP or EP encapsulation, over the space link (similar to figure 6-11b).

6.2.2.4.12 [Future] ABA Earth User Nodes transporting file data may implement a forward communication protocol stack using the forward CSTS transfer file user client (reference [D17]) and the forward CFDP File Service (reference [D15]) in the ESLT (figure 6-8b).

6.2.2.4.13 [Future] ABA Earth User Nodes transporting file data may implement a return communication protocol stack using the return CSTS transfer file user client (reference [D17]) and the return CFDP file service (reference [D15]) in the ESLT (symmetric to figure 6-8b).

NOTE – ABA Earth User Nodes may require access to real-time radiometric data, monitor data, or to service-control interfaces. Figure 6-12 shows the user side of these interfaces.

6.2.2.4.14 [Future] ABA Earth User Nodes requiring real-time monitor data should implement a CSTS monitor data user client protocol stack (reference [D18]) to monitor service provider and link status (figure 6-12b).

6.2.2.4.15 [Future] ABA Earth User Nodes requiring the ability to change service-provider parameters in real time should implement a CSTS service control user client protocol stack (reference [D19]) to request these changes (figure 6-12c).

CCSDS RECOMMENDED PRACTICE FOR SPACE COMMUNICATIONS CROSS SUPPORT—
ARCHITECTURE REQUIREMENTS DOCUMENT

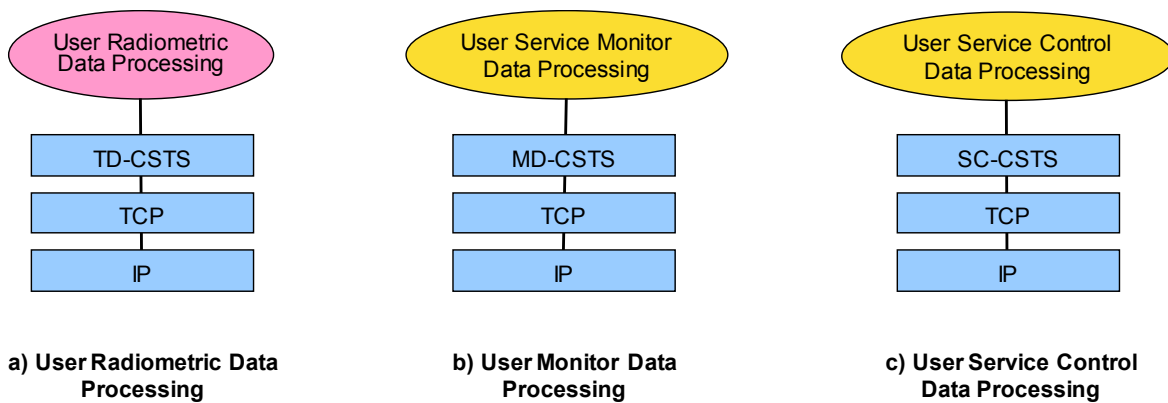

Figure 6-12: ABA Earth User Radiometric, Monitor and Control Protocol Building Blocks

6.2.2.4.16 [Future] ABA Earth User Nodes requiring real-time radiometric data should implement a CSTS tracking data user client protocol stack (reference [D16]) to receive these data (figure 6-12a).

6.2.2.4.17 [Future] ABA Earth User Nodes requiring ranging and radiometric data should implement the service control user client (reference [D19]) as the means to control ranging sequence generation (reference [34] or [36]) (uses figure 6-12c).

6.2.2.4.18 [Future] ABA Earth User Nodes requiring off-line delivery of tracking data should implement a return communication protocol stack using the TDM (reference [37]) or NDM (reference [29]) data format and the CSTS transfer file service user client (reference [D17]) (symmetric with figure 6-8a).

6.2.2.4.19 ABA Earth User Nodes requiring radiometric and tracking data should implement functions that process the TDM data format (reference [37]) (related to figure 6-12a).

6.2.2.4.20 [Future] ABA Earth User Nodes requiring radiometric and tracking data should implement functions that process the NDM XML data format (reference [29]) (related to figure 6-12a).

6.2.2.4.21 [Opt] ABA Earth User Nodes requiring high-precision plane-of-sky position information should implement the Delta-DOR protocols (reference, [24], [34]) (figure 6-7).

6.2.2.4.22 [Opt] ABA Earth User Nodes requiring Delta-DOR tracking (reference [24]) may use the Quasar Catalog stored in the SANA radio sources registry (reference [19]) for observation planning (figure 6-16b).

NOTE – Delta-DOR operations also require recording of RF emissions from extra-galactic radio sources, i.e. Quasars (figure 6-16b). These sources are managed in a Quasar catalog described in (reference [24]) and stored in the SANA radio source registry (reference [19]).

6.2.2.4.23 [Opt][Future] ABA Earth User Nodes requiring high-precision plane-of-sky tracking data should implement the service control user client (reference [D19]) as the means to control Delta-DOR tracking (reference [24]) (uses figure 6-12c).

6.2.2.4.24 [Opt] Earth User Nodes requiring high-precision plane-of-sky Delta-DOR service may implement the Delta-DOR RDEF (reference [38]) to transfer raw Delta-DOR data from an ESLT or another source for processing (figure 6-7).

6.2.2.4.25 [Opt] Earth User Nodes requiring high-precision plane-of-sky Delta-DOR service should implement the Delta-DOR correlation processing function as the means to create processed tracking data (reference [24]) (figure 6-7).

6.2.2.4.26 [Future] ABA Earth User Nodes requiring high-precision plane-of-sky tracking data should implement a return communication protocol stack using the TDM (reference [37]) data format and the CSTS transfer file service user client (reference [D17]) (symmetric with figure 6-8a).

NOTE – ABA Earth User Nodes must implement the necessary service management protocols for planning, scheduling, and configuring space link communications services to access ESLT planning and scheduling interfaces (figure 6-3b). ABA Earth User Nodes may implement these protocols themselves, but it is anticipated that many ESLT service providers will offer Web-site interfaces that mask these details from the users.

6.2.2.4.27 All ABA Earth User Nodes requiring cross support services shall implement the service management protocols over HTTPS (references [55], [50]) and TCP/IP (reference [47], [48]) to provide users with the means to securely schedule and configure space communications services (figure 6-6a,b).

6.2.2.4.28 ABA Earth User Nodes doing planning and scheduling for cross support services shall implement bilateral service management agreements to schedule and configure space communications services (figure 6-3b).

6.2.2.4.29 ABA Earth User Nodes doing planning and scheduling for cross support services should implement the NDM XML data format (reference [29]) to transmit spacecraft orbit or ephemeris data as part of a service request (figure 6-3b).

6.2.2.4.30 ABA Earth User Nodes doing planning and scheduling for cross support services may implement the ODM data format (reference [30]) to transmit spacecraft orbit or ephemeris data as part of a service request (figure 6-3b).

6.2.2.4.31 [Future] ABA Earth User Nodes requiring cross support should implement a CCSDS network schedule protocol stack (reference [D10]) to determine expected times for scheduled space communications services (figure 6-3b with extended SM).

CCSDS RECOMMENDED PRACTICE FOR SPACE COMMUNICATIONS CROSS SUPPORT—
 ARCHITECTURE REQUIREMENTS DOCUMENT

6.2.2.4.32 [Future] ABA Earth User Nodes requiring cross support should implement a CCSDS service-agreement protocol stack (reference [D10]) to define and arrange for delivery of space communications services (figure 6-3b with extended SM).

6.2.2.4.33 [Future] ABA Earth User Nodes requiring cross support should implement a CCSDS Service Catalog protocol stack (reference [D10]) to identify and characterize available space communications services (figure 6-3b with extended SM).

6.2.2.4.34 [Future] ABA Earth User Nodes requiring cross support services should implement a CCSDS service accountability interface (reference [D10]) to request and accept delivery of service accountability reports (reference [D10]).

6.2.2.5 Discussion—ABA Space User Node Protocol Recommendations

Table 6-7 lists the required and optional ABA Space User Node standard suite of protocols. These are referenced by the requirements in this section.

Table 6-7: Required and Optional ABA Space User Node Protocols

Functions (Protocols)	RAF	RCF	F-CLTU	EF-CLTU	SM
CFDP or AMS	opt	opt	opt	opt	
SPP or EP	opt	opt	opt	opt	
TM Space Data Link Protocol	X	X			
AOS Space Data Link Protocol	X	X		X	
TM Sync and Channel Coding	X	X		X	
TC Space Data Link Protocol			X		
TC Sync and Channel Coding			X		
RF and Modulation	X	X	X	X	

Figures 6-13 and 6-14 show the recommended protocol stacks for ABA Space User Nodes. The space link interface uses CCSDS link layer protocols and may use optional upper layer protocols like CFDP.

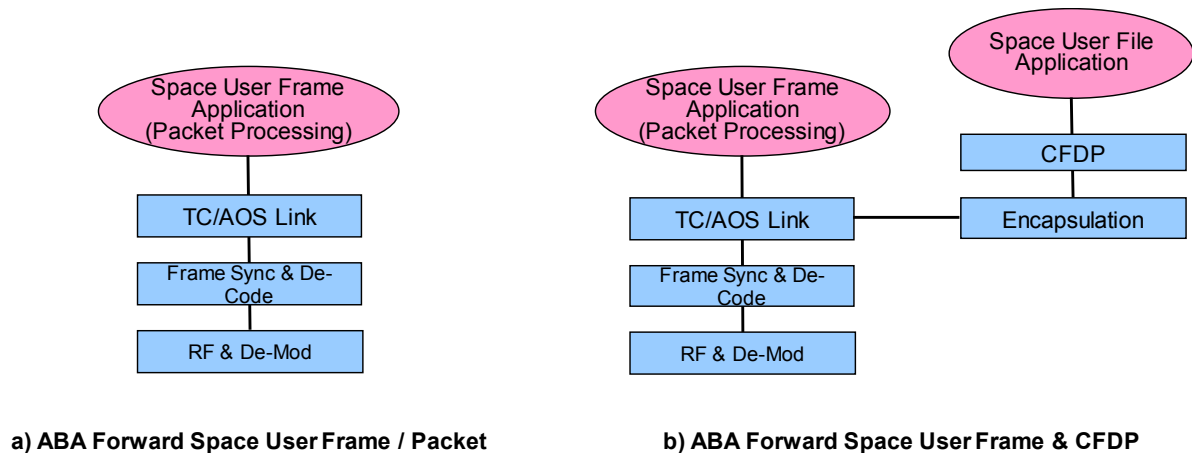

Figure 6-13: ABA Space User Forward Protocol Building Blocks

6.2.2.6 ABA Protocol Stack Requirements for ABA Space User Building Blocks

6.2.2.6.1 ABA Space User Nodes receiving framed data shall implement a forward space link communication protocol stack using compliant RF and demodulation, decoding and synchronization, and TC or AOS frame processing and multiplexing (references [34], [8], [32], [31], [9]) (figure 6-13a).

6.2.2.6.2 ABA Space User Nodes receiving reliable forward TC frames, and with RTLTL less than a few seconds, should implement the COP and FARM (reference [33], see note at 6.3.1.5.7.1).

6.2.2.6.3 ABA Space User Nodes implementing the COP FARM shall implement the CLCW as part of TC protocol processing (references [33], [31]).

6.2.2.6.4 ABA Space User Nodes implementing the COP FARM, shall insert the CLCW into the operational control field of return space link frames as part of the TM or AOS protocol (references [33], [10], [9]).

CCSDS RECOMMENDED PRACTICE FOR SPACE COMMUNICATIONS CROSS SUPPORT—
ARCHITECTURE REQUIREMENTS DOCUMENT

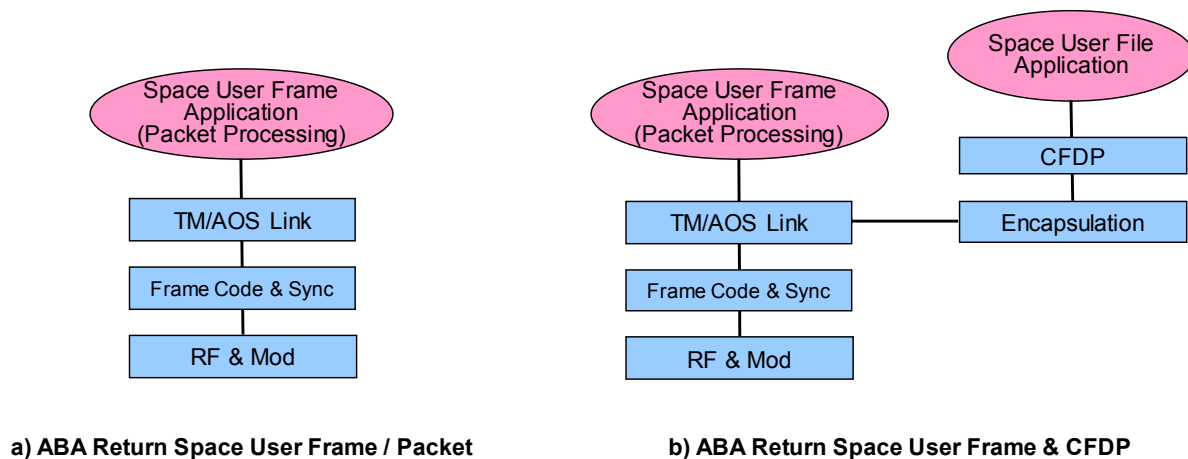

Figure 6-14: ABA Space User Return Protocol Building Blocks

6.2.2.6.5 ABA Space User Nodes receiving file data should implement a forward communication protocol stack using the forward space link, either SPP or EP encapsulation and CFDP (reference [8], [9], [14], [31], [32], [34], [39], [42]) (figure 6-13b).

6.2.2.6.6 ABA Space User Nodes may receive other application data forms by implementing a forward communication protocol stack with application protocols such as AMS (reference [41]), CFDP (reference [39]), or other, either SPP or EP encapsulation over the F-Frame space link (similar to figure 6-13b).

6.2.2.6.7 ABA Space User Nodes sending framed data shall implement a return space link communication protocol stack using TM or AOS frames, TM synchronization and coding, modulation and RF (references [10], [32], [9], [34]) (figure 6-14a).

6.2.2.6.8 ABA Space User Nodes sending near Earth high rate return data may implement a space communication protocol stack using TM or AOS frames, TM synchronization, high rate coding and modulation (reference [56] or [57]), and RF (references [10], [32], [9], [34]) (reference figure 6-14a).

NOTE – An ESLT that implements a compatible protocol stack must be used (refer to 6.2.2.1.5).

6.2.2.6.9 ABA Space User Nodes sending file data should implement a return communication protocol stack using CFDP (reference [39]), either SPP or EP encapsulation and the return space link (references [D6], [9], [10], [14], [32], [34], [42]) (figure 6-14b).

6.2.2.6.10 ABA Space User Nodes may send other application data forms by implementing a return communication protocol stack with application protocols such as AMS (reference [41]), CFDP (reference [39]), or other, either SPP or EP encapsulation, over the return space link (similar to figure 6-14b).

6.2.2.6.11 ABA Space User Nodes requiring regenerative ranging and radiometric data should implement appropriate ranging sequence recovery and (re-)generation as part of demodulation and modulation protocol processing (references [34] or [36]) (figure 6-15a).

6.2.2.6.12 ABA Space User Nodes requiring turn-around ranging and radiometric data should implement appropriate ranging processing (reference [34]) (figure 6-15b).

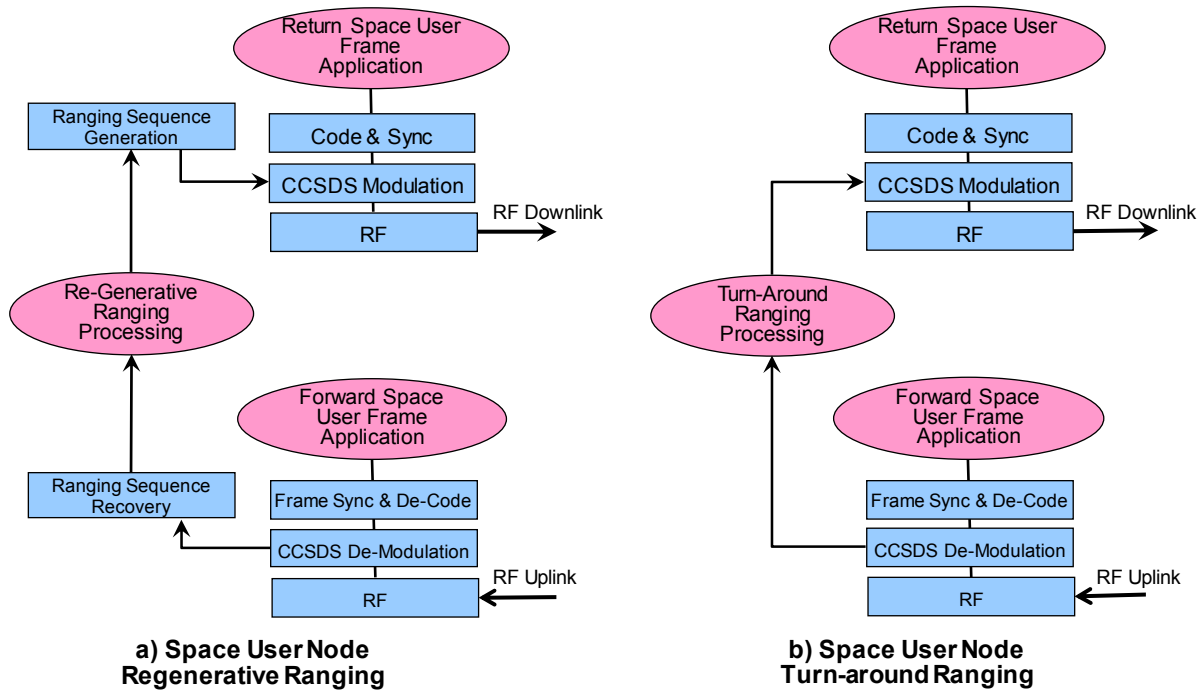

Figure 6-15: ABA Space User Ranging Protocol Building Blocks

NOTE – ABA Space User Nodes requiring ranging and radiometric data can implement appropriate ranging data processing. This might involve regenerative or turn-around ranging onboard the spacecraft. PN ranging can be employed. Proprietary tone and/or hybrid ranging systems can be used with spacecraft having a transparent ranging channel.

6.2.2.6.13 ABA Space User Nodes requiring high-precision plane-of-sky tracking data should implement DOR tone generation (reference [34]) (figure 6-16a).

NOTE – Delta-DOR operations also require recording of RF emissions from extra-galactic radio sources, i.e. Quasars (figure 6-16b).

CCSDS RECOMMENDED PRACTICE FOR SPACE COMMUNICATIONS CROSS SUPPORT—
 ARCHITECTURE REQUIREMENTS DOCUMENT

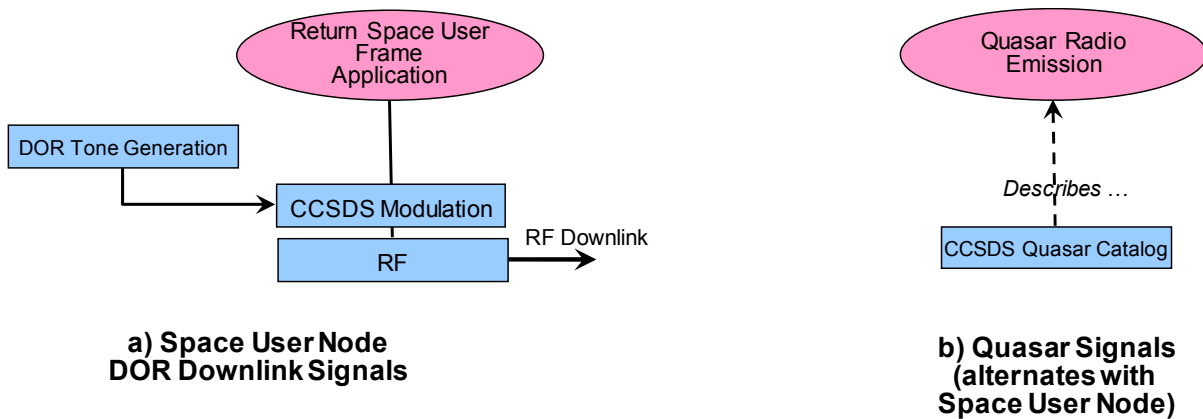

Figure 6-16: ABA Space User Delta-DOR Protocol Building Blocks

6.2.2.7 Discussion—ABA Secure Communications Protocol Recommendations

In some circumstances secure delivery of commands to a spacecraft, and secure return of data from a spacecraft, is a requirement on a mission. There are many different possible ways of doing this. What are presented in this subsection are two recommended approaches for securing the space link itself and/or the contents of the data sent over the space link. Either or both of these approaches may be applied in any of the previous configurations, using the security parts of the protocol stack configurations shown here.

Figure 6-17 shows two recommended protocol stacks for a secure ABA Earth user installation.

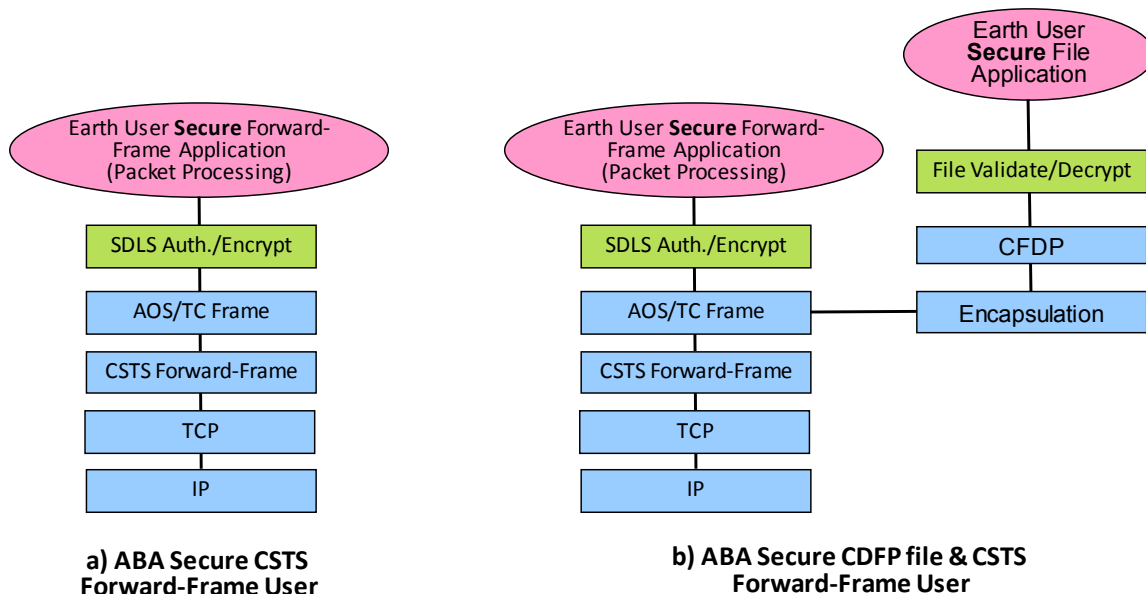

Figure 6-17: Secure ABA Earth User F-Frame and Forward-File Protocol Building Blocks

The secure frame and file methods do not require any changes in the ESLT compared to insecure communications. The entire process is handled in user space. The return path services are symmetric to the forward path services described here.

Figure 6-18 shows two recommended protocol stacks for a secure ABA space user installation.

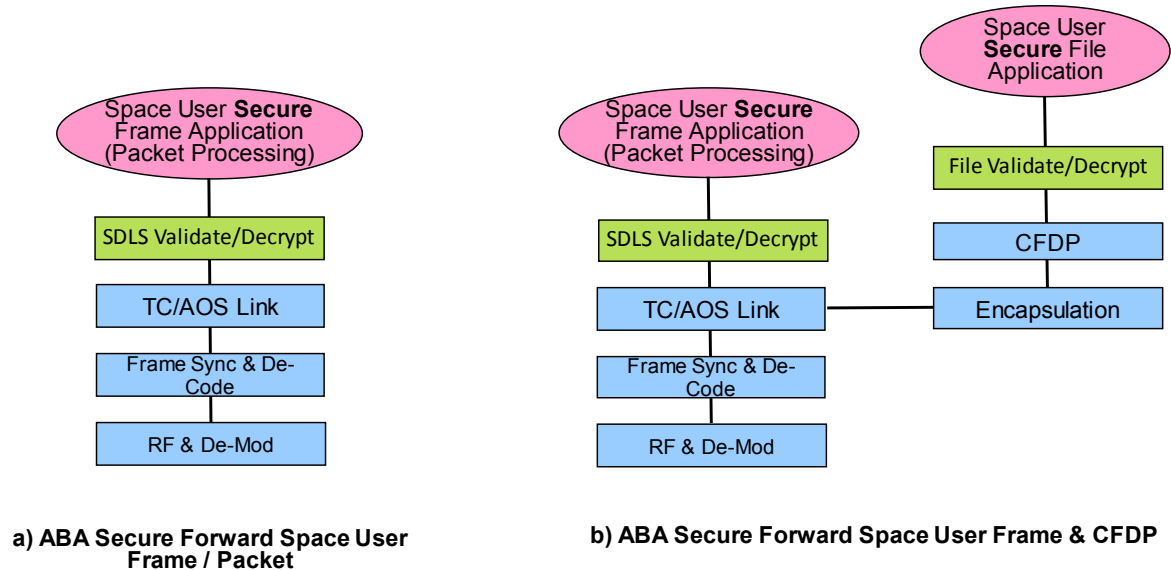

Figure 6-18: Secure ABA Space User F-Frame and Forward-File Protocol Building Blocks

6.2.2.8 ABA Protocol Stack Requirements for Earth User Node Secure ABA Protocol Building Blocks

6.2.2.8.1 ABA Earth User Nodes sending secure data may implement secure frame (Space Data Link Security [SDLS]) by itself, secure file by itself, or both, as required (references [7], [D22]).

6.2.2.8.2 ABA Earth User Nodes sending secure framed data should implement a forward communication protocol stack using a recommended authentication or authenticated encryption cryptographic algorithm and implement the SDLS protocol to insert the secure data payload into a TC or AOS frame (references [7], [D22]) (figure 6-17a).

6.2.2.8.3 ABA Earth User Nodes sending secure file data should implement a forward communication protocol stack using a recommended authentication, or authenticated encryption, algorithm to protect the file contents prior to transmission (reference [7]) (figure 6-17b).

CCSDS RECOMMENDED PRACTICE FOR SPACE COMMUNICATIONS CROSS SUPPORT—
ARCHITECTURE REQUIREMENTS DOCUMENT

6.2.2.8.4 ABA Earth User Nodes sending secure file data should implement an authentication or authenticated encryption cryptographic algorithm to secure the file (reference [7]) and either CFDP or CSTS transfer file protocol stacks to send the secured file to the ESLT providing forward services (references [D17], [39]). (See 6.2.2.3 and 6.2.2.4; see figures 6-8b or a forward version of 6-11b).

6.2.2.8.5 ABA Earth User Nodes sending secure data, either frame or file, should implement a recommended approach for key management (reference [D23]).

NOTE – The means for managing and exchanging keys is outside the scope of this document.

6.2.2.8.6 ABA Earth User Nodes receiving secure data may implement secure frame (SDLS) by itself, secure file by itself, or both, as required (references [7], [D22]), symmetric with 6.2.2.8.1.

6.2.2.9 ABA Protocol Stack Requirements for Space User Node Secure ABA Protocol Building Blocks

6.2.2.9.1 ABA Space User Nodes receiving secure data may implement secure frame (SDLS) by itself, secure file by itself, or both, as required (references [7], [D22]).

6.2.2.9.2 ABA Space User Nodes receiving secure framed data should implement a forward communication protocol stack using a recommended validation and decryption cryptographic algorithm (reference [7]) and implement the SDLS (reference [D22]) protocol to extract the secure data payload from the TC or AOS frame (references [31], [9]) (figure 6-18a).

6.2.2.9.3 ABA Space User Nodes receiving secure file data should implement a forward communication protocol stack using a recommended validation and decryption cryptographic algorithm to decrypt the file contents after reception (reference [7]) (figure 6-18b).

6.2.2.9.4 ABA Space User Nodes receiving secure data, either frame or file, should implement a recommended approach for key management (reference [D23]).

NOTE – The means for managing and exchanging keys is outside the scope of this document.

6.2.2.9.5 ABA Space User Nodes sending secure data may implement secure frame (SDLS) by itself, secure file by itself, or both, as required (references [7], [D22]), symmetric with 6.2.2.9.1.

NOTE – The secure frame and file methods do not require significant changes in the Space User Node compared to insecure communications. Implementation of the SDLS does require some modifications to the software handling the space link protocol.

6.2.3 SSI CONFIGURATION PROTOCOL BUILDING BLOCKS

6.2.3.1 Discussion

In order to provide fully compliant SSI services, the service-provider organizations must implement the additional Network Layer and support protocols in the ESLT. Similarly, any space routing nodes, PSLT, and WAN nodes must implement specific services and protocols in order to support interoperable SSI services.

While figures 6-1 and 6-10 are described as being used for ABA mission configurations, where a single-user mission ground-user MOC uses a space link to communicate with its space user asset, this same protocol-stack building block may also appear as part of an SSI configuration. In the SSI case, the Earth relay node (space relay node MOC) may use the protocol stack shown in figure 6-1c to form the forward link to the space relay node, and may use the one shown in figure 6-10 to do the planning.

In this section the use of DTN for SSI deployments is assumed. The rationale is that while IP deployments (reference [IPS]) will work in certain limited operating environments, the DTN deployments (reference [DTN]) will work in all space environments. Aside from the lack of any sort of store and forward capability in (reference [IPS]), there is a straightforward substitution of IP protocols for BP and LTP in these figures. As documented in section 5, SSI nodes with intermittent link connectivity, BDP $>10^7$, or long RTLTs (>2 seconds) should implement the basic DTN internetworking functions (reference [DTN]). SSI nodes with continuous link connectivity, BDP $<10^7$, and short RTLTs may implement the basic IP internetworking functions (reference [IPS]).

Both IPS and DTN utilize an Encapsulation ‘shim’ layer [14] to insert their PDUs into CCSDS link layer protocols. Where other link layer protocols are used, such as WiFi, or where DTN is run as an overlay network on top of IPS, a Convergence Layer Adapter (CLA) is employed. (See BP, reference [12], for details.)

6.2.3.2 Future SSI ESLT Service-Provider Protocol Recommendations

6.2.3.2.1 Overview

SSI ESLTs implement all of the protocols that an ABA ESLT does, and also implement the additional protocols for handling DTN and IP data traffic. Providing SSI services requires location of a DTN routing agent and/or IP router in the ESLT and implementing frame creation, merging, encoding, and related protocols in the ESLT.

6.2.3.2.2 Requirements

6.2.3.2.2.1 [Future] SSI ESLTs shall implement all of the forward communication protocol stack features of required of an ABA ESLT, as specified in 6.2.1.2 (figure 6-19a).

CCSDS RECOMMENDED PRACTICE FOR SPACE COMMUNICATIONS CROSS SUPPORT—
ARCHITECTURE REQUIREMENTS DOCUMENT

6.2.3.2.2.2 [Future] SSI ESLTs shall implement all of the return communication protocol stack features of required of an ABA ESLT, as specified in 6.2.1.2 (symmetric to figure 6-19a).

NOTE – A fully configured SSI ESLT is also capable of supporting all ABA users.

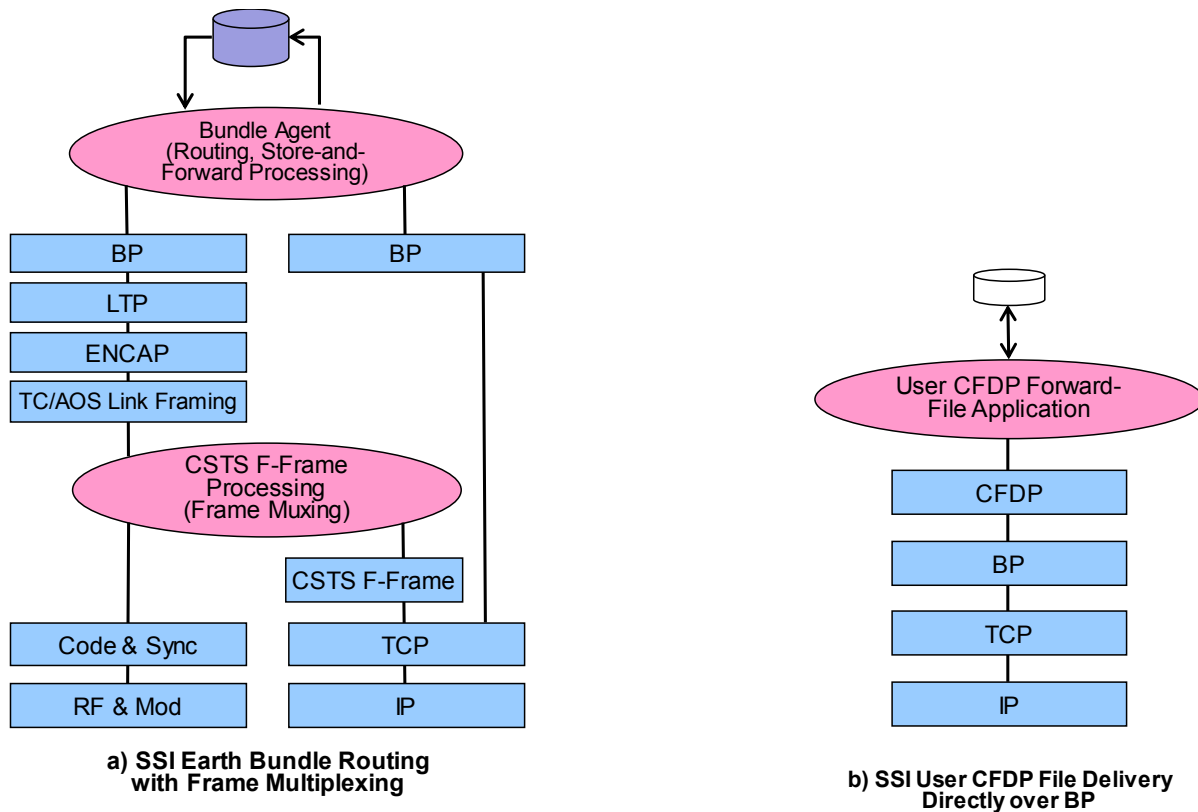

Figure 6-19: SSI ESLT and User DTN Protocol Building Blocks

6.2.3.2.2.3 [Future] SSI ESLTs transporting DTN data shall implement a forward communication protocol stack using the CSTS F-Frame provider agent (reference [D14]) and a DTN bundle agent (reference [DTN]).

6.2.3.2.2.4 [Future] The BP (reference [12]), LTP (reference [13]), encapsulation (reference [14]), AOS or TC frame creation, and frame merging protocols (references [9] or [31]) shall all be implemented in the ESLT (figure 6-19a).

6.2.3.2.2.5 [Future] SSI ESLTs transporting DTN data shall implement a return communication protocol stack using a DTN bundle agent (reference [DTN]) and the SLE RCF provider agent (reference [23]).

6.2.3.2.2.6 [Future] The AOS or TM frame processing, frame de-multiplexing, de-capsulation (reference [9] or [10], [14]), LTP (reference [13]), and BP (reference [12]) shall all be implemented in the ESLT (symmetric to figure 6-19a).

6.2.3.2.2.7 [Future] SSI ESLTs transporting IP data shall implement a forward communication protocol stack using the CSTS F-Frame provider agent (reference [D14]) and an IP router (reference [IPS]).

6.2.3.2.2.8 [Future] The IP (references [46], [47]), encapsulation (reference [14]), AOS or TC frame creation, and frame merging protocols (references [9] or [31]) shall all be implemented in the ESLT (similar to figure 6-19a).

6.2.3.2.2.9 [Future] SSI ESLTs transporting IP data shall implement a return communication protocol stack using an IP router (reference [IPS]) and the SLE RCF provider agent (reference [23]).

6.2.3.2.2.10 [Future] The AOS or TM frame processing, frame de-multiplexing, decapsulation (references [9] or [10], [14]), LTP (reference [13]), and IP (references [46], [47]) shall all be implemented in the ESLT (similar to figure 6-19a).

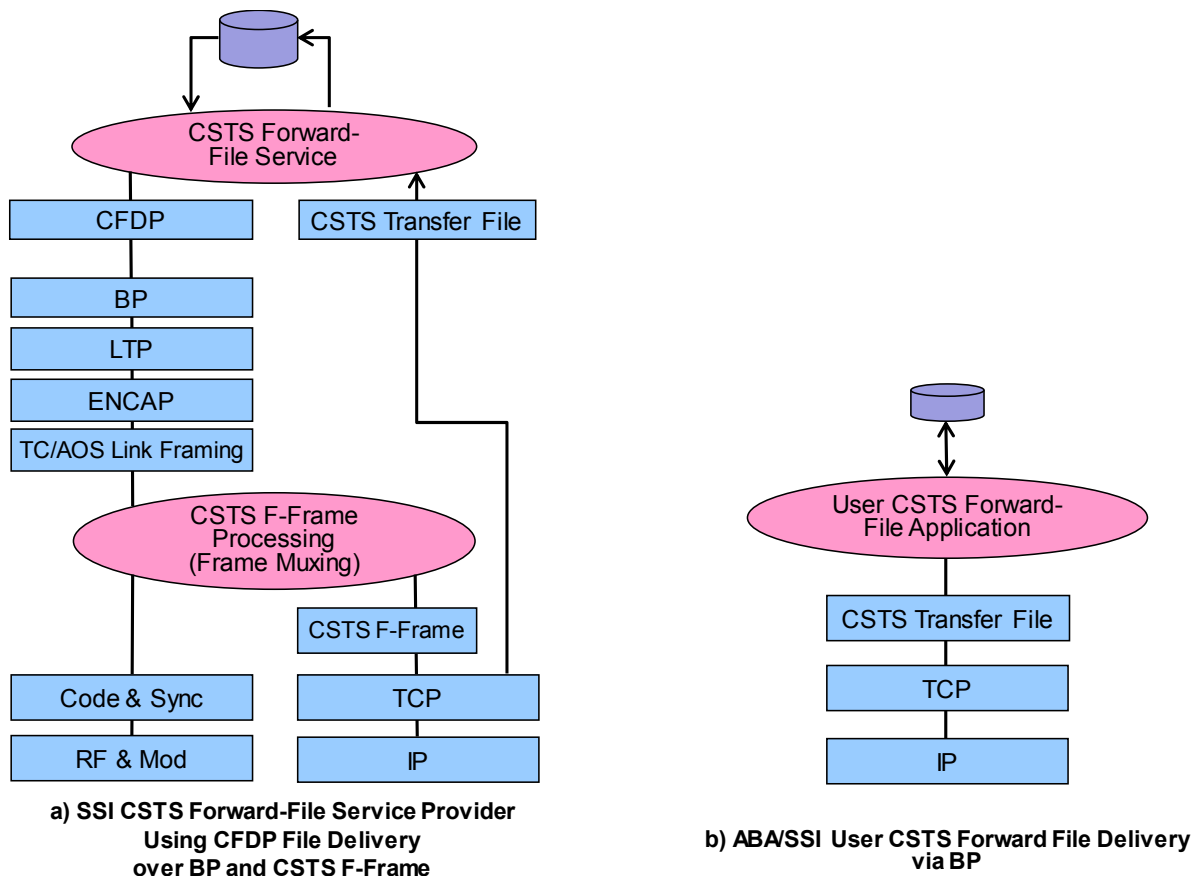

Figure 6-20: SSI ESLT and User DTN Forward-File Building Blocks

6.2.3.2.2.11 [Future] SSI ESLTs providing a forward-file service shall implement a forward-communication protocol stack using a CSTS transfer file protocol (reference [D17]). The CSTS forward-file service, the CFDP protocol (reference [39]), and the other forward DTN protocols are implemented in the ESLT (figure 6-20a).

CCSDS RECOMMENDED PRACTICE FOR SPACE COMMUNICATIONS CROSS SUPPORT—
ARCHITECTURE REQUIREMENTS DOCUMENT

6.2.3.2.2.12 [Future] SSI ESLTs providing a return file service shall implement a return communication protocol stack using a CSTS transfer file protocol (reference [D17]), the CSTS return-file service, the CFDP protocol (reference [39]), and the other return DTN protocols that are implemented in the ESLT (symmetric to figure 6-20a).

6.2.3.2.2.13 [Future] All SSI ESLTs providing CCSDS-compliant cross support services shall implement the extensible CCSDS service management protocols (reference [D10]) over HTTPS (references [50], [55]) and TCP/IP (references [47], [48]) (figure 6-21a, b).

6.2.3.2.2.14 [Future] SSI ESLTs providing CCSDS-compliant cross support services shall implement the extensible CCSDS service management protocol (reference [D10]) to provide users with the means to securely schedule and configure space communications and internetworking services (figure 6-21a).

6.2.3.2.2.15 [Future] SSI ESLTs providing CCSDS-compliant cross support services shall accept NDM (reference [29]) or ODM (reference [30]) files transferred within the extensible CCSDS service management protocol (reference [D10]) to provide spacecraft trajectory or orbit data (figure 6-21b).

6.2.3.2.2.16 [Future] SSI ESLTs providing CCSDS-compliant cross support services should implement the extensible CCSDS network schedule interface (reference [D10]) to identify the expected times for scheduled space communications and internetworking services (figure 6-21a).

6.2.3.2.2.17 [Future] SSI ESLTs providing CCSDS-compliant cross support services should implement the extensible CCSDS service-agreement interface (reference [D10]) to define and arrange for delivery of space communications and internetworking services (figure 6-21a).

6.2.3.2.2.18 [Future] SSI ESLTs providing CCSDS-compliant cross support services should implement the extensible CCSDS service accountability interface (reference [D10]) to request and accept delivery of service accountability reports (figure 6-21a).

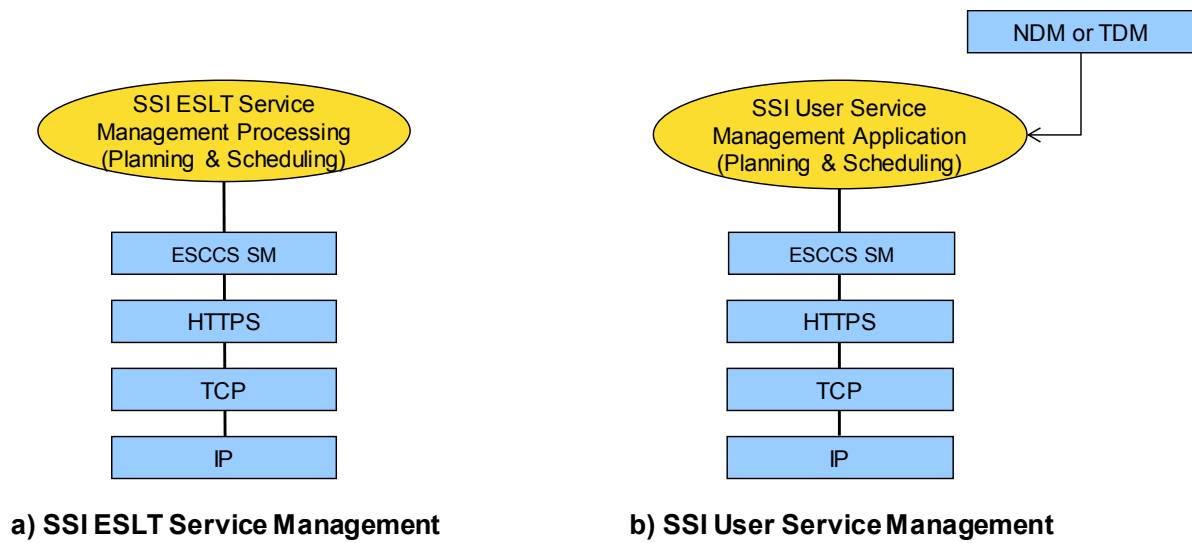

Figure 6-21: SSI ESLT and User Service Management Building Blocks

6.2.3.2.2.19 [Future] SSI ESLT nodes providing CCSDS-compliant cross support services should implement the DTN network management protocol (reference [D12]) over BP (reference [12]) to configure and manage the SSI ESLT services (figure 6-23a).

6.2.3.2.2.20 [Future] SSI ESLT nodes providing cross support services should implement the SSI NSAs and PAs (reference [D7]) over HTTPS (reference [55]) to plan, schedule, and coordinate the SSI ESLT services (figure 6-23b).

6.2.3.3 Future SSI Space Routing Node Service-Provider Protocol Recommendations

6.2.3.3.1 Overview

SSI space routing nodes implement full SSI services for storing and forwarding user data. The protocols that must be supported include those for long-haul space links as well as those for nearby/proximity links.

6.2.3.3.2 Requirements

6.2.3.3.2.1 [Future] SSI space routing nodes shall implement all of the forward communication protocol stack features required of an ABA Space User Node, as specified in 6.2.2.5 (figure 6-22b).

6.2.3.3.2.2 [Future] SSI space routing nodes shall implement all of the return communication protocol stack features required of an ABA Space User Node, as specified in 6.2.2.5 (symmetric to figure 6-22b).

CCSDS RECOMMENDED PRACTICE FOR SPACE COMMUNICATIONS CROSS SUPPORT—
 ARCHITECTURE REQUIREMENTS DOCUMENT

6.2.3.3.2.3 [Future] SSI space routing nodes shall provide a forward and return communications protocol stack including the DTN BP (reference [12]) and related S&F functions (figure 6-22b).

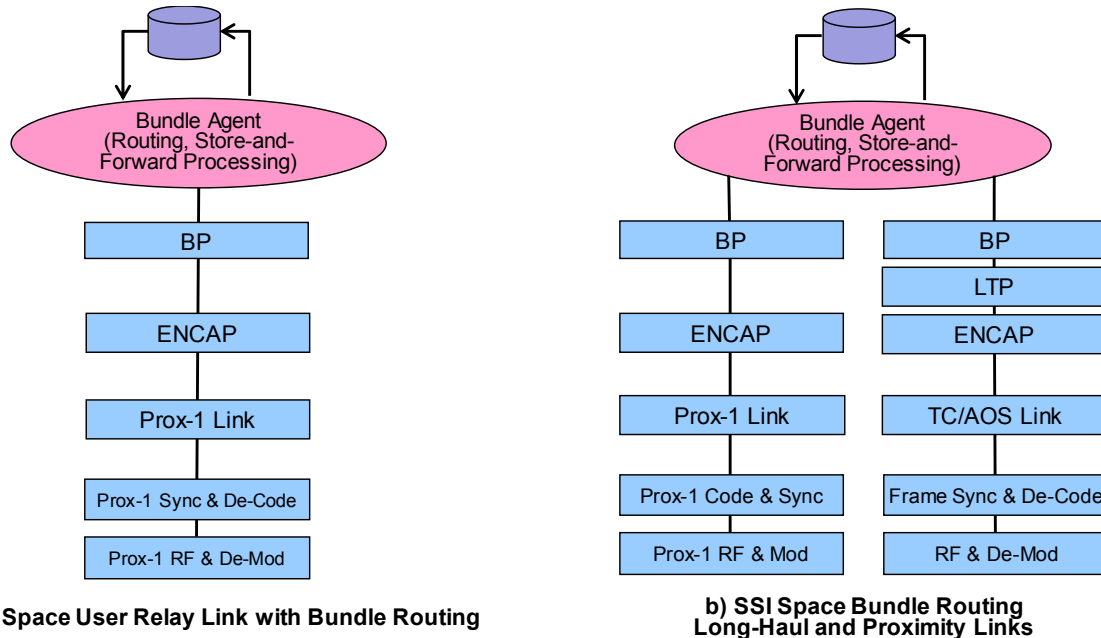

Figure 6-22: SSI Space User and Routing Node DTN Protocol Building Blocks

6.2.3.3.2.4 [Future] SSI space routing nodes supporting long-haul links shall provide a communications protocol stack that includes the BP (reference [12]), LTP (reference [13]), encapsulation (reference [14]), AOS (reference [9]) or TM (reference [10]) frame creation, frame merging, and coding and synchronization protocols (reference [32] or [7]) (figure 6-22b).

6.2.3.3.2.5 [Future] SSI space routing nodes supporting proximity links shall provide a communications protocol stack that includes the BP (reference [12]), encapsulation (reference [14]), Proximity-1 frame creation, coding and synchronization protocols (references [43], [44], [45]) (figure 6-22b).

NOTE – These two requirements (6.2.3.3.2.4 and 6.2.3.3.2.5) include dedicated or hybrid/science routing nodes in space as well as a PSLT located on a planet surface. Reference functions defined in 5.3.2.3, 5.3.3, and 5.3.7.

6.2.3.3.2.6 [Future] SSI space routing nodes supporting hardwired or terrestrial WiFi-style Local Area Network (LAN) links shall provide a communications protocol stack that includes the BP (reference [12]), and frame protocols appropriate for the local LAN environment (TBD) (figure 6-28b).

NOTE – This includes WAN/LAN routing nodes on Earth or located on a planet surface. Reference functions defined in 5.3.3.3.

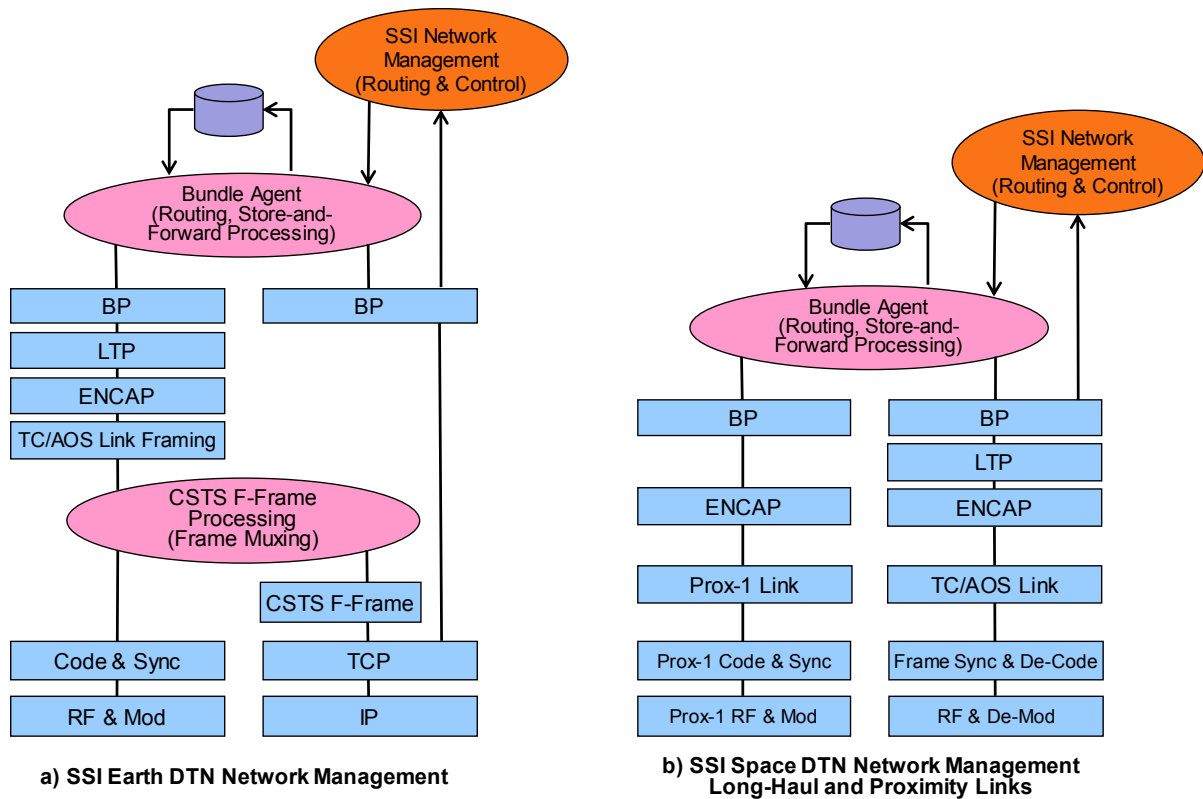

Figure 6-23: SSI ESLT and Space Routing DTN Network Management Building Blocks

6.2.3.3.2.7 [Future] SSI space routing nodes providing cross support services should implement the DTN network management protocol (reference [D12]) over BP (reference [12]) to configure and manage the SSI services (figure 6-23b).

6.2.3.3.2.8 [Future] SSI space routing nodes providing cross support services should implement the SSI NSAs and PAs (reference [D7]) over BP (reference [12]) to plan, schedule, and coordinate the SSI services (figure 6-23b).

6.2.3.4 Future SSI Earth Routing Node Service-Provider Protocol Recommendations

6.2.3.4.1 Overview

SSI Earth routing nodes (space routing node MOCs) are responsible for operating one or more space routing nodes or PSLTs. They nominally use ABA-style link layer services to control the space routing assets that they manage. They may themselves offer SSI routing services, but this is not required.

CCSDS RECOMMENDED PRACTICE FOR SPACE COMMUNICATIONS CROSS SUPPORT—
 ARCHITECTURE REQUIREMENTS DOCUMENT

6.2.3.4.2 Requirements

6.2.3.4.2.1 [Future] SSI Earth routing nodes (space routing node MOCs) shall implement all of the protocols required of an ABA Earth User Node (6.2.2.3).

6.2.3.4.2.2 [Future] SSI Earth routing nodes may provide a forward and return communications protocol stack including the DTN BP (reference [12]) and related S&F functions (figure 6-24b).

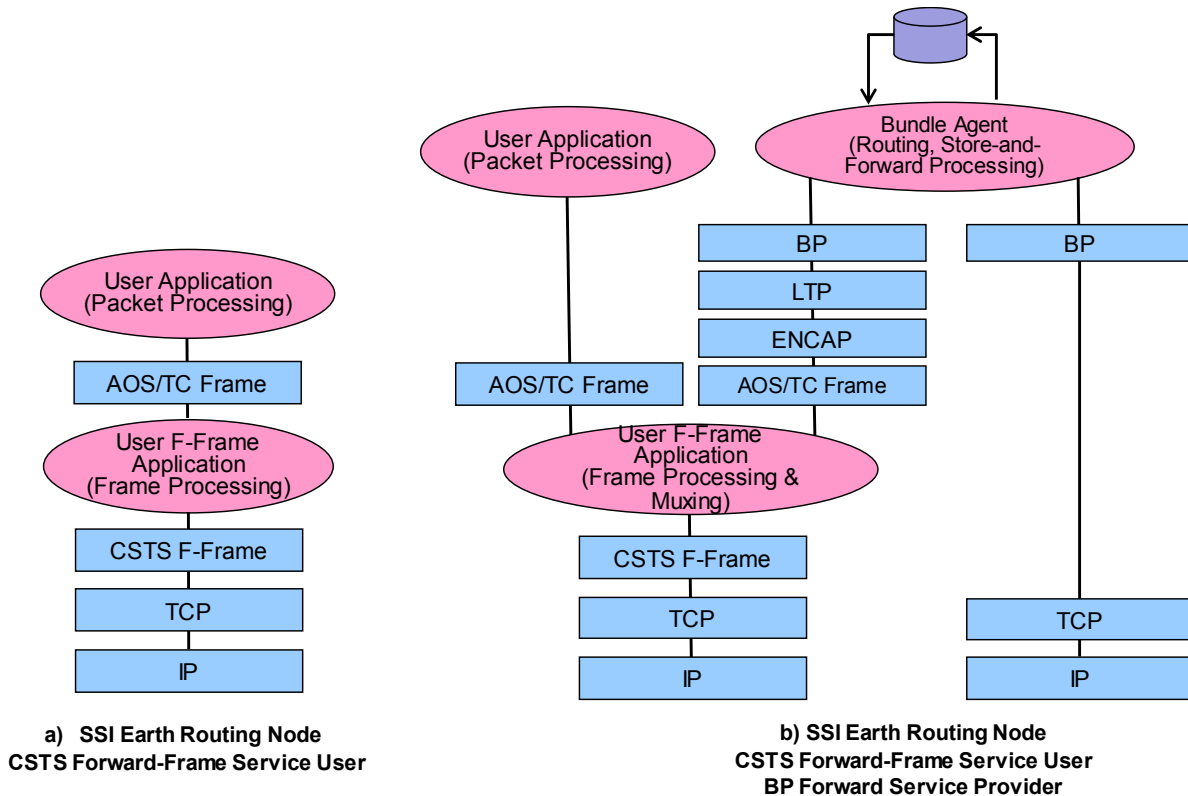

Figure 6-24: SSI Earth Routing Node Forward Building Blocks

6.2.3.4.2.3 [Future] SSI Earth routing nodes (space routing node MOCs) shall implement one or more CCSDS-compliant space link protocols, TC, TM, or AOS (references [8], [10], or [9]) (figure 6-10a or b and 6-11a).

6.2.3.4.2.4 [Future] SSI Earth routing nodes (space routing node MOCs) shall implement spacecraft TT&C forward and return communication protocol stack for AOS, TC, and TM using the CSTS F-Frame and SLE RAF or RCF user clients (references [22] or [23]) (figures 6-10b, 6-11b, and 6-24a).

6.2.3.4.2.5 [Future] SSI Earth routing nodes (space routing node MOCs) transporting DTN and either AOS or TC data should implement a forward communication protocol stack using the CSTS F-Frame user client agent (reference [D14]) and a DTN bundle agent (reference [DTN]) (figure 6-24b).

6.2.3.4.2.6 [Future] SSI Earth routing nodes (space routing node MOCs) transporting DTN and either AOS or TM data should implement a return communication protocol stack using the SLE RAF or RCF user clients (reference [22] or [23]) and a DTN bundle agent (reference [DTN]) (figure 6-25).

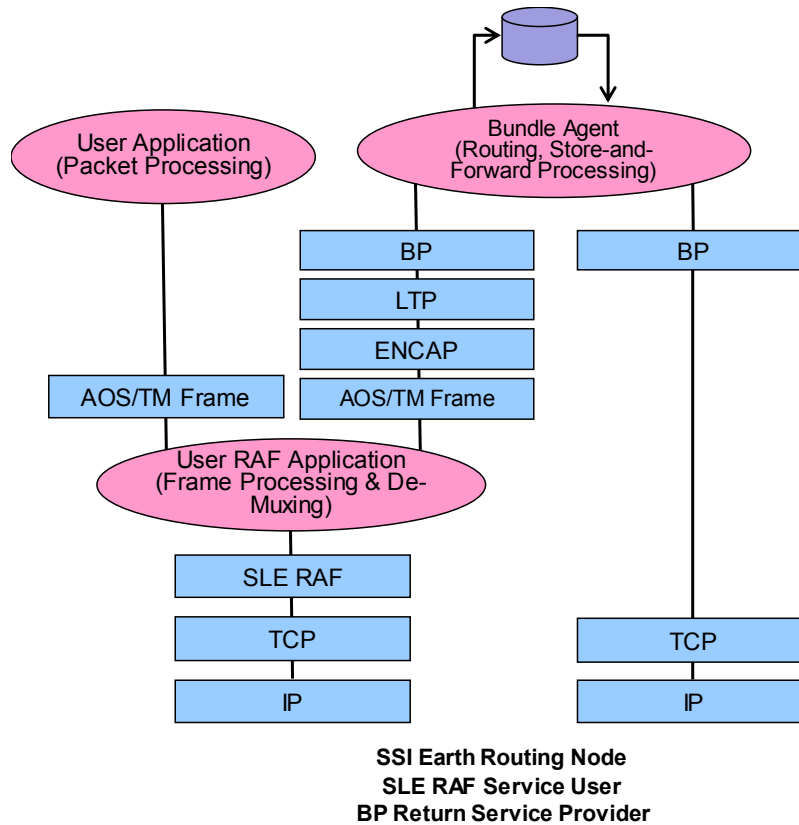

Figure 6-25: SSI Earth Routing Node Return Building Block

6.2.3.4.2.7 [Future] SSI Earth routing nodes may send other application data forms by implementing a forward or return communication protocol stack with application protocols such as AMS (reference [41]) (or other), either SPP or EP encapsulation, over the BP (reference [12]) (similar to figure 6-19b).

6.2.3.4.2.8 [Future] SSI Earth routing nodes providing cross support services should implement the DTN network-management protocol (reference [D12]) over BP (reference [12]) to configure and manage the SSI services (similar to figure 6-23b).

6.2.3.4.2.9 [Future] SSI Earth routing nodes providing cross support services should implement the SSI NSAs and PAs (reference [D7]) over HTTPS (reference [55]) to plan, schedule, and coordinate the SSI services (figure 6-21b).

NOTE – For SSI Stage 1 deployments, prior to the existence of SSI ESLTs, SSI Earth routing nodes may be configured as shown in figures 6-24b and 6-25 to offer SSI services to other SSI user nodes.

CCSDS RECOMMENDED PRACTICE FOR SPACE COMMUNICATIONS CROSS SUPPORT—
ARCHITECTURE REQUIREMENTS DOCUMENT

6.2.3.5 Future SSI Earth User Node Protocol Recommendations

6.2.3.5.1 [Future] SSI Earth routing nodes shall provide a forward and return communications protocol stack including the DTN BP (reference [12]) and related S&F functions (figure 6-26b).

6.2.3.5.2 [Future] SSI Earth User Nodes transporting mission data should implement a forward and return communication protocol stack using mission-specific data structures encapsulated in ENCAP or SPP packets (references [14], [42]) transported using the DTN BP (reference [12]) (figure 6-26a).

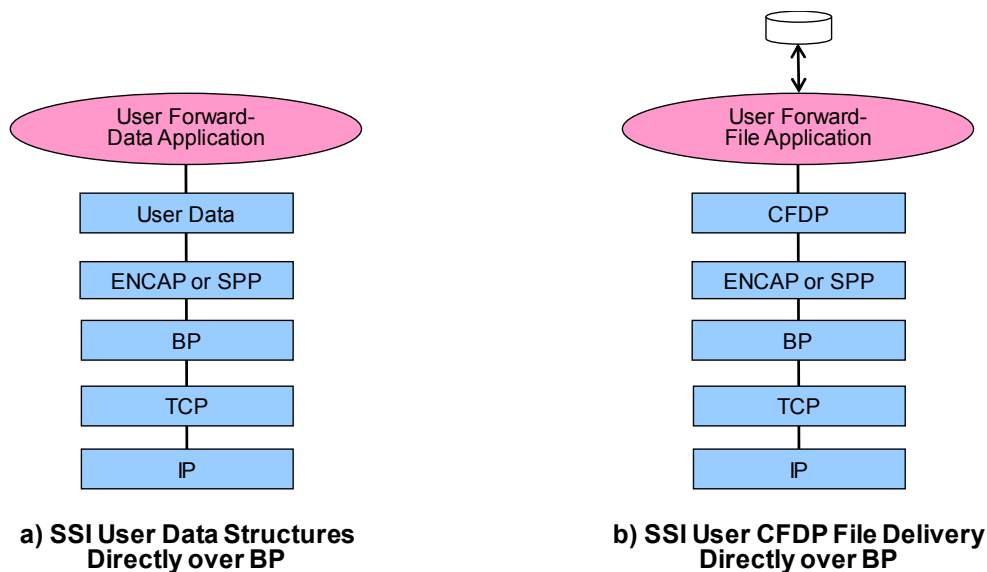

Figure 6-26: SSI Earth User Node DTN Forward Building Blocks

6.2.3.5.3 [Future] SSI Earth User Nodes transporting mission data as files should implement a forward and return communication protocol stack putting mission specific data structures in files and transporting them using CFDP (reference [39]) and the DTN BP (reference [12]) (figure 6-26b).

6.2.3.5.4 [Future] SSI Earth User Nodes transporting mission data as messages should implement a forward and return communication protocol stack putting mission specific data structures encapsulated in messages and transporting them using AMS (reference [41]) and the DTN BP (reference [12]) (similar to figure 6-26b).

6.2.3.5.5 [Future] Earth User Nodes requiring CCSDS-compliant cross support services shall implement the extensible CCSDS service management protocol (reference [D10]) to securely schedule and configure space communications and internetworking services (figure 6-21b).

6.2.3.5.6 [Future] Earth User Nodes requiring CCSDS-compliant cross support services shall transfer NDM (reference [29]) or ODM (reference [30]) files within the extensible CCSDS service management protocol (reference [D10]) to provide spacecraft trajectory or orbit data (figure 6-21b).

6.2.3.5.7 [Future] Earth User Nodes requiring CCSDS-compliant cross support services should implement the extensible CCSDS network schedule interface (reference [D10]) to identify the expected times for scheduled space communications and internetworking services (figure 6-21b).

6.2.3.5.8 [Future] Earth User Nodes requiring CCSDS-compliant cross support services should implement the extensible CCSDS service-agreement interface (reference [D10]) to define and request delivery of space communications and internetworking services (figure 6-21b).

6.2.3.5.9 [Future] SSI Earth User Nodes requesting cross support services may implement the DTN network-management protocol (references [D7], [D12]) over HTTPS (reference [55]) to configure and manage the SSI services (similar to figure 6-21b).

6.2.3.5.10 [Future] SSI Earth User Nodes providing cross support services should implement the SSI NSAs and PAs (reference [D7]) over HTTPS (reference [55]) to plan, schedule, and coordinate the SSI services (similar to figure 6-21b).

6.2.3.6 Future SSI Space User Node Protocol Recommendations

6.2.3.6.1 [Future] SSI Space User Nodes shall provide a forward and return communications protocol stack including the DTN BP (reference [12]) and related S&F functions (figure 6-27a).

6.2.3.6.2 [Future] SSI Space User Nodes using long-haul links shall provide a communications protocol stack that includes the basic BP (reference [12]), LTP (reference [13]), encapsulation (reference [14]), AOS, TC, and/or TM frame creation, coding and synchronization protocols (references [9], [31], and/or [10]) (figure 6-27a).

6.2.3.6.3 [Future] SSI Space User Nodes using proximity links shall provide a communications protocol stack that includes the basic BP (reference [12]), encapsulation (reference [14]), Proximity-1 frame creation, coding and synchronization protocols (reference [43], [44], [45]) (figure 6-27b).

CCSDS RECOMMENDED PRACTICE FOR SPACE COMMUNICATIONS CROSS SUPPORT—
 ARCHITECTURE REQUIREMENTS DOCUMENT

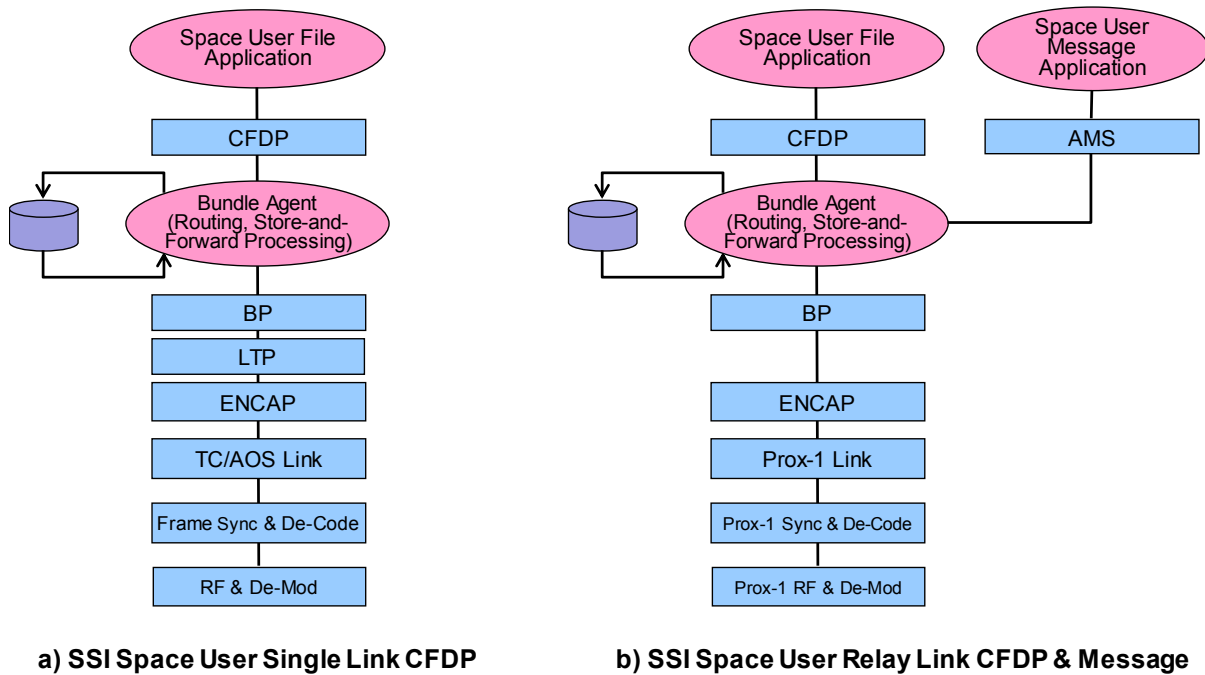

Figure 6-27: SSI Space User DTN Forward-File Building Blocks

6.2.3.6.4 [Future] SSI Space User Nodes using hardwired or terrestrial WiFi-style LAN links shall provide a communications protocol stack that includes the basic BP (reference [12]), and frame protocols appropriate for the local LAN environment (TBD) (figure 6-28a).

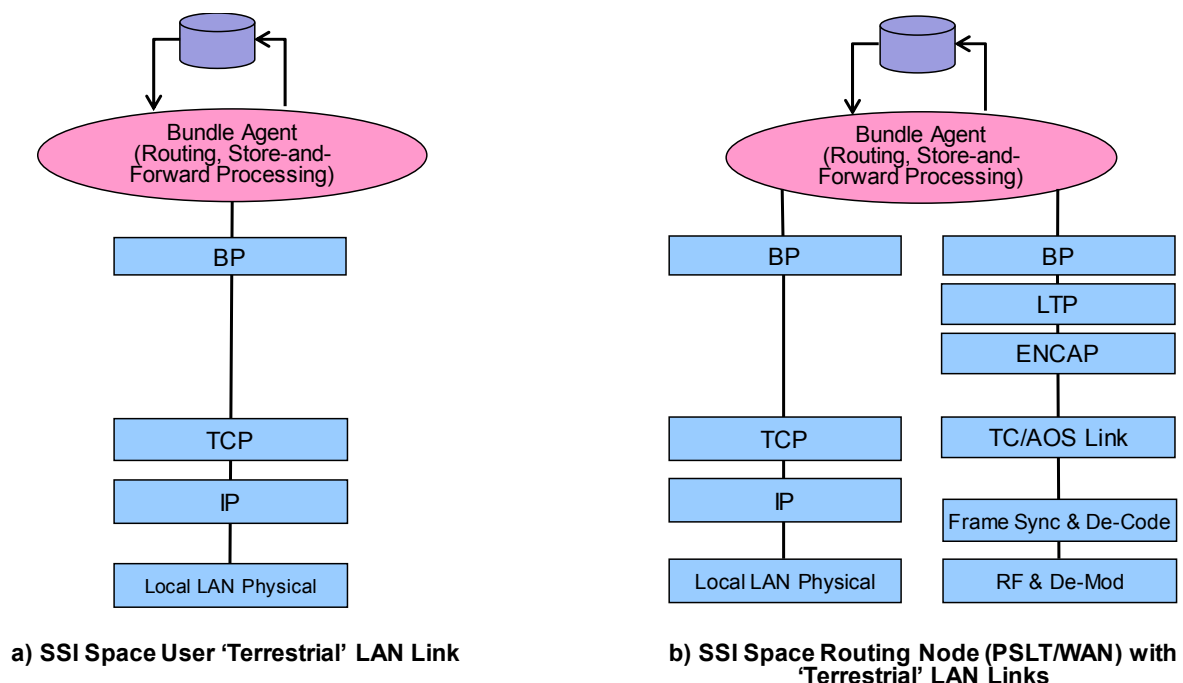

Figure 6-28: SSI Space User and Routing Node Local LAN Building Blocks

6.2.3.7 Future SSI Secure Communications Protocol Recommendations

6.2.3.7.1 Discussion

In SSI configurations, users may apply encryption directly to their data, but Network Layer security may also be employed. Because an internetworked space architecture allows user data to be forwarded (possibly through multiple hops), and because of the intrinsic value of both space assets and communication opportunities, care needs to be taken to ensure that only authorized traffic is allowed onto the SSI.

For IP configuration, it is important to keep in mind that using IP in the SSI does not necessarily mean connecting the SSI to the Internet at large. The SSI can use a private IP address space that is not routable on the Internet and/or Virtual Private Network (VPN). It is also possible to use IPSec protocols on the ground.

Figures 6-29 and 6-30, in aggregate, show three alternative approaches for securing an SSI end-to-end file transfer. The SSI user MOC may apply one of the encryption or authentication algorithms to its command data and load that into a file. The secured file, in and of itself, provides end-to-end data security. That secured file may be transferred using CFDP, secured by the SBSP, and loaded into BP bundles (or IP datagrams). BP/SBSP may then use IPSec and TCP/IP to transmit the data to the ESLT, as shown in figure 6-29, and thence to the Space User Node (references [D25] and [6]). As opposed to this example typically only one security approach will be used at any given time. While these examples show three different approaches to securing data and its transmission, most often only one of these security approaches will be used at any given time.

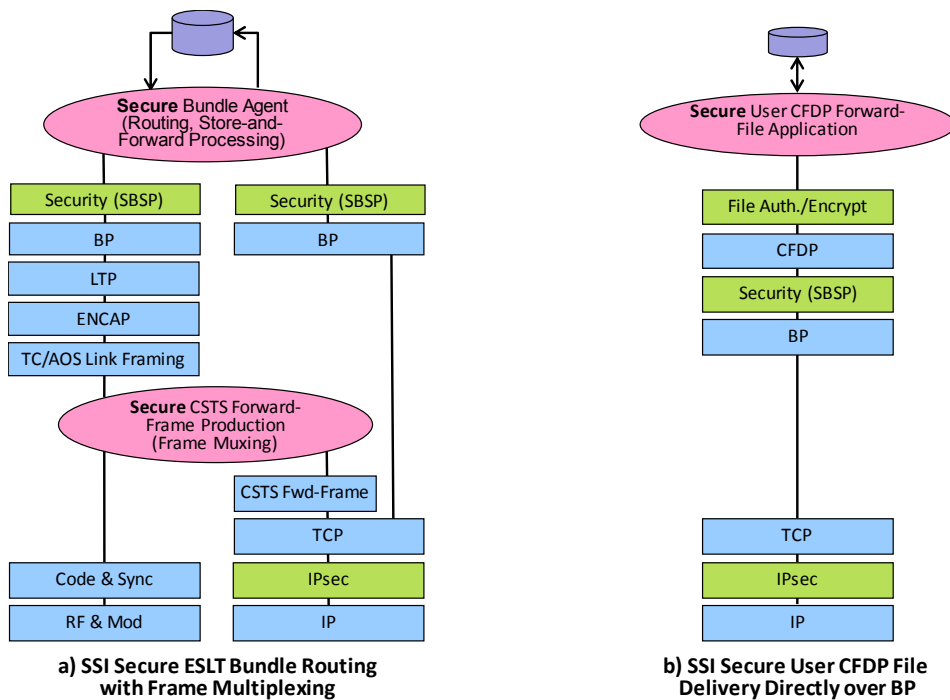

Figure 6-29: SSI Secure Forward-File Building Blocks

CCSDS RECOMMENDED PRACTICE FOR SPACE COMMUNICATIONS CROSS SUPPORT—
ARCHITECTURE REQUIREMENTS DOCUMENT

6.2.3.7.2 Requirements

6.2.3.7.2.1 [Future] SSI Earth User Nodes sending secure file data should implement a forward communication protocol stack using a recommended authentication, or authenticated encryption, algorithm (reference [7]) to protect the file contents prior to transmission (figure 6-29b).

6.2.3.7.2.2 [Future] SSI Earth User Nodes sending secure data may implement the SBSP (reference [D26]) to secure any transmitted DTN bundles, as required (figure 6-29b).

6.2.3.7.2.3 [Future] SSI Earth User Nodes sending secure data may implement the IPSec (reference [53], [54]) to secure all terrestrial IP network traffic, as agreed with the SSI ESLT providing service (figure 6-29b).

6.2.3.7.2.4 [Future] SSI Earth User Nodes sending secure data, bundle, frame or file, should implement a recommended approach for key management (reference [D23]).

NOTE – The means for managing and exchanging keys is outside the scope of this document.

6.2.3.7.2.5 [Future] SSI Earth User Nodes receiving secure data, either frame or file, should implement the required symmetric return versions of the security protocol stacks.

6.2.3.7.2.6 [Future] SSI ESLTs transporting secure data should implement the SBSP (reference [D26]) to secure any transmitted DTN bundles, as required (figure 6-29a).

6.2.3.7.2.7 [Future] SSI ESLTs transporting secure data may implement the IPSec (reference [53], [54]) to secure all terrestrial IP network traffic, as agreed with the SSI Earth User Nodes requesting service (figure 6-29a).

6.2.3.7.2.8 [Future] SSI ESLTs transporting secure data, bundle, frame or file, must implement a recommended approach for key management (reference [D23]).

NOTE – The means for managing and exchanging keys is outside the scope of this document.

6.2.3.7.2.9 [Future] SSI ESLTs transporting secure framed data may implement a forward communication protocol stack using a recommended authentication or authenticated encryption cryptographic algorithm and implement the SDLS protocol to insert the secure data payload into a TC or AOS frame. (reference [7], [D22]) (like figure 6-17a).

NOTES

- 1 The secure frame method may be applied between the space relay node and the Earth relay node (space relay node MOC). If the SSI ESLT applies SDLS security, then the security association is between the SSI ESLT and the SSI space relay node. Presumably the SSI Earth relay node will retain management of the keys.

Implementation of the SDLS does require some modifications to the software handling the space link protocol.

- 2 The user spacecraft must implement the symmetrical authentication/encryption functions to process the received data contents of the file and any SBSP-applied security. The presence of the BP/SBSP security mechanisms that are in use are signaled. Some means must also be provided to establish and manage the keys used to protect or sign the data and to signal any changes to the spacecraft. Any intermediate routing node also participates in the SBSP protocol, but the use of any user-applied security is invisible to these intermediate nodes.

6.2.3.7.2.10 [Future] SSI Space User Nodes receiving secure file data should implement a forward communication protocol stack using a recommended authentication, or authenticated encryption, algorithm (reference [7]) to recover the file contents prior after reception (figure 6-30a).

6.2.3.7.2.11 [Future] SSI Space User Nodes receiving secure data may implement the SBSP (reference [D26]) to recover any received DTN bundles (figure 6-30a).

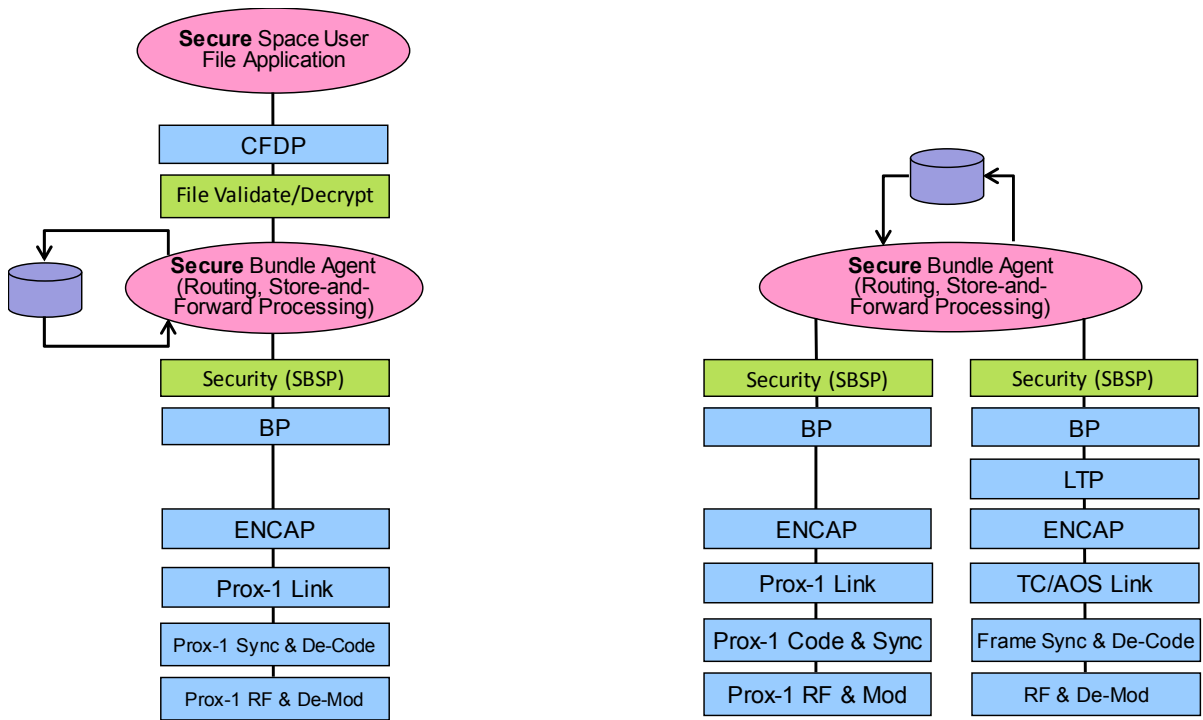

**a) SSI Secure Space User Node
 Proximity Link with Bundle Routing**

**b) SSI Secure Space Routing Node
 Long-Haul and Proximity Links**

Figure 6-30: SSI Secure Space User and Space Routing Node Building Blocks

CCSDS RECOMMENDED PRACTICE FOR SPACE COMMUNICATIONS CROSS SUPPORT—
ARCHITECTURE REQUIREMENTS DOCUMENT

6.2.3.7.2.12 [Future] SSI Space User Nodes receiving secure data, bundle, frame or file, must implement a recommended approach for key management (reference [D23]).

NOTE – The means for managing and exchanging keys is outside the scope of this document.

6.2.3.7.2.13 [Future] SSI Space User Nodes receiving secure framed data should implement a forward communication protocol stack using a recommended validation and decryption cryptographic algorithm (reference [7]) and implement the SDLS (reference [D22]) protocol to extract the secure data payload from the TC or AOS frame (reference [31], [9]) (figure 6-18a).

6.2.3.7.2.14 [Future] SSI Space User Nodes sending secure data, bundle, frame, or file, should implement the required symmetric return versions of the security protocol stacks.

NOTE – The secure frame and file methods do not require significant changes in the Space User Node compared to insecure communications. Implementation of the SDLS does require some modifications to the software handling the space link protocol.

6.2.3.7.2.15 [Future] SSI space routing nodes receiving secure data shall implement the SBSP (reference [D26]) to recover any DTN bundles received from other nodes (figure 6-30b).

6.2.3.7.2.16 [Future] SSI space routing nodes sending secure data shall implement the SBSP (reference [D26]) to deliver any received DTN bundles to other nodes (figure 6-30b).

6.2.3.7.2.17 [Future] SSI space routing nodes receiving secure data, bundle, frame or file, must implement a recommended approach for key management (reference [D23]).

NOTE – The means for managing and exchanging keys is outside the scope of this document.

6.2.3.7.2.18 [Future] SSI space routing nodes receiving secure framed data should implement a forward communication protocol stack using a recommended validation and decryption cryptographic algorithm (reference [7]) and implement the SDLS (reference [D22]) protocol to extract the secure data payload from the TC or AOS frame (reference [31], [9]) (like figure 6-18a).

6.2.3.7.2.19 [Future] SSI space routing nodes sending secure data, either frame or file, should implement the required symmetric return versions of the security protocol stacks.

6.2.4 SSI LAST-HOP AND FIRST-HOP SERVICE

6.2.4.1 Overview

Not all nodes in any given SSI deployment will be fully SSI capable. Furthermore, even SSI-capable nodes may need to be rebooted, commanded, and/or controlled at the link layer in the event of emergencies or failure of the SSI components. The last-hop and first-hop services provide the capabilities to perform all of these different functions for ABA terminal nodes or SSI nodes when they need such services. Last-hop and first-hop delivery agents are shown deployed in space routing nodes; they may also be deployed in an ESLT as well, but this is not required.

6.2.4.2 Future SSI Last-Hop and First-Hop Service Requirements

6.2.4.2.1 [Future] SSI space routing nodes supporting end-user SSI nodes and non-SSI (ABA) nodes shall implement the last-hop delivery functions (references [D5], [5], [D20]) (figure 6-31a).

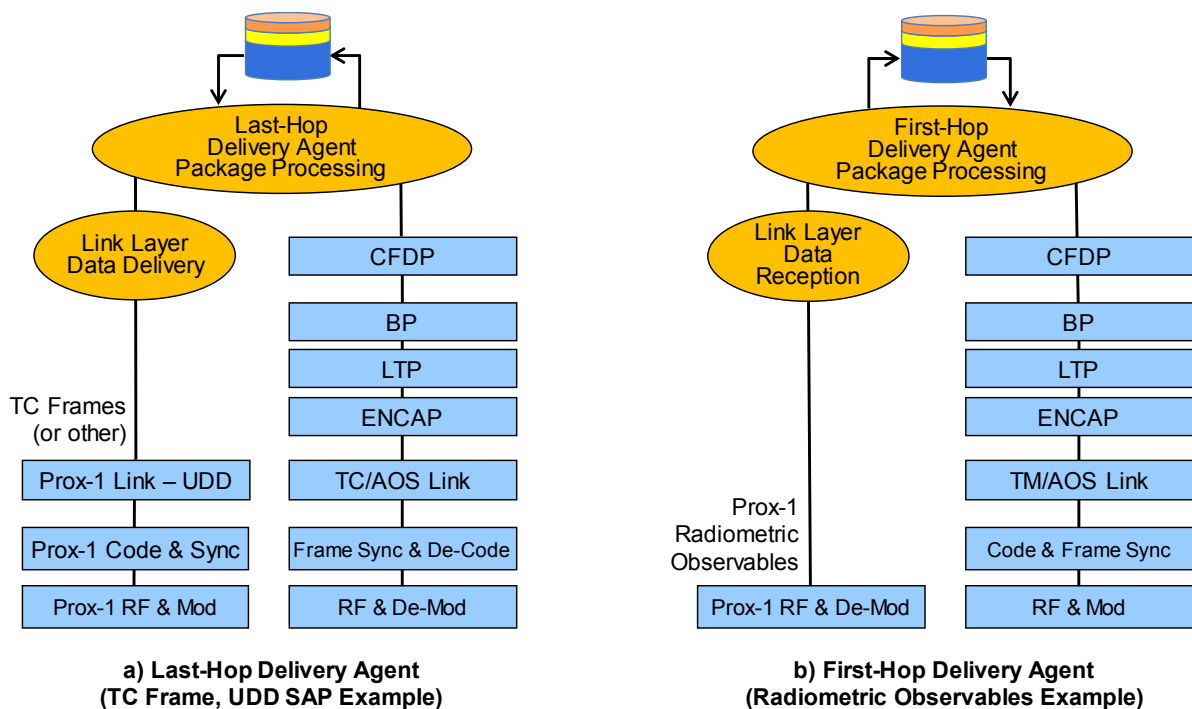

Figure 6-31: SSI Last-Hop/First-Hop Delivery Agent Building Blocks

6.2.4.2.2 [Future] SSI space routing nodes implementing the last-hop delivery functions (references [5], [D20]) should receive delivery packages via CFDP (reference [39]) (figure 6-31a).

CCSDS RECOMMENDED PRACTICE FOR SPACE COMMUNICATIONS CROSS SUPPORT—
ARCHITECTURE REQUIREMENTS DOCUMENT

6.2.4.2.3 [Future] SSI space routing nodes implementing the last-hop delivery functions (references [5], [D20]) should process the delivery package and interpret the instructions (references [5], [D20]) (figure 6-31a).

6.2.4.2.4 [Future] SSI space routing nodes implementing the last-hop delivery functions (references [5], [D20]) should deliver the link layer data to the end node as directed (references [5], [D20]) (figure 6-31a).

NOTE – Last-hop delivery will typically be link layer frames or Bose, Chaudhuri, Hocquenghem (BCH) code blocks. The delivery may be via Prox-1, as shown in figure 6-31a, or via a TC or AOS link.

6.2.4.2.5 [Future] SSI space routing nodes supporting end user SSI nodes and non-SSI nodes should implement the first-hop delivery functions (references [5], [D20]) (figure 6-31b).

6.2.4.2.6 [Future] SSI space routing nodes implementing the first-hop delivery functions (references [5], [D20]) should receive delivery packages via CFDP (reference [39]) (figure 6-31a).

6.2.4.2.7 [Future] SSI space routing nodes implementing the first-hop delivery functions (references [5], [D20]) should process the delivery package and interpret the instructions (references [5], [D20]) (figure 6-31b).

6.2.4.2.8 [Future] SSI space routing nodes implementing the first-hop delivery functions (references [5], [D20]) should accept link layer data from the end node as directed (references [5], [D20]) (figure 6-31b).

6.2.4.2.9 [Future] SSI space routing nodes implementing the first-hop delivery functions (references [5], [D20]) should accept open loop recorder data from the end node as directed (references [5], [D20]) (figure 6-31b).

6.2.4.2.10 [Future] SSI space routing nodes implementing the first-hop delivery functions (references [5], [D20]) should accept radiometric and tracking data from the end node as directed (references [5], [D20]) (figure 6-31b).

6.2.4.2.11 [Future] SSI space routing nodes implementing the first-hop delivery functions (references [5], [D20]) should create a delivery package from the received data (reference [D20]) (figure 6-31b).

6.2.4.2.12 [Future] SSI space routing nodes implementing the first-hop delivery functions (references [5], [D20]) should send the delivery packages via CFDP (reference [39]) (figure 6-31b).

NOTES

- 1 First-hop delivery may involve return of coded or uncoded link layer frames, or sampled tracking and radiometric data, or the results of open loop recording of a free space signal. The reception may be via Prox-1, via a TM or AOS link, or using features of the routing node radio.
- 2 SSI Earth routing nodes and SSI Earth User Nodes will have to construct and send last-hop delivery packages. In the SSI era, ABA Earth User Nodes may also need to create last-hop delivery packages to communicate via SSI with remote ABA Space User Nodes.

6.2.4.2.13 [Future] SSI Earth routing nodes or SSI/ABA Earth User Nodes supporting end-user SSI nodes and non-SSI (ABA) nodes shall implement the last-hop delivery package functions (references [D5], [5], [D20]) (figure 6-32).

6.2.4.2.14 [Future] SSI Earth routing nodes or SSI/ABA Earth User Nodes implementing the last-hop delivery functions (references [5], [D20]) should send delivery packages via CFDP (reference [39]) (figure 6-19b).

6.2.4.2.15 [Future] SSI Earth routing nodes or SSI/ABA Earth User Nodes implementing the last-hop delivery functions (references [5], [D20]) shall create the delivery package and the required delivery instructions (references [5], [D20]) (figure 6-32).

CCSDS RECOMMENDED PRACTICE FOR SPACE COMMUNICATIONS CROSS SUPPORT—
 ARCHITECTURE REQUIREMENTS DOCUMENT

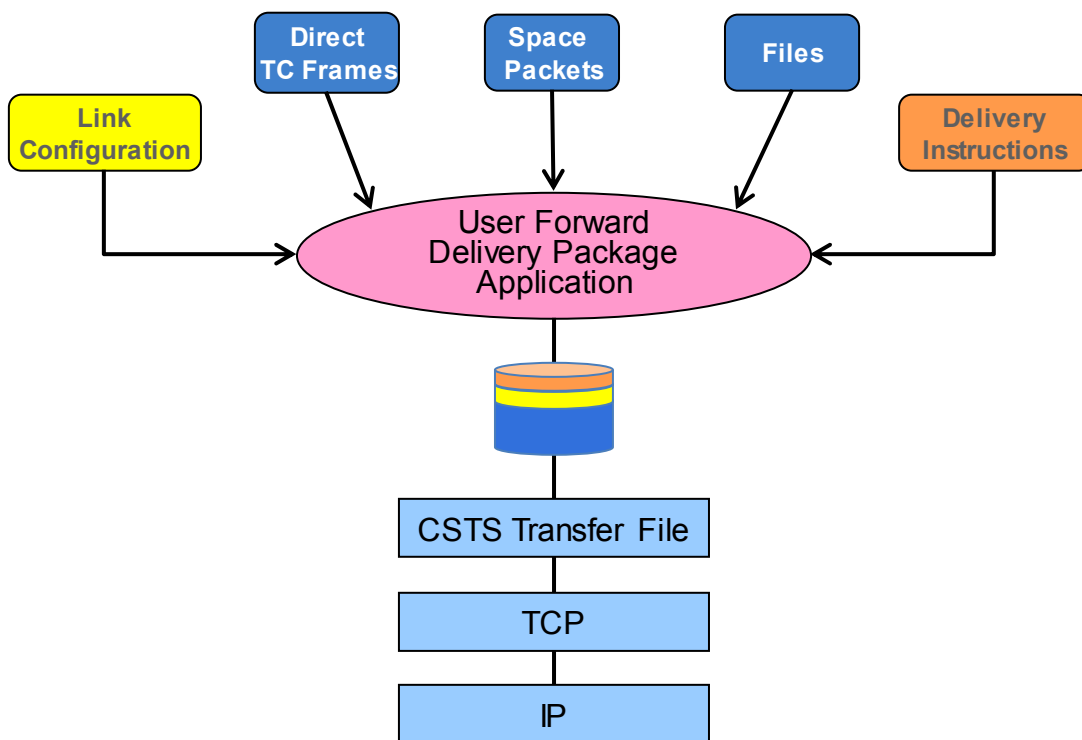

**ABA Last-Hop Delivery Package Assembly
 and CSTS Transfer-File Delivery**

Figure 6-32: SSI User Last-Hop/First-Hop Transfer File Building Block

6.2.4.2.16 [Future] SSI Earth routing nodes or SSI/ABA Earth User Nodes implementing the last-hop delivery functions (references [5], [D20]) shall include the link layer data and link configuration information (figure 6-32).

NOTES

- 1 Last-hop delivery will typically be link layer frames or BCH code blocks. The delivery may be via Prox-1, as shown in figure 6-31a, or via a TC or AOS link.
- 2 SSI Earth routing nodes and SSI Earth User Nodes will have to receive and process first-hop delivery packages. In the SSI era, ABA Earth User Nodes may also need to receive and process first-hop delivery packages to communicate via SSI with remote ABA Space User Nodes.

6.2.4.2.17 [Future] SSI Earth routing nodes and SSI/ABA Earth User Nodes supporting end user SSI nodes and non-SSI nodes should implement the first-hop delivery package functions (references [5], [D20]) (similar to figure 6-32).

6.2.4.2.18 [Future] SSI Earth routing nodes and SSI/ABA Earth User Nodes implementing the first-hop delivery functions (references [5], [D20]) should receive delivery packages via CFDP (reference [39]) (symmetric to figure 6-19b).

6.2.4.2.19 [Future] SSI Earth routing nodes or SSI/ABA Earth User Nodes implementing the first-hop delivery functions (references [5], [D20]) shall process the returned delivery package using the supplied delivery instructions (references [5], [D20]) (symmetric to figure 6-32).

6.2.4.2.20 [Future] SSI Earth routing nodes or SSI/ABA Earth User Nodes implementing the first-hop delivery functions (references [5], [D20]) shall process the returned data and link configuration information (symmetric to figure 6-32).

6.2.4.2.21 [Future] SSI Earth routing nodes or SSI/ABA Earth User Nodes implementing the first-hop delivery functions (references [5], [D20]) shall process the link layer, radiometric/tracking, or open loop recorded data as indicated by the delivery instructions (symmetric to figure 6-32).

CCSDS RECOMMENDED PRACTICE FOR SPACE COMMUNICATIONS CROSS SUPPORT—
ARCHITECTURE REQUIREMENTS DOCUMENT

7 END-TO-END DEPLOYMENT VIEW

7.1 OVERVIEW

This section addresses end-to-end deployments of system elements and provides only a couple of examples of node, service, and protocol deployments for the provision of either ABA or SSI SCCS services. Building upon the element-by-element protocol stack views shown in the communications view (section 6), this section defines how these elements are to be assembled to provide end-to-end data delivery.

These deployment requirements cover basic ABA deployments, control of space link ‘B’ by mission ‘A’ ground system, and some transitional single-hop ABA configurations that include SSI protocols. This section also defines requirements for nominal SSI ABCBA deployments, as well as SSI ABCBA deployments supporting non-SSI relays, transition of non-SSI node to SSI node, last-hop service from SSI routing node, and last-hop service from non-SSI relay node.

Each of these subsections defines requirements for nominal end-to-end physical node deployments, end-to-end communication services, ground cross support services, space-ground and space-space services (if any), and any required user or provider node-specific services. All of these end-to-end stack deployment diagrams show labels for ‘ABA stacks’ or ‘SSI stacks’, not ‘ABA Agencies’. It is possible to have an ‘Agency B’ SSI ESLT supporting an ‘Agency A’ ABA Earth User Node and Space User Node.

Actual system deployments may include more than one service—such as ABA, SSI, and CFDP file service—and also a last-hop service element. Some deployments may include the standard service requirements defined here and also agency- or mission-specific ones, such as customized use of Space Packets (SPs) for mission operations-specific functions.

There are so many possible end-to-end configurations that there is no attempt in this section to be all-inclusive. The reader is directed to the SCCS-ADD (reference [D5]) for more examples and descriptions of other possible configurations.

NOTE – There is no direct treatment of mission operations services; they are assumed to use the standard end-to-end frame-, network-, file-, or message-delivery functions. Nor does this section define any other mission-unique applications or services that may use the underlying frame, file, or internetworking services to deliver their data.

7.2 ABA END-TO-END PROTOCOL VIEWS—REQUIREMENTS

7.2.1 BASIC ABA END-TO-END PROTOCOL VIEWS

7.2.1.1 ABA end-to-end deployments should adopt a single forward link layer communication protocol stack using TC frames (reference [31]) and a service provider offering SLE F-CLTU services (reference [21]) (figure 7-1).

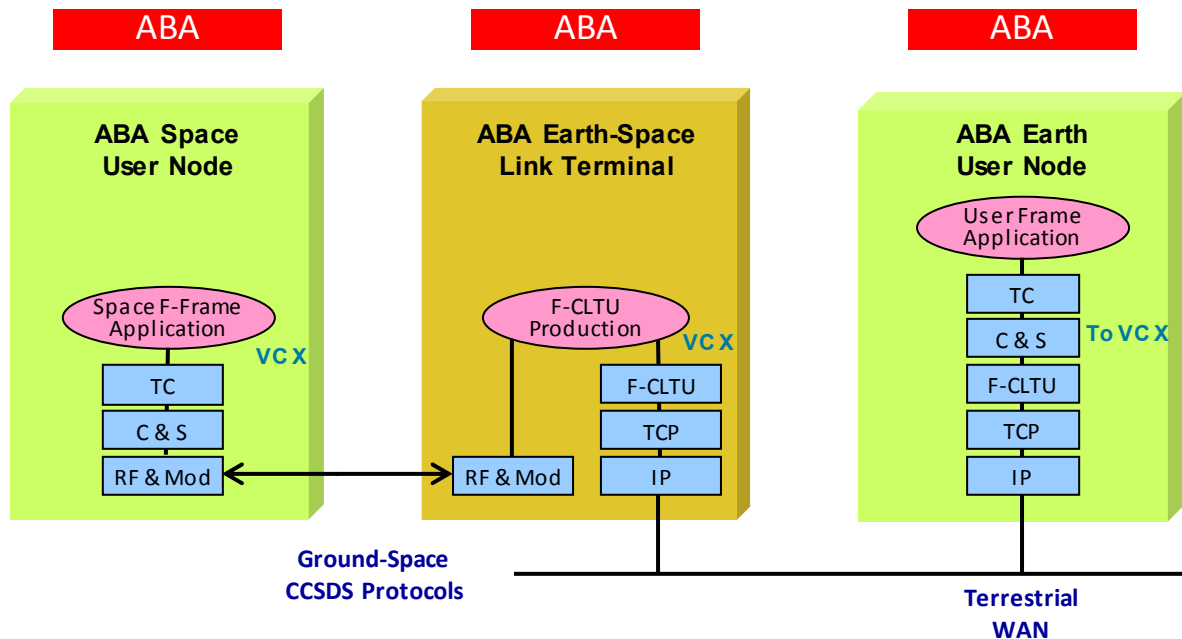

C & S = Coding & Synchronization

Figure 7-1: ABA End-to-End Forward: ABA Agency Supporting ABA Agency

7.2.1.2 [Future] ABA end-to-end deployments may adopt a single forward link layer communication protocol stack using AOS frames (reference [9]) or TC frames (reference [31]) and a service provider offering CSTS F-Frame services (reference [D14]) (similar to figure 7-1).

7.2.1.3 ABA end-to-end deployments shall implement a single return link layer communication protocol stack using TM (reference [10]) or AOS frames (reference [9]) and a service provider offering SLE RAF or RCF services (reference [22] or [23]) (symmetric with figure 7-1).

7.2.1.4 ABA end-to-end deployments may implement an Application Layer communication stack in the Earth and Space User Nodes using file, packet, or other services (figure 7-1).

7.2.2 ABA END-TO-END PROTOCOL VIEWS WITH BP DELIVERY

[Future] ABA end-to-end deployments may implement a Network Layer communication stack in the user Earth and Space User Nodes using DTN or other protocols and a service provider offering CSTS F-Frame and SLE RCF services (references [23], [D14]) (similar to figure 7-2, without routing nodes).

CCSDS RECOMMENDED PRACTICE FOR SPACE COMMUNICATIONS CROSS SUPPORT—
ARCHITECTURE REQUIREMENTS DOCUMENT

7.3 SSI END-TO-END PROTOCOL VIEWS: REQUIREMENTS

7.3.1 CORE SSI END-TO-END ABCBA PROTOCOL VIEWS

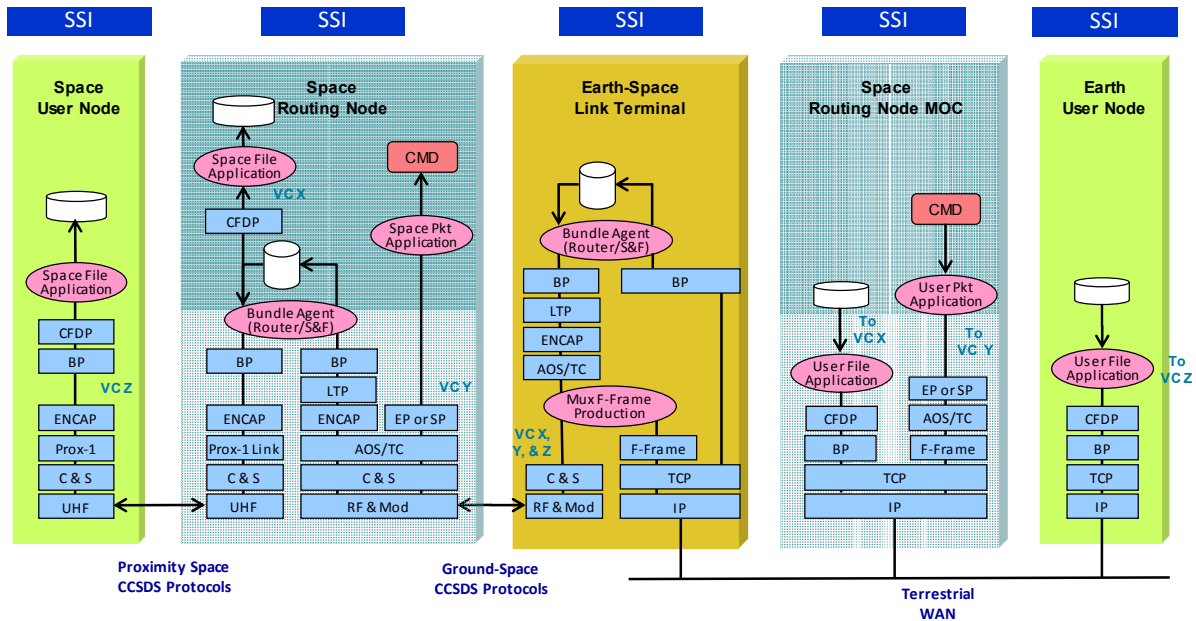

Figure 7-2: SSI End-to-End Forward: SSI Agency Supporting SSI Agency

7.3.1.1 [Future] SSI end-to-end deployments shall adopt a single Network Layer communication protocol stack using either the DTN suite or IPS (or both), an ESLT service provider offering CSTS F-Frame services (reference [D14]) and SLE RCF services (reference [23]) (figure 7-2).

7.3.1.2 [Future] SSI end-to-end deployments with intermittent link connectivity, BDP $>10^7$, or long RTLTL (>2 seconds) should use the basic DTN internetworking service interfaces (reference [DTN]).

7.3.1.3 [Future] SSI end-to-end deployments with continuous link connectivity, BDP $<10^7$ and short RTLTLs (<2 seconds) shall use one of the basic IP (reference [IPS]) or DTN internetworking service interfaces (reference [DTN]).

7.3.1.4 [Future] SSI end-to-end deployments may implement an Application Layer communication stack in the user Earth and Space User Nodes using file, packet, or other services (figure 7-2).

7.3.1.5 [Future] SSI end-to-end deployments may implement either a Network Layer communication stack or a link layer stack in the space routing node MOC, or both (figure 7-2).

7.3.1.6 [Future] SSI end-to-end deployments may implement both a Network Layer communication stack and a link layer stack in the space routing node (figure 7-2).

7.3.1.7 [Future] SSI end-to-end deployments may include non-SSI space routing nodes and MOCs if the space routing node includes a component that provides last-hop and first-hop services (reference [D20]) (not shown in figure 7-2).

7.3.2 SSI PLANETARY SPACE LINK TERMINAL AND WAN PROTOCOL VIEW

[Future] SSI end-to-end deployments may implement a Network Layer communication stack in a PSLT that supports either proximate or LAN links (TBD) (similar to figure 7-2 with PSLT instead of space routing node).

7.3.3 SSI EXTENDED DTN FUNCTIONS: EMERGENCY COMMUNICATIONS AND LAST-HOP DELIVERY

[Future] SSI end-to-end deployments may implement a last-hop or first-hop application (reference [D20]) to link or Physical-Layer communication stack in the space routing node to service ABA end nodes and SSI nodes in need of emergency or contingency services (not shown in figure 7-2).

7.3.4 SSI TRANSITION: ABA AGENCY SUPPORTING SSI AGENCY

7.3.4.1 [Future] SSI Stage 1 end-to-end deployments should adopt a single forward link layer communication protocol stack using AOS frames (reference [9]) or TC frames (reference [31]) and an ABA ESLT service provider offering CSTS F-Frame (reference [D14]) services (like figure 7-1 with SSI 'A' nodes).

7.3.4.2 [Future] SSI Stage 1 end-to-end deployments should implement a single return link layer communication protocol stack using TM (reference [10]) or AOS frames (reference [9]) and an ABA ESLT service provider offering SLE RAF or RCF services (reference [22] or [23]) (symmetric with figure 7-1 with SSI 'A' nodes).

CCSDS RECOMMENDED PRACTICE FOR SPACE COMMUNICATIONS CROSS SUPPORT—
ARCHITECTURE REQUIREMENTS DOCUMENT**7.4 DISCUSSION—SECURITY REQUIREMENTS FOR END-TO-END DEPLOYMENTS**

Security for the end-to-end protocol deployments utilizes all of the security elements addressed in earlier sections. In this section, use of end-to-end user encryption will be shown as a means to secure transfers to the final space routing nodes or Space User Nodes. For ABA deployments this was described in 6.2.2.7. For SSI deployments, as described in 6.2.3.7, Network Layer security may also be applied, or users may choose to apply encryption at the Application Layer.

Figure 7-3 shows two approaches for securing the data in an ABA end-to-end configuration. These optional stack elements are shown in green. SDLS is used to provide end-to-end link layer security for an SPP packet flow. The ABA user node may apply one (or both) of the encryption or authentication algorithms to packet data, load this into an AOS or TC frame inside the SDLS security block, and then use the normal service-delivery mechanisms to transmit the data to the user space node, as provided by the SDLS authentication/encryption layer.

NOTE – The ESLT service provider stack in figure 7-3 does not show the presence of the SDLS authentication/encryption layer, since that security block is opaque to the CSTS F-Frame service.

Alternatively, the user MOC may apply encryption or authentication to a data file (file secure), and that file may then be merged into the secure F-Frame stream. In both of these cases the ABA Space User Node must be prepared to undo the security that has been applied, and some private means for establishing and managing keys must also be implemented. Both of these methods offer end-to-end link layer security.

Figure 7-3 also shows use of IPsec as an additional layer of encryption that optionally may be applied at the Network Layer to secure the IP traffic over the Internet. In most configurations, only one or another of these mechanisms might be employed and it would be unusual to elect to use all of them simultaneously, as is shown in this figure.

Figure 7-4 shows three separate, optional alternatives for securing an SSI end-to-end data transfer, using DTN and either AMS or CFDP in this example. The SSI Earth User Node may apply one of the encryption or authentication algorithms to its command data and load that into a file. This secured file provides end-to-end data security. The secured file—or AMS messages as in this example—may be secured by the SBSP and transferred in a BP bundle. On the terrestrial hop, BP/SBSP may then use TCP/IP and IPsec to securely transmit the data to the ESLT. The ESLT, which merges data from multiple sources, will re-apply SBSP security for the ESLT to Space User Node hop. Once the file is at the Space User Node, the file security may be removed.

These same mechanisms work across multiple SSI hops. The final layers of security are only applied and removed in the end nodes.

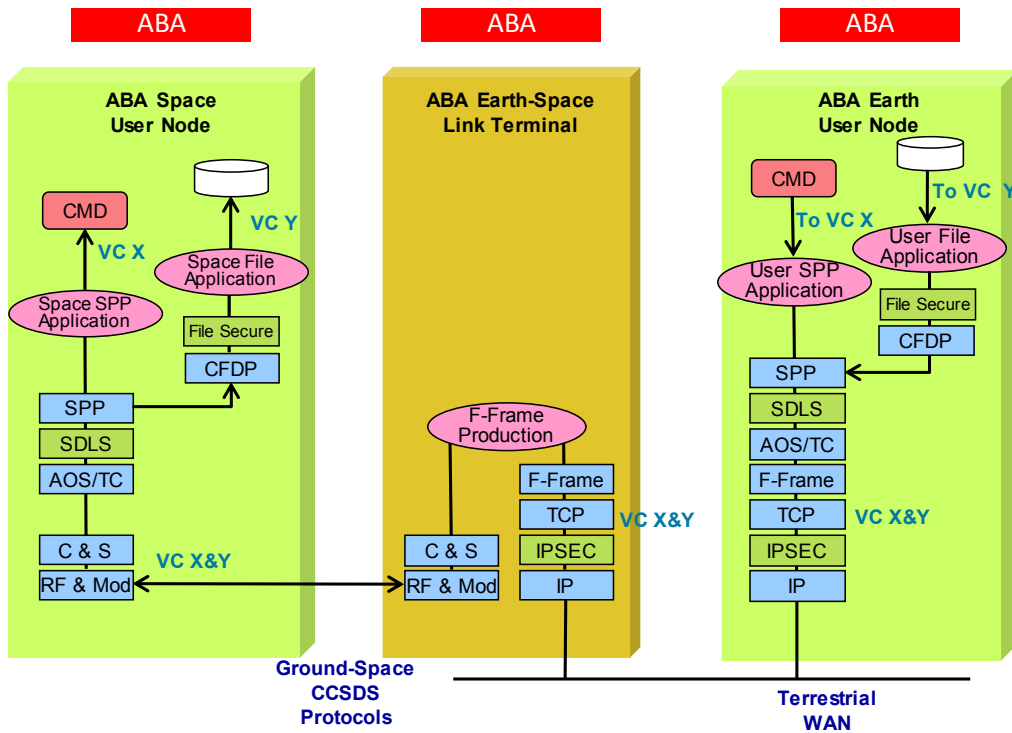

Figure 7-3: ABA Secure End-to-End Forward: ABA Agency Supporting ABA Agency

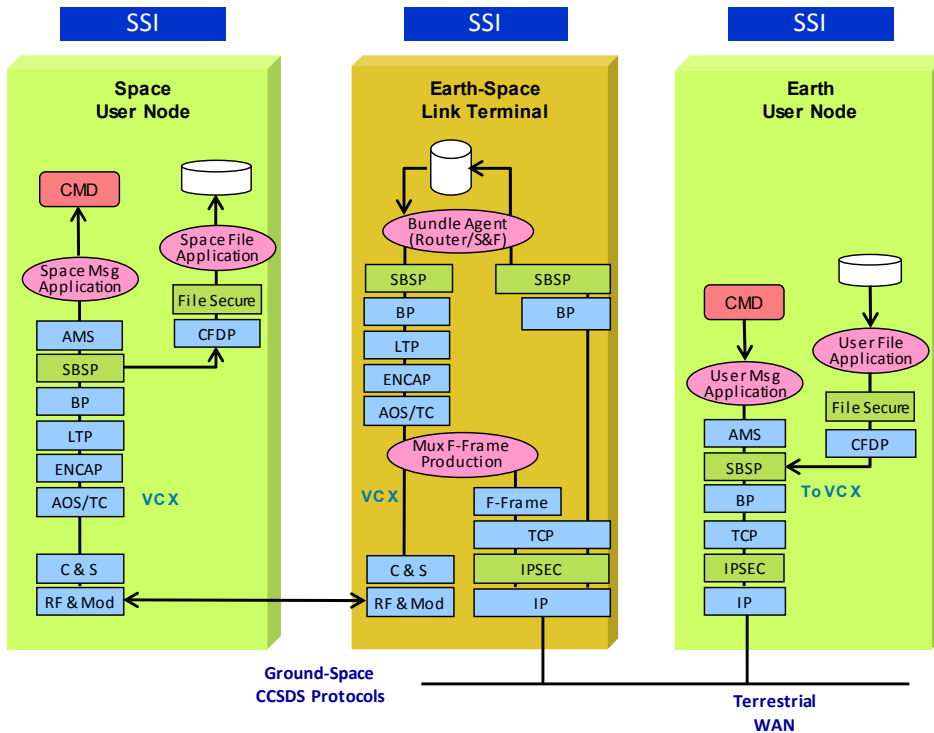

Figure 7-4: SSI Secure End-to-End Forward: SSI Agency Supporting SSI Agency

CCSDS RECOMMENDED PRACTICE FOR SPACE COMMUNICATIONS CROSS SUPPORT—
ARCHITECTURE REQUIREMENTS DOCUMENT

It will seldom be the case that all of these security measures will be applied in any one deployment, but it is possible. Where terrestrial security is essential, IPSec may be applied, as this masks Internet traffic from any snooping. SBSP may be employed end-to-end for command or sensitive data or where service providers that do not belong to the same agency as the user are involved. If a given Space User Node hosts instruments belonging to different agencies, the agency might elect to separately secure their command uplinks, or data returns, by use of file-level security.

ANNEX A

SECURITY AND SANA CONSIDERATIONS

(INFORMATIVE)

A1 SECURITY CONSIDERATIONS WITH RESPECT TO THE CCSDS DOCUMENT

Security concerns are handled within each of sections 4–7 as needed.

A2 SANA CONSIDERATIONS WITH RESPECT TO THE CCSDS DOCUMENT

No new SANA registries are created in this document. The use of existing SANA registries is referenced, as needed, in-line throughout the document.

ANNEX B

GLOSSARY

(INFORMATIVE)

Application Layer services: OSI Layer 7 services provided to user applications, such as file or message transfer.

BCH code: A parameterized error-correcting code used for uplink commanding.

cross support: An agreement between two or more organizations to exploit the technical capability of interoperability for mutual advantage, such as one organization offering support services to another in order to enhance or enable some aspect of a space mission.

cross support service: A function provided by one space agency to support operations of a space mission of another space agency.

cross support service element, CSSE: A physical element involved in providing one or more cross support services (including functions for managing services).

cross support service system, CSSS: A set of CSSEs that is managed by a single authority with a single set of management policies.

data store: Staging for data in transit on the network.

Earth-space terminal access: A port that provides access to a space link terminal on Earth.

Earth user access: A port that provides access to a space link user on the ‘ground’ (i.e., Earth or another planetary surface).

Earth User Node: A physical element, located on the ground, that uses a cross support service provided by a CSSS.

emergency communication services: Specialized services for delivering emergency, ‘last hop’, or primitive ‘brain stem’ commanding to a spacecraft.

encapsulation: A function that wraps a PDU in another PDU in order to transfer it to its destination.

forward data: Data sent from a ground element to a space element.

forwarding: The act of transferring data from its source towards its destination, which may be in space or on the ground.

gateway: A function that provides protocol translation between two different, but compatible, protocols at the same OSI Layer, e.g., IP to BP.

governance: Decision making that defines expectations, grants power, or verifies performance. It consists either of a separate process, or of a specific part of management or leadership processes. Governance relates to consistent management, cohesive policies, processes, and decision rights for a given area of responsibility.

in-space: Extraterrestrial. In this usage, in-space communications includes Earth-to-space, space-to-space, space-to-planetary surface, planetary surface-to-surface, etc.

internetworking: Practice of connecting two or more distinct computer networks or network segments together to form an internetwork (often shortened to *internet*), using devices which operate at OSI Layer 3 (Network Layer) of the OSI Basic Reference Model [4] (such as routers or Layer 3 switches) to connect them together to allow traffic to flow back and forth between them. The OSI Layer 3 routing devices guide traffic on the correct path (among several different ones usually available) across the complete internetwork to their destination.

interoperability: A property of protocols or systems whereby elements adopt a commonly defined and implemented set of protocols, data, and behaviors.

Network Layer processing: OSI Layer 3 processing that includes any needed routing, forwarding, and management functions.

network management: Real-time control of space communication service functions.

node: A space data system physical entity operating in a physical environment. A node is a configuration of engineering objects forming a single unit for the purpose of location in space, and embodying a set of processing, storage, and communication functions. A node has some well-understood, possibly rapidly moving location, and it may be composed of two or more (sub-)nodes.

planet-space terminal access: A port that provides access to a space link terminal on a planetary body.

protocol data unit, PDU: A unit of data which is specified in a protocol of a given layer and which consists of protocol-control information, addressing information, and possibly user data for that layer.

return data: Data sent from a space element to a ground element.

router: A device that forwards Network Layer PDUs between computer networks, creating an Internetwork. A router is connected to two or more data links from different subnetworks and uses address information in the PDU and information in its routing table or routing policy to direct the PDU to the next subnetwork.

routing: The process of selecting paths from origins to destinations in a network.

CCSDS RECOMMENDED PRACTICE FOR SPACE COMMUNICATIONS CROSS SUPPORT—
ARCHITECTURE REQUIREMENTS DOCUMENT

service management: 1) The set of functions exposed by PM to utilization management for the purposes of acquiring and managing the services provided by the provider CSSS to the user CSSS. These functions include planning, scheduling, and managing the configuration of space communication service functions. 2) The specification for exchanging service management information.

service provider: The role played by a physical, functional, or organizational entity that provides a cross support service for a service user. (A single entity may simultaneously play the roles of service provider and service user.)

service user: The role played by a physical, functional, or organizational entity that uses a cross support service provided by a service provider. (A single entity may play the roles of service provider and service user at the same time.)

Solar System Internetwork, SSI: A loose confederation of independent space communications networks that all share a single Network-Layer protocol (DTN or IP) that allows them to interoperate and exchange Network-Layer PDUs, each often owned and administered by a different space agency.

space asset access: A port that provides access to spaceborne assets offering functions such as routing or relaying.

space internetworking services: Specialized services performing internetworking for space applications using either the DTN protocol suite, or, in certain suitable situations, the IP suite.

space link: A communications link between a spacecraft and its associated ground system or between two spacecraft. A space link consists of one or more physical channels in one or both directions.

space link access: A port that provides access to a space link.

space link application services: Specialized services offering direct access to the space link layer, such as VC service, insert zone.

space link interface: The interface of a CSSE that uses space link protocols.

space link layer processing: Processing at OSI Layers 1 and 2 for space communications, includes any needed framing, coding, and modulation.

space routing node: A physical element located in space that provides space internetworking services.

space user access: A port that provides access for an end-user node.

Space User Node: A physical element located in space that uses a cross support service provided by a CSSS.

store and forward (S&F): The process of holding data (store) until a path is available to send it to its destination (forward).

supported agency: A space agency that uses cross support services.

supporting agency: A space agency that provides cross support services.

terrestrial-link interface: The interface of a CSSE that uses terrestrial link (and networking) protocols.

terrestrial link layer processing: OSI Layers 1 and 2 processing for ground communications, including any needed framing, coding, and modulation.

user applications: OSI Layer 8 functions that use other communications services.

virtual channel, VC: A capability to logically split a single physical channel into multiple virtual ones.

WAN access: A port that provides access to a wide area network.

xmit: Transmit data over a space link.

CCSDS RECOMMENDED PRACTICE FOR SPACE COMMUNICATIONS CROSS SUPPORT—
ARCHITECTURE REQUIREMENTS DOCUMENT

ANNEX C

ABBREVIATIONS

(INFORMATIVE)

ADD	architecture description document
ADSL	asymmetric digital subscriber line
AMS	Asynchronous Message Service
AOS	Advanced Orbiting Systems
ARD	architecture requirements document
BCH	Bose, Chaudhuri, Hocquenghem
BDP	bandwidth delay product
BP	Bundle Protocol
BPA	Bundle Protocol agent
BSP	Bundle Security Protocol
C&S	coding & synchronization
CCSDS	Consultative Committee for Space Data Systems
CFDP	CCSDS File Delivery Protocol
CGRP	Contact Graph Routing Protocol
CLA	convergence layer adapter
CLCW	communications link control word
CLTU	communication link transmission unit
COP	communications operations procedure
CSRM	Cross Support Reference Model
CSSE	cross support service element
CSSS	cross support service system

CSTS	Cross Support Transfer Services
CXFS	Cross-Support File Service
DMZ	demilitarized zone
DOR	differential one-way range
DSLAM	digital subscriber line access multiplexer
DTN	Delay-Tolerant Networking
EF-CLTU	Enhanced Forward Communication Link Transmission Unit
EM	element management
ENCAP	Encapsulation (packet service)
EP	Encapsulation packet
ESLT	Earth-space link terminal
ESCCS-SM	Extensible Space Communication Cross Support Service Management
F-CLTU	forward-communication link transmission unit
FARM	frame acceptance and reporting mechanism
F-Frame	forward frame
FOP	frame operation procedure
FTP	File Transfer Protocol
GEO	geosynchronous Earth orbit
GSCID	global spacecraft identifier
HTTP	Hypertext Transfer Protocol
IANA	Internet Assigned Numbers Authority
I/F	interface
IETF	Internet Engineering Task Force
IOAG	Interagency Operations Advisory Group
IP	Internet Protocol

CCSDS RECOMMENDED PRACTICE FOR SPACE COMMUNICATIONS CROSS SUPPORT—
ARCHITECTURE REQUIREMENTS DOCUMENT

IPS	Internet Protocol suite
IPSec	Internet Protocol Security
ISO	International Organization for Standardization
ISP	internet service provider
LAN	local area network
LFN	long fat network
LTP	Licklider Transmission Protocol
MOC	mission operations center
MRO	Mars Reconnaissance Orbiter
NSA	network service agreement
OCF	operational control field
OSCP	Overview of Space Communication Protocols
OSI	Open Systems Interconnection
PA	peering agreement
PDU	protocol data unit
PLOP	physical link operations procedure
PM	provision management
PN	pseudo-noise
PSLT	planet-space link terminal
RAF	return all frames
RASDS	Reference Architecture for Space Data Systems
RCF	return channel frames
RDEF	raw data exchange format
RF	radio frequency
RFC	Request for Comment

RLSN	really long skinny networks
RTLTL	round-trip light time
S&F	store and forward
SANA	Space Assigned Numbers Authority
SAP	service access point
SBSP	Streamlined Bundle Security Protocol
SCID	spacecraft identifier
SCCS	Space Communications Cross Support
SCPS-TP	Space Communications Protocol Specification—Transport Protocol
SD	service delivery
SFTP	Secured File Transfer Protocol
SISG	Space Internetworking Strategy Group
SLA	service-level agreement
SLE	Space Link Extension
SM	service management
SP	space packet
SPP	Space Packet Protocol
SR	service request
SSI	Solar System Internetwork
SSI-SP	Solar System Internet service provider
TBD	to be determined
TC	telecommand (pertains to TC Space Data Link Protocol)
TCP/IP	Transmission Control Protocol/Internet Protocol
TM	telemetry (pertains to TM Space Data Link Protocol)
TT&C	telemetry, tracking, and command

CCSDS RECOMMENDED PRACTICE FOR SPACE COMMUNICATIONS CROSS SUPPORT—
ARCHITECTURE REQUIREMENTS DOCUMENT

UDD	user defined data
UDP	User Datagram Protocol
UM	utilization management
UTC	Universal Time Coordinated
VC	virtual channel
VOIP	voice over Internet Protocol
VPN	virtual private network
WAN	wide area network
XML	Extensible Markup Language

ANNEX D

INFORMATIVE REFERENCES

(INFORMATIVE)

- [D1] J. Hawkinson and T. Bates. *Guidelines for Creation, Selection, and Registration of an Autonomous System (AS)*. RFC 1930. Reston, Virginia. ISOC, March 1996.
- [D2] *Mars Mission Protocol Profiles—Purpose and Rationale*. Issue 1. Report Concerning Space Data System Standards (Green Book), CCSDS 740.0-G-1. Washington, D.C.: CCSDS, July 2008.
- [D3] *Bandwidth-Efficient Modulations: Summary of Definition, Implementation, and Performance*. Issue 2. Report Concerning Space Data System Standards (Green Book), CCSDS 413.0-G-2. Washington, D.C.: CCSDS, October 2009.
- [D4] *Recommendations on a Strategy for Space Internetworking*. Errata/Clarification added. Report of the Interagency Operations Advisory Group Space Internetworking Strategy Group, IOAG.T.RC.002.V1. Washington, DC: IOAG, August 1, 2010.
- [D5] *Space Communications Cross Support—Architecture Description Document*. Issue 1. Report Concerning Space Data System Standards (Green Book), CCSDS 901.0-G-1. Washington, D.C.: CCSDS, November 2013.
- [D6] *Cross Support Transfer Service—Specification Framework*. Issue 2. Draft Recommendation for Space Data System Standards (Red Book), CCSDS 921.1-R-2. Washington, D.C.: CCSDS, May 2014.
- [D7] *Solar System Internetwork (SSI) Architecture*. Issue 1. Report Concerning Space Data System Standards (Green Book), CCSDS 730.1-G-1. Washington, D.C.: CCSDS, July 2014.
- [D8] *Overview of Space Communications Protocols*. Issue 3. Report Concerning Space Data System Standards (Green Book), CCSDS 130.0-G-3. Washington, D.C.: CCSDS, July 2014.
- [D9] *Space Communication Cross Support—Service Management—Service Specification*. Issue 1. Recommendation for Space Data System Standards (Blue Book), CCSDS 910.11-B-1. Washington, D.C.: CCSDS, August 2009.
- [D10] *Extensible Space Communication Cross Support—Service Management—Concept*. Issue 1. Report Concerning Space Data System Standards (Green Book), CCSDS 902.0-G-1. Washington, D.C.: CCSDS, September 2014.
- [D11] S. Burleigh. *Contact Graph Routing Protocol (CGRP)*. Proposed IETF document.

CCSDS RECOMMENDED PRACTICE FOR SPACE COMMUNICATIONS CROSS SUPPORT—
ARCHITECTURE REQUIREMENTS DOCUMENT

- [D12] E. Birrane and V. Ramachandran. *Delay Tolerant Network Management Protocol*. Proposed IRTF document.
- [D13] *Space Link Extension—Enhanced Forward CLTU Service Specification*. Issue 1. Research and Development for Space Data System Standards (Orange Book), CCSDS 912.11-O-1. Washington, D.C.: CCSDS, July 2012.
- [D14] *Cross Support Transfer Service—Forward Frame*. Proposed CCSDS document.
- [D15] *Cross Support Transfer Service—CFDP File Service*. Proposed CCSDS Recommendation.
- [D16] *Cross Support Transfer Service—Tracking Data*. Proposed CCSDS Recommendation.
- [D17] *Cross Support Transfer Service—Transfer File*. Proposed CCSDS Recommendation.
- [D18] *Cross Support Transfer Services—Monitored Data Service*. Issue 1. Draft Recommendation for Space Data System Standards (Red Book), CCSDS 922.1-R-1. Washington, D.C.: CCSDS, forthcoming.
- [D19] *Cross Support Transfer Service—Service Control*. Proposed CCSDS Recommendation.
- [D20] *Last-Hop/First-Hop Service*. Proposed CCSDS Recommendation.
- [D21] *Functional Resources for Cross Support Services*. Proposed CCSDS Recommendation.
- [D22] *Space Data Link Security Protocol*. Issue 3. Draft Recommendation for Space Data System Standards (Red Book), CCSDS 355.0-R-3. Washington, D.C.: CCSDS, October 2013.
- [D23] *Symmetric Key Management Recommendations*. Proposed CCSDS Recommendation.
- [D24] *CCSDS Bundle Protocol Specification*. Issue 3. Draft Recommendation for Space Data System Standards (Red Book), CCSDS 734.2-R-3. Washington, D.C.: CCSDS, July 2014.
- [D25] *CCSDS Guide for Secure System Interconnection*. Issue 1. Report Concerning Space Data System Standards (Green Book), CCSDS 350.4-G-1. Washington, D.C.: CCSDS, November 2007.
- [D26] *Streamlined Bundle Security Protocol for CCSDS*. Proposed CCSDS Recommendation.

NOTE – Normative references are found in 1.7.

British Standards Institution (BSI)

BSI is the national body responsible for preparing British Standards and other standards-related publications, information and services.

BSI is incorporated by Royal Charter. British Standards and other standardization products are published by BSI Standards Limited.

About us

We bring together business, industry, government, consumers, innovators and others to shape their combined experience and expertise into standards-based solutions.

The knowledge embodied in our standards has been carefully assembled in a dependable format and refined through our open consultation process. Organizations of all sizes and across all sectors choose standards to help them achieve their goals.

Information on standards

We can provide you with the knowledge that your organization needs to succeed. Find out more about British Standards by visiting our website at bsigroup.com/standards or contacting our Customer Services team or Knowledge Centre.

Buying standards

You can buy and download PDF versions of BSI publications, including British and adopted European and international standards, through our website at bsigroup.com/shop, where hard copies can also be purchased.

If you need international and foreign standards from other Standards Development Organizations, hard copies can be ordered from our Customer Services team.

Copyright in BSI publications

All the content in BSI publications, including British Standards, is the property of and copyrighted by BSI or some person or entity that owns copyright in the information used (such as the international standardization bodies) and has formally licensed such information to BSI for commercial publication and use.

Save for the provisions below, you may not transfer, share or disseminate any portion of the standard to any other person. You may not adapt, distribute, commercially exploit, or publicly display the standard or any portion thereof in any manner whatsoever without BSI's prior written consent.

Storing and using standards

Standards purchased in soft copy format:

- A British Standard purchased in soft copy format is licensed to a sole named user for personal or internal company use only.
- The standard may be stored on more than 1 device provided that it is accessible by the sole named user only and that only 1 copy is accessed at any one time.
- A single paper copy may be printed for personal or internal company use only.

Standards purchased in hard copy format:

- A British Standard purchased in hard copy format is for personal or internal company use only.
- It may not be further reproduced – in any format – to create an additional copy. This includes scanning of the document.

If you need more than 1 copy of the document, or if you wish to share the document on an internal network, you can save money by choosing a subscription product (see 'Subscriptions').

Reproducing extracts

For permission to reproduce content from BSI publications contact the BSI Copyright & Licensing team.

Subscriptions

Our range of subscription services are designed to make using standards easier for you. For further information on our subscription products go to bsigroup.com/subscriptions.

With **British Standards Online (BSOL)** you'll have instant access to over 55,000 British and adopted European and international standards from your desktop. It's available 24/7 and is refreshed daily so you'll always be up to date.

You can keep in touch with standards developments and receive substantial discounts on the purchase price of standards, both in single copy and subscription format, by becoming a **BSI Subscribing Member**.

PLUS is an updating service exclusive to BSI Subscribing Members. You will automatically receive the latest hard copy of your standards when they're revised or replaced.

To find out more about becoming a BSI Subscribing Member and the benefits of membership, please visit bsigroup.com/shop.

With a **Multi-User Network Licence (MUNL)** you are able to host standards publications on your intranet. Licences can cover as few or as many users as you wish. With updates supplied as soon as they're available, you can be sure your documentation is current. For further information, email subscriptions@bsigroup.com.

Revisions

Our British Standards and other publications are updated by amendment or revision.

We continually improve the quality of our products and services to benefit your business. If you find an inaccuracy or ambiguity within a British Standard or other BSI publication please inform the Knowledge Centre.

Useful Contacts

Customer Services

Tel: +44 345 086 9001

Email (orders): orders@bsigroup.com

Email (enquiries): cservices@bsigroup.com

Subscriptions

Tel: +44 345 086 9001

Email: subscriptions@bsigroup.com

Knowledge Centre

Tel: +44 20 8996 7004

Email: knowledgecentre@bsigroup.com

Copyright & Licensing

Tel: +44 20 8996 7070

Email: copyright@bsigroup.com

BSI Group Headquarters

389 Chiswick High Road London W4 4AL UK