

**Ships and marine  
technology —  
Marine environment  
protection:  
performance testing of  
oil skimmers —**

**Part 1: Moving water conditions**

ICS 13.020.99; 47.020.99

## National foreword

This British Standard is the UK implementation of ISO 21072:2009.

The UK participation in its preparation was entrusted to Technical Committee SME/32/-/2, Ships and marine technology - Maritime environment protection.

A list of organizations represented on this committee can be obtained on request to its secretary.

This publication does not purport to include all the necessary provisions of a contract. Users are responsible for its correct application.

**Compliance with a British Standard cannot confer immunity from legal obligations.**

This British Standard was published under the authority of the Standards Policy and Strategy Committee on 31 August 2009

© BSI 2009

ISBN 978 0 580 55499 5

### Amendments/corrigenda issued since publication

Date	Comments

---

---

**Ships and marine technology — Marine  
environment protection: performance  
testing of oil skimmers —**

Part 1:  
**Moving water conditions**

*Navires et technologie marine — Protection de l'environnement marin:  
essai de performance des écumeurs de pétrole —*

*Partie 1: Conditions en eau agitée*



**PDF disclaimer**

This PDF file may contain embedded typefaces. In accordance with Adobe's licensing policy, this file may be printed or viewed but shall not be edited unless the typefaces which are embedded are licensed to and installed on the computer performing the editing. In downloading this file, parties accept therein the responsibility of not infringing Adobe's licensing policy. The ISO Central Secretariat accepts no liability in this area.

Adobe is a trademark of Adobe Systems Incorporated.

Details of the software products used to create this PDF file can be found in the General Info relative to the file; the PDF-creation parameters were optimized for printing. Every care has been taken to ensure that the file is suitable for use by ISO member bodies. In the unlikely event that a problem relating to it is found, please inform the Central Secretariat at the address given below.



**COPYRIGHT PROTECTED DOCUMENT**

© ISO 2009

All rights reserved. Unless otherwise specified, no part of this publication may be reproduced or utilized in any form or by any means, electronic or mechanical, including photocopying and microfilm, without permission in writing from either ISO at the address below or ISO's member body in the country of the requester.

ISO copyright office  
Case postale 56 • CH-1211 Geneva 20  
Tel. + 41 22 749 01 11  
Fax + 41 22 749 09 47  
E-mail [copyright@iso.org](mailto:copyright@iso.org)  
Web [www.iso.org](http://www.iso.org)

Published in Switzerland

## Contents

Page

Foreword.....	iv
Introduction .....	v
<b>1 Scope .....</b>	<b>1</b>
<b>2 Normative references .....</b>	<b>1</b>
<b>3 Terms and definitions.....</b>	<b>1</b>
<b>4 Test facility requirements .....</b>	<b>2</b>
<b>5 Clearance requirements .....</b>	<b>4</b>
<b>6 Test parameters .....</b>	<b>4</b>
6.1 General.....	4
6.2 Test oil properties.....	4
6.3 Oil slick thickness.....	5
6.4 Skimmer operating parameters.....	5
6.5 Debris interference .....	5
<b>7 Test procedure .....</b>	<b>6</b>
7.1 Preparations prior to testing .....	6
7.2 Actions during test period .....	6
7.3 Actions after testing .....	7
<b>8 Performance parameters .....</b>	<b>8</b>
<b>9 Measurements and reporting .....</b>	<b>9</b>
9.1 General.....	9
9.2 Oil properties.....	9
9.3 Environmental parameters .....	10
9.4 Skimmer operating parameters.....	10
9.5 Other test parameters.....	10
9.6 Recovery parameters .....	10
9.7 Performance parameters (calculated parameters).....	10
9.8 Equipment specification and test documentation .....	11
<b>10 Quality control.....</b>	<b>11</b>
10.1 Test duration and fluid volume .....	11
10.2 Repetition .....	11
<b>Annex A (informative) Guidelines for controlling the thickness of a contained oil slick under the influence of water current.....</b>	<b>12</b>
<b>Bibliography .....</b>	<b>15</b>

## Foreword

ISO (the International Organization for Standardization) is a worldwide federation of national standards bodies (ISO member bodies). The work of preparing International Standards is normally carried out through ISO technical committees. Each member body interested in a subject for which a technical committee has been established has the right to be represented on that committee. International organizations, governmental and non-governmental, in liaison with ISO, also take part in the work. ISO collaborates closely with the International Electrotechnical Commission (IEC) on all matters of electrotechnical standardization.

International Standards are drafted in accordance with the rules given in the ISO/IEC Directives, Part 2.

The main task of technical committees is to prepare International Standards. Draft International Standards adopted by the technical committees are circulated to the member bodies for voting. Publication as an International Standard requires approval by at least 75 % of the member bodies casting a vote.

Attention is drawn to the possibility that some of the elements of this document may be the subject of patent rights. ISO shall not be held responsible for identifying any or all such patent rights.

ISO 21072-1 was prepared by Technical Committee ISO/TC 8, *Ships and marine technology*, Subcommittee SC 2, *Marine environment protection*.

ISO 21072 consists of the following parts, under the general title *Ships and marine technology — Marine environment protection: performance testing of oil skimmers*:

- *Part 1: Moving water conditions*
- *Part 2: Static water conditions*
- *Part 3: High viscosity oil*

## **Introduction**

ISO 21072 standardizes the performance of oil skimmers used in marine pollution control.

Some oil skimmers have previously been performance-tested under non-standard conditions and procedures, with declared performance parameters being of limited value to the end user, especially under field conditions.

ISO 21072 provides for carrying out and recording the results of full-scale tests for a skimmer under a variety of test conditions.





# Ships and marine technology — Marine environment protection: performance testing of oil skimmers —

## Part 1: Moving water conditions

### 1 Scope

This part of ISO 21072 provides a methodology for establishing quantitative performance data for oil skimmers under moving water conditions, so that the end user can objectively judge, compare and evaluate the design and performance of different skimmer units. The methodology applies to testing in a basin and requires control of oil properties and oil slick characteristics.

The method is applicable to all types of skimmers, provided that the equipment dimensions are within the physical limitations of the test basin. The test procedure provides full-scale test results for the unit tested, under controlled conditions, and for one or more classes of oil.

NOTE Care will need to be taken when applying the test results to the prediction of skimmer performance under field conditions.

### 2 Normative references

The following referenced documents are indispensable for the application of this document. For dated references, only the edition cited applies. For undated references, the latest edition of the referenced document (including any amendments) applies.

ISO 16165, *Ships and marine technology — Marine environment protection — Terminology relating to oil spill response*

### 3 Terms and definitions

For the purposes of this document, the terms and definitions given in ISO 16165 and the following apply.

#### 3.1

##### **data collection period**

period of time within the steady-state period when recovered fluid is collected for establishing performance data

#### 3.2

##### **debris**

solid or semi-solid substance that could interfere with the operation of a spill control system

**3.3**  
**emulsification factor**  
**EF**

amount of water emulsified into the oil as a result of the skimming/pumping process, not including water originally in the test fluid

NOTE It is expressed as a decimal fraction between 0 and 1.

**3.4**  
**fluid recovery rate**  
**FRR**

total volume of fluid recovered per unit time

NOTE It is expressed in cubic metres per hour (m<sup>3</sup>/h).

**3.5**  
**recovery efficiency**  
**RE**

ratio of test fluid (oil or emulsion) recovered to the total volume of fluid recovered

NOTE It is expressed as a percentage.

**3.6**  
**oil recovery rate**  
**ORR**

volume of test fluid (oil or emulsion) recovered per unit time

NOTE It is expressed in cubic metres per hour (m<sup>3</sup>/h).

**3.7**  
**oily phase**

oil that is water-free or incorporates emulsified or encapsulated water that does not readily separate out

**3.8**  
**oil skimmer**  
**skimmer**

mechanical device used to remove oil from the water surface

**3.9**  
**slick length**

average distance from the boom apex to the leading edge of the slick

**3.10**  
**slick leading edge**

upstream end of the slick; location where inflowing oil encounters the accumulated slick

**3.11**  
**steady-state period**

period of time during which the test conditions and operating parameters are constant or within acceptable variability ranges

## 4 Test facility requirements

This part of ISO 21072 is applicable to any test arrangement that allows for the control and monitoring of the test conditions.

Possible arrangements may include, but are not limited to, one or another of the following:

- a vertical flume tank;
- a horizontal flume tank or tow tank;
- any other such test facility that allows for the control and monitoring of the test conditions.

Examples are shown in Figures 1, 2 and 3.

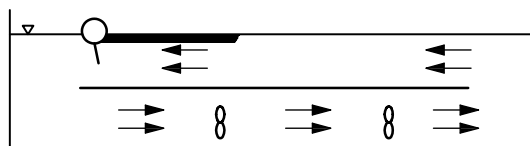

**Figure 1 — Vertical flume**

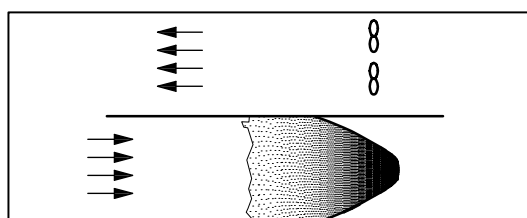

**Figure 2 — Horizontal flume**

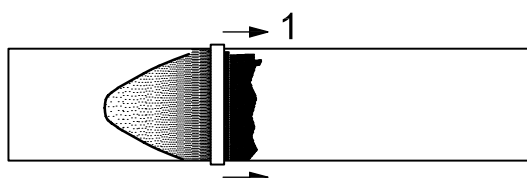

**Key**

- 1 towing bridge

**Figure 3 — Tow tank**

The test facility shall be designed and equipped to control the following parameters.

- **Oil properties.** The facility shall be able to maintain the oil properties for the duration of the test. Oil analytical equipment shall be available for measuring oil properties (see 9.2).
- **Air and water temperature.** Testing may be carried out at any water temperature, provided that requirements with respect to oil properties are met. The test temperature shall always be well above the pour point of the oil, unless the purpose is to assess the collection of non-flowing/semi-solid oil. The facility shall be able to maintain the water temperature in the test basin at a selected test temperature with maximum variation of  $\pm 2,0$  °C.

- **Oil distribution.** The facility shall incorporate the means of providing and maintaining an oil slick of the thickness required for the test.
- **Oil slick thickness.** The test facility shall incorporate means of regularly measuring oil slick thickness throughout the test period, with a proven accuracy of at least  $\pm 20\%$ .
- **Measuring tanks.** In order to provide for sufficient replicates during the test process, the test facility shall incorporate a sufficient number of calibrated tanks for accurately measuring fluid recovery rate, oil recovery rate and water uptake. The tank volumes shall correspond to the expected recovery rate of the unit to be tested so as to provide data collection periods of sufficient duration and with sufficient measuring accuracy (see 10.1).

## 5 Clearance requirements

Throughout testing, there shall be sufficient clearance between the skimmer and the tank walls and any containment device, so as not to restrict oil flow to the skimmer or otherwise impede normal operation of the unit.

Since the necessary clearance varies with oil viscosity and unit recovery rate, adequate oil flow shall be demonstrated in each specific case through oil flow observations or slick thickness measurements. The total width of the skimmer (including floats) shall not exceed 50 % of the tank width if oil flow is required to the downstream side of the skimmer.

Clearance between the unit and the tank floor shall be sufficient to not interfere with normal operations of the skimmer.

## 6 Test parameters

### 6.1 General

Testing shall establish quantitative performance data for the unit as a function of the following parameters:

- the test oil properties;
- the oil slick thickness;
- debris interference;
- the skimmer operating parameters.

### 6.2 Test oil properties

Testing shall be carried out with oils meeting the specifications given in Table 1.

To minimize problems associated with flow characteristics of waxy oils, testing shall be carried out at water temperatures at least 3 °C above the pour point of the test oil.

Oil and emulsion viscosity shall be reported at shear rates of 1 s<sup>-1</sup>, 10 s<sup>-1</sup> and 100 s<sup>-1</sup>. At least two of these shall be based on measurements, while the third may be determined by extrapolation.

In this part of ISO 21072, oil is categorized as non-emulsified (fresh) even if it contains up to 20 % water. Such oil may be used for testing as “water-free” oil, provided that the viscosity is within the ranges specified in Table 1.

All oils and emulsions may be reused, provided that the properties of the test fluids remain within the ranges defined in Table 1.

**Table 1 — Ranges for oil properties and related slick parameters**

Oil Class	Target viscosity cP	Viscosity range cP	Density kg/l	Slick thickness <sup>b, c</sup> mm	Example
1	10	5–20	0,85-0,9	10	Fresh crude, very light bunker
2	200	170–230	0,9-0,93	30	Light bunker
				50	Light bunker
3	2 000	1 800–2 200	0,92-0,95	50	Medium bunker
4	20 000	19 000–21 000	0,95-0,98	50	Heavy bunker
5	20 000	19 000–21 000 <sup>a</sup>	0,95-0,98	50	Emulsion of medium bunker
6 <sup>b</sup>	100 000	90 000–110 000 <sup>a</sup>	0,96-0,99	100	Emulsion of heavy bunker
<sup>a</sup> At a shear rate of 10 s <sup>-1</sup> . <sup>b</sup> Acceptable variation ± 10 %. <sup>c</sup> See Appendix A for guidelines on methods for controlling the oil slick thickness (6.3).					

### 6.3 Oil slick thickness

For each specific test oil, the slick thickness shall be maintained within the ranges defined in Table 1. Thickness shall be measured at a location 1,5 m from the skimmer entrance.

NOTE Annex A provides guidance for combining oil volumes and current speed in order to achieve the desired slick thickness when conducting tests in tow or flume tanks.

The oil slick thickness shall be monitored regularly throughout the test period and any deviations from the desired slick thickness shall be documented. Tests shall be rejected if the time-averaged slick thickness deviates more than 10 % from the specification given in Table 1.

### 6.4 Skimmer operating parameters

There are a number of operating parameters that can affect the skimmer performance, including adhesion surface speed, inclination angles, pump flow rates, skimmer draft and weir depth.

The main operating parameter shall be identified from the operating parameters.

Testing shall include as a minimum three variations of the main operating parameter — preferably including one above and one below the optimum setting.

### 6.5 Debris interference

Testing shall be carried out to assess the skimmer's ability to operate in the presence of various forms of debris in the oil slick. This examination will be qualitative in nature and is intended to provide the end user with a general indication of the effects of different materials that are often found in oil spill recovery situations. Of particular interest would be the debris' effects on oil intake, essential mechanical elements of the unit (e.g. scrapers, wringers, pumps) and overall processing of the recovered oil.

The groups of materials given in Table 2 shall be introduced into the oil slick individually. The impact of each group shall be observed and reported, and the group cleared from the test area before introducing the next.

**Table 2 — Materials to be introduced into oil slick**

Group of materials	Specifications
<b>Ropes</b>	Two 1,0 m × min. 25 mm diameter polypropylene rope; Two 1,0 m × min. 8 mm diameter polypropylene rope; Four 0,6 m × min. 75 mm diameter polypropylene rope
<b>Soft wood pieces</b>	One board 1,0 m × 50 mm × 100 mm; Ten blocks (10 mm × 25 mm × 40 mm)
<b>Loose materials</b>	5 l of shredded wood bark or wood shavings (min. size 5 mm; max. size 25 mm)
<b>Plastic containers</b>	Four 0,5 l soft drink bottles; Two 3 l plastic tubs
<b>Plastic bags</b>	Four plastic bags (supermarket type) approx. 300 mm × 300 mm; Two large plastic bags (domestic garbage type) approx. 500 mm × 1 000 mm

## 7 Test procedure

### 7.1 Preparations prior to testing

Carry out the following prior to testing.

- a) Prepare the required quantity of test oil, ensuring that the oil properties are according to Table 1 and with due reference to the water temperature in the test basin.
- b) Measure and record oil properties in accordance with Clause 8.
- c) Install the boom in the test tank.
- d) Locate the skimmer inside the boomed area. Ensure that the requirements with respect to clearances specified in Clause 5 are met.
- e) Start the water current and allow sufficient time for it to stabilize at the desired current velocity.
- f) Preload the tank with the test oil until the desired thickness (see Table 1) is obtained at the measuring location 1,5 m upstream of the skimmer inlet. Note and record the location of the leading edge of the slick (length of the slick) according to Annex A.

### 7.2 Actions during test period

Perform the following actions during the actual testing.

- a) Start the skimmer and adjust the operating parameters to the desired settings (speed, draft, etc.).
- b) Start the pump to offload recovered product from the skimmer sump (if applicable). It is recommended wherever possible that the fluid level in the sump be kept constant to prevent skimmer draft variations. Direct the fluid to the recovered fluid tank.
- c) Concurrently with steps a) and b), start the oil distribution mechanism and adjust it to maintain the oil slick thickness at the measuring location 1,5 m from the skimmer entrance. During periods between measurements, slick thickness may be approximately controlled by maintaining the location of the slick's leading edge (see Annex A).

- d) When steady state is achieved, divert the flow of the recovery fluid to the first measuring tank and maintain for the desired collection period or until the desired volume is collected (see Clause 8). Register the time for the start of the measuring period.
- e) Throughout the test period, regularly monitor and control the slick thickness and skimmer operating settings. Record any deviations from the desired test conditions.
- f) Once the measuring period is ended, divert the flow back to the recovered fluid tank. Register the time for the end of measuring.
- g) Provided that a steady state is maintained, divert the recovery flow to the next measuring tank.
- h) Repeat steps d) to g) for all measuring tanks.
- i) Stop oil distribution.
- j) Stop skimmer operation.

### 7.3 Actions after testing

Perform the following after testing.

- a) Allow the recovered fluid in the measuring tanks to settle for 3 min.
- b) For each measuring tank, record the total fluid quantity, quantity of water and quantity of oily phase.
- c) Take a minimum of three samples of the oily phase from each measuring tank for subsequent analysis.
- d) Measure and record the water content in the oily phase samples.

NOTE Suitable test methods are given in ISO 3733<sup>[1]</sup>, ASTM D95-05e1<sup>[2]</sup> and ASTM D6304-07<sup>[3]</sup>.

- e) Calculate performance parameters as given in Clause 8.

Figure 4 shows a schematic representation of an example test arrangement.

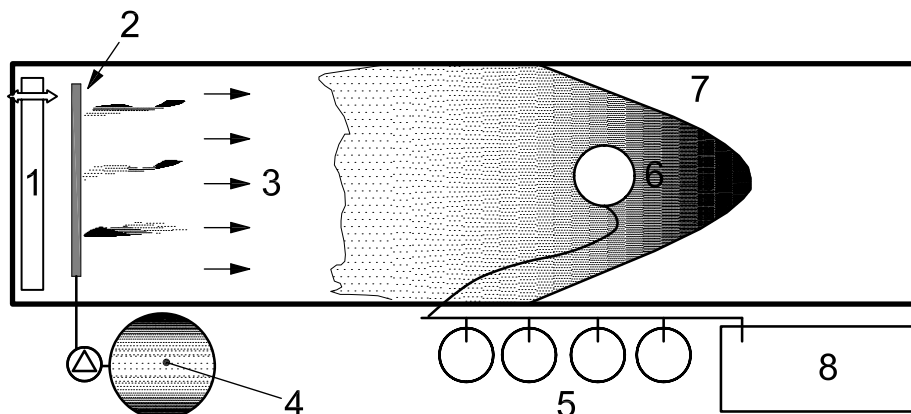

#### Key

- 1 wave generator
- 2 oil distributor
- 3 current
- 4 test oil tanks
- 5 measuring tanks
- 6 skimmer
- 7 boom
- 8 recovered fluid tank

Figure 4 — Example of test arrangement

## 8 Performance parameters

Performance of the skimmer shall be defined by the following parameters:

- fluid recovery rate (FRR);
- oil recovery rate (ORR);
- oil recovery efficiency (ORE);
- emulsification factor (EF).

### Fluid recovery rate (FRR)

This is expressed as the total amount of fluid recovered (in cubic metres) divided by the duration of the data collection period (in hours):

$$\text{FRR} = \frac{\text{recovered fluid}}{\text{time}}$$

### Emulsification factor (EF)

This is a measure of the tendency of the skimmer systems to form emulsion and is the increase in water content (emulsified) in the recovered oil compared to the original test fluid. The EF is expressed as a decimal fraction between 0 and 1 and is a function of both the test oil properties (e.g. asphaltene, wax, resins) and the skimmer's design and operation:



$$EF = \frac{\text{water content in the recovered oily phase} - \text{water content of the test fluid}}{100}$$

Therefore, EF comparisons are meaningful only for tests with identical oils.

NOTE The water content is determined in accordance with 7.3 d).

### **Oil recovery rate (ORR)**

This is expressed as the total amount of the test fluid recovered (in cubic metres) divided by the duration of the recovery period in hours:

$$ORR = \frac{\text{recovered oily phase}}{\text{time}} \times (1 - EF)$$

The ORR shall be adjusted for additional water mixed into the oily phase in the recovery process (emulsification factor).

ORR applies to emulsions as well as fresh oils, since the additional water emulsified into the oil is subtracted.

### **Oil recovery efficiency (ORE)**

This is expressed as the oil recovery rate divided by the fluid recovery rate as a percentage:

$$ORE = \frac{ORR}{FRR} \times 100\%$$

## **9 Measurements and reporting**

### **9.1 General**

This clause summarizes those measurements that are to be recorded in the final report.

### **9.2 Oil properties**

The following test oil properties shall be measured prior to testing:

- viscosity (in centiPoise) at the test temperature and at 20 °C (for comparison purposes), at shear rates of 1 s<sup>-1</sup>, 10 s<sup>-1</sup> and 100 s<sup>-1</sup>, with at least two of these rates being measured with the third permitted to be determined by extrapolation;
- density (in kilograms per litre) at the test temperature and at 20 °C;
- pour point (in degrees Celsius);
- wax content (in percent);
- water content (in percent).

After testing, the water content of the recovered oil shall be measured to determine the EF.

### 9.3 Environmental parameters

The following environmental parameters shall be measured and recorded for each test:

- air temperature (in degrees Celsius);
- water temperature (in degrees Celsius);
- current velocity upstream of the oil slick (m/s).

### 9.4 Skimmer operating parameters

The settings of the skimmer operating parameters shall be reported. Examples include

- the speed of adhesion surfaces,
- the pump speed,
- drafts, and
- angles.

### 9.5 Other test parameters

Other test parameters that shall be recorded include

- the oil distribution rate (in cubic metres per hour),
- clearances to sides and tank bottom (in metres),
- the oil slick thickness (in millimetres), and
- the slick length (in metres).

### 9.6 Recovery parameters

For each measurement, the following shall be recorded:

- total recovered fluid (in cubic metres),
- recovered oily phase (in cubic metres),
- recovered water (in cubic metres),
- duration of measuring period (in minutes).

### 9.7 Performance parameters (calculated parameters)

Based on the recovery parameters, the following performance parameters shall be calculated and reported (see Clause 8):

- the fluid recovery rate (FRR);
- the oil recovery rate (ORR);
- the recovery efficiency (RE);
- the emulsification factor (EF).

## 9.8 Equipment specification and test documentation

The test report shall include a technical specification of the skimmer unit tested and a narrative of the test process. At a minimum, the technical specification shall include descriptions of the physical dimensions, construction materials, operating principle and power unit.

## 10 Quality control

### 10.1 Test duration and fluid volume

The test measuring period (period that recovered oil is collected in the measuring tank) shall be of sufficient duration to

- a) even out possible variations in test conditions during the measuring period,
- b) provide a sufficient volume of recovered product to allow for accurate reading of both oil and water volumes, and
- c) perform the monitoring and recording requirements.

Table 3 specifies the minimum duration of the data collection period and the corresponding minimum recovered fluid volume for different expected skimming capacities (FRR). The prescribed fluid volumes and collection periods apply to each measuring tank.

**Table 3 — Minimum duration of data collection and recovered fluid volume for expected FRR**

Expected FRR m <sup>3</sup> /h	Min. recovered fluid volume m <sup>3</sup>	Min. data collection period min
5	0,5	6
10	0,5	3
20	0,5	1,5
50	0,8	1
100	1,7	1
150	2,5	1
200	3,3	1
300	5	1

### 10.2 Repetition

Performance data shall be based on a minimum of three tests performed under the same test conditions with an ORR standard deviation of less than 15 %.

Individual tests shall be rejected if the individual test ORR deviates by more than 20 % from the mean.

## Annex A (informative)

### Guidelines for controlling the thickness of a contained oil slick under the influence of water current

This annex provides guidelines for controlling the thickness of an oil layer contained in a boom. The method does not replace the need for *in situ* oil slick thickness measurements, but is designed as a supplement to such measurements, since few methods are currently available for rapid and reliable slick thickness measuring.

It is based on previous studies that have indicated the following.

The thickness of the slick in a boom is nearly uniform, with the exception of some thinning at the slick's leading edge and very close to the boom. This is proven through measurements in the viscosity range 200 to 10 000 cP and at current velocities above 0,15 m/s. For conditions outside this range, empirical data are not available.

There is a direct relationship between the slick length and the slick thickness, and this relationship is unique for each oil type.

Controlling the length of the slick and the current velocity can approximately control the slick thickness.

The relationship between slick thickness and slick length (as determined by experiments) is given in the graphs below for 200 cP, 2 000 cP and 10 000 cP bunker oil with a density in the 0,93 to 0,95 range. These are meant as indications, and deviations will occur as a result of variations in density and other properties.

To obtain a specified slick thickness, the following steps are suggested.

- a) Identify the viscosity of the test oil.
- b) From Figures A.1 and A.2, identify the combination of current and slick length that will produce the desired slick thickness.
- c) Identify the amount of oil to be preloaded in the tank. This is calculated as *slick length* × *slick thickness* × *tank width*.
- d) Start the current and adjust to the desired speed.
- e) Preload the test tank with the required oil quantity.
- f) Measure the slick length and slick thickness. If found to deviate from the desired thickness, adjust by either removing oil or increasing the oil quantity.
- g) When the desired thickness is achieved, measure the length of the slick.
- h) Start the skimmer.
- i) Start the oil distribution system.
- j) Throughout testing, adjust the pumping rate of the oil distribution system to maintain the location of the slick leading edge.
- k) Verify that the slick thickness is maintained by measurements, and adjust the slick length if required.

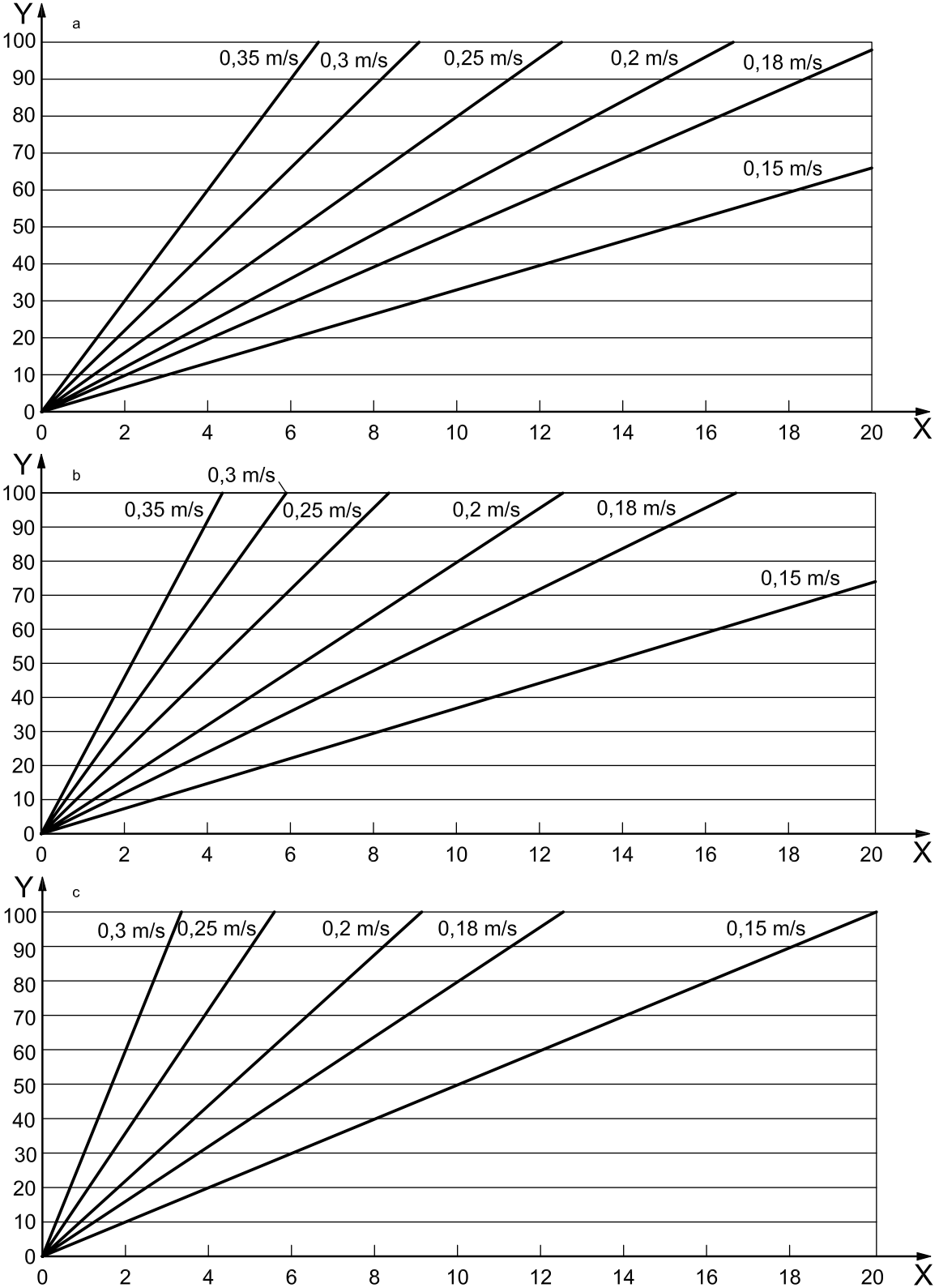

**Key**

X	oil slick length, m	a	200 cP oil.
Y	oil slick thickness, mm	b	2 000 cP oil.
		c	10 000 cP oil.

**Figure A.1 — Relationship between slick length and thickness for oil of 200 cP, 2 000 cP and 10 000 cP viscosity**

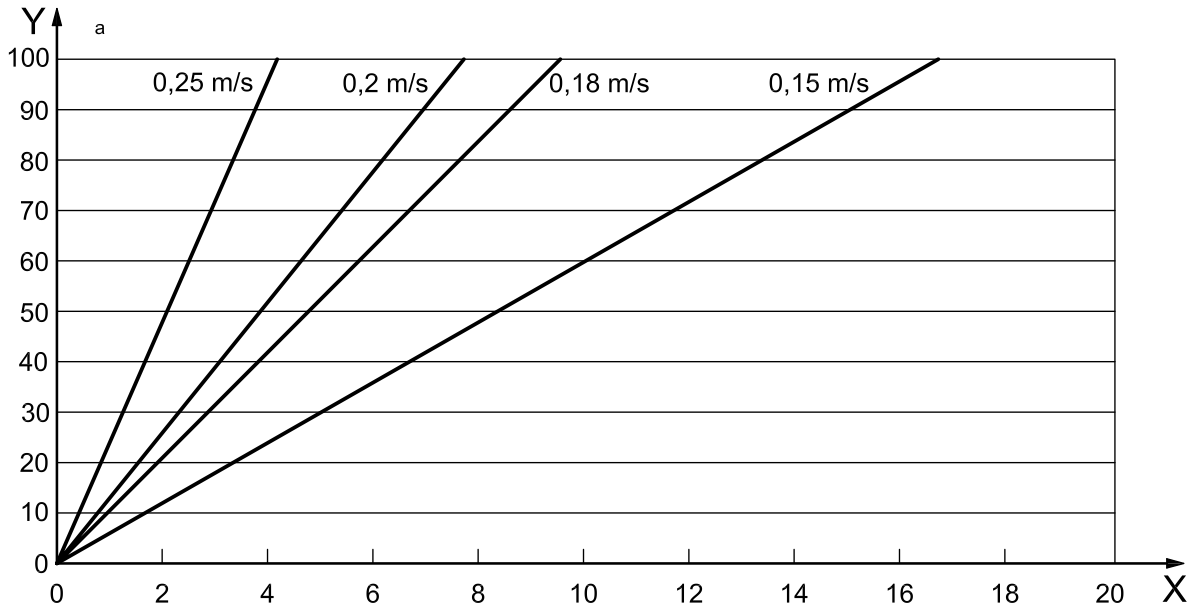

**Key**

X oil slick length, m  
Y oil slick thickness, mm

<sup>a</sup> Emulsion: 10 000 cP.

**Figure A.2 — Relationship between slick length and thickness for 10 000 cP viscosity, without emulsion of bunker oil (at  $10 \text{ s}^{-1}$ )**

## Bibliography

- [1] ISO 3733, *Petroleum products and bituminous materials — Determination of water — Distillation method*
- [2] ASTM D95-05e1, *Standard Test Method for Water in Petroleum Products and Bituminous Materials by Distillation*
- [3] ASTM D6304-07, *Standard Test Method for Determination of Water in Petroleum Products, Lubricating Oils, and Additives by Coulometric Karl Fischer Titration*
- [4] Standard for Performance Testing of Oil Spill Skimmers, *Det Norske Veritas*, 2002

---

---

**ICS 13.020.99; 47.020.99**

Price based on 15 pages





---

## BSI - British Standards Institution

BSI is the independent national body responsible for preparing British Standards. It presents the UK view on standards in Europe and at the international level. It is incorporated by Royal Charter.

### Revisions

British Standards are updated by amendment or revision. Users of British Standards should make sure that they possess the latest amendments or editions.

It is the constant aim of BSI to improve the quality of our products and services. We would be grateful if anyone finding an inaccuracy or ambiguity while using this British Standard would inform the Secretary of the technical committee responsible, the identity of which can be found on the inside front cover. Tel: +44 (0)20 8996 9000. Fax: +44 (0)20 8996 7400.

BSI offers members an individual updating service called PLUS which ensures that subscribers automatically receive the latest editions of standards.

### Buying standards

Orders for all BSI, international and foreign standards publications should be addressed to Customer Services. Tel: +44 (0)20 8996 9001. Fax: +44 (0)20 8996 7001 Email: [orders@bsigroup.com](mailto:orders@bsigroup.com) You may also buy directly using a debit/credit card from the BSI Shop on the Website <http://www.bsigroup.com/shop>

In response to orders for international standards, it is BSI policy to supply the BSI implementation of those that have been published as British Standards, unless otherwise requested.

### Information on standards

BSI provides a wide range of information on national, European and international standards through its Library and its Technical Help to Exporters Service. Various BSI electronic information services are also available which give details on all its products and services. Contact Information Centre. Tel: +44 (0)20 8996 7111 Fax: +44 (0)20 8996 7048 Email: [info@bsigroup.com](mailto:info@bsigroup.com)

Subscribing members of BSI are kept up to date with standards developments and receive substantial discounts on the purchase price of standards. For details of these and other benefits contact Membership Administration. Tel: +44 (0)20 8996 7002 Fax: +44 (0)20 8996 7001 Email: [membership@bsigroup.com](mailto:membership@bsigroup.com)

Information regarding online access to British Standards via British Standards Online can be found at <http://www.bsigroup.com/BSOL>

Further information about BSI is available on the BSI website at <http://www.bsigroup.com>

### Copyright

Copyright subsists in all BSI publications. BSI also holds the copyright, in the UK, of the publications of the international standardization bodies. Except as permitted under the Copyright, Designs and Patents Act 1988 no extract may be reproduced, stored in a retrieval system or transmitted in any form or by any means – electronic, photocopying, recording or otherwise – without prior written permission from BSI.

This does not preclude the free use, in the course of implementing the standard, of necessary details such as symbols, and size, type or grade designations. If these details are to be used for any other purpose than implementation then the prior written permission of BSI must be obtained.

Details and advice can be obtained from the Copyright and Licensing Manager. Tel: +44 (0)20 8996 7070 Email: [copyright@bsigroup.com](mailto:copyright@bsigroup.com)