



BSI Standards Publication

Cigarettes — Determination of carbon monoxide in sidestream smoke — Method using a routine analytical linear smoking machine equipped with a fishtail chimney

National foreword

This British Standard is the UK implementation of ISO 20774:2013. It supersedes BS ISO 20774:2007 which is withdrawn.

The UK participation in its preparation was entrusted to Technical Committee AW/40, Tobacco and tobacco products.

A list of organizations represented on this committee can be obtained on request to its secretary.

This publication does not purport to include all the necessary provisions of a contract. Users are responsible for its correct application.

© The British Standards Institution 2013. Published by BSI Standards Limited 2013

ISBN 978 0 580 74581 2

ICS 65.160

Compliance with a British Standard cannot confer immunity from legal obligations.

This British Standard was published under the authority of the Standards Policy and Strategy Committee on 30 September 2013.

Amendments issued since publication

Date	Text affected
------	---------------

Cigarettes — Determination of carbon monoxide in sidestream smoke — Method using a routine analytical linear smoking machine equipped with a fishtail chimney

Cigarettes — Détermination du monoxyde de carbone dans le courant secondaire de fumée — Méthode utilisant une machine à fumer analytique de routine linéaire équipée d'une cheminée individuelle en forme de queue de poisson





COPYRIGHT PROTECTED DOCUMENT

© ISO 2013

All rights reserved. Unless otherwise specified, no part of this publication may be reproduced or utilized otherwise in any form or by any means, electronic or mechanical, including photocopying, or posting on the internet or an intranet, without prior written permission. Permission can be requested from either ISO at the address below or ISO's member body in the country of the requester.

ISO copyright office
Case postale 56 • CH-1211 Geneva 20
Tel. + 41 22 749 01 11
Fax + 41 22 749 09 47
E-mail copyright@iso.org
Web www.iso.org

Published in Switzerland

Contents

Page

Foreword	iv
Introduction	v
1 Scope	1
2 Normative references	1
3 Terms and definitions	1
4 Principle	2
5 Apparatus	2
6 Reagents	5
6.1 Standard gas mixtures.....	5
7 Sampling and preparation of cigarettes	6
7.1 General.....	6
7.2 Symbols.....	6
7.3 Preparation of the cigarettes for smoking.....	6
7.4 Selection of test portions of cigarettes.....	6
7.5 Marking the butt length.....	7
7.6 Conditioning.....	8
7.7 Preliminary tests before smoking.....	8
8 Preparation for the smoking run	8
8.1 Smoking plan.....	8
8.2 Preparation of mainstream and sidestream smoke traps and cigarette holders.....	8
8.3 Setting up the smoking machine.....	9
8.4 Assembly of fishtail chimney and sidestream smoke trap.....	9
9 Procedure for smoking run and collection of sidestream smoke	10
9.1 Preparation of fishtail chimney.....	10
9.2 Setting the fishtail chimney flow rate.....	10
9.3 Connection of sidestream smoke filter pad holders.....	10
9.4 Record the atmospheric conditions.....	10
9.5 Loading the cigarettes.....	10
9.6 Smoking the cigarettes.....	10
10 Determination of carbon monoxide	11
10.1 General principles.....	11
10.2 Calculation of CO yields using an off-line (bag collection) system.....	11
10.3 Calculation of carbon monoxide on an on-line (continuous flow) data acquisition system.....	12
11 Summary of other test sample calculations	13
12 Test report	14
12.1 General.....	14
12.2 Characteristic data about the cigarette.....	14
12.3 Data about sampling.....	15
12.4 Description of test.....	15
12.5 Test results.....	15
13 Repeatability and reproducibility	16
Annex A (informative) Smoking plans	17
Annex B (informative) Alternative procedure for CO calibration	21
Bibliography	22

Foreword

ISO (the International Organization for Standardization) is a worldwide federation of national standards bodies (ISO member bodies). The work of preparing International Standards is normally carried out through ISO technical committees. Each member body interested in a subject for which a technical committee has been established has the right to be represented on that committee. International organizations, governmental and non-governmental, in liaison with ISO, also take part in the work. ISO collaborates closely with the International Electrotechnical Commission (IEC) on all matters of electrotechnical standardization.

The procedures used to develop this document and those intended for its further maintenance are described in the ISO/IEC Directives, Part 1. In particular the different approval criteria needed for the different types of ISO documents should be noted. This document was drafted in accordance with the editorial rules of the ISO/IEC Directives, Part 2. www.iso.org/directives

Attention is drawn to the possibility that some of the elements of this document may be the subject of patent rights. ISO shall not be held responsible for identifying any or all such patent rights. Details of any patent rights identified during the development of the document will be in the Introduction and/or on the ISO list of patent declarations received. www.iso.org/patents

Any trade name used in this document is information given for the convenience of users and does not constitute an endorsement.

The committee responsible for this document is ISO/TC 126, *Tobacco and tobacco products*.

This second edition cancels and replaces the first edition (ISO 20774:2007) which has been editorially revised.

Introduction

Cigarettes are manufactured to close tolerances using strict quality control procedures.

However, the main constituents involved in the manufacture are derived from natural products (such as tobacco and paper) and this results in a final product which is intrinsically variable. Further complexity arises as the cigarette is combusted during smoking to yield the cigarette smoke.

The quantitative measurement of carbon monoxide is therefore dependent on the arbitrary definition of the means used to generate and collect the smoke. In particular, the ambient conditions (e.g. temperature, humidity, air movement within the laboratory) under which the test pieces are conditioned and smoke is collected play a critical role in the accuracy of the measurement.

Sidestream smoke in this International Standard is understood to be the smoke that is evolved from the cigarette during the smoking run other than from the mouth end (which is called mainstream smoke).

NOTE Side stream smoke is distinguished from environmental tobacco smoke (ETS), which is a mixture of aged and diluted exhaled mainstream smoke and aged and diluted sidestream smoke, and for the assessment of which the present method does not apply.

From the time that scientists have attempted to determine carbon monoxide yields in sidestream smoke, many different methods have been adopted. However, experience has shown some procedures to be more reliable and more amenable to handling of large numbers of samples. With these factors in mind, during the 1999–2002 period, collaborative studies by a task force composed of CORESTA (www.coresta.org) members have shown that improvements in repeatability and reproducibility result when some restrictions are placed upon the wide variety of methods and practices described in existing methods.

This International Standard, produced after much collaborative experimentation by many laboratories in many countries, reflects the results of the optimization proposed and validated by the task force and provides one set of procedures that are the accepted reference procedures and for which repeatability and reproducibility of the determinations were assessed. Experience in the task force has shown how strict adherence to the detailed set up and conditions of the method, as well as the degree of proficiency of the operator, affect the precision of the results.

Further, it is preferable that the selected method be compatible with different modes of cigarette equilibration or puffing parameters for the smoking of the tested pieces. The standards defined by ISO for the determination of mainstream smoke yields were, however, followed to the largest possible extent, although the machines used by the different laboratories were all of a linear type.

This method is a machine method and it allows cigarettes to be smoked using a strictly controlled set of parameters. Thus it enables the sidestream smoke carbon monoxide yields from cigarettes, when smoked by this procedure, to be compared and ranked. In the course of its studies, the task force demonstrated the value of comparing the analytical processes and their stability by use of the CORESTA monitor test piece for determining sidestream smoke CO yields.

Since the determination of sidestream smoke CO yield is by nature more complex and delicate than its counterpart performed on mainstream smoke, it is highly recommended to include a monitor test piece in the smoking plans, as is done in mainstream smoke determinations. It is possible to use the CORESTA monitor or any other internally designed monitor test piece for this purpose. The use of an internationally recognized one is recommended.

Cigarettes — Determination of carbon monoxide in sidestream smoke — Method using a routine analytical linear smoking machine equipped with a fishtail chimney

WARNING — The use of this International Standard can involve hazardous materials, operations and equipment. This International Standard does not purport to address all the safety problems associated with its use. It is the responsibility of the user of this International Standard to establish appropriate safety and health practices and determine the applicability of regulatory limitations prior to use.

1 Scope

This International Standard is applicable to the determination of carbon monoxide present in the sidestream smoke from cigarettes. The described method is specified using the ISO 3308 smoking parameters (puff volume, duration and frequency) and butt length, but it is technically compatible with other smoking regimes.

NOTE The method may not be directly adaptable to other sidestream smoke analytes. Nevertheless the determination of carbon dioxide was part of the validation study of ISO 20774 carried out by CORESTA. According to the number of reporting laboratories no rigorous statistical analysis of sidestream carbon dioxide data was carried out. Therefore only indicative information about conditions for the determination of CO₂ is provided.

2 Normative references

The following documents, in whole or in part, are normatively referenced in this document and are indispensable for its application. For dated references, only the edition cited applies. For undated references, the latest edition of the referenced document (including any amendments) applies.

ISO 2971, *Cigarettes and filter rods — Determination of nominal diameter — Method using a non-contact optical measuring apparatus*

ISO 3308, *Routine analytical cigarette-smoking machine — Definitions and standard conditions*

ISO 3402, *Tobacco and tobacco products — Atmosphere for conditioning and testing*

ISO 4387, *Cigarettes — Determination of total and nicotine-free dry particulate matter using a routine analytical smoking machine*

ISO 6488, *Tobacco and tobacco products — Determination of water content — Karl Fischer method*

ISO 6565, *Tobacco and tobacco products — Draw resistance of cigarettes and pressure drop of filter rods — Standard conditions and measurement*

ISO 8454:2007, *Cigarettes — Determination of carbon monoxide in the vapour phase of cigarette smoke — NDIR method*

3 Terms and definitions

For the purposes of this document, the following terms and definitions apply.

3.1

sidestream smoke vapour phase

portion of the sidestream smoke which passes through a Cambridge filter pad under the conditions specified in the method

3.2
smoking process

use of a smoking machine to smoke cigarettes from lighting to final puff

3.3
smoking run

specific smoking process to produce such sidestream smoke from a sample of cigarettes as is necessary for the determination of the smoke components

3.4
laboratory sample

sample intended for laboratory inspection or testing and which is representative of the gross sample or the sub-period sample

3.5
test sample

cigarettes for test taken at random from the laboratory sample and which are representative of each of the increments making up the laboratory sample

3.6
conditioning sample

cigarettes selected from the test sample for conditioning prior to tests for sidestream smoke CO yield

3.7
test portion

group of cigarettes prepared for a single determination and which is a random sample from the test sample or conditioning sample, as appropriate

3.8
monitor test piece

sample produced for a specific test purpose, validated to fulfil requirements within specified tolerances and intended to be used for laboratory purposes only and labelled to clearly indicate that it is not for human use

Note 1 to entry: A monitor test piece is a sample taken from a batch of cigarettes that show the greatest homogeneity with regard to their physical, chemical and smoke yield characteristics.

4 Principle

- Sampling of the test cigarettes.
- Conditioning of the test cigarettes.
- Smoking of the test cigarettes on a smoking machine in accordance with ISO 3308, with the exception of the specifications on air velocity control, and equipped with a fishtail chimney and a filter pad (glass fibre filter pad) for sidestream smoke collection from each channel.
- Collection of sidestream smoke vapour phase and determination of its CO content.

NOTE The determination of the CO content can be done either by an on-line measurement or by off-line measurement. In the latter method, the vapour phase, or a proportion of it, is first collected in a gas bag.

5 Apparatus

Usual laboratory apparatus and in particular the following items.

5.1 Fishtail chimney¹⁾, manufactured in glass, of design and dimensions shown in [Figure 1](#).

1) Details of where to obtain fishtail chimneys are available from ISO/TC 126.

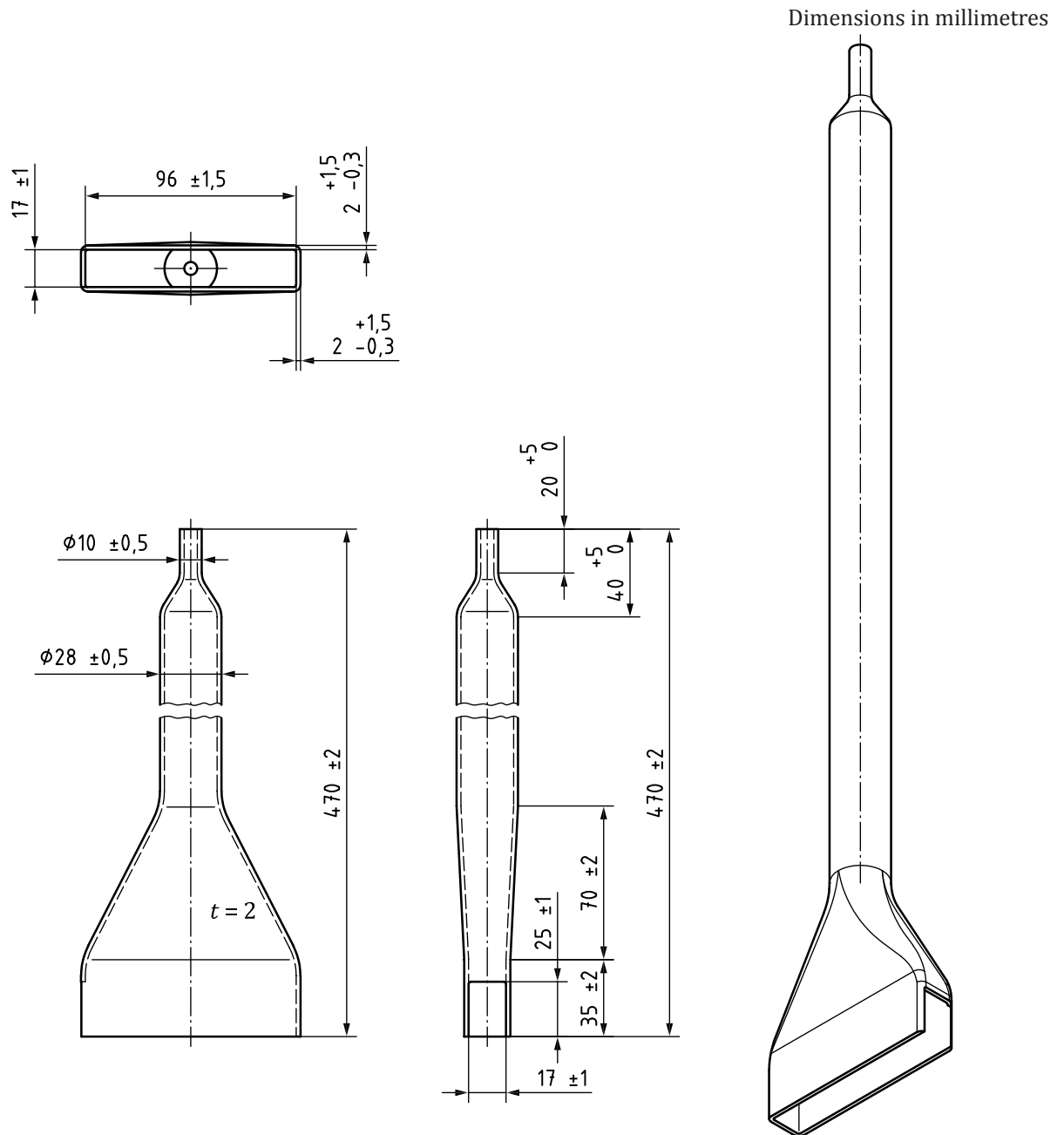
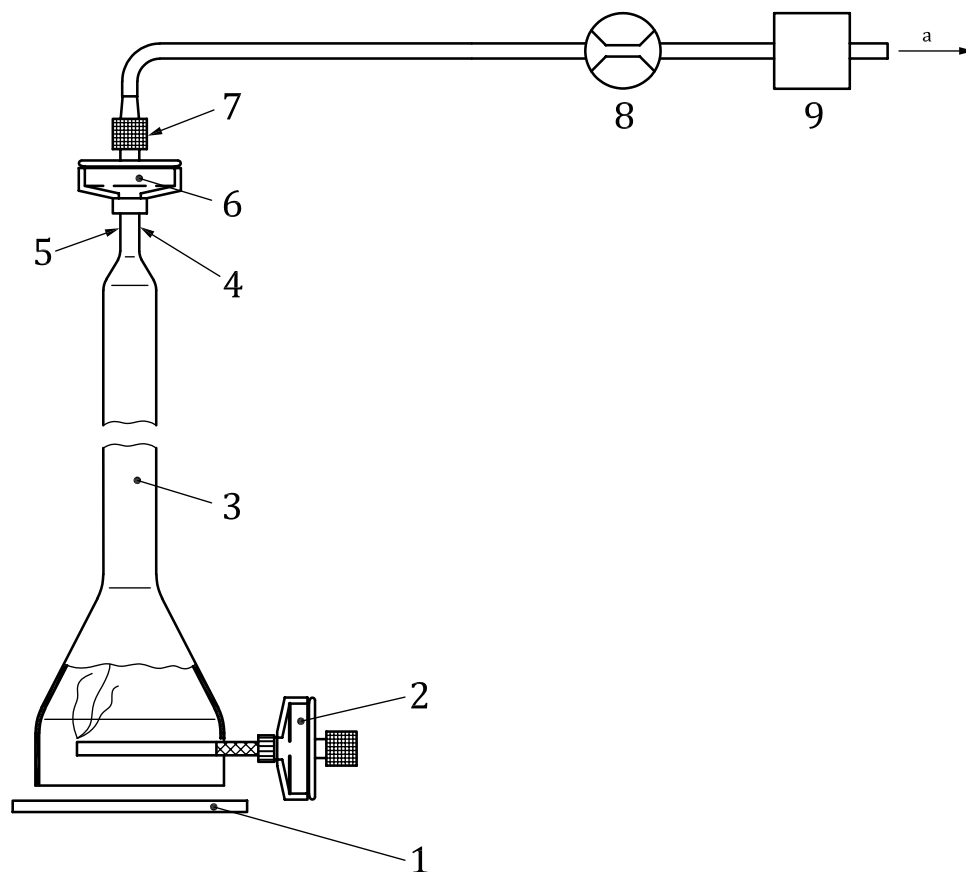

Figure 1 — Fishtail chimney dimensions

5.2 Routine analytical cigarette-smoking machine, modified to accept fishtail chimneys and complying with the requirements of ISO 3308 with the exception of the specifications on air velocity control. A plate shall be fixed underneath each channel, with a minimum length of 120 mm and a minimum width of 50 mm. This plate is positioned so as to cover the totality of the opening at the fishtail chimney bottom, as shown in [Figure 2](#).



- Key**
- 1 horizontal plate
 - 2 mainstream smoke trap and cigarette holder
 - 3 fishtail chimney
 - 4 location of calibration flow measurement
 - 5 pressure and vacuum tubing
 - 6 sidestream smoke trap
 - 7 quick connect
 - 8 flow meter
 - 9 flow regulator
 - a To vacuum pump and CO collection/detector.

Figure 2 — Sidestream smoke collection system

5.3 Non-dispersive infrared (NDIR) analyser, selective and calibrated for the measurement of carbon monoxide in vapours and gases.

Analysers are available from several manufacturers and should have a preferred working range of a volume fraction of 0 % to 2 % with a linear output. The analyser should have a precision of 1 % of full scale, a linearity of 1 % of full scale, and a repeatability of 0,2 % of full scale, under conditions of constant temperature and pressure. The signal generated by a volume fraction of 10 % of carbon dioxide should not exceed a volume fraction of 0,05 % as carbon monoxide. Its response to a volume fraction of 2 % of water vapour should not exceed a volume fraction of 0,02 % as carbon monoxide.

5.4 Gas sampling bags, needed only if vapour phase collection is done in bags rather than by a continuous flow system.

When a bag is used as the gas-collecting device, it should be large enough to avoid the final pressure of its contents exceeding the ambient atmospheric pressure. The volume of the bag shall also be no greater than twice the volume of the gas content collected at atmospheric pressure.

Collection bag material shall be suitable for carbon monoxide and also for carbon dioxide if it is intended to determine the latter. Tedlar bags are suitable for CO analysis, but will allow carbon dioxide to gradually leak out upon storage, so that their use would mandate an immediate quantification of the latter. Saran has been shown to be an effective material for the sampling of both gases.

5.5 Vacuum pump or pumps and flow control devices, capable of maintaining an air flow of 3 l/min through each fishtail chimney and collection train.

5.6 PVC tubing, tubing of approximately 8 mm inside diameter, 11 mm outside diameter, to connect the sidestream smoke trap, in-line flow meter, flow regulator, vacuum pump, gas sampling bag (if used) and CO analyser.

5.7 Timer, stopwatch, clock or timing device capable of measuring the elapsed time in seconds.

5.8 Flow monitoring and regulating system on each channel, comprising an in-line continuous-reading flow meter, capable of monitoring the flow with a resolution of 0,2 l/min, followed by a precision flow-regulating device.

5.9 Primary flow meter, capable of accurately measuring a flow-rate of 3 l/min to a precision of 0,1 l/min, to be used in setting the air flow in each fishtail chimney before a smoke run. As this is a primary measurement, the flow meter should measure the time needed to flush a known volume.

5.10 Soap bubble flow meter or alternative displacement flow meter, capable of measuring a displaced volume of at least the desired puff volume, with an accuracy of $\pm 0,2$ ml and a resolution of 0,1 ml.

5.11 Apparatus for the determination of puff duration and frequency.

5.12 Analytical balance, with a resolution of 0,1 mg.

5.13 Draw resistance testing equipment, as specified in ISO 6565.

5.14 Conditioning enclosure, carefully maintained in accordance with the conditions specified in ISO 3402.

5.15 Length-measuring device, suitable for measuring to the nearest 0,5 mm.

5.16 Apparatus for the determination of diameter, in accordance with ISO 2971.

5.17 Barometer, capable of measuring atmospheric pressures to the nearest 0,1 kPa.

6 Reagents

Use only reagents of recognized analytical reagent grade.

6.1 Standard gas mixtures

Nominally: 0,20 % carbon monoxide in nitrogen

Nominally: 0,75 % carbon monoxide in nitrogen

Gas standards with actual values within 25 % of the above are acceptable.

Other gas standards may be used, when alternative calibration procedures are adopted.

The precision of the concentration of gas standard mixture should be 3 % relative or better.

NOTE If carbon dioxide is also to be determined, it is recommended that nominally: 0,70 % carbon dioxide, and nominally: 2,00 % CO₂ standard gas mixes be used. In this case calibration gases may be a mixture of carbon monoxide and carbon dioxide, with concentrations as described above. Laboratory grade nitrogen or synthetic air is to be used for zeroing the analysers.

7 Sampling and preparation of cigarettes

7.1 General

Provide a laboratory sample (see 3.4), by using a suitable sampling scheme. Guidance may be found in ISO 8243.

7.2 Symbols

In 7.3, 7.4 and 8.1, the symbols listed in Table 1 are used.

Table 1 — Symbols used

Symbol	Variable
<i>N</i>	Number of cigarettes to be smoked.
<i>C</i>	Multiplying factor, value greater than 1, to allow for loss due to damage or selection procedures between initial sampling and smoking.
<i>n</i>	Number of replicate determinations of total sidestream smoke particulate matter.
<i>q</i>	Number of cigarettes smoked into the same sidestream smoke trap.
<i>P</i>	Total number of packets of cigarettes available.
<i>Q</i>	Total number of cigarettes available (laboratory sample, see 3.4).

7.3 Preparation of the cigarettes for smoking

If *N* cigarettes are to be smoked, $C \times N$ cigarettes should be prepared from *Q* for conditioning and butt marking. The multiplier *C* is usually at least 1,2 to provide extra cigarettes in case some are damaged. If a selection by mass or draw resistance (or any other parameter) is necessary because of the nature of the problem being studied, the selection is not to be considered as a method of reducing the number of cigarettes to be smoked. Therefore *C* will have to be much larger (experience suggests 2,0 to 4,0) depending on the selection process.

NOTE The precision data given in this method are based on eight replicates of three cigarettes. Any reduction in the number of replicates will affect the precision. It is not recommended to smoke less than five replicates.

The *N* cigarettes to be smoked will be tested in $n = N/q$ determinations if *q* cigarettes are smoked into one trap. As far as possible these *n* determinations should correspond to different test portions of the test sample. Selection of each test portion will depend upon the form of the test sample.

7.4 Selection of test portions of cigarettes

7.4.1 Selection of test portions from a bulk of *Q* cigarettes

If the test sample is in the form of a single bulk consisting of *Q* cigarettes, $C \times N$ cigarettes should be selected at random so that every cigarette has an equal probability of being chosen.

7.4.2 Selection of test portions from P packets

If the test sample consists of P packets, the selection procedure depends upon the number of cigarettes in each packet (Q/P) compared with q .

If $Q/P \geq C \times q$, select a test portion by choosing a single packet at random, then randomly select $C \times q$ cigarettes from that packet.

If $Q/P < C \times q$, select the smallest number of packets, k , such that

$$Q \times k/P \geq C \times q$$

and randomly choose an equal (or as near equal as possible) number of cigarettes from each packet to form the test portion of $C \times q$ cigarettes.

7.4.3 Duplicate test portions

Provided that the test sample is sufficiently large ($\geq 2 C \times N$), it would be prudent to reserve a duplicate set of n test portions. In this event the parallel selection of a test portion and its duplicate would seem sensible. In this case the two selection conditions of [7.4.2](#) would need to be changed to

$$Q/P \geq 2 C \times q \text{ and } Q/P < 2 C \times q$$

7.5 Marking the butt length

7.5.1 Standard butt length

The standard butt length to which cigarettes shall be marked shall be the greatest of the following three lengths:

- 23 mm,
- length of filter + 8 mm,
- length of overwrap + 3 mm,

where the overwrap is defined as any wrapper applied to the mouth end of the cigarette and the length of the filter is defined as the total length of the cigarette minus the length of the tobacco portion.

NOTE The butt length is defined in ISO 3308 as the length of unburnt cigarette remaining at the moment when smoking is stopped.

7.5.2 Measurement of length of filter

The length of filter as defined in [7.5.1](#) shall be the mean value of 10 cigarettes taken from the laboratory sample measured to an accuracy of 0,5 mm. The mean shall be expressed to the nearest 0,5 mm.

NOTE In some instances, it may be necessary to measure more than 10 cigarettes, but when the variation in filter length can be demonstrated to be well controlled, a smaller number of measurements may be sufficient.

7.5.3 Measurement of length of overwrap

The length of overwrap as defined in [7.5.1](#) shall be the mean value of 10 overwraps taken from the laboratory sample measured to an accuracy of 0,5 mm. The mean shall be expressed to the nearest 0,5 mm.

NOTE In some instances, it may be necessary to measure more than 10 cigarettes, but when the variation in overwrap length can be demonstrated to be well controlled, a smaller number of measurements may be sufficient.

7.5.4 Butt length to be marked on the cigarettes before conditioning

Draw a line, using a fine soft-tipped marker, at the standard butt length, to an accuracy of 0,5 mm from the mouth end for the particular cigarette type.

Care should be taken to avoid damaging the cigarettes during butt marking. Any cigarettes accidentally torn or punctured during marking, or any found during marking to be defective, shall be discarded and replaced with spare cigarettes from the test portion.

If cigarettes are to be smoked on a smoking machine on which the butt length in accordance to [7.5.1](#) can be pre-set, it is not necessary to mark the butt lengths on the cigarettes themselves.

7.6 Conditioning

Condition all the test portions in the conditioning atmosphere specified in ISO 3402 for a minimum of 48 h and a maximum of 10 d.

If for any reason test samples are to be kept longer than 10 d before conditioning, store them in original packaging or in airtight containers just large enough to contain the sample.

The testing atmosphere in the laboratory where the smoking is to be carried out shall also be in accordance with ISO 3402.

Transfer the test portions to the smoking location in airtight containers (just large enough to contain the portions) unless the smoking location and the conditioning location are adjoining and have identical atmospheres.

7.7 Preliminary tests before smoking

The following data may be required in the test report:

- a) total length of the cigarette;
- b) nominal diameter determined in accordance with ISO 2971;
- c) draw resistance of the cigarette determined in accordance with ISO 6565;
- d) average mass of the conditioned cigarettes selected for the smoking operation, in milligrams per cigarette;
- e) water content, as a mass fraction in percent, of the conditioned cigarettes in accordance with ISO 6488.

8 Preparation for the smoking run

8.1 Smoking plan

Choose a smoking plan; examples are given in [Annex A](#).

The plan should show the number of cigarettes to be smoked into each trap, q .

8.2 Preparation of mainstream and sidestream smoke traps and cigarette holders

For all operations the operator shall prevent contamination from the fingers by wearing gloves of a suitable material.

Prepare the mainstream smoke traps and cigarette holders in accordance with ISO 3308.

Insert into the sidestream smoke trap filter pads that have been conditioned in the test atmosphere for at least 12 h, and assemble, placing the rough side of the filter pad so that it will face the oncoming smoke. Assemble the filter holder making sure that the conditioned filter pad is fitted correctly.

8.3 Setting up the smoking machine

Set up the smoking machine in accordance with ISO 4387.

8.4 Assembly of fishtail chimney and sidestream smoke trap

8.4.1 General

Each fishtail chimney shall be attached to an adjustable-height mounting block in such a way that it is securely held. Depending on the type of smoking machine and the degree of automation available, the mounting block may be manually or automatically raised and lowered. In its lowered position, the bottom of the fishtail chimney shall be at a distance of 6 mm from the horizontal plate of the smoking machine. The raised position shall be at a height sufficient for convenient access for loading cigarettes and removing extinguished butts.

NOTE An intermediate position can be used for lighting the cigarettes while maintaining the fishtail as close as possible to the cigarettes. A distance of about 60 mm above the horizontal plate has been found to be suitable.

The sidestream smoke filter pad holder is attached to the top of the fishtail chimney by means of a suitable connector or a short piece of vacuum tubing.

8.4.2 Calibration procedure

Adjust the analysers to read zero while purging the measuring cell at the required flow rate.

Introduce the high gas (nominally 0,75 % CO) to the analysers. Allow the digital display to stabilize and then set the analyser span. Once the analyser span is set, take a reading of the concentration for the high gas.

Introduce the low gas (nominally 0,20 % CO) and allow the digital display to stabilize. Take a reading of the concentration for the low gas.

The design of the calibrated flow meter must be such that it does not introduce a significant flow impedance (i.e. additional pressure drop) at a flow of 3 l/min.

The calibration gases can be sampled into the gas analysers either directly from a continuous flow from the gas cylinders, or indirectly from gas sampling bags previously filled from the cylinders. It is very important to make sure that the gas pressure in the measurement cell of the analysers during calibration is the same as when measurements are subsequently made on the sidestream smoke vapour phase. It is good practice to keep the gas pressure in the measurement cell as near to atmospheric pressure as possible by leaving its outlet directly open to the atmosphere, excluding any pump or flow restriction.

NOTE 1 For CO₂ determinations, a background reading from laboratory air should be performed to correct for the presence of carbon dioxide in the air when the bag collection method is used.

NOTE 2 It is good practice when using a needle valve to control the airflow and a float type flow meter to monitor the set flow, to have the needle valve downstream of the flow meter ([Figure 2](#)).

Plot a calibration curve of the average response factors from each calibration gas versus the concentrations of the gas mixtures used (nominally 0 %, 0,20 %, 0,75 % CO). A linear regression should be performed on the data set.

8.4.3 Alternative calibration procedure

Other procedures for calibration may be adopted. For example the calibration gas mixture may be fed at a rate distinctly lower than 3 l/min into the fishtail and then via the pump to the CO detector. The gas may be supplied from a compressed gas cylinder, or by other means (see schematic in [Figure B.1](#)). If the CO detector signal is recorded by an integrator, "peak" area can be calibrated against CO volume.

9 Procedure for smoking run and collection of sidestream smoke

9.1 Preparation of fishtail chimney

Secure each fishtail chimney in its lower position, measuring the distance from the horizontal plate with a suitable 6 mm spacer. Raise the chimney to its upper position.

9.2 Setting the fishtail chimney flow rate

Switch on the vacuum pumps. By means of the associated flow indicator and needle valve, adjust the flow through each sidestream smoke filter pad holder to $(3,0 \pm 0,1)$ l/min, using a suitable primary flow meter attached to the inlet of the sidestream smoke filter pad holder. Switch off the vacuum pumps.

9.3 Connection of sidestream smoke filter pad holders

Attach each sidestream smoke trap securely to its fishtail chimney by means of a short piece of vacuum tubing or suitable connector.

9.4 Record the atmospheric conditions

Measure the temperature and relative humidity in the laboratory where the smoking is carried out and note the atmospheric pressure.

9.5 Loading the cigarettes

Insert the conditioned cigarettes into the cigarette holders to the insertion depth recommended in ISO 3308 (9 mm). Avoid any leaks or deformation. Any cigarettes found to have obvious defects, or which have been damaged during insertion, shall be discarded and replaced with spare conditioned cigarettes.

Ensure that the cigarettes are positioned correctly so that the angle formed by the longitudinal axis of the cigarette and the horizontal plate shall be as small as possible. It shall not exceed 10° if the centre of the butt end is lower than the centre of the other end and 5° if the centre of the butt end is higher than the centre of the other end.

Adjust the position of each cigarette so that when the burning coal reaches the butt mark, the puff termination device (if applicable) is activated. If the burning through of 100 % cotton thread (48 ± 4) tex is used to terminate smoking at the butt mark, the cotton shall just touch the cigarettes at the butt mark, without modifying the cigarette positioning.

Ensure that the cigarette position is centred with respect to the fishtail, and that the fishtail covers a maximum length of the cigarette while ensuring that the distance between the end of the cigarette and the front wall of the chimney is never less than 5 mm. In the case of long cigarettes this requirement may mean that the chimney may need to be moved along the axis of the cigarette as smoking progresses, in order to ensure that the fishtail covers the butt mark of the cigarette well before this is reached. The central axis of the cigarette will be positioned at a minimum of 15 mm above the bottom edge of the fishtail chimney.

Return the fishtail chimneys to their lowest position compatible with the lighting system (a distance of about 60 mm above the fixed plate has been found suitable).

9.6 Smoking the cigarettes

Switch on the vacuum pumps and, where gas bags are to be used to collect the smoke vapour phase, simultaneously start the time recorder which will record the total time taken for the smoking run. Zero the puff counters and light each cigarette at the beginning of its first puff as specified by ISO 4387. Lower each chimney to the smoking position as quickly as possible. As each butt mark is reached, immediately raise the fishtail chimney and remove the burning coal from the cigarette. Record the final reading

of the puff counters. After the smoking process is complete, wait a minimum of 30 s after raising the chimney, in order to clear any sidestream smoke from the chimney.

If required, new cigarettes shall be inserted immediately and the smoking process repeated until the predetermined number of cigarettes (normally three) has been smoked on each channel. Allow the vacuum pump to run for a minimum of 30 s after the last cigarette has been smoked. Stop the vacuum pump and time recorder and note the elapsed time.

NOTE Avoid disturbance of the smoking by artificial removal of ash. Allow ash to fall naturally onto the horizontal plate.

10 Determination of carbon monoxide

10.1 General principles

10.1.1 Parameters

The parameters needed to calculate the sidestream smoke CO yield are the average volumetric concentration in the collected smoke vapour phase, the volumetric flow rate and the time taken for collection. The product of these three parameters, i.e. concentration × flow rate × collection time, is used to determine the total volume of carbon monoxide in the collected smoke vapour phase.

Either the on-line or the off-line method may be used to determine sidestream smoke CO yields.

10.1.2 On-line method

A large number of CO concentration measurements are recorded and mathematically averaged on-line. For on-line measurements, it is not necessary to independently record the collection time as this will be known from the data sampling rate and the number of data points included in the calculation of the average concentration.

10.1.3 Off-line method (gas bag collection)

The average sidestream smoke CO concentration is derived from a single measurement off-line, after allowing the sidestream smoke vapour phase to mix in a gas sampling bag. A single measurement is recorded for each of the three parameters – concentration, flow rate and collection time – and for each cigarette, or group of three cigarettes, smoked.

10.2 Calculation of CO yields using an off-line (bag collection) system

The volume of carbon monoxide in the sidestream smoke vapour phase collected in the bag shall be calculated from the set flow rate from each port connected to the bag, and from the duration of the smoke run, i.e. the time elapsing between switching on the pump and switching it off. The concentration of carbon monoxide (and carbon dioxide if measured) is determined by sampling the bag contents through the off-line NDIR analyser(s). This will then allow the calculation of the CO delivery in milligrams per cigarette, following the equations given in ISO 8454:2007, Clause 8, but substituting the collected sidestream smoke volume for the mainstream smoke volume as in Formula (1).

Thus,

$$V_{\text{as}} = \frac{C \times F \times R \times p \times T_0}{[S \times 100 \times p_0 \times (t + T_0)]} \quad (1)$$

where

V_{as} is the average volume of carbon monoxide per cigarette, in millilitres;

C is the percentage by volume of carbon monoxide observed;

F is the volumetric flow rate, in millilitres per second;

R is the vapour phase sampling time, in seconds;

S is the number of cigarettes smoked into the bag;

p is the ambient pressure, in kilopascals;

t is the ambient temperature, in degrees centigrade;

p_0 is the standard atmospheric pressure (101,325 kPa);

T_0 is the temperature for the critical point of water, in Kelvin (273 K).

This yield, in millilitres per cigarette, can be converted to milligrams per cigarette by applying Formula (2):

$$m_{\text{cig}} = V_{\text{as}} \times M_{\text{CO}} / V_{\text{m}} \quad (2)$$

where

m_{cig} is the average mass of carbon monoxide per cigarette, in milligrams;

M_{CO} is the molar mass of carbon monoxide, in grams per mole (28);

V_{m} is the molar volume of an ideal gas, in litres per mole (22,4).

NOTE The carbon dioxide if measured is calculated in the same way except the M_{CO_2} for carbon dioxide is 44.

10.3 Calculation of carbon monoxide on an on-line (continuous flow) data acquisition system

In the case of on-line sampling it is not appropriate to specify in detail how the data should be recorded and manipulated to calculate the volume of carbon monoxide, as there are many valid options. However an example is given here for purposes of illustration.

During data collection, read the sidestream smoke analysers at least once per second and store the collected data values in data arrays while logging the time. At the end of the run for each cigarette, store the data arrays in a data file associated with the cigarette just smoked. For analysis of these data, ensure that data points (at least 20 s) are available to calculate a baseline for the data. This baseline will be used to determine what actual data will be used in the gas calculations.

The data are integrated (for instance an average can be computed using a spreadsheet) over the time between the initial deflection of the signal and the return of the detector signal to base line. The base line level has to be subtracted. If the front and back baselines do not match, an averaged value is used. The averaged signal deflection "CO data array" is recorded. The percentage by volume of carbon monoxide is determined from this averaged signal and the calibration line.

The CO yield, in millilitres, corrected to standard temperature and pressure, is computed from the CO analyser output (expressed as per cent CO) by Formula (3):

$$V_{\text{as}} = \frac{C \times F \times R \times p \times T_0}{[S \times 100 \times p_0 \times (t + T_0)]} \quad (3)$$

where

- V_{as} is the average volume of carbon monoxide per cigarette, in millilitres;
- C is the percentage by volume of carbon monoxide observed;
- F is the volumetric flow rate, in millilitres per second;
- R is the vapour phase sampling time, in seconds;
- S is the number of cigarettes smoked during the CO sampling period;
- p is the ambient pressure, in kilopascals;
- t is the ambient temperature, in degrees centigrade;
- p_0 is the standard atmospheric pressure (101,325 kPa);
- T_0 is the temperature for the critical point of water, in Kelvin (273 K).

This yield, in millilitres per cigarette, can be converted to milligrams per cigarette by applying Formula (4):

$$m_{\text{cig}} = V_{\text{as}} \times M_{\text{CO}} / V_{\text{m}} \quad (4)$$

where

- m_{cig} is the average mass of carbon monoxide per cigarette, in milligrams;
- M_{CO} is the molar mass of carbon monoxide, in grams per mole (28);
- V_{m} is the molar volume of an ideal gas, in litres per mole (22,4).

NOTE The carbon dioxide if measured is calculated in the same way except the M_{CO_2} for carbon dioxide is 44.

11 Summary of other test sample calculations

The number of puffs per cigarette, P , is given by Formula (5):

$$P = P_{\text{T}} / q \quad (5)$$

where

- P_{T} is total number of puffs per port;
- q is the number of cigarettes smoked per port.

The mainstream smoke pad TPM, m_{TPM} , expressed in milligrams per cigarette, is given by Formula (6):

$$m_{\text{TPM}} = \frac{m_2 - m_1}{q} \quad (6)$$

where

m_2 is the mass of the mainstream smoke trap after smoking, in milligrams;

m_1 is the mass of the mainstream smoke trap before smoking, in milligrams;

q is the number of cigarettes smoked into the trap.

The sidestream smoke pad TPM, s_{TPM} , expressed in milligrams per cigarette, is given by Formula (7):

$$s_{\text{TPM}} = \frac{m_4 - m_3}{q} \quad (7)$$

where

m_4 is the mass of the sidestream smoke trap after smoking, in milligrams;

m_3 is the mass of the sidestream smoke trap before smoking, in milligrams;

q is the number of cigarettes smoked into the trap.

NOTE These data should be recorded and monitored as a check on smoking conditions, but will not form part of the statistical analysis.

12 Test report

12.1 General

The test report shall show the method used and the results obtained. It shall also mention any operating conditions not specified in this International Standard, or regarded as optional, as well as any circumstances that may have influenced the results.

The test report shall include all details required for complete identification of the sample. Where appropriate, record the information in [12.2](#) to [12.5](#).

12.2 Characteristic data about the cigarette

All details necessary for the identification of the cigarette smoked shall be given. In the case of a commercial cigarette this may include:

- name of manufacturer, country of manufacture;
- product name;
- packet number (of that product sampled that day);
- marks on any tax stamp;
- printed mainstream smoke yields (if any);
- length of cigarette;
- length of filter;

- length of overwrap.

12.3 Data about sampling

The following particulars shall be included:

- date of sampling;
- place of purchase or sampling;
- kind of sampling point;
- sampling point (e.g. address of retail outlet or machine number);
- type of sampling procedure;
- number of cigarettes in laboratory sample;
- date and location of purchase.

12.4 Description of test

The following particulars shall be included:

- date of test;
- type of smoking machine used;
- type of smoke trap used;
- total number of cigarettes smoked in the entire determination on that cigarette type;
- number of cigarettes smoked into each smoke trap;
- butt length;
- room temperature (in degrees centigrade) during smoking operation;
- relative humidity (in percent) during smoking operation;
- atmospheric pressure (in kilopascals) during smoking operation;
- reference to this International Standard.

12.5 Test results

The expression of the laboratory data depends on the purpose for which the data are required, and the level of laboratory precision.

- average length of the cigarettes, to the nearest 0,1 mm;
- average length of the filter, to the nearest 0,1 mm;
- average length of the overwrap, to the nearest 0,1 mm;
- butt length to which cigarettes were smoked, to the nearest 0,1 mm;
- average lengths of tobacco portion smoked, to the nearest 0,1 mm;
- average diameter of the cigarettes, in millimetres;
- average draw resistance of the conditioned cigarettes;
- average mass, in milligrams per cigarette, of the conditioned test portion;

- water content, as a mass fraction in percent, of the conditioned cigarettes (see ISO 6488);
- average number of puffs per cigarette for each channel, to the nearest 0,1 puff;
- carbon monoxide sidestream smoke delivery, in milligrams per cigarette, for each channel, to the nearest 0,1 mg and the average per cigarette, to the nearest 1 mg.

13 Repeatability and reproducibility

A major international collaborative study^[2] involving 14 laboratories and seven cigarette samples including the CM3 monitor test piece and spanning a wide range of blends and construction was conducted in 2002 and gave the following values for repeatability, r , and reproducibility, R , of this method.

The difference between two single results found on matched cigarette samples by one operator using the same apparatus within the shortest feasible time interval will exceed the repeatability value, r , on average not more than once in 20 cases in the normal and correct operation of the method.

Single results on matched cigarette samples reported by two laboratories will differ by more than the reproducibility, R , on average not more than once in 20 cases in the normal and correct operation of the method.

Data analysis for the seven cigarettes gave the estimates as summarized in [Table 2](#).

Table 2 — Estimates given by data analysis

Values in milligrams per cigarette

Cigarette sample	CO		
	Mean value m_{CO}	Repeatability limit r	Reproducibility limit R
A	53,96	7,06	14,27
B	60,50	7,45	14,94
C	55,93	6,92	13,46
D	58,66	6,18	11,70
E	50,87	5,63	9,39
F	50,17	5,71	10,55
CM3	58,51	6,40	12,57

For the purposes of calculating r and R , one test result was defined as the mean yield obtained from smoking three cigarettes in a single run. Eight test results were obtained for each cigarette sample type by each of the participating laboratories.

A further international collaborative study involving 12 laboratories and the CORESTA monitor test piece CM6 was conducted in 2008. The technical report^[3] provides further insight of the results.

Annex A (informative)

Smoking plans

A.1 General

In the majority of cases the results of mechanical smoking permit a comparison of types of cigarette (treatment). This comparison should be made according to a smoking plan established in advance. The smoking plan should take account of:

- a) the capacity and the variability of the smoking machine: number of channels;
- b) the capacity of the sidestream smoke collection system: it determines the number of cigarettes to be smoked in each channel;
- c) required precision: the results of smoking always give a certain variability; the distributions of the treatments in each smoking run and of the smoking runs in time should reduce the effects of uncontrolled or badly controlled factors (mechanical or personal); in general the larger the test portion, the greater the precision.

The order of magnitude of the number N of cigarettes in a test portion is fixed for each type as a function of various factors in particular:

- the precision sought;
- the time necessary for the smoking processes, itself related to the capacity of the machine.

The exact value to be selected for N , chosen in the ranges above (see 7.3) taking into account the preceding factors, is determined by calculation for each experiment taking into account the parameters which characterize that value.

Also if

- t denotes the number of types to be compared (treatments);
- s denotes the number of smoking runs to be carried out;
- c denotes the number of channels on the machine;
- q denotes the number of cigarettes smoked into the same sidestream smoke collection system;

then the different parameters are related by Formula (A.1):

$$t \times N = s \times c \times q \tag{A.1}$$

The examples of smoking plans proposed below illustrate the preceding remarks. They could correspond to the following objectives.

- Example 1: comparison of two types of cigarette on one single-channel smoking machine. The sidestream smoke collection system can collect the sidestream smoke condensate of three cigarettes.
- Example 2: comparison of three types of cigarette on one single-channel smoking machine. The sidestream smoke collection system can collect the sidestream smoke condensate of three cigarettes.
- Example 3: comparison of two types of cigarette on one four-channel smoking machine. The sidestream smoke collection system can collect the sidestream smoke condensate of three cigarettes.

- Example 4: comparison of five types of cigarette on one 20-channel smoking machine. The sidestream smoke collection system can collect the sidestream smoke condensate of three cigarettes.

A.2 Examples

A.2.1 EXAMPLE 1 Comparison of two types of cigarette on one single-channel smoking machine

Number of treatments	$t = 2$ (A, B)
Number of cigarettes in the test sample	$N = 24$
Number of cigarettes per channel	$q = 3$
Number of channels	$c = 1$
Number of smoking runs	$s = 16$ (1, 2, ... 16)
Thus testing 48 cigarettes	$2 \times 24 = 16 \times 1 \times 3$

The number N of cigarettes to be smoked is limited to 24 of each type, so that the duration of the smoking process is not too long. Each smoking run carries only one treatment. Distribute the runs in time while repeating the sequence given in [Table A.1](#) four times (k represents successive values 0, 4, 8 and 12):

Table A.1

Runs	Treatment
$1 + k$	A
$2 + k$	B
$3 + k$	B
$4 + k$	A

A.2.2 EXAMPLE 2 Comparison of three types of cigarette on one single-channel smoking machine

Number of treatments	$t = 3$ (A, B, C)
Number of cigarettes in the test sample	$N = 24$
Number of cigarettes per channel	$q = 3$
Number of channels	$c = 1$
Number of smoking runs	$s = 24$ (1, 2, ... 24)
Thus testing 72 cigarettes	$3 \times 24 = 24 \times 1 \times 3$

Each smoking run carries only one treatment. The runs are distributed in time in an ordered fashion, e.g. by means of a matrix of the following type:

B	A	C
C	B	A
A	C	B

A.2.3 EXAMPLE 3 Comparison of two types of cigarette on one four-channel smoking machine

Number of treatments	$t = 2$ (A, B)
Number of cigarettes in the test sample	$N = 24$
Number of cigarettes per channel	$q = 3$
Number of channels	$c = 4$ (a, b, c, d)
Number of smoking runs	$s = 4$ (1, 2, 3, 4)
Thus testing 48 cigarettes	$2 \times 24 = 4 \times 4 \times 3$

Allocate the smoking channels in the two treatments utilizing the matrix below, which is constructed for four treatments but which is easily adapted to the case of two treatments by identifying A with C on the one hand and B with D on the other. (In general all matrices of dimension g can be utilized for a number of treatments which are sub-multiples of g .)

A	B	C	D
D	C	A	B
B	A	D	C
C	D	B	A

Run	Channel			
	a	b	c	d
1	A	B	A	B
2	B	A	A	B
3	B	A	B	A
4	A	B	B	A

In each smoking run, two channels are allocated to each treatment. For example, in run 2:

- cigarette A is smoked in channels b and c,
- cigarette B is smoked in channels a and d.

Each type is smoked twice in each of the four channels.

A.2.4 EXAMPLE 4 Comparison of five types of cigarette on one 20-channel smoking machine

Number of treatments	$t = 5$ (A, B, C, D, E)
Number of cigarettes in the test sample	$N = 24$
Number of cigarettes per channel	$q = 3$
Number of channels	$c = 20$ (a, b, ... t)
Number of smoking runs	$s = 2$ (1, 2)
Thus testing 120 cigarettes	$5 \times 24 = 2 \times 20 \times 3$

Allocate the smoking channels to five treatments using the matrix below:

D B E A C
 A D B C E
 B A C E D
 C E D B A
 E C A D B

Run	Channel																			
	a	b	c	d	e	f	g	h	i	j	k	l	m	n	o	p	q	r	s	t
1	D	B	E	A	C	C	E	D	A	B	E	C	B	A	D	B	D	A	C	E
2	A	D	B	C	E	A	C	E	B	D	C	E	A	D	B	A	B	D	E	C

In each smoking run each treatment is smoked in four channels. For example in run 1:

- cigarette A is smoked in the channels d, i, n, r,
- cigarette B is smoked in the channels b, j, m, p,
- cigarette C is smoked in the channels e, f, l, s,
- cigarette D is smoked in the channels a, h, o, q,
- cigarette E is smoked in the channels c, g, k, t.

Thus each treatment is smoked in eight different channels.

Annex B (informative)

Alternative procedure for CO calibration

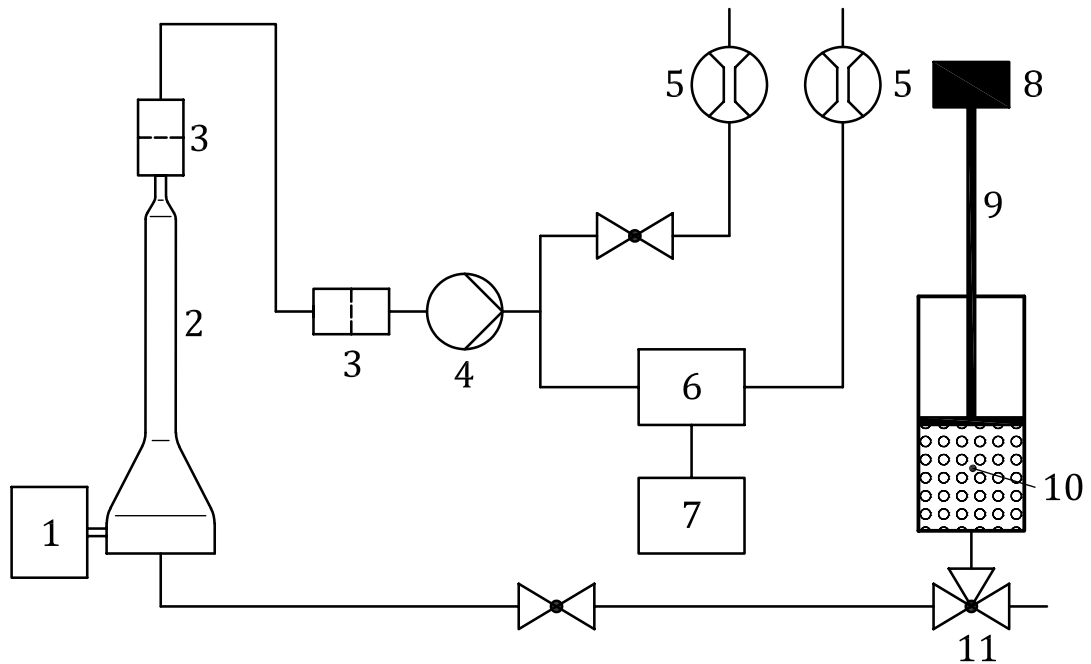

Key

- 1 smoking machine
- 2 fishtail
- 3 Cambridge filter
- 4 pump
- 5 rotameter
- 6 CO detector
- 7 integrator
- 8 heavy weight
- 9 syringe, 2 000 ml
- 10 calibration gas mixture carbon monoxide in nitrogen
- 11 3-way valve manually actuated

Figure B.1 — Set-up for alternative procedure for CO calibration

Bibliography

- [1] ISO 8243, *Cigarettes — Sampling*
- [2] Task Force on Sidestream Smoke – Review of Activities. CORESTA (2001 – 2002)
- [3] CORESTA Technical Report, 2008 Collaborative study of the CORESTA monitor test piece CM 6 for the determination of nicotine, NFDPM, carbon monoxide and carbon dioxide in sidestream smoke; August 2010

British Standards Institution (BSI)

BSI is the national body responsible for preparing British Standards and other standards-related publications, information and services.

BSI is incorporated by Royal Charter. British Standards and other standardization products are published by BSI Standards Limited.

About us

We bring together business, industry, government, consumers, innovators and others to shape their combined experience and expertise into standards-based solutions.

The knowledge embodied in our standards has been carefully assembled in a dependable format and refined through our open consultation process. Organizations of all sizes and across all sectors choose standards to help them achieve their goals.

Information on standards

We can provide you with the knowledge that your organization needs to succeed. Find out more about British Standards by visiting our website at bsigroup.com/standards or contacting our Customer Services team or Knowledge Centre.

Buying standards

You can buy and download PDF versions of BSI publications, including British and adopted European and international standards, through our website at bsigroup.com/shop, where hard copies can also be purchased.

If you need international and foreign standards from other Standards Development Organizations, hard copies can be ordered from our Customer Services team.

Subscriptions

Our range of subscription services are designed to make using standards easier for you. For further information on our subscription products go to bsigroup.com/subscriptions.

With **British Standards Online (BSOL)** you'll have instant access to over 55,000 British and adopted European and international standards from your desktop. It's available 24/7 and is refreshed daily so you'll always be up to date.

You can keep in touch with standards developments and receive substantial discounts on the purchase price of standards, both in single copy and subscription format, by becoming a **BSI Subscribing Member**.

PLUS is an updating service exclusive to BSI Subscribing Members. You will automatically receive the latest hard copy of your standards when they're revised or replaced.

To find out more about becoming a BSI Subscribing Member and the benefits of membership, please visit bsigroup.com/shop.

With a **Multi-User Network Licence (MUNL)** you are able to host standards publications on your intranet. Licences can cover as few or as many users as you wish. With updates supplied as soon as they're available, you can be sure your documentation is current. For further information, email bsmusales@bsigroup.com.

BSI Group Headquarters

389 Chiswick High Road London W4 4AL UK

Revisions

Our British Standards and other publications are updated by amendment or revision.

We continually improve the quality of our products and services to benefit your business. If you find an inaccuracy or ambiguity within a British Standard or other BSI publication please inform the Knowledge Centre.

Copyright

All the data, software and documentation set out in all British Standards and other BSI publications are the property of and copyrighted by BSI, or some person or entity that owns copyright in the information used (such as the international standardization bodies) and has formally licensed such information to BSI for commercial publication and use. Except as permitted under the Copyright, Designs and Patents Act 1988 no extract may be reproduced, stored in a retrieval system or transmitted in any form or by any means – electronic, photocopying, recording or otherwise – without prior written permission from BSI. Details and advice can be obtained from the Copyright & Licensing Department.

Useful Contacts:

Customer Services

Tel: +44 845 086 9001

Email (orders): orders@bsigroup.com

Email (enquiries): cservices@bsigroup.com

Subscriptions

Tel: +44 845 086 9001

Email: subscriptions@bsigroup.com

Knowledge Centre

Tel: +44 20 8996 7004

Email: knowledgecentre@bsigroup.com

Copyright & Licensing

Tel: +44 20 8996 7070

Email: copyright@bsigroup.com



...making excellence a habit.™