

BS ISO 20176:2011



BSI Standards Publication

# Road vehicles — H-point machine (HPM-II) — Specifications and procedure for H-point determination

NO COPYING WITHOUT BSI PERMISSION EXCEPT AS PERMITTED BY COPYRIGHT LAW

*raising standards worldwide™*



**National foreword**

This British Standard is the UK implementation of ISO 20176:2011. It supersedes BS ISO 20176:2006, which is withdrawn. BS ISO 20176 and BS ISO 6549:1999 will co-exist for a transition period of at least ten years.

The UK participation in its preparation was entrusted to Technical Committee AUE/12, Safety related to occupants.

A list of organizations represented on this committee can be obtained on request to its secretary.

This publication does not purport to include all the necessary provisions of a contract. Users are responsible for its correct application.

© BSI 2011

ISBN 978 0 580 69151 5

ICS 43.020; 43.040.60

**Compliance with a British Standard cannot confer immunity from legal obligations.**

This British Standard was published under the authority of the Standards Policy and Strategy Committee on 30 June 2011.

**Amendments issued since publication**

Date	Text affected
------	---------------

---

---

---

**Road vehicles — H-point machine  
(HPM-II) — Specifications and procedure  
for H-point determination**

*Véhicules routiers — Machine point H (HPM-II) — Spécifications et  
procédure pour la détermination du point H*



**PDF disclaimer**

This PDF file may contain embedded typefaces. In accordance with Adobe's licensing policy, this file may be printed or viewed but shall not be edited unless the typefaces which are embedded are licensed to and installed on the computer performing the editing. In downloading this file, parties accept therein the responsibility of not infringing Adobe's licensing policy. The ISO Central Secretariat accepts no liability in this area.

Adobe is a trademark of Adobe Systems Incorporated.

Details of the software products used to create this PDF file can be found in the General Info relative to the file; the PDF-creation parameters were optimized for printing. Every care has been taken to ensure that the file is suitable for use by ISO member bodies. In the unlikely event that a problem relating to it is found, please inform the Central Secretariat at the address given below.



**COPYRIGHT PROTECTED DOCUMENT**

© ISO 2011

All rights reserved. Unless otherwise specified, no part of this publication may be reproduced or utilized in any form or by any means, electronic or mechanical, including photocopying and microfilm, without permission in writing from either ISO at the address below or ISO's member body in the country of the requester.

ISO copyright office  
Case postale 56 • CH-1211 Geneva 20  
Tel. + 41 22 749 01 11  
Fax + 41 22 749 09 47  
E-mail [copyright@iso.org](mailto:copyright@iso.org)  
Web [www.iso.org](http://www.iso.org)

Published in Switzerland

## Contents

Page

Foreword .....	iv
Introduction.....	v
<b>1 Scope .....</b>	<b>1</b>
<b>2 Normative references .....</b>	<b>1</b>
<b>3 Terms and definitions .....</b>	<b>1</b>
<b>4 Measurement procedure for the three-dimensional H-point machine .....</b>	<b>3</b>
4.1 General .....	3
4.2 Summary of installation procedure .....	4
4.3 Prepare vehicle and seat .....	4
4.4 Determine the H-point travel path (optional) .....	5
4.5 Adjust seat to design intent .....	6
4.6 Install HPM cushion and back pan assembly .....	7
4.7 Load the HPM.....	9
4.8 Soak time.....	10
4.9 Record measurements — digitize HPM points.....	11
<b>5 Optional measurements for driver seat .....</b>	<b>12</b>
5.1 Leg and shoe installations .....	12
5.2 Record measurements.....	14
<b>6 Optional measurements for the 2nd or succeeding row passenger seats .....</b>	<b>17</b>
6.1 Leg and shoe installation .....	17
6.2 Record measurements for rear passengers .....	21
<b>7 Additional optional measurements .....</b>	<b>23</b>
7.1 Effective headroom .....	23
<b>8 Remove the HPM .....</b>	<b>24</b>
<b>Annex A (normative) Description of the three-dimensional H-point machine (HPM).....</b>	<b>25</b>
<b>Annex B (informative) HPM specification and tolerances .....</b>	<b>36</b>
<b>Annex C (informative) HPM field checking procedures .....</b>	<b>44</b>
<b>Annex D (informative) H-point design (HPD) tool description .....</b>	<b>60</b>
<b>Bibliography.....</b>	<b>63</b>

## Foreword

ISO (the International Organization for Standardization) is a worldwide federation of national standards bodies (ISO member bodies). The work of preparing International Standards is normally carried out through ISO technical committees. Each member body interested in a subject for which a technical committee has been established has the right to be represented on that committee. International organizations, governmental and non-governmental, in liaison with ISO, also take part in the work. ISO collaborates closely with the International Electrotechnical Commission (IEC) on all matters of electrotechnical standardization.

International Standards are drafted in accordance with the rules given in the ISO/IEC Directives, Part 2.

The main task of technical committees is to prepare International Standards. Draft International Standards adopted by the technical committees are circulated to the member bodies for voting. Publication as an International Standard requires approval by at least 75 % of the member bodies casting a vote.

Attention is drawn to the possibility that some of the elements of this document may be the subject of patent rights. ISO shall not be held responsible for identifying any or all such patent rights.

ISO 20176 was prepared by Technical Committee ISO/TC 22, *Road vehicles*, Subcommittee SC 13, *Ergonomics applicable to road vehicles*.

This second edition of ISO 20176 cancels and replaces the first edition (ISO 20176:2006), which has been technically revised. It also constitutes a technical revision of ISO 6549:1999.

It is the intent of ISO/TC 22/SC 13 that both ISO 20176 and ISO 6549:1999 be applicable until 2021-05-31. ISO 6549:1999 is thus provisionally retained until this date.

As from 2021-06-01, ISO 20176 will cancel and replace ISO 6549:1999.

During the transition period, it is the responsibility of vehicle designers to specify to regulatory and other bodies which document is applicable.

## Introduction

The tools and procedures for H-point determination given in this International Standard are based on SAE J4002.

H-point devices are used during vehicle design and development to establish interior reference points and dimensions for occupant packaging, and to validate the location of these key reference points and dimensions on physical properties during audits.

H-point devices are also used for the design and validation of seats. However, in these instances, the reference points and dimensions are defined relative to the seat structure or surface, rather than the vehicle's interior. The procedures for positioning the H-point devices in seats do not require the use of the shoe tool or leg segments.

For convenience and simplicity, many terms associated with H-point devices use human body parts in their name. However, they should not be construed as measures that indicate occupant accommodation, human capabilities, or comfort. H-point devices do not represent the size or posture of any category of occupant.

### a) Key differences from ISO 6549

Compared to the H-point machine (HPM) specified in ISO 6549, the HPM specified in this International Standard provides improved repeatability, greater ease of use, as well as additional features and measurement capabilities. All efforts were made to achieve these improvements while minimizing their impact on the location of reference points and measurements. Several of the changes are discussed below.

#### 1) Separate components

For this HPM, the legs (upper and lower), shoe, cushion pan and back pan are all separate pieces. This greatly improves the ease of installation.

#### 2) “Legless” manikin

The H-point location is defined without having to attach the legs. This is a major advantage. The procedure specified in this International Standard is based on installing the HPM without legs. Use of legs is optional.

#### 3) Shoe tool

Several improvements were made to the shoe tool and how it is positioned in the vehicle, including:

- i) replacing the pedal reference point (PRP) with a new ball of foot reference point (BOFRP);
- ii) specifying a new procedure for positioning the shoe on the pedal.

#### 4) Cushion angle

The cushion angle is now measured independently of thigh angle, and at the same time the other measurements are made. With the ISO 6549 HPM, cushion angle was measured from the thigh line, and required a separate installation of the HPM.

#### 5) Lumbar support

The articulation of the back pan assembly allows the HPM specified in this International Standard to be better seated in contoured seats. It also provides a measurement of lumbar support prominence (LSP). This measurement provides an indication of the amount the seat back is contoured to provide support for the

lumbar spine. The contour of the back pan assembly is most similar to the ISO 6549 H-point machine when the HPM is in a neutral posture (LSP equals zero).

**b) Changes from ISO 20176:2006**

The procedures for auditing the seat are essentially unchanged from the first edition. The most significant change is that the ball of foot (BOF) of the shoe does not have to be on the pedal surface. The HPM shoe can contact the pedal at any point(s) on the bottom of the shoe. The term pedal reference point (PRP) has been deleted (since the BOF may not be on the pedal) and replaced by a new term called the ball of foot reference point (BOFRP). The accelerator heel point (AHP) to BOF distance was changed from 200 mm to 203 mm to be consistent with ISO 6549, SAE J1100, and vehicle manufacturers around the world.

The following physical modifications were made to the HPM. The flat part of the shoe bottom was extended from 200 mm to 203 mm. A new scale was added to the top of the shoe to aid in determining the pedal contact point (PCP). A new H-point divot was added to allow coordinate measuring machine (CMM) point taking from above. The knee angle scale was recessed to improve its durability and reoriented to improve its readability. Several figures were revised to illustrate these changes.

The terms pedal plane and pedal plane angle (PPA) have been replaced by shoe plane and shoe plane angle (SPA). These new terms more accurately convey the meaning. SPA is a side view angle that is provided by the vehicle manufacturer.



# Road vehicles — H-point machine (HPM-II) — Specifications and procedure for H-point determination

## 1 Scope

This International Standard provides the specifications and procedures for using the H-point machine (HPM)<sup>1)</sup> to audit vehicle seating positions. The HPM is a physical tool used to establish key reference points and measurements in a vehicle. The H-point design tool (HPD) is a simplified computer-aided design (CAD)<sup>2)</sup> version of the HPM, which can be used in conjunction with the HPM to take the optional measurements specified in this International Standard, or used independently during product design.

These H-point devices provide a method for reliable layout and measurement of occupant seating compartments or seats. This International Standard specifies the procedures for installing the H-point machine (HPM) and using the HPM to audit (verify) key reference points and measurements in a vehicle.

The devices are intended for application at designated seating positions. They are not to be construed as tools that measure or indicate occupant capabilities or comfort. They are not intended for use in defining or assessing temporary seating, such as folding jump seats.

## 2 Normative references

The following referenced documents are indispensable for the application of this document. For dated references, only the edition cited applies. For undated references, the latest edition of the referenced document (including any amendments) applies.

ISO 4130, *Road vehicles — Three-dimensional reference system and fiducial marks — Definitions*

SAE J1100, *Motor vehicle dimensions*

SAE J4002, *H-point machine (HPM-II) specifications and procedure for H-point determination — Auditing vehicle seats*

## 3 Terms and definitions

For the purposes of this document, the terms and definitions given in SAE J1100 and the following apply.

### 3.1

#### **H-point**

point at the pivot centre of the back pan and cushion pan assemblies, located on the lateral centreline of the H-point device

---

1) All references to H-point machine or HPM in this International Standard refer to the SAE J4002 H-point machine (HPM-II), unless otherwise noted.

2) CAD has come to encompass any software system or approach to automotive design and development, and is often used to refer to CAE (computer-assisted engineering) and CAM (computer-assisted manufacturing) software systems as well.

NOTE 1 The H-point device can be the H-point machine (HPM) or the H-point design tool (HPD).

NOTE 2 The H-point is also the intersection of the cushion line and the torso line. When an H-point device is properly positioned within a vehicle, either in CAD or in an actual physical property, the location of the H-point relative to the vehicle is used as a vehicle reference point. If the seat is moved, the location of the H-point within the vehicle is changed. Therefore, adjustable seats have more than one H-point location, while fixed seats have only one H-point location.

NOTE 3 H-points are often referred to as hip points or hip pivot points. They simulate, but do not precisely represent, the location of the human hip joint.

### 3.2 H-point travel path

all possible locations of the H-point provided by the full range of seat adjustments (horizontal, vertical or tilt) for a given designated seating position

### 3.3 seating reference point SgRP R-point

manufacturer's intended location for a design H-point, which is specifically designated as R-point or SgRP, and which:

- a) is the fundamental reference point used to establish occupant accommodation tools and dimensions;
- b) simulates the position of the pivot centre of the human torso and thigh;
- c) has coordinates established with respect to the designed vehicle structure;
- d) establishes the rearmost normal design driving or riding H-point of each designated seating position, which accounts for all modes of adjustment, horizontal, vertical and tilt that are available for the seat, but does not include seat travel used for purposes other than normal driving and riding

NOTE The SgRP is sometimes referred to as the design H-point.

### 3.4 accelerator heel point AHP

point representing the heel of shoe location on the depressed floor covering, when the bottom of shoe is in contact with the undepressed accelerator pedal and the ankle angle is at 87°

NOTE The lateral location (*y*-coordinate) is aligned with the BOFRP unless shoe interference with side support structure causes an offset of the AHP from the BOFRP (see 5.1.4.2).

### 3.5 ball of foot reference point BOFRP

point representing the ball of foot location on the shoe plane when the H-point machine shoe is set to a specified shoe plane angle, the bottom of shoe is in contact with the undepressed accelerator pedal, the ball of foot is aligned with the lateral centreline of the undepressed accelerator pedal in rear view, and the heel of shoe is at the depressed floor covering

NOTE The BOFRP and AHP are at the same *y*-coordinate unless there is lateral shoe interference.

### 3.6 floor reference point, rear passenger FRP

point at the intersection of the heel of shoe and the depressed floor covering, with the bottom of shoe resting on the depressed floor covering

NOTE FRP is determined within 127 mm to either side of centreline of occupant, with the shoe or lower leg segment moved forward to rest against the seat in front (contacting the underseat structure, lower portion of the seat back trim, etc.).

### 3.7

#### lumbar support prominence

##### LSP

measure of the back pan shape imposed on the HPM by the contour of the lower seatback

See Table A.4.

### 3.8

#### shoe plane angle

##### SPA

$\alpha_{SP}$

angle from horizontal to the bottom of the HPM shoe when the shoe is in contact with the undepressed accelerator pedal and the shoe heel is at the AHP

NOTE SPA is provided by the vehicle manufacturer or calculated from the manufacturer's published seat height H30-1 (see 5.1.4).

## 4 Measurement procedure for the three-dimensional H-point machine

### 4.1 General

A complete description of the three-dimensional H-point machine is given in Annex A (see Figure 1). Specifications and tolerances are given in Annex B. A field checking procedure for the HPM is given in Annex C.

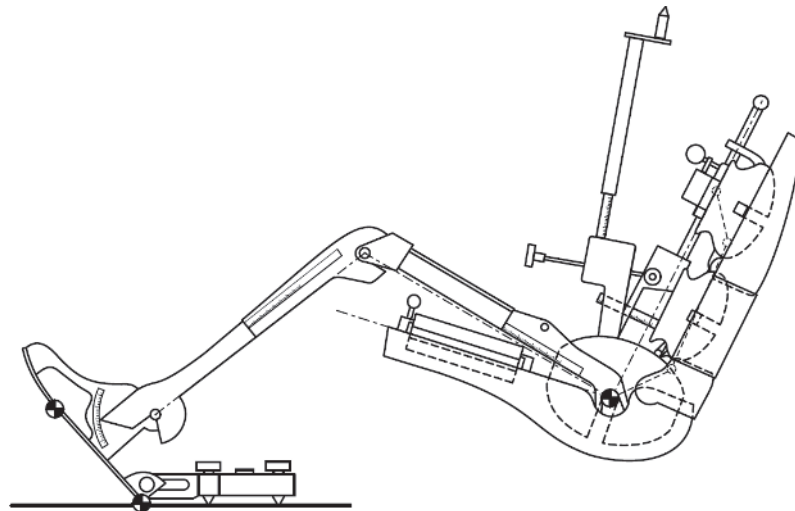

Figure 1 — Side view of HPM, including optional components

The HPM includes divot points that can be used by a coordinate measuring machine (CMM) and in CAD to fully define the location of the machine in the vehicle space (see A.2.3). Calibrated planar surfaces on the HPM facilitate field measurement of machine angles using an inclinometer. A scale readout indicates the lumbar support prominence (LSP) value. An ankle angle scale is provided to aid HPM installation in long-coupled passenger seating.

Several of the reference points established with an H-point device are required for the subsequent positioning of other design devices, such as head contours, eyellipses, and reach curves. The most important reference points established by an H-point device are the H-point, the H-point travel path, the seating reference point (SgRP), the accelerator heel point (AHP), and the ball of foot reference point (BOFRP). These reference points are illustrated in Figure A.8.

## 4.2 Summary of installation procedure

### 4.2.1 Summary

See Table 1.

**Table 1 — Summary of installation procedure**

Driver position	Passenger positions: 2nd and 3rd row
Prepare the physical property. If possible, calibrate the CMM equipment to vehicle grid coordinates	
Position seat to design intent location and attitude	Position the test seat and (if the HPM legs are to be installed) the seat in front of the test seat to design intent location and attitude
Install shoe fixture and shoe tool, if measuring leg and shoe dimensions. Record shoe-based measurements. See 5.1	Install shoe tool, if measuring leg and shoe dimensions. Record shoe-based measurements. See 6.1
Install and load the cushion pan, and back pan. If measuring headroom, install headroom fixture before loading the pans. See 7.1. Determine H-point, torso angle, cushion angle, and LSP. See 4.8	
Attach thigh and lower leg segments, if measuring leg-based dimensions. See 5.1	Attach thigh and lower leg segments, if measuring leg-based dimensions. See 6.1
Determine optional measurements. See 5.2 and 7.1	Determine optional measurements. See 6.2 and 7.1

### 4.2.2 Measured versus design values

When verifying or auditing a particular designated vehicle seating position, measurements taken with the three-dimensional HPM are normally compared to the design values indicated by the vehicle manufacturer. If any measured value is sufficiently close to the manufacturer's design value, the vehicle or seat is considered to meet the manufacturer's design intent for that measurement. The vehicle manufacturer or a regulatory agency may provide specifications for the term "sufficiently close". Two HPM measurements of particular interest are H-point (SgRP) and torso angle.

## 4.3 Prepare vehicle and seat

### 4.3.1 Vehicle

Dimensions shall be measured relative to the vehicle three-dimensional reference system by setting up the vehicle relative to the fiducial marks in accordance with ISO 4130 as specified by the manufacturer. The vehicle (or seating buck) shall be levelled prior to any HPM installation or measurement. Once the vehicle is levelled, care should be taken to not lean on it, rock it, or in some other way knock it off level.

If the accelerator pedal is needed for the measurements, the accelerator pedal shall be held in an undepressed position by some means. For example, use blocks or clamp the accelerator cable to prevent the pedal from moving. If the pedal rotates about a pivot, independent of throttle movement, do not restrict that motion. If the accelerator pedal has fore/aft adjustment, the pedal shall be positioned as specified by the manufacturer. If no specification is provided, the pedal shall be adjusted to its most forward position in the vehicle.

### 4.3.2 Seat

The vehicle shall be preconditioned at the manufacturer's discretion, at a temperature of 19 °C to 26 °C to ensure that the seat material reaches room temperature. Room relative humidity should be within 50 % ± 5 %. If this relative humidity is not met, record both relative humidity and room temperature

The following considerations are to help ensure that stable, reliable measurements are made across seat types. If the seat to be checked has never been sat upon, a 70 kg to 80 kg person or device shall be placed on the seat to flex the cushion and back. Prior to the installation of the HPM, seats should remain unloaded for 30 min at the manufacturer's request. This is to allow the seat and seat materials (e.g. foam) to recover from compression.

Muslin cloth should be placed over the seat prior to installing the HPM. The muslin cloth may be a single piece fitting across both seat cushion and seat back, or two pieces, one for the cushion and one for the seat back. This ensures a constant friction surface across seat fabrics. See B.11.

When using the HPM, interactions can occur between adjacent seating positions (i.e. having an HPM installed at the centre occupant position can change the results obtained for the outboard occupant position). Therefore, only one machine should be installed in a particular row of seats during each test.

#### 4.4 Determine the H-point travel path (optional)

If verification of the H-point travel path is desired, the seat's travel path shall be digitized and then translated to the H-point travel path. First, adjust the seat cushion to the middle of the cushion angle adjustment range. Next, place one or more registration marks on the side of the seat. The registration mark(s) can be located anywhere along the side of the seat that can be easily accessed by the CMM equipment. Finally, digitize the location of the registration mark(s) with the seat in each of four positions: lowest most-rearward, highest most-rearward, highest most-forward, lowest most-forward. By connecting these four points, the seat's travel path can be seen more readily. See Figure 2 a) and b).

NOTE For seats without vertical adjustment, only two points need to be taken, most forward and most rearward, provided the seat track follows a linear path. If the seat track travel path is curved, additional points (between foremost and rearmost) need to be taken.

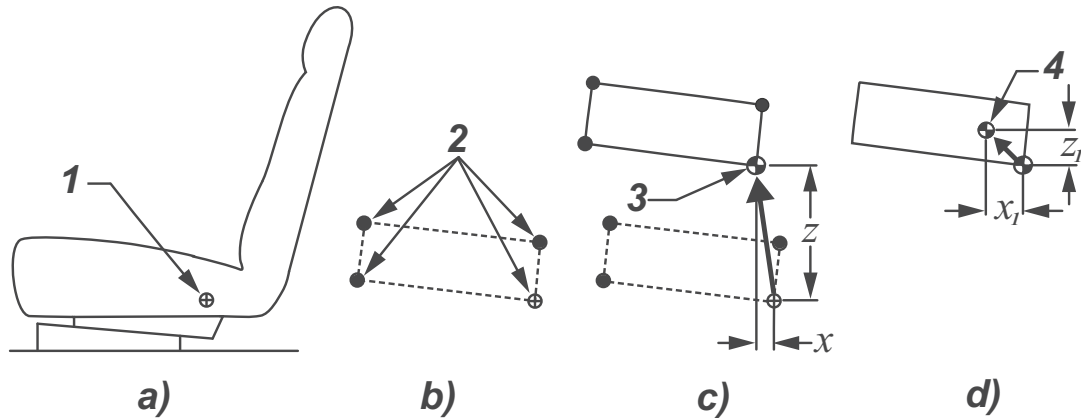

a) Place registration mark on seat with seat at lowest most-rearward position

b) Move seat through its fore/aft and up/down travel path

c) Translate seat travel path by  $(x, z)$  to get the H-point travel path

d) Move seat by  $(x_1, z_1)$  from lowest, most-rearward H-point to its SgRP location

#### Key

- 1 registration mark
- 2 registration mark at extremes of seat travel
- 3 lowest, most-rearward H-point
- 4 SgRP

Figure 2 — Locating seating reference point from the seat travel path

## 4.5 Adjust seat to design intent

### 4.5.1 Move seat to design intent position

All adjustable features of the seat shall be set to manufacturer's design intent attitude or position before installing the HPM.

For seats with an independent vertical adjustment or suspension, the vertical position shall be rigidly fixed in a position specified by the manufacturer.

The seat registration mark is helpful in positioning the seat at design intent relative to one of the seat's extreme locations (usually the rearmost, lowest position) determined in 4.4. Normally, the design intent position specified by the vehicle manufacturer is the SgRP. Figure 2 illustrates a typical way to translate seat travel to H-point travel, and then to SgRP. After an adjustable seat is positioned at design intent, digitize the seat registration mark(s).

### 4.5.2 Torso angle and cushion angle

#### 4.5.2.1 General

Seat torso and cushion angle adjustment procedures for auditing differ depending on whether or not variance in seat build is of interest.

#### 4.5.2.2 Standard audit: include seat and vehicle build variability

The seat shall be adjusted to the design intent torso angle and cushion angle before installing the HPM. The vehicle manufacturer (or seat supplier) shall provide information regarding the location and attitude of the discernable seat structure (e.g. the seat frame), other hard points (e.g. seat controls, pivot points, head restraint rods), or the amount of adjustment required to attain the desired seat attitude.

#### 4.5.2.3 Optional audit: exclude seat build variability

If the purpose of the audit is to evaluate the build of the vehicle package without accounting for seat build variability, then the HPM needs to be installed in order to set the seat to the design intent values of torso and cushion angles.

As the HPM is loaded with weights, torso angle tends to increase and cushion angle tends to decrease. If torso and cushion angles are adjustable, the initial (unloaded) angles usually differ by about 1° to 2° from the desired final angles after loading. For example, set the seat back initially to an angle of approximately 20° to achieve a final torso angle of 22°.

Monitor and readjust torso and cushion angles as necessary during installation of HPM weights in order to achieve the design intent angles as the final reading (see Table 2). Then, remove the HPM, wait 30 min to allow the seat materials to recover, and install the HPM a second time for the audit. For this audit, the HPM installation normally includes the leg and shoe tool, as well as the headroom fixture.

NOTE The seat can also be audited independently of the vehicle.

**Table 2 — Optional audit: Adjusting torso and cushion angles during HPM loading**

Angle	Driver position	Passenger positions: 2nd or 3rd row
<b>Torso angle A40</b>	Initially set the torso angle to approximately 2° more vertical than design intent. Monitor and adjust if needed during HPM loading to achieve design intent	If the seat recliner is adjustable, initially set the torso angle to approximately 2° more vertical than design intent. Monitor and adjust if needed during HPM loading to achieve design intent
<b>Cushion angle A27</b>	If the seat cushion is adjustable, initially set the cushion angle to be slightly greater than design intent value. Monitor and readjust as necessary during HPM installation to achieve the design intent cushion angle as the final reading	

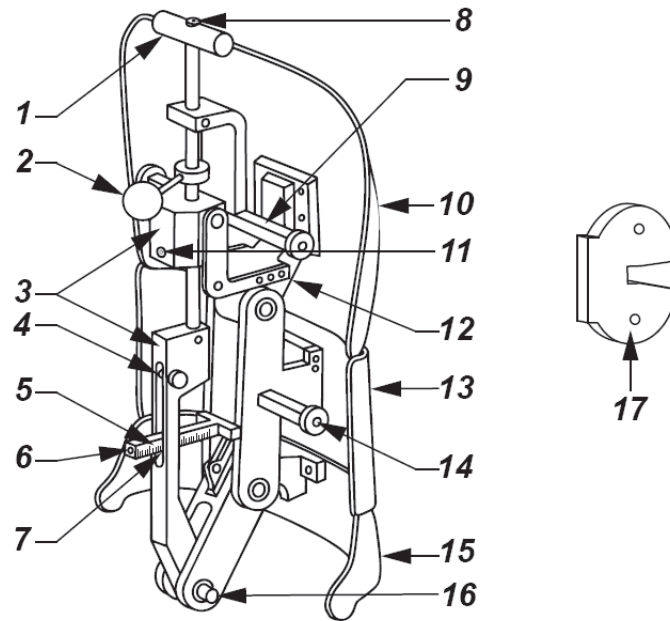

**Key**

- |   |                                  |
|---|----------------------------------|
| 1 handle                                | 10 thoracic segment              |
| 2 torso articulation locking lever      | 11 B2 divot                      |
| 3 inclinometer lands for torso angle    | 12 articulation mechanism        |
| 4 head room fixture tumbler             | 13 lumbar segment                |
| 5 lumbar support prominence (LSP) scale | 14 lower weight rack (left side) |
| 6 load application point                | 15 pelvic segment                |
| 7 indicator to read LSP value           | 16 H-point pivot shaft           |
| 8 B1 divot                              | 17 one of twelve back weights    |
| 9 upper weight rack (left side)         |                                  |

**Figure 3 — Back pan**

**4.5.3 Seat in front of test seat**

If leg positions, legroom, footroom, and knee clearance are to be measured, the seat in front of the test seat should be positioned to its SgRP and design intent torso angle.

**4.6 Install HPM cushion and back pan assembly**

**4.6.1 Install the cushion pan**

Place the cushion pan (see Figure 4) on the seat with the back of the pan resting lightly against the seat back. Visually centre the cushion pan laterally in the seat.

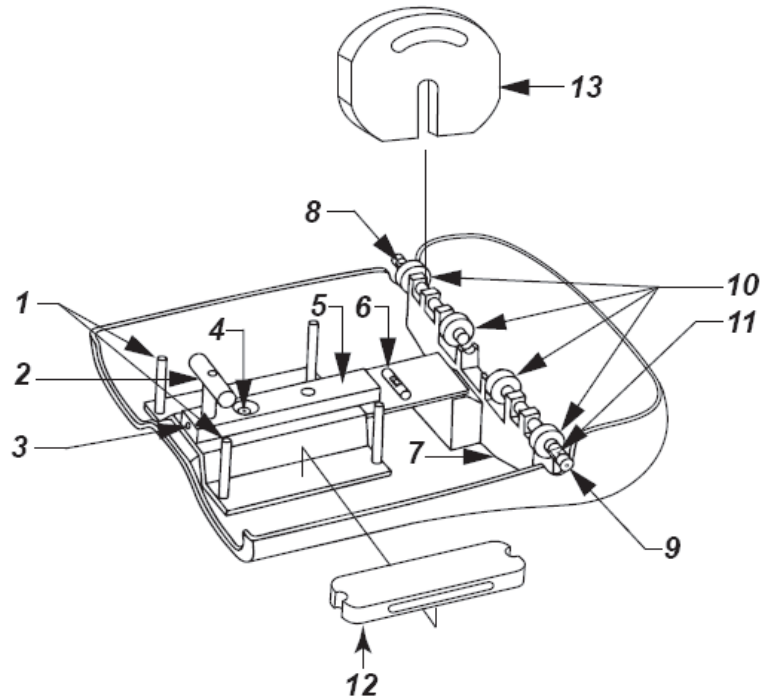

**Key**

- 1 thigh weight locating pins (4)
- 2 handle
- 3 load application point
- 4 C1 divot
- 5 inclinometer land for cushion angle
- 6 lateral level
- 7 H-point saddle
- 8 H1R divot
- 9 H1L divot
- 10 locking bushings for attaching back pan (2), thigh segment (2) and headroom fixture
- 11 H2L divot
- 12 thigh weight (6)
- 13 pelvic weight (6)

**Figure 4 — Cushion pan**

**4.6.2 Install the back pan**

To protect the shells of the cushion and back pans, the back pan should be locked in a slouched position before installing it. Articulate the back pan into a slouched position ( $LSP < 0$ ) and lock.

Place the H-point pivot shaft, located at the base of the back pan, on the H-point saddle of the cushion pan (see Figures 3 and 4). The upper portions of the back pan should not contact the seat back. Secure by sliding the brass locking bushings inwards over the H-point shaft.

Unlock the torso articulation. Put one hand firmly on the cushion pan T-handle to maintain the position of the cushion pan. Put the other hand on the back pan T-handle and gently rotate the back pan assembly against the seat back to allow the back pan assembly to conform to the seat back contour. Ensure that the top and bottom corners at each side of the lumbar segment remain outside the thoracic and pelvic segments. Also ensure that the muslin cloth is not caught between the back segments (see Figure 5).



The cushion and back pan can be connected and installed as a single unit if preferred. Follow the same steps as above, centring the cushion pan lightly against the seat back with the back pan rotated forward and locked in the slouched position.

If measuring headroom, install the headroom fixture now (see 7.1).

#### 4.6.3 Level the HPM

Referring to the bubble level on the cushion pan, dither and adjust the HPM so it is level laterally on the seat. Make sure the HPM is in firm contact with the seat back.

### 4.7 Load the HPM

#### 4.7.1 Procedure

Installing weights on the HPM is referred to as 'loading'. The HPM shall be loaded with the torso articulation mechanism unlocked. Weights shall be installed from the H-point outward and from the H-point upward to prevent the HPM from toppling out of the seat. Prior to each round of weights being loaded, an 89 N force shall be applied twice by 'punching' the appropriate load application site with the spring-loaded probe. The operator shall immediately release any applied force once the punch probe reaches its spring loading. This procedure ensures the HPM remains fully nested into the seat during the loading.

#### 4.7.2 Summary table

The HPM shall be checked for level during the loading process. The sequence of actions for loading the HPM, summarized in Table 3, shall be followed.

**Table 3 — Loading the HPM**

Round	Apply 89 N	Load two weights	Then load two weights	Check for:
1	Punch twice (cushion)	2 Pelvic — innermost positions	2 Thigh	Level
2	Punch twice (cushion)	2 Pelvic — next innermost positions	2 Thigh	Level
3	Punch twice (cushion)	2 bevelled Pelvic — outermost positions	2 Thigh	Level
4	Punch twice (back)	2 Lower rack — innermost positions	2 Upper rack — innermost positions	Level
5	Punch twice (back)	2 Lower rack — next innermost position	2 Upper rack — next innermost positions	Level
6	Punch twice (back)	2 Lower rack — outermost positions	2 Upper rack — outermost positions	Level
7	Lock torso articulation			

#### 4.7.3 Load the cushion pan

There are two types of weights for loading the cushion pan; pelvic weights, which are positioned in slots along the H-point axis, and thigh weights that are held in place by the pins in the thigh area.

Punch the HPM twice at the cushion pan load application point (see Figure 5). Install two pelvic weights in the innermost pelvic weight slots (one to either side of the H-point). Install two thigh weights (one to either side). Check for level.

Repeat these steps (punch twice, load two pelvic weights, load two thigh weights, and level) two more times to complete the loading of the cushion pan.

#### 4.7.4 Load the back pan

There are two areas for loading weights on the back pan assembly, the lower and upper racks. However, the same type of weight is used in both areas.

When auditing the vehicle, but not the seat build, adjust the seat cushion or seat back recliner if necessary during the loading to obtain a final cushion and torso angle that equals design intent (see 4.5.2.3). The adjustments should be made after checking the cushion or back pan for level in each round shown in Table 3.

Punch the HPM twice at the back pan load application point (see Figure 5). Install two weights on the lower racks — one on either side of centreline. Push the weights toward the centreline as far as possible. Install two weights on the upper racks, one on either side of centreline, and push towards the centreline. Check for level.

Repeat these steps (punch twice, load two weights on the lower rack, load two weights on the upper rack, and level) two more times.

After the back pan is fully loaded and level, lock the torso articulation mechanism.

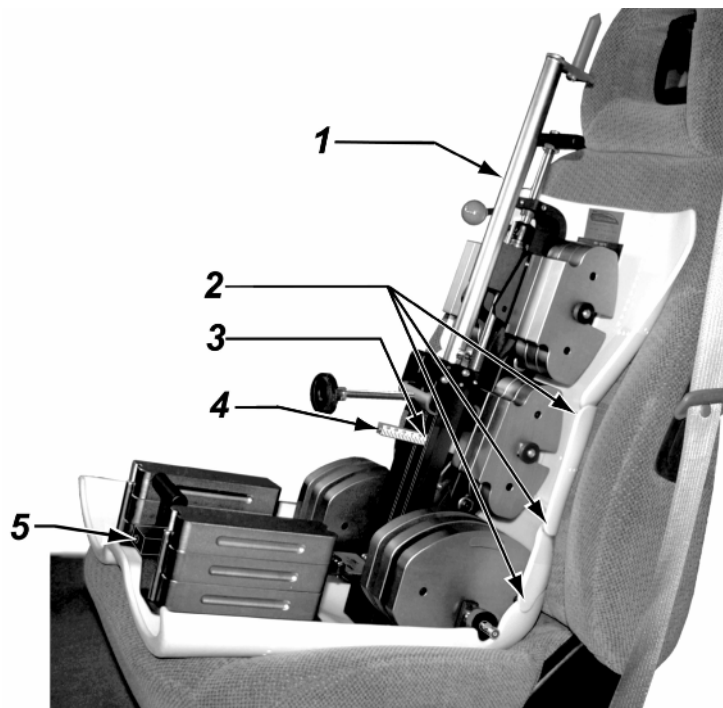

#### Key

- 1 headroom probe setting for measuring torso angle and LSP
- 2 correct overlap of back pan segments
- 3 LSP indication
- 4 back pan load application point
- 5 cushion pan load application point

**Figure 5 — H-point machine installed in a seat**

#### 4.8 Soak time

After installation, the HPM can continue to “settle” into a seat, depending on the type of seat being used. Therefore, the installer should wait 5 min after completing the HPM installation before recording data.

## 4.9 Record measurements — digitize HPM points

### 4.9.1 General

The HPM allows the H-point location, torso angle, LSP, and cushion angle to be defined without having to attach the legs.

### 4.9.2 H-point

The H-point is located at the lateral centreline of the HPM. Therefore, this point cannot be directly digitized. Rather, divot points H1L and H1R are provided for digitizing at either end of the H-point rods (see Figure 4). If either H1L or H1R is not readily accessible by the CMM, use divots H2L and H2R. Both H1L and H1R or H2L and H2R should be digitized. The H-point is midway between these two points. Divot points B1, B2 and C1 may be used to establish the HPM centreplane in CAD to check the  $y$ -coordinate of the H-point.

The digitized H-point, which represents the measured SgRP or R-point, shall be compared to the design SgRP or R-point to assess the accuracy of the seat build.

### 4.9.3 Torso angle and cushion angle

Record the following measurements using an inclinometer and the appropriate land: torso angle, using the headroom fixture land or back assembly land; cushion angle, using the cushion pan inclinometer land. As an alternative, the torso angle can be calculated from divot points H1L, H1R and B1, and the cushion angle from divot points H1L, H1R and C1. H2L and H2R can be used in lieu of the H1 divots.

### 4.9.4 Lumbar support prominence

The HPM provides a scale on the back pan assembly for a direct read-out of the LSP (Figure 5).

### 4.9.5 Summary of driver measurements

Table 4 shows the standard and optional measurements for the driver seat position.

**Table 4 — Driver measurements**

SAE J1100 Code <sup>a</sup>	Dimension
L31, W20, H70	SgRP $x$ -, $y$ -, and $z$ -coordinates
A40	Torso angle
A27	Cushion angle
L81	LSP
<b>Optional measurements (leg and shoe attached)</b>	
L8, W8, H8	AHP $x$ -, $y$ -, and $z$ -coordinates
L1, W1, H1	BOFRP $x$ -, $y$ -, and $z$ -coordinates
PW86	BOFRP to AHP lateral offset
A47	SPA
A57	Thigh angle
A42	Hip angle
A44	Knee angle
A46	Ankle angle
H30	Seat height
H61	Effective headroom
L33	Maximum legroom
L34	Effective legroom

## 5 Optional measurements for driver seat

### 5.1 Leg and shoe installations

#### 5.1.1 General

If the user plans to measure shoe and leg dimensions, the shoe fixture and shoe tool should be installed before the HPM cushion and back pans are installed (see Table 1). The shoe tool is used to establish the BOFRP and the AHP for the driver.

#### 5.1.2 Mark accelerator pedal centreline

Before installing the shoe tool in the driver compartment, place masking tape down the longitudinal centre of the accelerator pedal, and draw a line along the accelerator centreline.

#### 5.1.3 Install the shoe fixture

The shoe fixture is used to hold the shoe level and in place on the pedal (Figure A.4). Position the forward edge of the shoe fixture approximately 100 mm to 150 mm rearward of the accelerator pedal such that the fork that is to hold the shoe tool is in line with the accelerator centreline. The fixture shall be square to the grid and level. Adjust the screws on the shoe fixture until it is level.

#### 5.1.4 Install the shoe tool

##### 5.1.4.1 Procedure

Place the shoe in the fixture, set the shoe plane angle (SPA) at the manufacturer specified angle, tighten the shoe locking screw to hold the shoe in place and slide the shoe forward. The shoe shall be positioned with the heel on the depressed floor covering, the bottom of shoe contacting the pedal face and the BOF aligned with the pedal centreline. For flat, free-pivoting pedal pads, the bottom of the shoe should be flush with the face of the pedal. When there is a single point of contact, that point is the pedal contact point (PCP). Where there is continuous contact, e.g. with a suspended, flat pivoting pedal, there is not a specific PCP. See Figure 8.

If the manufacturer does not specify the SPA, calculate it from Equation (1) as follows:

$$\alpha_{SP} = \left(2,522 \times 10^{-7} \times h_z^3\right) - \left(3,961 \times 10^{-4} \times h_z^2\right) + \left(4,644 \times 10^{-2} \times h_z\right) + 73,374 \quad (1)$$

where

$\alpha_{SP}$  is the SPA, expressed in degrees from the horizontal;

$h_z$  is the seat height, in millimetres (dimension code H30 in SAE J1100).

Check to make sure the shoe tool is square to the grid. Adjust the fixture and shoe if necessary.

The SPA can be measured directly by placing the inclinometer on the rearward-facing surface of the shoe. Alternatively the SPA,  $\alpha_{SP}$ , can be calculated from the  $z$ -coordinates of divot points S3 and S2 as follows.

$$\alpha_{SP} = \arcsin\left(\frac{z_{S3} - z_{S2}}{94}\right) \quad (2)$$

where

$z_{S3}$  is the  $z$ -coordinate of the S3 divot point, in millimetres;

$z_{S2}$  is the  $z$ -coordinate of the S2 divot point, in millimetres.

### 5.1.4.2 Interference

Occasionally, some aspect of the vehicle's structure, e.g. the tunnel, rocker or centre console, prevents the positioning of the shoe tool and fixture as specified in 5.1.4. If the interference prevents the shoe tool from being properly positioned at the accelerator centreline, the shoe and fixture shall be shifted laterally until the interference is cleared. The amount of the lateral offset, PW86, should be recorded. The BOFRP is defined at the centreline of the accelerator pedal, even though the shoe BOF is not at the centreline. The AHP is defined at the location of the heel of shoe (HOS) after the shoe tool is moved to clear the interference (see Figure 6).

In some cases the shoe tool may fit properly, but the shoe fixture cannot. The tool and fixture still need to be moved to clear the interference, but the AHP location is defined as if the shoe were aligned at the pedal centreline. In other words, the AHP coordinates are defined as if the shoe had remained positioned on the pedal centreline with no interference. This translation is most easily done in CAD.

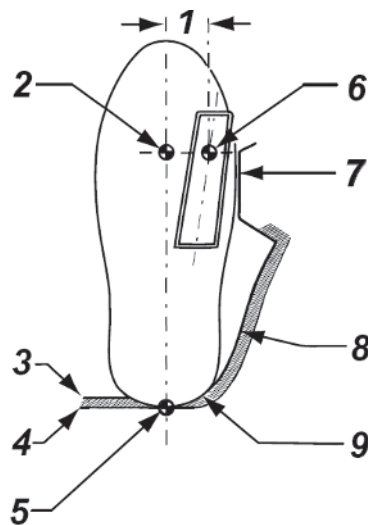

#### Key

- 1 PW86 (lateral offset dimension code from SAE J1100)
- 2 BOF
- 3 undepressed floor covering
- 4 depressed floor covering
- 5 AHP
- 6 BOFRP
- 7 interference at side of shoe
- 8 edge of tunnel or center console
- 9 interference at side of heel

Figure 6 — AHP to BOFRP lateral offset

### 5.1.5 Install leg segments

When taking the shoe and leg measurements in 5.2 and 6.2 for the purpose of reporting these dimensions to outside organizations, set the leg segments at the SgRP leg lengths, i.e. pin the thigh length to 456 mm and the lower leg to 459 mm. Manufacturers may use non-SgRP leg lengths for other purposes.

Install the thigh segment by placing the forks on the H-point rods. Slide the locking bushings inward and rotate until the pins lock into place (see Figures 4 and 7). Install the lower leg at the ankle pivot without moving the shoe. Join the thigh and lower leg segments, raising the thigh segment if necessary. Use the bushing on the knee pivot rod to secure the lower leg in place.

The completed HPM installation, including optional components, is shown in Figure 7 for the driver seating position. Optional components include the HPM legs, shoe tool and shoe fixture, and the headroom probe.

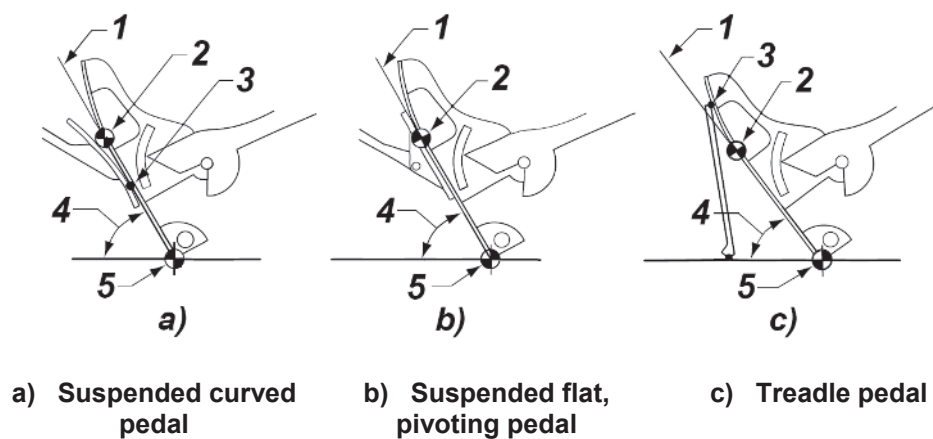

Figure 7 — Perspective view of HPM, including optional components

## 5.2 Record measurements

### 5.2.1 General

The shoe measurements (5.2.2, 5.2.3, 5.2.4 and 5.2.5) should be recorded immediately after installation of the shoe tool (see Figure 8).



#### Key

- |              |       |
|--------------|-------|
| 1 shoe plane | 4 SPA |
| 2 BOFRP      | 5 AHP |
| 3 PCP        |       |

Figure 8 — Shoe reference points related to accelerator pedal

### 5.2.2 Shoe plane angle

Record the SPA determined in 5.1.4.

### 5.2.3 Ball of foot reference point

The BOF point can be digitized directly, or it can be calculated using Equations (3) and (4).

$$x_{\text{BOF}} = x_{\text{S3}} - 25 \cos(\alpha_{\text{SP}}) - 5 \sin(\alpha_{\text{SP}}) \quad (3)$$

$$z_{\text{BOF}} = z_{\text{S3}} + 25 \sin(\alpha_{\text{SP}}) - 5 \cos(\alpha_{\text{SP}}) \quad (4)$$

where

$x_{\text{BOF}}$  is the  $x$ -coordinate of the BOF or BOFRP;

$z_{\text{BOF}}$  is the  $z$ -coordinate of the BOF or BOFRP;

$x_{\text{S3}}$  is the  $x$ -coordinate of the S3 divot point, in millimetres;

$z_{\text{S3}}$  is the  $z$ -coordinate of the S3 divot point, in millimetres;

$\alpha_{\text{SP}}$  is the SPA.

The location of the PCP relative to the BOFRP can be measured by a scale on the shoe tool (see Figure 9). The PCP may be digitized, if desired.

### 5.2.4 Accelerator heel point

The AHP cannot be directly digitized. It can be calculated using the shoe divot points (S2 and S3), and Equations (5) and (6).

$$x_{\text{AHP}} = x_{\text{S3}} + 175 \cos(\alpha_{\text{SP}}) - 5 \sin(\alpha_{\text{SP}}) \quad (5)$$

$$z_{\text{AHP}} = z_{\text{S3}} - 175 \sin(\alpha_{\text{SP}}) - 5 \cos(\alpha_{\text{SP}}) \quad (6)$$

where

$x_{\text{AHP}}$  is the  $x$ -coordinate of the AHP;

$z_{\text{AHP}}$  is the  $z$ -coordinate of the AHP;

$x_{\text{S3}}$  is the  $x$ -coordinate of the S3 divot point, in millimetres;

$z_{\text{S3}}$  is the  $z$ -coordinate of the S3 divot point, in millimetres;

$\alpha_{\text{SP}}$  is the SPA.

The  $y$ -coordinates,  $y_{\text{AHP}}$  and  $y_{\text{BOF}}$ , are defined at the shoe centreline, and can also be determined from the shoe divot point locations. The S2 and S3 divot points are offset 10 mm to either side of the shoe centreline. The direction of the 10 mm correction to a shoe divot  $y$ -coordinate depends on which side of the shoe was digitized (see Figure 9).

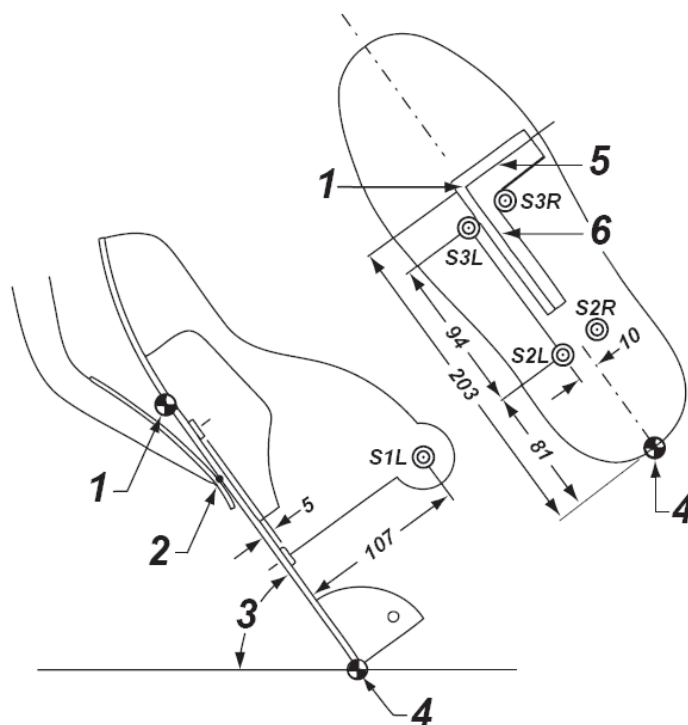

**Key**

- |         |                                     |
|---------|-------------------------------------|
| 1 BOFRP | 4 AHP                               |
| 2 PCP   | 5 BOFRP to AHP lateral offset scale |
| 3 SPA   | 6 BOFRP to PCP offset scale         |

**Figure 9 — Shoe divot points**

**5.2.5 Accelerator heel point to ball of foot reference point lateral offset**

The AHP to BOFRP lateral offset, PW86, can be read off the AHP to BOFRP lateral offset scale (see Figure 6). This offset is used to correct the *y*-coordinate of the BOFRP, if necessary.

**5.2.6 Knee angle and ankle angle**

Both knee angle and ankle angle can be read directly on the scales provided.

**5.2.7 Thigh angle and hip angle**

The thigh angle is measured using an inclinometer and the inclinometer land provided on the upper leg segment (see Figures A.3 and A.8)

The hip angle,  $\alpha_{hip}$ , in degrees, can be calculated using Equation 7):

$$\alpha_{hip} = 90 - \alpha_{thigh} + \alpha_{torso} \tag{7}$$

where

$\alpha_{thigh}$  is the thigh angle;

$\alpha_{torso}$  is the torso angle.



## 6 Optional measurements for the 2nd or succeeding row passenger seats

### 6.1 Leg and shoe installation

#### 6.1.1 General

If the user plans to measure shoe and leg dimensions, the shoe tool should be installed before the HPM cushion and back pans. The shoe tool is used to establish the FRP and floor plane angle for passengers. The leg segments are used to measure minimum knee clearance, effective legroom, as well as hip, thigh, knee, and ankle angles. These dimensions are defined in SAE J1100.

The shoe installation differs from the procedure described for driver's seats, but the leg and thigh installations are the same. The shoe fixture is not needed for passenger seat positions.

#### 6.1.2 Install the shoe tool

Place the shoe tool on the floor and slide it forward, beneath the seat in front, until it reaches an obstruction. The shoe can be placed anywhere within  $\pm 127$  mm of occupant centreline, and should be positioned such that its movement forward is optimized [see Figure 10 a)].

If the shoe cannot fit on the floor between the test seat and the preceding seat, measurement of knee clearance (L48), leg clearance (L58), and legroom (L51) is best done in CAD. If a physical installation of the HPM shoe and legs is desired, move the preceding seat forward along its seat adjustment path until the shoe just fits between the seats when the shoe is on the floor and against the trim under the test seat [Figure 10 c)]. Move the shoe laterally within  $\pm 127$  mm of the occupant centreline, keeping the shoe on the floor and against the trim under the test seat, to find the location that requires the least amount of preceding seat movement. Record the seat movement. This movement shall be subtracted from the legroom measured in 6.2.4 [see Figures 10 c) and 11].

If the shoe cannot fit and the preceding seat does not have fore/aft adjustment, then measurement of knee clearance, leg clearance, and legroom shall be done in CAD. Move the seat horizontally forward in CAD to determine the amount to be subtracted from legroom.

**NOTE** The H-point design (HPD) shoe shown in Annex D, along with the lower leg and thigh, can be installed in CAD, if the preceding seat back, trim under the test seat, and the floor were digitized.

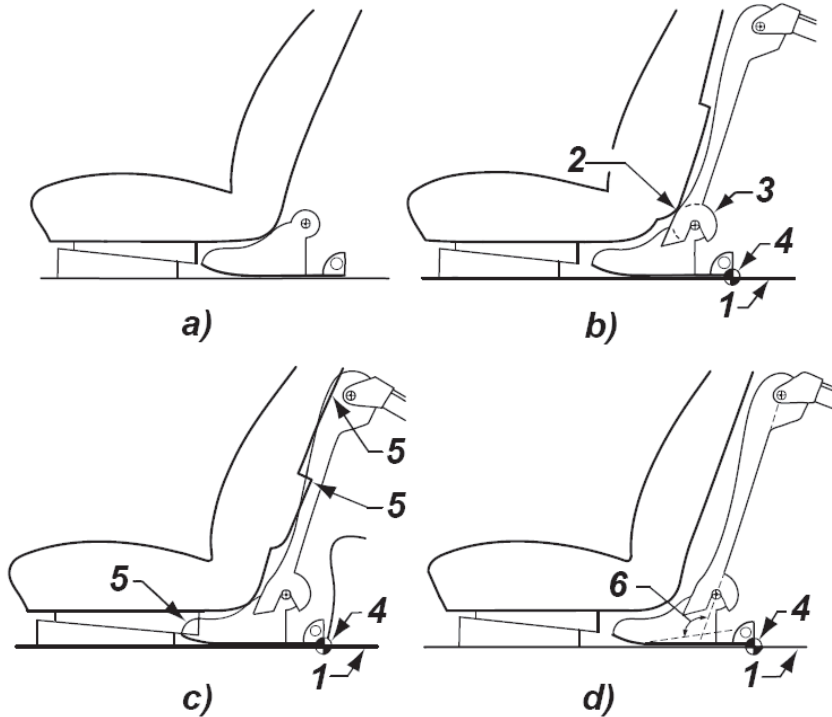

a) Position shoe as far forward as possible

b) Shoe may need to be moved rearward to eliminate ankle interference with lower seat back trim

c) Short-coupled seating: the seat interferes with the knee, leg, or shoe, requiring the seat be moved forward to allow installation of the leg/shoe

d) Long-coupled seating: the shoe is moved rearward so the lower leg reaches the shoe with an ankle angle no more than 130°

**Key**

- 1 depressed floor covering
- 2 interference at ankle
- 3 ankle circumference
- 4 FRP
- 5 interference at knee, lower leg, or shoe
- 6 maximum ankle angle is 130°

**Figure 10 — Shoe and leg installation for rear passenger seats**

**6.1.3 Install leg segments**

**6.1.3.1 General**

Install the thigh segment and lower leg segment as for the driver (see 5.1.5). In some vehicles, the thigh and lower leg/ankle segments cannot be attached without first repositioning the shoe tool or moving the preceding seat forward (see Figure 10, 6.1.3.2, and 6.1.3.3).

### 6.1.3.2 Reposition the shoe tool (if necessary)

#### 6.1.3.2.1 Conditional checks

There are two conditions under which the shoe tool needs to be moved rearward:

- a) interference between the preceding seat back or seat trim and the ankle circumference of the lower leg segment or shoe tool [Figure 10 b)];
- b) the lower leg segment does not reach the shoe tool, or, if it does reach, the ankle angle exceeds  $130^\circ$  [Figure 10 d)]. This condition is called long-coupled seating.

In either of these events, the shoe tool shall be repositioned before FRP or floor plane angle can be defined.

#### 6.1.3.2.2 Interference

Temporarily attach only the lower leg to the shoe to determine if there is interference in the area of the ankle pivot circumference on the lower leg [Figure 10 b)]. If there is interference at the ankle circumference, move the shoe rearward to just clear the interference. Interference *above* the ankle pivot circumference is not considered for positioning the shoe, but is considered when determining knee or leg interferences with short-coupled seating. Use this shoe position to define the FRP, floor plane angle, and all other dimensions.

If there is interference above the ankle circumference, proceed to 6.1.3.3. Otherwise, attach the thigh and lower leg segments now (see 5.1.5).

#### 6.1.3.2.3 Long-coupled seating

Prior to moving the shoe rearward, record the ankle pivot point (S1 divot) so that legroom can be correctly calculated. Move the shoe rearward until the cushion pan-thigh-lower leg assembly can be attached to the shoe tool at the ankle pivot point, with an ankle angle of  $130^\circ$ . Use this shoe position to establish the FRP, floor plane angle, and all other dimensions except legroom.

#### 6.1.3.3 Short-coupled seating

In vehicles with short-coupled seating, the knee or the lower leg segment interferes with the seat back of the seat directly ahead [Figure 11 b)]. In this case, mark the SgRP location of the preceding seat. Move the preceding seat forward to allow the lower leg and thigh to be installed. Do not move the shoe.

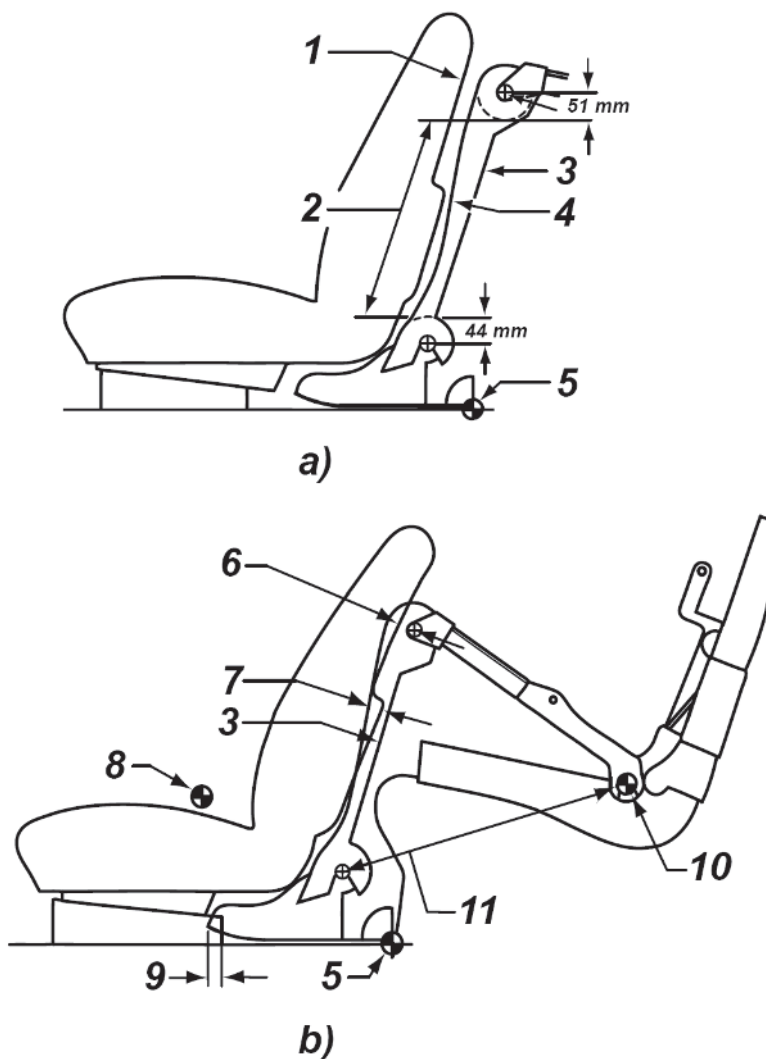

a) Leg and knee clearances

b) Shoe, leg, and knee interferences

**Key**

- 1 knee clearance (L48): knee pivot center to seat back trim minus 51 mm
- 2 leg clearance/interference zone
- 3 leg line
- 4 leg clearance (L58): minimum distance between front of leg and seat back trim measured normal to leg line
- 5 FRP
- 6 negative knee clearance
- 7 negative leg clearance: maximum distance from front of leg to seat back trim measured normal to leg line
- 8 SgRP-front
- 9 shoe interference (non-adjustable portion of seat)
- 10 SgRP-second
- 11 legroom (L51): H-point to ankle pivot plus 254 mm minus shoe interference

**Figure 11 — Knee clearance, leg clearance, and legroom for short-coupled seating**

## 6.2 Record measurements for rear passengers

### 6.2.1 Summary of measurements

The completed HPM installation is shown in Figure 12 for the rear outboard seating position.

For knee angle, thigh angle, hip angle, and ankle angle proceed in the same way as for the driver seat (see 5.2.6 and 5.2.7).



Figure 12 — H-point machine installed in rear outboard seat

Table 5 lists the passenger measurements that can be taken.

**Table 5 — Rear passenger measurements**

SAE J1100 code <sup>a</sup>	Dimension
L31, W20, H70	SgRP <i>x</i> -, <i>y</i> -, and <i>z</i> -coordinates
A40	Torso angle
A27	Cushion angle
<b>Optional measurements (leg and shoe attached)</b>	
L98, W98, H98	FRP <i>x</i> -, <i>y</i> -, and <i>z</i> - coordinates
A48	Floor plane angle
A57	Thigh angle
A42	Hip angle
A44	Knee angle
A46	Ankle angle
L81	LSP
H30	Seat height
H61	Effective headroom
L48	Knee clearance
L58	Leg clearance
L51	Effective legroom
<sup>a</sup> A suffix (-2, -3, ...) that denotes the seat row shall be added to each dimension code.	

### 6.2.2 Floor reference point

The shoe divot points can be digitized, and the FRP calculated by using Equations (5) and (6). Other divot points can be digitized if desired.

### 6.2.3 Floor plane angle

The floor plane angle,  $\alpha_{FP}$ , can be measured directly by placing the inclinometer on the rearward-facing surface of the shoe. Alternatively the floor plane angle, in degrees, can be calculated from the *z*-coordinates of the shoe divot points S3 and S2 by using Equation (8).

$$\alpha_{FP} = \arcsin\left(\frac{z_{S3} - z_{S2}}{94}\right) \quad (8)$$

where

$z_{S3}$  is the *z*-coordinate of the S3 divot point, in millimetres;

$z_{S2}$  is the *z*-coordinate of the S3 divot point, in millimetres.

## 6.2.4 Knee clearance and legroom

Knee clearance is the minimum distance between the knee pivot point (K1 divot) and the preceding seat back, minus 51 mm (see Figure 11). The measurement is taken within 127 mm to either side of the occupant centreline. This measurement is best done in CAD from a scan of the preceding seat back in the vicinity of the K1 divot point and lower leg of the HPM. Knee clearance is a negative value if the knee interferes with the preceding seat back. See SAE J1100 for a decision tree explaining long- and short-couple CAD procedures.

If there is interference below the knee and above the ankle circumference, use the leg clearance dimension (L58) in SAE J1100 to determine the amount of interference. For short-coupled seating, measurement of knee and leg interferences shall be done in CAD.

Legroom is the distance along a line from the ankle pivot centre (S1 divot point) to the SgRP, plus 254 mm, measured within 127 mm to either side of the occupant centreline, with the HOS at the FRP. The knee clearance and leg room measurements are shown in Figure 11 for a short-coupled vehicle.

## 7 Additional optional measurements

### 7.1 Effective headroom

#### 7.1.1 When to install headroom fixture

If the user plans to measure headroom (H61), the headroom fixture should be installed immediately after the HPM cushion and back pans are installed, before weights are added (see Table 1).

#### 7.1.2 Install the headroom fixture

Slide the forks at the end of the headroom fixture into the grooves on the brass locking bushings of the cushion pan. With the adjuster screw fully out, snap the end of the screw into the rotating tumbler on the back pan (see Figures 4 and 13). Ensure the fixture is fully against the stop on the back pan. Then proceed with 4.6.3.

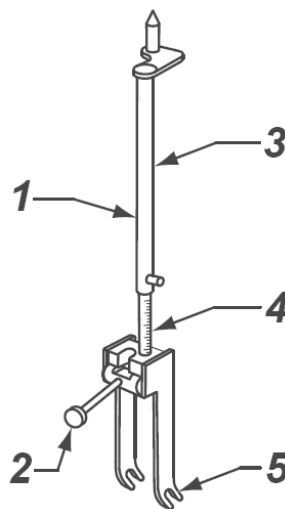

#### Key

- 1 inclinometer land for torso angle
- 2 angle adjusting screw
- 3 sliding tube with headroom probe
- 4 effective headroom scale
- 5 attaching fork

Figure 13 — Headroom fixture

### 7.1.3 Measure effective headroom

Effective headroom can be measured using the scale inside the headroom fixture. First, turn the adjuster screw until the torso angle is at 8° rearward of vertical (use the inclinometer on the headroom fixture land). Then pull up the probe in the headroom fixture so that it lightly contacts the headliner. Read the measurement from the scale on the headroom probe.

## 8 Remove the HPM

To aid in removing the HPM, seats may be moved, unless a subsequent HPM installation is to be made in the succeeding row.

Remove lower leg segment, if installed.

Remove thigh segment if installed.

Weights are removed from the HPM in the reverse order that they were installed. Unload the HPM following the removal order of Table 6.

**Table 6 — Unloading the HPM**

Round	Remove two weights from	Then remove two weights from
1	Outermost upper rack	Outermost lower rack
2	Next outermost upper rack	Next outermost lower rack
3	Innermost upper rack	Innermost lower rack
4	Thigh	Outermost PELVIC
5	Thigh	Next outermost PELVIC
6	Thigh	Innermost PELVIC

Remove headroom fixture, if installed.

Remove cushion and back pans: Unlock the torso articulation mechanism, position the back pan in a slouched posture, and re-lock the mechanism. Slide the brass locking bushings outward and remove the back pan. Remove the cushion pan. Alternatively the cushion and back pan can be removed as a single unit.

Remove shoe tool and shoe fixture, if installed.



## Annex A (normative)

### Description of the three-dimensional H-point machine (HPM)

#### A.1 Major components

##### A.1.1 General

This annex provides descriptions of the parts and some basic dimensions of the HPM<sup>3)</sup>. Complete dimensional information can be found in Annex B.

For the HPM, the leg segments (thigh and lower leg), shoe tool, cushion pan, and back pan assembly are all separate pieces (see Figure A.1).

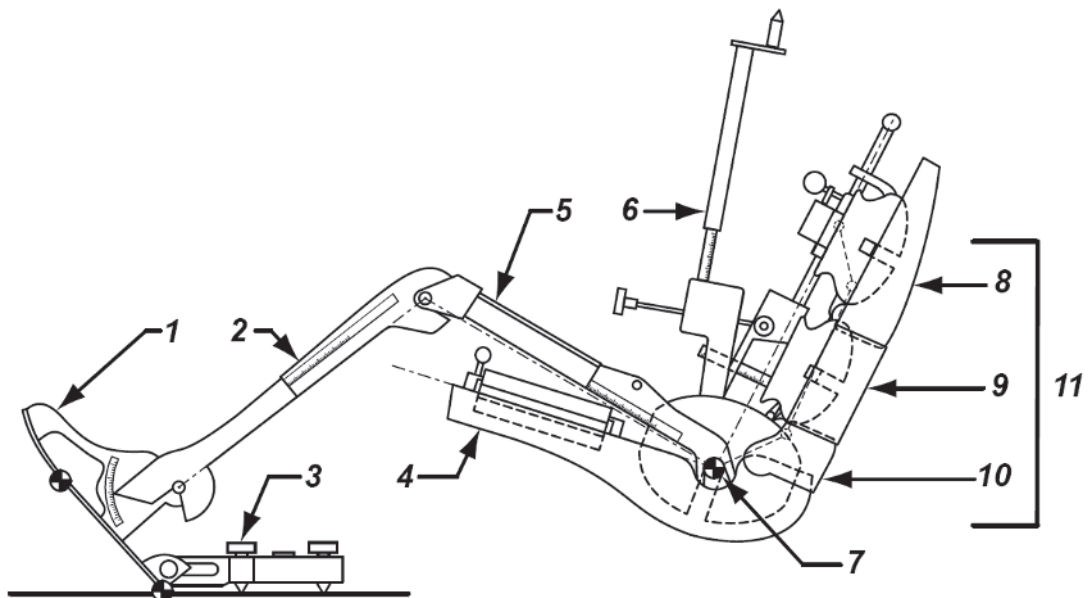

#### Key

- 1 shoe
- 2 lower leg
- 3 shoe fixture
- 4 cushion pan
- 5 thigh
- 6 headroom probe
- 7 H-point
- 8 thoracic segment
- 9 lumbar segment
- 10 pelvic segment
- 11 back pan segments

Figure A.1 — Major new HPM components

3) The HPM is available from the Society of Automotive Engineers, Warrendale, PA, USA. This information is given for the convenience of users of this document and does not constitute an endorsement by ISO of the product named.

### **A.1.2 Back pan assembly**

The back pan assembly consists of the back pan with its thoracic, lumbar, and pelvic segments. It contains the following parts (see Figure 3):

- a) handle;
- b) torso articulation locking lever;
- c) H-point pivot shaft (sits on H-point saddle);
- d) load application point (receptacle for spring-loaded probe);
- e) torso angle inclinometer land;
- f) upper weight rack;
- g) lower weight rack.

### **A.1.3 Cushion pan**

The cushion pan assembly contains (see Figure 4):

- a) cushion pan;
- b) handle;
- c) H-point saddle with pelvic weight locations;
- d) H-point rods;
- e) locking bushings for attaching back pan;
- f) locking bushings for attaching thigh segment;
- g) load application point for spring probe;
- h) lateral level;
- i) thigh weight platform and locating pins.

### **A.1.4 Lower leg segment**

The lower leg segment includes (see Figure A.2):

- a) knee pivot slot;
- b) leg length scale;
- c) leg length locking pin;
- d) leg length locking screws;
- e) knee angle scale;
- f) lower leg angle inclinometer land.

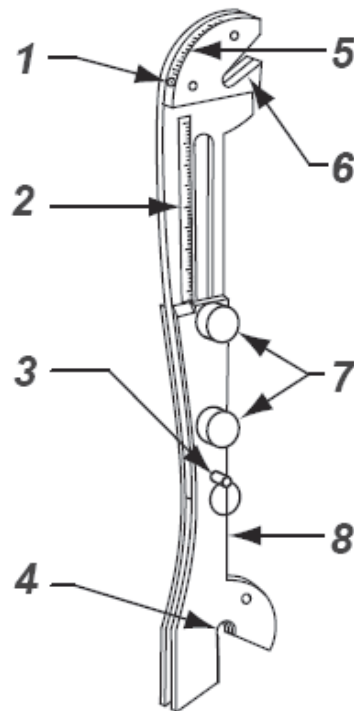

**Key**

- 1 K2 divot
- 2 leg length scale
- 3 locking pin
- 4 ankle pivot slot
- 5 knee angle scale
- 6 knee pivot slot
- 7 locking screws
- 8 inclinometer land for lower leg angle

**Figure A.2 — Lower leg segment**

**A.1.5 Thigh segment**

**A.1.5.1 Elements**

The thigh segment consists of (see Figure A.3):

- a) locking bushing (for attaching lower leg);
- b) knee pivot rod;
- c) thigh length scales;
- d) thigh length locking pins;
- e) thigh length locking screws;
- f) fork (for attaching to H-point rod);
- g) lateral leg position scale;
- h) thigh angle inclinometer land.

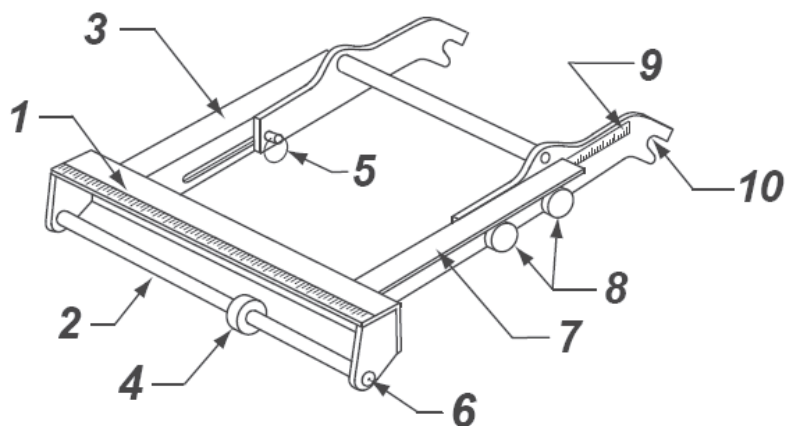

**Key**

- 1 lateral leg position scale
- 2 knee pivot rod
- 3 inclinometer land for thigh angle
- 4 locking bushing
- 5 locking pin
- 6 K1L divot
- 7 inclinometer land for thigh angle
- 8 locking screws
- 9 thigh length scale
- 10 fork

**Figure A.3 — Thigh segment**

**A.1.5.2 Length of thigh and lower leg segments**

The length of the leg segments can be adjusted. However, for measurements related to the SgRP (or R-point), the SgRP leg length values shall be used (see Table A.1).

**Table A.1 — Leg segment lengths**

Leg segment	SgRP	Mid-size male
<b>Thigh</b> (knee pivot to H-point)	456 mm	432 mm
<b>Lower leg</b> (knee pivot to ankle pivot)	459 mm	417,5 mm

**A.1.6 Shoe tool and shoe fixture**

The BOF, HOS, and bottom of shoe are found on the shoe tool, and are key reference points or surfaces for using the H-point machine. BOF on the shoe tool is located at the zero marking (corner) of the two scales on the top surface of the shoe. Other parts of the shoe tool include (see Figure A.4):

- a) locking screw;
- b) ankle angle scale;
- c) AHP to BOFRP lateral offset scale;

- d) BOFRP to PCP scale;
- e) SPA inclinometer land.

The shoe fixture is used to hold the shoe tool in place on the accelerator (see Figure A.4):

- 1) 2 levelling screws
- 2) Bubble level
- 3) Fork for attaching the shoe tool

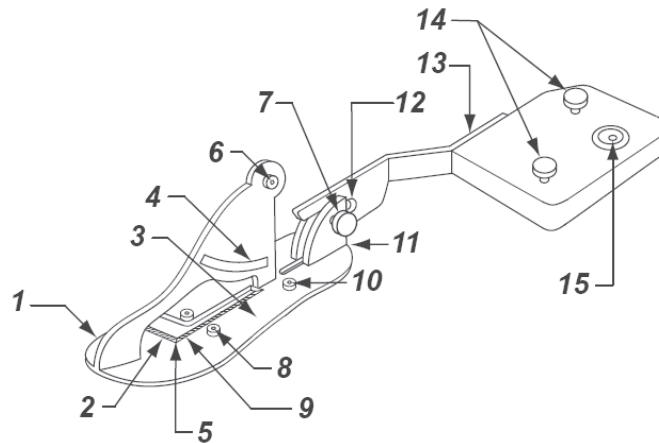

**Key**

- |                                     |                             |
|-------------------------------------|-----------------------------|
| 1 shoe                              | 9 BOFRP to PCP offset scale |
| 2 BOFRP to AHP lateral offset scale | 10 S2L divot                |
| 3 inclinometer land for SPA and FPA | 11 HOS                      |
| 4 ankle angle scale                 | 12 fork                     |
| 5 BOF                               | 13 shoe fixture             |
| 6 K1L divot                         | 14 levelling screws         |
| 7 locking screw                     | 15 bubble level             |
| 8 S3L divot                         |                             |

**Figure A.4 — Shoe tool and shoe fixture**

**A.1.7 Spring-loaded probe**

**A.1.7.1 Force**

The probe is used to deliver 89 N (20 lbf) of force at the appropriate load application points.

**A.1.7.2 Load application sites**

There are two sites for applying force using the spring-loaded probe; one on the cushion pan and one on the back pan (see Figures 3 and 4).

## **A.1.8 Inclinometer (electronic level)**

### **A.1.8.1 General**

An inclinometer is provided for determining various posture angles when using the HPM, including torso angle, thigh angle, cushion angle, and SPA. Specific sites for placing the inclinometer — referred to as lands — are provided on the appropriate components.

### **A.1.8.2 Inclinometer lands**

There are six locations provided for positioning the inclinometer: lower leg; thigh; headroom fixture; shoe tool; back pan; and cushion pan.

## **A.1.9 Weights**

The HPM comes with three types of weights: pelvic, thigh, and back. The total number of weights is 24: six pelvic, six thigh, and 12 back. Two of the pelvic weights have bevelled edges. See Annex B for a full specification.

### **A.1.10 Headroom fixture**

A separate fixture is provided for measuring effective headroom. The fixture consists of (see Figure 13):

- a) fork (for attaching to the HPM);
- b) an adjusting screw for setting the angle of the fixture;
- c) a land for measuring the angle of the fixture;
- d) a sliding tube with probe;
- e) effective headroom scale.

## **A.2 Reference points and angles**

### **A.2.1 Pivot locations**

The HPM can be articulated about six pivot locations: ankle pivot; knee pivot; H-point (where cushion and back pan are joined); lumbar-pelvic pivot; thoracic-lumbar pivot; and sliding thoracic pivot (see Figure A.5). In the HPM, the pivot point centres lie within the pivot mechanism.

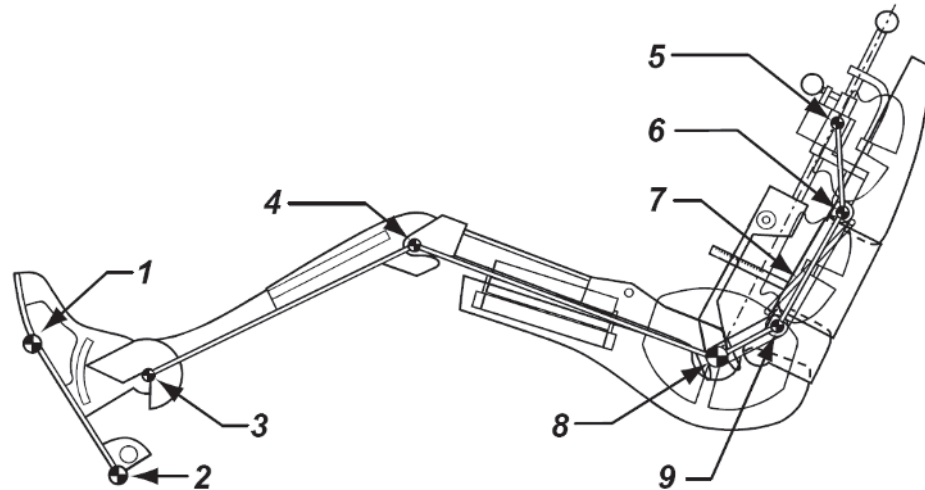

**Key**

- |                          |                         |
|--------------------------|-------------------------|
| 1 BOF                    | 6 thoracic-lumbar pivot |
| 2 HOS                    | 7 control link          |
| 3 ankle pivot            | 8 H-point               |
| 4 knee pivot             | 9 lumbar pivot          |
| 5 sliding thoracic pivot |                         |

**Figure A.5 — Pivot points**

**A.2.2 Support points**

There are nine support points: five are located on the bottom surface of the cushion pan and four on the outer surface of the back pan assembly (see Figure A.6). The support points are provided to facilitate seat design. Additional information can be found in Annex B.

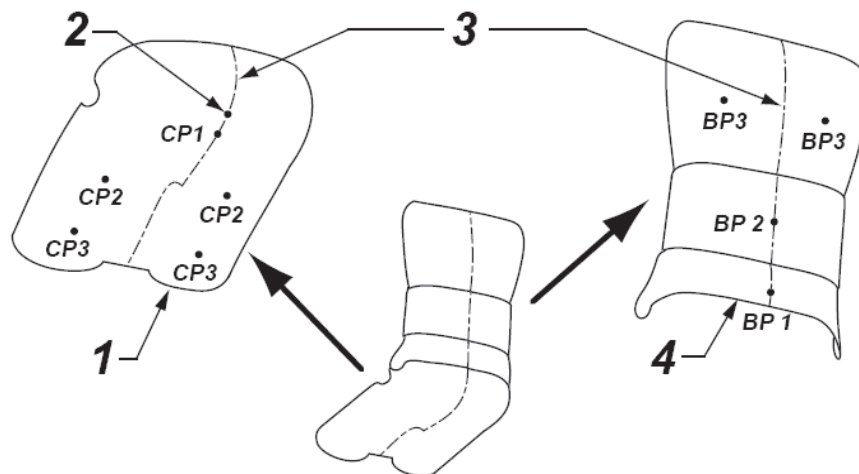

**Key**

- |                                 |
|---------------------------------|
| 1 bottom surface of cushion pan |
| 2 D-point                       |
| 3 centreline                    |
| 4 outer surface of back pan     |

**Figure A.6 — Support points**

### A.2.3 Divot points

On the HPM, 14 divot points are provided for use with CMM<sup>4)</sup> equipment (see Figure A.7). On the HPM, divot points are located in the centre of the small gold coloured disks on the mechanism. Specific locations of the divot points can be found in Annex B. The primary purpose of the divot points is to allow for the calculation of key reference points.

Dimensions in millimetres

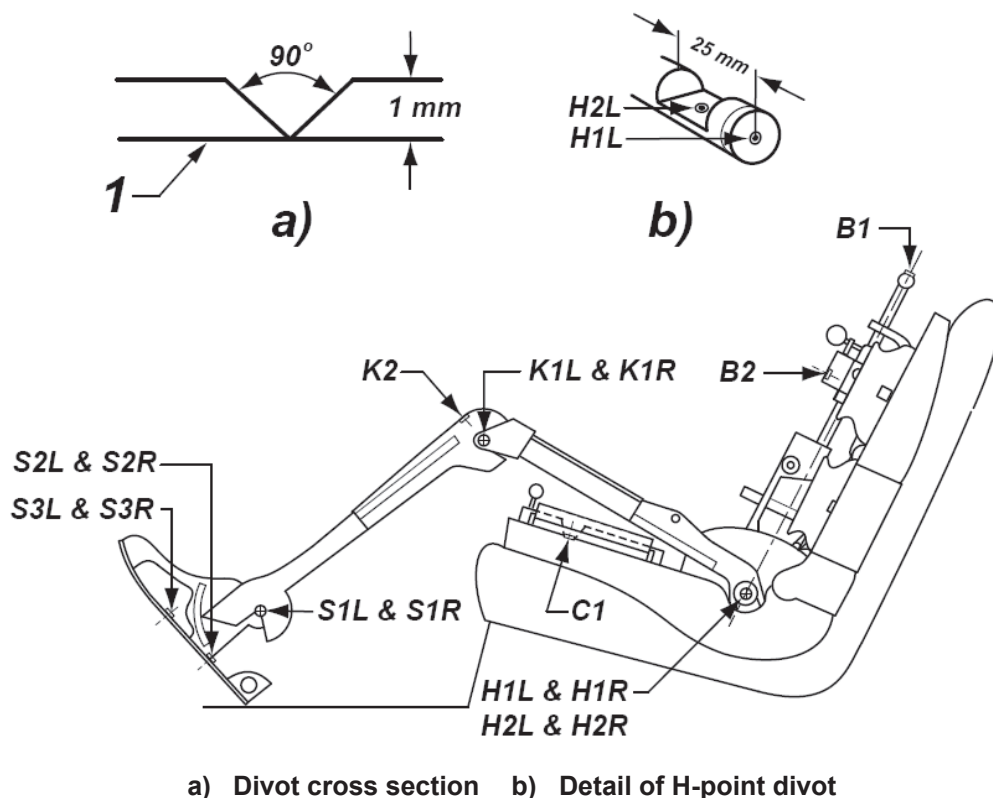

**Key**  
 1 reference surface

**Figure A.7 — Divot points on the HPM**

For example, the coordinates of H1L and H1R (or H2L and H2R) are required to calculate the H-point location. The coordinates of S1, S2, and S3 are required to calculate the location of the AHP (or FRP). Divot points can also be used to calculate with additional precision anything that can be measured directly from the HPM (e.g. torso angle, cushion angle, knee angle, LSP). See Table A.2.

4) A computer-assisted three-dimensional system for the measurement and digitization of physical properties. Typically, data from a CMM can be captured as individual points or streams of data. The 3D information provided includes the *x*-, *y*-, and *z*-coordinates of the points. This information can then be read into the appropriate CAD environment.



**Table A.2 — Divot point overview**

Divot type	Summary of use
Back pan divot points (B1, B2) and Cushion pan divot points (C1, H1R, H1L)	The B1 point can be used with the H1 or H2 points to define the torso angle. This can then be compared to B2 for a measure of lumbar support. The C1 point can be used with the H1 or H2 points to define the cushion angle. Additionally, B1 and B2 can be used together with C1 to define the centreline of the HPM.
H-point divot points (H1R, H1L)	The H1 or H2 points are used to define the H-point location. The measured H-point is located at the intersection of centreline of the HPM, the torso line and the cushion line. The H1 or H2 locations are averaged to define the $x$ -, $y$ -, and $z$ -coordinates of the H-point. (Alternatively, B1, B2, and C1 can be used to define the H-point $y$ -coordinate).
Shoe divot points (S1R, S1L, S2R, S2L, S3R, S3L)	Shoe divot points are used to define the AHP. They can also be used to define the BOFRP, the SPA, and the floor plane angle.
Knee divot points (K1L, K1R, K2)	Knee divot points can be used to locate the knee pivot point centre. By using this in combination with the S1 and H1 or H2 points, knee angle can be determined.

#### A.2.4 Key reference points and lines

For the HPM, the key reference points and reference lines need to be calculated using divot points. Table A.3 summarizes the HPM locations.

**Table A.3 — Key reference points and lines**

Reference point or line	Summary of location
<b>H-point</b>	The intersection of the cushion line and torso line corresponds to the pivot centre of the cushion pan and back pan. This point is within the mechanism, and shall be calculated using the divot points H1L and H1R or H2L and H2R. For additional accuracy, the divot points B1, B2, and C1 can be used to define the lateral centreline of the HPM.
<b>D-point</b>	Located on the bottom of the cushion pan, at the lateral centreline, 25,5 mm (15°) rearward of the H-point (when cushion angle equals 0). This point is identified by a divot point on the surface of the cushion pan (Figure A.6). However, when the HPM is installed, this point cannot be reached and so shall be calculated relative to the H-point.
<b>Heel of shoe</b>	The heel point is found at the bottom of the back of the shoe, at the lateral centreline. It is used to define the AHP for the driver, and the FRP for passengers. The heel point cannot be reached when the HPM is installed. The location shall be calculated using S1, S2, and S3 divot points.
<b>Ball of foot</b>	The BOF is located on the bottom of the shoe, at the lateral centreline, 203 mm from the heel point. It is used to define the BOFRP for the driver. BOF on the shoe tool is located at the zero marking (corner) of the 2 scales on the top surface of the shoe. A more precise location can be calculated using S1, S2, and S3 divot points.
<b>Torso line</b>	A line from the H-point through the sliding thoracic pivot (B1 divot point).
<b>Cushion line</b>	A line from the H-point through the C1 divot point.
<b>Thigh line</b>	A line from the H-point through the knee pivot K1.
<b>Leg line</b>	A line from the knee pivot K1 through the ankle pivot S1.
<b>Bottom of shoe</b>	A line in side view from the heel of shoe through the BOF. The angle of this line from horizontal defines the SPA (driver) or floor plane angle (passengers).
<b>Bare foot flesh line</b>	A line originating from a point 286,9 mm from the heel of shoe, on the bottom of shoe line, at a 6,5° angle. This line is provided on the HPD, but not on the HPM.

### A.2.5 Posture angles and LSP

The HPM can be used to determine posture angles. Several angles are summarized in Table A.4. The methods for taking the measurements refer to reference lines, divots, and lands. Torso and cushion angles, as well as LSP, can be measured without installing the legs. Other angles in Table A.4 require installation of the legs and shoe tool (see Figures A.7 and A.8).

**Table A.4 — Posture angles and LSP**

SAE J1100 Code	Posture angle	Location and measurement
A40	Torso angle	The angle of the torso line from vertical defines the torso angle. The torso angle can be measured by H1 (or H2) and B1 divots, or by placing the inclinometer on the torso angle land on the back pan assembly, or by the torso angle land on the headroom fixture with the fixture mounted flush to the back pan assembly.
A27	Cushion angle	The angle of the cushion line from horizontal defines the cushion angle. The cushion angle can be measured using H1 (or H2) and C1 divots or by placing the inclinometer on the cushion angle land on the cushion pan assembly.
A57	Thigh angle	The angle of the thigh line from horizontal defines the thigh angle. Thigh angle can be measured by using knee pivot K1 and the H-point (H1 or H2 divot) or by placing the inclinometer on the thigh angle land on the thigh assembly. Cushion and thigh angles are independent.
A42	Hip angle	The angle between the torso and thigh lines defines the hip angle. After the thigh and torso angles are measured, the hip angle can be calculated from Equation (7).
A44	Knee angle	The angle formed by the intersection of the thigh line and the leg line defines the knee angle. A direct read-out scale is provided on the leg segment. The angle can also be calculated using divot points S1, K1, and H1 or H2.
A46	Ankle angle	The angle between the lower leg and the bare foot flesh line forms the ankle angle. A direct read-out scale is provided on the shoe assembly.
A47, A48	Shoe plane angle or floor plane angle	The angle from horizontal to the bottom of the shoe forms the SPA or floor plane angle. The angle can be determined by using divot points S3 and S2, or by placing an inclinometer on the shoe plane and on the shoe.
L81	Lumbar support prominence	LSP is defined as $57 \text{ mm} - x$ , where $x$ is the distance between the lumbar-pelvic pivot to the torso line, measured normal to the torso line.  In the neutral posture, LSP equals zero so that the back pan has a flat lower back similar to the original H-point machine; the distance between the lumbar-pelvic pivot and the torso line is 57 mm. As LSP increases, the lumbar segment of the back pan assembly is pushed forward, the pelvic and thoracic segments are tipped, and the lumbar-pelvic pivot moves closer to the torso line (see Figure A.9).  For measurement, a direct read-out scale is provided on the back pan assembly.

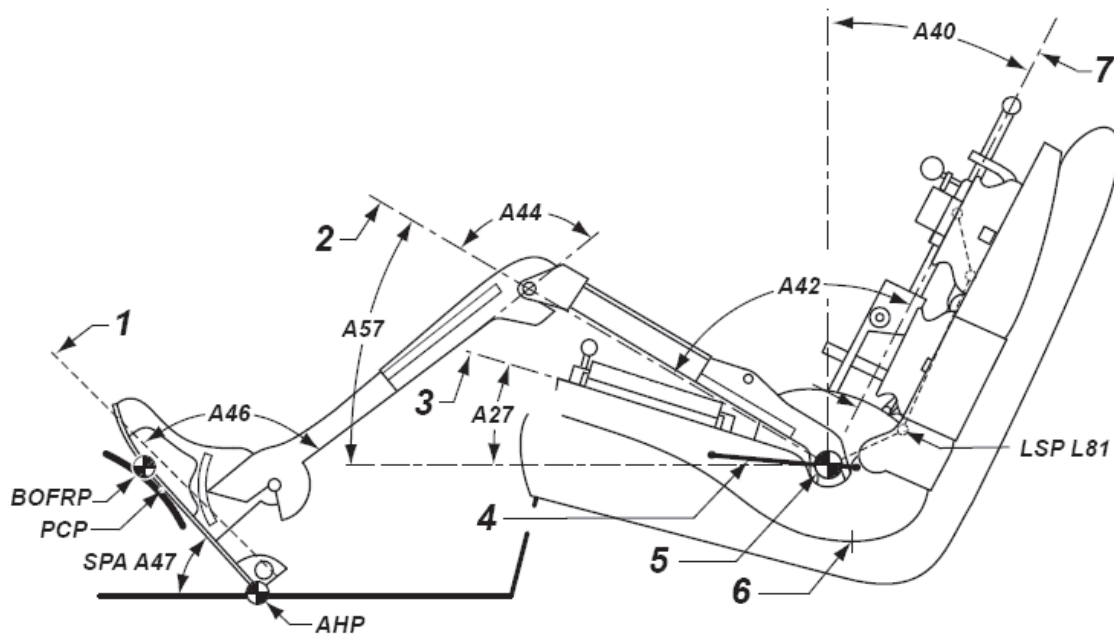

**Key**

- 1 bare foot flesh line
- 2 thigh line
- 3 cushion line
- 4 H-point travel path
- 5 H-point
- 6 D-point
- 7 torso line

**Figure A.8 — Reference points, reference lines, and posture angles**

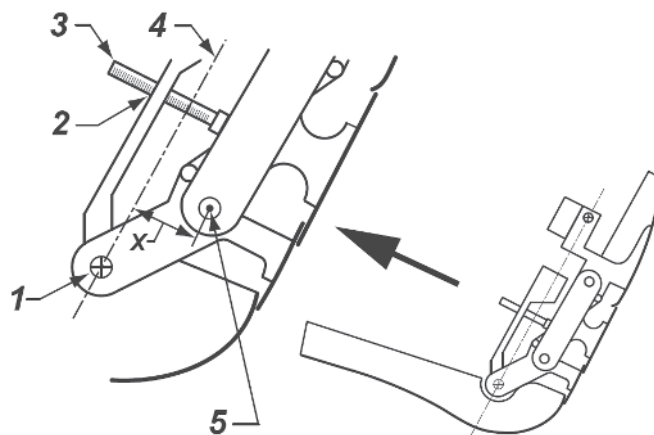

**Key**

- $x$  distance from torso line to lumbar-pelvic pivot
- 1 H-point pivot
- 2 LSP indication (L81) equal to  $57\text{ mm} - x$
- 3 LSP scale
- 4 torso line
- 5 lumbar-pelvic pivot

**Figure A.9 — Lumbar support prominence**

## **Annex B** (informative)

### **HPM specification and tolerances**

#### **B.1 Tolerances**

The following comments apply to all tolerances given in the tables of this annex.

HPM tolerances reflect acceptable dimensional variations that do not affect the overall performance measurements of the H-point machine. If conditions of use, wear or damage result in measurements that exceed the specified tolerance values, the HPM should be recalibrated.

The build tolerances of the HPM as produced by the HPM manufacturer are well below the tolerances specified in these tables.

#### **B.2 Reference posture for specifications**

Unless otherwise specified, all dimensions in this section are given in true vertical or true horizontal, with the device postured using the settings in Table B.1 (see Figure B.1).

Dimensions in millimetres

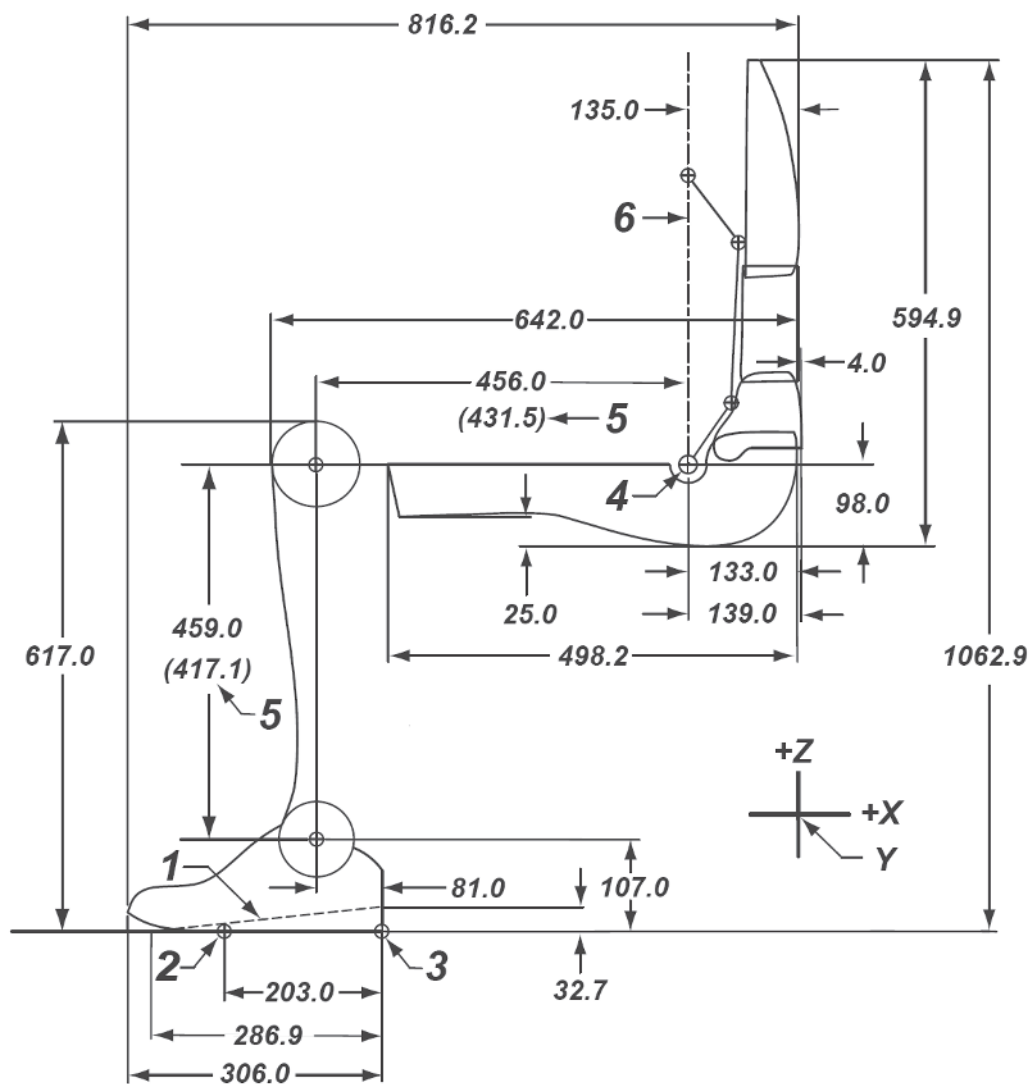

**Key**

- 1 bare foot flesh line
- 2 BOF (ball of foot)
- 3 HOS
- 4 H-point
- 5 dimension for mid-size male leg
- 6 torso line

**Figure B.1 — HPM lengths and heights, side view**

**Table B.1 — Posture of HPM for specifications**

Torso angle	0	degrees
LSP	0	mm
Cushion angle	0	degrees
Thigh angle	0	degrees
Knee angle	90	degrees
Ankle angle <sup>a</sup>	96,5	degrees
Thigh length	456	mm (SgRP)
Lower leg length	459	mm (SgRP)
<sup>a</sup> The bottom of the shoe is flat on the <i>xy</i> -plane. However, since ankle angle is measured from the bare foot flesh line, and not the bottom of shoe, the ankle angle will be 96,5°, not 90°.		

### B.3 Shoe tool dimensions

See Table B.2.

**Table B.2 — Shoe tool dimensions**

Dimension	Value
Overall length of shoe	306 mm
BOF to HOS distance	203 mm
Ankle pivot	107 mm above HOS 81 mm forward of HOS
Bare foot flesh line	65° above the bottom of shoe. Originates in shoe plane 286,9 mm forward of HOS
Relative to BOF	9,9 mm above
Relative to HOS	32,7 mm above

## B.4 Lengths

See Table B.3 and Figure B.1.

**Table B.3 — Lengths**

Dimensions in millimetres

Description	Value	HPM tolerance
Overall (rearmost to foremost)	816,0	±4,0
Overall, not counting shoe	642,0	±4,0
Cushion pan	498,2	±4,0
Shoe	306,0	±2,0
Heel of shoe to ball of foot	203,0	±2,0
Heel of shoe to ankle pivot	81,0	±2,0
Heel of shoe to origin of bare foot flesh line	286,9	—
H-point to knee pivot	456,0	±2,0
H-point to knee pivot, with mid-size male leg lengths	432,0	±2,0
H-point to back of cushion pan	133,0	±2,0
H-point to back of back pan	135,0	±2,0

## B.5 Widths

See Table B.4.

**Table B.4 — Widths**

Dimensions in millimetres

Description	Value	HPM tolerance
Cushion pan, max. (358 mm forward of H-Point)	405,8	±4,0
Cushion pan, at H-point	383,3	±4,0
Cushion pan, at D-point	371,0	±4,0
Cushion pan, at CP2 support points	401,0	±4,0
Cushion pan, at CP3 support points	405,1	±4,0
Back pan, max. (442 mm above H-point)	384,6	±4,0
Pelvic segment, at BP1 support point	373,7	±4,0
Lumbar segment, at BP2 support point	326,0	±4,0
Thoracic segment, at BP3 support point	360,3	±4,0
Shoe, max. (at ball of foot)	110,0	±2,0

## B.6 Heights

See Table B.5 and Figure B.1.

**Table B.5 — Heights**

Dimensions in millimetres

Description	Value	HPM tolerance
Overall	1062,9	±4,0
Seated height (bottom of cushion pan to top of device)	594,9	±4,0
Cushion pan, Max.	132,3	±4,0
Pelvic segment, max.	94,9	±4,0
Lumbar segment, max.	150,3	±4,0
Thoracic segment, max.	255,6	±4,0
Lumbar-pelvic pivot to bottom of cushion pan	180,8	±4,0
Thoracic-lumbar pivot to bottom of cushion pan	363,5	±4,0
H-point to bottom of cushion pan	98,0	±2,0
Heel of shoe to ankle pivot	107,0	±2,0
Heel of shoe to bare foot flesh line	32,7	—
Ball of foot to bare foot flesh line	9,9	—
Knee pivot point to ankle pivot point	459,0	±2,0
Knee pivot point to ankle pivot point, mid-size male	417,5	±2,0
Knee pivot point to “cross-over” of lower leg pieces	300,0	±1,0
Ankle pivot point to “cross-over” of lower leg pieces	159,0	±1,0
Top of knee to bottom of shoe	617,0	±2,0
Sole of shoe	3,2	±1,0

## B.7 Radii

The radius of the knee is 51 mm. The radius of the ankle on the shoe tool is 19,1 mm. The radius of the ankle curve at the lower end of the lower leg is 44,5 mm.



## B.8 Weight, HPM only

See Table B.6.

**Table B.6 — Weights**

Values in kilograms force

Description	Value per unit	Tolerance per unit	Quantity
HPM without weights	19,31	±0,35	1
Cushion pan	8,41	±0,15	1
Back pan	5,94	±0,10	1
Headroom fixture	1,43	±0,03	1
Upper leg	2,11	±0,03	1
Lower leg	0,88	±0,02	1
Shoe	0,54	±0,02	1
HPM with weights (fully loaded)	72,69	±1,20	1
Pelvic weight, plain	3,2	±0,05	4
Pelvic weight, bevelled	3,13	±0,05	2
Thigh weight	2,14	±0,03	6
Back weight	1,79	±0,03	12

## B.9 Support points

Support points are located on the outer surface of the cushion pan (CP) and back pan (BP) contours. See Table B.7 and Figure A.6.

**Table B.7 — Support point locations**

Dimensions in millimetres

Point	Quantity	Distance from H-point		
		$x^a$	$y$	$z^b$
D-Point	1	25,5	0,0	-95,2
CP1	1	0,0	0,0	-98,0
CP2	2	-125,0	±80,0	-78,2
CP3	2	-250,0	±110,0	-69,2
BP1	1	135,1	0,0	35,0
BP2	1	135,1	0,0	175,0
BP3	2	122,7	±90,0	350,0
HPM Tolerance	All support points	±4,0	±4,0	±4,0
<sup>a</sup> Positive $x$ values are rearward, negative values are forward of H-point. <sup>b</sup> Positive $z$ values are above, negative values are below H-point.				

## B.10 Divot point locations

See Table B.8.

Table B.8 — Divot point locations

Divot	Location	HPM description	HPM tolerances
B1	550 mm above the H-Point on the torso line	Located in the screw hole on the top of the back pan T-handle	$\pm 2,0$
B2	330 mm above the H-point 35 mm forward of the torso line (and H-point)	Located along the back pan centreline, in front of the sliding thorax pivot	$\pm 2,0$
H1L H1R	200 mm to the left (H1L) or the right (H1R) of the measured H-point	Located at the ends of the rod where the back pan and cushion pan are joined	$\pm 1,0$
H2L H2R	25 mm inboard of the H1 divots; aligned with H1 divots in $x$ and $z$	Located near the end of the H-point rod in a cutout accessible from above	$\pm 1,0$
C1	275 mm forward of the H-point on the cushion line	Located along the cushion pan centreline, in a hole on top of the push block	$\pm 2,0$
K1L K1R	239 mm to the left (K1L) or right (K1R) of centreline, on the knee pivot axis	Used to define the K-point location. The K1L and K1R provide the $x$ , $z$ coordinates, while K2 provides the $y$ -coordinate	$\pm 2,0$
K2	50 mm forward of the knee pivot centre (K-point)		$\pm 1,0$
S1L S1R	( $x$ ) 81 mm forward of heel of shoe ( $y$ ) 10 mm to either side of the shoe centreline ( $z$ ) 107 mm above bottom of shoe	Located on either side of the ankle pivot (S1L is 10 mm to the left; S1R is 10 mm to the right)	$\pm 2,0 x$
			$\pm 0,5 y$
			$\pm 0,5 z$
S2L S2R	( $x$ ) 81 mm forward of the heel of shoe ( $y$ ) 10 mm to either side of the shoe centreline ( $z$ ) 5 mm above bottom of shoe	Located on top of the sole of the shoe below the ankle pivot (S2L is 10 mm to the left; S2R is 10 mm to the right)	$\pm 2,0 x$
			$\pm 0,5 y$
			$\pm 0,5 z$
S3L S3R	( $x$ ) 175 mm forward of the heel of shoe ( $y$ ) 10 mm to either side of the shoe centreline ( $z$ ) 5 mm above bottom of shoe	Located on top of the sole of the shoe, near the ball of foot (S3L is 10 mm to the left; S3R is 10 mm to the right)	$\pm 2,0 x$
			$\pm 0,5 y$
			$\pm 0,5 z$

## B.11 Muslin cloth

The muslin shall be plain cotton, knitted or non-woven fabric having 18,9 threads/cm<sup>2</sup> and with a surface density of 0,228 kg/m<sup>2</sup>. The cloth should be large enough to prevent the HPM from contacting the seat.

## B.12 Check that HPM is within tolerance specifications

The HPM should be periodically checked to verify it is dimensionally accurate and functioning properly. It should be checked immediately if it appears to be functioning incorrectly, if it appears out of alignment, or if any misuse occurs. Some examples of misuse include:

- a) the HPM is dropped;
- b) the HPM is improperly loaded or assembled — or is improperly unloaded or unassembled — during use;

- c) the HPM is improperly moved or shipped: the HPM should be stored unassembled, with each piece protected and secured to prevent damage, and it is recommended that the weights be stored separately.

A procedure for checking key elements of the HPM is given in Annex C. The HPM should be repaired and rechecked whenever the tolerance specifications given in Annex C cannot be met.

## Annex C (informative)

### HPM field checking procedures

#### C.1 Purpose

This procedure can be used for checking the accuracy of the H-point machine (HPM) to determine if repairs are needed.

#### C.2 Equipment required for checking

##### C.2.1 User-provided equipment

The user should provide the following equipment.

**C.2.1.1 Flat, level surface** (or **surface plate**) approximately 750 mm wide and 1 000 mm long.

**C.2.1.2 Two 90° angle blocks** at least 200 mm wide, one approximately 150 mm high and a second approximately 100 mm high.

**C.2.1.3 Two small C-clamps**, one with 100 mm throat and one with 25 mm throat.

**C.2.1.4 CMM equipment** for taking the measurements.

**C.2.1.5 HPM inclinometer.**

##### C.2.2 Checking fixtures

###### C.2.2.1 Availability and tolerances

Checking fixtures<sup>5)</sup> are described in C.2.2.2 to C.2.2.9 and shown in Figure C.1. Tolerances for surfaces on the fixtures and shims that affect the checking measurements are  $\pm 0,05$  mm.

---

5) The checking fixtures are available from the Society of Automotive Engineers, Warrendale, PA, USA. This information is given for the convenience of users of this document and does not constitute an endorsement by ISO of the product named.

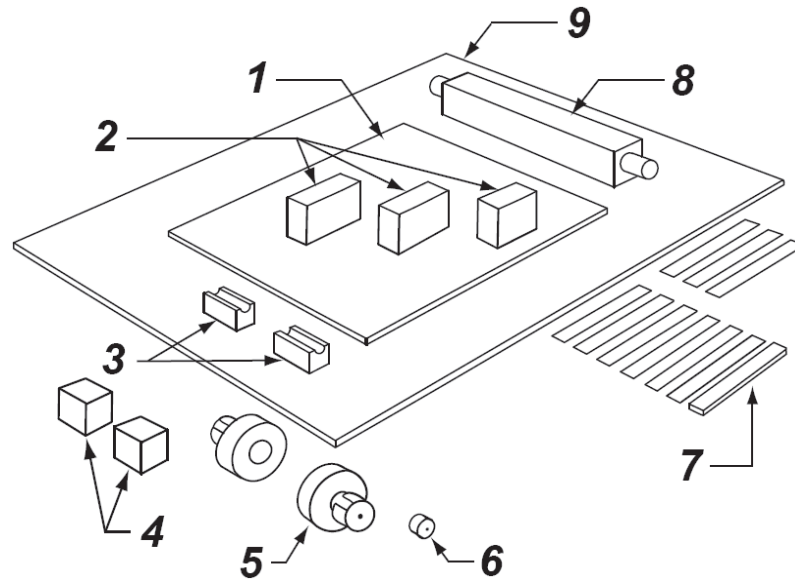

**Key**

- 1 back pan shim
- 2 LSP shims
- 3 knee pivot rod fixtures
- 4 cushion pan shims
- 5 H-point bushings
- 6 knee pivot slot fixture
- 7 back segment checking shims (six of 1 mm, two of 0,5 mm, one of 4 mm)
- 8 thigh rod fixture
- 9 flat level surface

**Figure C.1 — Checking fixtures and shims**

**C.2.2.2 Cushion pan shims**

Two 25 mm × 25 mm × 25 mm gauge blocks are used for levelling the cushion pan.

**C.2.2.3 LSP shims**

Gauge blocks of specified length (73,0 mm, 99,7 mm, and 46,8 mm) that fit between the two inclinometer lands on the back pan articulation rod are used. The three shims are used to position the back pan articulation mechanism at LSP scale readings of 0, +25, and -15.

**C.2.2.4 Back pan shim**

This rectangular shim is used to support the back pan 4 mm above the flat level surface. The shim is approximately 250 mm wide and 400 mm long.

**C.2.2.5 Back pan checking shims**

Two 0,5 mm thick shims, six 1 mm thick shims, and one 4 mm thick shim are used to check pelvic segment clearance to the level surface and back pan gap between lumbar and thoracic segments. The shims are 25 mm wide and approximately 65 mm long.

#### **C.2.2.6 H-point bushings**

Two bushings that fit on each side of the back pan H-point pivot shaft (12 mm diameter holes) provide a divot point for measuring H-point location and slots for inserting the headroom probe H-point forks.

#### **C.2.2.7 Thigh rod fixture**

This fixture provides H-point divots and supports the H-point centre (H1L and H1R, see Figure C.2) on the forks of the thigh segment at a height of 30 mm above the level surface. The diameter of the H-point rods extending from each side of the fixture is 12 mm.

#### **C.2.2.8 Knee pivot rod fixtures**

These fixtures support the knee pivot rod divots (K1L and K1R, see Figure C.2) 30 mm above the level surface. The diameter of the slot in the fixtures is 12,7 mm.

#### **C.2.2.9 Knee pivot slot fixture**

This fixture provides divot points for the knee pivot centre (K1) on the leg segment knee pivot fork. The diameter of the knee pivot slot on the fixture is 12,7 mm.

### **C.2.3 Measurement equipment**

#### **C.2.3.1 CMM**

Points used to determine the distance measurements that are shown in Table C.1 and described in C.5 should be taken with a CMM. Angular measurements on the inclinometer lands are taken with both the inclinometer and a CMM. When CMM equipment is used to check angle measurements on the inclinometer lands, the digitized points taken on the lands should be separated by the length of the inclinometer (or greater) as shown in Figure C.3.

The  $x$ -,  $y$ -, and  $z$ -axis orientations to be used for recording CMM data are shown in Figures C.4, C.6, C.7, C.8 and C.9. This provides a direction convention for both linear and angular measurements. Establish and maintain this axis orientation on the flat level surface used to position the HPM components. A positive angle is clockwise as viewed from the left side of the components. This angle convention is consistent with positive cushion angle and torso angle definitions.

#### **C.2.3.2 Electronic level (HPM inclinometer)**

Prior to checking the HPM place the inclinometer parallel to the  $x$ -axis on the flat level surface used for testing and set the inclinometer reading to zero using the alt zero button. It is desirable to re-zero the inclinometer prior to each measurement taken. Use the information provided by the inclinometer manufacturer to check accuracy of the inclinometer. The inclinometer should be regularly checked and certified per manufacturer specifications.

### **C.3 HPM measurement locations**

Most measurements specified in the checking procedures are taken to the HPM divot points and inclinometer lands shown in Figures C.2 and C.3. Divot points K2, S2, S3 and inclinometer lands on the bottom of the shoe are not used in the calibration procedure.

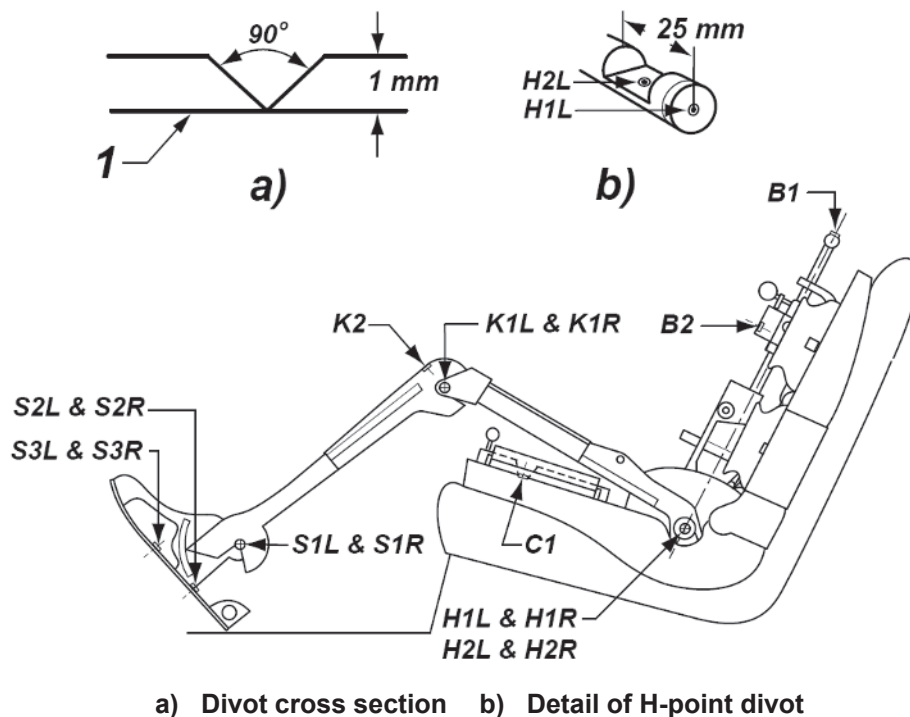

**Key**

1 reference surface

**Figure C.2 — HPM reference points (divot points)**

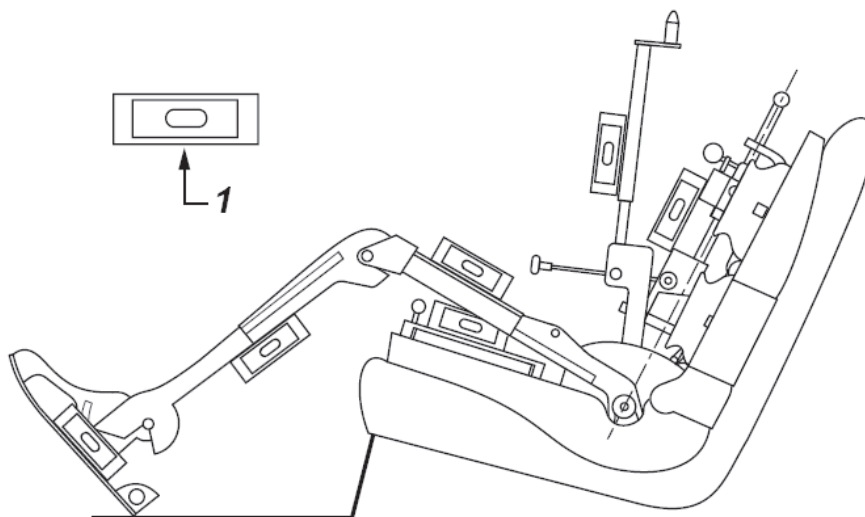

**Key**

1 electronic inclinometer

**Figure C.3 — HPM reference surfaces (inclinometer lands)**

## C.4 Summary of measurements and tolerances

Measurements and tolerances used to check the HPM are summarized in Table C.1. If the tolerance specifications cannot be achieved for any measurement, the HPM should be repaired and rechecked.

**Table C.1 — HPM checking dimensions and tolerances**

Section	Description	Measurement	Tolerance
<b>Cushion pan</b>			
C.5.2.2.1	Cushion angle on inclinometer land using inclinometer	0°	±1°
C.5.2.2.1	Cushion angle on inclinometer land using CMM	0°	±1°
C.5.2.2.2	Cushion angle (using C1, H1L, and H1R divot points)	0°	±1°
C.5.2.2.3	Differences in cushion angle measurements (inclinometer/divots)	0°	1°
C.5.2.2.3	Differences in cushion angle measurements (CMM/divots)	0°	1°
C.5.2.3	Bubble level reading	Between marks	
C.5.2.3	H1L and H1R heights from level surface	98 mm	±2 mm
C.5.2.3	Difference between H1L and H1R heights	0 mm	2 mm
C.5.2.3	Difference between H1L and H2L, and H1R and H2R in <i>x</i> and <i>z</i>	0 mm	1 mm
C.5.2.3	Difference between H2L <i>y</i> -coordinate and H2R <i>y</i> -coordinate	0 mm	1 mm
C.5.2.4	C1 divot point to H-point	275 mm	±2 mm
C.5.2.4	C1 divot point above the level surface	98 mm	±2 mm
C.5.2.5	H-point to back of cushion pan	133 mm	±2 mm
C.5.2.6	Cushion pan alignment (difference between C1 to H1L and C1 to H1R)	0 mm	2 mm
<b>Back pan</b>			
C.5.3.2	LSP at -15 (on LSP scale)	-15	±1 unit
C.5.3.3	LSP at +25 (on LSP scale)	+25	±1 unit
C.5.3.4	LSP at zero (on LSP scale)	0	±1 unit
C.5.4.2	Lumbar or thoracic segment offset from level surface	0 mm	1 mm
C.5.4.2	Segment that is offset (lumbar or thoracic)		
C.5.4.3	Pelvic segment offset from level surface	4 mm	±2 mm
C.5.4.4.1	Torso angle on inclinometer land using inclinometer	0°	±1°
C.5.4.4.1	Torso angle on inclinometer land using CMM	0°	±1°
C.5.4.4.2	Torso angle (using B1 and H-point bushing divot points)	0°	±1°
C.5.4.4.3	Differences in torso angle (inclinometer versus divots)	0°	1°
C.5.4.4.3	Differences in torso angle (CMM versus divots)	0°	1°
C.5.4.5	H-point bushing divot on back pan (each side) from level surface	139 mm	±2 mm
C.5.4.5	Difference in H-point bushing divot height at each side	0 mm	2 mm
C.5.4.6	B1 divot point height above the level surface	139 mm	±2 mm
C.5.4.6	B1 divot point to H-point	550 mm	±2 mm
C.5.4.7	B2 divot point to H-point	330 mm	±2 mm



Table C.1 (continued)

Section	Description	Measurement	Tolerance
<b>Headroom probe</b>			
C.5.5.2	Torso angle on headroom probe using inclinometer	0°	±1°
C.5.5.2	Torso angle on headroom probe using CMM	0°	±1°
C.5.5.2.2	Difference in torso angle measures using headroom probe (inclinometer versus CMM)	0°	1°
C.5.5.2.3	All differences in torso angle measurements (including C.5.3.3.1, C.5.3.3.2, and C.5.3.3.3) — six difference measures	0°	1°
C.5.5.3	Distance from tip of headroom probe to H-point line (1 000 mm reading on headroom scale)	898 mm	±1 mm
C.5.5.4	Distance in top view from tip of headroom probe, perpendicular to a line extended from the mid H-point through the B1 divot	0 mm	4 mm
<b>Thigh</b>			
C.5.6.2	Thigh angle on thigh angle land (inclinometer and CMM) — left side	0°	±1°
C.5.6.2	Thigh angle on thigh angle land (inclinometer and CMM) — right side	0°	±1°
C.5.6.3	Thigh segment flatness (maximum angle difference between sides)	0°	1°
C.5.6.4	K1L on the thigh segment to divot on the thigh rod fixture, measured parallel to <i>x</i> -axis (thigh length left side)	456 mm	±2 mm
C.5.6.4	K1R on the thigh segment to divot on the thigh rod fixture, measured parallel to <i>x</i> -axis (thigh length right side)	456 mm	±2 mm
C.5.6.4	Difference between thigh lengths (each side)	0 mm	2 mm
<b>Lower leg</b>			
C.5.7.2	Back of leg when ankle angle is 96,5° (on shoe)	90°	±1°
C.5.7.3	K1 to S1 (knee pivot to ankle pivot)	459 mm	±2 mm
C.5.7.4	K1 to bottom of shoe (knee pivot to level surface)	566 mm	±2 mm
C.5.7.5	Check knee angle scale	90°	±1°

## C.5 Checking procedures

### C.5.1 Surface

HPM components and fixtures shall be placed on a flat level surface (surface plate) when using the measurement procedures described in this clause.

### C.5.2 Cushion pan

#### C.5.2.1 Setup

Place the cushion pan on the level surface with the 25 mm gauge blocks at the front edge of the pan centred under each thigh (see Figure C.4). Load a pelvic weight at the inboard location on each side and a thigh weight at each side on the cushion pan. Use H1L and H1R *x*-coordinates to align the cushion pan to the *y*-axis. Place the angle block against the centre of the rear exterior surface of the cushion pan.

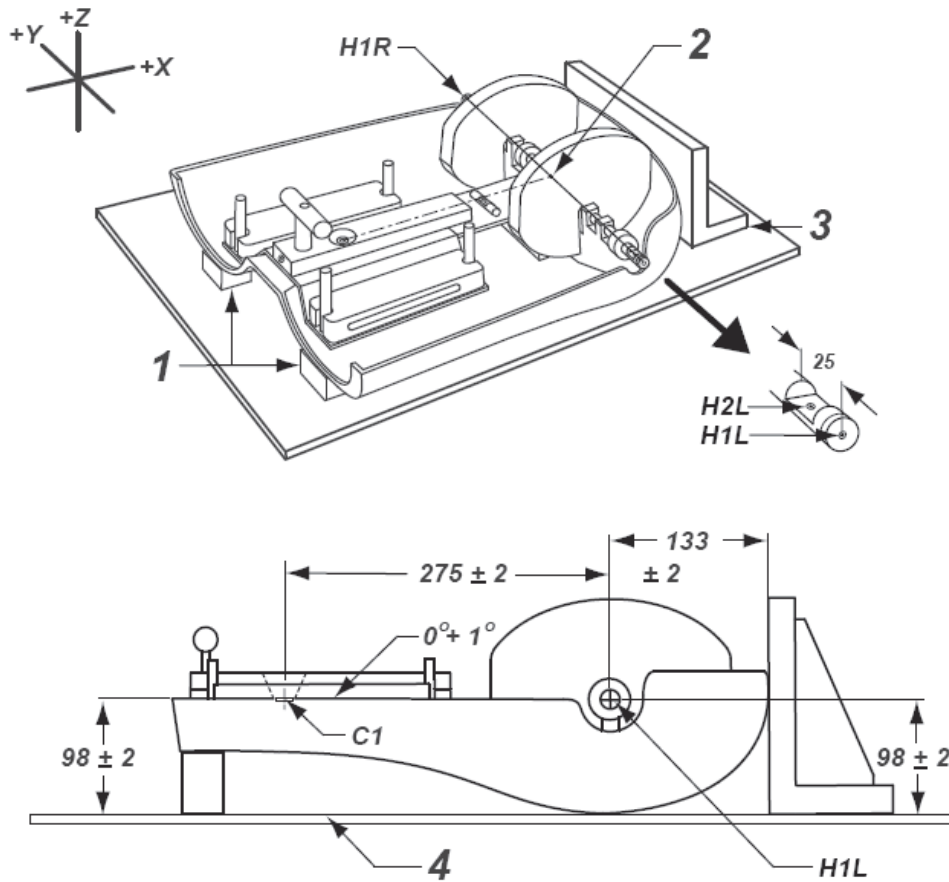

**Key**

- 1 cushion pan shims
- 2 H-point is the midpoint between H1L and H1R
- 3 90° angle block
- 4 flat level surface

**Figure C.4 — Cushion pan checking procedure**

**C.5.2.2 Check cushion angle (2 methods)**

**C.5.2.2.1 Method 1: Use the cushion angle inclinometer land**

Cushion angle measured from the inclinometer land surface should be  $0^\circ \pm 1^\circ$  using either CMM or the inclinometer.

**C.5.2.2.2 Method 2: Use divot points to define the cushion line**

Locate the H-point at the midpoint between H1L and H1R. The cushion line extends from H-point through the C1 divot. The cushion angle measured from C1 to the H-point should be  $0^\circ \pm 1^\circ$ .

**C.5.2.2.3 Check cushion angle difference**

Cushion angle measured by either method 1 or method 2 should not differ by more than  $1^\circ$ .

### **C.5.2.3 Check H-point height from level surface**

H1L and H1R divots should be  $98 \text{ mm} \pm 2 \text{ mm}$  above the level surface. The difference between H1L and H1R heights at each side should be no more than 4 mm. The transverse bubble level should read level. (The bubble should be within the level indicator lines.)

The horizontal and vertical location of H2L and H2R should be within 1 mm of H1L and H1R, respectively. The absolute value of the  $y$ -coordinates of H2L and H2R should not differ by more than 1 mm.

### **C.5.2.4 Check C1 divot**

The distance from the C1 divot to the H-point (established in C.5.2.2.2) should be  $275 \text{ mm} \pm 2 \text{ mm}$ . The C1 divot should be  $98 \text{ mm} \pm 2 \text{ mm}$  above the flat level surface.

### **C.5.2.5 Check H-point to back of cushion pan**

The horizontal distance from the H-point (established in C.5.2.2.2) to the angle block at the back of the cushion pan should be  $133 \text{ mm} \pm 2 \text{ mm}$  measured perpendicular to the line between H1L and H1R.

### **C.5.2.6 Check cushion pan alignment**

The difference between the diagonal distances C1 to H1L and C1 to H1R should not be more than 2 mm.

## **C.5.3 LSP scale checks at $-15$ , $+25$ , and $0$**

### **C.5.3.1 Setup**

See Figure C.5. LSP shims are used on the back pan to set the linkage geometry at the three specified LSP checking values. Rotating the torso articulation locking lever inward releases the articulation and allows the LSP shim to be fitted between the linkage segments. Rotating the torso locking lever outward locks the linkage geometry and tightens the LSP shim securely in place.

Lay the back pan on a flat surface. Unlock the back pan articulation and move the back pan linkage so that the gap between the linkage segments is large enough to accept the LSP shim to be inserted. Be sure to place the shim between flat surfaces. Read the left side of the LSP scale to the nearest 0,5 mm.

### **C.5.3.2 Check LSP $-15$**

Insert the  $-15$  LSP shim and lock the torso. The LSP scale should read  $-15 \pm 1$ .

### **C.5.3.3 Check LSP $+25$**

Remove the  $-15$  shim. Insert the  $+25$  shim and lock the torso. The LSP scale should read  $+25 \pm 1$ .

### **C.5.3.4 Check LSP $0$**

Remove the  $+25$  shim. Insert the  $0$  shim and lock the torso. The LSP scale should read  $0 \pm 1$ .

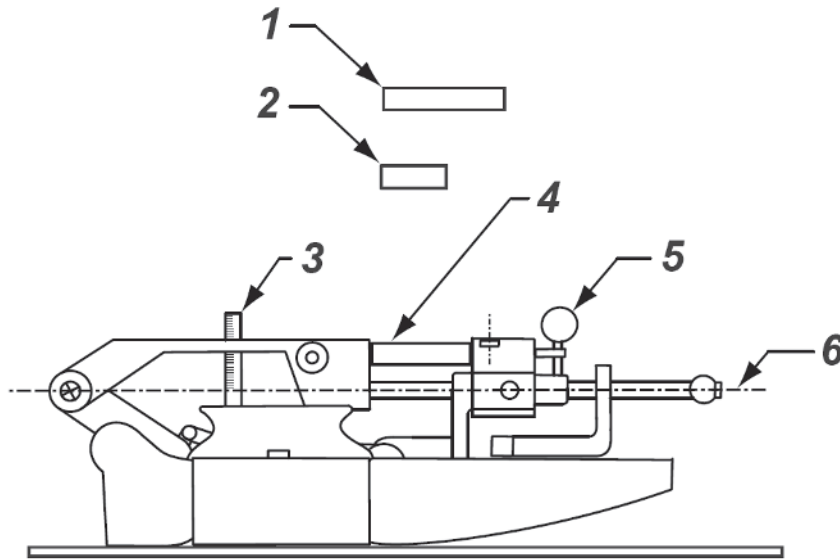

**Key**

- 1 LSP +25 shim
- 2 LSP -15 shim
- 3 LSP scale
- 4 LSP 0 shim
- 5 torso articulation locking lever
- 6 torso line

**Figure C.5 — LSP shim installation**

**C.5.4 Back pan**

**C.5.4.1 Setup**

See Figure C.6. Retain the LSP zero shim between the linkage segments. Place the back pan shim on the flat level surface with the shorter side against an angle block that has been aligned with the  $y$ -axis. Lay the back pan on the back pan shim with the end of the thoracic panel against the angle block. Insert the H-point bushings at each side of the H-point pivot shaft on the back pan. Install four back pan weights, two each on the inboard ends of the lumbar panel weight racks.

Align the back pan and components so that the torso line on the back pan is parallel to the  $x$ -axis. Use the  $y$ -coordinate of B1 and the midpoint of the  $y$ -coordinates on the H-point bushing left and right divots. The midpoint may be marked on tape placed on the flat bracket between the H-point bushings to facilitate alignment. To stabilize the back pan, place an angle block against the H-point bushings.

Dimensions in millimetres

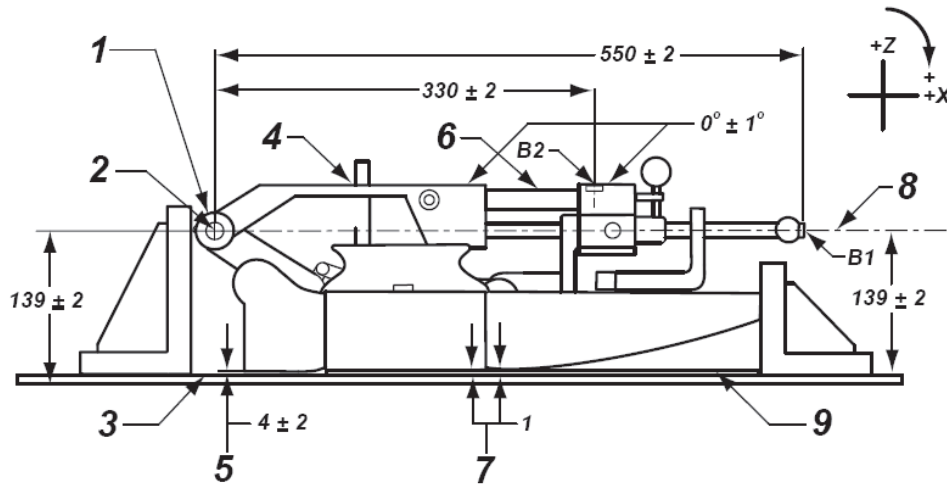

**Key**

- 1 H-point bushings with divots
- 2 H-point is the midpoint between divots
- 3 flat level surface
- 4 LSP scale
- 5 clearance at edge of pelvis segment
- 6 LSP 0 shim
- 7 maximum gap at either location
- 8 torso line
- 9 back pan shim

**Figure C.6 — Back pan checking procedure**

**C.5.4.2 Check for offset of back pan segments**

With the back pan in place as described in C.5.4, visually inspect the surface contact of the lumbar and thoracic segments on the back pan shim near the longitudinal centreline of the back pan. The thoracic and lumbar segment surfaces should be in contact with the flat surface of the shim. Near the gap between the two segments, neither segment should be more than 1 mm above to the back segment checking shim. Use the 0,5 mm and 1 mm back segment shims as checking gauges. Record which segment, if any, is offset from the level surface. Leave the shim(s) in place to stabilize the back pan for the remainder of the back pan measurements.

**C.5.4.3 Check pelvic segment offset from flat surface**

The lower edge of the pelvic segment at or near the centreline of the back pan should be  $4 \text{ mm} \pm 2 \text{ mm}$  from the flat surface. Use the back segment checking shims to measure the clearance to the nearest 0,5 mm. Leave the shims in place to stabilize the back pan for the remainder of the back pan measurements.

**C.5.4.4 Check torso angle (two methods)**

**C.5.4.4.1 Method 1: Use the torso angle inclinometer land**

Torso angle measured along the inclinometer land surface should be  $0^\circ \pm 1^\circ$  using either CMM or the inclinometer (relative to the level surface).

#### **C.5.4.4.2 Method 2: Use divot points to establish the torso line**

Establish the H-point at the midpoint between the left and right side divot points on the H-point bushing fixtures. The torso line extends from the H-point through the B1 divot. Torso angle measured between B1 and the H-point should be  $0^\circ \pm 1^\circ$  (relative to the level surface).

#### **C.5.4.4.3 Check torso angle difference**

Torso angle measured by either method 1 or method 2 should not differ by more than  $1^\circ$ .

#### **C.5.4.5 Check H-point distance from level surface**

The H-point divots on the H-point bushing fixtures should be  $139 \text{ mm} \pm 2 \text{ mm}$  above the level surface. The height difference between sides should be no more than 1 mm.

#### **C.5.4.6 Check B1 divot**

The B1 divot should be  $139 \text{ mm} \pm 2 \text{ mm}$  above the level surface. The B1 divot should also be  $550 \text{ mm} \pm 2 \text{ mm}$  measured along the torso line to the H-point (established in C.5.4.4.2).

#### **C.5.4.7 Check B2 divot**

The B2 divot should be  $330 \text{ mm} \pm 2 \text{ mm}$  measured parallel to the torso line to a vertical line from the H-point (established in C.5.4.4.2)

### **C.5.5 Headroom probe**

#### **C.5.5.1 Setup**

See Figure C.7. Continue with the setup in C.5.4. Extend the headroom probe to a scale reading of 1 000 mm to expose the land surface. Insert the forks of the headroom probe in the slots on the H-point bushings. Make sure the angle adjusting screw is locked in place on the back pan, the headroom probe is resting snugly against the back pan, and the forks are firmly seated against the H-point bushings. The flat area on the H-point bushings should be positioned so that the forks are seated against the bushings. Use a C-clamp across the sides of the probe to hold the forks against the inner flanges on the H-point bushings.

Dimensions in millimetres

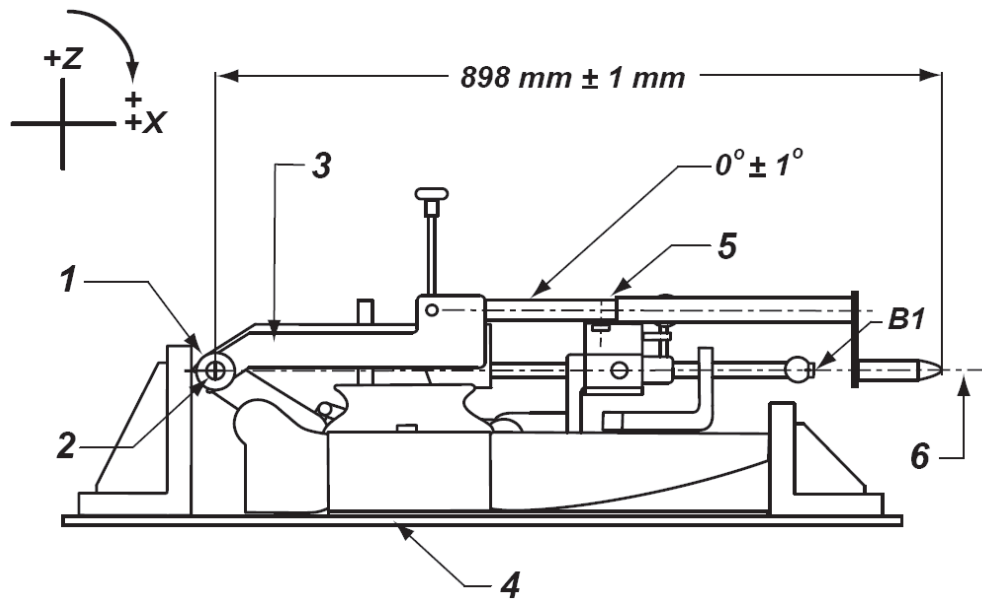

**Key**

- 1 H-point bushings with divots
- 2 H-point is the midpoint between divots
- 3 clamp application point
- 4 flat level surface
- 5 effective headroom scale reading, 1 000 mm
- 6 torso line

**Figure C.7 — Headroom probe checking procedure**

**C.5.5.2 Check torso angle on the headroom probe**

**C.5.5.2.1 Measurement**

The torso angle measured on the inclinometer land of the headroom probe should be  $0^\circ \pm 1^\circ$  using either CMM or the inclinometer (relative to the level surface).

**C.5.5.2.2 Angular difference: CMM to inclinometer**

The angle measured with CMM and the inclinometer should not differ by more than  $1^\circ$ .

**C.5.5.2.3 Angular difference: probe land to back land**

Torso angle measured in C.5.5.2 should not differ by more than  $1^\circ$  from the torso angle measurements taken in C.5.4.4.

**C.5.5.3 Check headroom scale**

With the headroom probe scale reading 1 000 mm, the distance from the tip of the head room probe to the H-point (established in C.5.4.4.2) should be  $898 \text{ mm} \pm 1 \text{ mm}$ . Ensure that the clamp keeps the forks of the headroom probe firmly against the H-point bushings.

### C.5.5.4 Check headroom probe tip alignment

Extend the torso line originating at the H-point (established in C.5.4.4.2) through the B1 divot and beyond the tip of the headroom probe. The perpendicular distance measured in top view ( $xy$ -plane) from the torso line to the tip of the headroom probe should be no more than 4 mm.

## C.5.6 Thigh segment

### C.5.6.1 Setup

See Figure C.8. Pin the thigh segment at the SgRP length and place the segment on a level surface with the thigh rod fixture inserted in the H-point forks and the knee pivot rod resting on the knee pivot rod fixtures. Slide each knee pivot rod fixture to the ends of the knee pivot rod. Use the  $x$ -coordinates of K1L and K1R to align the thigh segment to the  $y$ -axis.

Dimensions in millimetres

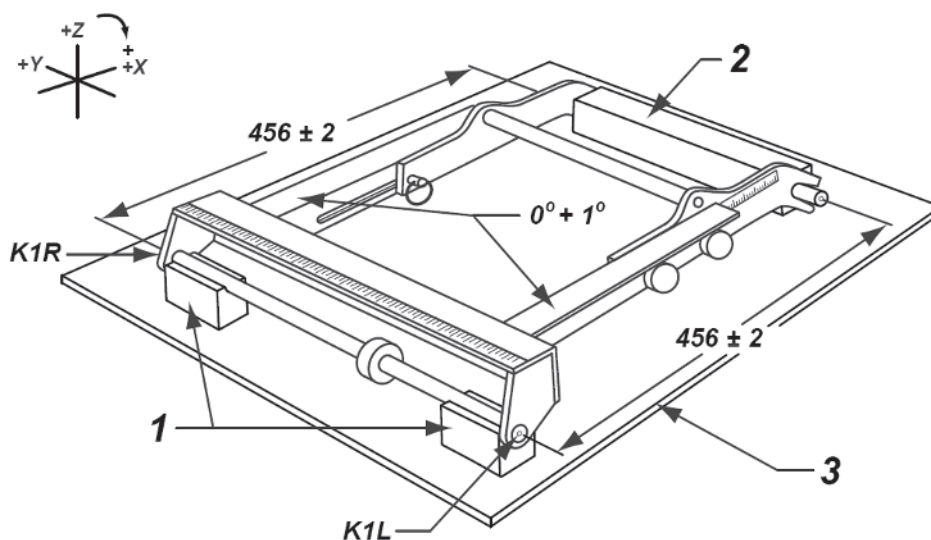

#### Key

- 1 knee pivot rod fixtures
- 2 thigh rod fixture with divots
- 3 flat level surface

Figure C.8 — Thigh segment checking procedure

### C.5.6.2 Check thigh angle

The thigh angle measured from each inclinometer land should be  $0^\circ \pm 1^\circ$ . Both the inclinometer and the CMM should be used.

### C.5.6.3 Check thigh segment flatness

The thigh segment should rest against the fixtures at all four corners. The difference between thigh angles at each side should be no more than  $1^\circ$ .



#### **C.5.6.4 Check thigh length**

The distance between the  $x$ -coordinates of the knee pivot centre and the divot at the end of thigh rod fixture should be  $456 \text{ mm} \pm 2 \text{ mm}$ . Measure each side. The length difference between left and right sides should not exceed 2 mm.

### **C.5.7 Leg**

#### **C.5.7.1 Setup**

See Figure C.9. Pin the leg at SgRP length. Stand the lower leg with the shoe attached on the level surface. Insert the knee pivot slot fixture in the knee pivot slot. Clamp the lower leg so the ankle angle scale maintains a reading of  $96,5^\circ$ . HPM thigh weights (not shown in the figure) may be placed on each side of the base of the shoe to help stabilize the leg assembly.

#### **C.5.7.2 Check ankle angle**

The back of the leg should be  $90^\circ \pm 1^\circ$ .

#### **C.5.7.3 Check knee pivot to ankle pivot length**

The height from the knee pivot to the ankle pivot (S1 divot) should be  $459 \text{ mm} \pm 2 \text{ mm}$ . This measurement may be taken on either side of the leg.

#### **C.5.7.4 Check knee pivot to flat level surface (bottom of shoe)**

The height from knee pivot to the bottom of shoe should be  $566 \text{ mm} \pm 2 \text{ mm}$ .

Dimensions in millimetres

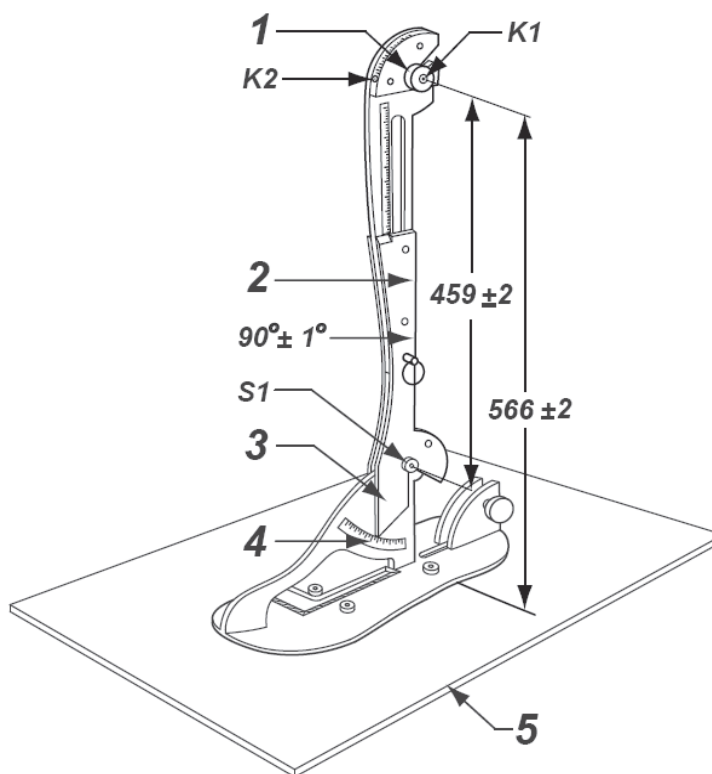

Key

- 1 knee pivot slot fixture with divots
- 2 back of leg
- 3 apply clamp here with ankle angle at  $96,5^\circ$
- 4 ankle angle
- 5 flat level surface

Figure C.9 — Leg length and ankle angle checking procedure

#### C.5.7.5 Check knee angle scale

Stand the thigh segment on its side supported with one of the knee pivot rod fixtures. Add three 1 mm shims near the knee pivot to stabilize the set up. Attach the lower leg and lock in place using the knee pivot locking bushing. Rotate the back of the lower leg to a  $90^\circ$  angle with the bottom of the thigh segment using angle blocks to maintain the position (see Figure C.10).

The knee angle scale should read  $90^\circ \pm 1^\circ$ .

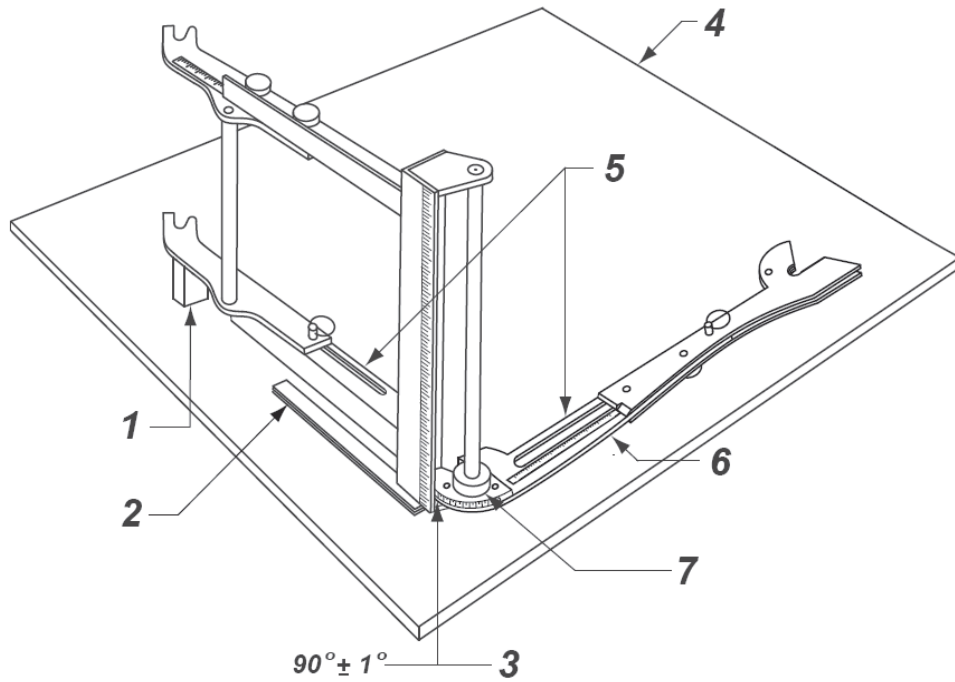

**Key**

- 1 thigh segment supported by one of the knee pivot rod fixtures
- 2 three 1 mm shims
- 3 knee angle value and scale
- 4 flat level surface
- 5 back of lower leg positioned relative to bottom of thigh segment (using angle blocks)
- 6 lower leg rests on locking screw knobs
- 7 lower leg locked to knee pivot rod with locking bushing

**Figure C.10 — Knee angle scale checking procedure**

## Annex D (informative)

### H-point design (HPD) tool description

#### D.1 H-point design tool (HPD)

Application of the HPD tool is described in SAE J4004. The HPD tool can be used in conjunction with the HPM to make some of the HPM measurements in CAD (see SAE J4003).

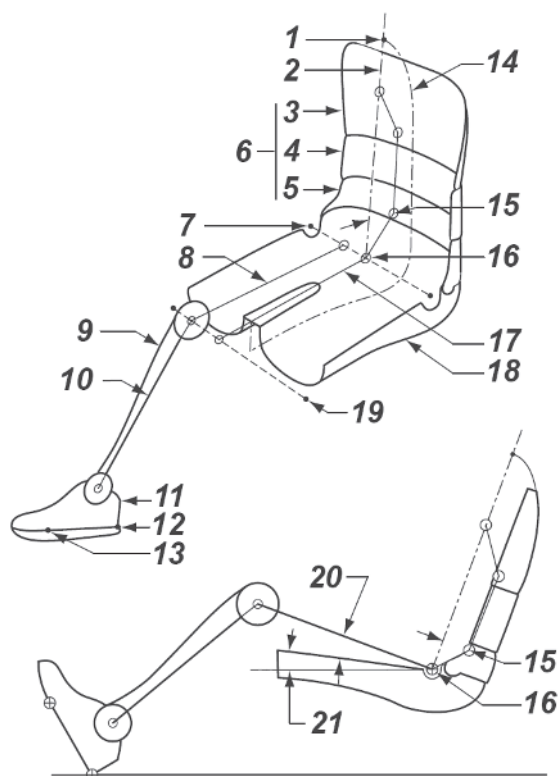

#### Key

1	shoulder reference point	8	thigh line	15	LSP
2	torso line	9	lower leg	16	H-point
3	thoracic segment	10	leg line	17	cushion line
4	lumbar segment	11	shoe	18	cushion pan
5	pelvic segment	12	HOS	19	knee pivot line (lateral range of lower leg)
6	back pan	13	BOF	20	thigh angle
7	H-point line	14	2-D template profile	21	cushion angle

**Figure D.1 — H-point design tool (HPD) — Elements are common to the H-point machine (HPM-II) except for parts of the 2-D profile**

## D.2 File format

Currently, the HPD data file<sup>6)</sup> is only available in the IGES format. The IGES file can be used as a template for creating native geometry within the resident CAD system. (This is recommended.) Specifications and tolerances for the HPD are given in SAE J4004.

## D.3 Datum lines

In addition to the reference lines discussed in A.3.4, other datum lines are provided to assist the user (see Figure D.2):

- a) lateral centreline of shoe;
- b) lateral centreline of manikin (through back pan and cushion pan);
- c) effective headroom line;
- d) section curves cut through support points;
- e) additional section curves cut through the cushion and back pans.

The additional section curves are provided to convey the size and shape of complex torso geometry. This is a quality assurance measure, and provides an effective way of validating geometry across CAD systems.

At present the user has to add the kinematics for the back pan to the CAD file. The user also has to add the 2-D profile to the CAD data in order to develop the HPD CAD tool shown in Figure D.1. In the future, SAE may provide the HPD CAD tool as it appears in Figure D.1, possibly including the kinematics.

---

6) The HPD data file is available from the Society of Automotive Engineers, Warrendale, PA, USA. This information is given for the convenience of users of this document and does not constitute an endorsement by ISO of the product named.

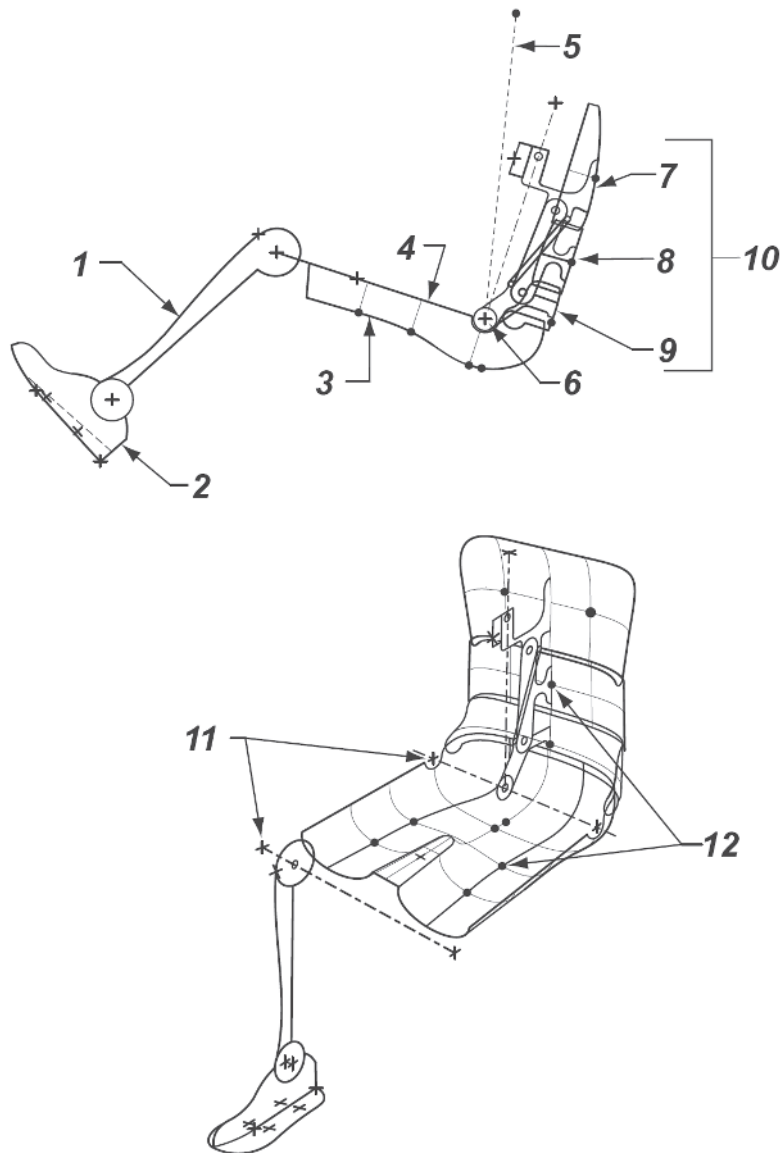

**Key**

- 1 lower leg
- 2 shoe
- 3 cushion pan
- 4 thigh
- 5 effective headroom line
- 6 H-point
- 7 thoracic segment
- 8 lumbar segment
- 9 pelvic segment
- 10 back pan
- 11 divot points (+) on the HPM
- 12 support points on the cushion and back pans

**Figure D.2 — HPD CAD data provided by SAE**

## Bibliography

- [1] ISO 3833, *Road vehicles — Types — Terms and definitions*
- [2] ISO 6549, *Road vehicles — Procedure for H- and R-point determination*
- [3] SAE J4003, *H-point machine (HPM-II) — Procedure for H-point determination — Benchmarking vehicle seats*
- [4] SAE J4004, *Positioning the H-point design tool — Seating reference point and seat track length*
- [5] MANARY, M.A., FLANNAGAN, C.A.C., REED, M.P., SCHNEIDER, L.W. *Human subject testing in support of ASPECT*. SAE Technical Paper 1999-01-0960
- [6] SCHNEIDER, L.W., REED, M.P., ROE, R.W., MANARY, M.A., FLANNAGAN, C.A.C., HUBBARD, R.P., RUPP, G.L. *ASPECT: The next-generation H-Point machine and related vehicle and seat design and measurement tools*. SAE Technical Paper 1999-01-0962
- [7] REED, M.P., ROE, R.W., SCHNEIDER, L.W. *Design and development of the ASPECT manikin*. SAE Technical Paper 1999-01-0963
- [8] REID BUSH, T., GREGG, S.J., HUBBARD, R.P. *Measuring and modeling support forces of people to assist in the development of the ASPECT manikin weighting*. SAE Technical Paper 1999-01-0961
- [9] ROE, R.W., REED, M.P., SCHNEIDER, L.W. *ASPECT manikin applications and measurements for design, audit, and benchmarking*. SAE Technical Paper 1999-01-0965
- [10] REED, M.P., ROE, R.W., MANARY, M.A., FLANNAGAN, C.A.C., SCHNEIDER, L.W. *New concepts in vehicle interior design using ASPECT*. SAE Technical Paper 1999-01-0967
- [11] FLANNAGAN, C.A.C. *Reproducibility and repeatability of the SAE J4002 and J826 H-point machines*. SAE Technical Paper 2005-01-1010







# British Standards Institution (BSI)

BSI is the independent national body responsible for preparing British Standards and other standards-related publications, information and services.

It presents the UK view on standards in Europe and at the international level.

It is incorporated by Royal Charter.

## Revisions

British Standards are updated by amendment or revision. Users of British Standards should make sure that they possess the latest amendments or editions.

It is the constant aim of BSI to improve the quality of our products and services. We would be grateful if anyone finding an inaccuracy or ambiguity while using this British Standard would inform the Secretary of the technical committee responsible, the identity of which can be found on the inside front cover.

**Tel: +44 (0)20 8996 9001 Fax: +44 (0)20 8996 7001**

BSI offers Members an individual updating service called PLUS which ensures that subscribers automatically receive the latest editions of standards.

**Tel: +44 (0)20 8996 7669 Fax: +44 (0)20 8996 7001**

**Email: [plus@bsigroup.com](mailto:plus@bsigroup.com)**

## Buying standards

You may buy PDF and hard copy versions of standards directly using a credit card from the BSI Shop on the website [www.bsigroup.com/shop](http://www.bsigroup.com/shop). In addition all orders for BSI, international and foreign standards publications can be addressed to BSI Customer Services.

**Tel: +44 (0)20 8996 9001 Fax: +44 (0)20 8996 7001**

**Email: [orders@bsigroup.com](mailto:orders@bsigroup.com)**

In response to orders for international standards, it is BSI policy to supply the BSI implementation of those that have been published as British Standards, unless otherwise requested.

## Information on standards

BSI provides a wide range of information on national, European and international standards through its Knowledge Centre.

**Tel: +44 (0)20 8996 7004 Fax: +44 (0)20 8996 7005**

**Email: [knowledgecentre@bsigroup.com](mailto:knowledgecentre@bsigroup.com)**

Various BSI electronic information services are also available which give details on all its products and services.

**Tel: +44 (0)20 8996 7111 Fax: +44 (0)20 8996 7048**

**Email: [info@bsigroup.com](mailto:info@bsigroup.com)**

BSI Subscribing Members are kept up to date with standards developments and receive substantial discounts on the purchase price of standards. For details of these and other benefits contact Membership Administration.

**Tel: +44 (0)20 8996 7002 Fax: +44 (0)20 8996 7001**

**Email: [membership@bsigroup.com](mailto:membership@bsigroup.com)**

Information regarding online access to British Standards via British Standards Online can be found at [www.bsigroup.com/BSOL](http://www.bsigroup.com/BSOL)

Further information about BSI is available on the BSI website at [www.bsigroup.com/standards](http://www.bsigroup.com/standards)

## Copyright

Copyright subsists in all BSI publications. BSI also holds the copyright, in the UK, of the publications of the international standardization bodies. Except as permitted under the Copyright, Designs and Patents Act 1988 no extract may be reproduced, stored in a retrieval system or transmitted in any form or by any means – electronic, photocopying, recording or otherwise – without prior written permission from BSI. This does not preclude the free use, in the course of implementing the standard of necessary details such as symbols, and size, type or grade designations. If these details are to be used for any other purpose than implementation then the prior written permission of BSI must be obtained. Details and advice can be obtained from the Copyright & Licensing Manager.

**Tel: +44 (0)20 8996 7070**

**Email: [copyright@bsigroup.com](mailto:copyright@bsigroup.com)**

## BSI Group Headquarters

389 Chiswick High Road London W4 4AL UK

Tel +44 (0)20 8996 9001

Fax +44 (0)20 8996 7001

[www.bsigroup.com/standards](http://www.bsigroup.com/standards)