

BS ISO 19072-2:2013



BSI Standards Publication

Road vehicles — Connection interface for pyrotechnic devices, two-way and three-way connections

Part 2: Test methods and general performance requirements

bsi.

...making excellence a habit.™

National foreword

This British Standard is the UK implementation of ISO 19072-2:2013. It supersedes BS ISO 19072-2:2007 which is withdrawn.

The UK participation in its preparation was entrusted to Technical Committee AUE/16, Electrical and electronic equipment.

A list of organizations represented on this committee can be obtained on request to its secretary.

This publication does not purport to include all the necessary provisions of a contract. Users are responsible for its correct application.

© The British Standards Institution 2013. Published by BSI Standards Limited 2013

ISBN 978 0 580 79265 6

ICS 43.040.10

Compliance with a British Standard cannot confer immunity from legal obligations.

This British Standard was published under the authority of the Standards Policy and Strategy Committee on 30 September 2013.

Amendments issued since publication

Date	Text affected
------	---------------

INTERNATIONAL
STANDARD

ISO
19072-2

Second edition
2013-09-01

**Road vehicles — Connection interface
for pyrotechnic devices, two-way and
three-way connections —**

Part 2:
**Test methods and general
performance requirements**

*Véhicules routiers — Interface de raccordement pour dispositifs
pyrotechniques, deux voies et trois voies —*

Partie 2: Méthodes d'essai et exigences des performances générales



Reference number
ISO 19072-2:2013(E)

© ISO 2013



COPYRIGHT PROTECTED DOCUMENT

© ISO 2013

All rights reserved. Unless otherwise specified, no part of this publication may be reproduced or utilized otherwise in any form or by any means, electronic or mechanical, including photocopying, or posting on the internet or an intranet, without prior written permission. Permission can be requested from either ISO at the address below or ISO's member body in the country of the requester.

ISO copyright office
Case postale 56 • CH-1211 Geneva 20
Tel. + 41 22 749 01 11
Fax + 41 22 749 09 47
E-mail copyright@iso.org
Web www.iso.org

Published in Switzerland

Contents

Page

Foreword	iv
Introduction	v
1 Scope	1
2 Normative references	1
3 Terms and definitions	1
4 Functional characteristics of mated connectors	2
4.1 General.....	2
4.2 Visual examination.....	2
4.3 Mating and unmating.....	2
4.4 Resistance to tensile and compressive force between the connector and squib holder equipped with initiator and retainer.....	3
4.5 Mechanical strength of the retainer in the squib holder.....	5
4.6 Combination of temperature/humidity/vibration.....	5
4.7 Coding.....	8
4.8 Polarisation.....	8
4.9 Contact resistance (voltage drop), millivolt test.....	8
4.10 Insulation resistance.....	10
4.11 Withstand voltage.....	10
4.12 Thermal ageing.....	10
4.13 Opening and closing of the short-circuit.....	10
4.14 Short-circuit resistance.....	11
4.15 Rapid change of temperature (thermal shock).....	12
4.16 Chemical fluids.....	12
5 Test sequences	12
Annex A (normative) Sealed variant of the pyrotechnic device/initiator harness connector assembly	14
Annex B (normative) Two-way (without ground) variant of the pyrotechnic device/initiator harness connector assembly	16
Annex C (normative) Variant without retainer of the pyrotechnic device/initiator harness connector assembly	18
Bibliography	19

Foreword

ISO (the International Organization for Standardization) is a worldwide federation of national standards bodies (ISO member bodies). The work of preparing International Standards is normally carried out through ISO technical committees. Each member body interested in a subject for which a technical committee has been established has the right to be represented on that committee. International organizations, governmental and non-governmental, in liaison with ISO, also take part in the work. ISO collaborates closely with the International Electrotechnical Commission (IEC) on all matters of electrotechnical standardization.

The procedures used to develop this document and those intended for its further maintenance are described in the ISO/IEC Directives, Part 1. In particular the different approval criteria needed for the different types of ISO documents should be noted. This document was drafted in accordance with the editorial rules of the ISO/IEC Directives, Part 2. www.iso.org/directives

Attention is drawn to the possibility that some of the elements of this document may be the subject of patent rights. ISO shall not be held responsible for identifying any or all such patent rights. Details of any patent rights identified during the development of the document will be in the Introduction and/or on the ISO list of patent declarations received. www.iso.org/patents

Any trade name used in this document is information given for the convenience of users and does not constitute an endorsement.

The committee responsible for this document is ISO/TC 22, *Road vehicles*, Subcommittee SC 3, *Electrical and electronic equipment*.

For an explanation on the meaning of ISO specific terms and expressions related to conformity assessment, as well as information about ISO's adherence to the WTO principles in the Technical Barriers to Trade (TBT) see the following URL: http://www.iso.org/iso/home/standards_development/resources-for-technical-work/foreword.htm

This second edition cancels and replaces the first edition (ISO 19072-2:2007), of which it constitutes a minor revision.

ISO 19072 consists of the following parts, under the general title *Road vehicles — Connection interface for pyrotechnic devices, two-way and three-way connections*:

- *Part 1: Pocket interface definition*
- *Part 2: Test methods and general performance requirements*
- *Part 3: Pyrotechnic device and harness connector assembly – type 1*
- *Part 4: Pyrotechnic device and harness connector assembly – type 2*

Introduction

Road vehicles integrate an increasing number of pyrotechnic devices contributing to occupant safety in vehicles (for example, frontal and side air bags, safety belt pretensioner, etc.).

To build the complete system providing the function requires a supply of various components from several different equipment makers. Vehicle manufacturers need to define a common specification to ensure that connectors designed and produced by the various equipment makers meet the same performance criteria and requirements.

In the current design of this vehicle equipment, three areas of connection have been identified:

- between the pyrotechnic device (e.g. initiator) and the harness connector;
- between the tab holder and the clip holder of the harness connector;
- between the harness connector and the electronic control module.

The connection between the pyrotechnic device and the harness connector is the only connection that can be standardized and forms the subject of this part of ISO 19072. Due to the location of the safety device in the vehicle, the connector design could be a right angle or straight.

A sealed variant of the pyrotechnic device/initiator harness connector assembly is defined in [Annex A](#).

A two-way (without ground) variant of the pyrotechnic device/initiator harness connector assembly is also defined in [Annex B](#).

A variant without a retainer of the pyrotechnic device/initiator harness connector assembly is defined in [Annex C](#).

Road vehicles — Connection interface for pyrotechnic devices, two-way and three-way connections —

Part 2: Test methods and general performance requirements

1 Scope

The purpose of this part of ISO 19072 is to define the performance criteria and requirements of a three-way connection interface, including ground connection, linking the pyrotechnic device and harness connector built into a road vehicle.

Performance criteria and requirements are also defined for a sealed variant of the pyrotechnic device/initiator harness connector assembly.

Performance criteria and requirements are also defined for a two-way (without ground) variant of the pyrotechnic device/initiator harness connector assembly.

2 Normative references

The following documents, in whole or in part, are normatively referenced in this document and are indispensable for its application. For dated references, only the edition cited applies. For undated references, the latest edition of the referenced document (including any amendments) applies.

ISO 8092-2, *Road vehicles — Connections for on-board electrical wiring harnesses — Part 2: Definitions, test methods and general performance requirements*

ISO 20653, *Road vehicles — Degrees of protection (IP code) — Protection of electrical equipment against foreign objects, water and access*

3 Terms and definitions

For the purposes of this document, the following terms and definitions apply.

3.1 connector

assembly used to connect several conductors together or a single conductor to an appliance

Note 1 to entry: Male/female connector is a housing containing male/female contacts and accessory items. A male connector may be permanently fixed to a wiring harness or to an appliance (an electronic control unit [ECU] for example). A female connector is generally permanently fixed to a wiring harness.

3.2 female contact

contact (including means for cable attachment) designed for electrical engagement on its inner surface and to accept entry of a male contact, thus forming an electrical connection

3.3 housing

connector without its contacts

3.4 locking device
mechanical system preventing unmating of a connector which can be released through a deliberate action

3.5 male contact
contact (including means for cable attachment) designed for electrical engagement on its outer surface and to enter a female contact, thus forming an electrical connection

3.6 retainer
ring holding an optional shorting clip (shunt) and providing coding and electrical insulation, generally made of plastic

Note 1 to entry: The shorting clip (shunt) may be omitted by decision between manufacturer and supplier.

3.7 short-circuit deactivation device
mechanical system used to open the short circuit

3.8 short-circuited initiator
inert initiator with two male contacts internally short-circuited with a shunt, used for testing

3.9 squib holder
part of the pyrotechnic device, holding the initiator and the retainer

3.10 initiator
part of the pyrotechnical device with two male contacts

4 Functional characteristics of mated connectors

4.1 General

Mated connectors shall meet the requirements specified in [4.2](#) to [4.16](#).

Unless other specifications are given, the temperature class to be taken into account for these tests (see ISO 8092-2) is class 2.

4.2 Visual examination

The test and corresponding requirements shall comply with ISO 8092-2.

4.3 Mating and unmating

The test has to be carried out in compliance with ISO 8092-2 by measuring the force applied on the connector.

The connector shall not be locked during the mating and unmating process unless otherwise specified.

The mating/unmating sequence shall comply with the one described in [Table 7](#).

The maximum connecting and disconnecting force measured on the connector shall be less than 40 N.

NOTE The movements of the mating sequence ([Table 7](#)) can be carried out simultaneously with the same force.

4.4 Resistance to tensile and compressive force between the connector and squib holder equipped with initiator and retainer

4.4.1 Test

4.4.1.1 General

The connector shall be locked for testing.

This test is a destructive test carried out on an assembly comprising a squib holder, an initiator with male contacts, and a retainer.

4.4.1.2 Straight connectors

The test is carried out on a new sample, applying the forces in the directions shown in [Figure 1](#) on the straight connector without its cable.

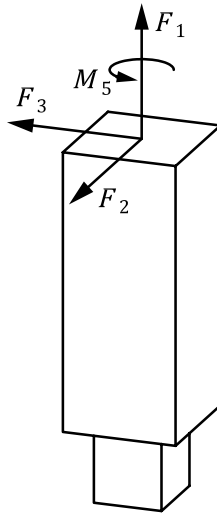

Key

- F_1 tensile force
- F_2 tensile and compressive forces
- F_3 tensile and compressive forces
- M_5 torque

Figure 1 — Direction of forces applied on straight connectors

4.4.1.3 Right-angle connectors

The test is carried out on a new sample, applying the forces F_4 and F_6 on the connector body where the cable exits the connector in the directions shown in [Figure 2](#).

Apply the force F_7 in the central axis of the connector as shown in [Figure 2](#).

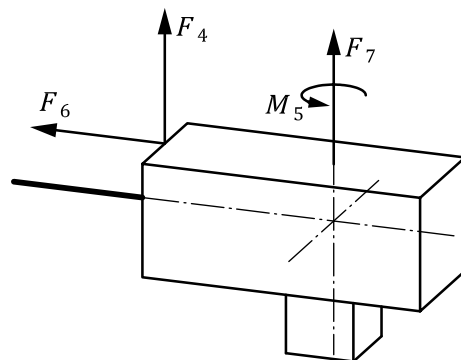

Key

- F_4 tensile and compressive forces
- F_6 tensile and compressive forces
- F_7 tensile force
- M_5 Torque

Figure 2 — Direction of forces applied on right-angle connectors

4.4.2 Requirements

4.4.2.1 Straight connectors

Mated straight connectors shall be able to withstand minimum forces and torque indicated in [Table 1](#).

Table 1 — Minimum tensile and compressive force values for straight connectors

Forces/torque applied to straight connectors	Minimum values of tensile/compressive forces or torque for straight connectors
F_1	120 N ^a
F_2	80 N
F_3	80 N
M_5	1,5 Nm

^a For the test carried out with force F_1 , after 10 cycles, the value of the minimum force is 100 N.

4.4.2.2 Right-angle connectors

Mated right-angle connectors shall be able to withstand minimum forces and torque indicated in [Table 2](#).

Table 2 — Minimum values of tensile/compressive forces or torque for right-angle connectors

Forces/torque applied to right-angle connectors	Minimum values of tensile/compressive forces or torque for right-angle connectors
F_4	70 N
M_5	1,5 Nm
F_6	80 N
F_7	100 N

4.5 Mechanical strength of the retainer in the squib holder

4.5.1 Test

The test is carried out on a new sample by applying the force in the direction shown in [Figure 3](#) on the retainer installed in the squib holder.

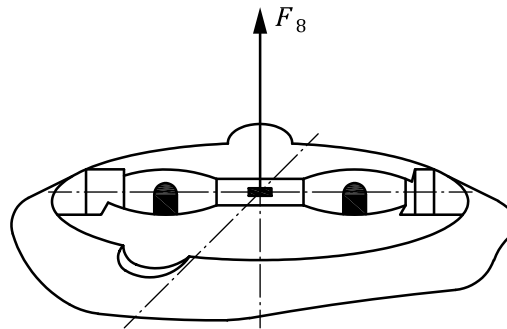

Key

F_8 force applied to retainer installed in squib holder

Figure 3 — Direction of force applied to the retainer installed in the squib holder

4.5.2 Requirements

The retainer installed in the squib holder without mated connector shall withstand minimum force F_8 indicated in [Table 3](#).

Table 3 — Minimum force applied to the retainer installed in the squib holder

Force applied to the retainer installed in the squib holder	Minimum value of force applied to the retainer installed in the squib holder
F_8	10 N

4.6 Combination of temperature/humidity/vibration

4.6.1 Test

Samples from a series application are assembled with a cable, mated, and preconditioned for 48 h in a ventilated heat chamber at $(65 \pm 2) ^\circ\text{C}$.

The mated connectors are then secured to a vibrating table with the male contacts connected in series on the short-circuited initiator side and connected to a direct current source delivering an intensity of 50 mA, so that the variation in contact resistance can be determined throughout the test. Apply the frequency variations indicated in [Table 4](#) to the connection by logarithmic modulation of 1 octave/min for 48 h per axis (i.e. 144 h in total) using the test setup described in [Figures 4](#) and [5](#).

Table 4 — Test parameters for combined temperature/humidity/vibration test

Frequency F Hz	Displacement/ acceleration
$5 \leq F \leq 25$	$\pm 1,2$ mm
$25 < F \leq 200$	3 g ^a
$200 < F \leq 2\ 000$	1 g

^a The conventional value for acceleration due to gravity is 9,806 65 m/s².

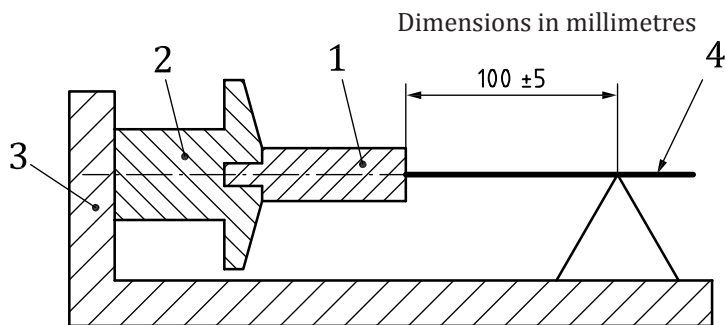

Key

- 1 straight connector being tested
- 2 short-circuited initiator
- 3 vibrating table
- 4 cable fixed without tension force on connector

Figure 4 — Straight connector mounting for combined temperature/humidity/vibration test

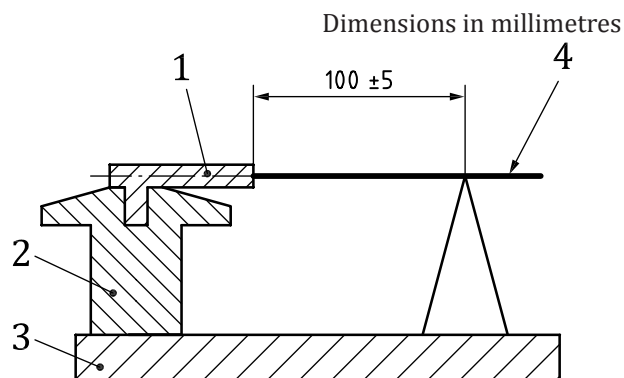

Key

- 1 right-angle connector being tested
- 2 short-circuited initiator
- 3 vibrating table
- 4 cable fixed without tension force on connector

Figure 5 — Right-angle connector mounting for combined temperature/humidity/vibration test

This test is carried out in a heat chamber in which the relative humidity and temperature variation cycle, applied at the same time as the vibration cycle, shall comply with [Figure 6](#).

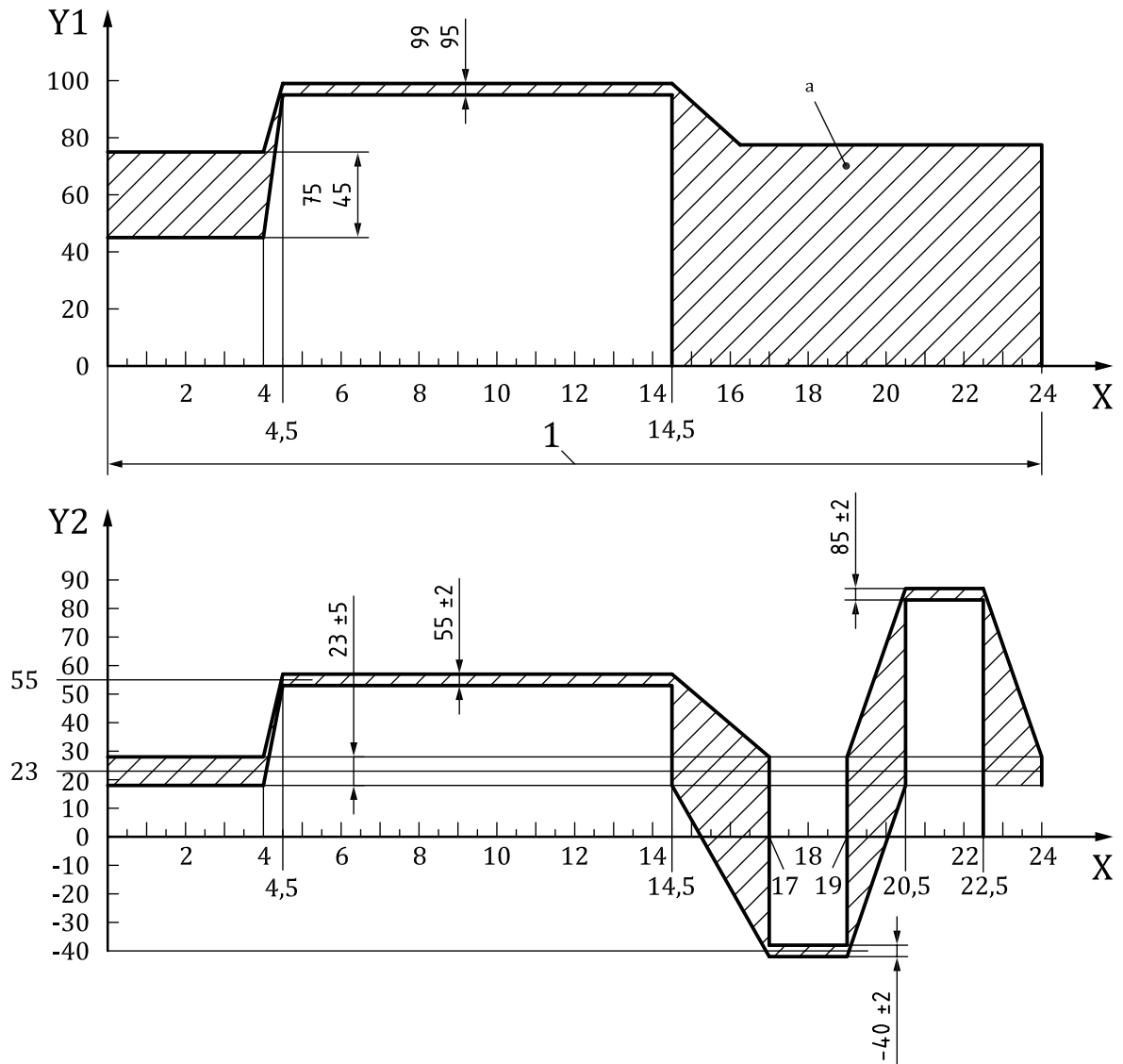

Key

- 1 1 cycle
- Y1 relative humidity as percentage
- Y2 temperature of the test chamber in °C
- X time in hours
- a Relative humidity is not monitored in this range for temperatures of less than 0 °C.

Figure 6 — Temperature cycle for the combined temperature/humidity/vibration test

4.6.2 Requirements

Variation of contact resistance is measured continuously during the test. It shall never exceed 50 mΩ. The minimum recording threshold is set at 25 mΩ.

Contact resistance shall be measured using the test setup shown in [Figure 7](#). The resistance of the wires and the male contacts, except the contact resistance, has to be subtracted from the measurement.

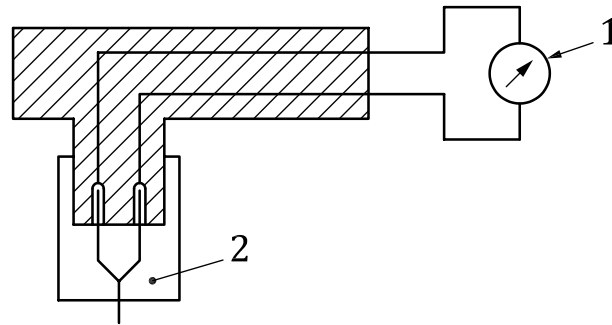

Key

- 1 resistance monitoring unit according to ISO 8092-2
- 2 short-circuited initiator

Figure 7 — Test setup used to measure contact resistance

4.7 Coding

4.7.1 Test

The test consists in carrying out a mating test (see 4.3) between a connector and all combinations of alternate retainer codes.

4.7.2 Requirements

It shall be impossible to make electrical connection with a force less than or equal to 100 N.

It shall be impossible to open the shorting bar with a force less than or equal to 150 N.

4.8 Polarisation

4.8.1 Test

The test consists in carrying out a mating test (see 4.3) between a connector and a counterpart in all positions other than the correct position.

4.8.2 Requirements

It shall be impossible to make electrical connection with a force less than or equal to 100 N.

It shall be impossible to open the shorting bar with a force less than or equal to 200 N.

4.9 Contact resistance (voltage drop), millivolt test

4.9.1 Test

4.9.1.1 General

The test voltage shall not exceed 20 mV under direct current or 20 mV peak voltage under alternating current in open circuit. The intensity of the test current shall not exceed 100 mA.

4.9.1.2 Signal contact resistance

Signal contact resistance shall be measured using the test setup shown in [Figure 8](#).

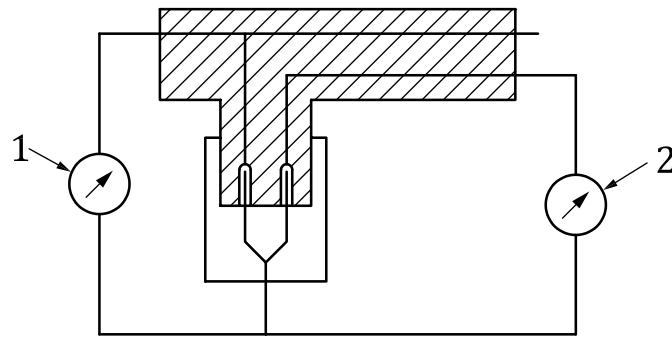

Key

- 1 resistance monitoring unit 1 according to ISO 8092-2
- 2 resistance monitoring unit 2 according to ISO 8092-2

Figure 8 — Test setup used to measure signal contact resistance (millivolt test)

4.9.1.3 Ground contact resistance

Ground contact resistance shall be measured using the test setup shown in [Figure 9](#).

Ground contact resistance does not include internal resistance of the squib holder and cable.

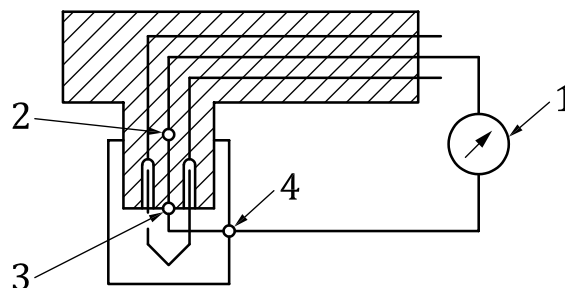

Key

- 1 resistance monitoring unit 1 according to ISO 8092-2
- 2 retainer – connector third-way contact
- 3 retainer – squib holder contact
- 4 measurement point on squib holder outer surface

Figure 9 — Test setup used to measure ground contact resistance (millivolt test)

4.9.2 Requirements

4.9.2.1 Maximum signal contact resistance

Maximum signal contact resistance shall comply with the values given in [Table 5](#).

Signal contact resistance does not include internal resistance of the initiator and cable.

Table 5 — Maximum signal contact resistance

Male contact category	Signal contact resistance	
	Initial maximum value	Maximum value after tests
∅ 1 mm	6 mΩ	Initial value + 4 mΩ

4.9.2.2 Maximum contact resistance between ground and squib holder

Maximum contact resistance between ground and squib holder shall comply with the values given in [Table 6](#).

Table 6 — Maximum contact resistance between ground and squib holder

Maximum contact resistance between ground and squib holder	
Initial maximum value	Maximum value after tests
100 mΩ	500 mΩ

4.10 Insulation resistance

The test and corresponding requirements shall comply with ISO 8092-2.

4.11 Withstand voltage

The test and corresponding requirements shall comply with ISO 8092-2, except for the test measurement voltage which is set at 750 V for alternating current and 1 000 V for direct current.

4.12 Thermal ageing

The test and corresponding requirements shall comply with ISO 8092-2.

4.13 Opening and closing of the short-circuit

The test setup used to detect ground and short-circuit is shown in [Figure 10](#).

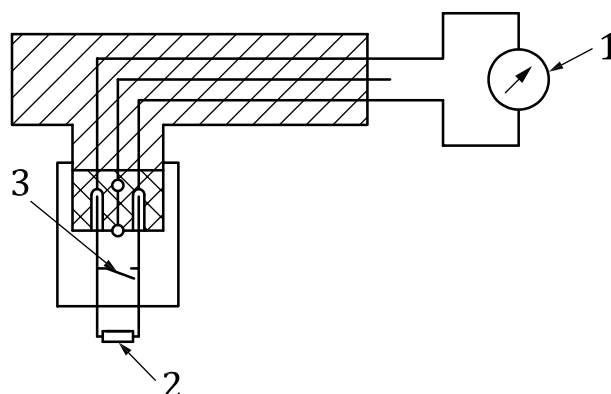

Key

- 1 resistance monitoring unit 1 according to ISO 8092-2
- 2 test resistance of $(10 \pm 0,1) \Omega$
- 3 retainer short-circuit

Figure 10 — Test setup used to detect ground and short-circuit

Functional sequence requirements for opening and closing of the short-circuit are explained in [Table 7](#). This sequence has to be observed regardless of the connector orientation.

Connector mating phases 1 and 2 may be realized in one or two operations.

Table 7 — Mating sequence

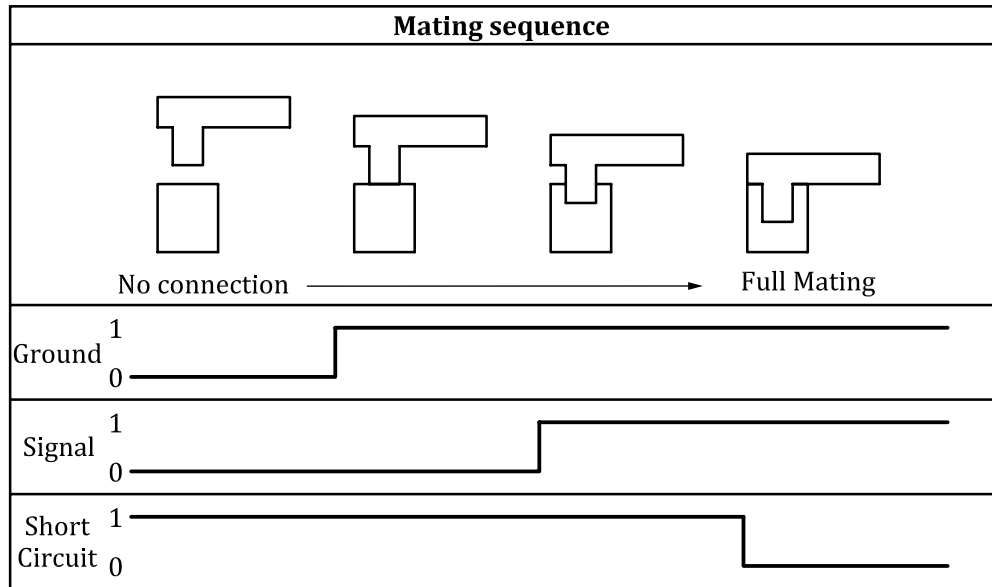

4.14 Short-circuit resistance

4.14.1 Test

The test setup shown in [Figure 11](#) shall be used to create the short-circuit and measure electrical resistance on the resistance monitoring unit.

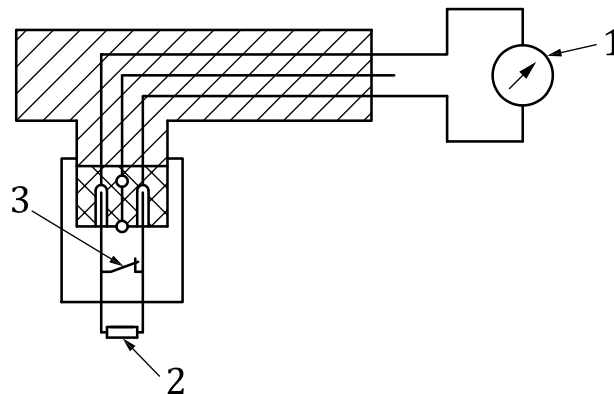

Key

- 1 resistance monitoring unit according to ISO 8092-2
- 2 opened initiator (R1)
- 3 short-circuit electrical connection (R2)

NOTE R1 > R2.

Figure 11 — Test setup used to measure short-circuit resistance

4.14.2 Requirements

Before and after environment tests, the resistance shall be measured as no more than 300 mΩ.

4.15 Rapid change of temperature (thermal shock)

The test and corresponding requirements shall comply with ISO 8092-2.

4.16 Chemical fluids

The test and corresponding requirements shall comply with ISO 8092-2.

5 Test sequences

The test sequences for each group of samples are shown in [Table 8](#).

Each group shall contain at least 10 samples.

Unless other specifications are given, all the samples in a test group shall be used for the test.

Table 8 — Test sequences and requirements

Test		Group of test samples										Requirement
Title	Paragraph	A	B	C	D	E	F	G	H	Paragraph		
Visual examination	4.2	1 ^a 3	1 6	1 5	1 9	1 3	1 6	1 6	1 6	4.2		
Mating and unmating (first operation)	4.3		2						3	4.3		
Mating and unmating (tenth operation)	4.3				3			2	4	4.3		
Resistance to tensile and compressive force between the connector and squib holder equipped with initiator and retainer	4.4.1		5							4.4.2		
Mechanical strength of the retainer in the squib holder	4.5.1							5		4.5.2		
Combination of temperature/humidity/vibration	4.6.1			3			3			4.6.2		
Coding	4.7.1	2								4.7.2		
Polarisation	4.8.1					2				4.8.2		
Contact resistance (voltage drop), millivolt test	4.9.1		3		2 4 6		2 4			4.9.2		
Signal contact												
Ground contact												
Insulation resistance	4.10				7					4.10		
Withstand voltage	4.11				8		5		5	4.11		
Thermal ageing	4.12							4		4.12		

^a Order in which the tests shall be carried out (1, 2, 3, etc.).

Table 8 (continued)

Test		Group of test samples								Requirement
Title	Paragraph	A	B	C	D	E	F	G	H	Paragraph
Opening and closing of the short-circuit	4.13							3		4.13
Short-circuit resistance	4.14.1		4	2 4						4.14.2
Rapid change of temperature (thermal shock)	4.15				5					4.15
Chemical fluids	4.16								2	4.16
^a Order in which the tests shall be carried out (1, 2, 3, etc.).										

Annex A (normative)

Sealed variant of the pyrotechnic device/initiator harness connector assembly

A.1 Functional characteristics of mated connectors

A.1.1 General

All contents of the main document are applicable for the sealed design except [Table 8](#) which is replaced by [Table A.1](#).

Unless otherwise agreed between customer and supplier, the temperature class to be taken into account for these tests (see ISO 8092-2) is class 3.

A.1.2 Mating and unmating

Maximum connecting and disconnecting force measured on the connector shall be less than 60 N.

A.2 Validation tests

Test IPX9K as described in ISO 20653 shall be used.

A.3 Test sequences

The test sequences for each group of samples are shown in [Table A.1](#).

Each group shall contain at least 10 samples.

Unless other specifications are given, all the samples in a test group shall be used for the test.

Table A.1 — Test sequences and requirements

Test		Group of test samples										Requirement
Title	Para-graph	A	B	C	D	E	F	G	H	I	Paragraph	
Visual examination	4.2	1 ^a 3	1 6	1 5	1 9	1 3	1 6	1 5	1 8	1 6	4.2	
Mating and unmating (first operation)	4.3		2							3	4.3	
Mating and unmating (tenth operation)	4.3				3			2		4	4.3	
Resistance to tensile and compressive force between the connector and squib holder equipped with initiator and retainer	4.4.1		5								4.4.2	

^a Order in which the tests shall be carried out (1, 2, 3, etc.).

Table A.1 (continued)

Test		Group of test samples									Requirement				
Title	Para-graph	A	B	C	D	E	F	G	H	I	Paragraph				
Mechanical strength of the retainer in the squib holder	4.5.1							4			4.5.2				
Water tightness	A.2								5		A.3				
Combination of temperature/humidity/vibration	4.6.1			3			3				4.6.2				
Coding	4.7.1	2									4.7.2				
Polarisation	4.8.1					2					4.8.2				
Contact resistance (voltage drop), millivolt test	4.9.1	3			2	4	6		2	4		2	7		4.9.2
Signal contact															
Ground contact															
Insulation resistance	4.10				7				3	6					4.10
Withstand voltage	4.11				8		5				5				4.11
Thermal ageing	4.12								4						4.12
Opening and closing of the short-circuit	4.13							3							4.13
Short-circuit resistance	4.14.1		4	2	4										4.14.2
Rapid change of temperature (thermal shock)	4.15				5										4.15
Chemical fluids	4.16									2					4.16

^a Order in which the tests shall be carried out (1, 2, 3, etc.).

Annex B (normative)

Two-way (without ground) variant of the pyrotechnic device/ initiator harness connector assembly

B.1 Connector mating sequence

All contents of the main document are applicable for the two-way design except all items related to ground connection (including [Table 8](#) which is replaced by [Table B.2](#)).

Functional sequence requirements for opening and closing of the short-circuit are explained in [Table B.1](#). This sequence has to be observed regardless of the connector orientation.

Connector mating phases 1 and 2 may be realized in one or two operations.

Table B.1 — Mating sequence

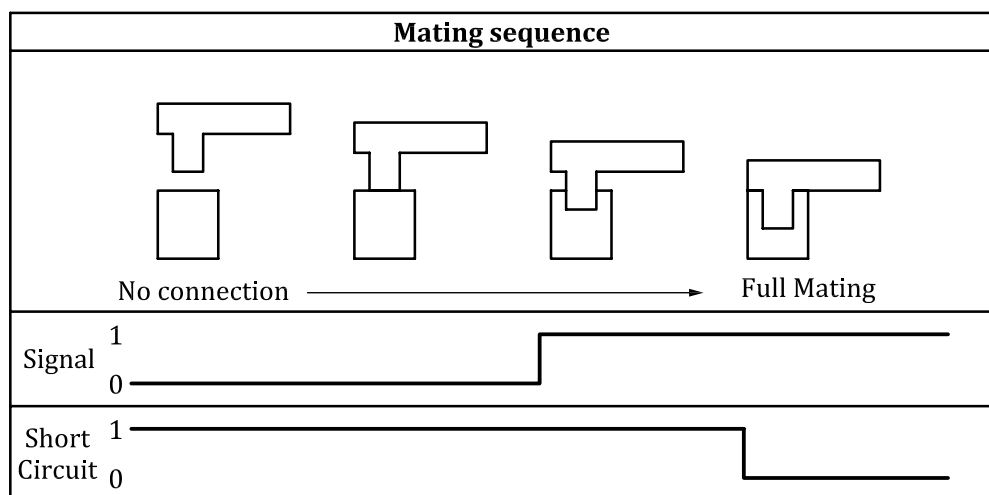

B.2 Test sequences

The test sequences for each group of samples are shown in [Table B.2](#).

Each group shall contain at least 10 samples.

Unless other specifications are given, all the samples in a test group shall be used for the test.

Table B.2 — Test sequences and requirements

Test		Group of test samples												Requirement
Title	Paragraph	A	B	C	D	E	F	G	H				Paragraph	
Visual examination	4.2	1 ^a 3	1 6	1 5	1 9	1 3	1 6	1 6	1 6				4.2	
Mating and unmating (first operation)	4.3		2						3				4.3	
Mating and unmating (tenth operation)	4.3				3			2	4				4.3	
Resistance to tensile and compressive force between the connector and squib holder equipped with initiator and retainer	4.4.1		5										4.4.2	
Mechanical strength of the retainer in the squib holder	4.5.1							5					4.5.2	
Combination of temperature/humidity/vibration	4.6.2			3			3						4.6.2	
Coding	4.7.1	2											4.7.2	
Polarisation	4.8.1					2							4.8.2	
Contact resistance (voltage drop), millivolt test Signal contact	4.9.1		3		2 4 6		2 4						4.9.2	
Insulation resistance	4.10				7								4.10	
Withstand voltage	4.11				8		5		5				4.11	
Thermal ageing	4.12							4					4.12	
Opening and closing of the short-circuit	4.13							3					4.13	
Short-circuit resistance	4.14.1		4	2 4									4.14.2	
Rapid change of temperature (thermal shock)	4.15				5								4.15	
Chemical fluid	4.16												4.16	

^a Order in which tests shall be carried out (1, 2, 3, etc.).

Annex C (normative)

Variant without retainer of the pyrotechnic device/initiator harness connector assembly

C.1 Test sequences

The test sequences for each group of samples are shown in [Table C.1](#).

Each group shall contain at least 10 samples.

Unless other specifications are given, all the samples in a test group shall be used for the test.

Table C.1 — Test sequences and requirements

Test		Group of test samples										Requirement
Title	Paragraph	A		B		C			D		E	Paragraph
Visual examination	4.2	1 ^a	5	1	3	1	8	1	7	1	5	4.2
Mating and unmating (first operation)	4.3	2							3		4.3	
aw	4.4.1	4									4.4.2	
Combination of temperature/humidity/vibration	4.6.1			2					3		4.6.2	
Contact resistance (voltage drop), millivolt test Signal contact	4.9.1	3				2	3	5	2	5		4.9.2
Insulation resistance	4.10					6					4.10	
Withstand voltage	4.11					7			6	4	4.11	
Thermal ageing	4.12								4		4.12	
Rapid change of temperature (thermal shock)	4.15					4					4.15	
Chemical fluids	4.16								2		4.16	

^a Order in which the tests shall be carried out (1, 2, 3, etc.).

Bibliography

- [1] ISO 178, *Plastics — Determination of flexural properties*
- [2] ISO 16750-1, *Road vehicles — Environmental conditions and testing for electrical and electronic equipment — Part 1: General*
- [3] ISO 16750-2, *Road vehicles — Environmental conditions and testing for electrical and electronic equipment — Part 2: Electrical loads*
- [4] ISO 16750-3, *Road vehicles — Environmental conditions and testing for electrical and electronic equipment — Part 3: Mechanical loads*
- [5] ISO 16750-4, *Road vehicles — Environmental conditions and testing for electrical and electronic equipment — Part 4: Climatic loads*
- [5] ISO 16750-5, *Road vehicles — Environmental conditions and testing for electrical and electronic equipment — Part 5: Chemical loads*

British Standards Institution (BSI)

BSI is the national body responsible for preparing British Standards and other standards-related publications, information and services.

BSI is incorporated by Royal Charter. British Standards and other standardization products are published by BSI Standards Limited.

About us

We bring together business, industry, government, consumers, innovators and others to shape their combined experience and expertise into standards-based solutions.

The knowledge embodied in our standards has been carefully assembled in a dependable format and refined through our open consultation process. Organizations of all sizes and across all sectors choose standards to help them achieve their goals.

Information on standards

We can provide you with the knowledge that your organization needs to succeed. Find out more about British Standards by visiting our website at bsigroup.com/standards or contacting our Customer Services team or Knowledge Centre.

Buying standards

You can buy and download PDF versions of BSI publications, including British and adopted European and international standards, through our website at bsigroup.com/shop, where hard copies can also be purchased.

If you need international and foreign standards from other Standards Development Organizations, hard copies can be ordered from our Customer Services team.

Subscriptions

Our range of subscription services are designed to make using standards easier for you. For further information on our subscription products go to bsigroup.com/subscriptions.

With **British Standards Online (BSOL)** you'll have instant access to over 55,000 British and adopted European and international standards from your desktop. It's available 24/7 and is refreshed daily so you'll always be up to date.

You can keep in touch with standards developments and receive substantial discounts on the purchase price of standards, both in single copy and subscription format, by becoming a **BSI Subscribing Member**.

PLUS is an updating service exclusive to BSI Subscribing Members. You will automatically receive the latest hard copy of your standards when they're revised or replaced.

To find out more about becoming a BSI Subscribing Member and the benefits of membership, please visit bsigroup.com/shop.

With a **Multi-User Network Licence (MUNL)** you are able to host standards publications on your intranet. Licences can cover as few or as many users as you wish. With updates supplied as soon as they're available, you can be sure your documentation is current. For further information, email bsmusales@bsigroup.com.

BSI Group Headquarters

389 Chiswick High Road London W4 4AL UK

Revisions

Our British Standards and other publications are updated by amendment or revision.

We continually improve the quality of our products and services to benefit your business. If you find an inaccuracy or ambiguity within a British Standard or other BSI publication please inform the Knowledge Centre.

Copyright

All the data, software and documentation set out in all British Standards and other BSI publications are the property of and copyrighted by BSI, or some person or entity that owns copyright in the information used (such as the international standardization bodies) and has formally licensed such information to BSI for commercial publication and use. Except as permitted under the Copyright, Designs and Patents Act 1988 no extract may be reproduced, stored in a retrieval system or transmitted in any form or by any means – electronic, photocopying, recording or otherwise – without prior written permission from BSI. Details and advice can be obtained from the Copyright & Licensing Department.

Useful Contacts:

Customer Services

Tel: +44 845 086 9001

Email (orders): orders@bsigroup.com

Email (enquiries): cservices@bsigroup.com

Subscriptions

Tel: +44 845 086 9001

Email: subscriptions@bsigroup.com

Knowledge Centre

Tel: +44 20 8996 7004

Email: knowledgecentre@bsigroup.com

Copyright & Licensing

Tel: +44 20 8996 7070

Email: copyright@bsigroup.com



...making excellence a habit.™