

BS ISO 19030-2:2016



BSI Standards Publication

Ships and marine technology — Measurement of changes in hull and propeller performance

Part 2: Default method

National foreword

This British Standard is the UK implementation of ISO 19030-2:2016.

The UK participation in its preparation was entrusted to Technical Committee SME/32, Ships and marine technology - Steering committee.

A list of organizations represented on this committee can be obtained on request to its secretary.

This publication does not purport to include all the necessary provisions of a contract. Users are responsible for its correct application.

© The British Standards Institution 2016.

Published by BSI Standards Limited 2016

ISBN 978 0 580 83590 2

ICS 47.020.99

Compliance with a British Standard cannot confer immunity from legal obligations.

This British Standard was published under the authority of the Standards Policy and Strategy Committee on 31 December 2016.

Amendments/corrigenda issued since publication

Date	Text affected
------	---------------

**Ships and marine technology —
Measurement of changes in hull and
propeller performance —**

**Part 2:
Default method**

*Navires et technologie maritime — Mesurage de la variation de
performance de la coque et de l'hélice —*

Partie 2: Méthode par défaut



COPYRIGHT PROTECTED DOCUMENT

© ISO 2016, Published in Switzerland

All rights reserved. Unless otherwise specified, no part of this publication may be reproduced or utilized otherwise in any form or by any means, electronic or mechanical, including photocopying, or posting on the internet or an intranet, without prior written permission. Permission can be requested from either ISO at the address below or ISO's member body in the country of the requester.

ISO copyright office
Ch. de Blandonnet 8 • CP 401
CH-1214 Vernier, Geneva, Switzerland
Tel. +41 22 749 01 11
Fax +41 22 749 09 47
copyright@iso.org
www.iso.org

Contents

Page

Foreword	v
Introduction	vi
1 Scope	1
2 Normative references	1
3 Terms and definitions	1
4 Measurement parameters	2
4.1 General.....	2
4.2 Primary parameters.....	2
4.3 Secondary parameters.....	3
4.4 Sensor installation, maintenance and calibration.....	3
4.5 External information.....	4
5 Measurement procedures	5
5.1 General.....	5
5.2 Data acquisition.....	5
5.3 Data storage.....	6
5.4 Data preparation.....	6
5.4.1 General.....	6
5.4.2 Data preparation frequency.....	7
5.4.3 Data retrieval.....	7
5.4.4 Data compilation.....	7
5.4.5 Data filtering and validation.....	8
5.4.6 Correction for environmental factors.....	8
5.4.7 Calculation of performance values (PVs).....	8
6 Calculation of performance indicators (PIs)	9
6.1 General.....	9
6.2 Definition of PIs.....	9
6.3 Calculation of PIs.....	9
6.3.1 General.....	9
6.3.2 Determination of reference conditions.....	10
6.3.3 Establishment of reference period and evaluation period.....	10
6.3.4 Extraction of subsets of PVs from the complete set with PVs that fulfil reference conditions for reference conditions for reference period(s) and evaluation period.....	11
6.3.5 Calculation of the PI.....	11
7 Accuracy of PIs	12
7.1 General.....	12
7.2 Guidance on the expected accuracy of PIs.....	12
Annex A (informative) Process of this document	14
Annex B (normative) Approximating delivered power based on calculations of shaft power	15
Annex C (normative) Approximating delivered power based on calculations of brake power	16
Annex D (informative) SFOC reference curve	19
Annex E (normative) Calculation of true wind speed and direction	21
Annex F (informative) Procedure to obtain ship specific power-speed-draught-trim databases	24
Annex G (normative) Correction for wind resistance	25
Annex H (informative) Protocol to export data from data logger	27
Annex I (normative) Outlier detection	32
Annex J (normative) Validation	34

Annex K (informative) Method for calculating power performance values (PPV) and power performance indicators (PPI)	35
Bibliography	37

Foreword

ISO (the International Organization for Standardization) is a worldwide federation of national standards bodies (ISO member bodies). The work of preparing International Standards is normally carried out through ISO technical committees. Each member body interested in a subject for which a technical committee has been established has the right to be represented on that committee. International organizations, governmental and non-governmental, in liaison with ISO, also take part in the work. ISO collaborates closely with the International Electrotechnical Commission (IEC) on all matters of electrotechnical standardization.

The procedures used to develop this document and those intended for its further maintenance are described in the ISO/IEC Directives, Part 1. In particular the different approval criteria needed for the different types of ISO documents should be noted. This document was drafted in accordance with the editorial rules of the ISO/IEC Directives, Part 2 (see www.iso.org/directives).

Attention is drawn to the possibility that some of the elements of this document may be the subject of patent rights. ISO shall not be held responsible for identifying any or all such patent rights. Details of any patent rights identified during the development of the document will be in the Introduction and/or on the ISO list of patent declarations received (see www.iso.org/patents).

Any trade name used in this document is information given for the convenience of users and does not constitute an endorsement.

For an explanation on the meaning of ISO specific terms and expressions related to conformity assessment, as well as information about ISO's adherence to the World Trade Organization (WTO) principles in the Technical Barriers to Trade (TBT) see the following URL: www.iso.org/iso/foreword.html.

The committee responsible for this document is ISO/TC 8, *Ships and marine technology*, Subcommittee SC 2, *Marine environment protection*.

A list of all parts in the ISO 19030 series can be found on the ISO website.

Introduction

Hull and propeller performance refers to the relationship between the condition of a ship's underwater hull and propeller and the power required to move the ship through water at a given speed. Measurements of changes in ship specific hull and propeller performance over time make it possible to indicate the impact of hull and propeller maintenance, repair and retrofit activities on the overall energy efficiency of the ship in question.

The aim of this document is to prescribe practical methods for measuring changes in ship specific hull and propeller performance and to define a set of relevant performance indicators for hull and propeller maintenance, repair and retrofit activities. The methods are not intended for comparing the performance of ships of different types and sizes (including sister ships) nor to be used in a regulatory framework.

This document consists of three parts.

- ISO 19030-1 outlines general principles for how to measure changes in hull and propeller performance and defines a set of performance indicators for hull and propeller maintenance, repair and retrofit activities.
- ISO 19030-2 defines the default method for measuring changes in hull and propeller performance and for calculating the performance indicators. It also provides guidance on the expected accuracy of each performance indicator.
- ISO 19030-3 outlines alternatives to the default method. Some will result in lower overall accuracy but increase applicability of the standard. Others may result in same or higher overall accuracy but include elements which are not yet broadly used in commercial shipping.

The general principles outlined, and methods defined, in this document are based on measurement equipment, information, procedures and methodologies which are generally available and internationally recognized.

[Clause 4](#) defines the primary and secondary parameters as well as external information needed. [Clause 5](#) defines how measurement data are to be acquired, stored and prepared. [Clause 6](#) defines how the performance indicators are to be calculated. [Clause 7](#) provides guidance on the expected accuracy of each performance indicator.

[Annex A](#) illustrates the process in terms of a flow chart.

Ships and marine technology — Measurement of changes in hull and propeller performance —

Part 2: Default method

1 Scope

This document defines the default method for measuring changes in hull and propeller performance and calculating a set of basic performance indicators. Finally, it provides guidance on the expected accuracy of each performance indicator.

This document is applicable for commercial ship types of the displacement type driven by conventional fixed pitch propeller(s) where the objective is to compare the hull and propeller performance of the same ship to itself over time.

NOTE Support for additional configurations (e.g. variable pitch propellers) will, if justified, be included in later revisions of this document.

2 Normative references

The following documents are referred to in the text in such a way that some or all of their content constitutes requirements of this document. For dated references, only the edition cited applies. For undated references, the latest edition of the referenced document (including any amendments) applies.

ISO 3046-1, *Reciprocating internal combustion engines — Performance — Part 1: Declarations of power, fuel and lubricating oil consumptions, and test methods — Additional requirements for engines for general use*

ISO 15016:2015, *Ships and marine technology — Guidelines for the assessment of speed and power performance by analysis of speed trial data*

ISO 19030-1:2016, *Ships and marine technology — Measurement of changes in hull and propeller performance — Part 1: General principles*

3 Terms and definitions

For the purposes of this document, the following terms and definitions apply.

ISO and IEC maintain terminological databases for use in standardization at the following addresses:

- IEC Electropedia: available at <http://www.electropedia.org/>
- ISO Online browsing platform: available at <http://www.iso.org/obp>

3.1 changes in hull and propeller performance

changes in delivered power required to move the ship through water at a given speed or equivalently changes in speed through water at a given delivered power, given unchanged transmission efficiency, and the same environmental conditions and operational profile

3.2 reference period

period in time of a certain length used to establish a baseline

3.3
evaluation period

period in time after the *reference period* (3.2), used for comparing with the baseline

3.4
reference conditions

set of comparable conditions of environmental and/or operational factors or a set of ranges of such conditions

3.5
tabular format

formatting data in rows and columns, to break down specific data into a quickly scannable layout

3.6
unique identifier

identifier which is guaranteed to be unique among all identifiers used for those objects and for a specific purpose

4 Measurement parameters

4.1 General

This clause describes the primary and secondary parameters for measuring changes in hull and propeller performance.

4.2 Primary parameters

In ISO 19030-1, ship speed through water, V , and delivered power, P_D , are defined as the two primary measurement parameters for measuring changes in hull and propeller performance.

Ship speed through water shall be measured directly, in knots, using a speed log with a minimum sensor accuracy of $\pm 1\%$, at $1\sigma^1$ of the speed of the ship, or $\pm 0,1$ knots, at 1σ (both as specified by the sensor manufacturer) whichever is greater.

NOTE Since the overall accuracy associated with measurements of hull and propeller performance is highly sensitive to uncertainties in the measurement of speed, this requirement is intentionally stricter than current SOLAS requirements.

Delivered power shall be approximated based on calculations of shaft power, P_S , from measurements of shaft torque and shaft revolutions following [Annex B](#) or, if a torque meter with required signal quality is not available and the conditions defined in [Annex C](#) are fulfilled, shall be based on calculations of brake power, P_B , from an engine-specific SFOC (specific fuel oil consumption) reference curve defined in [Annex D](#), continuous measurements of fuel flow and temperature and bunker analysis data (calorific value, density and density change rate for the fuel being consumed).

The approaches to calculating shaft power and brake power, as well as minimum required sensors and sensor accuracies for each, are specified in [Annex B](#) and [Annex C](#), respectively.

The same approach to approximating delivered power shall be used throughout both the reference and evaluation periods.

1) Confidence interval of 66 %.

4.3 Secondary parameters

For the isolation of comparable reference conditions and as input to data preparation (filtering, normalization), both environmental factors and the ship's operational profile shall be measured.

NOTE Not all factors influencing measured performance are addressed in this document, e.g. frequency of rudder movement or side current effects. Future revisions of this document may address such factors.

The minimum sensor requirements for the secondary measurement parameters are defined in [Table 1](#).

Table 1 — Minimum sensor requirements, secondary measurement parameters

Parameter	Acceptable measurement device/source ^a	Unit
Relative wind speed and direction measured at the height of the anemometer	Ship anemometer — minimum sensor accuracy of ± 1 m/s, $\pm 5^\circ$	m/s, °
Speed over ground	(D) GPS	knots
Ship heading	Gyro compass, or compass — DGPS	°
Shaft revolutions	Pick-up, optical sensor, ship revs counter with minimum sensor accuracy of $\pm 0,5$ %, 1σ	rev/min
Static draught fore and aft	Information from loading or stability computer or equivalent sources for static draught. NOTE Preference for observed draught, when available.	m
Water depth	Ship echo sounder with minimum sensor accuracy of: — $\pm 0,5$ m on the 20 m range scale, respectively; — ± 5 m on the 200 m range scale; — $\pm 2,5$ % of the indicated depth, whichever is greater.	m
Rudder angle	Rudder angle indicator — minimum sensor accuracy of $\pm 1^\circ$	°
Seawater temperature	Thermometer	°C
Ambient air temperature	Thermometer	°C
Air pressure	Barometer	Pa
^a Minimum sensor accuracy refers to the sensor manufacturer's specified accuracy.		

For rudder angle, the following convention shall be followed: values shall range from -180° to 180° , with 0° meaning amidship, positive values meaning starboard.

True wind is calculated from relative wind at the height of the anemometer according to the procedures in [Annex E](#). Wind direction and ship heading are defined in [Figure E.2](#).

If ambient air temperature is not measured, a constant air temperature value of 15°C shall be used.

If air pressure is not measured, a constant air pressure value of $101,325$ kPa (1 atm) shall be used.

For vessels with twin screws, shaft revolutions shall be measured on both shafts.

It is recommended to use the same sensor type on both shafts.

4.4 Sensor installation, maintenance and calibration

All sensors shall be installed, maintained and calibrated as per manufacturer specification and as per the requirements of the ship owner's planned maintenance system. The same set of sensors and the same sensor settings shall be used in the reference period and the evaluation period. Furthermore, data

shall be logged with the same precision over the reference and evaluation period and to at least three significant figures for all parameters (except time and date).

It is underlined that speed log recalibration shall only be done according to the manufacturer specification, as the accuracy of the hull and propeller performance indicator depends critically on the correct functioning of the speed through water sensor.

4.5 External information

Speed-power data shall be available for the vessel in question. These may originate from the following power estimation approaches:

- from full-scale speed trials that were conducted and analysed according to ISO 15016;
- from towing tank tests having demonstrated compliance with international standards of quality;
- from computational fluid dynamics (CFD) simulations conducted and analysed following generally accepted state-of-the-art procedures, e.g. those recommended by the International Towing Tank Conference (ITTC);

It has to be documented how the speed-power data have been obtained.

Displacement tables and/or formulae for the vessel in question shall be made available (needed to convert measured draught and trim into displacement).

The speed-power data have to cover the actual operational speed-power range of the vessel in question and it shall be available for the actual operational loading conditions (draught, trim) of the vessel in question. Data from the same approach shall be used consistently over the whole operational range of, and over both reference and evaluation periods for, the vessel in question.

If a significant change in the operational behaviour of the vessel occurs, e.g. by following a slow-steaming regime during one period but not during another period or by starting to use trim optimization, high resolution speed-power-draught-trim data shall be used to ensure that the estimated level of accuracy (see 7.2) is maintained. [Annex F](#) describes a procedure on how to obtain high-resolution speed-power-draught-trim databases.

High resolution speed-power-draught-trim data is generally recommended in case of high variability in the operational parameters.

If speed-power reference data are not available for the actual operational speed-power range of the vessel or for the actual operational loading range of the vessel, additional speed-power data have to be estimated as follows.

If speed-power reference data are available for

- displacement values within ± 5 % of the actual displacement, and
- for trim values within $\pm 0,2$ % of the length between perpendiculars of the actual trim of the vessel,

the speed-power reference data for the displacement closest to the actual displacement shall be used as reference data and remaining displacement variations shall be corrected for by following the Admiralty formula [see [Formula \(1\)](#)]:

$$V_2 = V_1 \left(\frac{\Delta_1^{2/3}}{\Delta_2^{2/3}} \right)^{1/3} \quad (1)$$

where

V_1 is the speed at measured displacement;

V_2 is the speed at reference displacement;

Δ_1 is the measured displacement;

Δ_2 is the reference displacement.

Otherwise, additional speed-power data shall be estimated by applying the above specified power estimation approaches. It has to be documented how the data have been obtained.

If speed-power reference data are not available for the actual operational speed-power range of the vessel or the actual loading conditions of the vessel, additional speed trials, towing tank tests or CFD calculations should be performed to obtain additional speed-power data. Alternative approaches are described in ISO 19030-3:2016, 5.4.2.

For the correction for wind resistance (as detailed in [Annex G](#)) and the true wind speed and direction (as detailed in [Annex E](#)), the following quantities are needed for one reference condition (typically design condition):

- transverse projected area of windage area and height of its (estimated) centroid above water level;
- wind resistance coefficients based on transverse projected area;
- anemometer height above sea level at reference condition (typically design condition).

As basis for the correction, wind resistance coefficients from wind tunnel tests of the vessel in question shall be used. If these are not available, wind resistance coefficients for the vessel type in question shall be used following ISO 15016.

Ship width is needed for wind correction and in the filtering for reference conditions.

5 Measurement procedures

5.1 General

This clause discusses how measurement data are to be acquired, stored and prepared.

5.2 Data acquisition

Data shall be automatically and continuously collected by the data acquisition system (e.g. a data logger) as follows in [Table 2](#).

Table 2 — Minimum data acquisition rates

	Parameter	Minimum data acquisition rate
Primary parameters	Vessel speed through water	Once every 15 s (0,07 Hz)
	Delivered power ^a	Same as for vessel speed and same time stamp as vessel speed
Secondary parameters	Shaft revolutions	Once every 15 s (0,07 Hz)
	Relative wind speed/direction	Once every 15 s (0,07 Hz)
	Speed over ground and ship heading	Once every 15 s (0,07 Hz)
	Rudder angle	Once every 15 s (0,07 Hz)
	Water depth	Once every 15 s (0,07 Hz)
	Static draught fore and aft	Whenever loading condition changes
	Water temperature	Once every 15 s (0,07 Hz)
^a The sensor measurements needed to estimate delivered power by either Annex B or Annex C shall be logged at the minimum acquisition rate for the primary parameters and with the same time stamp.		

The data sampling rate shall remain unchanged over the full measurement period (reference period and evaluation period).

NOTE Over short periods of time, the data sampling rate may coincide with the frequency of a natural phenomenon for the vessel in question (e.g. wave encounter frequency) and thereby influencing the accuracy of associated data point.

5.3 Data storage

All data collected over the measurement period shall be stored in the data acquisition system. All data shall be stored as raw data along with time stamps as time offsets from universal time coordinated (UTC)²⁾ indicating the point in time the data were collected.

It is recommended that data shall be backed up at an appropriate backup facility at a minimum of once every month. If the data acquisition system is kept on board the vessel, it is recommended that the backup facility is located elsewhere.

At any one time it shall be possible for the owner of the data to retrieve all data stored in the data acquisition system or at the backup facility as raw data along with the time stamps. The data shall be retrievable in a commonly used electronic format.

It is recommended that all collected data be stored in the data acquisition system and/or at the backup facility at least over the remaining life of the ship in question or as determined by the use of the standard.

NOTE [Annex H](#) recommends a format of exporting stored data.

5.4 Data preparation

5.4.1 General

Data preparation involves retrieving, compiling, filtering and validating collected data in order to provide a structure, format and quality that is suitable for further processing and in order to enable corrective measures if the collected data are found to be invalid (e.g. on account of sensor drift). It furthermore comprises the calculation of performance values (PVs) used in subsequent calculation of performance indicators (PIs).

2) UTC being defined by ISO 8601: “YYYY-MM-DDTHH:MM:SS±hh”

5.4.2 Data preparation frequency

Data shall be prepared regularly, in order to enable timely corrective measures (e.g. sensor recalibration).

It is recommended that the data are prepared at least once every month.

5.4.3 Data retrieval

Collected data should be retrieved such that a copy of the originally stored raw data is left on the data acquisition system or at the backup facility (copy not deleted). This shall ensure that a copy of the originally stored raw data will always remain available.

5.4.4 Data compilation

5.4.4.1 General

The data shall be compiled into a tabular format and sorted sequentially based on the time stamp of the primary measurement parameter data. The time stamp of the primary parameter data shall serve as unique identifier (UI).

5.4.4.2 Data preparation for data from different sampling rates

Data collected at a higher frequency than the primary measurement parameters shall be averaged over the relevant time interval. High-frequency data collected between two successive lower-frequency measurements of primary parameters shall be averaged as given in [Formula \(2\)](#):

$$a_{i+f^{-1}} = \frac{1}{n_k} \sum_1^{n_k} m_k \quad \text{for } i < k \leq i + f^{-1} \quad (2)$$

All high-frequency measurement values, m_k , with time stamp k , shall be averaged into an average value a if k is between the primary measurement parameter time stamp i and the subsequent time stamp $i + f^{-1}$ where f is the frequency at which the primary measurement parameters are collected (e.g. 1 signal every 15 s). The number of high-frequency measurement values in the so defined time interval is given by n_k .

Data from signals collected at a lower frequency than the primary measurement parameters shall be duplicated over the relevant time interval. The low-frequency measurement value, m_k , with time stamp k , shall be duplicated in values a_i with time stamps i from the higher frequency, primary measurement parameters, where i lies between k and the foregoing time stamp $k - t^{-1}$ [see [Formula \(3\)](#)]. t is the frequency at which the lower frequency measurement parameter is collected.

$$a_i = m_k \quad \text{for all } i \text{ in } k - t^{-1} < i \leq k \quad (3)$$

5.4.4.3 Additional data preparation for twin screw vessels

In case of twin screw vessels, the arithmetic mean of the rpm and the sum of the delivered power of the port and starboard shafts shall be computed and added to the data set.

5.4.4.4 “Data point” and “retrieved data set”

The combination of a unique identifier (UI) and a complete set of data from all signals shall be referred to as a “data point”. The complete set of retrieved data points shall be referred to as the “retrieved data set”.

5.4.5 Data filtering and validation

In the retrieved data set, outliers and missing values shall be marked invalid. To this end in consecutive, non-overlapping blocks spanning 10 min, data for every parameter shall be filtered according to Chauvenet's criterion (see [Annex I](#)). If the data for one parameter is identified as an outlier, the complete data point shall be marked as invalid. If data for one or more parameters is missing for a data point, this data point shall be marked as invalid.

Furthermore, the data set shall be split in non-overlapping, consecutive blocks of 10 min and for every block of 10 min, the mean, the standard deviation, the maximum and the minimum value for every parameter shall be computed. This blocked data set shall be used in the validation procedures (see [Annex J](#)) and all data points for invalid blocks with data shall be marked as invalid.

The data set where all invalid data are excluded shall be referred to as the "validated data set".

NOTE It is noted that 10 min data blocks can be useful for analysis.

5.4.6 Correction for environmental factors

The delivered power entries for the data points of the validated data set are corrected for wind resistance. The wind correction shall be computed following [Annex G](#). For twin screw vessels, the sum of delivered power for starboard and port shafts shall be corrected for wind resistance.

NOTE Wave correction will be considered in future revisions of this document to further align with relevant standards, e.g. ISO 15016.

The new data set is referred to as the "corrected data set".

5.4.7 Calculation of performance values (PVs)

5.4.7.1 General

A PV shall be calculated for every data point in the corrected data set. The union of the corrected data set and the PVs is referred to as the "prepared data set".

The PV is defined as the percentage speed loss compared with a reference speed-power relation.

5.4.7.2 Percentage speed loss

The percentage speed loss, V_d [see [Formula \(4\)](#)], is calculated as the relative difference in percent between the measured vessel speed through water, V_m , and an expected speed through water, V_e .

$$V_d = 100 \cdot \frac{V_m - V_e}{V_e} \quad (4)$$

5.4.7.3 Expected speed

The expected speed through water is read from a speed-power reference curve at the corrected delivered power and at the measured displacement and trim. The origin of the speed-power reference curves is defined in [4.5](#) and the same set of speed-power reference curves have to be used in the reference and the evaluation periods. The displacement for a given draught and trim is to be read from the displacement tables of the vessel in question. The displacement shall be computed from static draught and trim.

6 Calculation of performance indicators (PIs)

6.1 General

This clause discusses how the four PIs defined in ISO 19030-1 shall be calculated based on PVs extracted from a prepared data set.

NOTE PIs are dimensioned in terms of speed. A method for calculating PIs dimensioned in terms of power is provided in [Annex K](#).

6.2 Definition of PIs

Measurements of ship-specific changes in hull and propeller performance can be used to determine the effectiveness of hull and propeller maintenance, repair and retrofit activities. [Table 3](#) summarizes the four PIs, defined in ISO 19030-1.

Table 3 — Basic hull and propeller performance indicators (PIs)

Performance indicators (PI)	Definition
Dry-docking performance: Determining the effectiveness of the dry-docking (“re-pair” and/or retrofit activities)	Change in hull and propeller performance following present out-docking (evaluation period) as compared with the average from previous out-dockings (reference periods).
In-service performance: Determine the effectiveness of the underwater hull and propeller solution (including any maintenance activities that have occurred over the course of the full dry-docking interval)	Average change in hull and propeller performance from a period following out-docking (reference period) to the end of dry-docking interval (evaluation period).
Maintenance trigger: Trigger underwater hull and propeller maintenance, including propeller and/or hull inspection	Change in hull and propeller performance from the start of the dry-docking interval (reference period) to a moving average at a given point in time (evaluation period).
Maintenance effect: Determine the effectiveness of a specific maintenance event, including any propeller and/or hull cleaning	Change in hull and propeller performance from before (reference period) to after a maintenance event (evaluation period).

6.3 Calculation of PIs

6.3.1 General

The following steps apply for the calculation of each PI:

- determination of reference conditions;
- establishment of reference period and evaluation period;
- extraction of subsets of PVs from the complete set with PVs that fulfil reference conditions for reference period and evaluation period;
- calculation of the PI;
- assessing the accuracy of the PI.

6.3.2 Determination of reference conditions

The reference conditions are the same for all PIs and they are met when, simultaneously:

- water temperature is above +2 °C³⁾ and if there is no other indication that the vessel is trading in ice;
- the true wind speed is between 0 m/s and 7,9 m/s (BF 0 and BF 4);
- water depth is greater than the larger of the values obtained from [Formulae \(5\)](#) and [\(6\)](#):

$$h = 3\sqrt{B \cdot T_M} \quad (5)$$

$$h = 2,75 \frac{V_s^2}{g} \quad (6)$$

where

h is the water depth (m);

B is the ship breadth (m);

T_M is the draught at midship or mean draught (m);

V_s is the ship speed (m/s);

g is the gravitational acceleration (9,806 65 m/s²).

NOTE 1 If the water depths values are out-of-range of the water depth sensor measurement range, this condition cannot be applied.

- Delivered power has to be within the range of power values covered by the available speed-power reference curves.

For twin screw vessels, the sum of delivered power for starboard and port shafts shall be considered:

- displacement has to be within ±5 % of the displacement values for the available speed-power reference curves;
- absolute rudder angle value is smaller than 5°;
- in case that delivered power is estimated by the method outlined in [Annex C](#), the estimated delivered power has to be within the range of power values covered by the available SFOC reference curve.

NOTE 2 If vessel motion measurements are available, these can be used to filter the data further to increase accuracy.

6.3.3 Establishment of reference period and evaluation period

6.3.3.1 General

NOTE Data are filtered and the reference and evaluation periods might therefore be discontinuous.

6.3.3.2 Dry-docking performance

The period following directly after the latest dry-docking is the evaluation period. The period(s) following directly after the previous dry-docking(s) are the reference period(s). All periods are to be of the same length of 1 year.

3) The filter criterion is included to exclude situations where the vessel is trading in ice.

6.3.3.3 In-service performance

The period following directly after the latest dry-docking is the reference period. The period following the reference period until the end of same dry-docking period is the evaluation period. The reference period and the evaluation period shall both be of minimum 1 year.

6.3.3.4 For the maintenance trigger

The period following directly after the latest dry-docking is the reference period. A period after the reference period in the same dry-docking interval is the evaluation period. The reference period and the evaluation period shall both be a minimum of 3 months.

The uncertainty analysis in ISO 19030-1:2016, Annex A is carried out by assuming that approximately 70 % of the observations are discarded through the application of the filtering criterion. In exceptional circumstances, it is possible that filtering removes more than this quantity of data. There is no minimum threshold for the number of filtered samples; however, if filtering removes more than 75 % of the observations, the respective uncertainty quantifications should be seen as lower bound indicative values only. The risk of higher uncertainty should be factored into any further deployment of the analysed data and a note should be added to the analysed data to this effect.

6.3.3.5 For the maintenance effect

The period following directly the maintenance event is the evaluation period. The period preceding the event is the reference period. The reference period and the evaluation period shall both be a minimum of 3 months.

6.3.4 Extraction of subsets of PVs from the complete set with PVs that fulfil reference conditions for reference period(s) and evaluation period

The data points corresponding to reference conditions shall be extracted from the processed data set for the reference period(s) and the evaluation period. The new data set is referred to as the processed data set under reference conditions.

6.3.5 Calculation of the PI

6.3.5.1 Calculation of average percentage speed loss over the reference period(s)

The average percentage speed loss over the reference period(s) shall be calculated using [Formula \(7\)](#):

$$\bar{V}_{d,ref} = \frac{1}{k} \sum_j^k \frac{1}{n} \sum_i^n V_{d,j,i} \quad (7)$$

where

- k is the number of reference periods;
- j is the reference period counter;
- n is the number of data points in the processed data set under reference conditions in the reference period j ;
- i is the counter of data points in reference period j ;
- $V_{d,j,i}$ is the percentage speed loss for data point i in reference period j ;
- $\bar{V}_{d,ref}$ is the average percentage speed loss over the reference period(s).

6.3.5.2 Calculation of average percentage speed loss over the evaluation period

For the evaluation period data set, the average percentage speed loss over the evaluation period, $\bar{V}_{d,eval}$, shall be calculated using [Formula \(8\)](#):

$$\bar{V}_{d,eval} = \frac{1}{n} \sum_i^n V_{d,eval,i} \quad (8)$$

where

n is the number of data points in the processed data set under reference conditions of the evaluation period;

$V_{d,eval,i}$ is the percentage speed loss for data point i in a data set of the evaluation period;

$\bar{V}_{d,eval}$ is the average percentage speed loss in data set of the evaluation period.

6.3.5.3 Calculation of the differences between the average percentage speed loss of the reference period and the evaluation period

The change in the average speed loss in the reference period(s) and the average speed loss in the evaluation period is defined as PI and is calculated according to [Formula \(9\)](#):

$$k_{HP} = \bar{V}_{d,eval} - \bar{V}_{d,ref} \quad (9)$$

where

$\bar{V}_{d,eval}$ is the average percentage speed loss in data set of the evaluation period;

$\bar{V}_{d,ref}$ is the average percentage speed loss over the reference period(s).

7 Accuracy of PIs

7.1 General

Appropriate use of PIs for decision-making purposes is dependent on understanding to what extent uncertainty influences the accuracy of each PI.

7.2 Guidance on the expected accuracy of PIs

In [Table 4](#), the accuracy of each PI has been estimated in order to offer guidance on what accuracy can be achieved given that all requirements of this document are met.

NOTE 1 The uncertainty quantifications are calculated from the simulation defined in ISO 19030-1:2016, A.7. The simulation parameters and assumptions are considered to be representative for the ship types and sizes for which this document is intended. However, the technical and operational specifics of an individual ship could create significant differences in the absolute and relative uncertainties of the different part's measurement methods. Consequently, it is advised that when using these uncertainty quantifications, careful attention is paid to ensure the applicability of the key assumptions and that the quantifications are treated as indicative values only.

NOTE 2 ISO 19030-1:2016, Annex A estimates different uncertainties for each of the methods in [Annexes B](#) and [C](#). Because the differences in PV uncertainty are small, and to provide simple guidance to the user, a single value of uncertainty for both [Annexes B](#) and [C](#) has been defined. This is a pragmatic solution to the challenge of describing a single representative value for each of the methods in [Annexes B](#) and [C](#). As shown in ISO 19030-1:2016, Annex A, the lowest levels of uncertainty are achieved using [Annex B](#).

NOTE 3 The relative importance of the different resistance components varies to a certain degree with the operational and environmental condition the vessel is exposed to. Also, the accuracy of the models to correct/normalize for such variations depends on the operational and environmental conditions. These dependencies impact the accuracy of the hull and propeller performance indicators as described in the current standard. Therefore, in the estimation of the accuracy of the performance indicators and for the intended usage, comparable operational and environmental conditions over the reference and evaluation period (see ISO 19030-1:2016, Annex A) are assumed. Future revisions of this document will re-evaluate if more accurate correction formulae are available that take the above mentioned dependencies into consideration.

Table 4 — Guidance on the expected accuracy of performance indicators (PIs)

Performance indicator (PI)	Estimated uncertainty, to within a 95 % confidence interval, associated with the estimated PI values (in percentage points)
Dry-docking performance: Determining the effectiveness of the dry-docking (repair and/or retrofit activities)	±0,3 % ^a
In-service performance: Determine the effectiveness of the underwater hull and propeller solution (including any maintenance activities that have occurred over the course of the full dry-docking interval)	±0,3 % ^b
Maintenance trigger: Trigger underwater hull and propeller maintenance, including propeller and/or hull inspection	±0,5 %
Maintenance effect: Determine the effectiveness of a specific maintenance event, including any propeller and/or hull cleaning	±0,5 %
^a Assuming one reference period. ^b Assuming 1-year evaluation period/2-year dry-docking interval.	

Annex A (informative)

Process of this document

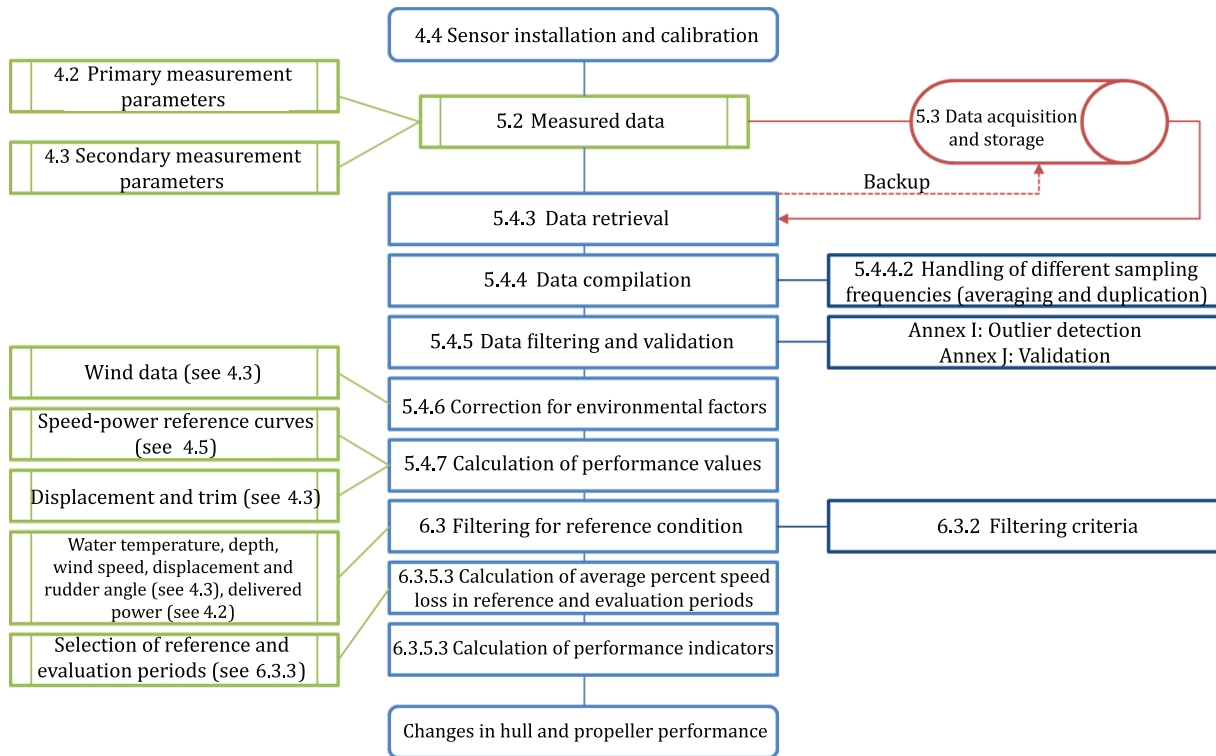

Annex B (normative)

Approximating delivered power based on calculations of shaft power

Delivered power shall be approximated based on calculations of shaft power, P_s , from continuous measurements of shaft torque and shaft revolutions and based on [Formula \(B.1\)](#):

$$P_s [\text{kW}] = Q_s [\text{kNm}] \cdot 2\pi/60 \cdot n_s [\text{rev/min}] \quad (\text{B.1})$$

where

Q_s is the shaft torque;

n_s is the shaft revolutions.

The following sensors with the following minimum sensor requirements shall be used (see [Table B.1](#)).

Table B.1 — Minimum sensor requirements, shaft power approach

Measurement	Acceptable measurement device ^a	Unit
Shaft torque (Q_s)	Torsion meter: — minimum sensor accuracy for torque of $\pm 0,5\%$ (1σ)	kNm
Shaft revolutions (n_s)	Pick-up, optical sensor, ship revs counter — minimum sensor accuracy of $\pm 0,5\%$ (1σ)	rev/min

^a Minimum sensor accuracy refers to the sensor manufacturer's specified accuracy.

The measurements of shaft torque and shaft revolutions shall be conducted and made available for collection by the data acquisition system, in accordance with the data sampling rate requirements specified under [5.2](#).

For vessels with twin screws, shaft torque and shaft revolutions shall be measured on both shafts.

It is recommended to use the same sensor type on both shafts.

Shaft power shall be calculated for both shafts from the respective measured shaft torque and shaft revolutions following [Formula \(B.1\)](#) and be used as approximation to the delivered power at the starboard and port propeller, respectively.

The following conditions shall be met for this annex to be applicable:

- shaft torque and shaft revolutions shall be measured after bearings as seen from main engine;
- in line with class requirements, the shaft line, including bearings, shall be sufficiently well maintained to ensure transmission efficiency (shaft power vs. delivered power) remains unchanged throughout the reference and evaluation periods.

Annex C (normative)

Approximating delivered power based on calculations of brake power

If a torque meter with required signal quality is not available and if conditions listed below are fulfilled, delivered power shall be approximated based on calculations of brake power, P_B ⁴⁾, from an engine-specific SFOC reference curve defined in [Annex D](#), continuous measurements of fuel flow and temperature and bunker analysis data [calorific value, density and density change rate for the fuel being consumed; see [Formula \(C.1\)](#)]:

$$P_B = f \left(M_{\text{FOC}} \times \frac{\text{LCV}}{42,7} \right) \quad (\text{C.1})$$

where

M_{FOC} is the mass of consumed fuel oil by main engine (kg/h);

LCV is the lower calorific value of fuel oil (MJ/kg);

f is the SFOC reference curve.

Mass of consumed fuel can be obtained from a mass flow meter or a volume flow meter. In the event that mass of consumed fuel oil is obtained from a volume flow meter, mass of fuel oil shall be calculated from volume (V_{FOC}) and temperature (T_{FO}) of consumed fuel oil [see [Formula \(C.2\)](#)]:

$$M_{\text{FOC}} = V_{\text{FOC}} \times \left[\rho_{\text{FO}} - \alpha_T \times (T_{\text{FO}} - 15) \right] \quad (\text{C.2})$$

where

V_{FOC} is the volume of consumed fuel oil per unit time (l/h);

ρ_{FO} is the density of fuel oil at 15 °C (kg/l);

α_T is the density change rate per 1 °C temperature change of fuel oil (kg/l);

T_{FO} is the temperature of fuel oil at flow meter inlet (°C).

The SFOC reference curve shall be based on actual shop tests of the specific engine in question, shall cover all relevant engine output ranges and shall be corrected for environmental factors as per ISO 3046-1 and for a normal fuel of 42 700 kJ/kg.

The following sensors with the following minimum sensor requirements shall be used (see [Table C.1](#)).

4) In case of twin screw vessels, the calculation of brake power shall be done for both engines.

Table C.1 — Minimum sensor requirements, brake power approach

Measurement	Acceptable measurement device ^a	Unit
Mass or volume of consumed fuel per unit time for main engine (M_{FOC} or V_{FOC})	Flow meter — minimum sensor accuracy of $\pm 0,5$ % for the full working range	kg/h or l/h
Temperature of fuel at flow meter inlet (T_{FO})	Thermometer — minimum sensor accuracy of $\pm(0,3 + 0,005t)$ %, where t is °C	°C

^a Minimum sensor accuracy refers to the sensor manufacturer's specified accuracy.

The measurements of V_{FOC} and T_{FO} shall be conducted and made available for collection by the data acquisition system, in accordance with the data sampling rate requirements specified under 5.2.

Any change in fuel being consumed by the main engine that will cause a change to the calorific value and/or density shall either be automatically or manually entered into the data set so that the time of the change is clearly defined and the new values are available for calculating M_{FOC} .

New data points shall be recorded when changing from one batch of fuel to another batch of fuel or when changing from residual fuels to distillate fuels.

In addition, for the fuel consumed at any given point in time, the following bunker analysis report data shall be available (see Table C.2).

Table C.2 — Bunker data requirements, brake power approach

Bunker data	Acceptable source	Unit
Lower calorific value of fuel oil (LCV)	Bunker delivery ^a	MJ/kg
Density of fuel oil at 15 °C (ρ_{FO})	Bunker delivery ^a	kg/l
Density change rate per 1 °C temperature change of fuel oil (α_T)	ASTM Table 54B and 56 or equivalent	kg/l/°C

^a Bunker analysis reports and/or equivalent.

The SFOC correction shall be done according to ISO 3046-1. The data used for the corrections shall be automatically collected and obtained from suitable sensors.

The following conditions shall be met for this annex to be applicable:

- This annex is only applicable on single or twin screw vessels with direct drive propulsion system and is neither applicable on LNG fueled vessels nor dual fuel vessels.
- This annex is not applicable on vessels with shaft generators and/or on vessels where auxiliary power can be taken off the shaft and/or the main engine.
- This annex is not applicable in the event of:
 - changes in maximum continuous rating (MCR) of engine;
 - changes in components in the Technical File which is normally produced by the engine manufacturer and approved by the Administration in accordance with 2.4.1.1 of 2008 NOx Technical File (NTC);

- changes in settings out of allowable range in the Technical File which is normally produced by the engine manufacturer and approved by the Administration in accordance with 2.4.1.2 of 2008 NTC.
- Fuel flow meter(s) shall be placed in such a way so as to exclusively measure the mass/volume actually combusted by the main engine.
 - The back wash drain from the fuel oil filter before the main engine shall be recorded and deducted from the consumed fuel oil.
 - With semi-mono fuel system [with separate circulation line for main engine and aux. engine(s) respectively], one set of flow meters shall be provided on fuel/diesel oil supply line for main engine [after branch-off to aux. engine(s)].
 - With mono fuel system [with common circulation line for main engine and aux. engine(s)], flow meters shall be provided as follows:
 - one set on common fuel oil supply line for main engine and aux. engine(s) (M_{FOC-1});
 - one set on fuel oil supply line for aux. engine(s) (M_{FOC-2});
 - one set on fuel oil return line for aux. engine(s) (M_{FOC-3});
 - in this case, temperature of fuel should be measured at each flow meter inlet and M_{FOC-1} to M_{FOC-3} should be separately obtained from the [Formula \(C.2\)](#);
 - fuel oil consumption for main engine shall then be calculated as $M_{FOC} = M_{FOC-1} - M_{FOC-2} + M_{FOC-3}$.
- In line with the Classification Societies requirements:
 - The main engine shall be maintained continuously and in accordance with engine manufacturer's recommendation in order to ensure engine efficiency remains unchanged throughout the reference and evaluation periods. Service hours of wearing parts (replaced parts) after replacement shall be within the engine manufacturer's recommendation and cleaning intervals of the turbocharger and inter-cooler shall be strictly kept.
 - Main engine performance shall be continuously monitored and sufficient records shall be kept in order to allow verification that engine efficiency does not change throughout the reference and evaluation periods.
 - Shaft line, including bearings, shall be sufficiently well maintained in order to ensure transmission efficiency remains unchanged throughout the reference and evaluation periods.

NOTE Different distributions of draft/trim conditions across the evaluation and reference periods and/or a large variability in SFOC for an envelope of propeller curves covering the typical operation range of the specific vessel in question will increase the uncertainty when approximating delivered power based on calculations of brake power.

Annex D (informative)

SFOC reference curve

This annex shows how to approximate [Formula \(C.1\)](#).

In the shop trial report for the main engine, brake power (kW) and subsequent fuel oil consumption (kg/h) are given at different rated engine loads. The SFOC reference curve shall be approximated at least as a parabolic function. The curve shall not be used to extrapolate below the lowest load given in the shop trial report. The type of approximation shall be documented.

An example is given in [Table D.1](#) and in [Figure D.1](#).

Table D.1 — Shop trial report for the main engine (Example)

Load	%	25	50	75	85	100
Brake power (P_B)	kW	2,584	5,170	7,759	8,791	10,338
Specific fuel oil consumption (SFOC) ^{a, b}	g/kWh	167,2	161,8	162,1	162,9	165,6
Fuel oil consumption ^c $\left(M_{FOC} \times \frac{LCV}{42,7} \right)$	kg/h	432	837	1,258	1,432	1,712
^a LCV corrected to 42,7 MJ/kg. ^b SFOC corrected to ISO reference condition. ^c Fuel oil consumption = Brake power × SFOC/1000.						

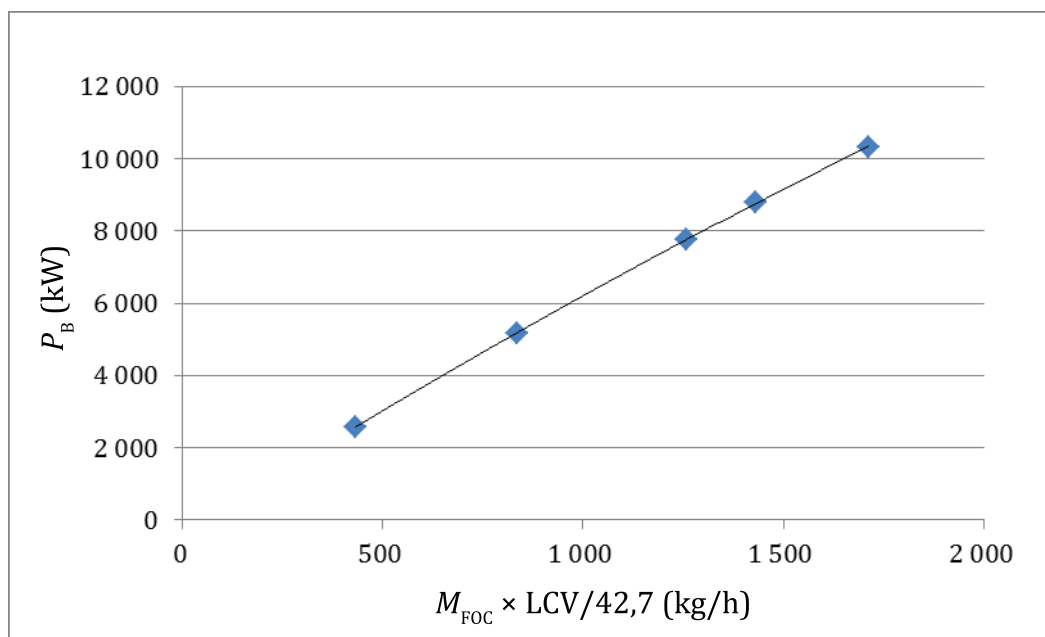

$$P_B = -4,3963 \times 10^{-4} \times \left(M_{\text{FOC}} \times \frac{\text{LCV}}{42,7} \right)^2 + 7,0150 \times \left(M_{\text{FOC}} \times \frac{\text{LCV}}{42,7} \right) - 3,7205 \times 10^2$$

Figure D.1 — SFOC reference curve (Example)

Annex E (normative)

Calculation of true wind speed and direction

True wind velocity, v_{wt} (m/s), and true wind direction, ψ_{wt} ($^{\circ}$), at height of the anemometer is computed from the relative wind velocity, v_{wr} (m/s), the vessel speed over ground, v_g (m/s), the direction of the relative wind, ψ_{wr} ($^{\circ}$), and the vessel heading, ψ_0 ($^{\circ}$), according to [Formulae \(E.1\)](#) and [\(E.2\)](#):

$$v_{wt} = \sqrt{v_{wr}^2 + v_g^2 - 2v_{wr} \cdot v_g \cdot \cos \psi_{wr}} \quad (\text{E.1})$$

$$\psi_{wt} = \tan^{-1} \left\{ \begin{array}{l} \frac{v_{wr} \cdot \sin(\psi_{wr} + \psi_0) - v_g \sin(\psi_0)}{v_{wr} \cos(\psi_{wr} + \psi_0) - v_g \cos(\psi_0)} \\ \frac{v_{wr} \cdot \sin(\psi_{wr} + \psi_0) - v_g \sin(\psi_0)}{v_{wr} \cos(\psi_{wr} + \psi_0) - v_g \cos(\psi_0)} \end{array} \right\} \quad \left. \begin{array}{l} \text{for } v_{wr} \cos(\psi_{wr} + \psi_0) - v_g \cos(\psi_0) \geq 0 \\ \text{for } v_{wr} \cos(\psi_{wr} + \psi_0) - v_g \cos(\psi_0) < 0 \end{array} \right\} \quad (\text{E.2})$$

[Figure E.1](#) illustrates the sign conventions for directions relative to the vessel heading.

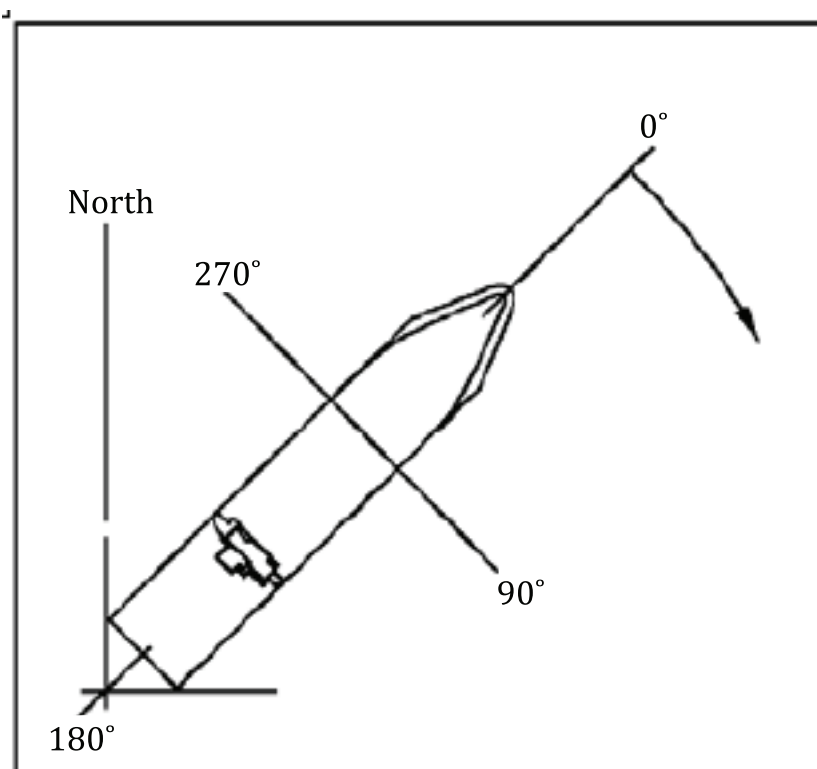

Figure E.1 — Sign conventions

[Figure E.2](#) illustrates the true and relative wind speed, the vessel speed over ground, the relative and true wind direction and vessel heading.

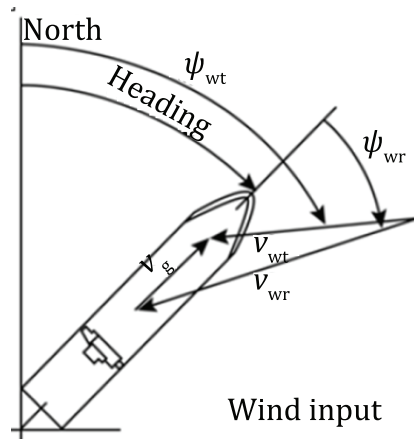

Figure E.2 — Calculation of true wind speed and direction at reference height

To calculate the wind resistance, the wind speed and the direction at the reference height of the wind tunnel tests, on which the wind resistance coefficients are based, shall be used. Therefore, the wind velocity and the direction at anemometer height shall be corrected to those at the reference height.

If a reference height of wind tunnel tests is not available, a reference height of 10 m shall be chosen. The difference between the height of the anemometer and the reference height for the wind resistance is to be corrected by means of the wind velocity profile using [Formula \(E.3\)](#):

$$v_{wt,ref} = v_{wt} \left(\frac{Z_{ref}}{Z_a} \right)^{1/7} \quad (E.3)$$

where

- $v_{wt,ref}$ is the true wind velocity at reference height in m/s;
- v_{wt} is the true wind velocity at anemometer height in m/s;
- Z_{ref} is the reference height above current sea level in m;
- Z_a is the anemometer height above current sea level in m.

The relative wind velocity at reference height above current sea level is calculated using [Formula \(E.4\)](#):

$$v_{wr,ref} = \sqrt{v_{wt,ref}^2 + v_g^2 + 2v_{wt,ref}v_g \cos(\psi_{wt} - \psi_0)} \quad (E.4)$$

The relative wind direction at reference height above current sea level, in degrees, is calculated using [Formula \(E.5\)](#):

$$\left. \begin{aligned} \psi_{wr,ref} &= \tan^{-1} \left\{ \frac{v_{wt,ref} \sin(\psi_{wt} - \psi_0)}{v_g + v_{wt,ref} \cos(\psi_{wt} - \psi_0)} \right\} && \text{for } v_g + v_{wt,ref} \cos(\psi_{wt} - \psi_0) \geq 0 \\ \psi_{wr,ref} &= \tan^{-1} \left\{ \frac{v_{wt,ref} \sin(\psi_{wt} - \psi_0)}{v_g + v_{wt,ref} \cos(\psi_{wt} - \psi_0)} \right\} + 180 && \text{for } v_g + v_{wt,ref} \cos(\psi_{wt} - \psi_0) < 0 \end{aligned} \right\} \quad (E.5)$$

The heights above current sea level depend on the current loading condition, in particular on the current draught. Wind resistance coefficients are generally given for one reference condition, typically design loading condition.

Heights are converted to current sea level as follows, assuming negligible effect of trim:

$$\Delta T = T_{\text{ref}} - T \quad (\text{E.6})$$

$$A = A_{\text{ref}} + \Delta T \cdot B \quad (\text{E.7})$$

$$Z_{\text{a}} = Z_{\text{a,ref}} + \Delta T \quad (\text{E.8})$$

$$Z_{\text{ref}} = \frac{A_{\text{ref}} \cdot (Z_{\text{ref,ref}} + \Delta T) + \frac{1}{2} B \cdot \Delta T^2}{A} \quad (\text{E.9})$$

where

- ΔT is the difference between design draught and current draught, in m;
- T_{ref} is the design draught, in m;
- T is the current draught, in m;
- A_{ref} is the transverse projected area in design condition, in m²;
- B is the ship width, in m;
- $Z_{\text{a,ref}}$ is the anemometer height above sea level for design condition, in m;
- $Z_{\text{ref,ref}}$ is the reference height above sea level for design condition, in m.

See [Annex G](#) for computation of A_{ref} .

The expression for wind direction reverses numerator and denominator compared with Formula (D.10) in MEPC[3]. A simple test case is head wind which shall again give head wind as relative wind direction.

Annex F **(informative)**

Procedure to obtain ship specific power-speed-draught-trim databases

Power-speed-draught-trim databases express the required power as a function of speed, draught and trim. They may be based on model tests, sea trials or computational fluid dynamics (CFD).

In any case, the approach chosen shall:

- be documented;
- follow generally accepted state-of-the-art procedures, e.g. those recommended by International Towing Tank Conference (ITTC) or ISO 15016;
- consider the ship in propulsion condition;
- cover the complete relevant range of input parameters (speed, draught, trim) with sufficient density to keep interpolation errors for the power below 2 %. This shall be verified by omitting data points in the interpolation and comparing interpolated and actual values for these data points;
- calibrate results against sea trials.

If a CFD approach is employed, the approach shall:

- be able to capture breaking waves. Otherwise larger errors are to be expected at intermediate draught conditions with partially submerging bulbous bows;
- have been validated for simulations of ship flows with working propeller and free to trim and sink (“numerical propulsion tests”). Full-scale simulations are preferable.

Annex G (normative)

Correction for wind resistance

Delivered power entries, P_D , are to be corrected for wind resistance by subtracting the wind resistance correction, ΔP_W , following [Formula \(G.1\)](#):

$$P_{D,corr} = P_D - \Delta P_W \quad (G.1)$$

where

$P_{D,corr}$ are the corrected delivered power entries.

As basis for the correction, wind resistance coefficients from wind tunnel tests of the vessel in question shall be used. If these are not available, wind resistance coefficients for the vessel type in question shall be used following ISO 15016.

The wind resistance correction shall be computed following [Formula \(G.2\)](#):

$$\Delta P_W = \frac{(R_{rw} - R_{0w}) \cdot v_g}{\eta_{D0}} + P_D \left(1 - \frac{\eta_{DM}}{\eta_{D0}} \right) \quad (G.2)$$

where

$$R_{rw} = \frac{1}{2} \cdot \rho_a \cdot v_{wr}^2 \cdot A \cdot C_{rw}(\psi_{wr,ref})$$

and

$$R_{0w} = \frac{1}{2} \cdot \rho_a \cdot v_g^2 \cdot A \cdot C_{0w}(0)$$

where

ΔP_W is the wind correction in W;

R_{rw} is the wind resistance due to relative wind in N;

R_{0w} is the air resistance in no-wind condition in N;

v_g is the ship speed over ground in m/s;

v_{wr} is the relative wind speed at reference height in m/s;

C_{rw} is the wind resistance coefficient, dependent on wind direction of relative wind $\psi_{wr,ref}$ [-];

C_{0w} is the wind resistance coefficient for head wind (0° wind direction) [-];

ρ_a is the air density in kg/m³;

A is the transverse projected area in current loading condition in m²;

$\psi_{wr,ref}$ is the relative wind direction at the reference height (0 for head winds, 90° for wind from a beam) in °;

η_{D0} is the propulsive efficiency coefficient in calm condition [-];

η_{DM} is the propulsive efficiency coefficient in actual voyage condition [-].

Calculation methods for the propulsive efficiency coefficients are described in ISO 15016:2015, Annexes K and J. If the propulsive efficiency coefficients are not available, they shall be set to 0,7. The same approach in handling the propulsive efficiency coefficients shall be used in the reference and evaluation period.

Different sign conventions are used for wind resistance coefficients. Care should be taken that wind resistance coefficients follow the definition in this document.

The exposed areas above current sea level depend on the current loading condition, in particular on the current draught. Wind resistance coefficients are generally given for design loading condition.

The transverse projected area in current loading condition is approximated using [Formulae \(G.3\)](#) and [\(G.4\)](#):

$$\Delta T = T_{ref} - T \quad (G.3)$$

$$A = A_{ref} + \Delta T \cdot B \quad (G.4)$$

where

ΔT is the difference between design draught and current draught, in m;

T_{ref} is the design draught, in m;

T is the current draught, in m;

A_{ref} is the transverse projected area in design condition, in m²;

B is the ship width, in m.

Air density shall be estimated from air temperature and air pressure using [Formula \(G.5\)](#):

$$\rho_a = \frac{p}{R \cdot (T_{air} + 273,15)} \quad (G.5)$$

where

ρ_a is the air density in kg/m³;

p is the air pressure in Pa;

R is the specific gas constant (287,058 J/kg/K);

T_{air} is the air temperature in °C.

Annex H (informative)

Protocol to export data from data logger

This annex provides a CSV format protocol by which to export data from a data logger for the four data sets. The delimiter between parameters shall be a comma.

The FIRST line of the CSV file shall describe what data set type is being presented as per the following:

- 1_RETRIEVED_DATASET
- 2_VALIDATED_DATASET
- 3_CORRECTED_DATASET
- 4_PREPARED_DATASET

The SECOND line of the CSV file shall describe the method used to calculate delivered power as per the following:

- ANNEX_B_SHAFT_POWER
- ANNEX_C_BRAKE_POWER

The THIRD line of the CSV file shall describe the specific fields that are being presented in the file.

The FOURTH line of the CSV file shall be the first data point in the data set, with each following data point on a new line.

Each field is to be presented as per [Table H.1](#) based on the Application column:

- Fields marked “X” shall be displayed. For the 1_RETRIEVED_DATASET, any fields with a missing value shall be represented as NULL by simply showing no data (e.g. in “2014-08-22T16:32:37+00,7.3,,1182.17” the ,, illustrates no data are available for that entry).
- Fields marked “O” are OPTIONAL; however, the THIRD line of the CSV file shall announce whether or not this field is present and all data points shall be presented consistently.
- Fields left blank shall not be displayed.

Table H.1 — Presentation of fields

Parameter	Units	Format	Comments	Application							
				ANNEX_B_SHAFT_POWER				ANNEX_C_BRAKE_POWER			
				1_RE- TRIEVED_ DATASET	2_VALIDATED_ DATASET	3_COR- RECTED_ DATASET	4_PRE- PARED_ DATASET	1_RE- TRIEVED_ DATASET	2_VAL- IDAT- ED_DA- TASET	3_COR- RECTED_ DATASET	4_PRE- PARED_ DATASET
Unique identifier	YYYY-MM-DDTHH:MM:SS±hh		in UTC	X	X	X	X	X	X	X	X
Speed through water	knots	00,0		X	X	X	X	X	X	X	X
ME power	kW	000000		X	X	X	X	X	X	X	X
ME shaft torque	kNm	0000		X	X	X	X	X	X	X	X
ME shaft speed	rev/min	000,0		X	X	X	X	X	X	X	X
ME FO consumption	kg/h	00000		X	X	X	X	X	X	X	X
FO lower calorific value (LCV)	MJ/kg	00,00		X	X	X	X	X	X	X	X
Relative wind speed	knots	000,0		X	X	X	X	X	X	X	X
Relative wind direction	°	000		X	X	X	X	X	X	X	X
Speed over ground	knots	00,0		X	X	X	X	X	X	X	X
Ship heading	°	000		X	X	X	X	X	X	X	X
Draught forward	m	00,0		X	X	X	X	X	X	X	X
Draught aft	m	00,0		X	X	X	X	X	X	X	X
Water depth	m	000,0	Deep sea, "infinite" depth to be recorded as 1 000 m	X	X	X	X	X	X	X	X
Rudder angle	°	00,0		X	X	X	X	X	X	X	X

Table H.1 (continued)

Parameter	Units	Format	Comments	Application							
				ANNEX_B_SHAFT_POWER				ANNEX_C_BRAKE_POWER			
				1_RE- TRIEVED_ DATASET	2_VALIDATED_ DATASET	3_COR- RECTED_ DATASET	4_PRE- PARED_ DATASET	1_RE- TRIEVED_ DATASET	2_VAL- IDAT- ED_DA- TASET	3_COR- RECTED_ DATASET	4_PRE- PARED_ DATASET
Valid/invalid point		I or V	Describes whether a point is considered VALID (V) or INVALID (I)	X				X			
Performance value (PV)	%	000,0						X			X
Power performance value (ppv)	%	000,0	Applies only when performance value is calculated per Annex K					0			0

Example of 2_VALIDATED_DATASET utilizing ANNEX_B_SHAFT_POWER:

```
2_VALIDATED_DATASET¶
ANNEX_B_SHAFT_POWER¶
Unique identifier (YYYY-MM-DDTHH:MM:SS+/-hh),Speed over water (knots),ME power (kW),ME shaft torque (kN-
m),ME shaft speed (rev/min),Relative wind speed (knots),Relative wind direction (deg),Speed over ground
(knots), ,Ship heading (deg),Draught forward (m),Draught aft (m),Water depth (m),Rudder angle (deg),¶
2014-08-22T16:32:22+00,6.96,9828.72,1183.34,78.82,3.57,65.59,6.85,115.62,7.17,8.26,1000,-0.73¶
2014-08-22T16:32:37+00,7.3,9893.47,1182.17,79.96,3.63,54.62,6.4,115.52,7.05,8.24,1000,1.24¶
2014-08-22T16:32:52+00,7.24,9819.17,1171.02,81.32,4.52,55.88,6.32,115.35,7.15,8.29,1000,-0.31¶
2014-08-22T16:33:07+00,6.95,9953.58,1179.99,81.42,2.26,47.4,7.06,116.83,7.16,8.28,1000,1.92¶
2014-08-22T16:33:22+00,7.22,9823.46,1183.45,79.54,3.31,63.65,6.53,115.14,7.06,8.32,1000,1.24¶
2014-08-22T16:33:37+00,7.27,9821.18,1183.36,80.87,3.55,55.78,6.51,116.54,7.15,8.36,1000,0.72¶
2014-08-22T16:33:52+00,6.83,9811.75,1177.49,79.01,4.85,51.26,6.55,115.69,7.19,8.27,1000,1.33¶
2014-08-22T16:34:07+00,7.18,9913.61,1173.75,79.93,2.95,68.88,6.59,116.04,7.12,8.24,1000,1.78¶
```

Example of 3_CORRECTED_DATASET utilizing ANNEX_C_BRAKE_POWER:

```
3_CORRECTED_DATASET¶
ANNEX_C_BRAKE_POWER¶
Unique identifier (YYYY-MM-DDTHH:MM:SS+/-hh),Speed over water (knots),ME power (kW),ME FO consumption
(kg/hr),FO lower calorific value (LCV) (MJ/kg),Relative wind speed (knots),Relative wind direction
(deg),Speed over ground (knots),Ship heading (deg),Draught forward (m),Draught aft (m),Water depth
(m),Rudder angle (deg)¶
2014-08-22T16:32:22+01,7.34,9897.89,2027.09,42.7,4.94,74.67,6.45,115.32,7.13,8.32,100,1.44¶
2014-08-22T16:32:37+01,6.88,9822.6,2061.4,42.7,2.33,69.91,6.61,115.85,7.14,8.23,100,-0.94¶
2014-08-22T16:32:52+01,7.07,9833.33,2069.99,42.7,3.75,58.2,6.67,115.52,7.04,8.28,100,1.84¶
2014-08-22T16:33:07+01,7.38,9954.3,2036.26,42.7,2,61.28,6.84,116.34,7,8.22,100,1.7¶
2014-08-22T16:33:22+01,6.98,9895.72,2035.92,42.7,5,50.77,6.81,115.66,7.02,8.2,100,-0.62¶
2014-08-22T16:33:37+01,7.17,9883.4,2082.61,42.7,2.49,55.08,6.74,116.88,7.11,8.33,100,-0.96¶
2014-08-22T16:33:52+01,7.03,9961.27,2042.21,42.7,2.08,52.41,6.85,12.72045,,7.17,8.38,100,-0.32¶
2014-08-22T16:34:07+01,7.06,9906.48,2060.81,42.7,3.45,76.3,6.39,115.45,7.16,8.38,100,0.65¶
```

Example of 1_RETRIEVED_DATASET utilizing ANNEX_C_BRAKE_POWER:

```
1_RETRIEVED_DATASET¶
ANNEX_C_BRAKE_POWER¶
Unique identifier (YYYY-MM-DDTHH:MM:SS+/-hh),Speed over water (knots),ME power (kW),ME FO consumption
(kg/hr),FO lower calorific value (LCV) (MJ/kg),Relative wind speed (knots),Relative wind direction
(deg),Speed over ground (knots), Ship heading (deg),Draught forward (m),Draught aft (m),Water depth
(m),Rudder angle (deg),Valid / Invalid point (V/I)¶
2014-08-22T16:32:22-01,7.52,9944.95,2040.77,42.7,3.72,78.96,6.67,12.72124,7.13,8.24,100,1.76,V¶
2014-08-22T16:32:37-01,6.85,9906.2,2029.23,42.7,4.32, ,6.49,12.71803,7.07,8.37,100,0.61,I¶
2014-08-22T16:32:52-01,7.37,9852.18,2040.46,42.7,4.96,55.23,6.93,115.21,7.06,8.35,100,1.45,V¶
2014-08-22T16:33:07-01,7.28,9870.49,2064.76,42.7,3.84,74.51,6.81,116.97,7.14,8.2,100,0.94,V¶
2014-08-22T16:33:22-01,7.51,9893.89,2077.52,42.7,4.13,48.6,6.51,7.12,8.37,100,-0.44,I¶
2014-08-22T16:33:37-01,7.5,9970.47,2079.78,42.7,3.78,70.65,6.93,116.05,7.14,8.37,100,0.76,V¶
2014-08-22T16:33:52-01,6.82,9852.3,2065.54,42.7,3.06,64.83,6.54,115.14,7.06,8.36,100,1.51,V¶
2014-08-22T16:34:07-01,7,9803.38,2028.91,42.7,4.85,79.07,7.1,116.23,7.03,8.23,100,1.44,V¶
```

Example of 4_PREPARED_DATASET utilizing ANNEX_B_SHAFT_POWER:

4_PREPARED_DATASET¶

ANNEX_B_SHAFT_POWER¶

Unique identifier (YYYY-MM-DDTHH:MM:SS+/-hh),Speed over water (knots),ME power (kW),ME shaft torque (kNm),ME shaft speed (rev/min),Relative wind speed (knots),Relative wind direction (deg),Speed over ground (knots),Ship heading (deg),Draught forward (m),Draught aft (m),Water depth (m),Rudder angle (deg),Performance Value (PV) (%)¶

2014-08-22T16:32:22+00,7.34,9841.96,1187.27,79.02,2.78,63.91,6.83,116.57,7.2,8.24,100,-0.95,96.47912¶

2014-08-22T16:32:37+00,7.29,9876.93,1171.89,81.16,3.42,72.06,7.02,116.5,7.18,8.28,100,-0.66,96.43267¶

2014-08-22T16:32:52+00,7.07,9988.99,1172.42,81.7,4.74,58.92,6.43,115.46,7.16,8.38,100,0.25,94.87492¶

2014-08-22T16:33:07+00,7.31,9918.25,1181.45,79.77,3.78,56.13,6.67,116.98,7.12,8.25,100,0.18,94.60446¶

2014-08-22T16:33:22+00,7.49,9829.3,1190.91,80.52,2.06,49.57,6.48,115.36,7.2,8.38,100,1.7,94.53748¶

2014-08-22T16:33:37+00,7.09,9890.59,1186.4,81.11,4.35,59.23,6.91,116.88,7.02,8.39,100,1.83,94.78629¶

2014-08-22T16:33:52+00,7.04,9928.2,1194.11,78.25,3.04,79.81,6.44,116.99,7.08,8.38,100,-0.64,95.99877¶

2014-08-22T16:34:07+00,7.09,9902.07,1179.32,78.25,2.84,78.88,6.92,116.86,7.13,8.38,100,0.86,94.39337

Annex I (normative)

Outlier detection

Outliers are detected as follows (Chauvenet's criterion).

For the purpose mean and standard error of the mean for the N data in a data block with values, d_i have to be computed.

Computation of mean

For data that are not measured as angles, the mean μ for the N data in a data block with values d_i are computed according to [Formula \(I.1\)](#):

$$\mu = \frac{1}{N} \sum_{i=1}^N d_i \quad (I.1)$$

For data that are measured as angles, the mean μ for the N data in a data block with values d_i is computed as according to [Formula \(I.2\)](#):

$$\mu = \text{atan2} \left(\frac{\sum_{i=1}^N \sin(d_i)}{N}, \frac{\sum_{i=1}^N \cos(d_i)}{N} \right) \quad (I.2)$$

where

atan2 is the arctangent function with two arguments.

Computation of standard error of the mean

For the computation of the standard error of the mean for the N data in a data block with values d_i , the difference Δ_i between the values d_i and the mean μ are to be computed.

For data not measured as angles, the difference is computed following [Formula \(I.3\)](#):

$$\Delta_i = |(d_i - \mu)| \quad (I.3)$$

For data measured as angles, the difference is computed following [Formula \(I.4\)](#):

$$\left[\begin{array}{l} \text{If } r_i = \text{mod}(|(d_i - \mu)|, 360) > 180^\circ \Delta_i = 360^\circ - r_i \\ \text{otherwise} \quad \Delta_i = r_i \end{array} \right] \quad (I.4)$$

where

mod(k,l) is the modulo of two entries k and l

The standard error of the mean is computed following [Formula \(I.5\)](#):

$$\sigma = \sqrt{\frac{1}{N} \sum_{i=1}^N \Delta_i^2} \quad (I.5)$$

Chauvenet's criterion

The probability for the occurrence of any value d_i is computed according to [Formula \(I.6\)](#):

$$P(d_i) = \operatorname{erfc}\left(\frac{\Delta_i}{\sigma \cdot \sqrt{2}}\right) \quad (\text{I.6})$$

where

$P(d_i)$ is the probability of occurrence of d_i ;

erfc is the complementary error function.

A datum is considered an outlier if [Formula \(I.7\)](#) is fulfilled:

$$P(d_i) \cdot N < 0,5 \quad (\text{I.7})$$

Annex J (normative)

Validation

- a) For every 10 min block j with N data values d_i , the mean, μ , and the standard error of the mean, σ , are computed following [Formulae \(I.1\)](#) to [\(I.5\)](#) for the data of the parameters rpm, speed through water and speed over ground and rudder angle.

If the standard error of the mean of any of the parameters is larger than the below specified thresholds, the 10 min block j is invalid for all parameters.

Threshold values for the standard error of the mean:

- rpm: 3 min⁻¹;
 - speed through water: 0,5 knots;
 - speed over ground: 0,5 knots;
 - rudder angle: 1°.
- b) In case of twin screw vessels, the difference between the mean delivered power value for the starboard and port shaft in a 10 min data block shall be less than 5 %. The differences in the mean starboard and port rpm in a 10 min data block shall be less than 1 %. Otherwise, the data block is invalid.

The data set should be analysed for sensor drifting. Methods for analysing sensor drifting are currently not mature and/or generally available and future revisions of this document may evaluate possible standard methods for sensor drift analysis.

Annex K (informative)

Method for calculating power performance values (PPV) and power performance indicators (PPI)

This annex provides a method for calculating power performance values (PPV) and power performance indicators (PPI) as alternatives to the defined performance values and performance indicators, respectively.

The method prescribed in ISO 19030 (all parts) remains relevant except those parts identified below, which are replaced in their entirety with the following:

- all references to “PV” are changed to “PPV” and “PI” to “PPI”;
- [5.4.7.2](#) Percentage power increase:

The percentage power increase, P_d , is calculated as the relative difference in percent between the measured corrected delivered power, P_m , and the expected delivered power, P_e ; see [Formula \(K.1\)](#).

$$P_d = 100 \cdot \frac{P_m - P_e}{P_e} \quad (\text{K.1})$$

- [5.4.7.3](#) Expected delivered power:

The expected delivered power is read from a speed-power reference curve at the measured speed through water and at the measured displacement and trim. The origin of the speed-power reference curves is defined in [4.5](#) and the same set of speed-power reference curves have to be used in the reference and the evaluation periods. The displacement for a given draught and trim is to be read from the displacement tables of the vessel in question. The displacement shall be computed from static draught and trim.

- [6.3.5.1](#) Average percentage power increase over the reference period(s):

The average percentage increase over the reference period(s) shall be calculated using [Formula \(K.2\)](#):

$$\bar{P}_{d,\text{ref}} = \frac{1}{k} \sum_j \frac{1}{n} \sum_i P_{d,j,i} \quad (\text{K.2})$$

where

- k is the number of reference periods;
- j is the reference period counter;
- n is the number of data points in the processed data set under reference conditions in the reference period j ;
- i is the counter of data points in reference period j ;
- $P_{d,j,i}$ is the percentage power increase for data point i in reference period j ;
- $\bar{P}_{d,\text{ref}}$ is the average percentage power increase over the reference period(s).

- [6.3.5.2](#) Calculation of average percentage power increase over the evaluation period:

For the evaluation period data set, the average percentage power increase over the evaluation period, $P_{d,eval}$, shall be calculated using [Formula \(K.3\)](#):

$$\bar{P}_{d,eval} = \frac{1}{n} \sum_i^n P_{d,eval,i} \quad (K.3)$$

where

n is the number of data points in the processed data set under reference conditions of the evaluation period;

$P_{d,eval,i}$ is the percentage power increase for data point i in a data set of the evaluation period;

$\bar{P}_{d,eval}$ is the average percentage power increase in data set of the evaluation period.

- [6.3.5.3](#) Calculation of the differences between the average percentage power increase of the reference period and the evaluation period:

The change in the average power increase in the reference period(s) and the average power increase in the evaluation period is defined as power performance indicator, PPI, and is calculated according to [Formula \(K.4\)](#):

$$k_{HP-P} = \bar{P}_{d,eval} - \bar{P}_{d,ref} \quad (K.4)$$

Bibliography

- [1] ISO 8601, *Data elements and interchange formats — Information interchange — Representation of dates and times*
- [2] ISO 19030-3:2016, *Ships and marine technology — Measurement of changes in hull and propeller performance — Part 3: Alternative methods*
- [3] MEPC. *Air pollution and energy efficiency, Additional information on revision of ISO 15016:2002, submitted by ISO and ITTC, MEPC 66/Inf.7*. IMO, London, 2013

British Standards Institution (BSI)

BSI is the national body responsible for preparing British Standards and other standards-related publications, information and services.

BSI is incorporated by Royal Charter. British Standards and other standardization products are published by BSI Standards Limited.

About us

We bring together business, industry, government, consumers, innovators and others to shape their combined experience and expertise into standards-based solutions.

The knowledge embodied in our standards has been carefully assembled in a dependable format and refined through our open consultation process. Organizations of all sizes and across all sectors choose standards to help them achieve their goals.

Information on standards

We can provide you with the knowledge that your organization needs to succeed. Find out more about British Standards by visiting our website at bsigroup.com/standards or contacting our Customer Services team or Knowledge Centre.

Buying standards

You can buy and download PDF versions of BSI publications, including British and adopted European and international standards, through our website at bsigroup.com/shop, where hard copies can also be purchased.

If you need international and foreign standards from other Standards Development Organizations, hard copies can be ordered from our Customer Services team.

Copyright in BSI publications

All the content in BSI publications, including British Standards, is the property of and copyrighted by BSI or some person or entity that owns copyright in the information used (such as the international standardization bodies) and has formally licensed such information to BSI for commercial publication and use.

Save for the provisions below, you may not transfer, share or disseminate any portion of the standard to any other person. You may not adapt, distribute, commercially exploit, or publicly display the standard or any portion thereof in any manner whatsoever without BSI's prior written consent.

Storing and using standards

Standards purchased in soft copy format:

- A British Standard purchased in soft copy format is licensed to a sole named user for personal or internal company use only.
- The standard may be stored on more than 1 device provided that it is accessible by the sole named user only and that only 1 copy is accessed at any one time.
- A single paper copy may be printed for personal or internal company use only.

Standards purchased in hard copy format:

- A British Standard purchased in hard copy format is for personal or internal company use only.
- It may not be further reproduced – in any format – to create an additional copy. This includes scanning of the document.

If you need more than 1 copy of the document, or if you wish to share the document on an internal network, you can save money by choosing a subscription product (see 'Subscriptions').

Reproducing extracts

For permission to reproduce content from BSI publications contact the BSI Copyright & Licensing team.

Subscriptions

Our range of subscription services are designed to make using standards easier for you. For further information on our subscription products go to bsigroup.com/subscriptions.

With **British Standards Online (BSOL)** you'll have instant access to over 55,000 British and adopted European and international standards from your desktop. It's available 24/7 and is refreshed daily so you'll always be up to date.

You can keep in touch with standards developments and receive substantial discounts on the purchase price of standards, both in single copy and subscription format, by becoming a **BSI Subscribing Member**.

PLUS is an updating service exclusive to BSI Subscribing Members. You will automatically receive the latest hard copy of your standards when they're revised or replaced.

To find out more about becoming a BSI Subscribing Member and the benefits of membership, please visit bsigroup.com/shop.

With a **Multi-User Network Licence (MUNL)** you are able to host standards publications on your intranet. Licences can cover as few or as many users as you wish. With updates supplied as soon as they're available, you can be sure your documentation is current. For further information, email subscriptions@bsigroup.com.

Revisions

Our British Standards and other publications are updated by amendment or revision.

We continually improve the quality of our products and services to benefit your business. If you find an inaccuracy or ambiguity within a British Standard or other BSI publication please inform the Knowledge Centre.

Useful Contacts

Customer Services

Tel: +44 345 086 9001

Email (orders): orders@bsigroup.com

Email (enquiries): cservices@bsigroup.com

Subscriptions

Tel: +44 345 086 9001

Email: subscriptions@bsigroup.com

Knowledge Centre

Tel: +44 20 8996 7004

Email: knowledgecentre@bsigroup.com

Copyright & Licensing

Tel: +44 20 8996 7070

Email: copyright@bsigroup.com

BSI Group Headquarters

389 Chiswick High Road London W4 4AL UK