

BS ISO 18933:2012



BSI Standards Publication

Imaging materials — Magnetic tape — Care and handling practices for extended usage

bsi.

...making excellence a habit.™

National foreword

This British Standard is the UK implementation of ISO 18933:2012. It supersedes BS ISO 18933:2006 which is withdrawn.

The UK participation in its preparation was entrusted to Technical Committee CPW/42, Photography.

A list of organizations represented on this committee can be obtained on request to its secretary.

This publication does not purport to include all the necessary provisions of a contract. Users are responsible for its correct application.

© The British Standards Institution 2012. Published by BSI Standards Limited 2012

ISBN 978 0 580 77258 0

ICS 35.220.22; 37.040.99

Compliance with a British Standard cannot confer immunity from legal obligations.

This British Standard was published under the authority of the Standards Policy and Strategy Committee on 31 May 2012.

Amendments issued since publication

Date	Text affected
------	---------------

INTERNATIONAL STANDARD

BS ISO 18933:2012

ISO
18933

Second edition
2012-05-15

Imaging materials — Magnetic tape — Care and handling practices for extended usage

*Matériaux pour l'image — Bande magnétique — Précautions et
pratiques de manutention pour usage prolongé*



Reference number
ISO 18933:2012(E)

© ISO 2012



COPYRIGHT PROTECTED DOCUMENT

© ISO 2012

All rights reserved. Unless otherwise specified, no part of this publication may be reproduced or utilized in any form or by any means, electronic or mechanical, including photocopying and microfilm, without permission in writing from either ISO at the address below or ISO's member body in the country of the requester.

ISO copyright office
Case postale 56 • CH-1211 Geneva 20
Tel. + 41 22 749 01 11
Fax + 41 22 749 09 47
E-mail copyright@iso.org
Web www.iso.org

Published in Switzerland

Contents

Page

Foreword	v
Introduction	vi
1 Scope	1
2 Normative references	1
3 Terms and definitions	1
4 Tape pack integrity	5
4.1 General	5
4.2 Common pack problems	5
4.3 Pack tension	6
4.4 Tape winding speed	7
4.5 Tape, hub and reel design	8
5 Contamination	8
5.1 General	8
5.2 Particulate contaminants	10
5.3 Gaseous contaminants	10
5.4 Organic contaminants	10
5.5 Protective cases	10
5.6 Field usage	10
6 Handling techniques	11
6.1 General	11
6.2 Vertical/horizontal tape orientation	11
6.3 Handling access	11
6.4 Use of force	12
6.5 Tape condition	12
6.6 General handling	13
7 Environment	13
7.1 General	13
7.2 Temperature and humidity	13
7.3 Air quality	14
7.4 Magnetic fields	14
7.5 Light exposure	15
7.6 Acclimatization	15
7.7 Marginal environments	15
8 Inspection	16
8.1 General	16
8.2 Seven-step physical inspection	16
9 Cleaning and maintenance	17
9.1 General	17
9.2 Tape cleaning indicators	18
9.3 Tape cleaning frequency	18
9.4 Debris removal from tape	18
9.5 Adhesive contaminants on tape	18
9.6 Biological contaminants on tape	19
9.7 Record/playback machine maintenance	19
9.8 Transports for master tapes	19
9.9 Manufacturers' recommendations	19
9.10 Cleaning cassettes	19
9.11 Hand cleaning	19
10 Transportation	19
10.1 General	19
10.2 Tape preparation before transport	19

10.3	Transport methods	20
10.4	General exposure	21
10.5	External fields and security scanning of material	21
11	Disasters	21
11.1	General	21
11.2	Water	22
11.3	Fire	22
11.4	Dry debris	22
11.5	Disaster response	22
12	Staff training	23
12.1	Purpose	23
12.2	Training paths	23
12.3	Schedule for training	24
12.4	Update of training	24
12.5	Content of training	24
13	Minimum handling requirements checklist	24
13.1	General	24
13.2	Do's	24
13.3	Do not's	25
	Bibliography	26

Foreword

ISO (the International Organization for Standardization) is a worldwide federation of national standards bodies (ISO member bodies). The work of preparing International Standards is normally carried out through ISO technical committees. Each member body interested in a subject for which a technical committee has been established has the right to be represented on that committee. International organizations, governmental and non-governmental, in liaison with ISO, also take part in the work. ISO collaborates closely with the International Electrotechnical Commission (IEC) on all matters of electrotechnical standardization.

International Standards are drafted in accordance with the rules given in the ISO/IEC Directives, Part 2.

The main task of technical committees is to prepare International Standards. Draft International Standards adopted by the technical committees are circulated to the member bodies for voting. Publication as an International Standard requires approval by at least 75 % of the member bodies casting a vote.

Attention is drawn to the possibility that some of the elements of this document may be the subject of patent rights. ISO shall not be held responsible for identifying any or all such patent rights.

ISO 18933 was prepared by Technical Committee ISO/TC 42, *Photography*.

This second edition cancels and replaces the first edition (ISO 18933:2006), of which it constitutes a minor revision with the following changes:

- 1) Annex A has been removed, to be consistent with same change made in other ISO/TC 42 standards.
- 2) In Clause 2, the titles of ISO 14644-1 and ISO 14644-2 have been updated to reflect the latest versions.
- 3) In the definition for *backcoat* (3.2), “increase friction” has been changed to “modify friction”.
- 4) The terminological entry for *class 100 000 cleanroom* (formerly 3.10) has been removed and the remaining terms re-numbered. The reference to a “class 100 000” cleanroom has been added to 7.3.3 *Cleanroom specifications*.
- 5) In the definition for *master* (now 3.26; formerly 3.27), “e.g. camera master, edited master, foreign language master” has been moved into an example.
- 6) In the definition for *tape pack* (now 3.43; formerly 3.44), “length of magnetic tape” has been changed to “magnetic tape wound on a reel or hub”.
- 7) The terminological entry for *wind* (formerly 3.45) included two separate definitions; it has been split into two entries (3.44 and 3.45), differentiated by the use of parts of speech.
- 8) The terminological entry for *windows* (formerly 3.46) included three definitions; the first has been retained and the singular tense has been used.
- 9) In 4.5.2 *Backcoat surface of the tape*, “increases friction” has been changed to “modifies friction”.

Introduction

This International Standard is one of a series of International Standards dealing with the physical properties and stability of imaging materials.

Magnetic recording tape has served as a major means of processing, distributing and preserving information, including video, audio, computer and other data since the 1930s. Unlike earlier data-recording media such as paper and photographic material, the information recorded on magnetic tape is not directly human-readable and requires a machine interface and interpretation. In addition, the machine/medium interface must occur within precise conditions in order for the machine interpretation to be accurate. Therefore, the physical integrity of magnetic tape necessary to provide a proper interface with the interpreting machinery is critical. Correct care and handling is essential to preserve the needed physical integrity of magnetic tape both for short-term usage and long-term archiving.

Magnetic tape has proven itself an easy-to-use and versatile medium. Yet despite the substantial resources put into creating recordings and the historical, intellectual and financial assets they represent, tapes often are not treated as valuable objects. Many important and unique recordings are lost due to inadequate care and handling of the tape. This poses problems for users who wish to preserve the content. Among these problems are the following.

Improper handling can damage magnetic tapes and compromise the future ability to retrieve content.

Due to the enormous volume of existing tapes, the impracticality and cost of making copies of each and every one frequently results in large numbers of unique records being subjected to excessive use and wear without any back-up or protection. Repeated use of magnetic tape can cause wear or physical damage that shortens its effective life.

Some magnetic tapes are known to have a finite shelf life and will eventually decay. Recorded documents on these tapes must be copied to new media before decay precludes access.

The ability to play back a tape in the future depends on the existence of functional playback equipment. As new tape formats become popular, equipment manufacturers discontinue the production and support of older, superseded equipment. Eventually, usable equipment to play older, obsolete magnetic tape formats becomes impossible to find. Before this occurs, a migration plan should be in place.

Like all media, magnetic tape is subject to both damage and decay. Consequently, its effective life can increase or decrease significantly depending on the conditions under which it is stored and handled. This International Standard contains recommendations for the care and handling of magnetic tape. Recommendations for the preservation and storage of polyester-base magnetic tape appear in ISO 18923. Following these recommendations promotes the physical integrity of the media and increases the effective life of magnetic tape.

Imaging materials — Magnetic tape — Care and handling practices for extended usage

1 Scope

This International Standard concerns the care and handling of magnetic recording tape during use. It addresses the issues of physical integrity of the medium necessary to preserve access to the data (information) recorded on the tape. This International Standard recommends handling procedures to maximize the effective life of magnetic tape. Faulty handling, packing and transporting techniques and methods often cause damage to magnetic tape and the content recorded thereon. Extending the longevity of magnetic tape requires the identification of appropriate handling methods and well-developed training programmes.

While some of the recommendations in this International Standard, such as staff training, apply specifically to large-scale or archival usage, the basics of all recommendations in this document can and should be applied in all circumstances where the desired result is long-term usage of the medium whether archival, commercial or personal.

This International Standard addresses the following subjects:

- handling techniques, including common hazards and methods to mitigate those hazards;
- handling environments, including pollutants, temperature and humidity, lighting, magnetic fields and robotics;
- use of tape, including inspection, playback, mounting/loading and removing, winding speed, tension and robotic systems;
- cleaning and maintenance techniques, including contaminants, cleaning methods and frequency;
- transportation, both in-house and shipping outside the storage facility;
- disasters, including water, fire, construction and post-disaster procedures;
- staff training, including schedule for training and contents of the training programme;
- archival issues.

2 Normative references

The following referenced documents are indispensable for the application of this document. For dated references, only the edition cited applies. For undated references, the latest edition of the referenced document (including any amendments) applies.

ISO 14644-1, *Cleanrooms and associated controlled environments — Part 1: Classification of air cleanliness by particle concentration*

ISO 14644-2, *Cleanrooms and associated controlled environments — Part 2: Specifications for monitoring and periodic testing to prove continued compliance with ISO 14644-1*

ISO 18923, *Imaging materials — Polyester-base magnetic tape — Storage practices*

3 Terms and definitions

For the purposes of this document, the following terms and definitions apply.

- 3.1**
acclimatization
staging
process of conditioning material from one set of temperature/moisture conditions to another
- 3.2**
backcoat
<magnetic tape> rough surface layer added to the back of the basefilm to modify friction and minimize slippage between tape strands
- 3.3**
basefilm
base
plastic (polymer) substrate to which the magnetic layers are attached
- 3.4**
binder
<magnetic tape> plastic (polymer) in which the magnetic particles are bound in order to create the recording layers of the tape and which binds the recording layers to the basefilm
- 3.5**
carrier
medium upon which the information is recorded
- 3.6**
carton box
outer container that can hold one or more individual units and may be a fabrication of paper, card stock or plastic
- 3.7**
cartridge
housing for a roll of recording material, such as photographic film or magnetic tape, wound on a single hub or reel
See **cassette** (3.8).
- 3.8**
cassette
housing for a roll of recording material, such as photographic film or magnetic tape, whose ends are attached to two hubs or reels
- 3.9**
cinching
tape folding back upon itself within the tape pack
- 3.10**
conditioning
exposure of a specimen to air at a given relative humidity and temperature until equilibrium is reached
- 3.11**
container
box, can or carton used for storage and shipping of recording materials
NOTE Reels, cassettes, cartridges, or shells are not containers; the box into which a reel, cassette, cartridge or shell is placed is defined as a container.
- 3.12**
copy
reproduction of the information from a master
- 3.13**
domain
magnetic domain
cluster of the embedded magnetic particles which all align in the same north-south direction

3.14

extended-term storage conditions

storage conditions suitable for the preservation of recorded information having permanent value

3.15

flange

fixed or removable circular disc that is connected to the hub to make a reel for the purpose of protecting the roll of recording materials

See **reel** (3.33).

3.16

flange pack

condition where the whole tape pack rests against one flange

3.17

format

dimensions of the magnetic recording and its assembly as well as the physical and magnetic specifications of the recording on the tape

3.18

heads out

configuration of magnetic tape stored on its reel or in its cassette such that the tape is positioned to play from the beginning of the recorded information

3.19

hub

cylindrical object around which the recording material is wound

3.20

hydrolysis

decomposition involving a reaction with water that results in the splitting of chemical bonds

3.21

leader

flexible plastic or paper strip which can be spliced to either end of a roll of recording material

NOTE This practice is not recommended for extended-term storage.

3.22

leafing

multiple popped strands in a magnetic-tape wind

See **popped strand** (3.31) and **stepped pack** (3.40).

3.23

library wind

low-speed rewind at controlled tension to achieve a smooth tape pack

NOTE The low speed rewind is typically 1 m/s to 3 m/s.

3.24

loose pack

undesirable pack condition in a roll of recording material, such that the outer portion of the roll can be moved and tightened by pulling on the end

3.25

magnetic field intensity

magnitude of the magnetic field, in amperes per meter, at a point in space

3.26

master

original or primary recording of the data or any version of the data

EXAMPLE Camera master, edited master, foreign language master.

3.27

medium

media, pl

material on which information is recorded

See **carrier** (3.5).

3.28

medium-term storage conditions

storage conditions suitable for the preservation of recorded information for a minimum of 10 years

3.29

migration

transferring information from one format to another

3.30

oligomer

low molecular-weight polymer which can be produced by degradation of the magnetic tape binder

3.31

popped strand

lateral displacement of a single strand or wrap of magnetic tape extending beyond the plane of the tape pack

See **leafing** (3.22) and **stepped pack** (3.40).

3.32

print-through

unintentional magnetic transfer of the recording on one layer of magnetic tape to the adjacent layers during storage on a reel/hub

3.33

reel

metal or plastic hub or core with flanges (protective sides) onto which recording material is wound

3.34

shell

outer housing of a cassette or cartridge

3.35

slot

space or slit in the winding surface of a reel or hub

3.36

splice

union of two pieces of recording or leader material to form a single piece

3.37

splicing tape

paper or plastic strip coated with a thermal or pressure-sensitive adhesive, used in splicing

3.38

spoking

deformations in a roll pack that appear radially outward and disrupt the circular nature of the wind

3.39

staging acclimatization

process of conditioning material from one set of temperature/moisture conditions to another

3.40

stepped pack

multiple adjacent strands of magnetic tape extending beyond the level of a tape pack

See **leafing** (3.22) and **popped strand** (3.31).

3.41

storage environment

conditions for storing materials, i.e. temperature, relative humidity, cleanliness of facilities and atmospheric pollutants

3.42

tails out

configuration of magnetic tape stored on its reel, or in its cassette, such that the tape must be fully rewound in order to correctly play from the beginning of the recorded information

3.43

tape pack

magnetic tape wound on a reel or hub

3.44

wind, noun

physical appearance and tension of the magnetic tape pack

3.45

wind, verb

process of transferring a roll of recording material from one spool or reel to another

3.46

window

windage hole

opening in the flanges of a tape reel

4 Tape pack integrity

4.1 General

The physical integrity of the tape pack shall be maintained to avoid damage to the tape and allow for proper retrieval of the recorded content. Tape pack integrity is dependent on several variables and loss of pack integrity can have a variety of negative effects.

4.2 Common pack problems

4.2.1 Pack deformation

Edge damage and tape deformation will alter the quality of the tape pack, resulting in spoking or a lipped-edged pack (see Figure 1).

4.2.2 Flange pack

If the tape pack is against one flange, then there is a misalignment between the tape reel and the tape edge guide nearest the tape reel.

4.2.3 Pack slippage

Vibration or impact will often result in slippage of the pack causing edge damage if the winding tension is too low. The pack is most susceptible to slippage while a tape is held horizontally.

4.2.4 Pack penetration or abrasion

Any portion of the tape pack that is exposed is especially vulnerable to damage. Fingers shall not be inserted through the window of a flange except in an empty reel when threading an open reel tape.

4.2.5 Edge compression

Mounting and unmounting large reels of tape requires special care. Tape reels shall be handled by the hub and the flanges shall not be squeezed. Compressing the flanges can crack the magnetic coating on tape edges and deform the basefilm resulting in poor head-to-tape contact. Tape with laterally misaligned strands is extremely susceptible to edge compression damage [see popped strand (3.31)].

4.3 Pack tension

4.3.1 General

If a tape is not wound at the proper tension, the tape pack is likely to become distorted during storage. When a distorted pack is unwound, tape surface deformation will be noticed at spacings equal to the circumference of the tape pack at that point. Tape surface deformation is likely to cause poor head-to-tape contact.

NOTE Most tape deformation can be returned to normal by a knowledgeable tape restoration professional - except where a tape layer has been folded.

4.3.2 Tension control

The tape tension is controlled by the design and maintenance of the tape machine. Tape tension can be measured by a technician with a special tape tension gauge.

4.3.3 Winding tension

Tape shall be wound on a hub, not touching a flange, within a range of tensions that allows the tape to maintain a uniform pack without imposing unnecessary longitudinal stress.

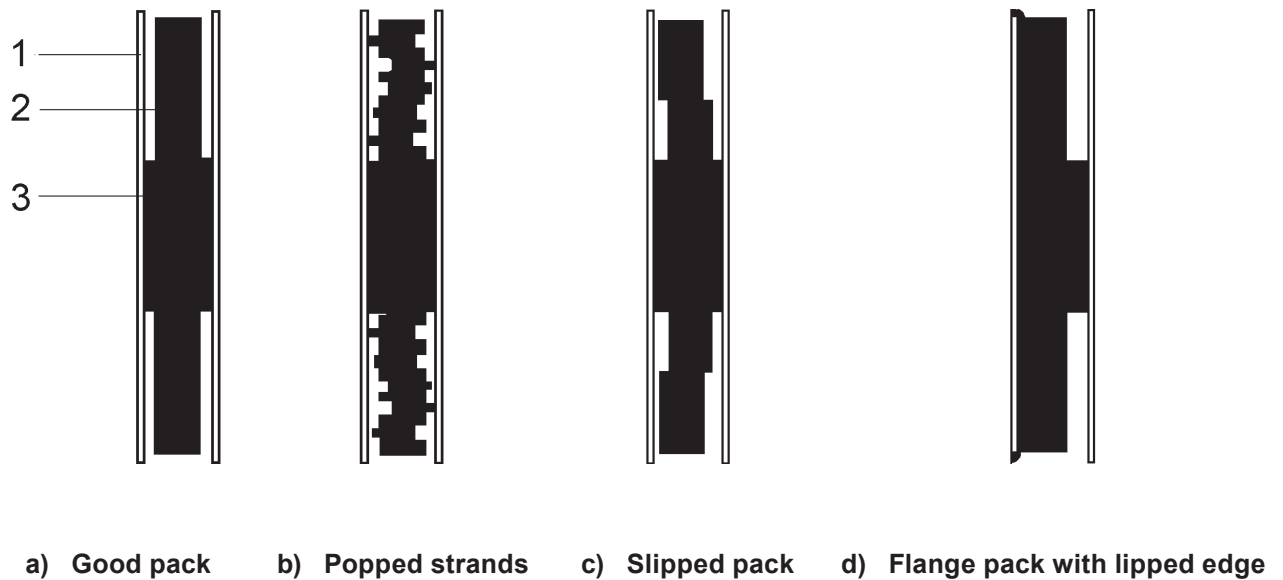

Key

- 1 reel flange
- 2 tape pack
- 3 hub

Figure 1 — Examples of tape packs

4.4 Tape winding speed

4.4.1 General

The speed of the tape while it is being packed onto the reel can affect the tape pack. When tape is wound at high speed, air is trapped between the tape strands and can cause pack irregularities. At play or record speeds, air is not trapped between layers and the tape will develop a smooth-edged pack, unless the tape edges have been damaged.

4.4.2 Library wind

Library wind mode shall be used, when available, before storage. This mode is a special option on some tape machines that wind the tape at low speed.

4.4.3 Winding loose packs

If a tape pack is loose, it shall not be run at fast forward or fast rewind speeds. The tape shall be run in play mode to the end and then rewound. Very loose tape packs shall be hand wound or wound on a machine with reduced tension to avoid cinching and other damage. For cassette tapes, this may require special handling or machinery and expert assistance to avoid tape damage.

4.5 Tape, hub and reel design

4.5.1 General

Design elements of the tape, hub and reel can affect the tape pack.

4.5.2 Backcoat surface of the tape

Backcoated tape has a rough surface that modifies friction, thus minimizing slippage between tape strands and loss of tape pack integrity.

4.5.3 Splices

Tapes shall not be spliced except as required for repair prior to playback or when the splice is part of the manufacturing process (i.e. attaching tape ends to leader). The problems created by splices include deformation, delamination, adhesive bleed, alignment problems and tape head damage.

4.5.4 Hub diameter

Pack slippage is less likely to occur on reels where the ratio of the outer pack to hub diameter is less than 2,5.

4.5.5 Flangeless hubs

Sometimes magnetic tape is stored on flangeless hubs. When this practice is used, the following recommendations shall be observed.

- a) Only backcoated tape designed for storage on a flangeless hub shall be stored in this manner. Non-backcoated tape will not wind properly and is at high risk of falling off the tape pack.
- b) Tape tension is especially critical; too loose a wind will result in immediate disintegration of the tape pack.
- c) The loose end of the tape shall be fixed down with non-residue-producing adhesive tape. Tapes shall be held only between the hub and the outside wind, without touching the surface of the tape pack.
- d) Extreme caution shall be used when handling tapes without flanges. Loose tapes shall be rewound on a correctly adjusted tape machine.

4.5.6 Reel flanges with openings (windows)

When tape is wound at high speed (fast forward or rewind), air is trapped between the tape strands but can escape if the flange is designed with openings. This ensures good contact between the surfaces of adjacent strands.

4.5.7 Cassettes and cartridges

Tape cassettes and cartridges shall be wound entirely to one end at play speed or to a special parking area designated by the machine manufacturer to avoid deformation of recorded sections of the tape from prolonged contact with internal guide posts.

5 Contamination

5.1 General

Magnetic tapes are highly susceptible to contamination.

Figure 2 shows the relative size of debris commonly found on magnetic recording tapes and in tape machines, relative to the head-to-tape spacing. It is clear from this diagram that even the smallest airborne particles can result in errors if the debris gets between the head and the tape.

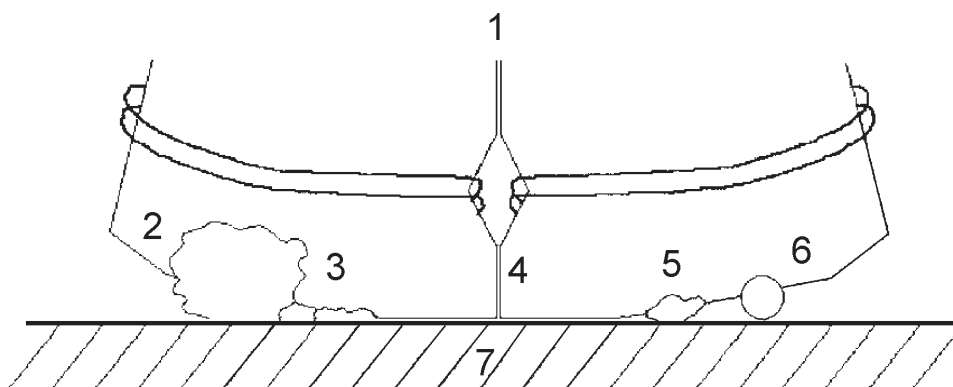

Key

- 1 video head
- 2 cotton fibre
- 3 finger print
- 4 gap
- 5 dust
- 6 human hair
- 7 magnetic tape surface

Figure 2 — Debris on the surface of the tape

Figure 3 is a photograph of a small section of tape that has been covered with very fine iron particles to show 10 recorded video tracks. The “mountain” in the middle of the photograph is a small piece of debris. It is surrounded by empty space caused when the video head skipped over the debris and did not record part of two video tracks.

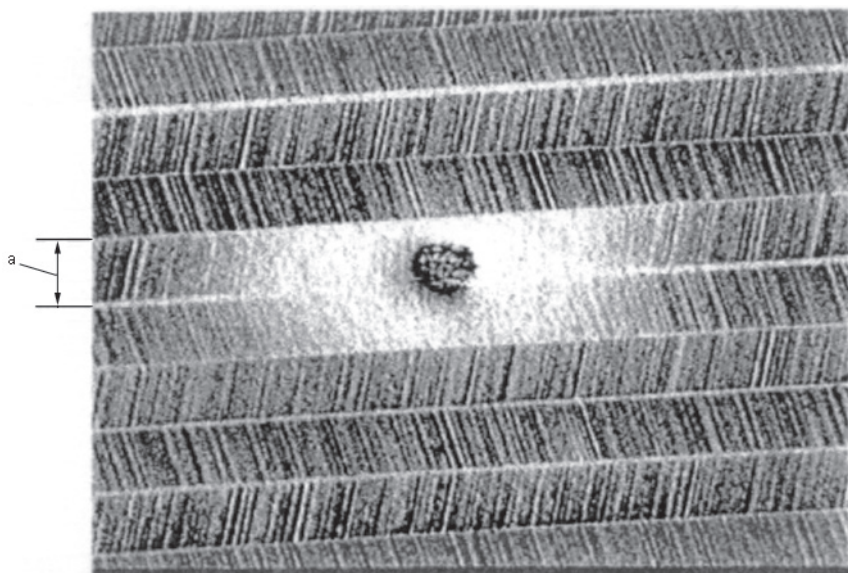

a One track.

Figure 3 — Loss of data due to a clump of debris on the surface of the tape

5.2 Particulate contaminants

Particulate contaminants will block access to material recorded on a tape and can cause physical damage to both tape and machinery. Dust, smoke and debris-generating objects or materials (e.g. carpets, draperies, unsealed insulation, packaging blankets and other padding materials, fibrous wall coverings and furnishings) shall not be present in any area where extended-life tapes are being handled or used. In areas where sound levels shall be minimized, special non-debris generating material shall be used.

5.3 Gaseous contaminants

Gaseous pollutants, such as exhaust fumes and fumes from ammonia- and chloride-based cleansers, cause chemical reactions that are harmful to magnetic recording tapes. Positive air pressure shall be maintained in tape usage areas to reduce ingress of gaseous contaminants (see 7.3.2). Ammonia- and chloride-based cleansers shall not be used in tape handling or usage areas.

5.4 Organic contaminants

5.4.1 General

Organic contaminants damage tape in two ways: by directly damaging the tape and by attracting and holding other contaminants in contact with the tape.

5.4.2 Human-transferred contaminants

Personnel shall wash their hands before handling magnetic tapes or protective cases since human skin is constantly being shed. Epidermal oils and artificial substances such as lotions are easily transferred to magnetic recording tape. Such oils can be destructive to the tape and may carry other damaging contaminants and debris. Consequently, small flakes of skin and oily fingerprints are among the most common contaminants found on tape.

5.4.3 Consumables

Magnetic tape use and handling areas shall be kept free of food, beverages and smoke. Food and drink pose a threat to magnetic recording tape both because they contain destructive agents and because they can attract and hold other pollutants. Many foods, especially those that contain sugars, have adhesive characteristics that will cause tape to stick to itself and other objects. Decaying food also can result in fungal growth or the attraction of destructive vermin.

5.4.4 Biological contaminants

The most common biological contaminant of tape is fungus. Fungus shall be considered toxic and treated with great care. Unprotected personnel shall not handle tapes containing fungus.

5.5 Protective cases

Protective cases shall not be opened, and magnetic recording tapes shall not be removed from their cases, in environments where a large amount of particulate matter is present or is likely to be generated such as in shipping rooms or machine shops.

5.6 Field usage

For field applications, tapes shall be transported in their protective cases and left in the recorder only during use. In the field, tapes and tape cases shall be shielded at all times from exposure to moisture, temperature extremes, dust and sunlight.

6 Handling techniques

6.1 General

Magnetic tape is easily damaged by improper handling. Proper techniques shall be used when handling magnetic tapes to avoid damaging the medium in ways that will shorten the usable life of the tape or interfere with the future ability to retrieve information from the tape.

6.2 Vertical/horizontal tape orientation

6.2.1 Tape position

The position of the tape during handling and the user's grip will affect the tape's susceptibility to damage.

6.2.2 Reel-to-reel tapes

Reels of magnetic recording tape shall be held vertically, by the centre hub or supported by the edges of the flanges, without putting pressure on the flat surfaces of the flanges.

6.2.3 Cassettes and cartridges

Cassettes and cartridges shall be positioned vertically except when it is necessary to change their orientation in order to insert or remove them from equipment. Cassettes and cartridges shall be held touching only the rigid outer casing or shell and not the movable lid or the hub.

6.2.4 Transportation

Magnetic tape recordings shall be transported, in-house as well as between facilities, vertically in their protective cases. Tapes shall be removed from their cases only for inspection or immediate use.

6.2.5 Removal from protective cases

Protective cases shall be placed horizontally on a clean, flat, uncluttered surface when opening the case to remove the magnetic recording tape. Other than during this operation or when positioning in a machine, magnetic tapes shall not be left in a horizontal position.

6.3 Handling access

6.3.1 Staff

Only trained staff shall hold and use master magnetic tape recordings.

6.3.2 Physical contact

Magnetic recording tape shall not be touched by fingers except at the beginning and the end of the tape. When magnetic tape must be touched, hands and fingers shall be washed immediately prior to performing the work and/or dye-free, lint-free gloves shall be worn.

6.3.3 Frequency of access

Master recordings shall be handled and moved as infrequently as possible. Procedures shall be established to provide alternate copies of the recordings when frequent usage is required.

6.4 Use of force

6.4.1 General

Magnetic recording tapes shall be held in ways that minimize stress (e.g. pressure or torque) on the tape and the support structure.

6.4.2 Loading force

Excessive force shall not be used to load a magnetic recording tape into either a container or a machine. Pressure shall only be exerted in the hub area for tapes on reels.

6.4.3 Releasing force

Releasing or putting magnetic recording tapes on any surface shall be done gently, minimizing vibration and impact. Tapes and protective cases should never be thrown or dropped.

6.4.4 Flange compression

When the flanges on a reel are forced closer together, serious deformation or crushing damage to the tape can result. Typical actions that cause flange compression are:

- a) picking up or holding a flanged reel from the outer edge with the fingers on one flange and the thumb on the other flange (unfortunately, this is often seen as the most common and convenient way to hold a reel);
- b) stacking tapes or other objects on top of an unprotected reel;
- c) sudden impact such as dropping a tape or hitting it against the edge of a table;
- d) forced closing of a protective case on a tape when there is other material in the case.

6.5 Tape condition

6.5.1 General

Tapes shall be as secure from damage as possible before handling or transportation.

6.5.2 Open reels

During handling or transport, the outer wrap of tapes on open reels shall be secured by the use of non-destructive hold-down tape or reel guard bands specifically made for this purpose.

6.5.3 Cassettes and cartridges

Many cassettes and cartridges have internal mechanisms that prevent the hubs from turning. Cassettes and cartridges that do not have such mechanisms shall be handled and transported with suitable retainers or in protective cases that are designed to prevent hub movement.

6.5.4 Tape position on hub

Tapes shall be wound to the end before being removed from the machine and before storage. The tape pack shall be as smooth as possible.

6.5.5 Robotic systems

Some robotic systems are designed to wind the tape to special "parking" zones on the tape for threading/unthreading of the tape. But, when a tape is removed from the robotic system, it shall be wound to the end.

6.6 General handling

6.6.1 General

Handling of master tapes shall be done so as not to compromise the ability of future users to gain access to the recording.

6.6.2 Labelling

All tapes and their containers shall be clearly labelled with all information necessary to identify content for the life of the recording. Labels shall not interfere with the use of the tape.

6.6.3 Print-through

Print-through can be accelerated by high winding tension, magnetic fields and heat. Analogue audio tapes shall be stored on the take-up reel (tails out) to minimize the effects of print-through [see print-through (3.32)]. Print-through is reduced by rewinding several times.

6.6.4 Erasure

The record protection feature of all master cassettes shall be activated immediately after they have been recorded (see also 7.4).

Erasure of tape content is a virtually non-recoverable problem. Erasure requires close proximity of a strong magnetic field. The strength of field necessary is seldom found in the environment, and erasure of tape data is almost always the result of human error or intent.

7 Environment

7.1 General

During use and handling, many environmental factors affect the functioning and life expectancy of magnetic recording tape. Among the most critical factors are temperature, humidity, cleanliness and the presence of potential contaminants.

Magnetic tape life is affected by chemical deterioration, including binder hydrolysis, loss of lubricant and binder/base separation. The rate at which these events occur varies depending on the chemical formulation used by the manufacturer and the environmental conditions to which the tape is exposed. Although there have been numerous studies about tape longevity and stability that have produced valuable qualitative information, an accelerated life test that produces meaningful quantitative data does not exist yet. Hence, no method is known which will indicate the specific life expectancy of various brands and formulations of magnetic tape.

The environmental conditions given in this clause shall be followed for tapes intended for extended life. They are also recommended for all handling environments in order to prolong the life of all tapes.

7.2 Temperature and humidity

7.2.1 Environmental condition

Magnetic tape life is influenced directly by temperature and humidity. Master tapes shall be handled at stable temperatures between 18 °C and 25 °C and at stable relative humidities between 15 % and 50 %.

7.2.2 Life expectancy

Life expectancy increases when magnetic tape is stored in a cool, dry environment characterized by stable temperatures and humidity. Time out of the recommended storage environment shall be minimized, so as to maximize tape life. For acceptable storage environments, see ISO 18923.

7.2.3 Water avoidance

A major cause of chemical degradation of magnetic recording tape is the interaction with water, called hydrolysis, either directly or through absorption of moisture from the air. Precautions shall be taken to mitigate possible incursion of water due to condensation, floods, leaks and sprinklers, and to limit excess humidity. Walls and enclosures in use- and handling-areas shall be designed to prevent condensation of moisture on interior surfaces. All use- and handling-areas shall be above basement level where water damage is most prevalent. Floors shall be provided with drains or other means of water removal. Drains shall have systems to prevent liquids or sewage from backing-up into the facility. All work and handling surfaces shall be elevated off the floor.

7.2.4 Fungus

Extended exposure to humidities of approximately 65 % RH will promote fungal growth.

7.3 Air quality

7.3.1 General

Impurities in the air may be harmful to magnetic tape. An expert should be consulted about removal of harmful particles from the air.

7.3.2 Air flow

Positive air pressure in use- and handling-areas shall be maintained relative to adjacent hallways, rooms and facility exteriors to minimize contamination from outside sources.

7.3.3 Cleanroom specifications

Record, playback and inspection usage of magnetic recording tape shall be performed in a cleanroom environment class 100 000 or better as defined in ISO 14644-1 and ISO 14644-2 [i.e. the number of particles larger than 1 μm per cubic foot (0,028 3 m^3) of air shall not exceed 100 000; Class 100 000 is like a dust-free office and requires cleanroom clothing].

7.4 Magnetic fields

7.4.1 General

External magnetic fields are observed most frequently near motors and transformers (e.g. elevators and lifts), but potentially damaging fields can be generated by some headphones, speakers, microphones, magnetic cabinet latches and magnetized tools. Care shall be taken during handling and transportation to avoid placing tapes in close proximity to potential sources of magnetic fields.

7.4.2 Levels

Within use- and handling-areas, the peak intensity of external steady-state (DC) fields shall not exceed 4 kA/meter (50 Oersteds) and the peak intensity of external varying (AC) fields shall not exceed 800 A/meter (10 Oersteds).

7.4.3 Separation distance

Most sources of magnetic fields are localized and the field intensity falls off rapidly with separation (a separation of a few centimetres from the source will usually provide adequate protection).

7.4.4 Print-through

Magnetic fields, heat and high winding tension accelerate print-through (see 6.6.3).

7.5 Light exposure

Magnetic recording tapes and their protective cases can be damaged by exposure to ultraviolet (UV) light. Tapes and protective cases shall not be exposed to direct sunlight. Use-areas should not have outside windows, skylights or other sources of natural lighting. To minimize UV damage, artificial UV sources such as fluorescent lighting shall have appropriate UV filters installed in accordance with the manufacturer's guidelines, and tapes shall be kept in their protective cases except when in active use. To reduce UV damage to protective cases and labels, lights shall be turned off in use- and handling-areas when the areas are not occupied.

7.6 Acclimatization

7.6.1 General

Environments may vary slightly from the general guidelines depending on the specific use, the duration of exposure during specific use, and the practical realities of use in environments where human control of the environment is severely limited. Cooler and drier environments are better for tape longevity; however, at the coldest and driest levels acceptable for long-term storage, some tapes cannot be used immediately in playback mode. Tapes stored in such conditions shall be acclimatized to a different set of environmental conditions for playback to be both safe and successful. Acclimatization is the process of altering temperature and moisture content of magnetic tape so that it can be used at a substantially different temperature and/or humidity level. A compromise between energy input, longevity, comfort of handling, access time and health requirements of operating staff shall be achieved. In tropical climatic zones, a slightly higher temperature for the handling environment (25 °C) may be unavoidable, with the clear understanding that storage and handling environments shall not differ substantially unless acclimatization is properly carried out.

7.6.2 Common problems

Failure to acclimatize tapes can result in pack slippage, creasing during handling, mistracking during playback and moisture condensation. Tapes exposed to temperatures above 25 °C or relative humidities above 50 % shall be acclimatized before playback.

7.6.3 Dimensional changes

Magnetic recording tape will expand and contract when exposed to different levels of temperature and humidity. Depending on the format, tapes recorded at one temperature/humidity level may suffer from mistracking if playback is attempted at a substantially different temperature/humidity level. If the differential between the initial environment and the destination environment is particularly great, it may be necessary to acclimatize gradually or in steps.

7.6.4 Condensation

The most common reason to acclimatize tape is to avoid moisture condensation. This can be avoided by use of a staging room or an enclosure. The tape shall not be removed from the staging environment until it is above the dew point of the use environment.

7.7 Marginal environments

7.7.1 General

To mitigate negative environmental factors, magnetic recording tapes shall not be removed from the buffering effect provided by their protective cases when in packing, shipping or receiving areas. To further buffer tapes from exterior environmental factors, they shall be packed in additional, non-dusting, insulating material for shipment.

7.7.2 Shipping and receiving areas

Temporary fluctuations beyond the accepted temperature and humidity ranges are permissible as long as the environment is returned to recommended levels in less than one hour. Staging or holding areas for shipping and receiving shall not have direct access to the outdoors. Two sets of doors shall be used to minimize the

impact of external temperatures and contaminants. Packing and unpacking shipments produces unavoidable debris substantially in excess of recommended levels. Areas where these activities are performed shall be cleaned on a regular basis to minimize the accumulation of debris.

7.7.3 Field environments

In the field, magnetic recording tapes and protective cases shall be shielded from environmental extremes, including direct exposure to water, dust and sunlight. Tapes shall be kept in their protective cases unless they are being used. When possible, tapes not needed for immediate use shall be kept in an air-conditioned space [e.g. hotel room, office, electronic news gathering (ENG) uplink van]. As recording equipment is an integral part of the field use environment, these precautions shall be applied to the equipment as well as to the tape.

7.7.4 Robotic environments

Robotic recording and playback systems shall be carefully examined to determine that they do not exceed any of the conditions for heat, relative humidity, excessive vibration and movement, dust or dirt, moisture or magnetic fields, as set forth in this document. Robotic storage and retrieval systems shall also comply with ISO 18923.

8 Inspection

8.1 General

A comprehensive plan for the inspection of magnetic tape before use is essential in order to:

- a) prevent damage to the tape itself;
- b) extend tape life;
- c) prevent damage to the machinery on which it is transported or played back.

Periodic inspection during storage is also essential to prevent premature loss of materials. See AES22:1997 and ISO 18923 for information regarding inspection related to storage of magnetic tape. Tape shall be physically inspected before every major change in status; e.g. before shipment, before playback and before placement in storage.

8.2 Seven-step physical inspection

A minimum seven-step physical inspection is recommended. While this examination does not identify all the problems that can occur, if tape fails any of these inspection criteria, it is endangered and needs attention.

Attempts to play back such tapes before treatment place them and the selected machinery at risk. The following inspection procedure shall be performed in the order listed.

- 1) The physical container shall be examined for any damage that compromises the structural integrity of the container itself. Breakage is a strong indication of improper handling. If the container, reel or cassette is damaged, the tape inside is also likely to have suffered damage or contamination.
- 2) The container and the edges of the tape shall be inspected for patterned black, brown or mustard-coloured contamination and for fuzzy or thread-like growths that indicate the presence of fungus. Fungus can grow on tape and containers after exposure to high humidity. Tapes with fungus shall be isolated and treated by professionals as soon as possible. Tape with fungus can present a health hazard: if fungus is suspected, inspection shall not be continued.
- 3) The tape shall be inspected for odour as soon as the container is opened. If a musty odour is detected, the inspection shall be terminated as this may indicate the presence of fungus. Hydrolytic breakdown of polyurethane binder creates esters that have distinctive odours but dissipate quickly. The most common odours can be characterized as "waxy", "dirty socks", or "astringent/pungent" depending on the binder. Some early tapes using an acetate base will also give off an odour of "vinegar" if the base is beginning to decay. Tapes with binder hydrolysis are in the process of self-destruction and can stick in the machine during playback, causing additional damage.

- 4) With a light source above and slightly behind the inspector, the tape shall be tilted edge-on at approximately a 45 degree angle. The tape pack shall be inspected for popped strands, stepped pack, flange pack, edge damage, cinching and gaps in the pack as shown in Figures 1 and 4. These terms refer to irregularities in the way the tape is wound onto the hub and are indications of improper handling or storage, or a badly adjusted machine. Spoking shows up as a pattern radiating out from the hub and is the result of improper tension. Popped strands and stepped pack refer to individual or groups of tape wraps that stick up from the edge of the pack. Flange pack occurs when the whole tape pack rests against the flange. Torn, worn or folded tape often shows up as areas of greater reflection in the pack. Gaps in the tape pack are caused by tape being loose on the hub. Often this indicates an area where the tape is folded back over on itself [see cinching (3.9)].

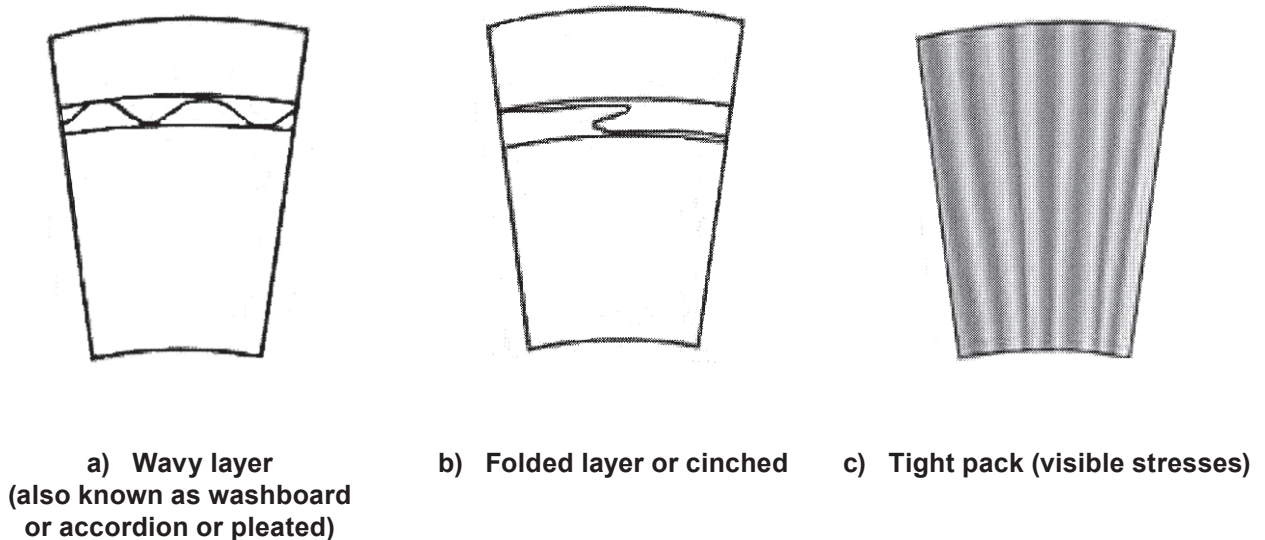

Figure 4 — Three examples of tape damage

- 5) The tape edge and the reel/cassette/cartridge shall be inspected for particulate contamination and for signs of staining that may indicate liquid contamination. Any visible contamination is an indication of poor storage or handling. Particulate contamination can block the signal during playback and can scratch both the tape and the playback heads. Liquid contamination may accelerate tape decay and often results in tape wraps sticking together.
- 6) The tape edge shall be examined for white powder or crystalline residue and the interior of the container shall be examined for black/brown flakes. These symptoms are caused by a variety of conditions and indicate that the tape has started to degrade.
- 7) With open reel tapes, a loose vertical strand shall be inspected for surface contamination, physical distortion and binder/base adhesion failure. Physical distortion caused by improper tension often appears as wavy or “scalloped” edges. Binder/base failure is identified by sections of the tape that appear in a different colour where material has separated.

9 Cleaning and maintenance

9.1 General

Magnetic tapes can be damaged physically during usage if both the tape and the machinery are not clean and well maintained. Debris on the tape or tape path components will cause scratching, scoring or abrasion of the tape and machine read/write heads. Misaligned or poorly functioning machinery will cause tape damage.

9.2 Tape cleaning indicators

If the physical condition of the tape is unknown, or the tape is known to be contaminated, tape cleaning shall be performed to remove foreign debris and decay residues from both surfaces of the tape. Cleaning may also be performed to evaluate a tape for the presence of these contaminants. Minute debris between the tape surface and the head can cause loss of signal. Large particles (see Figure 2) of foreign debris and heavy residues from tape deterioration can cause permanent damage to the tape or to playback machinery, or alter playback characteristics. The type of defect depends on the format and the hardness of the cluster of particles.

9.3 Tape cleaning frequency

Before use, tapes should be inspected. If, during inspection, there is any evidence of debris on the tape, or in the container or shell, appropriate cleaning shall be done. If the tape transport must be stopped during playback due to head clogs, sticking or skidding, cleaning shall be done prior to resuming playback. If the tape did not originate in-house or the physical condition has not been recently confirmed as acceptable, the tape shall be cleaned before placement in extended-term storage conditions. Regular and frequent cleaning is unnecessary unless addressing a specific problem. For information on cleaning in relation to storage of magnetic tapes, see ISO 18923.

9.4 Debris removal from tape

9.4.1 Cleaning procedure

Tape cleaning is a precise and difficult process and shall not be done without proper training and equipment. Cleaning of dry-particulate debris, such as dirt, dust or shedding binder, shall be done with long-fibre, non-dusting, non-abrasive tissues. It is essential that debris removed during the cleaning process is not redeposited back onto the tape. Removal can be achieved, for example, by a moving tissue or by a vacuum. Both surfaces of the tape shall be wiped. For contaminants other than dry-particulate debris, a professional restoration expert shall be used.

9.4.2 Tape burnishing

Razor blades, playback heads and abrasive materials shall not be used to clean tapes. Burnishing of the tape surface may be used to enhance the cleaning process. Only burnishing mechanisms designed specifically for cleaning magnetic tape shall be used.

9.4.3 Tape cleaning equipment

All equipment used for cleaning tape shall have a tape path that is fully visible and accessible to the operator during tape transport. Any surface that comes into contact with the tape during cleaning shall be accessible and shall be cleaned before each tape is placed on the machine. Tape transports shall guide the tape by the edges and shall not expose the tape to surfaces, tension or stress that cause deformation.

9.5 Adhesive contaminants on tape

9.5.1 Adhesive tapes

Some contaminants exhibit characteristics that cause adjacent tape wraps to adhere. The two most common are:

- a) the oligomer residue from hydrolytic chemical decay of the tape binder;
- b) residues left on the tape from exposure to liquids, splices and other foreign contaminants.

9.5.2 Tape adhesion

If tape wraps are adhering, tissue wiping or burnishing on a mechanical transport shall not be done until tapes have been treated to reduce tape-to-tape adhesion. Treatment is highly dependent on the cause of the problem. Effective treatment requires exposure to environments, substances and handling that will seriously damage tape if applied improperly. Treatment shall be performed only after positive identification of the specific

problem or problems involved. Only treatments with a known history of success and with minimum negative side effects shall be used on recorded tapes.

9.6 Biological contaminants on tape

The most common biological contaminant of tape is fungus. Fungus shall be considered toxic and treated with great care. If fungus smears when rubbed, it is active. A tape with active fungus shall not be cleaned. The tape shall be stored in a dry environment until the fungus is dormant. Dormant fungus appears as a dry powder. Surface cleaning of fungus does not kill it. A professional tape restoration expert shall be consulted. Unprotected personnel shall not handle tapes contaminated with fungus. Both the environment and the equipment used when cleaning off fungus shall be decontaminated after cleaning is complete. Cleaning machinery shall be decontaminated after each tape.

9.7 Record/playback machine maintenance

The most common type of usage damage is caused by running tape on a machine that is not properly maintained. If full-time tape recorder maintenance personnel are not available, a highly-qualified service company shall be used to conduct maintenance procedures on a regular basis.

9.8 Transports for master tapes

All equipment used for recording or playing back master tapes shall be of the highest possible quality and of the most appropriate technology produced for the tape format. All tape transports shall be properly maintained and continually inspected during the transfer process.

9.9 Manufacturers' recommendations

Tape recorders shall be regularly cleaned and maintained according to manufacturers' recommendations.

9.10 Cleaning cassettes

If cleaning cassettes are recommended by the manufacturer of the machine, the directions that come with the cleaning cassette shall be followed. Cleaning cassettes will not remove tape path debris that is encrusted/embedded in tape path components. This debris shall be removed by hand.

9.11 Hand cleaning

Encrusted/embedded debris shall be removed by using a cotton swab and a chemical listed in the tape recorder maintenance manual. When cleaning a tape recorder by hand, the procedure in the tape recorder maintenance manual shall be followed. Cleaning a tape recorder by hand can damage precision components (e.g. rotating heads). Hand cleaning shall not be attempted unless performed by a skilled person knowledgeable about the potential problems.

10 Transportation

10.1 General

Unless specifically cited as a variant, the principles and procedures cited throughout this International Standard shall be equally applicable to tapes while in transport both within and outside the collection.

10.2 Tape preparation before transport

10.2.1 Security tape wrap

During handling or transport, the outer wrap of tapes on open reels shall be secured by the use of non-destructive hold-down tape or reel guard bands specifically made for this purpose. Many cassettes and

cartridges have internal mechanisms that prevent the hubs from turning. Cassettes and cartridges that do not have such mechanisms shall be handled and transported with suitable retainers or in protective cases designed to prevent hub movement.

10.2.2 Protective cases

Tapes shall be placed in protective cases before transport both within and outside the facility.

10.2.3 Flangeless hubs

Special care shall be taken in handling tapes stored on hubs without flanges (pancakes).

10.2.4 Orientation

Tapes shall be placed in their packing container so that they stand vertically, and packed in such a manner as to reduce the danger of vibration and impact.

10.2.5 Cartons

Cartons and containers used for packing or transporting magnetic tapes shall be built solidly to protect the tape. The underside of each carton shall be inspected to ensure that it is intact and capable of bearing the load.

10.3 Transport methods

10.3.1 By hand

Tapes shall not be thrown or dropped. Impact and vibration shall be avoided.

10.3.2 Carts

Hand carts (trolleys) and hand trucks used for movement of tapes shall be designed to ensure that the tapes do not slip or fall off, and they shall keep the tapes in a vertical position. The carts shall be built solidly to accommodate the maximum anticipated weight when fully loaded. They shall have free-moving wheels of an adequate size and design to ensure that they move smoothly and evenly over floor coverings on level or inclined floors and ramps, including door jambs and floor expansion joints.

10.3.3 Conveyor belts

Conveyor belt systems that subject tape to vibration or a harmful magnetic field shall not be used. See 10.5.3.

10.3.4 Freight

Shipping and transport of tapes shall be accomplished by the fastest and safest overnight or two-day service with insistence on a signed return receipt.

10.3.5 Shipping containers

Shipping containers shall be resistant to water and dust and shall be sealed to ensure that contaminants do not get into the package during transit. Containers shall be built solidly to accommodate heavy tapes. The tape shall be packed with sufficient shock protection (e.g. bubble-pack on all six sides). The bottom of the carton should have two layers of bubble pack or padding. Tapes shall be vertical and packed tightly in containers. Fibre-filled packing material shall not be used. When shipping tapes in a high moisture climate, the tapes shall be sealed in a plastic bag with desiccant.

10.4 General exposure

10.4.1 Time out of storage

Tapes shall be out of their storage area for the minimum time possible. At no time shall they, or the containers/trucks in which they are being moved, be left unattended in open areas. This minimizes the deterioration of the tape and reduces the possibility of theft and damage.

10.4.2 Restricted access

Tapes considered to have permanent value (e.g. master tapes, unique or original recordings) shall not be loaned or shipped without making sure that all criteria mentioned in this International Standard are met by both the shipper and the recipient. As a rule, duplicate or back-up tapes should be shipped in the place of master tapes.

10.5 External fields and security scanning of material

10.5.1 Shielding

During shipment, tapes might be exposed to external energy fields. Tapes shall be shielded from fields that can interfere with future access to the recorded material.

10.5.2 X-rays

Tapes and recorded information are not damaged by properly functioning X-ray equipment.

10.5.3 Electrically generated magnetic fields

A potential problem with airport and other conveyor belt systems is that the electric motor driving the belt may be located immediately under the belt. If this is the case, the magnetic field of the motor may affect any magnetic tape placed on the conveyor belt. To minimize the risk of erasure from magnetic fields, tapes shall be packed with at least 25 mm of space on all sides.

10.5.4 Magnetic security wands

Tapes shall not be exposed to magnetometers such as hand-held security wands. The strong magnetic fields generated by these devices will damage the recording on the magnetic media.

10.5.5 Biological irradiation

Tapes shall not be exposed to high-power biological decontamination scanners. High levels of radiation can produce sufficient heat to melt or deform tapes or their plastic containers.

11 Disasters

11.1 General

Magnetic tapes are highly susceptible to damage in environmental disasters. The three most common results are physical deformation, chemical decay and surface contamination. Short-term exposure to most disaster situations causes no detectable alteration of the recorded signal except in some situations where there is direct contact with, or close proximity to, electro-magnetic fields. The notable exceptions are the increase in print-through on analogue audio tape that is exposed to high temperatures and the possible degradation of metal particle tape and metal evaporated tape by contact with water.

The majority of disaster losses are due to alterations in the physical characteristics of the tapes. These alterations result in an inability to run the tapes properly on a transport and/or accurately read the recorded signal. Many of these physical alterations are extremely time-sensitive. Therefore, problems should be corrected as soon as

possible after the disaster and before attempting to play back tapes. Otherwise, permanent damage can occur that is more severe than the immediate effects of the disaster.

11.2 Water

11.2.1 General

The most common type of disaster is exposure to water. Tape is at risk of exposure to water due to the tremendous variety of sources from which the contamination can originate. Water exposure can result from many sources such as roof leaks, flooding, broken pipes, malfunctioning bathroom fixtures, municipal sewer problems, fire sprinkler systems and spilled drinks.

11.2.2 Effects of water

Exposure to water and various other liquids can seriously weaken the structural integrity of magnetic tape and can alter the frictional coefficient of the tape surface. If tapes are wet or retain a high level of moisture content, exposure to standard stresses and tensions encountered during playback frequently result in permanent deformation. If wet tapes dry unevenly, tape deformation can occur. During drying, chemical impurities in the liquid may concentrate and accelerate destructive reactions with the tape. Wet tape in contact with other surfaces (guide posts in the cassette shells) may adhere to those surfaces when it dries.

11.2.3 Effects of moisture

Some tapes in close proximity to standing water can absorb sufficient moisture to increase hydrolytic breakdown of the binder. Moisture can also promote fungus (mould and mildew) growth.

11.3 Fire

Another common disaster that affects magnetic tape involves fire. In fire scenarios, tapes are exposed to heat, smoke, water, fire suppression chemicals and debris. Each of these contaminants has a different effect on the tape.

If exposed to sufficient heat, tape will melt or burn, but the most frequent damage during a fire is caused by smoke. Smoke will affect most tapes in the general vicinity of a fire, and leaves an oily film on the tape surface which interferes with signal retrieval. Fire also produces particulate debris that may be deposited on the tape.

11.4 Dry debris

Unless a disaster results in fire or flooding, the primary concerns are impact from falling and exposure of the tape to dry particulate debris. Most dry debris will not interact chemically with magnetic tape. Debris that adheres to the tape may interfere with signal retrieval during playback. Debris that is wound into the tape pack can scratch or otherwise deform the tape surface.

11.5 Disaster response

11.5.1 Problem of delay

Most tapes exposed to disasters are not destroyed by the initial exposure. Most damage results from improper handling after a disaster or from delay in remedial work. While tapes are fairly resistant to chemical decay over short periods of time, they may be contaminated with chemicals that will interact with the tape during extended exposure. The steps indicated in 11.5.2 to 11.5.6 shall be taken as soon as possible to minimize loss. If possible, both the handling and the decontamination shall be performed by specialists with a record of success in salvaging tapes from disasters. It is recommended that a professional tape restoration expert be consulted.

11.5.2 Initial handling

As soon as a disaster site has been secured against possible injury to personnel, tapes shall be removed from the site to avoid further contamination and damage. They shall be moved carefully, keeping the tape in a vertical

orientation. Where liquid is present, changes in orientation which spread contamination shall be avoided. Tapes shall be cushioned against shock and insulated against sudden changes in temperature. They shall not be spooled or played back before decontamination. Tapes shall be decontaminated as soon as possible.

11.5.3 Temporary storage

Tapes shall not be returned to long-term storage before decontamination. Temporary storage shall be in a cool environment. Tapes shall be acclimatized before placing them on cleaning or playback machinery. They shall be stored in the proper vertical orientation so that they are supported by the hub.

11.5.4 Damage mitigation/wet tapes

Wet tapes are particularly vulnerable to damage. Biological and chemical deterioration can occur within 24 h. Tapes shall be decontaminated before they are allowed to dry. If water is used to rinse some chemical contaminants from the tape, only cold distilled water shall be used. All wet paper and cardboard, excluding labels, shall be removed from the vicinity of the tape as quickly as possible to reduce water retention and potential fungal growth. If fungal growth is detected, tapes shall be treated only by trained personnel.

11.5.5 Damage mitigation/dry tapes

Dry particulate debris can become airborne and spread easily to its surrounding environment. Contaminated tapes shall be isolated until decontamination is completed. Liquids shall not be used to remove dry particulate debris.

11.5.6 Decontamination and disassembly

Proper decontamination may require that tapes be removed from their hubs. Hubs, cassettes, cartridges and reels may need to be disassembled and decontaminated or replaced. Tape is extremely vulnerable while off the hub. Disassembly and decontamination shall be performed only by personnel with proper training.

12 Staff training

12.1 Purpose

Only trained personnel shall handle magnetic tape intended for long-term usage. The preservation and effective use of information contained on magnetic recording tape is enhanced by a regular staff training programme.

The purpose of such a programme shall be to achieve the following goals:

- a high level of technical competence among staff;
- familiarity with the functional characteristics of equipment;
- awareness of required safety procedures including fire control and chemical, biological and electrical hazard avoidance;
- knowledge of policies and procedures governing work.

12.2 Training paths

An effective training programme shall consist of at least two paths – one for new staff and one for continuing staff. Whether staff are paid or volunteers, they shall receive regular training. The formal training programme shall be supplemented by day-to-day supervision. Each organization shall develop a programme fitted to its individual circumstances and needs. The training programme shall be updated regularly as equipment, procedures and needs change.

12.3 Schedule for training

New employees shall commence training within one month of commencing employment. Continuing employees shall receive updating training sessions at least once each year.

12.4 Update of training

Staff training programmes shall be revised and updated whenever major changes occur (e.g. staff changes, major equipment changes, significant redirection of mission and services).

12.5 Content of training

Staff training programmes shall include the following components:

- a) mission, goals and objectives of the organization;
- b) position descriptions stating the roles and responsibilities of each staff member;
- c) published standards and a bibliography of other information relevant to the work of the repository;
- d) guidelines governing access to the materials;
- e) maintenance schedules and procedures for equipment used in the facility;
- f) cataloguing, labelling and shelf arrangement;
- g) physical facilities issues and concerns (e.g. location of fire alarms and emergency shut-off valves);
- h) occupational health and safety;
- i) instruction on the handling of magnetic tape;
- j) actions to take if a disaster occurs.

13 Minimum handling requirements checklist

13.1 General

This checklist is not a complete guideline or summary for tape care and handling. It contains only those items that experience and testing show will have an immediate or severe effect on magnetic tape. Failure to adhere to the items on this list may cause premature loss or deterioration of magnetic tapes and shall be considered misuse of the medium. These are minimum handling requirements that summarize good practice. An explanation and expansion of these and other items can be found elsewhere in the text of this International Standard.

13.2 Do's

Familiarize yourself with proper techniques for the care and handling of magnetic tape:

- 1) handle tapes gently;
- 2) keep tapes in protective cases when not in use;
- 3) keep tapes vertical when not in use;
- 4) protect both tapes and machinery from dust and debris;
- 5) keep tapes in a stable environment;
- 6) store tapes in a cool and dry place; see ISO 18923;
- 7) use only new tape when recording a tape for long-term storage;

- 8) acclimatize tapes before use if they are hot or cold;
- 9) inspect tapes for damage or contamination before use;
- 10) clean tapes before playback if they show any evidence of dirt or contamination;
- 11) learn and use correct procedures for operating equipment;
- 12) make sure machine alignment is correct before use;
- 13) ensure that the tape is properly seated in the machine before use;
- 14) activate the record protection feature of all master cassettes immediately after they have been recorded;
- 15) wind tape at low speed (library wind) entirely onto one reel after use;
- 16) leave analogue audio tapes on the take-up reel after use (tails out);
- 17) secure tape ends on open reel tapes after use;
- 18) package tapes adequately for protection before shipment or transport;
- 19) seek experienced help as soon as possible in the case of a disaster.

13.3 Do not's

- 1) do not expose tapes to temperature extremes;
- 2) do not store tapes in an area subject to dampness or possible pipe leaks (e.g. basements);
- 3) do not expose tapes to UV radiation, including the sun, for extended periods;
- 4) do not expose tapes to food or beverages;
- 5) do not drop or throw tapes;
- 6) do not stack or place objects on top of unprotected tapes;
- 7) do not touch tape surfaces with bare hands;
- 8) do not splice any portion of a video tape;
- 9) do not put pressure on reel flanges;
- 10) do not force tapes into cases or machines;
- 11) do not play or spool tapes that are dirty, contaminated or wet;
- 12) do not play or spool tapes on a dirty, misaligned or malfunctioning machine;
- 13) do not place tapes on or near sources of magnetic fields;
- 14) do not expose tapes to high-power biological decontamination scanners; high levels of radiation can produce sufficient heat to melt or deform tapes or their plastic containers;
- 15) do not attempt to clean tapes contaminated with adhesives, fungus or unknown substances unless you have the necessary experience or training.

Bibliography

- [1] BERTRAM, H.N. and CUDDIHY, E.F. *Kinetics of the Humid Aging of Magnetic Recording Tape*, IEEE Transactions on Magnetics, 1982, MAG-18
- [2] MEE, C.D. and DANIEL, E.D. *Magnetic Recording Technology*, 1995, McGraw-Hill
- [3] SMITH, L.E. *et al. Prediction of the Long-term Stability of Polyester-based Recording Media*, in National Bureau of Standards, Report No: NBSIR 86-3474, 1986
- [4] VAN BOGART, J.W.C. *Magnetic Tape Storage and Handling: A Guide for Libraries and Archives*, J. National Media Laboratory, June 1995, The Commission on Preservation and Access, 1 400 16th Street, Suite 740, Washington, D.C. 20036-1000
- [5] SMPTE RP-103: *Care, Storage, Operation, Handling and Shipping of Video Tape for Television*
- [6] SMPTE RP-190: *Care and Preservation of Audio Magnetic Recordings*
- [7] AES22:1997, *AES recommended practice for audio preservation and restoration — Storage and handling — Storage of polyester-base magnetic tape*

British Standards Institution (BSI)

BSI is the national body responsible for preparing British Standards and other standards-related publications, information and services.

BSI is incorporated by Royal Charter. British Standards and other standardization products are published by BSI Standards Limited.

About us

We bring together business, industry, government, consumers, innovators and others to shape their combined experience and expertise into standards-based solutions.

The knowledge embodied in our standards has been carefully assembled in a dependable format and refined through our open consultation process. Organizations of all sizes and across all sectors choose standards to help them achieve their goals.

Information on standards

We can provide you with the knowledge that your organization needs to succeed. Find out more about British Standards by visiting our website at bsigroup.com/standards or contacting our Customer Services team or Knowledge Centre.

Buying standards

You can buy and download PDF versions of BSI publications, including British and adopted European and international standards, through our website at bsigroup.com/shop, where hard copies can also be purchased.

If you need international and foreign standards from other Standards Development Organizations, hard copies can be ordered from our Customer Services team.

Subscriptions

Our range of subscription services are designed to make using standards easier for you. For further information on our subscription products go to bsigroup.com/subscriptions.

With **British Standards Online (BSOL)** you'll have instant access to over 55,000 British and adopted European and international standards from your desktop. It's available 24/7 and is refreshed daily so you'll always be up to date.

You can keep in touch with standards developments and receive substantial discounts on the purchase price of standards, both in single copy and subscription format, by becoming a **BSI Subscribing Member**.

PLUS is an updating service exclusive to BSI Subscribing Members. You will automatically receive the latest hard copy of your standards when they're revised or replaced.

To find out more about becoming a BSI Subscribing Member and the benefits of membership, please visit bsigroup.com/shop.

With a **Multi-User Network Licence (MUNL)** you are able to host standards publications on your intranet. Licences can cover as few or as many users as you wish. With updates supplied as soon as they're available, you can be sure your documentation is current. For further information, email bsmusales@bsigroup.com.

BSI Group Headquarters

389 Chiswick High Road London W4 4AL UK

Revisions

Our British Standards and other publications are updated by amendment or revision.

We continually improve the quality of our products and services to benefit your business. If you find an inaccuracy or ambiguity within a British Standard or other BSI publication please inform the Knowledge Centre.

Copyright

All the data, software and documentation set out in all British Standards and other BSI publications are the property of and copyrighted by BSI, or some person or entity that owns copyright in the information used (such as the international standardization bodies) and has formally licensed such information to BSI for commercial publication and use. Except as permitted under the Copyright, Designs and Patents Act 1988 no extract may be reproduced, stored in a retrieval system or transmitted in any form or by any means – electronic, photocopying, recording or otherwise – without prior written permission from BSI. Details and advice can be obtained from the Copyright & Licensing Department.

Useful Contacts:

Customer Services

Tel: +44 845 086 9001

Email (orders): orders@bsigroup.com

Email (enquiries): cservices@bsigroup.com

Subscriptions

Tel: +44 845 086 9001

Email: subscriptions@bsigroup.com

Knowledge Centre

Tel: +44 20 8996 7004

Email: knowledgecentre@bsigroup.com

Copyright & Licensing

Tel: +44 20 8996 7070

Email: copyright@bsigroup.com



...making excellence a habit.™